

12 INPUT, 12 OUTPUT VALVE CONTROLLER, Multi-functional

7 Universal Signal and 5 Digital Inputs

8-2.5A Proportional and 4-3A On/Off Outputs

1 +5V, 100 mA Reference Voltage

CAN (SAE J1939)

with Electronic Assistant

P/N: AX020400A

Features:

- 6 Universal Signal Inputs are user configurable as:
 - 0-5V, 0-10V, 4-20mA or 0-20mA
 - 20Ω to 250 kΩ Resistive
 - 1 Hz to 10 kHz PWM
 - Digital
 - Three of the inputs can be configured as a pulse counter.
- 1 Signal Input is user configurable as:
 - 0-5V, 0-10V, 4-20mA or 0-20mA
 - 1 Hz to 10 kHz PWM
 - Digital
- 5 PWM/Digital Inputs are user configurable as:
 - 1 Hz to 10 kHz PWM
 - Active High/Active Low Digital
 - Pulse Counter
- 8 Outputs (0...2.5A) drive proportional poppet or spool or On/Off hydraulic valves and are user selectable as:
 - Proportional Current
 - Hotshot Digital
 - PWM Duty Cycle
 - Proportional Voltage
 - On/Off Digital
 - Three of the inputs can be configured as a pulse counter.
- 4 Outputs (3A) to drive ON/OFF hydraulic valves
- 1 SAE J1939 CAN bus port with auto-baud-rate detection
- 12V or 24Vdc nominal power
- Surge, transient, reverse polarity, overvoltage, undervoltage and short circuit protections
- -40 to +85 °C operating temperature
- Designed for EMC compliance, CE marking
- 48 pin TE Deutsch enclosure and connectors
- IP67 rating
- Vibration compliant
- Configurable with Electronic Assistant



Applications:

- Oil and Gas Equipment Automation
- Off-highway Machine Automation
- Agricultural Equipment

Ordering Part Numbers:

Controller, SAE J1939, auto-baud-rate detect, Extended Functionality: **AX020400A**

Controller, SAE J1939, auto-baud-rate detect: **AX020410A** (*Refer to datasheet TDAX020410A.*)

Controller, CANopen: **AX020411A** (*Refer to datasheet TDAX020411A.*)

Accessories:

Mating Plug Kit: **AX070123**

Electronic Assistant Configuration KIT: **AX070502** or **AX070505K**

Description: The valve controller provides precise, repeatable control of 8 proportional or on/off solenoids plus 4 on/off solenoids. It is networked on a SAE J1939 bus. Up to 7 signal inputs and 5 digital inputs are accepted for interface to a PLC, Engine Control Module, switches, command potentiometers or sensors. It operates with 12Vdc or 24Vdc power. The controller has altogether twelve inputs, which are divided into Universal and Digital Inputs. Universal Inputs can be configured to measure voltage, current or digital signal and Digital Inputs can be configured to measure digital signals. In addition, Universal Inputs 1 to 6 can be configured to measure resistance. Frequency, signal pulse width and pulse count can be measured with Universal Inputs 1, 3, 5, 7 and Digital Inputs 1, 3, 5. Designed for rugged machine applications, it features an IP67 rating, CE marking and is suitable for high vibration installations.

Controller settings are user configurable to suit many applications. Configuration is via a *Windows*-based Electronic Assistant configuration tool and an USB-CAN converter. From the control logic perspective, the AX020400 consists of a set of internal functional blocks, which can be individually configured. Using the input function block, each input can be configured to measure the input value and send the data to a SAE J1939 network. With the output function block, any output on the controller can be configured to use any of the onboard inputs as either a control signal or an enable signal, instead of taking the control information from the CAN bus. The PID Control Function Block is associated with the proportional output type. The Lookup Table Function Block is used to give output response up to 10 slopes per input. If more than 10 slopes are needed, then the Programmable Logic Function Block is used to combine up to 3 tables to generate up to 30 slopes. The Math Function Blocks allow the user to define basic algorithms. The DTC React Function Block allows for a received DTC from another device on the CAN network to disable an output or act as an input to a function block. Diagnostics messages are provided over the CAN network for the status of inputs or outputs and are configurable via the Diagnostic Function Block.

Block Diagram:

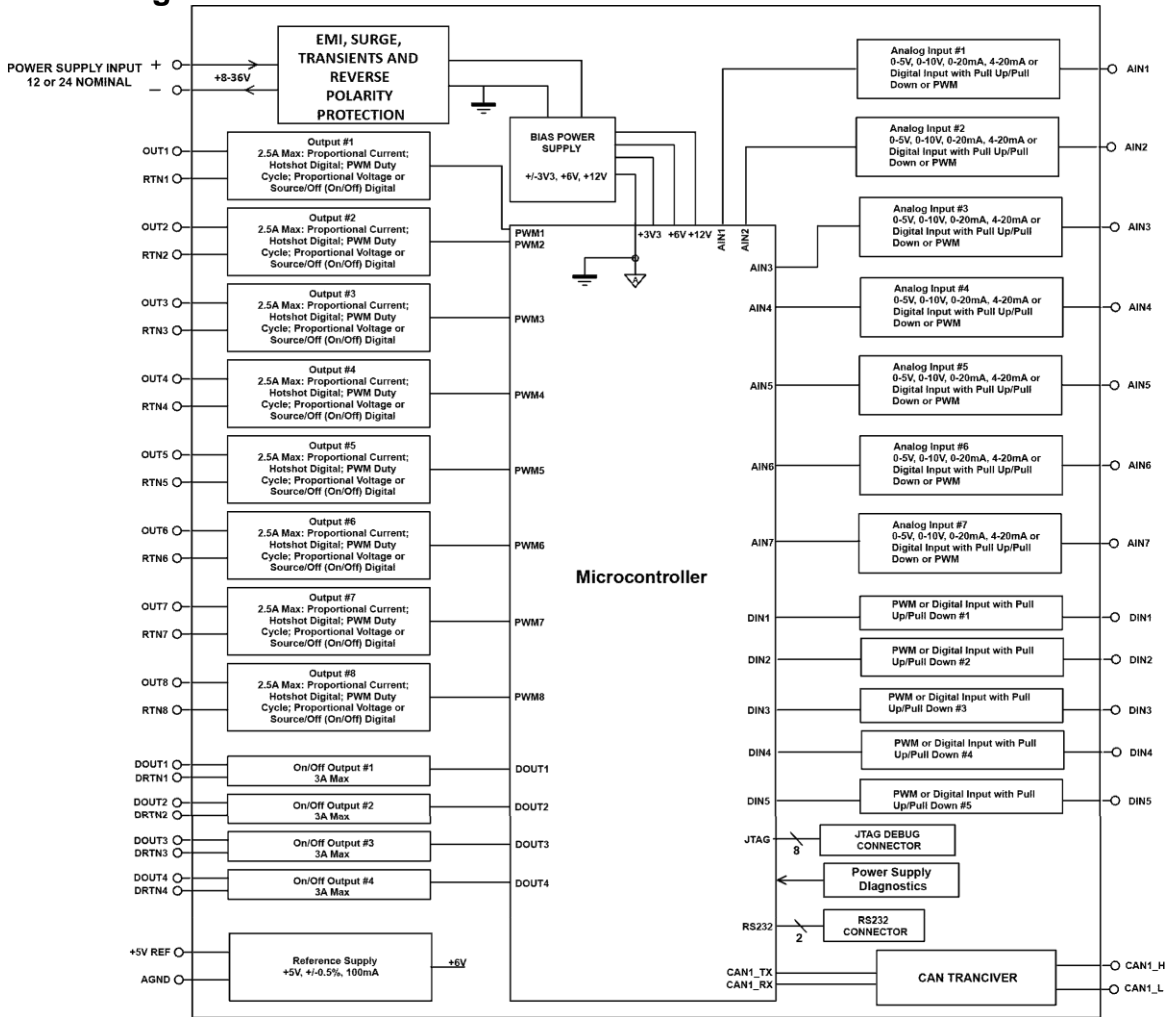

Technical Specifications:

Input Specifications

Power Supply Input	12 or 24Vdc nominal (8...36 Vdc power supply range) NB. The maximum total current draw permitted on the power supply input pins is 15 Amps @ 24Vdc, at one time.
Reverse Polarity Protection	Suitable for engine cranking and load dump
Surge and Transient Protection	Provided
Under-voltage Protection	Provided (hardware shutdown)
Overtoltage Protection	Provided (hardware shutdown)
All Inputs	Up to 12 inputs are selectable by the user from the following. <ul style="list-style-type: none"> • 7 Universal Signal Inputs • 5 PWM/Digital Inputs All inputs, except for frequency and counter, are sampled every 10ms.

<p>Universal Signal Input Configuration</p>	<p>Inputs 1 through 6 are configurable as the following.</p> <ul style="list-style-type: none"> • Disable Input • 12-bit Analog to Digital (0...5Vdc, 0...10Vdc) (4...20mA or 0...20mA, Current sense resistor 124Ω) (20Ω to 250 kΩ Resistive) • Digital input (Active High to Vps or Active Low to GND, Amplitude 3.3V to +Vps, Configurable pull up or pull down resistor) <p>In addition, inputs 1, 3 and 5 are configurable as the following.</p> <ul style="list-style-type: none"> • PWM Signal (Frequency: 1-10,000 Hz, 0-100% D.C., 1MΩ impedance) • Pulse Counter input 																																												
<p>Signal Input 7 Configuration</p>	<p>Input 7 is configurable as the following.</p> <ul style="list-style-type: none"> • Disable Input (No CAN messages associated with that channel are sent.) • 12-bit Analog to Digital (0...5Vdc, 0...10Vdc) (4...20mA or 0...20mA, Current sense resistor 124Ω) • PWM Signal (Frequency: 1-10,000 Hz, 0-100% D.C., 1MΩ impedance) • Pulse Counter • Digital input (Active High to Vps or Active Low to GND, Amplitude 3.3V to +Vps, Configurable pull up or pull down resistor) 																																												
<p>PWM/Digital Input Configuration</p>	<p>PWM/Digital Inputs 1 through 5 are configurable as the following.</p> <ul style="list-style-type: none"> • Disable input • Digital input (Active High to Vps or Active Low to GND, Amplitude 3.3V to +Vps, Configurable pull up or pull down resistor) <p>In addition, inputs 1, 3 and 5 are configurable as the following.</p> <ul style="list-style-type: none"> • PWM Signal (Frequency: 1-10,000 Hz, 0-100% D.C., 1MΩ impedance) • Pulse Counter input 																																												
<p>Minimum and Maximum Ratings</p>	<table border="1"> <thead> <tr> <th colspan="4">Table 1.0. Absolute Maximum and Minimum Ratings</th> </tr> <tr> <th>Characteristic</th> <th>Min</th> <th>Max</th> <th>Units</th> </tr> </thead> <tbody> <tr> <td>Power Supply</td> <td>8</td> <td>36</td> <td>V dc</td> </tr> <tr> <td>Voltage Input</td> <td>0</td> <td>36</td> <td>V dc</td> </tr> <tr> <td>Current Input</td> <td>0</td> <td>21</td> <td>mA</td> </tr> <tr> <td>Current Input – Voltage Level</td> <td>0</td> <td>36</td> <td>Vdc</td> </tr> <tr> <td>Digital Type Input – Voltage Level</td> <td>0</td> <td>36</td> <td>Vdc</td> </tr> <tr> <td>PWM Duty Cycle</td> <td>0</td> <td>100</td> <td>%</td> </tr> <tr> <td>PWM Frequency</td> <td>50</td> <td>10 000</td> <td>Hz</td> </tr> <tr> <td>PWM Voltage pk - pk</td> <td>0</td> <td>36</td> <td>V dc</td> </tr> <tr> <td>RPM Frequency</td> <td>50</td> <td>10 000</td> <td>Hz</td> </tr> </tbody> </table>	Table 1.0. Absolute Maximum and Minimum Ratings				Characteristic	Min	Max	Units	Power Supply	8	36	V dc	Voltage Input	0	36	V dc	Current Input	0	21	mA	Current Input – Voltage Level	0	36	Vdc	Digital Type Input – Voltage Level	0	36	Vdc	PWM Duty Cycle	0	100	%	PWM Frequency	50	10 000	Hz	PWM Voltage pk - pk	0	36	V dc	RPM Frequency	50	10 000	Hz
Table 1.0. Absolute Maximum and Minimum Ratings																																													
Characteristic	Min	Max	Units																																										
Power Supply	8	36	V dc																																										
Voltage Input	0	36	V dc																																										
Current Input	0	21	mA																																										
Current Input – Voltage Level	0	36	Vdc																																										
Digital Type Input – Voltage Level	0	36	Vdc																																										
PWM Duty Cycle	0	100	%																																										
PWM Frequency	50	10 000	Hz																																										
PWM Voltage pk - pk	0	36	V dc																																										
RPM Frequency	50	10 000	Hz																																										
<p>Input Accuracy and Resolution</p>	<table border="1"> <thead> <tr> <th colspan="3">Table 2.0. Input Accuracy</th> </tr> <tr> <th>Input Type</th> <th>Accuracy</th> <th>Resolution</th> </tr> </thead> <tbody> <tr> <td>Voltage</td> <td>+/- 1%</td> <td>1 [mV]</td> </tr> <tr> <td>Current</td> <td>+/- 1%</td> <td>1 [uA]</td> </tr> <tr> <td>Resistive</td> <td>+/- 1%</td> <td>1 [Ω]</td> </tr> <tr> <td>PWM</td> <td>+/- 1% (<5kHz) +/- 2% (>5kHz)</td> <td>0.01 [%]</td> </tr> </tbody> </table>	Table 2.0. Input Accuracy			Input Type	Accuracy	Resolution	Voltage	+/- 1%	1 [mV]	Current	+/- 1%	1 [uA]	Resistive	+/- 1%	1 [Ω]	PWM	+/- 1% (<5kHz) +/- 2% (>5kHz)	0.01 [%]																										
Table 2.0. Input Accuracy																																													
Input Type	Accuracy	Resolution																																											
Voltage	+/- 1%	1 [mV]																																											
Current	+/- 1%	1 [uA]																																											
Resistive	+/- 1%	1 [Ω]																																											
PWM	+/- 1% (<5kHz) +/- 2% (>5kHz)	0.01 [%]																																											
<p>Grounds</p>	<p>7 universal signal input grounds 1 PWM/digital signal ground 1 +5V reference ground</p>																																												
<p>Reference Voltages</p>	<p>1 +5V, 100 mA maximum Regulation at +/-0.5% accuracy is provided.</p>																																												

Output Specifications

Proportional Outputs	<p>8 High side sourcing up to 2.5A Half-bridge output, current sensing, grounded load High frequency PWM (25 kHz)</p> <p>Independent outputs (0...2.5A) are user selectable as:</p> <ul style="list-style-type: none"> • Output Disable • Proportional Current (See Table 3.0.) • Hotshot Digital • PWM Duty Cycle • Proportional Voltage • On/Off Digital (Normal, Inverse, Latched, Blinking Logic are selectable.) <p>Current outputs: 1 mA resolution Voltage outputs: 0.1V resolution PWM outputs: 0.1% resolution Digital on/off: Sourcing from power supply or output off (Note: Load at supply voltage must not draw more than 2.5A.)</p> <p>NB. The maximum total current draw permitted on the power supply input pins is 15 Amps @ 24Vdc, at one time.</p> <table border="1"> <thead> <tr> <th colspan="2">Table 3.0: Proportional Output Adjustments</th> </tr> <tr> <th>Adjustable Parameter</th> <th>Description</th> </tr> </thead> <tbody> <tr> <td>Output Current Adjustments</td> <td>0- I_{max} (2.5A) Both minimum and maximum current settings are user configurable.</td> </tr> <tr> <td>Superimposed Dither</td> <td>Dither adjustments are configurable for each channel. <u>Dither Amplitude:</u> 0 mA (factory default) Adjustable from 0-500 mA. <u>Dither Frequency:</u> 200 Hz (factory default) Adjustable from 50-400 Hz.</td> </tr> <tr> <td>Ramp Rates</td> <td>Ramp adjustments are configurable for each channel. 1,000 mSec (default) Adjustable from 0 to 10,000 mSec (10 sec.).</td> </tr> </tbody> </table>	Table 3.0: Proportional Output Adjustments		Adjustable Parameter	Description	Output Current Adjustments	0- I _{max} (2.5A) Both minimum and maximum current settings are user configurable.	Superimposed Dither	Dither adjustments are configurable for each channel. <u>Dither Amplitude:</u> 0 mA (factory default) Adjustable from 0-500 mA. <u>Dither Frequency:</u> 200 Hz (factory default) Adjustable from 50-400 Hz.	Ramp Rates	Ramp adjustments are configurable for each channel. 1,000 mSec (default) Adjustable from 0 to 10,000 mSec (10 sec.).
Table 3.0: Proportional Output Adjustments											
Adjustable Parameter	Description										
Output Current Adjustments	0- I _{max} (2.5A) Both minimum and maximum current settings are user configurable.										
Superimposed Dither	Dither adjustments are configurable for each channel. <u>Dither Amplitude:</u> 0 mA (factory default) Adjustable from 0-500 mA. <u>Dither Frequency:</u> 200 Hz (factory default) Adjustable from 50-400 Hz.										
Ramp Rates	Ramp adjustments are configurable for each channel. 1,000 mSec (default) Adjustable from 0 to 10,000 mSec (10 sec.).										
Output Accuracy	<p>Current outputs +/-1% Voltage outputs +/- 5% PWM outputs +/-0.1%</p>										
Digital Outputs	<p>4 High side switching outputs up to 3A (sourcing) Load current monitoring capability Fully protected Note: Outputs up to 5A are possible with a reduction in the operating temperature range.</p>										
Protection	<p>Overcurrent protection is provided on all outputs. Short circuit protection is provided on all outputs. Overvoltage and undervoltage protection is provided on all outputs.</p>										
Error Conditions	If an error on the input is detected, the output of the controller shuts off.										

General Specifications

Operating Conditions	-40 to 85°C (-40 to 185°F)
Weight	1.40 lb. (0.635 kg)
Protection	IP67; Unit is conformal coated within the housing.
Microprocessor	Model : AX020400A - STM32F427ZIT6, 2MByte flash memory, 256 KB RAM
Quiescent Current Draw	60 mA @ 24Vdc; 81 mA @ 12Vdc
CAN Interface	1 CAN port (SAE J1939) 250kbit/s, 500kbit/s, 667kbit/s, 1Mbit/s. Automatic Baud Rate Detection
Network Termination	It is necessary to terminate the network with external termination resistors. The resistors are 120 Ohm, 0.25W minimum, metal film or similar type. They should be placed between CAN_H and CAN_L terminals at both ends of the network.

Control Logic	<p>Standard embedded software is provided and is configurable using the Electronic Assistant (EA). Any of the outputs can be configured to use any of the inputs either as a control signal or an enable signal as well as use the CAN network data. The user can configure the control logic using the following Function Blocks.</p> <ul style="list-style-type: none"> • The Input Function Block allows the user to configure the input type. Normal, inverse and latched options are available for Universal and Digital input types. Pull-up or Pull-down resistors can be enabled or disabled for Frequency, PWM or Digital Input types. Frequency/RPM or PWM input types have a Debounce setpoint to select an input capture filter. Digital inputs can be configured as Active High or Active Low. Minimum and maximum range setpoints define the range of the signal input as a control source. Input filtering is selectable. • The Output Function Block allows for selection of each output type or output disable. Various setpoints by output type can be configured. Refer to the output specification and the user manual. • The Constant Data Function Block allows for a list of 10 constant data value to be used by the other function blocks. The EA configures the constant data points. • The Diagnostic Function Block supports SAE J1939 DM1, DM2, DM3, DM11, SPN, FMI, CM, and OC messages. Fault diagnostics are not available for the digital input types. In addition to input/output faults, the controller can detect and react to power supply fault, over temperature fault and communication fault. • The PID Control Function Block is associated with the proportional output type. • The Lookup Table Function Block is used to give output response up to 10 slopes per input. If more than 10 slopes are needed, then the Programmable Logic Function Block is used to combine up to 3 tables to generate up to 30 slopes. This is a powerful tool. Up to 3 different responses to the same input or three different responses to different inputs can become the input to another function block. • Math Function Blocks allow the user to define basic algorithms. Each of the 2 blocks can take up to 5 input signals which are then scaled according to an associated limit and scaling setpoints. For example, an output command from 0-100% can be generated from the combined positions of 2 inputs (a primary control input from a joystick and a speed potentiometer). • The DTC React Function Block allows for a received DTC from another device on the CAN network to disable an output or act as an input to a function block. • The CAN Transmit Function Block sends any output from another function block to the CAN network. Each CAN Transmit Message has several setpoints. Refer to the User Manual for details. By default, all messages are sent on Proprietary B PGN's as broadcast messages. • The CAN Receive Message Function Block is designed to take any SPN from the CAN network and use it as an input to another function block. <p>The EA will allow for the selection of any ECN Address from 0 to 253 (default is 128). Setpoint configuration files can be saved and used to program additional controllers. (Application-specific control logic is available on request.)</p>
User Interface	<p>User configuration and diagnostics are provided with the Axiomatic Electronic Assistant, p/n AX070502. The Axiomatic Service Tool is a <i>Windows</i>-based graphical user interface that allows easy configuration of the controller setpoints.</p>
Approvals	CE marking
Vibration	MIL-STD-202G, Test 204D and 214A (Sine and Random) 10 g peak (Sine), 7.65 Grms peak (Random)
Shock	MIL-STD-202G, Method 213B, test condition A 50g
Diagnostics	<p>Diagnostics messages are provided over the CAN network for the status of inputs or outputs. Each input or output channel could be configured to send diagnostic messages to the network if the I/O goes out of range. In addition to the I/O channels, one other type of fault can be reported to the network using diagnostic messaging, which is an Over Temperature fault (of the controller processor.) The controller stores diagnostic data in a non-volatile log.</p>

Enclosure and Dimensions	High Temperature Nylon housing, TE Deutsch (P/N: EEC-5X650B) 4.03 x 4.25 x 1.68 inches 102.44 x 107.96 x 42.67 mm L x W x H including integral connector Refer to the dimensional drawing.
Installation	<p>For mounting information, refer to the dimensional drawing.</p> <p>Mounting holes sized for ¼ inch or M6 bolts. The bolt length will be determined by the end-user's mounting plate thickness. The mounting flange of the controller is 0.25 inches (6.35 mm) thick. If the module is mounted without an enclosure, it should be mounted to reduce the likelihood of moisture entry. Install the unit with appropriate space available for servicing and for adequate wire harness access (6 inches or 15 cm) and strain relief (12 inches or 30 cm). Wires should be of the appropriate gauge to meet requirements of applicable electrical codes and suit the specifications of the connector.</p> <p>The module must be mounted in an enclosure in hazardous locations. All field wiring should be suitable for the operating temperature range of the module. All chassis grounding should go to a single ground point designated for the machine and all related equipment.</p>

Dimensional Drawing

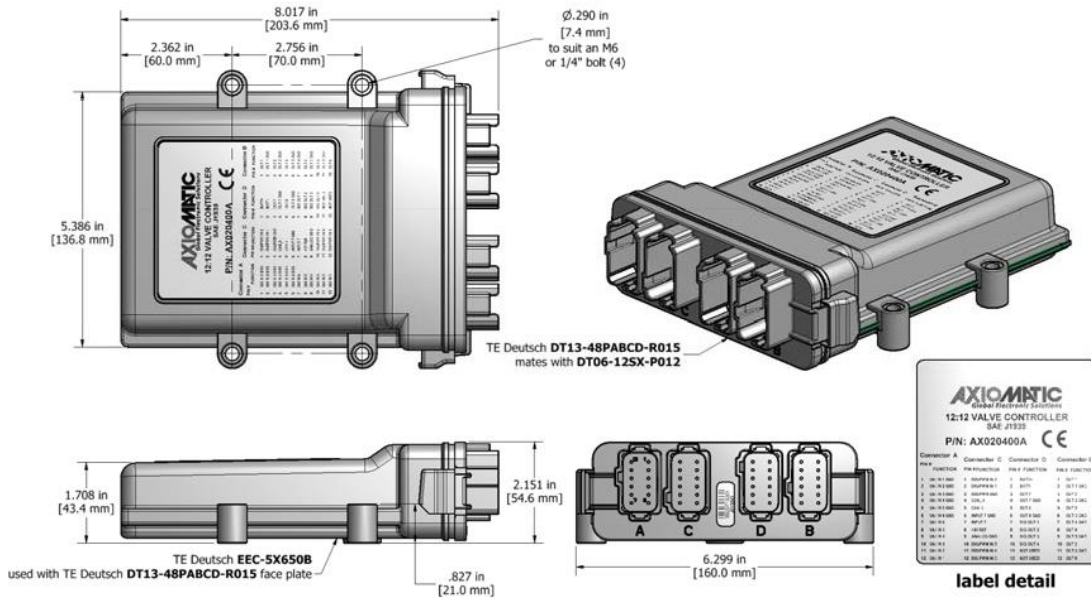

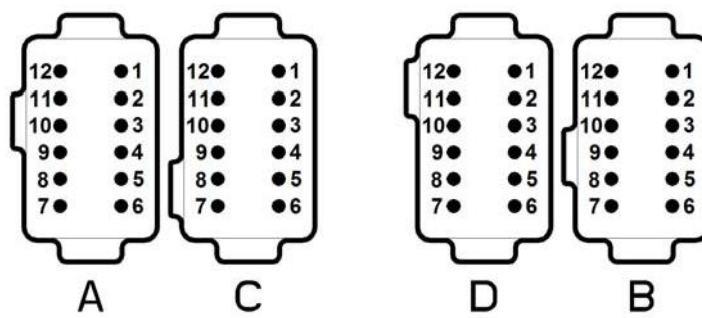
Electrical Connections	<p>48 pin TE Deutsch Connector (P/N: DT13-48PABCD-R015) or Amphenol Face Plate Connector (P/N: ATM13-12PA-12PB-BM03), based on availability.</p>  <table border="1" data-bbox="535 651 1388 997"> <thead> <tr> <th colspan="2">Connector A</th> <th colspan="2">Connector C</th> <th colspan="2">Connector D</th> <th colspan="2">Connector B</th> </tr> <tr> <th>Pin #</th> <th>Function</th> <th>Pin #</th> <th>Function</th> <th>Pin #</th> <th>Function</th> <th>Pin #</th> <th>Function</th> </tr> </thead> <tbody> <tr> <td>1</td> <td>UN IN 1 GND</td> <td>1</td> <td>DIG/PWM IN 2</td> <td>1</td> <td>BATT +</td> <td>1</td> <td>OUT 1</td> </tr> <tr> <td>2</td> <td>UN IN 2 GND</td> <td>2</td> <td>DIG/PWM IN 1</td> <td>2</td> <td>BATT -</td> <td>2</td> <td>OUT 1 GND</td> </tr> <tr> <td>3</td> <td>UN IN 3 GND</td> <td>3</td> <td>DIG/PWM GND</td> <td>3</td> <td>OUT 7</td> <td>3</td> <td>OUT 2</td> </tr> <tr> <td>4</td> <td>UN IN 4 GND</td> <td>4</td> <td>CAN_H</td> <td>4</td> <td>OUT 7 GND</td> <td>4</td> <td>OUT 2 GND</td> </tr> <tr> <td>5</td> <td>UN IN 5 GND</td> <td>5</td> <td>CAN_L</td> <td>5</td> <td>OUT 8</td> <td>5</td> <td>OUT 3</td> </tr> <tr> <td>6</td> <td>UN IN 6 GND</td> <td>6</td> <td>UN IN 7 GND</td> <td>6</td> <td>OUT 8 GND</td> <td>6</td> <td>OUT 3 GND</td> </tr> <tr> <td>7</td> <td>UN IN 6</td> <td>7</td> <td>INPUT 7</td> <td>7</td> <td>DIG OUT 1</td> <td>7</td> <td>OUT 4 GND</td> </tr> <tr> <td>8</td> <td>UN IN 5</td> <td>8</td> <td>+5V REF</td> <td>8</td> <td>DIG OUT 2</td> <td>8</td> <td>OUT 4</td> </tr> <tr> <td>9</td> <td>UN IN 4</td> <td>9</td> <td>+5V REF GND (AGND)</td> <td>9</td> <td>DIG OUT 3</td> <td>9</td> <td>OUT 5 GND</td> </tr> <tr> <td>10</td> <td>UN IN 3</td> <td>10</td> <td>DIG/PWM IN 5</td> <td>10</td> <td>DIG OUT 4</td> <td>10</td> <td>OUT 5</td> </tr> <tr> <td>11</td> <td>UN IN 2</td> <td>11</td> <td>DIG/PWM IN 4</td> <td>11</td> <td>NOT USED</td> <td>11</td> <td>OUT 6 GND</td> </tr> <tr> <td>12</td> <td>UN IN 1</td> <td>12</td> <td>DIG/PWM IN 3</td> <td>12</td> <td>NOT USED</td> <td>12</td> <td>OUT 6</td> </tr> </tbody> </table>	Connector A		Connector C		Connector D		Connector B		Pin #	Function	Pin #	Function	Pin #	Function	Pin #	Function	1	UN IN 1 GND	1	DIG/PWM IN 2	1	BATT +	1	OUT 1	2	UN IN 2 GND	2	DIG/PWM IN 1	2	BATT -	2	OUT 1 GND	3	UN IN 3 GND	3	DIG/PWM GND	3	OUT 7	3	OUT 2	4	UN IN 4 GND	4	CAN_H	4	OUT 7 GND	4	OUT 2 GND	5	UN IN 5 GND	5	CAN_L	5	OUT 8	5	OUT 3	6	UN IN 6 GND	6	UN IN 7 GND	6	OUT 8 GND	6	OUT 3 GND	7	UN IN 6	7	INPUT 7	7	DIG OUT 1	7	OUT 4 GND	8	UN IN 5	8	+5V REF	8	DIG OUT 2	8	OUT 4	9	UN IN 4	9	+5V REF GND (AGND)	9	DIG OUT 3	9	OUT 5 GND	10	UN IN 3	10	DIG/PWM IN 5	10	DIG OUT 4	10	OUT 5	11	UN IN 2	11	DIG/PWM IN 4	11	NOT USED	11	OUT 6 GND	12	UN IN 1	12	DIG/PWM IN 3	12	NOT USED	12	OUT 6
Connector A		Connector C		Connector D		Connector B																																																																																																											
Pin #	Function	Pin #	Function	Pin #	Function	Pin #	Function																																																																																																										
1	UN IN 1 GND	1	DIG/PWM IN 2	1	BATT +	1	OUT 1																																																																																																										
2	UN IN 2 GND	2	DIG/PWM IN 1	2	BATT -	2	OUT 1 GND																																																																																																										
3	UN IN 3 GND	3	DIG/PWM GND	3	OUT 7	3	OUT 2																																																																																																										
4	UN IN 4 GND	4	CAN_H	4	OUT 7 GND	4	OUT 2 GND																																																																																																										
5	UN IN 5 GND	5	CAN_L	5	OUT 8	5	OUT 3																																																																																																										
6	UN IN 6 GND	6	UN IN 7 GND	6	OUT 8 GND	6	OUT 3 GND																																																																																																										
7	UN IN 6	7	INPUT 7	7	DIG OUT 1	7	OUT 4 GND																																																																																																										
8	UN IN 5	8	+5V REF	8	DIG OUT 2	8	OUT 4																																																																																																										
9	UN IN 4	9	+5V REF GND (AGND)	9	DIG OUT 3	9	OUT 5 GND																																																																																																										
10	UN IN 3	10	DIG/PWM IN 5	10	DIG OUT 4	10	OUT 5																																																																																																										
11	UN IN 2	11	DIG/PWM IN 4	11	NOT USED	11	OUT 6 GND																																																																																																										
12	UN IN 1	12	DIG/PWM IN 3	12	NOT USED	12	OUT 6																																																																																																										
Mating Plugs	<p>Mates with the following TE Deutsch P/N's. DT06-12SA Plug, DT 12 Way A Key DT06-12SB Plug, DT 12 Way B Key DT06-12SC Plug, DT 12 Way C Key DT06-12SD Plug, DT 12 Way D Key A set of these mating plugs is available, ordering P/N: AX070123.</p>																																																																																																																

Specifications are indicative and subject to change. Actual performance will vary depending on the application and operating conditions. Users should satisfy themselves that the product is suitable for use in the intended application. All our products carry a limited warranty against defects in material and workmanship. Please refer to our Warranty, Application Approvals/Limitations and Return Materials Process as described on <https://www.axiomatic.com/service/>.

Notes:

CANopen® is a registered community trademark of CAN in Automation e.V.

Form: TDAX020400A-06/27/22