

10 Universal Signal Inputs CAN Controller

V, mA, Digital, PWM, Hz/RPM, Counter Inputs
1 Voltage Reference, CAN (SAE J1939)
with Electronic Assistant

P/N: AX030130

Features:

- 10 user selectable signal inputs:
 - 0-5 V
 - 0-10 V
 - 0-20 mA
 - 4-20 mA
 - PWM (low or high frequency)
 - Frequency/RPM
 - Counter
 - Digital
- +5V Reference, 100 mA
- 12V, 24Vdc (nominal) power input
- 1 CAN port (SAE J1939) with auto-baud-rate-detect
- Rugged packaging and connectors (TE Deutsch)
- Standard control logic
- CE mark (EMC Directive)
- Developed with Simulink®
- Electronic Assistant for parameter configuration



Description: The 10 Universal Signal Input Module accepts up to 10 analog or digital type inputs (0-5V, 0-10V, 0-20 mA or 4-20 mA, Digital, PWM, Frequency/RPM or Counter). The modules can be connected to a variety of analog machine sensors or levers, PLC's, switches, PWM signals, etc. It interfaces with the machine's CAN network (SAE J1939). Standard embedded software is provided. Rugged IP67 rated packaging in addition to a wide-ranging power supply input section for 12V or 24Vdc power suits applications in the harsh environment of mobile equipment with on-board battery power. All setpoints are user configurable using the Electronic Assistant.

Applications: The controller is designed to meet the rugged demands of construction equipment; power generator sets and heavy-duty industrial machine control applications.

Ordering Part Numbers:

10 Universal Signal Inputs, +5V Reference, 1 SAE J1939, Auto-baud-rate-detect P/N:
AX030130

Accessories:

PL-DTM06-12SA-12SB Mating Plug Kit (1 DTM06-12S, DTM06-12SB, 2 WM12S, 24 contacts)

Configuration Tool: Electronic Assistant P/N: **AX070502**

BLOCK DIAGRAM

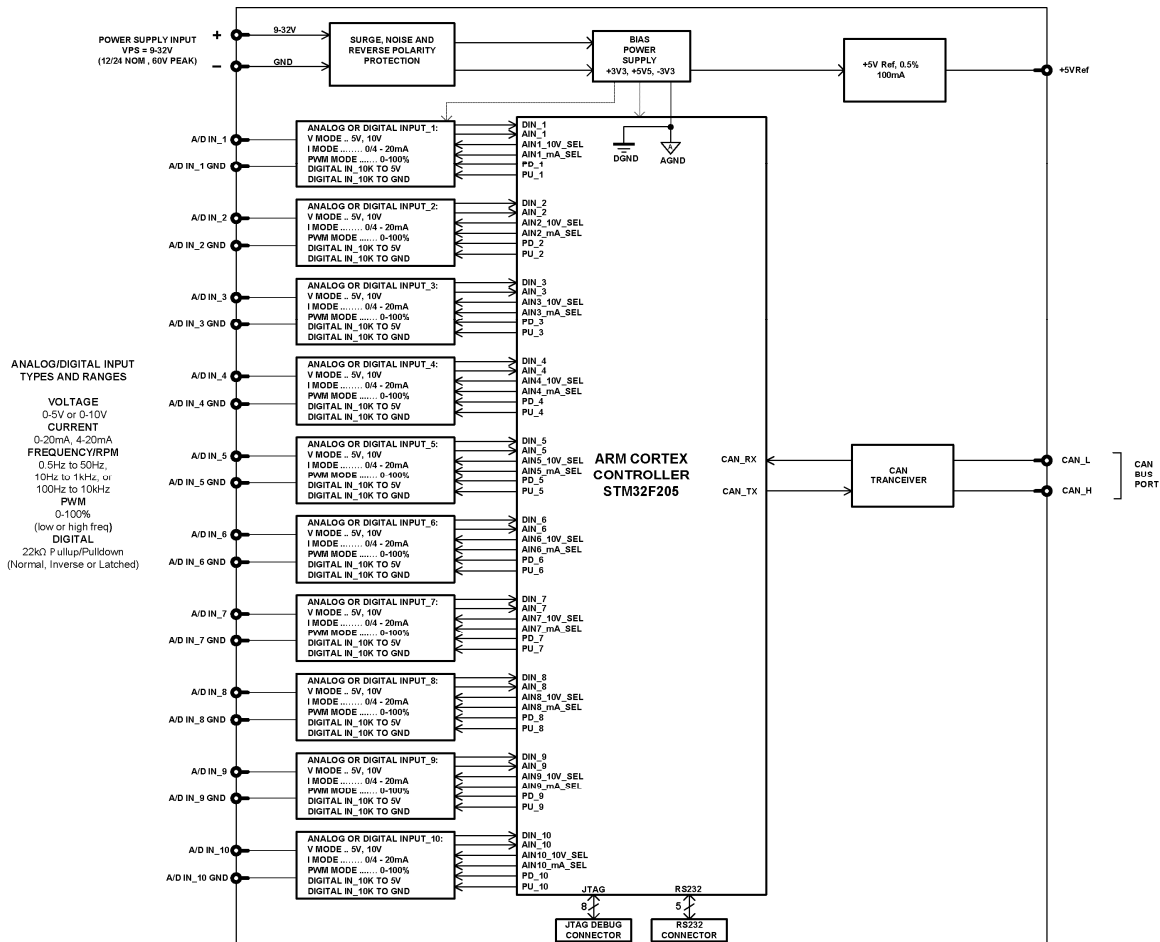

Technical Specifications:

Specifications are indicative and subject to change. Actual performance will vary depending on the application and operating conditions. Users should satisfy themselves that the product is suitable for use in the intended application. All our products carry a limited warranty against defects in material and workmanship. Please refer to our Warranty, Application Approvals/Limitations and Return Materials Process as described on www.axiomatic.com/service.html.

Power Input Specifications

| | |
|------------------------------|---|
| Power Supply Input - Nominal | 12 or 24Vdc nominal operating voltage 8...60 Vdc power supply range for voltage transients |
| Surge Protection | Provided |
| Reverse Polarity Protection | Provided |
| Quiescent Current | < 25mA @ Vin = 24V |
| Voltage Reference | +5V, 100 mA |

Signal Input Specifications

| Inputs | <p>10 user selectable inputs (See Table 1.0.)</p> <ul style="list-style-type: none"> Analog 12-bit (0-5V, 0-10V, 0-20 mA, 4-20 mA) PWM 12-bit (low or high frequency) Frequency/RPM Counter input 16-bit Digital (active high/active low) [ON when input $\geq 1.5V$] <p>The "Input Sensor Type" setpoint is used to configure input type.</p> <table border="1" data-bbox="602 443 1101 852"> <caption>Table 1.0. Inputs – Sensor Type Selections</caption> <thead> <tr> <th>Setpoint</th> <th>Input Type</th> </tr> </thead> <tbody> <tr><td>0</td><td>Disabled</td></tr> <tr><td>1</td><td>Voltage (0-5 V)</td></tr> <tr><td>13</td><td>Voltage (0-10 V)</td></tr> <tr><td>2</td><td>Current (0-20 mA)</td></tr> <tr><td>21</td><td>Current (4-20 mA)</td></tr> <tr><td>40</td><td>Frequency (0.5 to 50 Hz)</td></tr> <tr><td>41</td><td>Frequency (10 Hz to 1 kHz)</td></tr> <tr><td>4</td><td>Frequency (100 Hz to 10 kHz)</td></tr> <tr><td>3</td><td>PWM Low Frequency (<1 kHz)</td></tr> <tr><td>51</td><td>PWM High Frequency (>100 Hz)</td></tr> <tr><td>5</td><td>16-bit Counter</td></tr> <tr><td>6</td><td>Digital (normal)</td></tr> <tr><td>61</td><td>Digital (inverse)</td></tr> <tr><td>62</td><td>Digital (latched)</td></tr> </tbody> </table> <p>All inputs with the exception of 16-Bit Counter are sampled every 1ms. Analog Input types have a 12-bit resolution.</p> <p>With current inputs, short circuit protection is provided.</p> | Setpoint | Input Type | 0 | Disabled | 1 | Voltage (0-5 V) | 13 | Voltage (0-10 V) | 2 | Current (0-20 mA) | 21 | Current (4-20 mA) | 40 | Frequency (0.5 to 50 Hz) | 41 | Frequency (10 Hz to 1 kHz) | 4 | Frequency (100 Hz to 10 kHz) | 3 | PWM Low Frequency (<1 kHz) | 51 | PWM High Frequency (>100 Hz) | 5 | 16-bit Counter | 6 | Digital (normal) | 61 | Digital (inverse) | 62 | Digital (latched) | | | | | | | | | | |
|------------------------------------|---|----------------|------------|------------|----------|--------------|-----------------|---------|------------------|---------------|-------------------|----------------------------------|-------------------|---------------|--------------------------|-----------|----------------------------|-------------------------------|------------------------------|----|----------------------------|------------------------------------|------------------------------|----|----------------|----------------|------------------|-----|-------------------|---------------|-------------------|--------|----|---------------------|---|----|------|---------------|----|--------|----|
| Setpoint | Input Type | | | | | | | | | | | | | | | | | | | | | | | | | | | | | | | | | | | | | | | | |
| 0 | Disabled | | | | | | | | | | | | | | | | | | | | | | | | | | | | | | | | | | | | | | | | |
| 1 | Voltage (0-5 V) | | | | | | | | | | | | | | | | | | | | | | | | | | | | | | | | | | | | | | | | |
| 13 | Voltage (0-10 V) | | | | | | | | | | | | | | | | | | | | | | | | | | | | | | | | | | | | | | | | |
| 2 | Current (0-20 mA) | | | | | | | | | | | | | | | | | | | | | | | | | | | | | | | | | | | | | | | | |
| 21 | Current (4-20 mA) | | | | | | | | | | | | | | | | | | | | | | | | | | | | | | | | | | | | | | | | |
| 40 | Frequency (0.5 to 50 Hz) | | | | | | | | | | | | | | | | | | | | | | | | | | | | | | | | | | | | | | | | |
| 41 | Frequency (10 Hz to 1 kHz) | | | | | | | | | | | | | | | | | | | | | | | | | | | | | | | | | | | | | | | | |
| 4 | Frequency (100 Hz to 10 kHz) | | | | | | | | | | | | | | | | | | | | | | | | | | | | | | | | | | | | | | | | |
| 3 | PWM Low Frequency (<1 kHz) | | | | | | | | | | | | | | | | | | | | | | | | | | | | | | | | | | | | | | | | |
| 51 | PWM High Frequency (>100 Hz) | | | | | | | | | | | | | | | | | | | | | | | | | | | | | | | | | | | | | | | | |
| 5 | 16-bit Counter | | | | | | | | | | | | | | | | | | | | | | | | | | | | | | | | | | | | | | | | |
| 6 | Digital (normal) | | | | | | | | | | | | | | | | | | | | | | | | | | | | | | | | | | | | | | | | |
| 61 | Digital (inverse) | | | | | | | | | | | | | | | | | | | | | | | | | | | | | | | | | | | | | | | | |
| 62 | Digital (latched) | | | | | | | | | | | | | | | | | | | | | | | | | | | | | | | | | | | | | | | | |
| Minimum and Maximum Ratings | <table border="1" data-bbox="613 972 1214 1318"> <caption>Table 2.0. Absolute Maximum and Minimum Ratings</caption> <thead> <tr> <th>Characteristic</th> <th>Min</th> <th>Max</th> <th>Units</th> </tr> </thead> <tbody> <tr><td>Power Supply</td><td>8</td><td>60</td><td>V dc</td></tr> <tr><td>Voltage Input</td><td>0</td><td>43</td><td>V dc</td></tr> <tr><td>Current Input</td><td>0</td><td>21</td><td>mA</td></tr> <tr><td>Current Input – Voltage Level</td><td>0</td><td>12</td><td>Vdc</td></tr> <tr><td>Digital Type Input – Voltage Level</td><td>0</td><td>43</td><td>Vdc</td></tr> <tr><td>PWM Duty Cycle</td><td>0</td><td>100</td><td>%</td></tr> <tr><td>PWM Frequency</td><td>50</td><td>10 000</td><td>Hz</td></tr> <tr><td>PWM Voltage pk - pk</td><td>0</td><td>43</td><td>V dc</td></tr> <tr><td>RPM Frequency</td><td>50</td><td>10 000</td><td>Hz</td></tr> </tbody> </table> | Characteristic | Min | Max | Units | Power Supply | 8 | 60 | V dc | Voltage Input | 0 | 43 | V dc | Current Input | 0 | 21 | mA | Current Input – Voltage Level | 0 | 12 | Vdc | Digital Type Input – Voltage Level | 0 | 43 | Vdc | PWM Duty Cycle | 0 | 100 | % | PWM Frequency | 50 | 10 000 | Hz | PWM Voltage pk - pk | 0 | 43 | V dc | RPM Frequency | 50 | 10 000 | Hz |
| Characteristic | Min | Max | Units | | | | | | | | | | | | | | | | | | | | | | | | | | | | | | | | | | | | | | |
| Power Supply | 8 | 60 | V dc | | | | | | | | | | | | | | | | | | | | | | | | | | | | | | | | | | | | | | |
| Voltage Input | 0 | 43 | V dc | | | | | | | | | | | | | | | | | | | | | | | | | | | | | | | | | | | | | | |
| Current Input | 0 | 21 | mA | | | | | | | | | | | | | | | | | | | | | | | | | | | | | | | | | | | | | | |
| Current Input – Voltage Level | 0 | 12 | Vdc | | | | | | | | | | | | | | | | | | | | | | | | | | | | | | | | | | | | | | |
| Digital Type Input – Voltage Level | 0 | 43 | Vdc | | | | | | | | | | | | | | | | | | | | | | | | | | | | | | | | | | | | | | |
| PWM Duty Cycle | 0 | 100 | % | | | | | | | | | | | | | | | | | | | | | | | | | | | | | | | | | | | | | | |
| PWM Frequency | 50 | 10 000 | Hz | | | | | | | | | | | | | | | | | | | | | | | | | | | | | | | | | | | | | | |
| PWM Voltage pk - pk | 0 | 43 | V dc | | | | | | | | | | | | | | | | | | | | | | | | | | | | | | | | | | | | | | |
| RPM Frequency | 50 | 10 000 | Hz | | | | | | | | | | | | | | | | | | | | | | | | | | | | | | | | | | | | | | |
| Input Accuracy | <table border="1" data-bbox="613 1335 1295 1585"> <caption>Table 3.0. Input Accuracy</caption> <thead> <tr> <th>Input Type</th> <th>Accuracy</th> <th>Resolution</th> </tr> </thead> <tbody> <tr><td>Voltage</td><td>+/- 1%</td><td>1 [mV]</td></tr> <tr><td>Current</td><td>+/- 1%</td><td>1 [uA]</td></tr> <tr><td>PWM</td><td>+/- 1% (<5kHz) +/- 2% (>5kHz)</td><td>0.1 [%]</td></tr> <tr><td>Frequency/RPM</td><td>+/- 1%</td><td>0.01 [Hz]</td></tr> </tbody> </table> | Input Type | Accuracy | Resolution | Voltage | +/- 1% | 1 [mV] | Current | +/- 1% | 1 [uA] | PWM | +/- 1% (<5kHz) +/- 2% (>5kHz) | 0.1 [%] | Frequency/RPM | +/- 1% | 0.01 [Hz] | | | | | | | | | | | | | | | | | | | | | | | | | |
| Input Type | Accuracy | Resolution | | | | | | | | | | | | | | | | | | | | | | | | | | | | | | | | | | | | | | | |
| Voltage | +/- 1% | 1 [mV] | | | | | | | | | | | | | | | | | | | | | | | | | | | | | | | | | | | | | | | |
| Current | +/- 1% | 1 [uA] | | | | | | | | | | | | | | | | | | | | | | | | | | | | | | | | | | | | | | | |
| PWM | +/- 1% (<5kHz) +/- 2% (>5kHz) | 0.1 [%] | | | | | | | | | | | | | | | | | | | | | | | | | | | | | | | | | | | | | | | |
| Frequency/RPM | +/- 1% | 0.01 [Hz] | | | | | | | | | | | | | | | | | | | | | | | | | | | | | | | | | | | | | | | |
| Input Impedance | <p>0-5V: 1 MOhm 0-10V: 170 kOhm 0(4)-20mA: 249 Ohm Frequency/Digital Input: Pull Up/Pull Down 22 KOhm</p> | | | | | | | | | | | | | | | | | | | | | | | | | | | | | | | | | | | | | | | | |
| Scan Rate | <p>Each input is scanned in 100uS. A complete scan of 10 inputs occurs with new measured values every 1mS.</p> | | | | | | | | | | | | | | | | | | | | | | | | | | | | | | | | | | | | | | | | |
| Analog GND | <p>10 Analog GND connections are provided. Grounds are connected internally.</p> | | | | | | | | | | | | | | | | | | | | | | | | | | | | | | | | | | | | | | | | |

General Specifications

| | |
|---------------------|---|
| Microprocessor | STM32F205VGT6 |
| Communications | 1 CAN port (2.0B, SAE J1939) 250kbit/s, 500kbit/s, 667kbit/s, 1Mbit/s. Automatic Baud Rate Detection A CANopen® model is available (PN AX030121). An on-board RS-232 port is used for factory programming only. |
| EMC Compliance | CE marking |
| Vibration | MIL-STD-202G, Method 204D, test condition A – 10 g peak (Sine) MIL-STD-202G, Method 214A, test condition B – 7.68 Grms (Random) |
| Shock | MIL-STD-202G, Method 213B, test condition A 50 g half sine pulse, 6 ms, 6 pulses per axis |
| User Interface | User configuration and diagnostics are provided with the Axiomatic Electronic Assistant. |
| Network Termination | It is necessary to terminate the network with external termination resistors. The resistors are 120 Ohm, 0.25W minimum, metal film or similar type. They should be placed between CAN_H and CAN_L terminals at both ends of the network. |
| Control Logic | <p>Configurable properties of the controller are divided into function blocks, namely input function block, diagnostic function block; lookup table function block, programmable logic function block, math function block, CAN receive message function block and CAN transmit message function block. Input function block includes properties used to select input sensor functionality. Diagnostic function block properties are used to configure fault detection and reaction functionalities. The Math function block gives user an opportunity to process inputs with basic mathematical or logical functions. The CAN transmit message function block configures properties of the messages sent to the CAN bus.</p> <p>The software was designed to provide flexibility to the user with respect to messages sent from the module (ECU) over the CAN bus, by providing:</p> <ul style="list-style-type: none"> • Configurable ECU Instance in the NAME (to allow multiple ECU's on the same network) • Configurable Input Parameters • Configurable PGN and Data Parameters • Configurable Diagnostic Messaging Parameters, as required • Diagnostic Log, maintained in non-volatile memory <p>The CAN Transmit function block is used to send any output from another function block (i.e. input, math) to the J1939 network. The AX030130 ECU has ten CAN Transmit Messages and each message has 5 signals.</p> <p>The “Transmit PGN” setpoint sets PGN used with the message. The user should be familiar with the SAE J1939 standard and select values for PGN/SPN combinations as appropriate from section J1939/71. By default, all messages are sent on Proprietary B PGNs as broadcast messages.</p> <p>None of the application layer PGNs are supported as part of the default configurations, but they can be selected as desired for transmit function blocks.</p> <p>Setpoints are accessed using standard Memory Access Protocol (MAP) with proprietary addresses. The Electronic Assistant (EA) allows for quick and easy configuration of the unit over CAN network.</p> <p>Refer to the User Manual UMAX030130 for details. The AX030130 can be upgraded with new application firmware over the CAN bus using the Electronic Assistant. <i>For application-specific control logic, contact Axiomatic.</i></p> |

| SAE J1939 Compliance | <p>The ECU is compliant with the following SAE J1939 standards.</p> <ul style="list-style-type: none"> • J1939 Recommended Practice for a Serial Control and Communications Vehicle Network, SAE, April 2011 • J1939/21 Data Link Layer, SAE, December 2010 • J1939/71 Vehicle Application Layer, SAE, March 2011 • J1939/73 Application Layer-Diagnostics, SAE, February 2010 • J1939/81 Network Management, SAE, May 2003 <p>It supports following PGNs from the standard.</p> <table border="1"> <thead> <tr> <th colspan="4">Table 4.0. SAE J1939 PGNs</th> </tr> </thead> <tbody> <tr> <td colspan="4">From J1939-21 – Data Link Layer</td> </tr> <tr> <td></td> <td>Request</td> <td>59904</td> <td>0x00EA00</td> </tr> <tr> <td></td> <td>Acknowledgement</td> <td>59392</td> <td>0x00E800</td> </tr> <tr> <td></td> <td>Transport Protocol – Connection Management</td> <td>60416</td> <td>0x00EC00</td> </tr> <tr> <td></td> <td>Transport Protocol – Data Transfer Message</td> <td>60160</td> <td>0x00EB00</td> </tr> <tr> <td></td> <td rowspan="2">Proprietary B</td> <td>From 65280</td> <td>0x00FF00</td> </tr> <tr> <td></td> <td>To 65535</td> <td>0x00FFFF</td> </tr> <tr> <td colspan="4">From J1939-73 – Diagnostics</td> </tr> <tr> <td></td> <td>DM1 – Active Diagnostic Trouble Codes</td> <td>65226</td> <td>0x00FECA</td> </tr> <tr> <td></td> <td>DM2 – Previously Active Diagnostic Trouble Codes</td> <td>65227</td> <td>0x00FECB</td> </tr> <tr> <td></td> <td>DM3 – Diagnostic Data Clear/Reset for Previously Active DTCs</td> <td>65228</td> <td>0x00FECC</td> </tr> <tr> <td></td> <td>DM11 – Diagnostic Data Clear/Reset for Active DTCs</td> <td>65235</td> <td>0x00FED3</td> </tr> <tr> <td colspan="4">From J1939-81 – Network Management</td> </tr> <tr> <td></td> <td>Address Claimed/Cannot Claim</td> <td>60928</td> <td>0x00EE00</td> </tr> <tr> <td></td> <td>Commanded Address</td> <td>65240</td> <td>0x00FED8</td> </tr> <tr> <td colspan="4">From J1939-71 – Vehicle Application Layer</td> </tr> <tr> <td></td> <td>Software Identification</td> <td>65242</td> <td>0x00FEDA</td> </tr> </tbody> </table> | Table 4.0. SAE J1939 PGNs | | | | From J1939-21 – Data Link Layer | | | | | Request | 59904 | 0x00EA00 | | Acknowledgement | 59392 | 0x00E800 | | Transport Protocol – Connection Management | 60416 | 0x00EC00 | | Transport Protocol – Data Transfer Message | 60160 | 0x00EB00 | | Proprietary B | From 65280 | 0x00FF00 | | To 65535 | 0x00FFFF | From J1939-73 – Diagnostics | | | | | DM1 – Active Diagnostic Trouble Codes | 65226 | 0x00FECA | | DM2 – Previously Active Diagnostic Trouble Codes | 65227 | 0x00FECB | | DM3 – Diagnostic Data Clear/Reset for Previously Active DTCs | 65228 | 0x00FECC | | DM11 – Diagnostic Data Clear/Reset for Active DTCs | 65235 | 0x00FED3 | From J1939-81 – Network Management | | | | | Address Claimed/Cannot Claim | 60928 | 0x00EE00 | | Commanded Address | 65240 | 0x00FED8 | From J1939-71 – Vehicle Application Layer | | | | | Software Identification | 65242 | 0x00FEDA |
|--|--|---------------------------|----------|--|--|--|--|--|--|--|---------|-------|----------|--|-----------------|-------|----------|--|--|-------|----------|--|--|-------|----------|--|---------------|------------|----------|--|----------|----------|------------------------------------|--|--|--|--|---------------------------------------|-------|----------|--|--|-------|----------|--|--|-------|----------|--|--|-------|----------|---|--|--|--|--|------------------------------|-------|----------|--|-------------------|-------|----------|--|--|--|--|--|-------------------------|-------|----------|
| Table 4.0. SAE J1939 PGNs | | | | | | | | | | | | | | | | | | | | | | | | | | | | | | | | | | | | | | | | | | | | | | | | | | | | | | | | | | | | | | | | | | | | | | | | |
| From J1939-21 – Data Link Layer | | | | | | | | | | | | | | | | | | | | | | | | | | | | | | | | | | | | | | | | | | | | | | | | | | | | | | | | | | | | | | | | | | | | | | | | |
| | Request | 59904 | 0x00EA00 | | | | | | | | | | | | | | | | | | | | | | | | | | | | | | | | | | | | | | | | | | | | | | | | | | | | | | | | | | | | | | | | | | | | | |
| | Acknowledgement | 59392 | 0x00E800 | | | | | | | | | | | | | | | | | | | | | | | | | | | | | | | | | | | | | | | | | | | | | | | | | | | | | | | | | | | | | | | | | | | | | |
| | Transport Protocol – Connection Management | 60416 | 0x00EC00 | | | | | | | | | | | | | | | | | | | | | | | | | | | | | | | | | | | | | | | | | | | | | | | | | | | | | | | | | | | | | | | | | | | | | |
| | Transport Protocol – Data Transfer Message | 60160 | 0x00EB00 | | | | | | | | | | | | | | | | | | | | | | | | | | | | | | | | | | | | | | | | | | | | | | | | | | | | | | | | | | | | | | | | | | | | | |
| | Proprietary B | From 65280 | 0x00FF00 | | | | | | | | | | | | | | | | | | | | | | | | | | | | | | | | | | | | | | | | | | | | | | | | | | | | | | | | | | | | | | | | | | | | | |
| | | To 65535 | 0x00FFFF | | | | | | | | | | | | | | | | | | | | | | | | | | | | | | | | | | | | | | | | | | | | | | | | | | | | | | | | | | | | | | | | | | | | | |
| From J1939-73 – Diagnostics | | | | | | | | | | | | | | | | | | | | | | | | | | | | | | | | | | | | | | | | | | | | | | | | | | | | | | | | | | | | | | | | | | | | | | | | |
| | DM1 – Active Diagnostic Trouble Codes | 65226 | 0x00FECA | | | | | | | | | | | | | | | | | | | | | | | | | | | | | | | | | | | | | | | | | | | | | | | | | | | | | | | | | | | | | | | | | | | | | |
| | DM2 – Previously Active Diagnostic Trouble Codes | 65227 | 0x00FECB | | | | | | | | | | | | | | | | | | | | | | | | | | | | | | | | | | | | | | | | | | | | | | | | | | | | | | | | | | | | | | | | | | | | | |
| | DM3 – Diagnostic Data Clear/Reset for Previously Active DTCs | 65228 | 0x00FECC | | | | | | | | | | | | | | | | | | | | | | | | | | | | | | | | | | | | | | | | | | | | | | | | | | | | | | | | | | | | | | | | | | | | | |
| | DM11 – Diagnostic Data Clear/Reset for Active DTCs | 65235 | 0x00FED3 | | | | | | | | | | | | | | | | | | | | | | | | | | | | | | | | | | | | | | | | | | | | | | | | | | | | | | | | | | | | | | | | | | | | | |
| From J1939-81 – Network Management | | | | | | | | | | | | | | | | | | | | | | | | | | | | | | | | | | | | | | | | | | | | | | | | | | | | | | | | | | | | | | | | | | | | | | | | |
| | Address Claimed/Cannot Claim | 60928 | 0x00EE00 | | | | | | | | | | | | | | | | | | | | | | | | | | | | | | | | | | | | | | | | | | | | | | | | | | | | | | | | | | | | | | | | | | | | | |
| | Commanded Address | 65240 | 0x00FED8 | | | | | | | | | | | | | | | | | | | | | | | | | | | | | | | | | | | | | | | | | | | | | | | | | | | | | | | | | | | | | | | | | | | | | |
| From J1939-71 – Vehicle Application Layer | | | | | | | | | | | | | | | | | | | | | | | | | | | | | | | | | | | | | | | | | | | | | | | | | | | | | | | | | | | | | | | | | | | | | | | | |
| | Software Identification | 65242 | 0x00FEDA | | | | | | | | | | | | | | | | | | | | | | | | | | | | | | | | | | | | | | | | | | | | | | | | | | | | | | | | | | | | | | | | | | | | | |

| | |
|--------------------------|--|
| Diagnostics | The 10 Universal Input ECU supports diagnostic messaging. DM1 message is a message, containing Active Diagnostic Trouble Codes (DTC) that is sent to the J1939 network in case a fault has been detected. The Universal Inputs setpoint group includes diagnostic related setpoints. There are three additional fault diagnostic setpoint groups namely Over Temperature, Over Voltage and Under Voltage. |
| Electrical Connections | TE Deutsch DTM series 24 pin receptacle (DTM13-12PA-12PB-R008) Mating plug: TE Deutsch DTM06-12SA and DTM06-12SB with 2 wedgelocks (WM12S) and 24 contacts (0462-201-20141). 20 AWG wire is recommended for use with contacts 0462-201-20141. |
| Enclosure and Dimensions | High Temperature Nylon housing – TE Deutsch PCB Enclosure (EEC-325X4B) 4.677 x 5.236 x 1.417 inches 118.80 x 133.00 x 36.00 mm (W x L x H excluding mating plugs) |
| Operating Conditions | -40 to 85°C (-40 to 185°F) |
| Weight | 0.55 lb. (0.25 kg) |
| Protection | IP67, Unit is conformal coated in the housing. |
| Mounting | Mounting holes sized for ¼ inch or M6 bolts. The bolt length will be determined by the end-user's mounting plate thickness. The mounting flange of the controller is 0.63 inches (16 mm) thick. If the module is mounted without an enclosure, it should be mounted vertically with connectors facing left and right to reduce likelihood of moisture entry. The CAN wiring is considered intrinsically safe. The power wires are not considered intrinsically safe and so in hazardous locations, they need to be located in conduit or conduit trays at all times. The module must be mounted in an enclosure in hazardous locations for this purpose. All field wiring should be suitable for the operating temperature range. Install the unit with appropriate space available for servicing and for adequate wire harness access (6 inches or 15 cm) and strain relief (12 inches or 30 cm). |

Dimensions and Typical Connections:

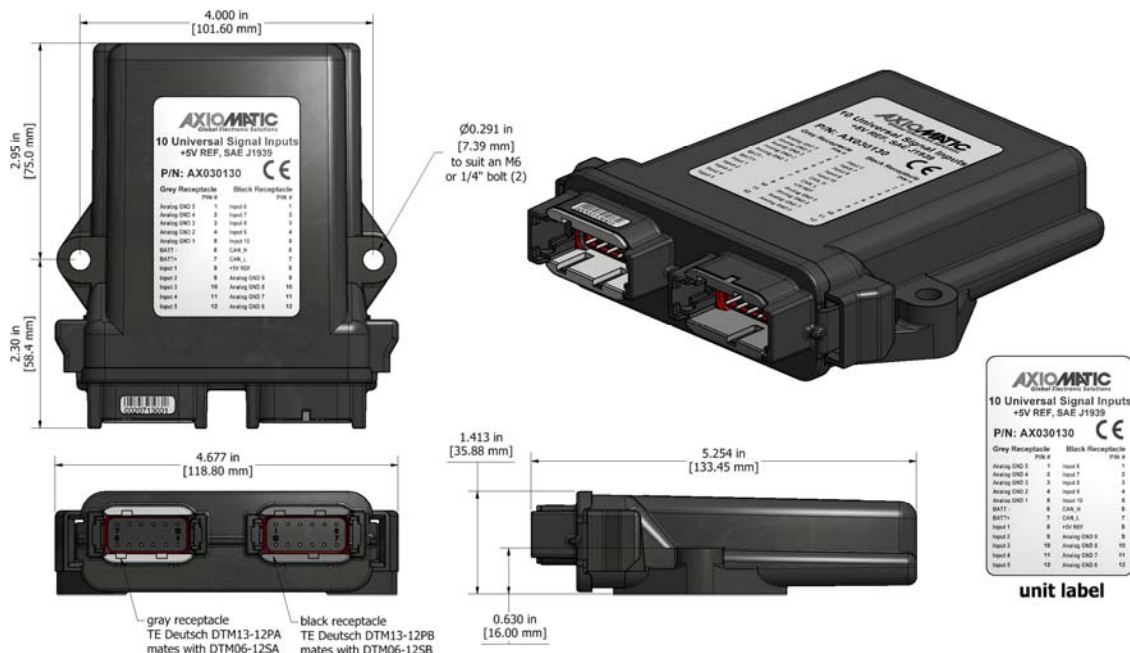

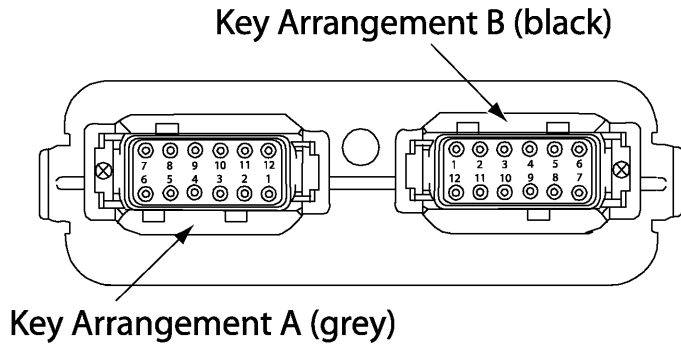

FRONT VIEW 24 PIN RECEPTACLE

| Table 5.0. Electrical Pin Out | | | |
|--------------------------------------|-----------------|------------------------|-----------------|
| Grey Connector | | Black Connector | |
| Pin # | Function | Pin # | Function |
| 1 | Analog GND 5 | 1 | Input 6 |
| 2 | Analog GND 4 | 2 | Input 7 |
| 3 | Analog GND 3 | 3 | Input 8 |
| 4 | Analog GND 2 | 4 | Input 9 |
| 5 | Analog GND 1 | 5 | Input 10 |
| 6 | Batt - | 6 | CAN_H |
| 7 | Batt + | 7 | CAN_L |
| 8 | Input 1 | 8 | +5V Reference |
| 9 | Input 2 | 9 | Analog GND 9 |
| 10 | Input 3 | 10 | Analog GND 8 |
| 11 | Input 4 | 11 | Analog GND 7 |
| 12 | Input 5 | 12 | Analog GND 6 |

Notes:

CANopen® is a registered community trademark of CAN in Automation e.V.

Form: TDAX030130-09/20/19