

RS-232 to CAN Converter with Two Digital Inputs

2 Digital Signal Inputs
2 Isolated CAN (SAE J1939)
1 R-232
with Electronic Assistant

P/N: AX030350

Features:

- Two digital input signals
- Two isolated CAN SAE J1939 ports
- 1 R-232 port
- 12V or 24V nominal power
- Compact Enclosure, 12-pin TE Deutsch Connector
- Operates from -40°C to +85°C

Application:

Interfaces RS-232 satellite phones or GPS systems with CAN bus in on-road commercial vehicles



Ordering Part Numbers:

Two Digital IN CAN Controller, 2 SAE J1939 with auto-baud-rate detect, 1 RS-232: **AX030350**
Two Digital Inputs CAN Controller, 2 CANopen®, 1 RS-232: **AX030351**

Accessories:

Mating Plug Kit: **PL-DTM06-12SA**
Electronic Assistant: **AX070502**

Block Diagram

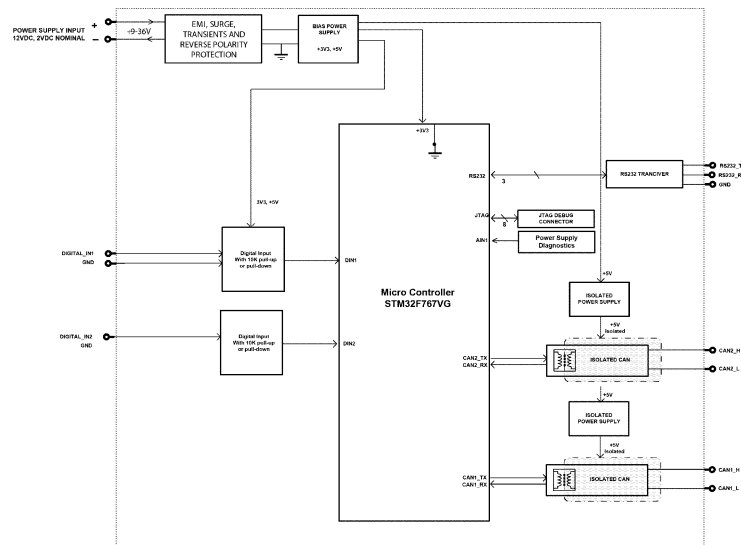

Technical Specifications:

Specifications are indicative and subject to change. Actual performance will vary depending on the application and operating conditions. Users should satisfy themselves that the product is suitable for use in the intended application. All our products carry a limited warranty against defects in material and workmanship. Please refer to our Warranty, Application Approvals/Limitations and Return Materials Process as described <https://www.axiomatic.com/service/>.

Power Supply

Power Supply Input	12 Vdc or 24 Vdc nominal 9...36 Vdc power supply range
Protection	Reverse polarity protection up to -50V. Undervoltage shutdown at 6Vdc. Overvoltage protection is up to 38 V.

Inputs

Inputs	2 Digital Inputs Active High up to +Vps or Active Low to Ground Selectable 10 kOhm pull-up or pull-down Amplitude: 0V to +Vsupply
Input Grounds	1 provided
Protection	All inputs are protected against short to GND. All inputs are protected against shorts to Nominal Vps (36Vdc).

General Specifications

Microprocessor	STM32F767VG
Isolation	300 Vrms Isolation is between CAN and power/inputs.
Typical Quiescent Current	75 mA @ 12Vdc typical; 39 mA @ 24Vdc typical
Control Logic	Standard embedded software is provided. <i>(Application-specific control logic or a set point file is available on request.)</i>
Communications	2 Isolated CAN ports (SAE J1939) (CANopen® on request) 1 RS-232 port
Baud Rate	CAN Baud rate: 250, 500, 667 kbit/s, 1 Mbit/s. Automatic baud rate detection.
Network Termination	It is necessary to terminate the network with external termination resistors. The resistors are 120 Ohm, 0.25W minimum, metal film or similar type. They should be placed between CAN_H and CAN_L terminals at both ends of the network.
User Interface and Software Reflashing	The Electronic Assistant, P/N: AX070502 , for <i>Windows</i> operating systems comes with a royalty-free license for use on multiple computers. It includes an Axiomatic USB-CAN converter to link the device's CAN port to a <i>Windows</i> -based PC.
Operating Conditions	-40 to 85 °C (-40 to 185 °F)
Storage Temperature	-55 to 125 °C (-67 to 257°F)
Protection	IP67
Vibration	MIL-STD-202G, Test 204D and 214A (Sine and Random) 10 g peak (Sine) 7.86 Grms peak (Random)
Shock	MIL-STD-202G, Test 213B 50g
Weight	0.15 lb. (0.068 kg) preliminary
Enclosure	Molded Enclosure, integral connector Nylon 6/6, 30% glass Ultrasonically welded 3.54 x 2.75 x 1.31 inches (90.09 x 70.00 x 33.35 mm) L x W x H including integral connector Refer to the dimensional drawing.

Electrical Connections	Integral TE Deutsch 12 pin receptacle (P/N: DTM04-12PA)																									
	<table border="1"> <thead> <tr> <th>PIN #</th> <th>FUNCTION</th> </tr> </thead> <tbody> <tr><td>1</td><td>BATT -</td></tr> <tr><td>2</td><td>CAN 2_H</td></tr> <tr><td>3</td><td>CAN 2_L</td></tr> <tr><td>4</td><td>RS-232_Rx</td></tr> <tr><td>5</td><td>RS-232_Tx</td></tr> <tr><td>6</td><td>CAN 1_H</td></tr> <tr><td>7</td><td>CAN 1_L</td></tr> <tr><td>8</td><td>Digital IN 2</td></tr> <tr><td>9</td><td>Digital IN 1</td></tr> <tr><td>10</td><td>GND</td></tr> <tr><td>11</td><td>CAN 2_SH</td></tr> <tr><td>12</td><td>BATT +</td></tr> </tbody> </table>	PIN #	FUNCTION	1	BATT -	2	CAN 2_H	3	CAN 2_L	4	RS-232_Rx	5	RS-232_Tx	6	CAN 1_H	7	CAN 1_L	8	Digital IN 2	9	Digital IN 1	10	GND	11	CAN 2_SH	12
PIN #	FUNCTION																									
1	BATT -																									
2	CAN 2_H																									
3	CAN 2_L																									
4	RS-232_Rx																									
5	RS-232_Tx																									
6	CAN 1_H																									
7	CAN 1_L																									
8	Digital IN 2																									
9	Digital IN 1																									
10	GND																									
11	CAN 2_SH																									
12	BATT +																									
Mating Plug Kit	PL-DTM06-12SA Mating Plug Kit :1 DTM06-12SA, 1 WM-12S, 12 0462-201-20141, 6 0413-204-2005 Sealing Plug																									
Mounting	<p>Mounting holes are sized for #8 or M4 bolts. The bolt length will be determined by the end-user's mounting plate thickness. The mounting flange of the controller is 0.425 inches (10.8 mm) thick.</p> <p>If the module is mounted without an enclosure, it should be mounted vertically with connectors facing left or right to reduce likelihood of moisture entry.</p> <p>The CAN wiring is considered intrinsically safe. The power wires are not considered intrinsically safe and so in hazardous locations, they need to be located in conduit or conduit trays at all times. The module must be mounted in an enclosure in hazardous locations for this purpose.</p> <p>No wire or cable harness should exceed 30 meters in length. The power input wiring should be limited to 10 meters.</p> <p>All field wiring should be suitable for the operating temperature range.</p> <p>Install the unit with appropriate space available for servicing and for adequate wire harness access (6 inches or 15 cm) and strain relief (12 inches or 30 cm).</p>																									

Dimensional Drawing

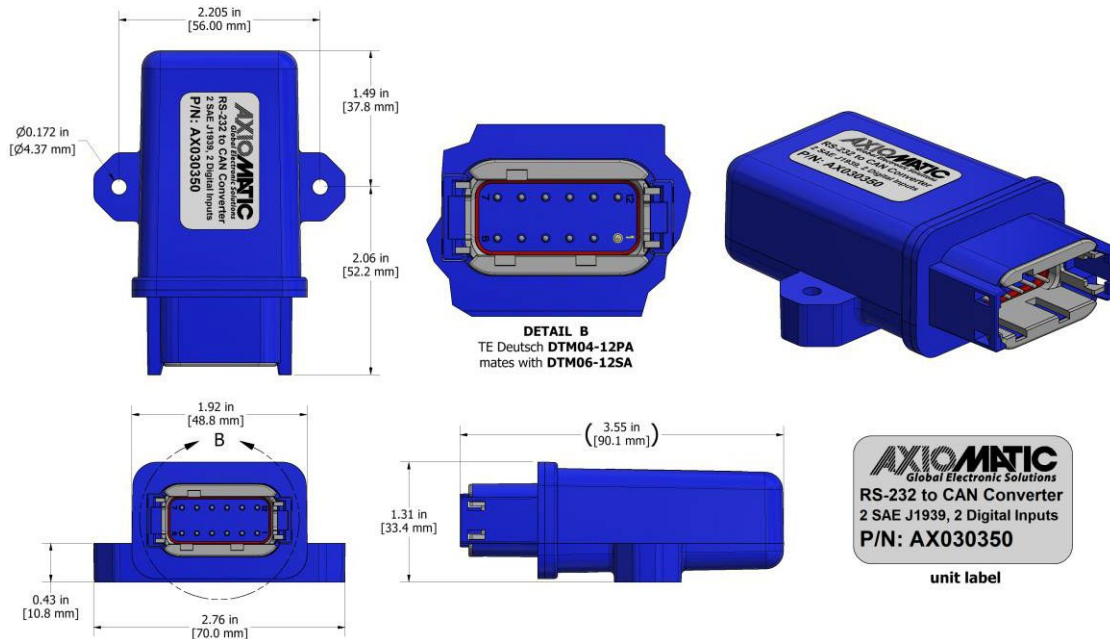

Note: CANopen® is a registered community trademark of CAN in Automation e.V.

Form: TDAX030350-07/11/22