

**11:9 CAN CONTROLLER**

11 Inputs (Analog, Digital, Magnetic Pick Up, Universal Signal)  
 4 Relay, 4 Analog, 1 Valve Driver Outputs  
 2 CAN (SAE J1939)  
 with Electronic Assistant

**P/N: AX031200**

**Features:**

- 12V or 24Vdc nominal input power with surge and transient protection
- Reverse polarity, overvoltage, undervoltage and short circuit protections
- Input and output isolation
- 4 Isolated Analog (0-5V, 0-10V, 4-20 mA or 0-20 mA) or Digital inputs
- 2 Isolated Digital Inputs
- 1 Magnetic Pick-Up Input (0.5 Hz to 10 kHz, 100 mV to 100 Vrms)
- 4 Universal Inputs (0-1V, 0-2.5V, 0-5V, 0-10V Voltage; 4-20 mA, 0-20 mA Current; 30Ω to 250 kΩ Resistive; 0.5 Hz to 10 kHz Frequency; RPM; PWM; or Digital)
- 4 Isolated Analog Outputs (0-5V or 0-10V Voltage; or 4-20 mA, 0-20 mA Current)
- 4 Relay Outputs (Max. 5A, 250VAC or 220VDC, NO)
- 1 Output (2A) to drive a proportional or ON/OFF hydraulic valve
- 2 SAE J1939 CAN bus ports
- -40 to +85 °C operating temperature
- EMC compliance, CE marking
- 48 pin TE Deutsch housing and connectors
- IP67 rating, Suitable for moist and vibrating environments
- Configurable with Electronic Assistant



**Applications:**

- Power Gen Set Engine Control Systems
- Oil and Gas Equipment Automation
- Off-highway Machine Automation

**Ordering Part Numbers:**

SAE J1939 Controller:

Model P/N	Baud Rate	Standard Reference
AX031200	Auto-Baud-Rate Detection	J1939

Mating Plug Kit: **AX070123**

Electronic Assistant: **AX070502** or **AX070505K**

# Technical Specifications:

## Block Diagram

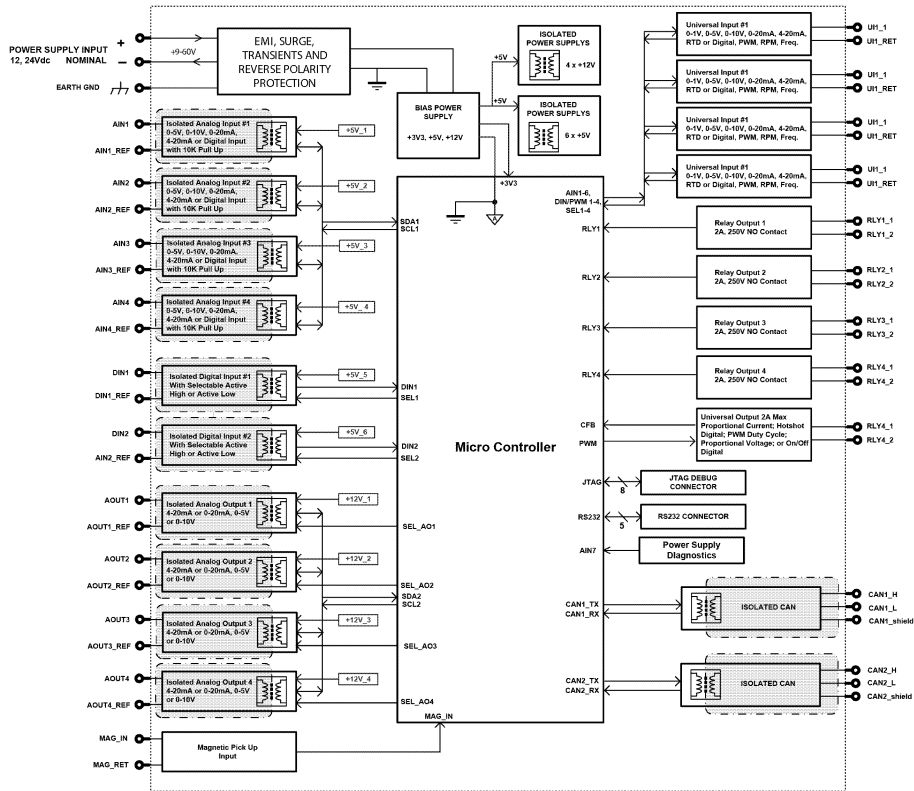

## User Interface

The controller belongs to a family of Axiomatic smart controllers with configurable internal architecture. This provides users with flexibility, allowing them to build their own custom controller with a required functionality from a set of predefined internal functional blocks using the PC-based Axiomatic Electronic Assistant software tool. Application programming is performed through the CAN interface, without disconnecting the controller from the user's system.

## Inputs

Power Supply Input	12 Vdc or 24 Vdc nominal (9...60 Vdc power supply range) Shutdown voltage is 7.5 Vdc.
Protection	Surge and transient protection Reverse polarity protection Overvoltage protection is up to 80 V.
Inputs	11 Inputs, user selectable: 4 Isolated Analog Inputs 2 Isolated Digital Inputs 1 Magnetic Pick Up Input 4 Universal Inputs Refer to Table 1.0. Inputs and Power are isolated from the outputs and CAN.
Input Grounds	Provided

<b>Table 1.0 – Inputs – User Programmable Options</b>	
<b>Analog Inputs</b>	Four fully isolated inputs selectable as : Voltage, Current or Digital types 12-bit Analog to Digital (voltage, current) Inputs are sampled every 1 msec. Protected against shorts to GND or +Vcc
Voltage Type	0-5 V (Impedance 200 KOhm) 0-10 V (Impedance 150 KOhm) 1mV resolution, accuracy +/- 1% error
Current Type	0-20 mA (Impedance 125 Ohm) 4-20 mA (Impedance 125 Ohm) 6 uA resolution, accuracy +/- 1% error Current sense resistor 124Ω
Digital Type	Active High or Active Low
<b>Digital Input</b>	Two fully isolated Active High or Active Low Inputs Configurable 10kΩ pullup or pulldown resistor Pullup at 5VDC, pulldown to reference.
<b>Magnetic Pick-Up Input</b>	One input Range: 0.5 Hz to 10 kHz 100mV to 100V RMS
<b>Universal Inputs</b>	Four fully independent inputs selectable as : Voltage; Current; Resistive; Frequency; RPM; PWM; or Digital types 12-bit Analog to Digital (voltage, current, resistive) 15-bit Timer (frequency, RPM, PWM) Protected against shorts to GND or +Vcc
Voltage Type	0-1V, 0-2.5V, 0--5V or 0-10V 1mV resolution, accuracy +/- 1% error
Current Type	0-20mA or 4-20mA 1uA resolution, accuracy +/- 2% error Current sense resistor 124Ω
Resistive Type	Self-calibrating for range of 30 Ω to 250 kΩ 1Ω resolution, accuracy +/- 1% error
PWM Input	1MΩ Impedance 0 to 100% 100 Hz to 10 kHz 0.01% resolution, accuracy +/- 1% error
Frequency/RPM Input	0.5 Hz to 50 Hz; 0.01 Hz resolution 10 Hz to 1 kHz; 0.1Hz resolution 100 Hz to 10 kHz; 1 Hz resolution Accuracy +/- 1% error
Digital Input	Active High or Active Low with 22 kOhm pull-up or pull-down rated up to 42V

## Outputs

Outputs	<p>4 Isolated Analog Outputs 4 Relay Outputs 1 Valve Driver Output</p> <p>The outputs are user selectable as follows. Refer to Table 2.0.</p> <table border="1" data-bbox="548 352 1334 1333"> <thead> <tr> <th colspan="2">Table 2.0: Outputs</th> </tr> </thead> <tbody> <tr> <td data-bbox="548 380 776 787">Analog Outputs:</td> <td data-bbox="776 380 1334 787"> <p>Four fully isolated analog outputs as : Voltage or Current 12-bit Digital to Analog (voltage, current) Protected against shorts to GND or +Vcc</p> <p><u>Voltage Output:</u> 0-5 Vdc or 0-10 Vdc 1mV resolution, accuracy +/- 1% error</p> <table border="1" data-bbox="813 577 1297 655"> <thead> <tr> <th>Output Range</th> <th>Maximum load</th> </tr> </thead> <tbody> <tr> <td>0-5V</td> <td>1kΩ</td> </tr> <tr> <td>0-10V</td> <td>10kΩ</td> </tr> </tbody> </table> <p><u>Current Output:</u> 0-20 mA or 4-20 mA Max. load resistance is &lt; 350 Ohms Compliance Voltage is 7 V. 6.1 uA resolution, accuracy +/- 1% error</p> </td> </tr> <tr> <td data-bbox="548 787 776 840">Relay Outputs</td> <td data-bbox="776 787 1334 840"> <p>Four Relay Outputs Max. 5A, 250VAC or 220VDC, NO</p> </td> </tr> <tr> <td data-bbox="548 840 776 1333">Valve Driver Output</td> <td data-bbox="776 840 1334 1333"> <p>One fully independent software controlled output selectable as:</p> <ul style="list-style-type: none"> <li>• Proportional Current;</li> <li>• Hotshot Digital;</li> <li>• PWM Duty Cycle;</li> <li>• Proportional Voltage;</li> <li>• or On/Off Digital</li> </ul> <p>Half-bridge output, current sensing, grounded load. High side sourcing up to 2A</p> <p>Current Outputs: 1mA resolution, accuracy +/- 2% error</p> <p>Voltage Outputs: 0.1V resolution, accuracy +/- 5% error Average output based on unit power supply High frequency drive at 25kHz</p> <p>PWM Outputs: 0.1% resolution, accuracy +/- 0.1% error</p> <p>Digital On/Off: Load at supply voltage must not draw more than 2A.</p> </td> </tr> </tbody> </table>	Table 2.0: Outputs		Analog Outputs:	<p>Four fully isolated analog outputs as : Voltage or Current 12-bit Digital to Analog (voltage, current) Protected against shorts to GND or +Vcc</p> <p><u>Voltage Output:</u> 0-5 Vdc or 0-10 Vdc 1mV resolution, accuracy +/- 1% error</p> <table border="1" data-bbox="813 577 1297 655"> <thead> <tr> <th>Output Range</th> <th>Maximum load</th> </tr> </thead> <tbody> <tr> <td>0-5V</td> <td>1kΩ</td> </tr> <tr> <td>0-10V</td> <td>10kΩ</td> </tr> </tbody> </table> <p><u>Current Output:</u> 0-20 mA or 4-20 mA Max. load resistance is &lt; 350 Ohms Compliance Voltage is 7 V. 6.1 uA resolution, accuracy +/- 1% error</p>	Output Range	Maximum load	0-5V	1kΩ	0-10V	10kΩ	Relay Outputs	<p>Four Relay Outputs Max. 5A, 250VAC or 220VDC, NO</p>	Valve Driver Output	<p>One fully independent software controlled output selectable as:</p> <ul style="list-style-type: none"> <li>• Proportional Current;</li> <li>• Hotshot Digital;</li> <li>• PWM Duty Cycle;</li> <li>• Proportional Voltage;</li> <li>• or On/Off Digital</li> </ul> <p>Half-bridge output, current sensing, grounded load. High side sourcing up to 2A</p> <p>Current Outputs: 1mA resolution, accuracy +/- 2% error</p> <p>Voltage Outputs: 0.1V resolution, accuracy +/- 5% error Average output based on unit power supply High frequency drive at 25kHz</p> <p>PWM Outputs: 0.1% resolution, accuracy +/- 0.1% error</p> <p>Digital On/Off: Load at supply voltage must not draw more than 2A.</p>
Table 2.0: Outputs															
Analog Outputs:	<p>Four fully isolated analog outputs as : Voltage or Current 12-bit Digital to Analog (voltage, current) Protected against shorts to GND or +Vcc</p> <p><u>Voltage Output:</u> 0-5 Vdc or 0-10 Vdc 1mV resolution, accuracy +/- 1% error</p> <table border="1" data-bbox="813 577 1297 655"> <thead> <tr> <th>Output Range</th> <th>Maximum load</th> </tr> </thead> <tbody> <tr> <td>0-5V</td> <td>1kΩ</td> </tr> <tr> <td>0-10V</td> <td>10kΩ</td> </tr> </tbody> </table> <p><u>Current Output:</u> 0-20 mA or 4-20 mA Max. load resistance is &lt; 350 Ohms Compliance Voltage is 7 V. 6.1 uA resolution, accuracy +/- 1% error</p>	Output Range	Maximum load	0-5V	1kΩ	0-10V	10kΩ								
Output Range	Maximum load														
0-5V	1kΩ														
0-10V	10kΩ														
Relay Outputs	<p>Four Relay Outputs Max. 5A, 250VAC or 220VDC, NO</p>														
Valve Driver Output	<p>One fully independent software controlled output selectable as:</p> <ul style="list-style-type: none"> <li>• Proportional Current;</li> <li>• Hotshot Digital;</li> <li>• PWM Duty Cycle;</li> <li>• Proportional Voltage;</li> <li>• or On/Off Digital</li> </ul> <p>Half-bridge output, current sensing, grounded load. High side sourcing up to 2A</p> <p>Current Outputs: 1mA resolution, accuracy +/- 2% error</p> <p>Voltage Outputs: 0.1V resolution, accuracy +/- 5% error Average output based on unit power supply High frequency drive at 25kHz</p> <p>PWM Outputs: 0.1% resolution, accuracy +/- 0.1% error</p> <p>Digital On/Off: Load at supply voltage must not draw more than 2A.</p>														
Isolation	<p>300 Vrms The outputs are isolated from the inputs. The CAN bus port is isolated from both inputs and outputs.</p>														
Protection for Output Terminals	<p>Fully protected against short circuit to output ground and +Vcc. Unit will fail safe in the case of a short circuit condition, self-recovering when the short is removed.</p>														

## General Specifications

Microprocessor	STM32H723ZGT6, 32-bit, 1 Mbyte flash memory, 564 Kbytes SRAM
Typical Quiescent Current	97 mA @ 24Vdc
Control Logic	<p>Standard embedded software is provided. (Application-specific control logic or factory programmed set point file on request)</p>
Communications	2 Isolated CAN ports (SAE J1939) (A CANopen® model is available as P/N: AX031201.)
Baud Rate	CAN Baud rate: 250, 500, 667 kbit/s, 1 Mbit/s. Automatic baud rate detection.
Network Termination	<p>It is necessary to terminate the network with external termination resistors. The resistors are 120 Ohm, 0.25W minimum, metal film or similar type. They should be placed between CAN_H and CAN_L terminals at both ends of the network.</p>

User Interface	Control setpoints can be viewed and programmed using the standard J1939 memory access protocol through the CAN port and the PC-based Axiomatic Electronic Assistant. The EA can store all setpoints in one setpoint file and then flash them into the unit in one operation. The setpoint file is created and stored on disk using a command <i>Save Setpoint File</i> from the EA menu or toolbar. The user then can open the setpoint file, view or print it and flash the setpoint file into the controller.  The Electronic Assistant®, P/N: <b>AX070502</b> , for <i>Windows</i> operating systems comes with a royalty-free license for use on multiple computers. It includes an Axiomatic USB-CAN converter to link the device's CAN port to a <i>Windows</i> -based PC.
EMC Compliance	CE marking
Vibration	Random Vibration: 7.68 Grms peak Sinusoidal Component: 10 g peak Based on MIL-STD-202G, Methods 204G, 214A and 213B
Operating Conditions	-40 to 85 °C (-40 to 185 °F)
Storage Temperature	-55 to 125 °C (-67 to 257 °F)
Protection	IP67
Weight	1.35 lbs. (0.612 kg)
Enclosure	High Temperature Nylon housing, TE Deutsch P/N: EEC-5X650B 5.67 x 7.92 x 2.15 inches (144.0 x 201.3 x 54.6 mm) L x W x H including integral connector Refer to the dimensional drawing.
Installation	For mounting information, refer to the dimensional drawing.  Mounting holes sized for ¼ inch or M6 bolts. The bolt length will be determined by the end-user's mounting plate thickness. The mounting flange of the controller is 0.25 inches (6.35 mm) thick. If the module is mounted without an enclosure, it should be mounted to reduce the likelihood of moisture entry. Install the unit with appropriate space available for servicing and for adequate wire harness access (6 inches or 15 cm) and strain relief (12 inches or 30 cm). Wires should be of the appropriate gauge to meet requirements of applicable electrical codes and suit the specifications of the connector.  The module must be mounted in an enclosure in hazardous locations. All field wiring should be suitable for the operating temperature range of the module. All chassis grounding should go to a single ground point designated for the machine and all related equipment.

### Dimensional Drawing

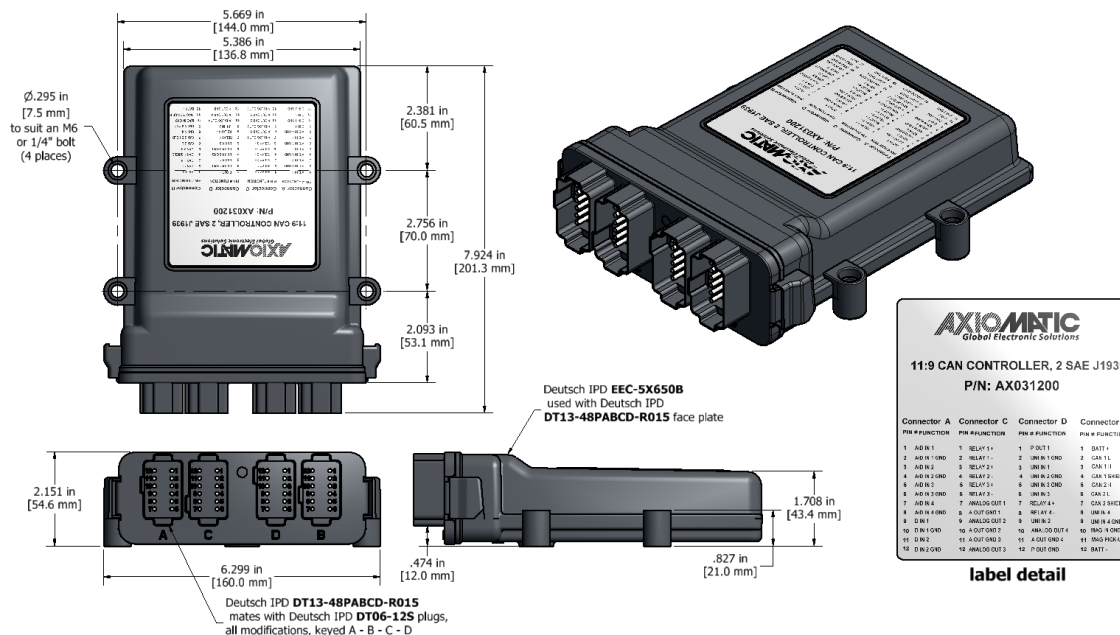

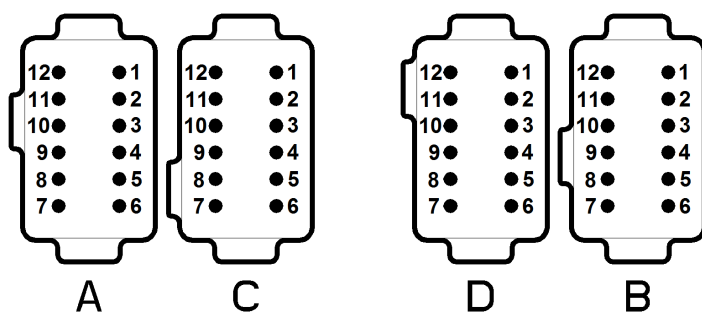
Electrical Connections	<p>48 pin TE Deutsch Connector (P/N: DT13-48PABCD-R015) or 48 pin Amphenol Face Plate Connector (P/N: ATM13-12PA-12PB-BM03), based on availability.</p>  <p>Table 3 - Electrical Pin Out</p> <table border="1" data-bbox="548 682 1347 1108"> <thead> <tr> <th colspan="2">Connector A</th> <th colspan="2">Connector C</th> <th colspan="2">Connector D</th> <th colspan="2">Connector B</th> </tr> <tr> <th>Pin #</th> <th>Function</th> <th>Pin #</th> <th>Function</th> <th>Pin #</th> <th>Function</th> <th>Pin #</th> <th>Function</th> </tr> </thead> <tbody> <tr> <td>1</td> <td>A/D IN 1</td> <td>1</td> <td>RELAY 1 +</td> <td>1</td> <td>P OUT</td> <td>1</td> <td>BATT +</td> </tr> <tr> <td>2</td> <td>A/D IN 1 GND</td> <td>2</td> <td>RELAY 1 -</td> <td>2</td> <td>UNI IN 1 RTN</td> <td>2</td> <td>CAN 1 L</td> </tr> <tr> <td>3</td> <td>A/D IN 2</td> <td>3</td> <td>RELAY 2 +</td> <td>3</td> <td>UNI IN 1</td> <td>3</td> <td>CAN 1 H</td> </tr> <tr> <td>4</td> <td>A/D IN 2 GND</td> <td>4</td> <td>RELAY 2 -</td> <td>4</td> <td>UNI IN 2 RTN</td> <td>4</td> <td>CAN 1 SH</td> </tr> <tr> <td>5</td> <td>A/D IN 3</td> <td>5</td> <td>RELAY 3 +</td> <td>5</td> <td>UNI IN 3 RTN</td> <td>5</td> <td>CAN 2 H</td> </tr> <tr> <td>6</td> <td>A/D IN 3 GND</td> <td>6</td> <td>RELAY 3 -</td> <td>6</td> <td>UNI IN 3</td> <td>6</td> <td>CAN 2 L</td> </tr> <tr> <td>7</td> <td>A/D IN 4</td> <td>7</td> <td>A OUT 1</td> <td>7</td> <td>RELAY 4 +</td> <td>7</td> <td>CAN 2 SH</td> </tr> <tr> <td>8</td> <td>A/D IN 4 GND</td> <td>8</td> <td>A OUT GND 1</td> <td>8</td> <td>RELAY 4 -</td> <td>8</td> <td>UNI IN 4</td> </tr> <tr> <td>9</td> <td>D IN 1</td> <td>9</td> <td>A OUT 2</td> <td>9</td> <td>UNI IN 2</td> <td>9</td> <td>UNI IN 4 RTN</td> </tr> <tr> <td>10</td> <td>D IN 1 GND</td> <td>10</td> <td>A OUT GND 2</td> <td>10</td> <td>A OUT 4</td> <td>10</td> <td>MAG IN GND</td> </tr> <tr> <td>11</td> <td>D IN 2</td> <td>11</td> <td>A OUT GND 3</td> <td>11</td> <td>A OUT GND 4</td> <td>11</td> <td>MAG PICK- UP IN</td> </tr> <tr> <td>12</td> <td>D IN 2 GND</td> <td>12</td> <td>A OUT 3</td> <td>12</td> <td>P OUT GND</td> <td>12</td> <td>BATT -</td> </tr> </tbody> </table>	Connector A		Connector C		Connector D		Connector B		Pin #	Function	Pin #	Function	Pin #	Function	Pin #	Function	1	A/D IN 1	1	RELAY 1 +	1	P OUT	1	BATT +	2	A/D IN 1 GND	2	RELAY 1 -	2	UNI IN 1 RTN	2	CAN 1 L	3	A/D IN 2	3	RELAY 2 +	3	UNI IN 1	3	CAN 1 H	4	A/D IN 2 GND	4	RELAY 2 -	4	UNI IN 2 RTN	4	CAN 1 SH	5	A/D IN 3	5	RELAY 3 +	5	UNI IN 3 RTN	5	CAN 2 H	6	A/D IN 3 GND	6	RELAY 3 -	6	UNI IN 3	6	CAN 2 L	7	A/D IN 4	7	A OUT 1	7	RELAY 4 +	7	CAN 2 SH	8	A/D IN 4 GND	8	A OUT GND 1	8	RELAY 4 -	8	UNI IN 4	9	D IN 1	9	A OUT 2	9	UNI IN 2	9	UNI IN 4 RTN	10	D IN 1 GND	10	A OUT GND 2	10	A OUT 4	10	MAG IN GND	11	D IN 2	11	A OUT GND 3	11	A OUT GND 4	11	MAG PICK- UP IN	12	D IN 2 GND	12	A OUT 3	12	P OUT GND	12	BATT -
Connector A		Connector C		Connector D		Connector B																																																																																																											
Pin #	Function	Pin #	Function	Pin #	Function	Pin #	Function																																																																																																										
1	A/D IN 1	1	RELAY 1 +	1	P OUT	1	BATT +																																																																																																										
2	A/D IN 1 GND	2	RELAY 1 -	2	UNI IN 1 RTN	2	CAN 1 L																																																																																																										
3	A/D IN 2	3	RELAY 2 +	3	UNI IN 1	3	CAN 1 H																																																																																																										
4	A/D IN 2 GND	4	RELAY 2 -	4	UNI IN 2 RTN	4	CAN 1 SH																																																																																																										
5	A/D IN 3	5	RELAY 3 +	5	UNI IN 3 RTN	5	CAN 2 H																																																																																																										
6	A/D IN 3 GND	6	RELAY 3 -	6	UNI IN 3	6	CAN 2 L																																																																																																										
7	A/D IN 4	7	A OUT 1	7	RELAY 4 +	7	CAN 2 SH																																																																																																										
8	A/D IN 4 GND	8	A OUT GND 1	8	RELAY 4 -	8	UNI IN 4																																																																																																										
9	D IN 1	9	A OUT 2	9	UNI IN 2	9	UNI IN 4 RTN																																																																																																										
10	D IN 1 GND	10	A OUT GND 2	10	A OUT 4	10	MAG IN GND																																																																																																										
11	D IN 2	11	A OUT GND 3	11	A OUT GND 4	11	MAG PICK- UP IN																																																																																																										
12	D IN 2 GND	12	A OUT 3	12	P OUT GND	12	BATT -																																																																																																										
Mating Plugs	<p>Mates with the following TE Deutsch P/N's:  DT06-12SA Plug, DT 12 Way A Key  DT06-12SB Plug, DT 12 Way B Key  DT06-12SC Plug, DT 12 Way C Key  DT06-12SD Plug, DT 12 Way D Key  A set of these mating plugs is available (P/N: AX070123).</p>																																																																																																																

Notes:

CANopen® is a registered community trademark of CAN in Automation e.V.

Specifications are indicative and subject to change. Actual performance will vary depending on the application and operating conditions. Users should satisfy themselves that the product is suitable for use in the intended application. All our products carry a limited warranty against defects in material and workmanship. Please refer to our Warranty, Application Approvals/Limitations and Return Materials Process as described on <https://www.axiomatic.com/service/>.

TDAX031200-07/27/22