

2 Bipolar, 8 Universal Signal Inputs Controller

CAN (SAE J1939)

Ethernet (Modbus TCP/IP) in Model AX032100 only

Two +5V references

DIN rail mount

P/N: AX032100, AX032120

Features:

- SAE J1939 CAN port with auto-baud-rate detection
- Ethernet port (Modbus TCP/IP)
- Two (2) signal inputs are selectable as bipolar voltage, current, digital or PWM signal types:
 - 0-5V, 0-10V, 0 to +/- 5V, 0 to +/- 10V;
 - 4-20mA, 0-20mA;
 - PWM, Frequency;
 - or Digital (Discrete Voltage Level).
- Eight (8) universal signal inputs are selectable as bipolar voltage, current, resistive, digital, PWM or frequency signal types:
 - 0-5V, 0-10V;
 - 4-20mA, 0-20mA;
 - Resistive
 - PWM;
 - Frequency;
 - or Digital.
- 12Vdc or 24Vdc nominal
- Two reference voltages (+5V) are available.
- Operates from -40 to 85°C (-40 to 185°F).
- Two LED indicators
- IP20
- DIN rail mount, screw terminal connections
- Configurable via Electronic Assistant



Applications:

- industrial control panels
- power gen set engine control systems
- oil and gas equipment automation
- machine automation

Ordering Part Numbers:

2 Bipolar A/D and 8 Universal Signal Inputs Controller, Modbus TCP/IP, SAE J1939 auto-baud-rate detection: **AX032100**

2 Bipolar A/D and 8 Universal Signal Inputs Controller, SAE J1939 auto-baud-rate detection: **AX032120**

2 Bipolar A/D and 8 Universal Signal Inputs Controller, Modbus TCP/IP, CANopen®: **AX032101**

2 Bipolar A/D and 8 Universal Signal Inputs Controller, CANopen®: **AX032121**

Accessories:

Electronic Assistant: **AX070502**

Description: The Controller accepts two analog/digital signal inputs and eight universal signal inputs. The control can be networked to a SAE J1939 or a Modbus TCP/IP fieldbus (in Model AX032100). Two +5V, 100 mA references are available to power sensor inputs. A rugged power supply interface accepts 12 Vdc or 24 Vdc nominal for battery powered machine applications. LED's indicate operational status. The enclosure is DIN rail mount. It operates from -40 to 85°C (-40 to 185°F). Standard embedded software is provided and is configurable using the Electronic Assistant (EA). The sophisticated control algorithms allow the user to program the controller for a wide range of applications without the need for custom software.

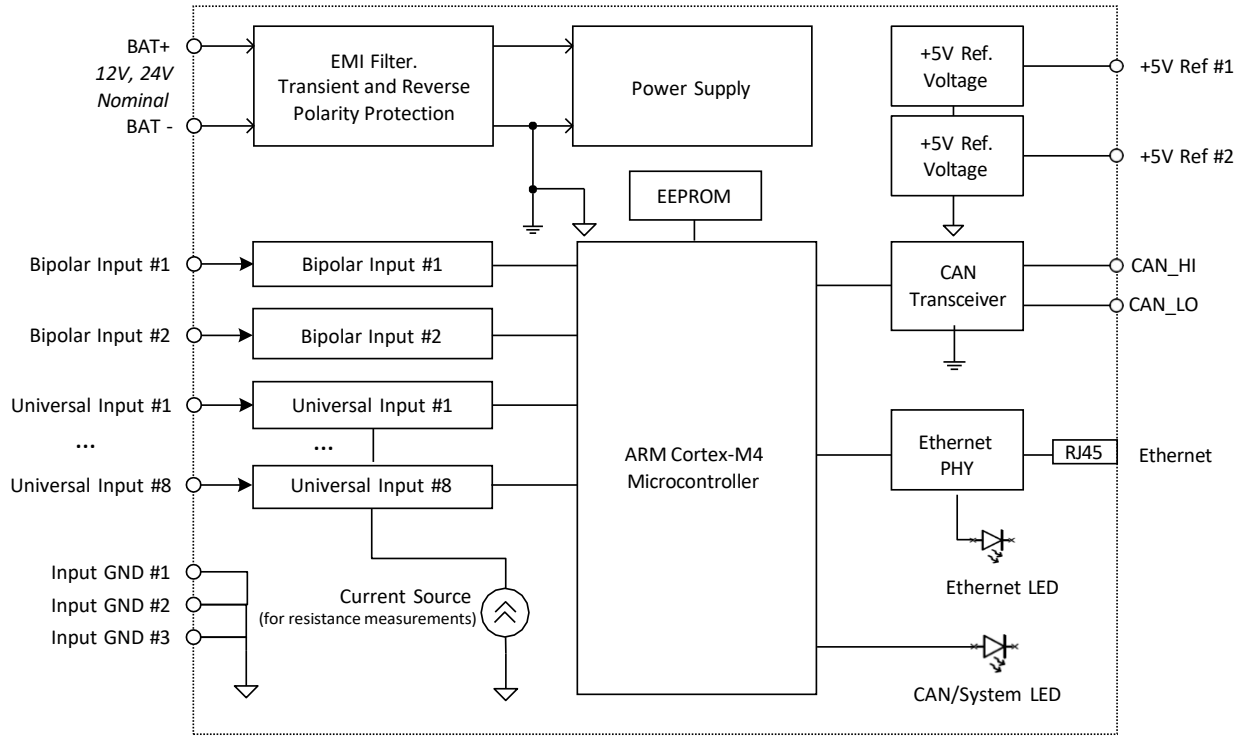

Figure 1.0 – Block Diagram

Technical Specifications:

Specifications are indicative and subject to change. Actual performance will vary depending on the application and operating conditions. Users should satisfy themselves that the product is suitable for use in the intended application. All our products carry a limited warranty against defects in material and workmanship. Please refer to our Warranty, Application Approvals/Limitations and Return Materials Process as described on <https://www.axiomatic.com/service/>.

Power Supply

| | |
|--------------------|---|
| Power Supply Input | 12 Vdc or 24 Vdc nominal 8...36 Vdc power supply range |
| Protections | Reverse polarity protection Transient protection Short circuit to Ground protection |

Bipolar Inputs

| | |
|---------------|---|
| Inputs | 2 Bipolar Analog or Digital Signal Inputs User programmable as Bipolar or Unipolar Voltage, Current, PWM or Digital signal input types. Refer to Table 1.0. |
| Input Grounds | 1 provided |
| Protection | All inputs are protected against short to GND. All inputs, except current inputs, are protected against shorts to Nominal Vps (36Vdc). |

| Table 1.0 –User Programmable Bipolar and Analog Inputs | | | | | | | | | | | | | | | | | | | | | | | | | | |
|--|--|--------------------|-----------------|------------------------|----------|------------|-------------|----------|------------|---------|------|----------|---------|-------|----------|-------|-----------|----------|-------|-------------|----------|-------|---------|-----------|----------|-------------|
| Analog Input Functions | Voltage Input, Current Input | | | | | | | | | | | | | | | | | | | | | | | | | |
| Voltage Input | 0-5 V (Impedance 1M Ω) 0-10 V (Impedance 1M Ω) +/- 5V (Impedance 1M Ω) +/- 10V (Impedance 1M Ω) | | | | | | | | | | | | | | | | | | | | | | | | | |
| Current Input | 0-20 mA (Impedance 124 Ω) 4-20 mA (Impedance 124 Ω) | | | | | | | | | | | | | | | | | | | | | | | | | |
| Analog Update Rate | 1.67 ms depending on analog filter settings | | | | | | | | | | | | | | | | | | | | | | | | | |
| Input Accuracy and Resolution | <table border="1"> <thead> <tr> <th>Input Type</th> <th>Input Range</th> <th>Accuracy</th> <th>Resolution</th> </tr> </thead> <tbody> <tr> <td rowspan="4">Voltage</td> <td>0-5V</td> <td>+/- TBD%</td> <td><1.5 mV</td> </tr> <tr> <td>0-10V</td> <td>+/- TBD%</td> <td><3 mV</td> </tr> <tr> <td>-5V to 5V</td> <td>+/- TBD%</td> <td><3 mV</td> </tr> <tr> <td>-10V to 10V</td> <td>+/- TBD%</td> <td><6 mV</td> </tr> <tr> <td>Current</td> <td>0(4)-20mA</td> <td>+/- TBD%</td> <td><12 μA</td> </tr> </tbody> </table> | | | | | Input Type | Input Range | Accuracy | Resolution | Voltage | 0-5V | +/- TBD% | <1.5 mV | 0-10V | +/- TBD% | <3 mV | -5V to 5V | +/- TBD% | <3 mV | -10V to 10V | +/- TBD% | <6 mV | Current | 0(4)-20mA | +/- TBD% | <12 μ A |
| Input Type | Input Range | Accuracy | Resolution | | | | | | | | | | | | | | | | | | | | | | | |
| Voltage | 0-5V | +/- TBD% | <1.5 mV | | | | | | | | | | | | | | | | | | | | | | | |
| | 0-10V | +/- TBD% | <3 mV | | | | | | | | | | | | | | | | | | | | | | | |
| | -5V to 5V | +/- TBD% | <3 mV | | | | | | | | | | | | | | | | | | | | | | | |
| | -10V to 10V | +/- TBD% | <6 mV | | | | | | | | | | | | | | | | | | | | | | | |
| Current | 0(4)-20mA | +/- TBD% | <12 μ A | | | | | | | | | | | | | | | | | | | | | | | |
| Digital Input Functions | Discrete Voltage Level, PWM Duty Cycle Input, Frequency Input | | | | | | | | | | | | | | | | | | | | | | | | | |
| Input Polarity | Active High or Active Low | | | | | | | | | | | | | | | | | | | | | | | | | |
| Input Impedance | 1 M Ω Impedance – High Z, 10 kOhm pull-down, 10 kOhm pull-up to +14V | | | | | | | | | | | | | | | | | | | | | | | | | |
| Input Level | 5V CMOS compatible A direct connection to the power supply is acceptable. | | | | | | | | | | | | | | | | | | | | | | | | | |
| Discrete Voltage Level Input | 1 ms sampling rate Configurable debouncing | | | | | | | | | | | | | | | | | | | | | | | | | |
| Frequency Input | Input Number | Counter Resolution | Frequency Range | Resolution | Accuracy | | | | | | | | | | | | | | | | | | | | | |
| | Bipolar Input #1 | 32-bit | 1Hz...10kHz | <0.000012... 0.012% | <0.01% | | | | | | | | | | | | | | | | | | | | | |
| | Bipolar Input #2 | 16-bit | 100Hz...10kHz | <0.0017... 0.17% | | | | | | | | | | | | | | | | | | | | | | |
| | | | 10Hz...1kHz | | | | | | | | | | | | | | | | | | | | | | | |
| | | | 1Hz...100Hz | | | | | | | | | | | | | | | | | | | | | | | |
| PWM Input | Input Number | Counter Resolution | Frequency Range | Resolution | Accuracy | | | | | | | | | | | | | | | | | | | | | |
| | Bipolar Input #1 | 32-bit | 1Hz...10kHz | <0.000012... 0.012% | TBD | | | | | | | | | | | | | | | | | | | | | |
| | Bipolar Input #2 | 16-bit | 100Hz...10kHz | <0.0017... 0.17% | | | | | | | | | | | | | | | | | | | | | | |
| | | | 10Hz...1kHz | | | | | | | | | | | | | | | | | | | | | | | |
| | | | 1Hz...100Hz | | | | | | | | | | | | | | | | | | | | | | | |
| PWM Duty Cycle | 0...100% Duty Cycle | | | | | | | | | | | | | | | | | | | | | | | | | |
| Protection | +/- 36V maximum Forward and reverse polarity protection | | | | | | | | | | | | | | | | | | | | | | | | | |

Universal Inputs

| Inputs | 8 Universal Signal Inputs User programmable as Voltage, Current, Resistive, Frequency, PWM or Digital signal input types. Refer to Table 2.0. | | | | | | | | | | | | | | | | | | | | | | |
|--|--|-----------------|---------------------|----------|--|--------------|--------------------|-----------------|---|----------|----------------------|-------------------------|---------------|---------------------|-------------|-------------|-------------|------------|----------|-------------|-------------|----------|-----|
| Table 2.0 –User Programmable Universal Inputs | | | | | | | | | | | | | | | | | | | | | | | |
| Analog Input Functions | Voltage Input, Current Input, Resistive Input | | | | | | | | | | | | | | | | | | | | | | |
| Voltage Input | 0-5 V (Impedance 1M Ω (High Z)) 0-10 V (Impedance 204 k Ω) | | | | | | | | | | | | | | | | | | | | | | |
| Current Input | 0-20 mA (Impedance 249 Ω) 4-20 mA (Impedance 249 Ω) | | | | | | | | | | | | | | | | | | | | | | |
| Input Accuracy and Resolution | <table border="1"> <thead> <tr> <th>Input Type</th> <th>Input Range</th> <th>Accuracy</th> <th>Resolution</th> </tr> </thead> <tbody> <tr> <td rowspan="2">Voltage</td> <td>0-5V</td> <td>+/- TBD%</td> <td><1.5 mV</td> </tr> <tr> <td>0-10V</td> <td>+/- TBD%</td> <td><3 mV</td> </tr> <tr> <td>Current</td> <td>0(4)-20mA</td> <td>+/- TBD%</td> <td><12 μA</td> </tr> </tbody> </table> | | | | | Input Type | Input Range | Accuracy | Resolution | Voltage | 0-5V | +/- TBD% | <1.5 mV | 0-10V | +/- TBD% | <3 mV | Current | 0(4)-20mA | +/- TBD% | <12 μ A | | | |
| Input Type | Input Range | Accuracy | Resolution | | | | | | | | | | | | | | | | | | | | |
| Voltage | 0-5V | +/- TBD% | <1.5 mV | | | | | | | | | | | | | | | | | | | | |
| | 0-10V | +/- TBD% | <3 mV | | | | | | | | | | | | | | | | | | | | |
| Current | 0(4)-20mA | +/- TBD% | <12 μ A | | | | | | | | | | | | | | | | | | | | |
| Resistive Input | <table border="1"> <thead> <tr> <th>Input Range</th> <th>Resolution</th> <th>Accuracy</th> </tr> </thead> <tbody> <tr> <td>Auto Range 10...250kOhm^{1,2}</td> <td>–</td> <td>–</td> </tr> <tr> <td>0...250Ohm²</td> <td><0.15 Ohm</td> <td>TBD</td> </tr> <tr> <td>0...2.5kOhm</td> <td><1.5 Ohm</td> <td>TBD</td> </tr> <tr> <td>0...25kOhm</td> <td><15 Ohm</td> <td>TBD</td> </tr> <tr> <td>0...250kOhm</td> <td><150 Ohm</td> <td>TBD</td> </tr> </tbody> </table> <p>¹ Resolution and accuracy depend on the automatically selected Input Range. ² Resistance <10 Ohm is measured as 0.</p> | | | | | Input Range | Resolution | Accuracy | Auto Range 10...250kOhm ^{1,2} | – | – | 0...250Ohm ² | <0.15 Ohm | TBD | 0...2.5kOhm | <1.5 Ohm | TBD | 0...25kOhm | <15 Ohm | TBD | 0...250kOhm | <150 Ohm | TBD |
| Input Range | Resolution | Accuracy | | | | | | | | | | | | | | | | | | | | | |
| Auto Range 10...250kOhm ^{1,2} | – | – | | | | | | | | | | | | | | | | | | | | | |
| 0...250Ohm ² | <0.15 Ohm | TBD | | | | | | | | | | | | | | | | | | | | | |
| 0...2.5kOhm | <1.5 Ohm | TBD | | | | | | | | | | | | | | | | | | | | | |
| 0...25kOhm | <15 Ohm | TBD | | | | | | | | | | | | | | | | | | | | | |
| 0...250kOhm | <150 Ohm | TBD | | | | | | | | | | | | | | | | | | | | | |
| Analog Update Rate | 1.67 ms depending on analog filter settings In resistive mode, it also depends on the number of resistive inputs. | | | | | | | | | | | | | | | | | | | | | | |
| Digital Input Functions | Discrete Voltage Level, PWM Duty Cycle Input, Frequency Input | | | | | | | | | | | | | | | | | | | | | | |
| Input Polarity | Active High or Active Low | | | | | | | | | | | | | | | | | | | | | | |
| Input Impedance | 1 M Ω Impedance – High Z, 10 kOhm pull-down, 10 kOhm pull-up to +14V | | | | | | | | | | | | | | | | | | | | | | |
| Input Level | 5V CMOS compatible A direct connection to the power supply is acceptable. | | | | | | | | | | | | | | | | | | | | | | |
| Discrete Voltage Level Input | 1 ms sampling rate Configurable debouncing | | | | | | | | | | | | | | | | | | | | | | |
| Frequency Input | <table border="1"> <thead> <tr> <th>Input Number</th> <th>Counter Resolution</th> <th>Frequency Range</th> <th>Resolution</th> <th>Accuracy</th> </tr> </thead> <tbody> <tr> <td rowspan="3">Universal Input #1-8</td> <td rowspan="3">16-bit</td> <td>100Hz...10kHz</td> <td rowspan="3"><0.0017... 0.17%</td> <td rowspan="3"><0.01%</td> </tr> <tr> <td>10Hz...1kHz</td> </tr> <tr> <td>1Hz...100Hz</td> </tr> </tbody> </table> | | | | | Input Number | Counter Resolution | Frequency Range | Resolution | Accuracy | Universal Input #1-8 | 16-bit | 100Hz...10kHz | <0.0017... 0.17% | <0.01% | 10Hz...1kHz | 1Hz...100Hz | | | | | | |
| Input Number | Counter Resolution | Frequency Range | Resolution | Accuracy | | | | | | | | | | | | | | | | | | | |
| Universal Input #1-8 | 16-bit | 100Hz...10kHz | <0.0017... 0.17% | <0.01% | | | | | | | | | | | | | | | | | | | |
| | | 10Hz...1kHz | | | | | | | | | | | | | | | | | | | | | |
| | | 1Hz...100Hz | | | | | | | | | | | | | | | | | | | | | |
| PWM Input | <table border="1"> <thead> <tr> <th>Input Number</th> <th>Counter Resolution</th> <th>Frequency Range</th> <th>Resolution</th> <th>Accuracy</th> </tr> </thead> <tbody> <tr> <td rowspan="3">Universal Input #1-8</td> <td rowspan="3">16-bit</td> <td>100Hz...10kHz</td> <td rowspan="3"><0.0017... 0.17%</td> <td rowspan="3">TBD</td> </tr> <tr> <td>10Hz...1kHz</td> </tr> <tr> <td>1Hz...100Hz</td> </tr> </tbody> </table> | | | | | Input Number | Counter Resolution | Frequency Range | Resolution | Accuracy | Universal Input #1-8 | 16-bit | 100Hz...10kHz | <0.0017... 0.17% | TBD | 10Hz...1kHz | 1Hz...100Hz | | | | | | |
| Input Number | Counter Resolution | Frequency Range | Resolution | Accuracy | | | | | | | | | | | | | | | | | | | |
| Universal Input #1-8 | 16-bit | 100Hz...10kHz | <0.0017... 0.17% | TBD | | | | | | | | | | | | | | | | | | | |
| | | 10Hz...1kHz | | | | | | | | | | | | | | | | | | | | | |
| | | 1Hz...100Hz | | | | | | | | | | | | | | | | | | | | | |
| PWM Duty Cycle | 0...100% Duty Cycle | | | | | | | | | | | | | | | | | | | | | | |
| Protection | +/- 36V maximum Forward and reverse polarity protection | | | | | | | | | | | | | | | | | | | | | | |

Outputs

| | |
|--------------------|--|
| Voltage References | Two +5V, +/- 1%, 100 mA Short circuit protection Connection to the power supply is prohibited. |
|--------------------|--|

General Specifications

| | | | | | | | | | |
|-----------------------------|---|---------------------------|--|------|----------------------------------|--------------|---|-------|---|
| Microprocessor | STM32F407Z, 32-bit, 1MByte flash memory | | | | | | | | |
| Typical Quiescent Current | 100 mA@ 12Vdc; 50 mA @ 24Vdc typical | | | | | | | | |
| LED Indicators | 2 bicolour LED's Red/Green: CAN/System error/CAN link (activity) Flashing: Bootloader mode Yellow/Green: Ethernet speed/link (activity) | | | | | | | | |
| CAN Communications | 1 CAN port (SAE J1939) (Model AX032101 is CANopen®.) Full support for SAE J1939 ECU User-configurable PGN's Baud rate: 250, 500, 667 kbit/s, 1 Mbit/s. Automatic baud rate detection. | | | | | | | | |
| Ethernet | One 10 BASE-T/100 BASE-TX Ethernet port Auto-MDIX Ethernet IEEE 802.3, IP, ICMP, ARP, UDP, TCP, Modbus TCP, Proprietary Discovery Protocol | | | | | | | | |
| Modbus TCP/IP | Model AX032100: Uses Ethernet port Server mode (slave device) Up to 8 simultaneous connections <table border="1" data-bbox="548 762 1279 867"> <tr> <td colspan="2">Supported function codes:</td> </tr> <tr> <td>2, 4</td> <td>Reading bipolar/Universal inputs</td> </tr> <tr> <td>3, 6, 13, 23</td> <td>Reading/changing configuration parameters</td> </tr> <tr> <td>43/14</td> <td>Reading controller ID, S/N on a private object 0x80</td> </tr> </table> Model AX032120: Not present | Supported function codes: | | 2, 4 | Reading bipolar/Universal inputs | 3, 6, 13, 23 | Reading/changing configuration parameters | 43/14 | Reading controller ID, S/N on a private object 0x80 |
| Supported function codes: | | | | | | | | | |
| 2, 4 | Reading bipolar/Universal inputs | | | | | | | | |
| 3, 6, 13, 23 | Reading/changing configuration parameters | | | | | | | | |
| 43/14 | Reading controller ID, S/N on a private object 0x80 | | | | | | | | |
| Control Logic | Refer to the user manual. | | | | | | | | |
| User Interface – via CAN | To configure the controller for sophisticated control applications, the AX032100 setpoints can be viewed and programmed using the standard J1939 memory access protocol through the CAN port and the PC-based Axiomatic Electronic Assistant. The EA can store all setpoints in one setpoint file and then flash them into the unit in one operation. The setpoint file is created and stored on disk using a command <i>Save Setpoint File</i> from the EA menu or toolbar. The user then can open the setpoint file, view or print it and flash the setpoint file into the unit. The Electronic Assistant, P/N: AX070502 , for <i>Windows</i> operating systems comes with a royalty-free license for use on multiple computers. It includes an Axiomatic USB-CAN converter to link the device's CAN port to a <i>Windows</i> -based PC. Refer to the user manual for details. | | | | | | | | |
| User Interface – via Modbus | Modbus TCP - Third-party software | | | | | | | | |
| Software Reflashing | Via J1939 CAN - Electronic Assistant P/N: AX070502 Modbus TCP – not currently supported | | | | | | | | |
| Operating Conditions | -40 to 85 °C (-40 to 185 °F) | | | | | | | | |
| Storage Temperature | -55 to 125 °C (-67 to 257°F) | | | | | | | | |
| Protection | IP20 | | | | | | | | |
| Weight | 0.30 lb. (0.136 kg) | | | | | | | | |
| Enclosure and Dimensions | Phoenix Contact: ME MAX 22,5 G 2-2 KMGY – 2713638 Polyamide, UL94V0, cULus recognized, China RoHS DIN rail TH 35-7.5 114.5 x 22.5 x 99 x 107 mm 4.508 x 0.89 x 3.898 x 4.213 in (L x H x W x D) Refer to Figure 2.0. | | | | | | | | |
| Electrical Connections | 4 sets of 5 Phoenix Contact MC 1,5/ 5-ST-3,5 GY7035 3.5 mm screw terminal connectors Accepts 28-16 AWG wire. RJ-45 for Ethernet connection Refer to Table 3.0 and Figure 2.0. for pin out. | | | | | | | | |
| Installation | DIN rail mount TH 35-7.5 or TH 35-15 (mm) | | | | | | | | |

| | |
|---------------------|---|
| Network Termination | <p>ISO 11898</p> <p>It is necessary to terminate the network with external termination resistors. The resistors are 120 Ohm, 0.25W minimum, metal film or similar type. They should be placed between CAN_H and CAN_L terminals at both ends of the network. Baud rate up to 1 Mbit/s is supported.</p> |
|---------------------|---|

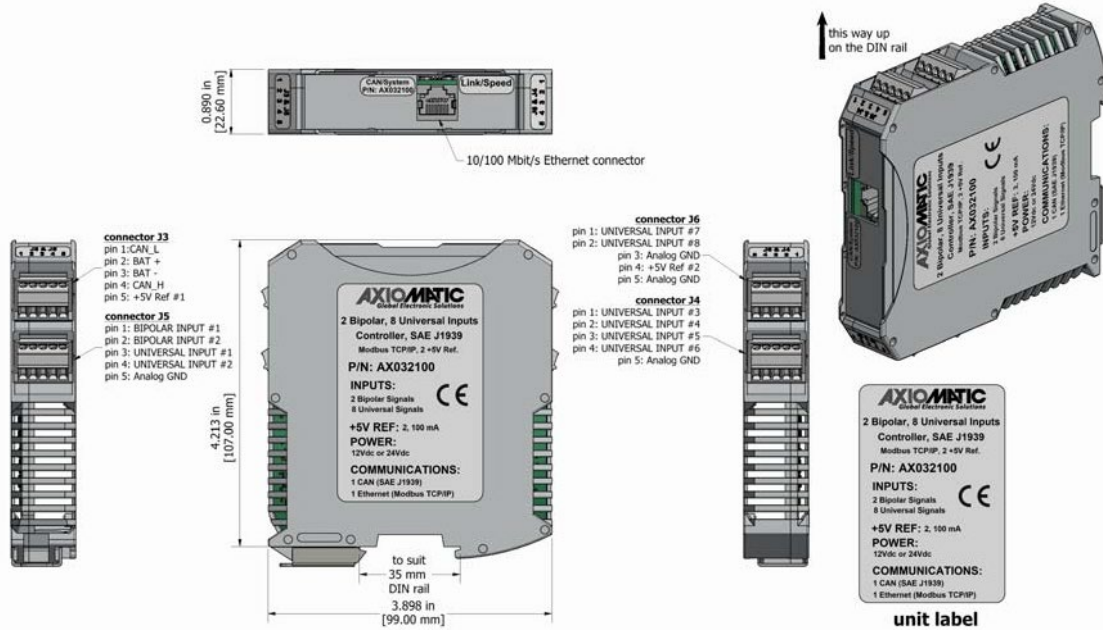

Figure 2.0 – Dimensions of AX032100 (with Ethernet)

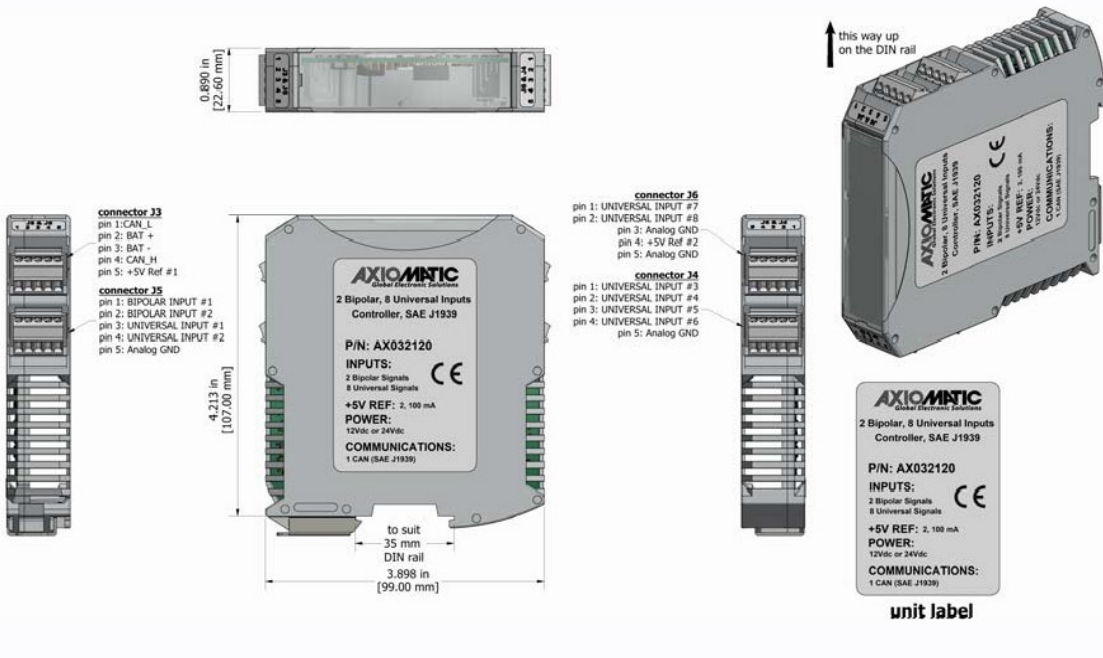

Figure 3.0 – Dimensions of AX032120

Table 3.0 – Pin out: AX032100

| Power and CAN (J3) | | Bipolar Inputs 1-2, Universal Inputs 1-2 (J5) | | Universal Inputs 7-8 (J6) | | Universal Inputs 3-6 (J4) | |
|--------------------|-----------------|---|-------------------------------|---------------------------|-------------------|---------------------------|-------------------|
| PIN # | Function | PIN # | Function | PIN # | Function | PIN # | |
| 1 | CAN_L | 1 | Bipolar Analog/Signal Input 1 | 1 | Universal Input 7 | 1 | Universal Input 3 |
| 2 | BATT + | 2 | Bipolar Analog/Signal Input 2 | 2 | Universal Input 8 | 2 | Universal Input 4 |
| 3 | BATT – | 3 | Universal Input 1 | 3 | Input GND | 3 | Universal Input 5 |
| 4 | CAN_H | 4 | Universal Input 2 | 4 | +5V Reference 2 | 4 | Universal Input 6 |
| 5 | +5V Reference 1 | | Input GND | 5 | Input GND | 5 | Input GND |

Notes:

CANopen® is a registered community trademark of CAN in Automation e.V.

Form: TDAX032100-08/19/22