

ISOLATED DUAL CHANNEL UNIVERSAL SIGNAL CONVERTER

2 Analog (Bipolar), Resistive, Digital, Frequency (RPM) or PWM Signal Inputs

2 Analog (Bipolar), Digital, Frequency or PWM Signal Outputs

4-way Isolation, 12 or 24 Vdc

+5V reference (50 mA)

CANopen®

P/N: AX130511

Description: The isolated dual channel universal signal converter accepts two voltage, current, resistive, frequency, RPM, PWM or digital control signal inputs and converts them into two signal outputs (analog voltage, analog current or digital signal). The control can be networked to a CANopen® networked engine control system. The unit has 4-way isolation between power, inputs, outputs and CAN.

Using the Electronic Assistant programming tool, the user can select the desired inputs from the following signal options.

- 0-5 V, 0-10 Vdc, +/- 5 Vdc, or +/- 10 Vdc
- 4-20 mA, 0-20 mA or 0-200 mA
- 20 Ohms to 250 kOhm
- Frequency/RPM
- PWM
- or Digital (Active High or Active Low)



A +5V, 50 mA reference is available to power a sensor input.

The outputs can also be programmed as 0-5 Vdc, 0-10 Vdc, +/- 5 Vdc, +/- 10 Vdc, 0-20 mA, 4-20 mA, Frequency, RPM, PWM or digital on/off signals.

A rugged power supply interface accepts 12 Vdc or 24 Vdc nominal for battery powered machine applications. The unit carries an IP67 rating. The rugged enclosure with 12 pin TE Deutsch connector is suitable for harsh environments. It operates from -40 to 85°C (-40 to 185°F). The sophisticated control algorithms allow the user to program the controller for a wide range of applications without the need for customer software.

Applications:

- power gen set engine control systems
- oil and gas equipment automation
- off-highway machine automation

Ordering Part Numbers:

Isolated Dual Channel Universal Signal Converter, CANopen®: **AX130511**

EDS File

Accessories:

Mating Plug Kit: **PL-DTM06-12SA**

Block Diagram

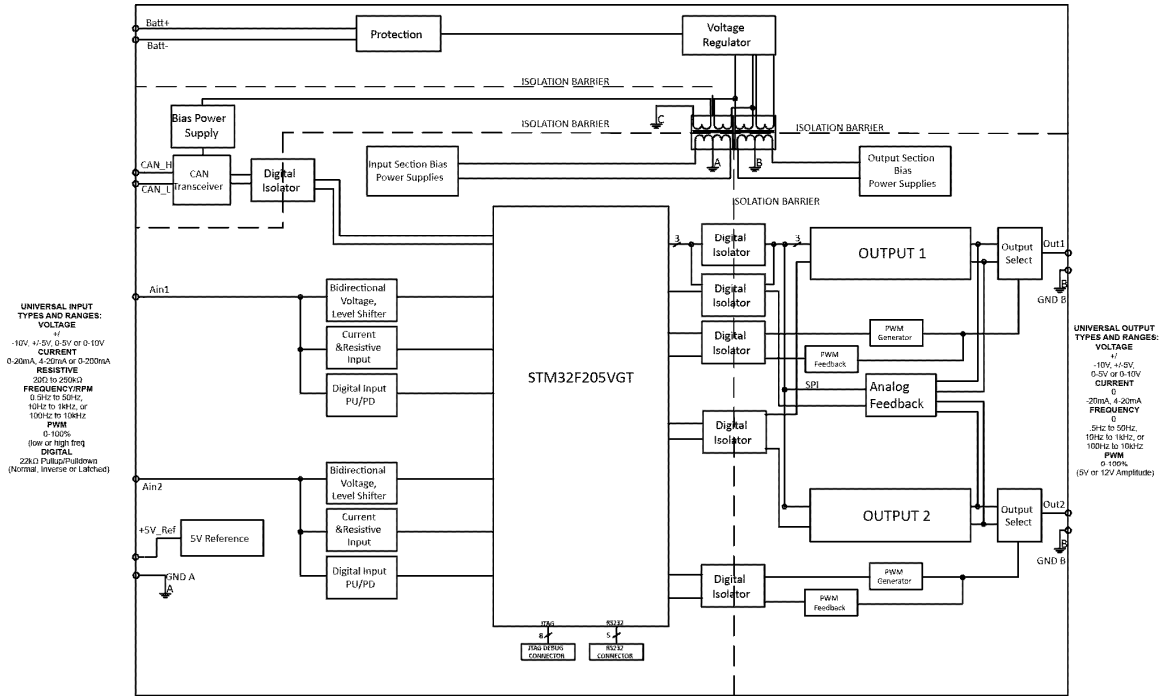

Technical Specifications:

Specifications are indicative and subject to change. Actual performance will vary depending on the application and operating conditions. Users should satisfy themselves that the product is suitable for use in the intended application. All our products carry a limited warranty against defects in material and workmanship. Please refer to our Warranty, Application Approvals/Limitations and Return Materials Process as described on www.axiomatic.com/service.html.

Power Supply

Power Supply Input	12 Vdc or 24 Vdc nominal 9...36 Vdc power supply range Shutdown voltage is 8.0 Vdc.
Protection	Reverse polarity protection Overvoltage protection is up to 45 V.

Inputs

Inputs	2 Universal Signal Inputs User programmable as Voltage, Current, Resistive, Frequency, RPM, PWM or Digital signal inputs types. Refer to Table 1.0.
--------	---

Table 1.0 –User Programmable Universal Inputs																																																	
Analog & Digital Input Functions	Voltage Input, Current Input, Resistive Input or Digital Input																																																
Voltage Input	0-5 V (Impedance 110 k Ω) 0-10 V (Impedance 130 k Ω) +/- 5V (Impedance 110 k Ω) +/- 10V (Impedance 130 k Ω)																																																
Current Input	0-200 mA (Impedance 5 Ω); 1V max. 0-20 mA (Impedance 249 Ω) 4-20 mA (Impedance 249 Ω)																																																
Resistive	20 Ohms to 250 kOhms Self-calibrating																																																
Digital Input Level	Accepts 5 V TTL Accepts up to Vps Threshold: Low <1 V High >2.2 V																																																
Digital Input	Active High or Active Low with 10 kOhm pull-up or pull-down																																																
Timer Input Functions	PWM Input, Frequency Input, RPM Input																																																
PWM Input	Low Frequency (10 Hz to 1 kHz) High Frequency (100 Hz to 10 kHz) 0 to 100% D.C.																																																
Frequency/RPM Input	0.5 Hz to 50 Hz; 10 Hz to 1 kHz; or 100 Hz to 10 kHz 1 to 99% D.C.																																																
Maximum and Minimum Ratings	<table border="1"> <thead> <tr> <th>Characteristic</th> <th>Min</th> <th>Max</th> <th>Units</th> </tr> </thead> <tbody> <tr> <td>Power Supply</td> <td>9</td> <td>36</td> <td>V dc</td> </tr> <tr> <td>Voltage Input</td> <td>0</td> <td>36</td> <td>V dc</td> </tr> <tr> <td>Current Input 0(4)-20 mA</td> <td>0</td> <td>12</td> <td>Vdc</td> </tr> <tr> <td>Current Input 0-200 mA</td> <td>0</td> <td>1V</td> <td>Vdc</td> </tr> <tr> <td>Resistive Input</td> <td>30</td> <td>250 000</td> <td>Ω</td> </tr> <tr> <td>Digital Input</td> <td>0</td> <td>36</td> <td>Vdc</td> </tr> <tr> <td>PWM Duty Cycle</td> <td>0</td> <td>100</td> <td>%</td> </tr> <tr> <td>PWM Low Frequency</td> <td>10</td> <td>1 000</td> <td>Hz</td> </tr> <tr> <td>PWM High Frequency</td> <td>100</td> <td>10 000</td> <td>Hz</td> </tr> <tr> <td>PWM Voltage pk - pk</td> <td>0</td> <td>36</td> <td>V dc</td> </tr> <tr> <td>RPM Frequency</td> <td>0.5</td> <td>10 000</td> <td>Hz</td> </tr> </tbody> </table>	Characteristic	Min	Max	Units	Power Supply	9	36	V dc	Voltage Input	0	36	V dc	Current Input 0(4)-20 mA	0	12	Vdc	Current Input 0-200 mA	0	1V	Vdc	Resistive Input	30	250 000	Ω	Digital Input	0	36	Vdc	PWM Duty Cycle	0	100	%	PWM Low Frequency	10	1 000	Hz	PWM High Frequency	100	10 000	Hz	PWM Voltage pk - pk	0	36	V dc	RPM Frequency	0.5	10 000	Hz
Characteristic	Min	Max	Units																																														
Power Supply	9	36	V dc																																														
Voltage Input	0	36	V dc																																														
Current Input 0(4)-20 mA	0	12	Vdc																																														
Current Input 0-200 mA	0	1V	Vdc																																														
Resistive Input	30	250 000	Ω																																														
Digital Input	0	36	Vdc																																														
PWM Duty Cycle	0	100	%																																														
PWM Low Frequency	10	1 000	Hz																																														
PWM High Frequency	100	10 000	Hz																																														
PWM Voltage pk - pk	0	36	V dc																																														
RPM Frequency	0.5	10 000	Hz																																														
Input Grounds	1 provided																																																
Protection	All inputs are protected against short to GND. All inputs, except current inputs, are protected against shorts to Nominal Vps (36Vdc).																																																
Input Accuracy and Resolution	<table border="1"> <thead> <tr> <th>Input Type</th> <th>Input Range</th> <th>Accuracy</th> <th>Resolution</th> </tr> </thead> <tbody> <tr> <td rowspan="4">Voltage</td> <td>0-5V</td> <td>+/- 0.5%</td> <td>1 mV</td> </tr> <tr> <td>0-10V</td> <td>+/- 0.5%</td> <td>1 mV</td> </tr> <tr> <td>-5V to 5V</td> <td>+/- 0.5%</td> <td>1 mV</td> </tr> <tr> <td>-10V to 10V</td> <td>+/- 0.5%</td> <td>1 mV</td> </tr> <tr> <td rowspan="2">Current</td> <td>0(4)-20mA</td> <td>+/-1%</td> <td>1 μA</td> </tr> <tr> <td>0-200mA</td> <td>+/-1%</td> <td>1 μA</td> </tr> <tr> <td>Resistive</td> <td>30-250kΩ</td> <td>+/-1%</td> <td>1 Ω for lower ranges 1 kΩ for higher ranges</td> </tr> <tr> <td rowspan="3">Frequency</td> <td>0.5Hz-50Hz</td> <td>+/-0.3%</td> <td>0.01 Hz</td> </tr> <tr> <td>10Hz-1kHz</td> <td>+/-0.3%</td> <td>0.1 Hz</td> </tr> <tr> <td>100Hz-10kHz</td> <td>+/-0.3%</td> <td>1 Hz</td> </tr> <tr> <td rowspan="2">PWM</td> <td>Low Frequency</td> <td>+/-0.1%</td> <td>0.01%</td> </tr> <tr> <td>High Frequency</td> <td>+/-0.1%</td> <td>0.01%</td> </tr> </tbody> </table>	Input Type	Input Range	Accuracy	Resolution	Voltage	0-5V	+/- 0.5%	1 mV	0-10V	+/- 0.5%	1 mV	-5V to 5V	+/- 0.5%	1 mV	-10V to 10V	+/- 0.5%	1 mV	Current	0(4)-20mA	+/-1%	1 μ A	0-200mA	+/-1%	1 μ A	Resistive	30-250k Ω	+/-1%	1 Ω for lower ranges 1 k Ω for higher ranges	Frequency	0.5Hz-50Hz	+/-0.3%	0.01 Hz	10Hz-1kHz	+/-0.3%	0.1 Hz	100Hz-10kHz	+/-0.3%	1 Hz	PWM	Low Frequency	+/-0.1%	0.01%	High Frequency	+/-0.1%	0.01%			
Input Type	Input Range	Accuracy	Resolution																																														
Voltage	0-5V	+/- 0.5%	1 mV																																														
	0-10V	+/- 0.5%	1 mV																																														
	-5V to 5V	+/- 0.5%	1 mV																																														
	-10V to 10V	+/- 0.5%	1 mV																																														
Current	0(4)-20mA	+/-1%	1 μ A																																														
	0-200mA	+/-1%	1 μ A																																														
Resistive	30-250k Ω	+/-1%	1 Ω for lower ranges 1 k Ω for higher ranges																																														
Frequency	0.5Hz-50Hz	+/-0.3%	0.01 Hz																																														
	10Hz-1kHz	+/-0.3%	0.1 Hz																																														
	100Hz-10kHz	+/-0.3%	1 Hz																																														
PWM	Low Frequency	+/-0.1%	0.01%																																														
	High Frequency	+/-0.1%	0.01%																																														

Outputs

Outputs	<p>2 Isolated Signal Outputs Voltage, Current or Digital (Digital/Frequency or PWM) The outputs are user selectable as follows. Refer to Table 2.0.</p> <table border="1"> <thead> <tr> <th colspan="6">Table 2.0: Programmable Outputs</th> </tr> </thead> <tbody> <tr> <td>Analog Voltage or Current Outputs:</td> <td colspan="5"> <p><u>Voltage Output:</u> 0-5 Vdc, 0-10 Vdc, +/- 5Vdc or +/- 10Vdc Maximum load is 50 mA.</p> <p><u>Current Output:</u> 0-20 mA or 4-20 mA Maximum load resistance is < 500 Ohms. Compliance Voltage is 10V.</p> </td> </tr> <tr> <td>PWM, Frequency or Mixed PWM/Frequency Output:</td> <td colspan="5"> <p>0.1 Hz to 50 kHz 0-100% D.C. 5 V or 12 V Amplitude Push pull output Maximum load is 50 mA. Over-current protection (50 mA)</p> </td> </tr> <tr> <td>Digital Output:</td> <td colspan="5"> <p>Digital Level Digital ON/OFF 5 V or 12 V Amplitude Maximum load is 50 mA.</p> </td> </tr> </tbody> </table>					Table 2.0: Programmable Outputs						Analog Voltage or Current Outputs:	<p><u>Voltage Output:</u> 0-5 Vdc, 0-10 Vdc, +/- 5Vdc or +/- 10Vdc Maximum load is 50 mA.</p> <p><u>Current Output:</u> 0-20 mA or 4-20 mA Maximum load resistance is < 500 Ohms. Compliance Voltage is 10V.</p>					PWM, Frequency or Mixed PWM/Frequency Output:	<p>0.1 Hz to 50 kHz 0-100% D.C. 5 V or 12 V Amplitude Push pull output Maximum load is 50 mA. Over-current protection (50 mA)</p>					Digital Output:	<p>Digital Level Digital ON/OFF 5 V or 12 V Amplitude Maximum load is 50 mA.</p>																										
Table 2.0: Programmable Outputs																																																			
Analog Voltage or Current Outputs:	<p><u>Voltage Output:</u> 0-5 Vdc, 0-10 Vdc, +/- 5Vdc or +/- 10Vdc Maximum load is 50 mA.</p> <p><u>Current Output:</u> 0-20 mA or 4-20 mA Maximum load resistance is < 500 Ohms. Compliance Voltage is 10V.</p>																																																		
PWM, Frequency or Mixed PWM/Frequency Output:	<p>0.1 Hz to 50 kHz 0-100% D.C. 5 V or 12 V Amplitude Push pull output Maximum load is 50 mA. Over-current protection (50 mA)</p>																																																		
Digital Output:	<p>Digital Level Digital ON/OFF 5 V or 12 V Amplitude Maximum load is 50 mA.</p>																																																		
Output Accuracy and Resolution	<table border="1"> <thead> <tr> <th>Output Type</th> <th>Output Range</th> <th>Output Accuracy</th> <th>Output Resolution</th> <th>Output Feedback Accuracy</th> </tr> </thead> <tbody> <tr> <td rowspan="4">Voltage</td> <td>0-5V</td> <td>+/- 0.5%</td> <td>1.2 mV</td> <td>+/- 1%</td> </tr> <tr> <td>0-10V</td> <td>+/- 0.5%</td> <td>2.44 mV</td> <td>+/- 1%</td> </tr> <tr> <td>+/- 5Vdc</td> <td>+/- 0.5%</td> <td>2.44 mV</td> <td>+/- 1%</td> </tr> <tr> <td>+/- 10Vdc</td> <td>+/- 0.5%</td> <td>4.88 mV</td> <td>+/- 1%</td> </tr> <tr> <td>Current</td> <td>0(4)-20mA</td> <td>+/- 0.5%</td> <td>4.88 μA</td> <td>+/- 2%</td> </tr> <tr> <td>Digital</td> <td>On/Off</td> <td>N/A</td> <td>N/A</td> <td>N/A</td> </tr> <tr> <td>Frequency</td> <td>0.1Hz-50kHz</td> <td>+/- 0.1%</td> <td>0.01 – 40 Hz</td> <td>+/- 0.5%</td> </tr> <tr> <td rowspan="2">PWM</td> <td>Low Frequency</td> <td>+/- 0.5%</td> <td>0.01%</td> <td>+/- 0.8%</td> </tr> <tr> <td>High Frequency</td> <td>+/- 0.5%</td> <td>0.01%</td> <td>+/- 0.8%</td> </tr> </tbody> </table>					Output Type	Output Range	Output Accuracy	Output Resolution	Output Feedback Accuracy	Voltage	0-5V	+/- 0.5%	1.2 mV	+/- 1%	0-10V	+/- 0.5%	2.44 mV	+/- 1%	+/- 5Vdc	+/- 0.5%	2.44 mV	+/- 1%	+/- 10Vdc	+/- 0.5%	4.88 mV	+/- 1%	Current	0(4)-20mA	+/- 0.5%	4.88 μ A	+/- 2%	Digital	On/Off	N/A	N/A	N/A	Frequency	0.1Hz-50kHz	+/- 0.1%	0.01 – 40 Hz	+/- 0.5%	PWM	Low Frequency	+/- 0.5%	0.01%	+/- 0.8%	High Frequency	+/- 0.5%	0.01%	+/- 0.8%
Output Type	Output Range	Output Accuracy	Output Resolution	Output Feedback Accuracy																																															
Voltage	0-5V	+/- 0.5%	1.2 mV	+/- 1%																																															
	0-10V	+/- 0.5%	2.44 mV	+/- 1%																																															
	+/- 5Vdc	+/- 0.5%	2.44 mV	+/- 1%																																															
	+/- 10Vdc	+/- 0.5%	4.88 mV	+/- 1%																																															
Current	0(4)-20mA	+/- 0.5%	4.88 μ A	+/- 2%																																															
Digital	On/Off	N/A	N/A	N/A																																															
Frequency	0.1Hz-50kHz	+/- 0.1%	0.01 – 40 Hz	+/- 0.5%																																															
PWM	Low Frequency	+/- 0.5%	0.01%	+/- 0.8%																																															
	High Frequency	+/- 0.5%	0.01%	+/- 0.8%																																															
Voltage Reference	+5V, 50 mA Ground is shared with Input Grounds.																																																		
Protection for Output Terminals	Fully protected against short circuit to output ground. Unit will fail safe in the case of a short circuit condition, self-recovering when the short is removed.																																																		

General Specifications

Microprocessor	STM32F205VGT
Isolation	300 Vrms 4-way Digital Isolation (Power, Inputs, Outputs and CAN are isolated from each other.)
Typical Quiescent Current	150 mA @ 12Vdc; 75 mA @ 24Vdc
Response Time	30 mSec.
Control Logic	Standard embedded software is provided. Refer to the User Manual for details.
Communications	1 Isolated CAN port (CANopen®)
Network Termination	It is necessary to terminate the network with external termination resistors. The resistors are 120 Ohm, 0.25W minimum, metal film or similar type. They should be placed between CAN_H and CAN_L terminals at both ends of the network.
User Interface	EDS File Standard CANopen® tools (not supplied)
Operating Conditions	-40 to 85 °C (-40 to 185 °F)
Storage Temperature	-55 to 125 °C (-67 to 257°F)
Protection	IP67
Vibration	MIL-STD-202G, Test 204D and 214A (Sine and Random) 10 g peak (Sine) 7.86 Grms peak (Random)
Shock	MIL-STD-202G, Test 213B 50g
Weight	0.55 lb. (0.249 kg)

Enclosure	High Temperature Nylon housing – TE Deutsch PCB Enclosure (EEC-325X4B) 4.64 x 5.232 x 1.41 inches 117.86 x 132.90 x 35.84 mm (W x L x H excluding mating plugs) Refer to the dimensional drawing.
Installation	<p>For mounting information, refer to the dimensional drawing.</p> <p>Mounting holes sized for ¼ inch or M6 bolts. The bolt length will be determined by the end-user's mounting plate thickness. The mounting flange of the controller is 0.63 inches (16 mm) thick.</p> <p>If the module is mounted without an enclosure, it should be mounted vertically with connectors facing left and right to reduce likelihood of moisture entry.</p> <p>The CAN wiring is considered intrinsically safe. The power wires are not considered intrinsically safe and so in hazardous locations, they need to be located in conduit or conduit trays at all times. The module must be mounted in an enclosure in hazardous locations for this purpose.</p> <p>No wire or cable harness should exceed 30 meters in length. The power input wiring should be limited to 10 meters.</p> <p>All field wiring should be suitable for the operating temperature range.</p> <p>Install the unit with appropriate space available for servicing and for adequate wire harness access (6 inches or 15 cm) and strain relief (12 inches or 30 cm).</p>

Dimensional Drawing

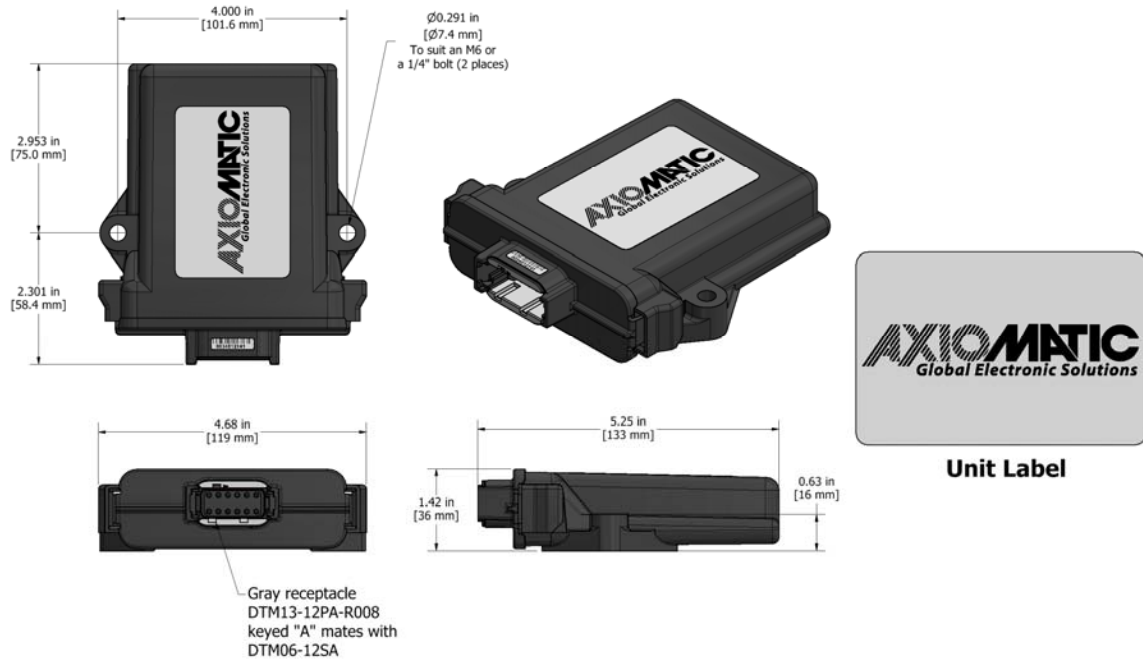

Electrical Connections	<p>TE Deutsch DTM series 12 pin receptacle (P/N: DTM13-12PA-R008)</p> <p>20 AWG wire is recommended for use with contacts 0462-201-20141.</p> <p>Mating plug KIT: Available from Axiomatic as p/n: PL-DTM06-12SA. It is comprised of the following Deutsch IPD parts: plug (DTM06-12SA); wedgelock (WM12S); and 12 contacts (0462-201-20141) as well as 6 sealing plugs (0413-204-2005).</p> <table border="1" data-bbox="625 426 1307 814"> <thead> <tr> <th>Pin #</th> <th>Description</th> </tr> </thead> <tbody> <tr> <td>1</td> <td>Analog/Digital Input 1</td> </tr> <tr> <td>2</td> <td>Input GND</td> </tr> <tr> <td>3</td> <td>Analog/Digital Input 2</td> </tr> <tr> <td>4</td> <td>CAN H</td> </tr> <tr> <td>5</td> <td>CAN L</td> </tr> <tr> <td>6</td> <td>Power +</td> </tr> <tr> <td>7</td> <td>Power -</td> </tr> <tr> <td>8</td> <td>+5V Reference</td> </tr> <tr> <td>9</td> <td>Analog/Digital Output 2+</td> </tr> <tr> <td>10</td> <td>Output GND 2</td> </tr> <tr> <td>11</td> <td>Output GND 1</td> </tr> <tr> <td>12</td> <td>Analog/Digital Output 1+</td> </tr> </tbody> </table>	Pin #	Description	1	Analog/Digital Input 1	2	Input GND	3	Analog/Digital Input 2	4	CAN H	5	CAN L	6	Power +	7	Power -	8	+5V Reference	9	Analog/Digital Output 2+	10	Output GND 2	11	Output GND 1	12	Analog/Digital Output 1+
Pin #	Description																										
1	Analog/Digital Input 1																										
2	Input GND																										
3	Analog/Digital Input 2																										
4	CAN H																										
5	CAN L																										
6	Power +																										
7	Power -																										
8	+5V Reference																										
9	Analog/Digital Output 2+																										
10	Output GND 2																										
11	Output GND 1																										
12	Analog/Digital Output 1+																										

CANopen® is a registered community trademark of CAN in Automation e.V.

Form: TDAX130511-02/02/22