

4 VAC or Current Inputs, 4 Analog Outputs CAN Controller

CAN (SAE J1939)

DIN rail mount

P/N: AX130550

Features:

- Four AC Voltage or Current Inputs are selectable as the following.
 - 0-5 VAC
 - 0-200 mA
- Four analog signal outputs are configurable as the following signals:
 - Analog voltage (0-5V, 0-10V, +/-5V, or +/- 10V);
 - Or Analog current (4-20 mA, 0-20 mA);
- 12Vdc or 24Vdc nominal
- SAE J1939 with auto-baud-rate detection
- Operates from -40 to 85°C (-40 to 185°F).
- Two LED indicators
- IP20
- DIN rail mount
- Screw terminal connections
- Configurable via Electronic Assistant



Applications:

- Railway equipment, construction equipment

Ordering Part Numbers:

4 AC Voltage or Current Input, 4 Analog Output CAN Controller, SAE J1939: **AX130550**

Accessories:

Electronic Assistant: **AX070502**

Description: The controller accepts 4 AC voltage or current inputs. It is connected to the SAE J1939 CAN bus. Power is 12V or 24Vdc nominal. Up to four (4) analog signal outputs are user selectable from the following.

- 0-5 V, 0-10 Vdc, +/- 5 Vdc or +/- 10 Vdc
- 4-20 mA or 0-20 mA

LED's indicate operational status. The enclosure is DIN rail mount. It operates from -40 to 85°C (-40 to 185°F). Standard embedded software is provided and is configurable using the Electronic Assistant (EA).

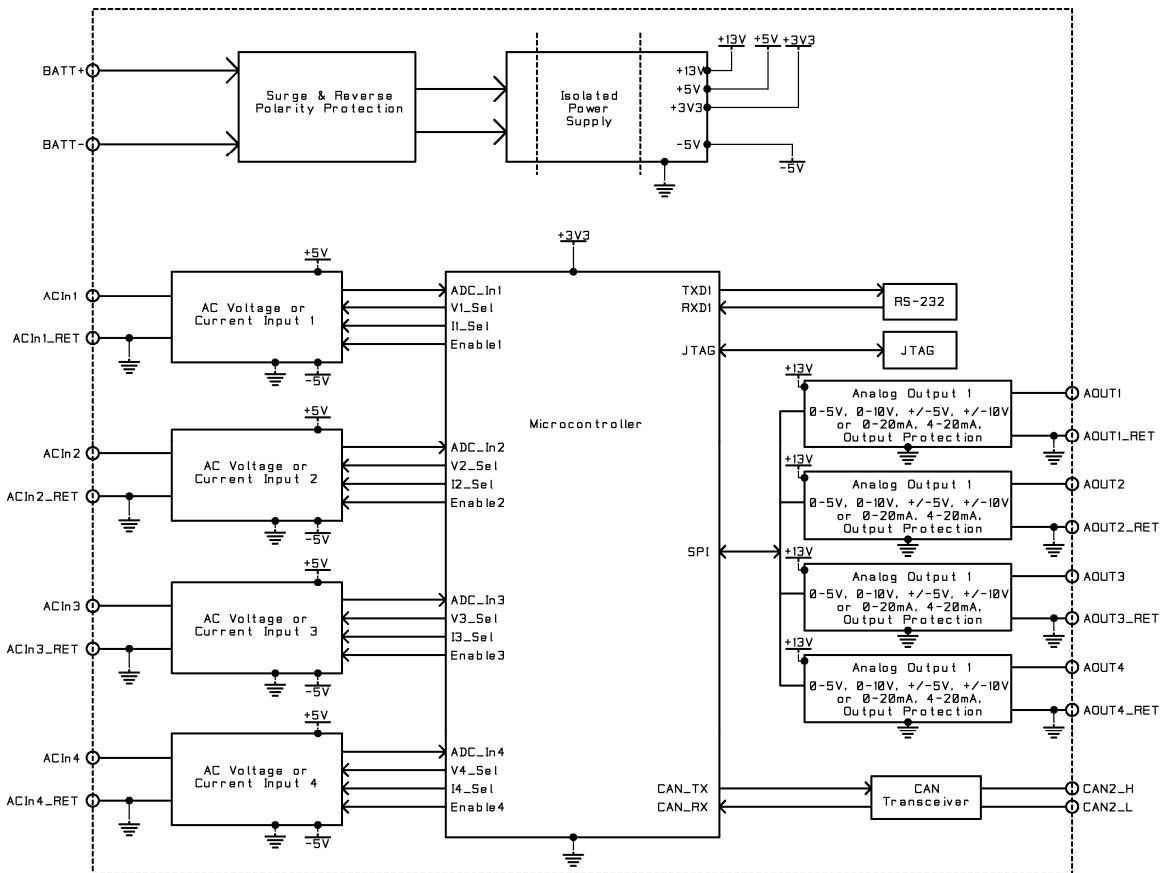

Figure 1.0 – Block Diagram

Technical Specifications:

Specifications are indicative and subject to change. Actual performance will vary depending on the application and operating conditions. Users should satisfy themselves that the product is suitable for use in the intended application. All our products carry a limited warranty against defects in material and workmanship. Please refer to our Warranty, Application Approvals/Limitations and Return Materials Process as described on www.axiomatic.com/service.html.

Power Supply

Power Supply Input	12 Vdc or 24 Vdc nominal 9...36 Vdc power supply range Shutdown voltage is 7.0 Vdc.
Protection	Surge and transient protection Reverse polarity protection Overvoltage protection is up to 40 V.

Inputs

Inputs	4 AC Inputs, user selectable as: <ul style="list-style-type: none"> 0-5VAC peak 0-200 mA peak Frequency range: 45-75Hz												
Input Load	Voltage Input: 250 kΩ Current Input: 10 Ω												
Input Ground	4 provided												
Protection	All inputs are protected against short to GND and shorts to Nominal Vps (36Vdc).												
Input Accuracy and Resolution	<table border="1"> <thead> <tr> <th>Input Type</th> <th>Input Range</th> <th>Accuracy</th> <th>Resolution</th> </tr> </thead> <tbody> <tr> <td>Voltage</td> <td>0-5V</td> <td>+/-2%</td> <td>1 mV</td> </tr> <tr> <td>Current</td> <td>0-200mA</td> <td>+/-2%</td> <td>24 μA</td> </tr> </tbody> </table>	Input Type	Input Range	Accuracy	Resolution	Voltage	0-5V	+/-2%	1 mV	Current	0-200mA	+/-2%	24 μA
Input Type	Input Range	Accuracy	Resolution										
Voltage	0-5V	+/-2%	1 mV										
Current	0-200mA	+/-2%	24 μA										

Outputs

Outputs	<p>4 Analog Signal Outputs Voltage or Current The outputs are user selectable as follows. Refer to Table 1.0.</p> <table border="1"> <thead> <tr> <th colspan="2">Table 1.0: Programmable Outputs</th> </tr> </thead> <tbody> <tr> <td>Analog Voltage or Current Outputs:</td> <td> <p><u>Voltage Output:</u> 0-5 Vdc, 0-10 Vdc, +/- 5Vdc or +/- 10Vdc Maximum load is 50 mA.</p> <p><u>Current Output:</u> 0-20 mA or 4-20 mA Maximum load resistance is < 500 Ohms. Compliance Voltage is 10V.</p> </td> </tr> </tbody> </table>	Table 1.0: Programmable Outputs		Analog Voltage or Current Outputs:	<p><u>Voltage Output:</u> 0-5 Vdc, 0-10 Vdc, +/- 5Vdc or +/- 10Vdc Maximum load is 50 mA.</p> <p><u>Current Output:</u> 0-20 mA or 4-20 mA Maximum load resistance is < 500 Ohms. Compliance Voltage is 10V.</p>																	
Table 1.0: Programmable Outputs																						
Analog Voltage or Current Outputs:	<p><u>Voltage Output:</u> 0-5 Vdc, 0-10 Vdc, +/- 5Vdc or +/- 10Vdc Maximum load is 50 mA.</p> <p><u>Current Output:</u> 0-20 mA or 4-20 mA Maximum load resistance is < 500 Ohms. Compliance Voltage is 10V.</p>																					
Output Accuracy and Resolution	<table border="1"> <thead> <tr> <th>Output Type</th> <th>Output Range</th> <th>Output Accuracy</th> <th>Output Resolution</th> </tr> </thead> <tbody> <tr> <td rowspan="4">Voltage</td> <td>0-5V</td> <td>+/- 0.5%</td> <td>1 mV</td> </tr> <tr> <td>0-10V</td> <td>+/- 0.5%</td> <td>1 mV</td> </tr> <tr> <td>+/- 5Vdc</td> <td>+/- 0.5%</td> <td>1 mV</td> </tr> <tr> <td>+/- 10Vdc</td> <td>+/- 0.5%</td> <td>1 mV</td> </tr> <tr> <td>Current</td> <td>0(4)-20mA</td> <td>+/- 0.5%</td> <td>0.5 µA</td> </tr> </tbody> </table>	Output Type	Output Range	Output Accuracy	Output Resolution	Voltage	0-5V	+/- 0.5%	1 mV	0-10V	+/- 0.5%	1 mV	+/- 5Vdc	+/- 0.5%	1 mV	+/- 10Vdc	+/- 0.5%	1 mV	Current	0(4)-20mA	+/- 0.5%	0.5 µA
Output Type	Output Range	Output Accuracy	Output Resolution																			
Voltage	0-5V	+/- 0.5%	1 mV																			
	0-10V	+/- 0.5%	1 mV																			
	+/- 5Vdc	+/- 0.5%	1 mV																			
	+/- 10Vdc	+/- 0.5%	1 mV																			
Current	0(4)-20mA	+/- 0.5%	0.5 µA																			
Output Grounds	All 4 output grounds are connected together internally.																					
Protection for Output Terminals	Fully protected against short circuit to output ground or +Vcc. Unit will fail safe in the case of a short circuit condition, self-recovering when the short is removed.																					

General Specifications

Microprocessor	STM32F405RGT7 32-bit, 1MByte flash memory
Isolation	1-way Isolation (Power) 850 Vrms
Typical Quiescent Current	88 mA @ 12Vdc; 44 mA @ 24Vdc typical
Response Time	1ms
LED Indicators	2 bicolour LED's (Red and Green) Heartbeat, input fault and CAN fault indication
CAN Communications	1 Isolated CAN port (SAE J1939) Auto baud rate detection (CANopen® model is AX130551.)
Control Logic	Standard embedded software is provided and is configurable using the Electronic Assistant (EA). Any of the outputs can be configured to use any of the inputs either as a control signal or an enable signal as well as use the CAN network data. The user can configure the control logic using the following Function Blocks. For more details on control logic, refer to the User Manual.
User Interface	Electronic Assistant P/N: AX070502
Software Reflashing	Electronic Assistant P/N: AX070502
Operating Conditions	-40 to 85 °C (-40 to 185 °F)
Storage Temperature	-55 to 125 °C (-67 to 257°F)
Protection	IP20
Weight	0.25 lb. (0.113 kg)
Enclosure and Dimensions	Phoenix Contact: ME MAX 22,5 G 2-2 KMGY – 2713625 (vented) Polyamide, UL94V0, cULus recognized, China RoHS DIN rail TH 35-7.5 99 x 114.5 x 22.5 x 99 mm (L x H x W x D) Refer to Figure 2.0.
Electrical Connections	4 sets of 5 Phoenix Contact MC 1,5/ 5-ST-3,5 GY7035 3.5 mm screw terminal Accepts 24-14 AWG wire. Refer to Table 3.0 and Figure 2.0. for pin out.
Installation	DIN rail mount TH 35-7.5
Network Termination	It is necessary to terminate the network with external termination resistors. The resistors are 120 Ohm, 0.25W minimum, metal film or similar type. They should be placed between CAN_H and CAN_L terminals at both ends of the network.

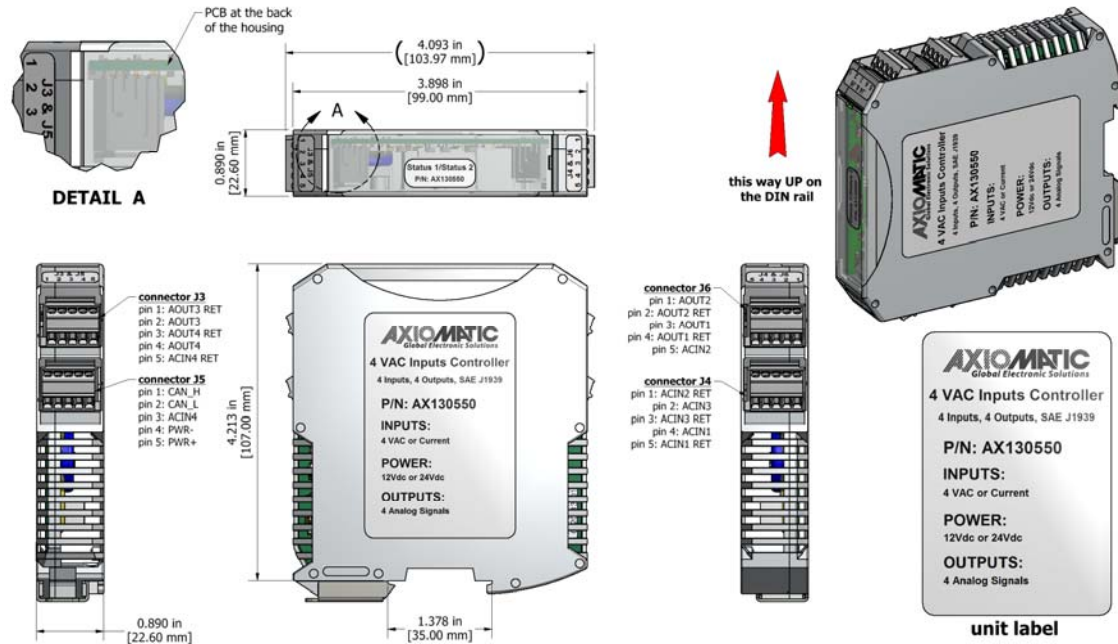

Figure 2.0 – Dimensions

Table 3.0 – Pin out: AX130550

Outputs (J3)		Power and CAN (J5)		Inputs (J4)		Inputs and Outputs (J6)	
PIN #	Function	PIN #	Function	PIN #	Function	PIN #	
1	Analog Output 3_return	1	CAN H	1	AC Voltage or Current Input 2_return	1	Analog Output 2
2	Analog Output 3	2	CAN L	2	AC Voltage or Current Input 3	2	Analog Output 2_return
3	Analog Output 4_return	3	AC Voltage or Current Input 4	3	AC Voltage or Current Input 3_return	3	Analog Output 1
4	Analog Output 4	4	BATT-	4	AC Voltage or Current Input 1	4	Analog Output 1_return
5	AC Voltage or Current Input 4_return	5	BATT +	5	AC Voltage or Current Input 1_return	5	AC Voltage or Current Input 2

Form: TDAX130550-06/21/21