

**Converts CAN messages into a PWM signal
for communication with Engine Control Modules**

Features:

- PWM Signal output to communicate with an engine ECM
- Output is user configurable as Frequency or digital
- 1 isolated CAN port (SAE J1939) to read engine speed messages or other engine information with auto-baud-rate detect
- Operational 9...36 Vdc (12 Vdc or 24 Vdc)
- Integrated TE Deutsch 6-pin connector
- Compact, fully sealed enclosure, IP67
- Meets the surge requirements of SAE J1445
- Designed for EMC compliance
- Configure with Axiomatic Electronic Assistant



Applications:

- Power Generator Set Control Systems

Ordering Part Numbers:

CAN-PWM Signal Converter, 1 SAE J1939 with auto-baud-rate-detect - P/N: **AX130700AB**
CAN-PWM Signal Converter, 1 CANopen - P/N: **AX130701**

Accessories:

Configuration Tool: Electronic Assistant P/N: **AX070502**
Mating Plug KIT: **AX070119**

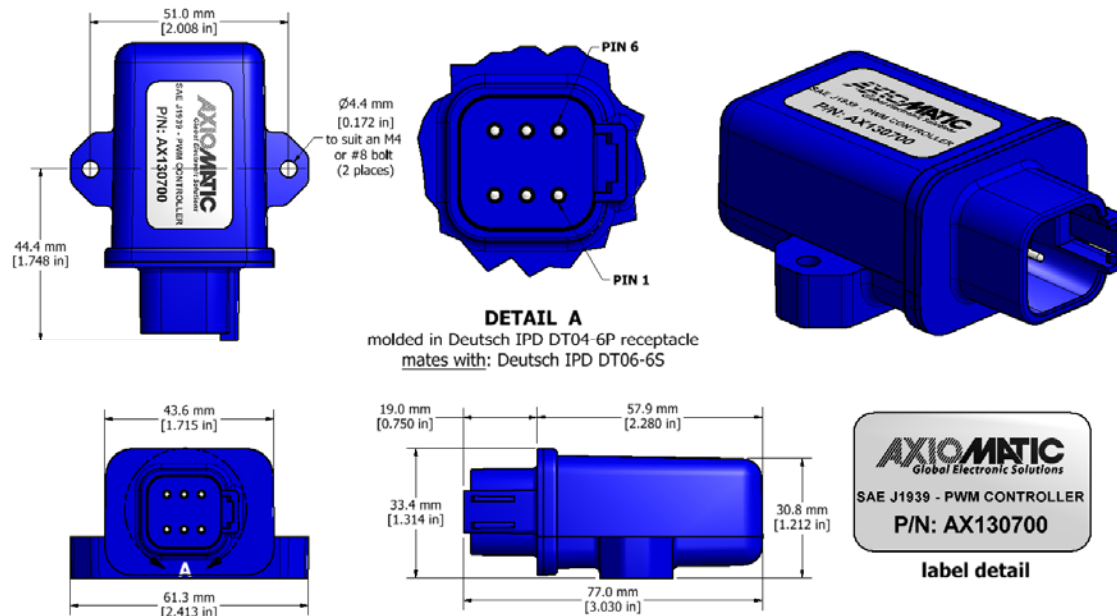

Figure 1.0 – Dimensional Drawing

Technical Specifications: Specifications are indicative and subject to change. Actual performance will vary depending on the application and operating conditions. Users should satisfy themselves that the product is suitable for use in the intended application. All our products carry a limited warranty against defects in material and workmanship. Please refer to our Warranty, Application Approvals/Limitations and Return Materials Process as described on <https://www.axiomatic.com/service/>.

Power

Power Supply Input - Nominal	12 V or 24 Vdc nominal; 9...36 Vdc The minimum allowable supply voltage for the power pin is 7 Vdc.
Surge Protection	Meets the surge requirements of SAE J1445
Reverse Polarity Protection	Provided

Output

Output	1 Output configurable as PWM/Frequency or Digital PWM Signal, Frequency Signal or Mixed Output <ul style="list-style-type: none"> • 1 Hz to 20 kHz • 0-100% D.C. (User configurable) • 5V or 12V amplitude • Push pull output • Maximum load is 50 mA (at 5V) or 30 mA (at 12V). • Over-current protection (50 mA) Digital Level <ul style="list-style-type: none"> • Digital On/Off • 5V or 12V Amplitude • Maximum load is 50 mA (at 5V) or 30 mA (at 12V).
Output Accuracy and Resolution	Accuracy: PWM Signal: +/-0.01%; Frequency Signal: +/-0.005% Resolution: 0.01%
Output Feedback Accuracy	PWM Signal: 0.5%; Frequency Signal: 0.5%

Control Software

Software Platform	The CAN-PWM Signal Converter comes pre-programmed with standard logic.
-------------------	--

General Specifications

Memory	STM32F103CBT7; 32-bit, 128 Kbytes Flash Program Memory																
CAN Port	Model: AX130700AB - 1 CAN (SAE J1939) 250kbit/s, 500kbit/s, 667kbit/s, 1Mbit/s. Automatic Baud Rate Detection Model AX30701 – 1 CANopen®																
Isolation	300 Vrms isolation for CAN port																
Quiescent Current Draw	16 mA @ 24Vdc Typical																
Response Time	10 mSec. Typical																
Operating Conditions	-40 to 85°C (-40 to 185°F)																
Weight	0.15 lbs. (0.068 kg)																
Protection Rating	IP67																
Vibration	MIL-STD-202G, Test 204D and 214A (Sine and Random) 10 g peak (Sine); 7.86 Grms peak (Random)																
Shock	MIL-STD-202G, Test 213B, 50 g																
Enclosure and Dimensions	Plastic Enclosure, Nylon 6-6 with 30% glass fill Integral TE Deutsch connector Refer to Figure 1.0, dimensional drawing.																
Electrical Connections	6 pin TE Deutsch connector P/N: DT04-6P A mating plug kit is available as Axiomatic P/N: AX070119 . <table border="1" style="margin-left: 20px;"> <thead> <tr> <th colspan="2">CAN and I/O Connector</th> </tr> <tr> <th>Pin #</th> <th>Description</th> </tr> </thead> <tbody> <tr> <td>1</td> <td>BATT+</td> </tr> <tr> <td>2</td> <td>Output +</td> </tr> <tr> <td>3</td> <td>CAN_H</td> </tr> <tr> <td>4</td> <td>CAN_L</td> </tr> <tr> <td>5</td> <td>Output -</td> </tr> <tr> <td>6</td> <td>BATT-</td> </tr> </tbody> </table>	CAN and I/O Connector		Pin #	Description	1	BATT+	2	Output +	3	CAN_H	4	CAN_L	5	Output -	6	BATT-
CAN and I/O Connector																	
Pin #	Description																
1	BATT+																
2	Output +																
3	CAN_H																
4	CAN_L																
5	Output -																
6	BATT-																
User Interface, Reflashing	Model AX130700AB: Axiomatic Electronic Assistant AX070502 Model AX130701: EDS File and standard CANopen® tools																

Form: TDAX130700AB-03/17/22