

## Automotive Ethernet Converter

P/N: AX141500-X

### Features:

- 12V, 24Vdc input power (nominal) for connection to a battery
- 1 Automotive Ethernet port (100 Mbps)
- 1 Ethernet port (100 Mbps)
- Power, Link and Speed LED indicators
- Surge, reverse polarity, input overvoltage, and input undervoltage protection
- IP67
- Compact, 2 M12 connectors
- CE marking
- Suitable for high vibration and shock environments



### Applications:

- Off-highway equipment, mining equipment, industrial trucks

### Ordering Part Number:

Automotive Ethernet Converter, Master: **AX141500-M**

Automotive Ethernet Converter, Slave: **AX141500-S**

*Refer to description below for details on the -M and -S settings.*

#### KITS:

**AX141500-MK:** KIT (AX141500-M Automotive Ethernet Converter - Master, AX070531 Cable, AX070532 Cable)

**AX141500-SK:** KIT (AX141500-S Automotive Ethernet Converter - Slave, AX070531 Cable, AX070532 Cable)

Accessories: The cables can also be ordered individually.

**AX070531** Ethernet and Power Cable - 1.7m (5.5 ft.), 8-pin M12 A-coded, Underminated Leads, Ethernet Jack

**AX070532** CAN Cable - 1.5 m (5 ft.), 5-pin M12 A-coded, Underminated Leads

**Description:** The Axiomatic Automotive Ethernet Converter provides a purely physical, bi-directional conversion between Automotive Ethernet (100BASE-T1), and Ethernet (100BASE-TX) via PHY transceivers. No packets are stored or modified in this device. The converter supports a baud rate of 100 Mbit/s. Status LEDs provide information on connection link, and communication. The converter is designed for the harsh environments of off-highway or industrial equipment. Automotive Ethernet networks use a 2 wire, unshielded, twisted pair UTP cable and save cabling costs for the machine builder. The Master model (-M) works if the connected device has a transceiver set to slave mode. The Slave model (-S) works when the connected device has a transceiver set to master mode. Hard setting the master/slave relationship saves on setup-time costs and ensures that the Automotive Ethernet link is established quickly. As a comparison, regular Ethernet converters rely on auto-negotiation to determine master and slave. **Before, selecting the model code to order from Axiomatic, determine the master or slave setting of the device that will be connected to the Axiomatic model.**

## Functional Block Diagram

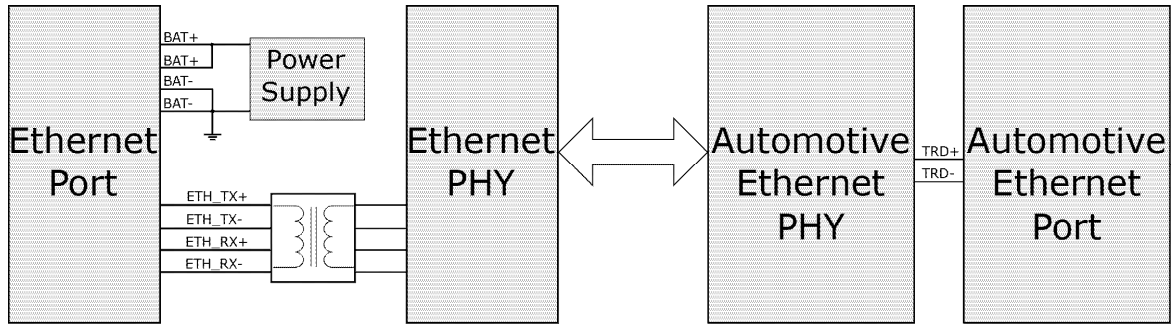

## Technical Specifications:

### Input

Power Supply Input - Nominal	12V, 24Vdc nominal (8...36VDC power supply range)
Protections	Surge and reverse polarity protection are provided. Input overvoltage (37V) and input undervoltage (6V) protection are provided. The unit is designed for 12Vdc based load dump.
Power Consumption	650 mW @ 12 V typical
Power LED	GREEN= Power ON OFF = Power OFF

### Automotive Ethernet

Port Type	1 port 100Mbps 100BASE-T1 full-duplex
PHY Transceiver	Texas Instruments DP83TC811S-Q1
LED's	2 GREEN for Automotive Ethernet  LINK: GREEN means connection (MASTER MODE) YELLOW means connection (SLAVE MODE) OFF means connection is down  Activity: Flashing means activity OFF means connection is down
Protection	ESD and EFT protection for signal lines
Protocol	Automotive Ethernet IEEE 802.3bw

### Ethernet Port

Port Type	1 port 100 Mbit Ethernet compliant 100BASE-Tx
PHY Transceiver	Texas Instruments DP83822I
MDIX	Auto-MDIX
Protocols	Ethernet IEEE 802.3
Protection	ESD and EFT protection for signal lines

## General Specifications

Functionality	Model AX141500-M acts as a master. Model AX141500-S acts as a slave.
Compliance	CE marking
Vibration	Random Vibration: Z-axis tracked vehicle profile (5 hr/axis in all 3 axes) Sinusoidal Component: 8.9 G Sine sweep, 2.5 hr/axis in all 3 axes
Shock	50 g, 5 impacts per test, 6-20 ms impact duration
Operating Conditions	-40 to 80°C (-40 to 176°F)
Storage Temperature	-40 to 85°C (-40 to 185°F)
Protection	IP67
Weight	0.15 lb. (0.068 kg)
Installation	The typical maximum wire harness length for Automotive Ethernet cabling is 15 m.
Enclosure and Dimensions	See dimensional drawing, Figure 2.0 and 3.0. Nylon 6/6, 30% glass fill UL 94V-0 Ultrasonically welded

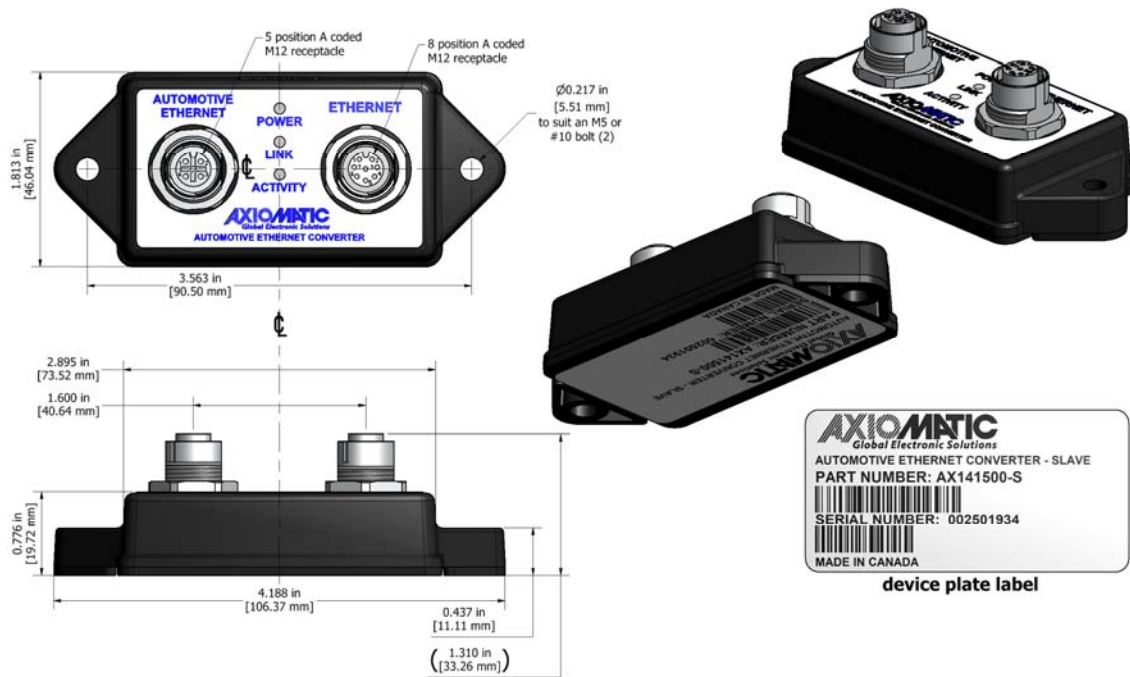

Figure 2.0. Dimensional Drawing – AX141500-S

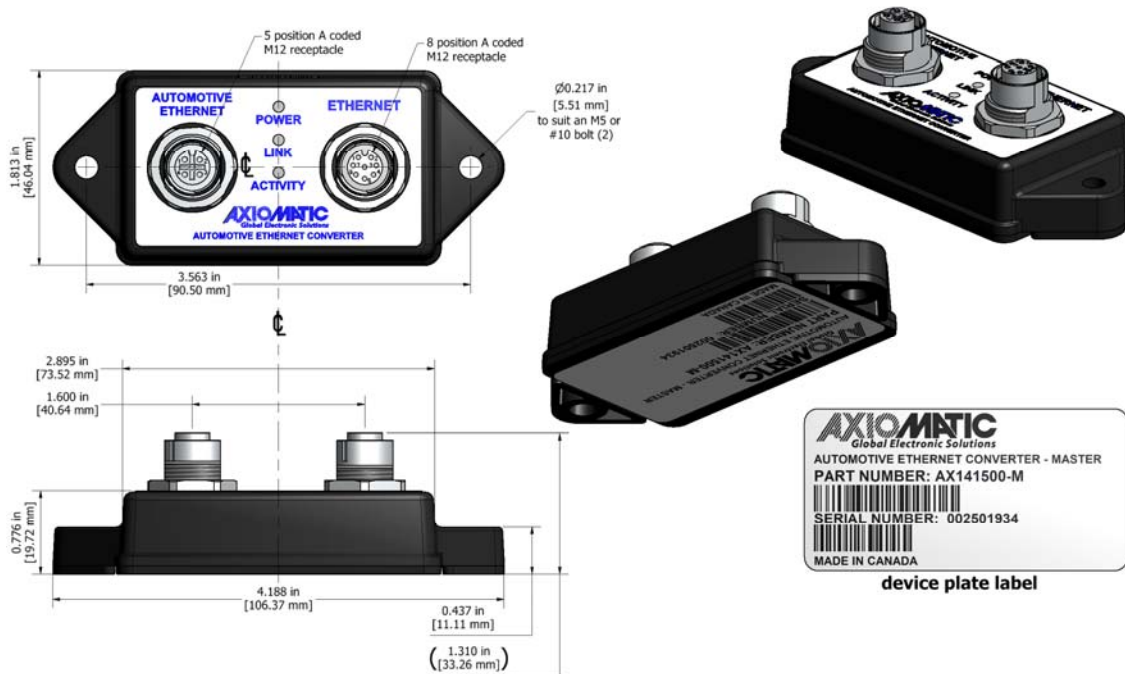
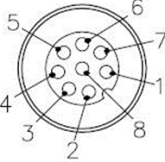
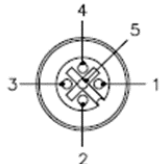

Figure 3.0 Dimensional Drawing – AX141500-M

Electrical Connections	<p>1 Phoenix Contact M12 8-pin connector (A-coded), P/N: 1441817 (Connector 1) Ethernet Port: Power In, Ethernet</p> <table border="1" data-bbox="589 1020 1002 1234"> <thead> <tr> <th>PIN#</th> <th>Description</th> </tr> </thead> <tbody> <tr> <td>1</td> <td>Power IN</td> </tr> <tr> <td>2</td> <td>Power GND</td> </tr> <tr> <td>3</td> <td>Power GND</td> </tr> <tr> <td>4</td> <td>Ethernet TX-</td> </tr> <tr> <td>5</td> <td>Ethernet RX+</td> </tr> <tr> <td>6</td> <td>Ethernet TX+</td> </tr> <tr> <td>7</td> <td>Power IN</td> </tr> <tr> <td>8</td> <td>Ethernet RX-</td> </tr> </tbody> </table>  <p>1 Phoenix Contact M12 5-pin connector (A-coded), P/N: 1441778 (Connector 2) Automotive Ethernet Port: Automotive Ethernet</p> <table border="1" data-bbox="589 1325 1002 1530"> <thead> <tr> <th>PIN#</th> <th>Description</th> </tr> </thead> <tbody> <tr> <td>1</td> <td>TRD-</td> </tr> <tr> <td>2</td> <td>TRD+</td> </tr> <tr> <td>3</td> <td>NC</td> </tr> <tr> <td>4</td> <td>NC</td> </tr> <tr> <td>5</td> <td>NC</td> </tr> </tbody> </table> 	PIN#	Description	1	Power IN	2	Power GND	3	Power GND	4	Ethernet TX-	5	Ethernet RX+	6	Ethernet TX+	7	Power IN	8	Ethernet RX-	PIN#	Description	1	TRD-	2	TRD+	3	NC	4	NC	5	NC
PIN#	Description																														
1	Power IN																														
2	Power GND																														
3	Power GND																														
4	Ethernet TX-																														
5	Ethernet RX+																														
6	Ethernet TX+																														
7	Power IN																														
8	Ethernet RX-																														
PIN#	Description																														
1	TRD-																														
2	TRD+																														
3	NC																														
4	NC																														
5	NC																														
Mating Connectors	<p>Mating connectors should meet the following standard for M12 Connectors, IEC 61076-2-101:2012. They should be A-coded. Phoenix SACC-M12MS-5PL SH – 1424658 supports 26 – 18 AWG wiring.</p>																														
Mating Wire Harnesses	<p>The following part numbers are available from Axiomatic. <b>AX070531</b> Ethernet and Power Cable - 1.7m (5.5 ft.), 8-pin M12 A-coded, Unterminated Leads, Partially Shielded, Ethernet Jack <b>AX070532</b> CAN Cable - 1.5 m (5 ft.), 5-pin M12 A-coded, Unterminated Leads, Shielded</p>																														

Specifications are indicative and subject to change. Actual performance will vary depending on the application and operating conditions. Users should satisfy themselves that the product is suitable for use in the intended application. All our products carry a limited warranty against defects in material and workmanship. Please refer to our Warranty, Application Approvals/Limitations and Return Materials Process as described on [www.axiomatic.com/service.html](http://www.axiomatic.com/service.html).

Form: TDAX141500-12/20/21