

**TECHNICAL DATASHEET #TDAX189000**  
**Thermocouple Module, 1 Channel**  
**P/N: AX189000**

**Monitors 1 Type J, K, B, E, N, R, S or T Thermocouples**  
**2 Universal Signal Inputs**  
**2 CAN (SAE J1939)**  
**with Electronic Assistant**

**Description:**

Two universal signal inputs are configurable as: Voltage, Current, PWM, Digital or Resistive (for Input 1 only). The Thermocouple Module monitors 1 channel of Type J, K, B, E, N, R, S or T thermocouples (others on request). The temperature information is provided to the engine control system over SAE J1939 CAN bus. Temperature information can include exhaust temperature, winding temperature, and fluid temperature monitoring. All channels are fully isolated and measure temperatures at the same time. Temperature data is automatically sent over the CAN bus when power is applied. The input is isolated. During set-up, using an USB-CAN converter and a PC, the operator can configure the controller via the Axiomatic Electronic Assistant to suit a wide variety of applications. Integral diagnostics can flag open wire fault detection. CAN communications are via an isolated CAN interface with SAE J1939 protocol. Settings are automatically saved to non-volatile memory. The product enclosure is rated as IP67 and has a 12 pin Deutsch style connector.



**Applications:**

- Applications include power generator sets.
- Machine engine monitoring systems

**Features:**

- 2 Universal signal inputs configurable as: Voltage, Current, PWM, Digital or Resistive (for Input 1 only).
- Reads 1 Type J, K, B, E, N, R, S or T thermocouple input (other thermocouple types on request)
- TC input channel configured for SAE J1939 SPN to transmit the temperature measured by that input
- User defined SPN configurability
- Cold junction compensation is provided.
- Thermocouple input resolution is 0.1 °C.
- Accuracy is +/-1 °C throughout the entire range of the thermocouple input.
- Full channel to channel isolation and isolation from CAN line, TC input and power supply
- 2 CAN (SAE J1939) ports with auto-baud-rate detection
- Robust 9...60Vdc power supply, 12V, 24V or 48Vdc nominal, with reverse polarity protection
- Compact size for mounting directly on the power generator set or remotely
- Rugged IP67 rated packaging with 12 pin plug-in connection
- Operational from -40 to 70°C (-40 to 158°F)
- **Electronic Assistant** configuration
- Configuration files can be saved and written to other same devices during setup.

**Ordering Part Numbers:**

Thermocouple Module, 1 TC, 2 Universal Signal, 2 SAE J1939, Auto-baud-rate Detect: **AX189000**  
Thermocouple Module, 1 TC, 2 Universal Signal, 2 CANopen®: **AX189001**

**Accessories:**

**PL-DTM06-12SA** Mating Plug Kit :1 DTM06-12SA, 1 WM-12S, 12 0462-201-20141, 6 0413-204-2005  
Sealing Plug

Electronic Assistant Configuration Kit: **AX070502** or **AX070505K**

## Block Diagram

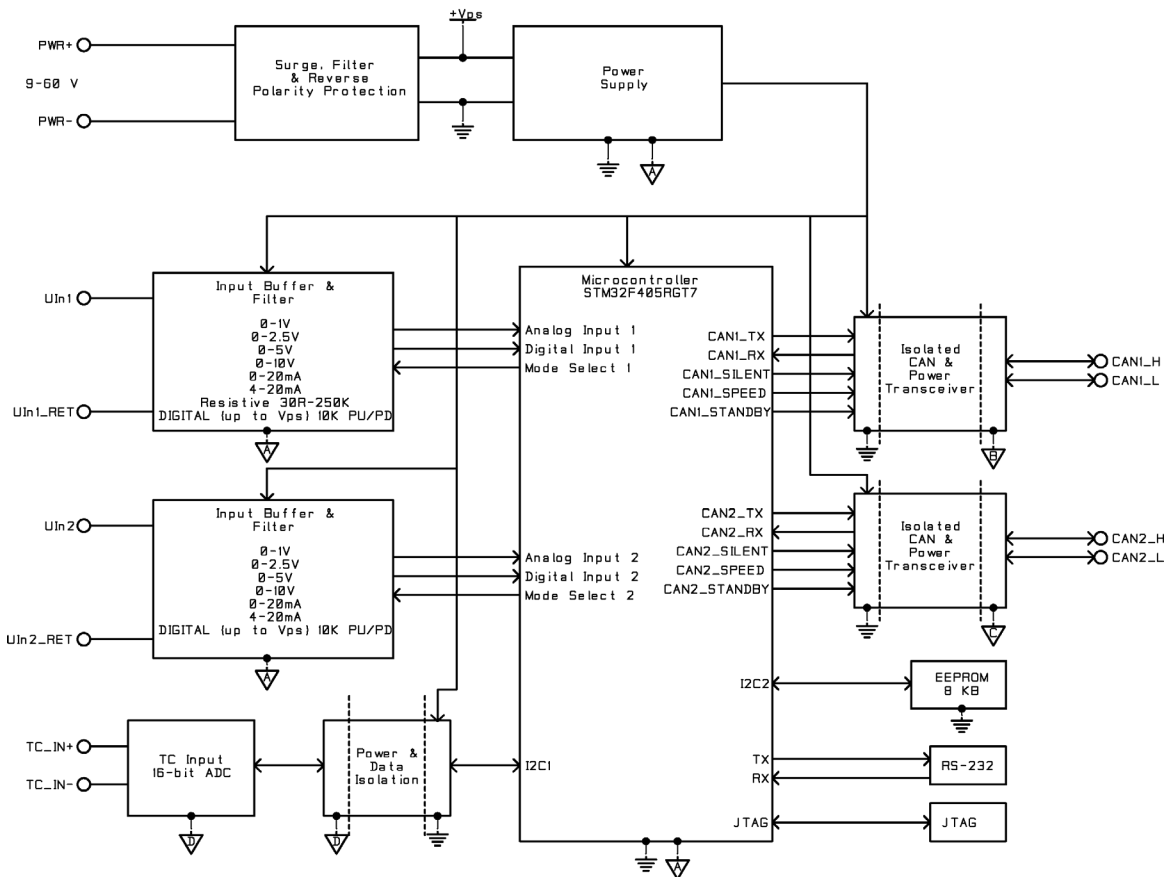

## Technical Specifications:

Specifications are indicative and subject to change. Actual performance will vary depending on the application and operating conditions. Users should satisfy themselves that the product is suitable for use in the intended application. All our products carry a limited warranty against defects in material and workmanship. Please refer to our Warranty, Application Approvals/Limitations and Return Materials Process as described on <https://www.axiomatic.com/service/>.

## Power Supply:

Power Supply Input	12V, 24V or 48Vdc nominal (9...60Vdc power supply range)
Surge and Transients	Surge and transient protection up to 120 V is provided.
Reverse Polarity	Reverse polarity protection is provided up to 100V.
Under-voltage	Under-voltage protection is provided. Hardware shuts down at 5V.
Over-voltage	Over-voltage protection is provided. Hardware shuts down at 62 V.

## Input Specifications

Universal Inputs	2 Universal Signal Inputs configurable as: Voltage, Current, PWM, Digital or Resistive (for Input 1 only) Refer to Table 1.0.
------------------	--

TC Input	<p>One (1) Type J, K, B, E, N, R, S or T  The device reads mV signals from the supported Thermocouples.  B = 0 to 13.82 mV  E = -9.835 to 76.373 mV  J = -8.095 to 69.553 mV  K = -6.458 to 54.886 mV  N = -4.345 to 47.513 mV  R = -0.226 to 21.101 mV  S = -0.236 to 18.693 mV  T = -6.258 to 20.872 mV  (Other TC types are available on request.)</p>
Resolution	<p>Temperature data is measured with a resolution of 0.1 °C.  When sending data to the J1939 bus, one-byte parameters have a resolution of 1°C/ bit, an offset of -40°C and a range of -40 °C to 210 °C. Two-byte parameters have resolution of 0.03125 °C / bit and a range of -273 °C to 1735 °C.</p>
Drift	Overall drift with temperature is 50ppm/°C of span (maximum).
Accuracy	+/-1 °C throughout the entire range of the thermocouple input
Input Functionality	<p>Temperature is measured in °C with a 0.1°C resolution. All inputs send a message to the J1939 bus.  There are 2 setpoints for the TC input channel. The TC input channel is configured to indicate the SAE J1939 SPN to transmit the temperature measured by that input. The Parameter Group Number (PGN) that will be used to send a temperature to the J1939 network is dependent on the Suspect Parameter Number (SPN) that was selected for that channel. Refer to Table 2.0 for a list of supported SPN's. Regardless of the SPN selected, temperature is always available for the associated PGN. The controller supports all the temperature SPNs as defined in J1939-71 as of January 2009. In order to allow for future expansion, the user can select a "User Defined" SPN (0) which enables a variety of setpoints associated with transmitting the data on the network. This allows the user to select the PGN, size (1 or 2 bytes), data index and repetition rate of the message that will broadcast the temperature for the TC input channel.  <i>To use the J1939 capabilities, refer to the user manual for details.</i></p>
Measurement Rate	<p>The measurement rate is 5 scans/Sec. All channels are measured simultaneously.  The update rate is 200 mSec.</p>
Common Mode	<p>Common mode rejection is &gt;110 db@ 5V p-p (programmable for either 50 or 60 Hz).  Common mode input range is +/- 4 V minimum.</p>
Ground	2 analog ground connections are provided.

Table 1.0: Universal Inputs

Parameter	Value				
Universal Inputs	Two (2) Universal Signal Inputs are provided. Configurable as: Voltage, Current, PWM, Digital or Resistive (for Input 1 only)				
Analog Input Modes	Voltage, Current, Resistance 12-bit Analog to Digital				
Voltage Input	Input Range	Input Impedance	Resolution	Accuracy	
	0...1V	>1 MOhm (High Z) <sup>1</sup>	1 mV	+/- 1%	
	0...2.5V	>1 MOhm (High Z) <sup>1</sup>	1 mV	+/- 1%	
	0...5V	204 kOhm <sup>1</sup>	1 mV	+/- 1%	
	0...10V	136 kOhm <sup>1</sup>	1 mV	+/- 1%	
<sup>1</sup> 10kOhm LoZ option is available.					
Current Input	Input Range	Input Impedance	Resolution	Accuracy	
	0...20mA	124Ohm	<12uA	+/- 1%	
	4...20mA				
Resistive Input	<b>The Resistive Input is only available on Universal Input 1.</b>				
	Input Range	Resolution	Accuracy		
	Auto Range 10...250kOhm <sup>1,2</sup>	–	–		
	30Ohm...250kOhm <sup>2</sup>	<0.15 Ohm	+/- 2%		
<sup>1</sup> Resolution and accuracy depend on the automatically selected Input Range. <sup>2</sup> Resistance <10 Ohm is measured as 0.					
Analog Update Rate	1ms minimum <sup>1</sup> . <sup>1</sup> Depends on the analog filter settings. In resistive mode also depends on the number of resistive inputs.				
Digital Input Modes	Discrete Voltage Level, Frequency, PWM Duty Cycle				
Input Polarity	Active High up to 5.5V, Active Low to Ground				
Input Amplitude	0V to +Vps				
Input Impedance	>1MOhm – High Z, 10kOhm pull down, 10kOhm pull-up to +5.5V				
Input Level	5V CMOS Compatible. A direct connection to the power supply is acceptable.				
Discrete Voltage Level Input	1ms sampling rate				
Frequency Input	Input Number	Counter Resolution	Frequency Range	Resolution	Accuracy
	Universal Input #1...2	16-bit	100Hz...10kHz	<0.0015...0.15%	+/- 1%
			10Hz...1kHz		
			1Hz...100Hz		
PWM Duty Cycle Input	Input Number	Counter Resolution	Frequency Range	Resolution	Accuracy
Universal Input #1...2	16-bit	100Hz...10kHz	<0.0015...0.15%	+/- 1%	
				10Hz...1kHz	+/- 1%
				1Hz...100Hz	+/- 1%
0...100% Duty Cycle Range. DC is included.					
Protection	+36V maximum. Forward voltage only. No reverse polarity protection. Protected against shorts to GND or +Supply				

## Control Logic:

Software Platform	Pre-programmed with standard logic. Refer to the user manual. (Application-specific control logic is available on request.)
Function Blocks	For more details on control logic, refer to the User Manual. Setpoint configuration files can be saved and used to program additional controllers.
FMI	There are four FMIs associated with the thermocouple input channel and include the following functions: High Temperature Shutdown; High Temperature Warning; Low Temperature Warning; and Thermocouple Open Circuit.
Diagnostics	The controller stores diagnostic data in a non-volatile log. There are four diagnostic log entries associated with each input channel. Each entry is a record of the SPN, FMI and OC for any fault that has occurred. There are eight setpoints associated with if and how the ECU will send diagnostic messages for each channel. For more details refer to the user manual.

Table 2.0: Supported Suspect Parameter Numbers

SPN	Description	Size	PGN	Rate	Index	Priority
52	Engine Intercooler Temperature	1	65262	1000	7	6
75	Steering Axle Temperature	1	65273	1000	1	6
79	Road Surface Temperature	2	65269	1000	7	6
90	Power Takeoff Oil Temperature	1	65264	100	1	6
105	Engine Intake Manifold 1 Temperature	1	65270	500	3	6
110	Engine Coolant Temperature	1	65262	1000	1	6
120	Hydraulic Retarded Oil Temperature	1	65275	1000	2	6
169	Cargo Ambient Temperature	2	65276	1000	5	6
170	Cab Interior Temperature	2	65269	1000	2	6
171	Ambient Air Temperature	2	65269	1000	4	6
172	Engine Air Inlet Temperature	1	65269	1000	6	6
173	Engine Exhaust Gas Temperature	2	65270	500	6	6
174	Engine Fuel Temperature 1	1	65262	1000	2	6
175	Engine Oil Temperature 1	2	65262	1000	3	6
176	Engine Turbocharger Oil Temperature	2	65262	1000	5	6
177	Transmission Oil Temperature	2	65272	1000	5	6
242	Tire Temperature	2	65268	1000 0	3	6
412	Engine Exhaust Gas Recirculation 1 Temperature	2	65188	1000	7	6
441	Auxiliary Temperature 1	1	65164	0	1	7
442	Auxiliary Temperature 2	1	65164	0	2	7
578	Drive Axle Temperature	1	65273	1000	4	6
1122	Engine Alternator Bearing 1 Temperature	1	65191	1000	1	7
1123	Engine Alternator Bearing 2 Temperature	1	65191	1000	2	7
1124	Engine Alternator Winding 1 Temperature	1	65191	1000	3	7
1125	Engine Alternator Winding 2 Temperature	1	65191	1000	4	7
1126	Engine Alternator Winding 3 Temperature	1	65191	1000	5	7
1131	Engine Intake Manifold 2 Temperature	1	65189	500	1	6
1132	Engine Intake Manifold 3 Temperature	1	65189	500	2	6
1133	Engine Intake Manifold 4 Temperature	1	65189	500	3	6
1135	Engine Oil Temperature 2	2	65188	1000	1	6
1136	Engine ECU Temperature	2	65188	1000	3	6
1137	Engine Exhaust Gas Port 1 Temperature	2	65187	1000	1	6
1138	Engine Exhaust Gas Port 2 Temperature	2	65187	1000	3	6
1139	Engine Exhaust Gas Port 3 Temperature	2	65187	1000	5	6

1140	Engine Exhaust Gas Port 4 Temperature	2	65187	1000	7	6
1141	Engine Exhaust Gas Port 5 Temperature	2	65186	1000	1	6
1142	Engine Exhaust Gas Port 6 Temperature	2	65186	1000	3	6
1143	Engine Exhaust Gas Port 7 Temperature	2	65186	1000	5	6
1144	Engine Exhaust Gas Port 8 Temperature	2	65186	1000	7	6
1145	Engine Exhaust Gas Port 9 Temperature	2	65185	1000	1	6
1146	Engine Exhaust Gas Port 10 Temperature	2	65185	1000	3	6
1147	Engine Exhaust Gas Port 11 Temperature	2	65185	1000	5	6
1148	Engine Exhaust Gas Port 12 Temperature	2	65185	1000	7	6
1149	Engine Exhaust Gas Port 13 Temperature	2	65184	1000	1	6
1150	Engine Exhaust Gas Port 14 Temperature	2	65184	1000	3	6
1151	Engine Exhaust Gas Port 15 Temperature	2	65184	1000	5	6
1152	Engine Exhaust Gas Port 16 Temperature	2	65184	1000	7	6
1153	Engine Exhaust Gas Port 17 Temperature	2	65183	1000	1	6
1154	Engine Exhaust Gas Port 18 Temperature	2	65183	1000	3	6
1155	Engine Exhaust Gas Port 19 Temperature	2	65183	1000	5	6
1156	Engine Exhaust Gas Port 20 Temperature	2	65183	1000	7	6
1157	Engine Main Bearing 1 Temperature	2	65182	1000	1	6
1158	Engine Main Bearing 2 Temperature	2	65182	1000	3	6
1159	Engine Main Bearing 3 Temperature	2	65182	1000	5	6
1160	Engine Main Bearing 4 Temperature	2	65182	1000	7	6
1161	Engine Main Bearing 5 Temperature	2	65181	1000	1	6
1162	Engine Main Bearing 6 Temperature	2	65181	1000	3	6
1163	Engine Main Bearing 7 Temperature	2	65181	1000	5	6
1164	Engine Main Bearing 8 Temperature	2	65181	1000	7	6
1165	Engine Main Bearing 9 Temperature	2	65180	1000	1	6
1166	Engine Main Bearing 10 Temperature	2	65180	1000	3	6
1167	Engine Main Bearing 11 Temperature	2	65180	1000	5	6
1172	Engine Turbocharger 1 Compressor Inlet Temperature	2	65178	1000	1	6
1173	Engine Turbocharger 2 Compressor Inlet Temperature	2	65178	1000	3	6
1174	Engine Turbocharger 3 Compressor Inlet Temperature	2	65178	1000	5	6
1175	Engine Turbocharger 4 Compressor Inlet Temperature	2	65178	1000	7	6
1180	Engine Turbocharger 1 Turbine Inlet Temperature	2	65176	1000	1	6
1181	Engine Turbocharger 2 Turbine Inlet Temperature	2	65176	1000	3	6
1182	Engine Turbocharger 3 Turbine Inlet Temperature	2	65176	1000	5	6
1183	Engine Turbocharger 4 Turbine Inlet Temperature	2	65176	1000	7	6
1184	Engine Turbocharger 1 Turbine Outlet Temperature	2	65175	1000	1	6
1185	Engine Turbocharger 2 Turbine Outlet Temperature	2	65175	1000	3	6
1186	Engine Turbocharger 3 Turbine Outlet Temperature	2	65175	1000	5	6
1187	Engine Turbocharger 4 Turbine Outlet Temperature	2	65175	1000	7	6
1212	Engine Auxiliary Coolant Temperature	1	65172	500	2	6
1636	Engine Intake Manifold 1 Air Temperature (High Resolution)	2	65129	1000	1	6
1637	Engine Coolant Temperature (High Resolution)	2	65129	1000	3	6
1638	Hydraulic Temperature	1	65128	1000	1	6
1687	Auxiliary Heater Outlet Coolant Temperature	1	65133	1000	1	6
1688	Auxiliary Heater Input Air Temperature	1	65133	1000	2	6
1800	Battery 1 Temperature	1	65104	1000	1	6
1801	Battery 2 Temperature	1	65104	1000	2	6

1802	Engine Intake Manifold 5 Temperature	1	65189	500	4	6
1803	Engine Intake Manifold 6 Temperature	1	65189	500	5	6
2433	Engine Exhaust Gas Temperature - Right Manifold	2	65031	500	1	6
2434	Engine Exhaust Gas Temperature - Left Manifold	2	65031	500	3	6
2629	Engine Turbocharger 1 Compressor Outlet Temperature	2	64979	1000	1	6
2630	Engine Charge Air Cooler 1 Outlet Temperature	2	65129	1000	7	6
2799	Engine Turbocharger 2 Compressor Outlet Temperature	2	64979	1000	3	6
2800	Engine Turbocharger 3 Compressor Outlet Temperature	2	64979	1000	5	6
2801	Engine Turbocharger 4 Compressor Outlet Temperature	2	64979	1000	7	6
2986	Engine Intake Valve Actuation System Oil Temperature	2	65129	1000	5	6
3031	Aftertreatment 1 SCR Catalyst Tank Temperature	1	65110	1000	2	6
3241	Aftertreatment 1 Exhaust Gas Temperature 1	2	64948	500	1	6
3242	Aftertreatment 1 Diesel Particulate Filter Intake Gas Temperature	2	64948	500	3	6
3245	Aftertreatment 1 Exhaust Gas Temperature 3	2	64947	500	1	6
3246	Aftertreatment 1 Diesel Particulate Filter Outlet Gas Temperature	2	64947	500	3	6
3249	Aftertreatment 1 Exhaust Gas Temperature 2	2	64946	500	1	6
3250	Aftertreatment 1 Diesel Particulate Filter Intermediate Gas Temperature	2	64946	500	3	6
3275	Aftertreatment 2 Exhaust Gas Temperature 1	2	64945	500	1	6
3276	Aftertreatment 2 Diesel Particulate Filter Intake Gas Temperature	2	64945	500	3	6
3279	Aftertreatment 2 Exhaust Gas Temperature 3	2	64944	500	1	6
3280	Aftertreatment 2 Diesel Particulate Filter Outlet Gas Temperature	2	64944	500	3	6
3283	Aftertreatment 2 Exhaust Gas Temperature 2	2	64943	500	1	6
3284	Aftertreatment 2 Diesel Particulate Filter Intermediate Gas Temperature	2	64943	500	3	6
3468	Engine Fuel Temperature 2	1	64930	500	5	4
3515	Aftertreatment 1 SCR Catalyst Reagent Temperature 2	1	64923	1000	1	6
3823	Transmission Torque Converter Oil Outlet Temperature	2	64917	1000	2	6
3831	Aftertreatment 1 Secondary Air Temperature	2	64877	500	3	6
3834	Aftertreatment 2 Secondary Air Temperature	2	64876	500	3	6
4076	Engine Coolant Temperature 2	1	64870	1000	1	6
4151	Engine Exhaust Gas Temperature Average	2	64851	500	1	5
4152	Engine Exhaust Gas Temperature Average - Bank 2	2	64851	500	3	5
4153	Engine Exhaust Gas Temperature Average - Bank 1	2	64851	500	5	5
4193	Engine Coolant Pump Outlet Temperature	1	64870	1000	2	6
4288	Engine Exhaust Valve Actuation System Oil Temperature	2	64870	1000	4	6
4289	Aftertreatment 1 Three Way Catalytic Converter Intake Gas Temperature	2	64838	500	1	6
4290	Aftertreatment 1 Three Way Catalytic Converter Outlet Gas Temperature	2	64838	500	3	6
4295	Aftertreatment 2 Three Way Catalytic Converter Intake Gas Temperature	2	64837	500	1	6
4296	Aftertreatment 2 Three Way Catalytic Converter Outlet Gas Temperature	2	64837	500	3	6
4337	Aftertreatment 1 SCR Dosing Reagent Temperature	1	64833	500	3	6
4360	Aftertreatment 1 SCR Catalyst Intake Gas Temperature	2	64830	500	1	6
4363	Aftertreatment 1 SCR Catalyst Outlet Gas Temperature	2	64830	500	4	6
4368	Aftertreatment 1 SCR Catalyst Reagent Tank 2 Temperature	1	64829	1000	2	6
4390	Aftertreatment 2 SCR Dosing Reagent Temperature	1	64827	500	3	6
4413	Aftertreatment 2 SCR Catalyst Intake Gas Temperature	2	64824	500	1	6

4415	Aftertreatment 2 SCR Catalyst Outlet Gas Temperature	2	64824	500	4	6
4420	Aftertreatment 2 SCR Catalyst Reagent Temperature 2	1	64822	1000	1	6
4427	Aftertreatment 2 SCR Catalyst Tank Temperature	1	64821	1000	2	6
4434	Aftertreatment 2 SCR Catalyst Reagent Tank 2 Temperature	1	64820	1000	2	6
4750	Engine Exhaust Gas Recirculation 1 (EGR1) Cooler Intake Temperature	2	64879	0	3	6
4753	Aftertreatment 1 Gas Oxidation Catalyst Intake Gas Temperature	2	64802	500	1	6
4754	Aftertreatment 1 Gas Oxidation Catalyst Outlet Gas Temperature	2	64802	500	3	6
4759	Aftertreatment 2 Gas Oxidation Catalyst Intake Gas Temperature	2	64801	500	1	6
4760	Aftertreatment 2 Gas Oxidation Catalyst Outlet Gas Temperature	2	64801	500	3	6
4765	Aftertreatment 1 Diesel Oxidation Catalyst Intake Gas Temperature	2	64800	500	1	6
4766	Aftertreatment 1 Diesel Oxidation Catalyst Outlet Gas Temperature	2	64800	500	3	6
4771	Aftertreatment 2 Diesel Oxidation Catalyst Intake Gas Temperature	2	64799	500	1	6
4772	Aftertreatment 2 Diesel Oxidation Catalyst Outlet Gas Temperature	2	64799	500	3	6
4809	Aftertreatment 1 Warm Up Diesel Oxidation Catalyst Intake Temperature	2	64794	500	1	6
4810	Aftertreatment 1 Warm Up Diesel Oxidation Catalyst Outlet Temperature	2	64794	500	3	6
5020	Engine Exhaust Gas Recirculation 1 (EGR1) Mixer Intake Temperature	2	64870	1000	6	6
5148	Low Voltage Disconnect Temperature	1	64769	500	4	6
5255	Engine Exhaust Gas Recirculation 2 (EGR2) Temperature	2	64767	1000	1	6
5256	Engine Exhaust Gas Recirculation 2 (EGR2) Mixer Intake Temperature	2	64767	1000	3	6
5258	Engine Exhaust Gas Recirculation 2 (EGR2) Cooler Intake Temperature	2	64766	0	1	6
5280	Engine Charge Air Cooler 1 Precooler Intake Temperature	2	64759	1000	1	6
5281	Engine Charge Air Cooler 1 Precooler Outlet Temperature	2	64759	1000	3	6
5283	Engine Charge Air Cooler 1 Intake Temperature	2	64758	1000	1	6
5284	Engine Charge Air Cooler 1 Ambient Air Temperature	2	64758	1000	3	6
5286	Engine Charge Air Cooler 2 Precooler Intake Temperature	2	64757	1000	1	6
5287	Engine Charge Air Cooler 2 Precooler Outlet Temperature	2	64757	1000	3	6
5289	Engine Charge Air Cooler 2 Intake Temperature	2	64756	1000	1	6
5290	Engine Charge Air Cooler 2 Outlet Temperature	2	64756	1000	3	6
5291	Engine Charge Air Cooler 2 Ambient Air Temperature	2	64756	1000	5	6
5315	Aftertreatment 2 Warm Up Diesel Oxidation Catalyst Intake Temperature	2	64749	500	1	6
5316	Aftertreatment 2 Warm Up Diesel Oxidation Catalyst Outlet Temperature	2	64749	500	3	6
5456	Aftertreatment 1 Hydrocarbon Doser Intake Fuel Temperature	1	64869	500	6	6

**General Specifications:**

Microprocessor	STM32F405RG, 32-bit, 1MByte flash memory
Quiescent Current	39mA at 24V, 76mA at 12V
Isolation	Isolation of TC input channel and the CAN ports from the other inputs and power supply. 330 Vrms for the CAN port 445 Vrms for the TC input
CAN Interface	2 Isolated CAN ports (SAE J1939) (CANopen® model is AX189001) The software was designed to provide flexibility and provides the following. <ul style="list-style-type: none"> <li>Configurable ECU Instance in the NAME (for multiple ECU's on the network)</li> </ul>

	<ul style="list-style-type: none"> <li>Configurable SPN for each channel</li> <li>Configurable Diagnostic Messaging Parameters, as required</li> <li>Diagnostic Log, maintained in non-volatile memory</li> </ul> <p><i>Note: Configurable parameters are also called setpoints.</i></p>																										
Baud Rate	SAE J1939, 250kbit/s, 500kbit/s, 667kbit/s, 1Mbit/s. Automatic Baud Rate Detection																										
Protection for CAN port	CAN transceivers provide a 115 mA short circuit current limit																										
User Interface	AX070502 Electronic Assistant KIT includes the USB-CAN Converter, cables and EA Software. The Electronic Assistant is for <i>Windows</i> operating systems. It comes with a royalty-free license for use.																										
Reflashing Software over CAN	Reflash software over the CAN bus per the SAE J1939 standard using the Electronic Assistant.																										
Enclosure and Dimensions	Molded Enclosure, integral connector Nylon 6/6, 30% glass Ultrasonically welded 3.54 x 2.75 x 1.31 inches (90.09 x 70.00 x 33.35 mm) L x W x H including integral connector Refer to the dimensional drawing.																										
Electrical Connections	Integral TE Deutsch 12 pin receptacle (P/N: DTM04-12PA) <table border="1" data-bbox="479 751 928 1136"> <thead> <tr> <th>PIN #</th> <th>FUNCTION</th> </tr> </thead> <tbody> <tr> <td>1</td> <td>Universal Input 1 GND</td> </tr> <tr> <td>2</td> <td>Universal Input 1</td> </tr> <tr> <td>3</td> <td>Universal Input 2</td> </tr> <tr> <td>4</td> <td>Universal Input 2 GND</td> </tr> <tr> <td>5</td> <td>TC Input</td> </tr> <tr> <td>6</td> <td>TC Input Return</td> </tr> <tr> <td>7</td> <td>CAN 2_L</td> </tr> <tr> <td>8</td> <td>CAN 2_H</td> </tr> <tr> <td>9</td> <td>CAN 1_L</td> </tr> <tr> <td>10</td> <td>CAN 1_H</td> </tr> <tr> <td>11</td> <td>Power -</td> </tr> <tr> <td>12</td> <td>Power +</td> </tr> </tbody> </table>	PIN #	FUNCTION	1	Universal Input 1 GND	2	Universal Input 1	3	Universal Input 2	4	Universal Input 2 GND	5	TC Input	6	TC Input Return	7	CAN 2_L	8	CAN 2_H	9	CAN 1_L	10	CAN 1_H	11	Power -	12	Power +
PIN #	FUNCTION																										
1	Universal Input 1 GND																										
2	Universal Input 1																										
3	Universal Input 2																										
4	Universal Input 2 GND																										
5	TC Input																										
6	TC Input Return																										
7	CAN 2_L																										
8	CAN 2_H																										
9	CAN 1_L																										
10	CAN 1_H																										
11	Power -																										
12	Power +																										
Mating Plug Kit	Mates to PL-DTM06-12SA (1 DTM06-12SA, 1 WM-12S, 10 0462-201-20141, 2 0413-204-2005 Sealing Plug)																										
Operating Conditions	-40 to 70°C (-40 to 158°F)																										
Weight	0.14 lb. (0.064 kg)																										
Protection	IP67; Unit is conformal coated within the housing.																										
Vibration	MIL-STD-202G, Test 204D and 214A (Sine and Random) 10 g peak (Sine) 7.65 Grms peak (Random)																										
Shock	MIL-STD-202G, Test 213B 50 g																										
Mounting	<p>Mounting holes are sized for #8 or M4 bolts. The bolt length will be determined by the end-user's mounting plate thickness. The mounting flange of the controller is 0.425 inches (10.8 mm) thick.</p> <p>If the module is mounted without an enclosure, it should be mounted vertically with connectors facing left or right to reduce likelihood of moisture entry.</p> <p>The CAN wiring is considered intrinsically safe. The power wires are not considered intrinsically safe and so in hazardous locations, they need to be located in conduit or conduit trays at all times. The module must be mounted in an enclosure in hazardous locations for this purpose.</p> <p>No wire or cable harness should exceed 30 meters in length. The power input wiring should be limited to 10 meters.</p> <p>All field wiring should be suitable for the operating temperature range.</p> <p>Install the unit with appropriate space available for servicing and for adequate wire harness access (6 inches or 15 cm) and strain relief (12 inches or 30 cm).</p>																										

ISO 11898	120Ohm terminated twisted pair, baud rate up to 1Mbit/s. External 120Ohm termination is required.
-----------	--

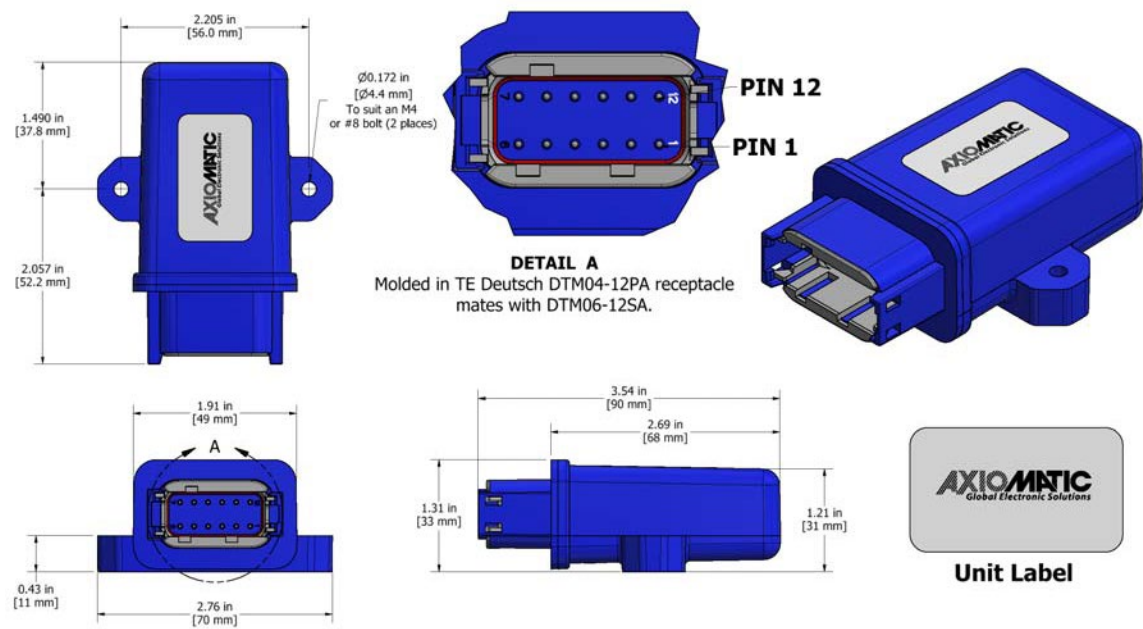

Figure 1.0 - Dimensional Drawing

Note: CANopen® is a registered community trademark of CAN in Automation e.V.

Form: TDAX189000-07/18/22