



USER MANUAL UMAX021210
USER MANUAL UMAX021210-01
USER MANUAL UMAX021210-02

10 OUTPUT VALVE CONTROLLER WITH CAN, SAE J1939

USER MANUAL

P/N: AX021210

P/N: AX021210-01 – J1939 500kbits/s Baud Rate

P/N: AX021210-02 – Custom J1939 Baud Rate, 1Mbits/s

In Europe:
Axiomatic Technologies Oy
Höytämöntie 6
33880 LEMPÄÄLÄ - Finland
Tel. +358 103 375 750
Fax. +358 3 3595 660
www.axiomatic.fi

In North America:
Axiomatic Technologies Corporation
5915 Wallace Street
Mississauga, ON Canada L4Z 1Z8
Tel. 1 905 602 9270
Fax. 1 905 602 9279
www.axiomatic.com

VERSION HISTORY

Version	Date	Author	Modification
1.0.0.	July 21, 2014	Ilona Korpelainen	Initial Draft
-	July 23, 2014	Amanda Wilkins	Marketing Review
1.0.1.	March 2, 2015	Antti Keränen	P/Ns AX021210-01 and AX021210-02 added. P/N table added to page 6. EA configuration note added to page 22.
1.0.2	July 31, 2015	Amanda Wilkins	CE mark
1.0.3	December 24, 2015	Ilona Korpelainen	Updated to reflect new diagnostics, CAN Receive acknowledge setpoint added, Output Current Regulator Parameters added.
-	March 2, 2017	Ilona Korpelainen	Updated EA version number
-	July 30, 2020	Amanda Wilkins	Updated power supply range to 9...40V Added dimensional drawing Rev A for AX021210

ACRONYMS

ACK	Positive Acknowledgement (from SAE J1939 standard)
BATT +/-	Battery positive (a.k.a. Vps) or Battery Negative (a.k.a. GND)
DIN	Digital Input used to measure active high or low signals
DM	Diagnostic Message (from SAE J1939 standard)
DTC	Diagnostic Trouble Code (from SAE J1939 standard)
EA	Electronic Assistant ^{EA} , p/n AX070502 (A Service Tool for Axiomatic ECUs)
ECU	Electronic Control Unit (from SAE J1939 standard)
GND	Ground reference (a.k.a. BATT-)
I/O	Inputs and Outputs
MAP	Memory Access Protocol
NAK	Negative Acknowledgement (from SAE J1939 standard)
PDU1	A format for messages that are to be sent to a destination address, either specific or global (from SAE J1939 standard)
PDU2	A format used to send information that has been labeled using the Group Extension technique, and does not contain a destination address.
PGN	Parameter Group Number (from SAE J1939 standard)
PropA	Message that uses the Proprietary A PGN for peer-to-peer communication
PropB	Message that uses a Proprietary B PGN for broadcast communication
PWM	Pulse Width Modulation
RPM	Rotations per Minute
SPN	Suspect Parameter Number (from SAE J1939 standard)
TP	Transport Protocol
UIN	Universal input used to measure voltage, current, frequency or digital inputs
Vps	Voltage Power Supply (a.k.a. BATT+)
%dc	Percent Duty Cycle (Measured from a PWM input)

TABLE OF CONTENTS

1. OVERVIEW OF CONTROLLER	7
1.1. Output Function Blocks.....	8
1.2. Diagnostic Function Blocks	12
1.3. PID Control Function Block	16
1.4. Lookup Table Function Block	17
1.5. Programmable Logic Function Block.....	18
1.6. Math Function Block	19
1.7. DTC React.....	20
1.8. CAN Transmit Message Function Block.....	20
1.8.1. CAN Transmit Message Setpoints	21
1.8.2. CAN Transmit Signal Setpoints	21
1.9. CAN Receive Function Block	21
1.10. Available Control Sources	22
2. INSTALLATION INSTRUCTIONS	25
2.1. Dimensions and Pinout.....	25
3. OVERVIEW OF J1939 FEATURES	26
3.1. Introduction to Supported Messages.....	26
3.2. NAME, Address and Software ID	27
4. ECU SETPOINTS ACCESSED WITH ELECTRONIC ASSISTANT	29
4.1. Accessing the ECU Using EA.....	29
4.2. J1939 Network Parameters	30
4.3. Output Current Regulator Parameters.....	30
4.4. Proportional Output Setpoints	32
4.5. Constant Data List	33
4.6. PID Control	34
4.7. Lookup Table	36
4.8. Programmable Logic.....	38
4.9. Math Function Block	40
4.10. CAN Transmit Setpoints	42
4.11. CAN Receive Setpoints	44
4.12. DTC React	44
4.13. General Diagnostics Options.....	45
4.14. Diagnostics Blocks.....	46
5. REFLASHING OVER CAN WITH EA BOOTLOADER	49
APPENDIX A - TECHNICAL SPECIFICATION	A-1

Table 1 – Output Type Options for Proportional Output.....	8
Table 2 – Digital Response Options.....	9
Table 3 – Delay Polarity	9
Table 4 – Enable Response Options.....	11
Table 5 – Override Response Options	11
Table 6 – Fault Response Options.....	12
Table 7 – Lamp Set by Event in DM1 Options	14
Table 8 – FMI for Event Options.....	15
Table 9 – Low Fault FMIs and corresponding High Fault FMIs	16
Table 10 – PID Response Options.....	16
Table 11 – X-Axis Type Options.....	17
Table 12 – PointN – Response Options	18
Table 13 – Table X – Condition Y, Operator Options.....	19
Table 14 – Table X – Conditions Logical Operator Options.....	19
Table 15 – Math function X Operator Options.....	20
Table 16 – Available Control Sources and Numbers	23
Table 17 – AX021210 Connector Pinout.....	25
Table 18 – J1939 Network Setpoints	30
Table 19 – Output Current Regulator Parameters Setpoints	31
Table 20 – Proportional Output Setpoints	33
Table 21 – Programmable Logic Setpoints	35
Table 22 – Lookup Table Setpoints.....	37
Table 23 – Programmable Logic Setpoints	39
Table 24 – Math Function Setpoints.....	41
Table 25 – CAN Transmit Message Setpoints	43
Table 26 – CAN Receive Setpoints.....	44
Table 27 – DTC React Setpoints.....	45
Table 28 – General Diagnostics Options Setpoints.....	46
Table 29 – Diagnostic Block Setpoints.....	48
Figure 1 - AX021210 Block Diagram.....	7
Figure 2 – Hotshot Digital Profile.....	10
Figure 3 – Double Minimum and Maximum Error Thresholds.....	13
Figure 4 - Analog source to Digital input	24
Figure 5 – AX021210 Dimensional Drawing	25
Figure 6 - Screen Capture of J1939 Setpoints.....	30
Figure 7- Screen Capture of Output Current Regulator Parameters Setpoints	30
Figure 8 - Screen Capture of Proportional Output Setpoints	32
Figure 9 - Screen Capture of Constant Data List Setpoints	34
Figure 10 - Screen Capture of PID Control Setpoints	34
Figure 11 - Screen Capture of Lookup table Setpoints	36
Figure 12 - Screen Capture of Programmable Logic Setpoints	38
Figure 13 - Screen Capture of Math Function Block Setpoints	40
Figure 14 - Screen Capture of CAN Transmit Message Setpoints	42
Figure 15 - Screen Capture of CAN Receive Message Setpoints	44
Figure 16 - Screen Capture of DTC React Setpoints.....	45
Figure 17 - Screen Capture of General Diagnostics Options Setpoints.....	45
Figure 18 - Screen Capture of Diagnostic Block Setpoints	46

REFERENCES

J1939	Recommended Practice for a Serial Control and Communications Vehicle Network, SAE, April 2011
J1939/21	Data Link Layer, SAE, December 2010
J1939/71	Vehicle Application Layer, SAE, March 2011
J1939/73	Application Layer-Diagnostics, SAE, February 2010
J1939/81	Network Management, SAE, May 2003
TDAX021210	Technical Datasheet, 10 Output Valve Controller with SAE J1939, Axiomatic Technologies 2020
UMAX07050x	User Manual, Electronic Assistant and USB-CAN, Axiomatic Technologies, July 2020

This document assumes the reader is familiar with the SAE J1939 standard. Terminology from the standard is used, but not described in this document.



NOTE: These products are supported by Electronic Assistant V5.13.88.0 and higher.

1. OVERVIEW OF CONTROLLER

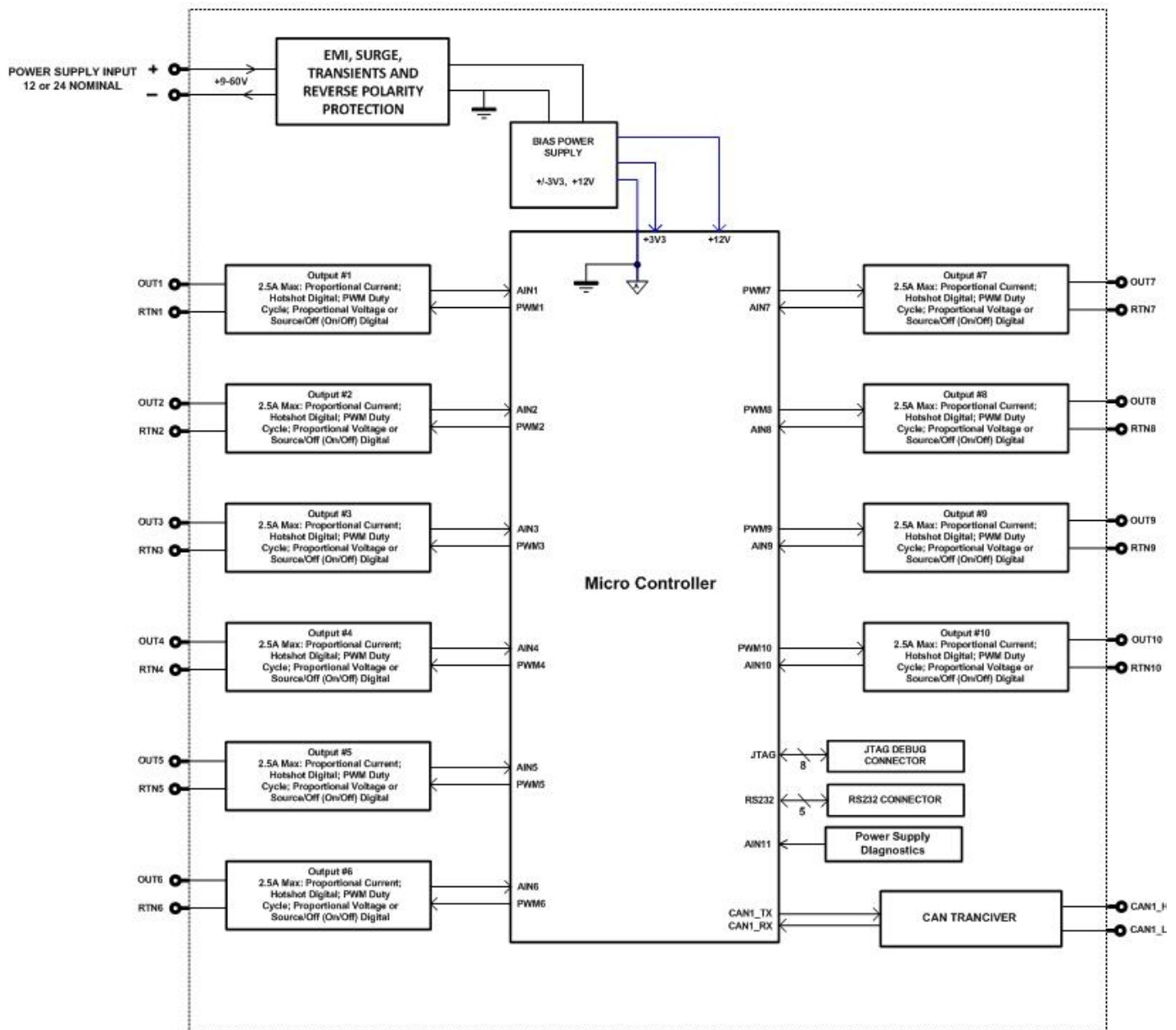

Figure 1 - AX021210 Block Diagram

The 10 Output Valve Controller (CAN-10OUT) is designed for extremely versatile control of up to ten proportional outputs to directly drive coils or other loads. Its flexible circuit design gives the user a wide range of configurable output types. The sophisticated control algorithms allow the user to program the controller for a wide range of applications without the need for custom software.

The ten outputs can be configured to drive proportional current (up to 2.5A each), hotshot digital current, proportional voltage (up to power supply), proportional PWM or straight on/off digital loads. The CAN-10OUT can be operated as either a self-contained control system, driving the outputs directly from the on-board logical function blocks, and/or it can be integrated into a SAE J1939 CAN Network. All outputs and logical function blocks on the unit are inherently independent from one another, but can be programmed to interact in a large number of ways.

A Windows-based Axiomatic Electronic Assistant[®] (EA) is used to configure the controller via an USB-CAN (AX070501) device. Configurable properties, EA setpoints, are outlined in chapter 4. Setpoint configuration can be saved in a file which can be used to easily program the same configuration into another 10 Output Valve Controller. Throughout this document, EA setpoint names are referred with bolded text in double-quotes and the setpoint option is referred with italicized text in single-quotes. For example, “**OutputType**” setpoint set to option ‘*Proportional Current (0-2.5A)*’.

In this document the configurable properties of the ECU are divided into function blocks, namely Output Function Block, Diagnostic Function Block, PID Control Function Block, Lookup Table Function Block, Programmable Logic Function Block, Math Function Block, DTC React Function Block, CAN Transmit Message Function Block and CAN Receive Message Function Block. These function blocks are presented in detail in next subchapters.

The 10 Output Valve Controller can be ordered using the following part numbers depending on the application.

AX021210	Controller with the default J1939 baud rate (250kbits/s).
AX021210-01	Controller with the 500kbits/s J1939 baud rate.
AX021210-02	Controller with a custom 1Mbits/s J1939 baud rate.

1.1. Output Function Blocks

The controller has ten Proportional outputs. The Proportional Outputs are half-bridge drives with high side sourcing up to 2,5A. Three different timer peripherals are used to produce half-bridge drive signals, thus Outputs are divided into three groups: Outputs 1 to 4, Outputs 5 to 8 and Outputs 9 to 10, according to assigned timer peripherals. All outputs within an output group operate on common frequency.

“**Output Type**” setpoint determines what kind of signal the output produces. Changing this setpoint causes other setpoints in the setpoint group to update to match selected type, thus the “**Output Type**” should be selected before configuring other setpoints within the setpoint group. “**Output Type**” setpoint options are listed in Table 1.

0	<i>Disabled</i>
1	<i>Proportional Current (0-2.5A)</i>
2	<i>Digital Hotshot (0-2.5A)</i>
3	<i>PWM Duty Cycle (0-100%)</i>
4	<i>Proportional Voltage (0-Vps)</i>
5	<i>Digital On/off (0-Vps)</i>

Table 1 – Output Type Options for Proportional Output

‘*Proportional Current*’ type has associated with it two setpoints not used by other types, which are the “**Dither Frequency**” and “**Dither Amplitude**” values. The output is controlled by high frequency signal (25 kHz), with the low frequency dither superimposed on top. Dither frequency is common for all outputs in an output group (Outputs 1 to 4, Outputs 5 to 8 and Outputs 9 to 10), thus changing it for one output will affect other outputs in the same output group. The dither frequency will match exactly what is programmed into the setpoint, but the exact amplitude of the dither will

depend on the properties of the load coil. When adjusting the dither amplitude value, select one that is high enough to ensure an immediate response to the coil to small changes in the control inputs, but not so large as to effect the accuracy or stability of the output. Refer to the coil's datasheet for more information.

The '*Proportional Voltage*' uses the measured value of the power supply, and adjusts the duty cycle of the output such that the average value will match the target output voltage. If the output is running at a high frequency (for example 25 kHz), the voltage can be easily averaged using a simple low pass filter.

The '*PWM Duty Cycle*' option allows the user to run the output at fixed frequency configure with "**PWM Output Frequency**" setpoint, while the duty cycle changes depending on the control signal. All Outputs in an output group operate on same output frequency, thus changing the frequency for one output changes frequency of the others in the same output group as well. "**PWM Output Frequency**" is editable only if none of the outputs in the output group is set to '*Proportional Current*' or '*Hotshot Digital*' type. Configuring output to '*Proportional Current*' or '*Hotshot Digital*' type changes frequency if the output group automatically to 25 kHz.

Instead of proportional output control, there are also two types of digital responses possible as well. With the '*Digital On/Off*' type, should the control require the output to be on; it will be turned on at whatever the system power supply is. The output will source whatever current is required by the load, up to 2,5A.

If a digital "**Output Type**" has been selected the "**Digital Response**" setpoint will be enabled as shown in Table 2.

0	<i>Normal On/Off</i>
1	<i>Inverse Logic</i>
2	<i>Latched Logic</i>
3	<i>Blinking Logic</i>

Table 2 – Digital Response Options

In a '*Normal*' response, when the Control input commands the output ON, then the output will be turned ON. However, in an '*Inverse*' response, the output will be ON unless the input commands the output ON, in which case it turns OFF.

The "**Digital Out Delay**" and "**Delay Polarity**" setpoints are associated with '*Normal*' "**Digital Response**". The "**Digital Out Delay**" defines output state change delay in milliseconds. Setting "**Digital Out Delay**" to 0ms applies no state change delay. The "**Delay Polarity**" setpoint defines which edge the state change delay will be applied. For example, selecting '*Rising Edge*' for "**Delay Polarity**" and setting "**Digital Out Delay**" value >0ms, applies defined delay when driving output signal state changes form OFF to ON.

0	<i>Rising Edge</i>
1	<i>Falling Edge</i>

Table 3 – Delay Polarity

If a '*Latched*' response is selected, when the input commands the state from OFF to ON, the output will change state.

If a 'Blinking' response is selected, then while the input command the output ON, it will blink at the rate in the "Digital Blink Rate" setpoint. When commanded OFF, the output will stay off. A blinking response is only available with a 'Digital On/Off' type of output (not a Hotshot type.)

The 'Hotshot Digital' type is different from in simple 'Digital On/Off' in that it still controls the current through the load. This type of output is used to turn on a coil then reduce the current so that the valve will remain open, as shown in Figure 2. Since less energy is used to keep the output engaged, this type of response is very useful to improve overall system efficiency. With this output type there are associated three setpoints: "Hold Current", "Hotshot Current" and "Hotshot Time" which are used to configure form of the output signal as shown in Figure 2.

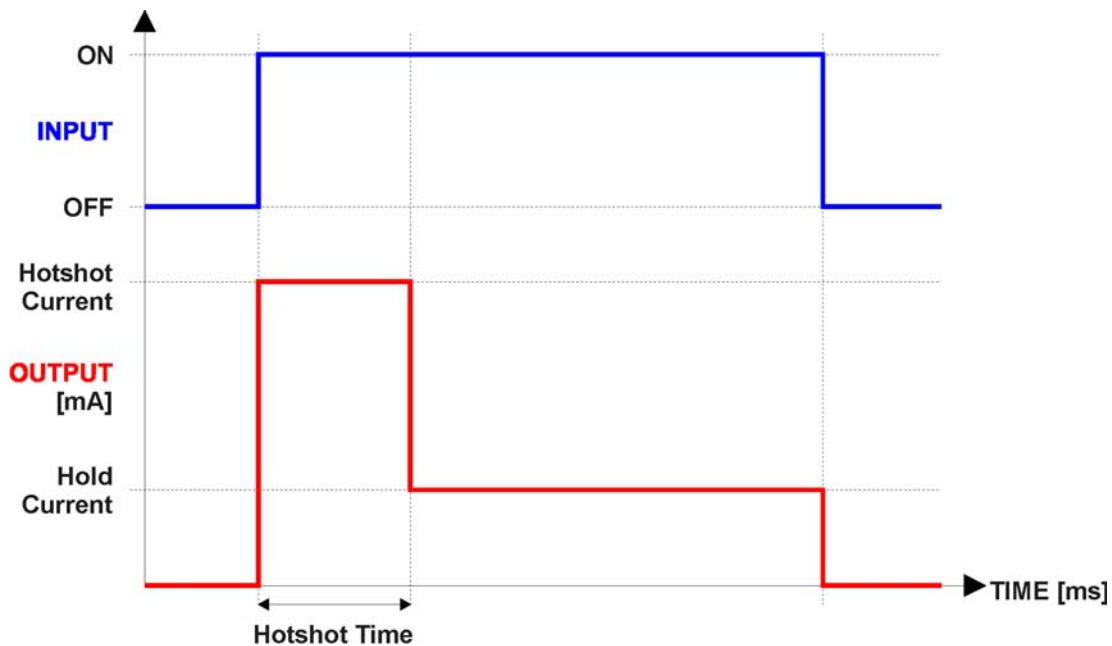

Figure 2 – Hotshot Digital Profile

For Proportional outputs signal minimum and maximum values are configured with "Output At Minimum Command" and "Output At Maximum Command" setpoints. Value range for both of the setpoints is limited by selected "Output Type".

Regardless of what type of control input is selected, the output will always respond in a linear fashion to changes in the input per Equation 1.

$$y = mx + a$$

$$m = \frac{Y_{max} - Y_{min}}{X_{max} - X_{min}}$$

$$a = Y_{min} - m * X_{min}$$

Equation 1 - Linear Slope Calculations

In the case of the Output Control Logic function block, X and Y are defined as

Xmin = Control Input Minimum Ymin = **“Output at Minimum Command”**

Xmax = Control Input Maximum Ymax = **“Output at Maximum Command”**

In all cases, while X-axis has the constraint that Xmin < Xmax, there is no such limitation on the Y-axis. Thus configuring **“Output At Minimum Command”** to be greater than **“Output At Maximum Command”** allows the output to follow the control signal inversely.

In order to prevent abrupt changes at the output due to sudden changes in the command input, the user can choose to use the independent up or down ramps to smooth out the coil’s response. The **“Ramp Up”** and **“Ramp Down”** setpoints are in milliseconds, and the step size of the output change will be determined by taking the absolute value of the output range and dividing it by the ramp time.

The **“Control Source”** setpoint together with **“Control Number”** setpoint determine which signal is used to drive the output. For example, setting **“Control Source”** to *‘Programmable Logic’* and **“Control Number”** to *‘1’*, connects output signal from Programmable Logic 1 to the output in question. Outputs respond in a linear fashion to changes in control signal. If a non-digital signal is selected to drive digital output the command state will be 0 (OFF) at or below the **“Output At Minimum Command”**, 1 (ON) at or above **“Output At Maximum Command”** and will not change in between those points.

In addition to the Control input, Proportional Outputs also support Enable and Override inputs.

The **“Enable Source”** setpoint together with **“Enable Number”** setpoint determine the enable signal for the output in question. The **“Enable Response”** setpoint is used to select how output will respond to the selected Enable signal. **“Enable Response”** setpoint options are listed in Table 4. If a non-digital signal is selected as Enable signal the signal is interpreted as shown in Figure 4.

0	<i>Enable When On, Else Shutoff</i>
1	<i>Enable When On, Else Rampoff</i>
2	<i>Enable When Off, Else Shutoff</i>
3	<i>Enable When Off, Else Rampoff</i>
4	<i>Enable When On, Else Ramp To Min</i>
5	<i>Enable When On, Else Ramp To Max</i>

Table 4 – Enable Response Options

Override input allows the output drive to be configured to go to a default value in the case of the override input being engaged/disengaged, depending on the logic selected in **“Override Response”**, presented on Table 5. When active, the output will be driven to the value in **“Output at Override Command”** regardless of the value of the Control input. The **“Override Source”** and **“Override Number”** together determine the Override input signal.

0	<i>Override When On</i>
1	<i>Override When Off</i>

Table 5 – Override Response Options

If a fault is detected in any of the active inputs (Control/Enable/Override) the output will respond per “**Control Fault Response**” setpoint as outlined in Table 6. Fault Value is defined by “**Output in Fault Mode**” setpoint value, which is interpreted in selected output units.

0	<i>Shutoff Output</i>
1	<i>Apply Fault Value</i>
2	<i>Hold Last Value</i>

Table 6 – Fault Response Options

Regardless of a selected output type, current through the load is available as Output Current Feedback signal and can be selected as input for a Diagnostic Block as described in section 1.2.

Another fault response that can be enabled is that a power supply over voltage or under voltage will automatically disable ALL outputs. Note: this setpoint is associated with the **Power Supply Diag** function block. Also, if the **Over Temperature Diag** function block is enabled, then a microprocessor over-temperature reading disables all the outputs until it has cooled back to the operating range.

The outputs are inherently protected against a short to GND or +Vps by circuitry. In case of a dead short, the hardware will automatically disable the output drive, regardless of what the processor is commanding for the output. When this happens, the processor detects output hardware shutdown and commands off the output in question. It will continue to drive non-shortened outputs normally and periodically (every 5 seconds) try to re-engage the short load, if still commanded to do so. If the fault has gone away since the last time the output was engaged while shorted, the controller will automatically resume normal operation.

In the case of an open circuit, there will be no interruption of the control for any of the outputs. The processor will continue to attempt to drive the open load.

The measured current through the load is available to be broadcasted on a CAN message if desired. It is also used as the input to the diagnostic function block for each output, and an open or shorted output can be broadcasted in a DM1 message on the CAN network

1.2. Diagnostic Function Blocks

The 10 Output Valve Controller supports diagnostic messaging. DM1 message is a message, containing Active Diagnostic Trouble Codes (DTC) that is sent to the J1939 network in case a fault has been detected. A Diagnostic Trouble Code is defined by the J1939 standard as a four byte value.

In addition to supporting the DM1 message, the following are supported:

SPN	Suspect Parameter Number	(user defined)
FMI	Failure Mode Identifier	(see Table 8 and Table 9)
CM	Conversion Method	(always set to 0)
OC	Occurrence Count	(number of times the fault has happened)
DM2	Previously Active Diagnostic Trouble Codes	Sent only on request

DM3	Diagnostic Data Clear/Reset of Previously Active DTCs	Done only on request
DM11	Diagnostic Data Clear/Reset for Active DTCs	Done only on request

Fault detection and reaction is a standalone functionality that can be configured to monitor and report diagnostics of various controller parameters. The 10 Output Valve Controller supports 13 Diagnostics Definitions, each freely configurable by the user.

By default, the monitoring of operating voltage, CPU temperature and receive message timeouts is configured to diagnostics blocks 1, 2 and 3. In case any of these three diagnostics blocks are needed for some other use, the default settings can be adjusted by the user to suit the application.

There are 4 fault types that can be used, “**Minimum and maximum error**”, “**Absolute value error**”, “**State error**” and “**Double minimum and maximum error**”.

Minimum and maximum error has two thresholds, “MIN Shutdown” and “MAX Shutdown” that have configurable, independent diagnostics parameters (SPN, FMI, Generate DTCs, delay before flagging status). In case the parameter to monitor stays between these two thresholds, the diagnostic is not flagged.

Absolute value error has one configurable threshold with configurable parameters. In case the parameter to monitor stays below this threshold, the diagnostic is not flagged.

State error is similar to the Absolute value error, the only difference is that State error does not allow the user to specify specific threshold values; thresholds ‘1’ and ‘0’ are used instead. This is ideal for monitoring state information, such as received message timeouts.

Double minimum and maximum error lets user to specify four thresholds, each with independent diagnostic parameters. The diagnostic status and threshold values is determined and expected as show in Figure 3 below.

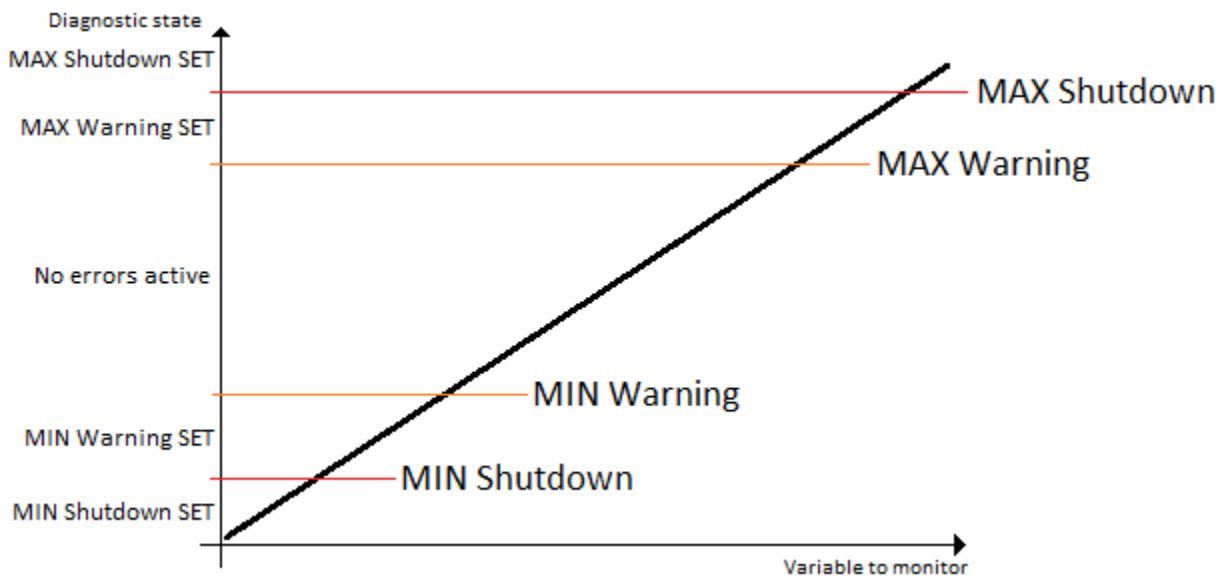

Figure 3 – Double Minimum and Maximum Error Thresholds

In case any of the Diagnostics blocks is configured to monitor Output Current Feedback, there is an internal error status flag maintained automatically for that particular output. This internal flag can be used for driving the particular output to a specified state in case of diagnostic event using Proportional Current Output setpoints “Control Fault Response”, “Output in Fault Mode” and “Fault Detection Enabled”.

There is also built in error status flags for power supply and CPU temperature monitoring. In case any of the diagnostics blocks is measuring these two parameters, the corresponding internal error status flags can be used for shutting down the unit in case of failure. The setpoints “**Power Fault Disables Outputs**” and “**Over Temperature Shutdown**” can be used for enabling the shutdown of the unit (shutdown == output driving is turned off).

While there are no active DTCs, the 10 Output Valve Controller will send “No Active Faults” message. If a previously inactive DTC becomes active, a DM1 will be sent immediately to reflect this. As soon as the last active DTC goes inactive, a DM1 indicating that there are no more active DTCs will be sent.

If there is more than one active DTC at any given time, the regular DM1 message will be sent using a multipacket message to the Requester Address using the Transport Protocol (TP).



At power up, the DM1 message will not be broadcasted until after 5 second delay. This is done to prevent any power up or initialization conditions from being flagged as an active error on the network.

When the fault is linked to a DTC, a non-volatile log of the occurrence count (OC) is kept. As soon as the controller detects a new (previously inactive) fault, it will start decrementing the “**Delay before Event is flagged**” timer for that Diagnostic function block. If the fault has remained present during the delay time, then the controller will set the DTC to active, and will increment the OC in the log. A DM1 will immediately be generated that includes the new DTC. The timer is provided so that intermittent faults do not overwhelm the network as the fault comes and goes, since a DM1 message would be sent every time the fault shows up or goes away.

By default, the fault flag is cleared when error condition that has caused it goes away. The DTC is made Previously Active and is it is no longer included in the DM1 message. To identify a fault having happened, even if the condition that has caused is one away, the “**Event Cleared only by DM11**” setpoint can be set to ‘True’. This configuration enables DTC to stay Active, even after the fault flag has been cleared, and be included in DM1 message until a Diagnostic Data Clear/Reset for Active DTCs (DM11) has been requested.

As defined by J1939 Standard the first byte of the DM1 message reflects the Lamp status. “**Lamp Set by Event**” setpoint determines the lamp type set in this byte of DTC. “**Lamp Set by Event**” setpoint options are listed in Table 7. By default, the ‘Amber, Warning’ lamp is typically the one set be any active fault.

0	<i>Protect</i>
1	<i>Amber Warning</i>
2	<i>Red Stop</i>
3	<i>Malfunction</i>

Table 7 – Lamp Set by Event in DM1 Options

“**SPN for Event**” defines suspect parameter number used as part of DTC. The default value zero is not allowed by the standard, thus no DM will be sent unless “**SPN for Event**” in is configured to be different from zero. **It is user’s responsibility to select SPN that will not violate J1939 standard.** When the “**SPN for Event**” is changed, the OC of the associated error log is automatically reset to zero.

0	<i>Data Valid But Above Normal Operational Range - Most Severe Level</i>
1	<i>Data Valid But Below Normal Operational Range - Most Severe Level</i>
2	<i>Data Intermittent</i>
3	<i>Voltage Above Normal, Or Shorted To High Source</i>
4	<i>Voltage Below Normal, Or Shorted To Low Source</i>
5	<i>Current Below Normal Or Open Circuit</i>
6	<i>Current Above Normal Or Grounded Circuit</i>
7	<i>Mechanical Error</i>
8	<i>Abnormal Frequency Or Pulse Width Or Period</i>
9	<i>Abnormal Update Rate</i>
10	<i>Abnormal Rate Of Change</i>
11	<i>Root Cause Not Known</i>
12	<i>Bad Component</i>
13	<i>Out Of Calibration</i>
14	<i>Special Instructions</i>
15	<i>Data Valid But Above Normal Operating Range – Least Severe Level</i>
16	<i>Data Valid But Above Normal Operating Range – Moderately Severe Level</i>
17	<i>Data Valid But Below Normal Operating Range – Least Severe Level</i>
18	<i>Data Valid But Below Normal Operating Range – Moderately Severe Level</i>
19	<i>Network Error</i>
20	<i>Data Drifted High</i>
21	<i>Data Drifted Low</i>
31	<i>Condition Exists</i>

Table 8 – FMI for Event Options

Every fault has associated a default FMI with them. The used FMI can be configured with “**FMI for Event**” setpoint, presented in Table 8. When an FMI is selected from Low Fault FMIs in Table 9 for a fault that can be flagged either high or low occurrence, it is recommended that the user would select the high occurrence FMI from the right column of Table 9. There is no automatic setting of High and Low FMIs in the firmware, the user can configure these freely.

Low Fault FMIs	High Fault FMIs
<i>FMI=1, Data Valid But Below Normal Operation Range – Most Severe Level</i>	<i>FMI=0, Data Valid But Above Normal Operational Range – Most Severe Level</i>
<i>FMI=4, Voltage Below Normal, Or Shorted to Low Source</i>	<i>FMI=3, Voltage Above Normal, Or Shorted To High Source</i>
<i>FMI=5, Current Below Normal Or Open Circuit</i>	<i>FMI=6, Current Above Normal Or Grounded Circuit</i>
<i>FMI=17, Data Valid But Below Normal Operating Range – Least Severe Level</i>	<i>FMI=15, Data Valid But Above Normal Operating Range – Least Severe Level</i>

<i>FMI=18, Data Valid But Below Normal Operating Level – Moderately Severe Level</i>	<i>FMI=16, Data Valid But Above Normal Operating Range – Moderately Severe Level</i>
<i>FMI=21, Data Drifted Low</i>	<i>FMI=20, Data Drifted High</i>

Table 9 – Low Fault FMIs and corresponding High Fault FMIs

1.3. PID Control Function Block

The PID Control function block is an independent logic block, but it is normally intended to be associated with proportional output control blocks described earlier. When the “**Control Source**” for an output has been setup as a ‘*PID Function Block*’, the command from the selected PID block drives the physical output on the 10 Output Valve Controller.

The “**PID Target Command Source**” and “**PID Target Command Number**” setpoints determine control input and the “**PID Feedback Input Source**” and “**PID Feedback Input Number**” setpoints determine the established the feedback signal to the PID function block. The “**PID Response Profile**” will use the selected inputs as per the options listed in Table 10. When active, the PID algorithm will be called every “**PID Loop Update Rate**” in milliseconds.

0	<i>Single Output</i>
1	<i>Setpoint Control</i>
2	<i>On When Over Target</i>
3	<i>On When Below Target</i>

Table 10 – PID Response Options

When a ‘*Single Output*’ response is selected, the Target and Feedback inputs do not have to share the same units. In both cases, the signals are converted to a percentage values based on the minimum and maximum values associated with the source function block.

For example, output of a Math Function Block could be used to set the target value, in which case it would be converted to a percentage value using “**Math Output Minimum Range**” and “**Math Output Maximum Range**” setpoints. The closed-loop feedback signal could be connected a ‘*CAN Receive Message*’ and selected as the feedback source. In this case the value of the message data would be converted to a percentage based on the “**Minimum Range**” and “**Maximum Range**” setpoints in the CAN Receive block. The output of the PID function would depend on the difference between the commanded target and the measured feedback as a percentage of each signals range. In this mode, the output of the block would be a value from -100% to 100%.

When a ‘*Setpoint Control*’ response is selected, the “**PID Target Command Source**” automatically gets updated to ‘*Control Constant Data*’ and cannot be changed. The value set in the associated constant in the Constant Data List function block becomes the desired target value. In this case, both the target and the feedback values are assumed to be in same units and range. The minimum and maximum values for the feedback automatically become the constraints on the constant target. In this mode, the output of the block would be a value from 0% to 100%.

The last two response options, ‘*On When Over Target*’ and ‘*On When Under Target*’, are designed to allow the user to combine the two proportional outputs as a push-pull drive for a system. Both outputs must be setup to use the same control input (linear response) and feedback signal in order to get the expected output response. In this mode, the output will be between 0% and 100%.

In Order to allow the output to stabilize, the user can select a non-zero value for “**PID Delta Tolerance**”. If the absolute value of $Error_k$ is less than this value, $Error_k$ in the formula below will be set to zero.

The PID algorithm used is shown below, where G , K_i , T_i , K_d , T_d and $Loop_Update_Rate$ are configurable parameters.

$$PIDOutput_k = P_k + I_k + D_k$$

$$P_k = P_Gain * Error_k$$

$$I_k = I_Gain * ErrorSum_k$$

$$D_k = D_Gain * (Error_k - Error_{k-1})$$

$$Error_k = Target - Feedback$$

$$ErrorSum_k = ErrorSum_{k-1} + Error_k$$

$$P_Gain = G$$

$$I_Gain = G * K_i * T / T_i \text{ (Note: If } T_i \text{ is zero, } I_Gain = 0)$$

$$D_Gain = G * K_d * T_d / T$$

$$T = Loop_Update_Rate * 0.001$$

Equation 2 - PID Control Algorithm

Each system will have to be turned for the optimum output response. Response times, overshoots and other variables will have to be decided by the customer using an appropriate PID tuning strategy. Axiomatic is not responsible for tuning the control system.

1.4. Lookup Table Function Block

Lookup Tables are used to give output response up to 10 slopes per input. If more than 10 slopes are required, A Programmable Logic Block can be used to combine up to three tables to get 30 slopes as described in Section 1.5.

Lookup tables have two differing modes defined by “**X-Axis Type**” setpoint, given in Table 11. Option ‘0 – Data Response’ is the normal mode where block input signal is selected with the “**X-Axis Source**” and “**X-Axis Number**” setpoints and X values present directly input signal values. With option ‘1 – Time Response’ the input signal is time and X values present time in milliseconds. And selected input signal is used as digital enable.

0	Data Response
1	Time Response

Table 11 – X-Axis Type Options

The slopes are defined with (x, y) points and associated point response. X value presents input signal value and Y value corresponding Lookup Table output value. “PointN – Response” setpoint defines type of the slope from preceding point to the point in question. Response options are given in Table 12. ‘Ramp To’ gives a linearized slope between points, whereas ‘Jump to’ gives a point to point response, where any input value between X_{N-1} and X_N will result Lookup Table output being Y_N . “Point0 – Response” is always ‘Jump To’ and cannot be edited. Choosing ‘Ignored’ response causes associated point and all the following points to be ignored.

0	<i>Ignore</i>
1	<i>Ramp To</i>
2	<i>Jump To</i>

Table 12 – PointN – Response Options

The X values are limited by minimum and maximum range of the selected input source if the source is a Math Function Block. For the fore mentioned sources X-Axis data will be redefined when ranges are changed, therefore inputs should be adjusted before changing X-Axis values. For other sources Xmin and Xmax are -100000 and 1000000. The X-Axis is constraint to be in rising order, thus value of the next index is greater than or equal to preceding one. Therefore, when adjusting the X-Axis data, it is recommended that X_{10} is changed first, then lower indexes in descending order.

$$Xmin \leq X_0 \leq X_1 \leq X_2 \leq X_3 \leq X_4 \leq X_5 \leq X_6 \leq X_7 \leq X_8 \leq X_9 \leq X_{10} \leq Xmax$$

The Y-Axis has no constraints on the data it presents, thus inverse, decreasing, increasing or other response can be easily established. The Smallest of the Y-Axis values is used as Lookup Table output min and the largest of the Y-Axis values is used as Lookup Table output max (i.e. used as Xmin and Xmax values in linear calculation, Section 1.1). Ignored points are not considered for min and max values.

1.5. Programmable Logic Function Block

The Programmable Logic Function Block is very powerful tool. A Programmable Logic can be linked to up to three Lookup Tables, any of which would be selected only under given conditions. Thus, output of a Programmable Logic at any given time will be the output of the Lookup Table selected by defined logic. Therefore, up to three different responses to the same input, or three different responses to different inputs, can become the input to another function block.

In order to enable any one of the Programmable Logic blocks, the “**Programmable Logic Enabled**” setpoint must be set to ‘True’. By default, all Logic blocks are disabled.

The three associated tables are selected by setting “**Table X – Lookup Table Block Number**” setpoint to desired Lookup Table number, for example selecting 1 would set Lookup Table 1 as TableX.

For each TableX there are three conditions that define the logic to select the associated Lookup Table as Logic output. Each condition implements function *Argument1 Operator Argument2* where Operator is logical operator defined by setpoint “**Table X – Condition Y, Operator**”. Setpoint options are listed in Table 13. Condition arguments are selected with “**Table x – Condition Y, Argument Z Source**” and “**Table x – Condition Y, Argument Z Number**” setpoints.

If '0 – Control not Used' option is selected as “**Table x – Condition Y, Argument Z Source**” the argument is interpreted as 0.

0	=, Equal
1	!=, Not Equal
2	>, Greater Than
3	>=, Greater Than or Equal
4	<, Less Than
5	<=, Less Than or Equal

Table 13 – Table X – Condition Y, Operator Options

The three conditions are evaluated and if the result satisfies logical operation defined with “**Table X – Conditions Logical Operator**” setpoint, given in Table 14, the associated Lookup Table is selected as output of the Logical block. Option '0 – Default Table' selects associated Lookup Table in all conditions.

0	Default Table (Table1)
1	Cnd1 And Cnd2 And Cnd3
2	Cnd1 Or Cnd2 Or Cnd3
3	(Cnd1 And Cnd2) Or Cnd3
4	(Cnd1 Or Cnd2) And Cnd3

Table 14 – Table X – Conditions Logical Operator Options

The three logical operations are evaluated in order and the first to satisfy gets selected, thus if Table1 logical operation is satisfied, the Lookup Table associated with Table1 gets selected regardless of two other logical operations. In addition, if none of the logical operations is satisfied the Lookup Table associated with Table1 gets selected.

1.6. Math Function Block

There are four mathematical function blocks that allow the user to define basic algorithms. A math function block can take up to five input signals. Each input is then scaled according to the associated limit and scaling setpoints.

Inputs are converted into percentage value based on the “**Function X Input Y Minimum**” and “**Function X Input Y Maximum**” values selected. For additional control the user can also adjust the “**Function X Input Y Scaler**”. By default, each input has a scaling 'weight' of 1.0 However, each input can be scaled from -1.0 to 1.0 as necessary before it is applied in the function.

A mathematical function block includes four selectable functions, in which each implements equation $A \text{ operator } B$, where A and B are function inputs and operator is function selected with a setpoint “**Math function X Operator**”. Setpoint options are presented in Table 15. The functions are connected together, so that result of the preceding function goes into Input A of the next function. Thus Function 1 has both Input A and Input B selectable with setpoints, where Functions 2 to 4 have only Input B selectable. Input is selected by setting “**Function X Input Y Source**” and “**Function X Input Y Number**”. If “**Function X Input B Source**” is set to 0 'Control not used' signal goes through function unchanged.

$$\text{Math Block Output} = \left(\left((A1 \text{ op1 } B1) \text{ op2 } B2 \right) \text{ op3 } B3 \right) \text{ op4 } B4$$

0	=, True when InA equals InB
1	!=, True when InA not equal InB
2	>, True when InA greater than InB
3	>=, True when InA greater than or equal InB
4	<, True when InA less than InB
5	<=, True when InA less than or equal InB
6	OR, True when InA or InB is True
7	AND, True when InA and InB are True
8	XOR, True when either InA or InB is True, but not both
9	+, Result = InA plus InB
10	-, Result = InA minus InB
11	x, Result = InA times InB
12	/, Result = InA divided by InB
13	MIN, Result = Smallest of InA and InB
14	MAX, Result = Largest of InA and InB

Table 15 – Math function X Operator Options

For logic operations (6, 7, and 8) scaled input greater than or equal to 1 is treated as TRUE. For logic operations (0 to 8), the result of the function will always be 0 (FALSE) or 1 (TRUE). For the arithmetic functions (9 to 14), it is recommended to scale the data such that the resulting operation will not exceed full scale (0 to 100%) and saturate the output result.

When dividing, a zero divider will always result in a 100% output value for the associated function.

Lastly the resulting mathematical calculation, presented as a percentage value, can be scaled into the appropriate physical units using the “**Math Output Minimum Range**” and “**Math Output Maximum Range**” setpoints. These values are also used as the limits when the Math Function is selected as the input source for another function block.

1.7. DTC React

The DTC React function block is a very simple function which will allow a received DTC, sent from another ECU on a DM1 message, to disable an output or be used as input to another type of logic block. Up to five SPN/FMI combinations can be selected.

Should a DM1 message be received with the SPN/FMI combination defined, the corresponding DTC State will be set to ON. Once ON, if the same SPN/FMI combination has not been received again after 3 seconds, the DTC State will be reset to OFF.

The DTC could be used as a digital input for any function block as appropriate.

1.8. CAN Transmit Message Function Block

The CAN Transmit function block is used to send any output from another function block (i.e. input, CAN receive) to the J1939 network. The AX021210 ECU has six CAN Transmit Messages and each message has four completely user defined signals.

1.8.1. CAN Transmit Message Setpoints

Each CAN Transmit Message setpoint group includes setpoints that effect the whole message and are thus mutual for all signals of the message. These setpoints are presented in this section. The setpoints that configure an individual signal are presented in next section.

The “**Transmit PGN**” setpoint sets PGN used with the message. **User should be familiar with the SAE J1939 standard, and select values for PGN/SPN combinations as appropriate from section J1939/71.**

“**Repetition Rate**” setpoint defines the interval used to send the message to the J1939 network. If the “**Repetition Rate**” is set to zero, the message is disabled unless it shares its PGN with another message. In case of a shared PGN repetition rate of the LOWEST numbered message are used to send the message ‘bundle’.



At power up, transmitted message will not be broadcasted until after a 5 second delay. This is done to prevent any power up or initialization conditions from creating problems on the network.

By default, all messages are sent on Proprietary B PGNs as broadcast messages. Thus “**Transmit Message Priority**” is always initialized to 6 (low priority) and the “**Destination Address**” setpoint is not used. This setpoint is only valid when a PDU1 PGN has been selected, and it can be set either to the Global Address (0xFF) for broadcasts, or sent to a specific address as setup by the user.

1.8.2. CAN Transmit Signal Setpoints

Each CAN transmit message has four associated signals, which define data inside the Transmit message. “**Control Source**” setpoint together with “**Control Number**” setpoint define the signal source of the message. “**Control Source**” and “**Control Number**” options are listed in Table 16. Setting “**Control Source**” to ‘*Control Not Used*’ disables the signal.

“**Transmit Data Size**” setpoint determines how many bits signal reserves from the message. “**Transmit Data Index in Array**” determines in which of 8 bytes of the CAN message LSB of the signal is located. Similarly, “**Transmit Bit Index in Byte**” determines in which of 8 bits of a byte the LSB is located. These setpoints are freely configurable, thus **it is the User’s responsibility to ensure that signals do not overlap and mask each other.**

“**Transmit Data Resolution**” setpoint determines the scaling done on the signal data before it is sent to the bus. “**Transmit Data Offset**” setpoint determines the value that is subtracted from the signal data before it is scaled. Offset and Resolution are interpreted in units of the selected source signal.

1.9. CAN Receive Function Block

The CAN Receive function block is designed to take any SPN from the J1939 network, and use it as an input to another function block (i.e. Outputs).

The “**Receive Message Enabled**” is the most important setpoint associated with this function block and it should be selected first. Changing it will result in other setpoints being enabled/disabled as appropriate. By default, ALL receive messages are disabled.

Once a message has been enabled, a Lost Communication fault will be flagged if that message is not received off the bus within the “**Receive Message Timeout**” period. This could trigger a Lost Communication event as described in section 1.2. In order to avoid timeouts on a heavily saturated network, it is recommended to set the period at least three times longer than the expected update rate. To disable the timeout feature, simply set this value to zero, in which case the received message will never trigger a Lost Communication fault.

By default, all control messages are expected to be sent to the 10 Output Valve Controller on Proprietary B PGNs. However, should a PDU1 message be selected, the 10 Output Valve Controller can be setup to receive it from any ECU by setting the “**Specific Address that sends the PGN**” to the Global Address (0xFF). If a specific address is selected instead, then any other ECU data on the PGN will be ignored.

The “**Receive Data Size**”, “**Receive Data Index in Array (LSB)**”, “**Receive Bit Index in Byte (LSB)**”, “**Receive Resolution**” and “**Receive Offset**” can all be used to map any SPN supported by the J1939 standard to the output data of the Received function block.

As mentioned earlier, a CAN receive function clock can be selected as the source of the control input for the output function blocks. When this is case, the “**Received Data Min (Off Threshold)**” and “**Received Data Max (On Threshold)**” setpoints determine the minimum and maximum values of the control signal. As the names imply, they are also used as the On/Off thresholds for digital output types. These values are in whatever units the data is AFTER the resolution and offset is applied to CAN receive signal.

The “**Send Acknowledge Message**” setpoint is used to enable acknowledgement message feature. When the value of this setpoint is TRUE, the controller sends an acknowledgement message each time the CAN Receive message in question is received.

The 10 Output Valve Controller I/O supports up to ten unique CAN Receive Messages. Defaults setpoint values are listed in section 4.10.

1.10. Available Control Sources

Many of the Function Blocks have selectable input signals, which are determined with “[Name] Source” and “[Name] Number” setpoints. Together, these setpoints uniquely select how the I/O of the various function blocks are linked together. “[Name] Source” setpoint determines the type of the source and “[Name] Number” selects the actual source if there is more than one of the same type. Available “[Name] Source” options and associated “[Name] Number” ranges are listed in Table 16. Sources from 0 to 9 are available for all blocks and sources from 10 to 13 are available sources for CAN Transmit messages. Thought input Sources are freely selectable, not all options would make sense for any particular input, and it is up to the user to program the controller in a logical and functional manner.

Sources	Number Range	Notes
---------	--------------	-------

<i>0: Control Not Used</i>	N/A	When this is selected, it disables all other setpoints associated with the signal in question.
<i>1: Received CAN Message</i>	1 to 5	User must enable the function block, as it is disabled by default.
<i>2: Digital Input Measured</i>	1 to 2	
<i>3: PID Function Block</i>	1 to 4	User must enable the function block, as it is disabled by default.
<i>4: Lookup Table</i>	1 to 8	
<i>5: Programmable Logic Block</i>	1 to 4	User must enable the function block, as it is disabled by default.
<i>6: Math Function Block</i>	1 to 4	User must enable the function block, as it is disabled by default.
<i>7: Control Constant Data</i>	1 to 15	1 = FALSE, 2 = TRUE, 3 to 15 = User Selectable
<i>8: Diagnostic Trouble Code</i>	1 to 5	Will only be valid if the corresponding DTC has a non-zero SPN
<i>9: Output Target Value</i>	1 to 10	Can be mapped to a CAN Transmit Message.
<i>10: Output Current Feedback</i>	1 to 10	Measured Feedback current from the proportional output in mA and used in Output Diagnostics, can be mapped to a CAN Transmit Message.
<i>11: Power Supply Measured</i>	N/A	Measured power supply value in Volts and used in Power Supply Diagnostics, can be mapped to a CAN Transmit Message.
<i>12: Processor Temperature Measured</i>	N/A	Measured processor temperature in °C and used in Over Temperature Diagnostics, can be mapped to a CAN Transmit Message.

Table 16 – Available Control Sources and Numbers

If a non-digital signal is selected to drive a digital input, the signal is interpreted to be OFF at or below the minimum of selected source and ON at or above the maximum of the selected source, and it will not change in between those points. Thus, analog to digital interpretation has a built in hysteresis defined by minimum and maximum of the selected source, as shown in Figure 4. For example, CAN Receive message signal is interpreted to be ON at or above “Maximum Range” and OFF at or below “Minimum Range”.

Control Constant Data has no unit nor minimum and maximum assigned to it, thus user has to assign appropriate constant values according to intended use.

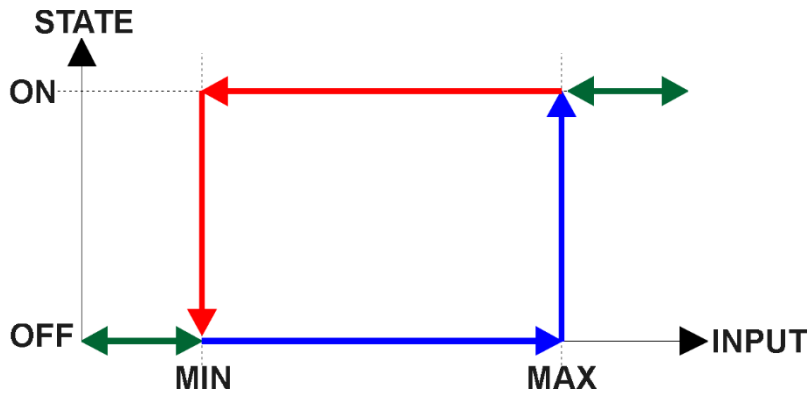

Figure 4 - Analog source to Digital input

2. INSTALLATION INSTRUCTIONS

2.1. Dimensions and Pinout

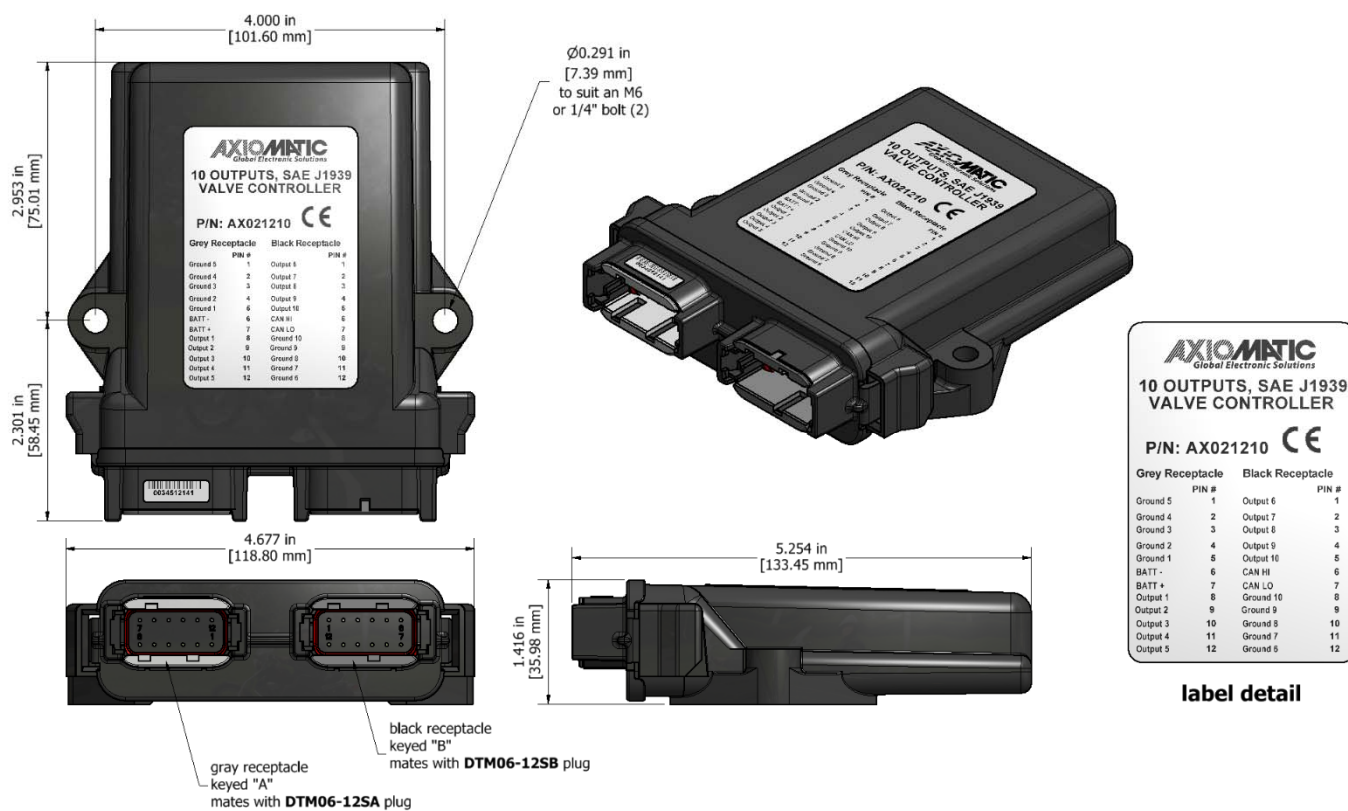

Figure 5 – AX021210 Dimensional Drawing

Grey Connector		Black Connector	
Pin #	Function	Pin #	Function
1	Ground 5	1	Output 6
2	Ground 4	2	Output 7
3	Ground 3	3	Output 8
4	Ground 2	4	Output 9
5	Ground 1	5	Output 10
6	BATT -	6	CAN HI
7	BATT +	7	CAN LO
8	Output 1	8	Ground 10
9	Output 2	9	Ground 9
10	Output 3	10	Ground 8
11	Output 4	11	Ground 7
12	Output 5	12	Ground 6

Table 17 – AX021210 Connector Pinout

3. OVERVIEW OF J1939 FEATURES

The software was designed to provide flexibility to the user with respect to messages sent from the ECU by providing:

- Configurable ECU Instance in the NAME (to allow multiple ECUs on the same network)
- Configurable Input Parameters
- Configurable PGN and Data Parameters
- Configurable Diagnostic Messaging Parameters, as required
- Diagnostic Log, maintained in non-volatile memory

3.1. Introduction to Supported Messages

The ECU is compliant with the standard SAE J1939, and supports following PGNs from the standard.

From J1939-21 – Data Link Layer

- | | | |
|--|------------|----------|
| • Request | 59904 | 0x00EA00 |
| • Acknowledgement | 59392 | 0x00E800 |
| • Transport Protocol – Connection Management | 60416 | 0x00EC00 |
| • Transport Protocol – Data Transfer Message | 60160 | 0x00EB00 |
| • Proprietary B | from 65280 | 0x00FF00 |
| | to 65535 | 0x00FFFF |

From J1939-73 – Diagnostics

- | | | |
|--|-------|----------|
| • DM1 – Active Diagnostic Trouble Codes | 65226 | 0x00FECA |
| • DM2 – Previously Active Diagnostic Trouble Codes | 65227 | 0x00FECB |
| • DM3 – Diagnostic Data Clear/Reset for Previously Active DTCs | 65228 | 0x00FECC |
| • DM11 – Diagnostic Data Clear/Reset for Active DTCs | 65235 | 0x00FED3 |
| • DM14 – Memory Access Request | 55552 | 0x00D900 |
| • DM15 – Memory Access Response | 55296 | 0x00D800 |
| • DM16 – Binary Data Transfer | 55040 | 0x00D700 |

From J1939-81 – Network Management

- | | | |
|--------------------------------|-------|----------|
| • Address Claimed/Cannot Claim | 60928 | 0x00EE00 |
| • Commanded Address | 65240 | 0x00FED8 |

From J1939-71 – Vehicle Application Layer

- | | | |
|---------------------------|-------|----------|
| • Software Identification | 65242 | 0x00FEDA |
|---------------------------|-------|----------|

None of the application layer PGNs are supported as part of the default configurations, but they can be selected as desired for transmit function blocks.

Setpoints are accessed using standard Memory Access Protocol (MAP) with proprietary addresses. The Electronic Assistant[®] EA (EA) allows for quick and easy configuration of the unit over CAN network.

3.2. NAME, Address and Software ID

The 10 Output Valve Controller I/O ECU has the following default for the J1939 NAME. The user should refer to the SAE J1939/81 standard for more information on these parameters and their ranges.

Arbitrary Address Capable	Yes
Industry Group	0, Global
Vehicle System Instance	0
Vehicle System	0, Non-specific system
Function	125, Axiomatic I/O Controller
Function Instance	3, Axiomatic AX021210
ECU Instance	0, First Instance
Manufacture Code	162, Axiomatic Technologies
Identity Number	Variable, uniquely assigned during factory programming for each ECU

The ECU Instance is a configurable setpoint associated with the NAME. Changing this value will allow multiple ECUs of this type to be distinguishable from one another when they are connected on the same network.

The default value of the “ECU Address” setpoint is 128 (0x80), which is the preferred starting address for self-configurable ECUs as set by the SAE in J1939 tables B3 and B7. The EA will allow the selection of any address between 0 and 253. ***It is user’s responsibility to select an address that complies with the standard.*** The user must also be aware that since the unit is arbitrary address capable, if another ECU with a higher priority NAME contends for the selected address, the 10 Output Valve Controller I/O will continue select the next highest address until it finds one that it can claim. See J1939/81 for more details about address claiming.

Software Identifier

PGN 65242		Software Identification	- SOFT
Transmission Repetition Rate:		On request	
Data Length:		Variable	
Extended Data Page:		0	
Data Page:		0	
PDU Format:		254	
PDU Specific:		218 PGN Supporting Information:	
Default Priority:		6	
Parameter Group Number:		65242 (0xFEDA)	
Start Position	Length	Parameter Name	SPN
1	1 Byte	Number of software identification fields	965
2-n	Variable	Software identification(s), Delimiter (ASCII “*”)	234

Byte 1 is set to 5, and the identification fields are as follows.

(Part Number)*(Version)*(Date)*(Owner)*(Description)

The EA shows all this information in “General ECU Information”, as shown below.

Note: The information provided in the Software ID is available for any J1939 service tool which supports the PGN -SOFT.

4. ECU SETPOINTS ACCESSED WITH ELECTRONIC ASSISTANT

This section describes in detail each setpoint, and their default and ranges. Default values presented in tables are values used when setpoint in question is active. Many of the setpoints are dependent on other setpoints and they may not be active by default. Associated Figures show screen capture of initial operation, however some of the setpoints are not in default condition as they are set differently to activate more setpoints for the image. The setpoints are divided into setpoint groups as they are shown in EA. For more information on how each setpoint is used by 10Output Valve controller, refer to the relevant section in this user manual.

4.1. Accessing the ECU Using EA

ECU with P/N AX021210 does not need any specific setup for EA. In order to access the high speed versions, AX021210-01 and/or AX021210-02, the CAN bus Baud Rate needs to be set accordingly. The CAN Interface Setup can be found from “Options” menu in EA.

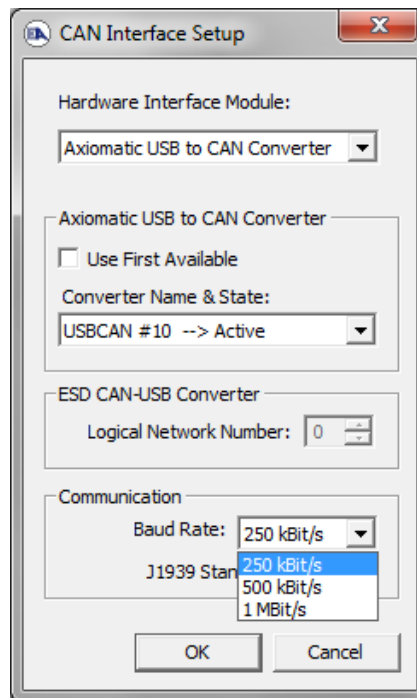

4.2. J1939 Network Parameters

“ECU Instance Number” and “ECU Address” setpoints and their effect are defined in Section 3.2.

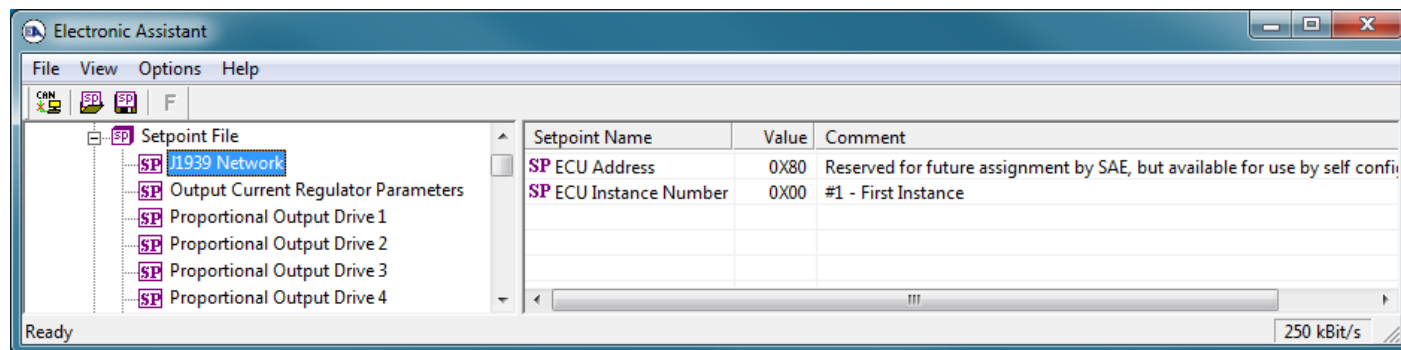

Figure 6 - Screen Capture of J1939 Setpoints

Name	Range	Default	Notes
ECU Address	0x80	0-253	Preferred address for a self-configurable ECU
ECU Instance	0-7	0x00	Per J1939-81

Table 18 – J1939 Network Setpoints

If non-default values for the “ECU Instance Number” or “ECU Address” are used, they will be mirrored during a setpoint file flashing, and will only take effect once the entire file has been downloaded to the unit. After the setpoint flashing is complete, the unit will claim the new address and/or re-claim the address with the new NAME. If these setpoints are changing, it is recommended to close and re-open the CAN connection on EA after the file is loaded so that only the new NAME and address are showing in the J1939 CAN Network ECU list.

4.3. Output Current Regulator Parameters

Each Output includes internal current regulator, which is utilized when output is in ‘Proportional Current’ or ‘Hotshot Digital’ mode. Output current response can be adjusted by changing current regulator P gain and/or I gain. To prevent unintentional adjustment these setpoints are passwords protected. The password is “Change10Out”.

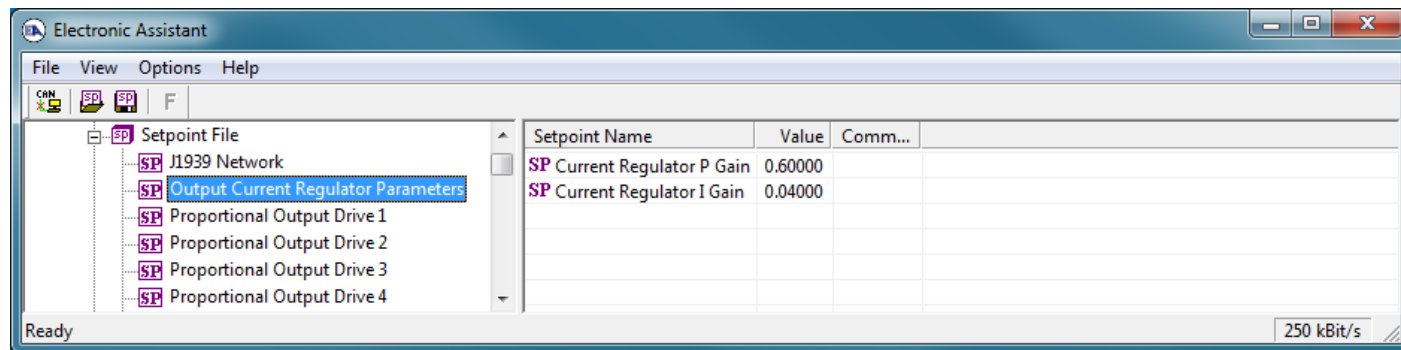

Figure 7- Screen Capture of Output Current Regulator Parameters Setpoints

Name	Range	Default	Notes
Current Regulator P Gain	0.000-100.000	0.60	
Current Regulator I Gain	0.000-100.000	0.04	

Table 19 – Output Current Regulator Parameters Setpoints

4.4. Proportional Output Setpoints

The Proportional Output Function Block is defined in Section 1.1. Please refer there for detailed information about how these setpoints are used. Outputs are disabled by default. In order to enable an output “**Output Type**” and “**Control Source**” have to be chosen.

Setpoint Name	Value	Comment
SP Output Type	1	Proportional Current
SP Output At Minimum Command	0	mA
SP Output At Maximum Command	2500	mA
SP Output At Override Command	750	mA
SP Dither Frequency	200	Hz
SP Dither Amplitude	0	mA
SP Ramp Up (Min to Max)	1000	ms
SP Ramp Down (Max to Mix)	1000	ms
SP PWM Output Frequency	25000	Hz, (Not configurable - Output in Current mode)
SP Hold Current		Parameter not used with current Output Type selected
SP Hotshot Current		Parameter not used with current Output Type selected
SP Hotshot Time		Parameter not used with current Output Type selected
SP Digital Response		Parameter not used with current Output Type selected
SP Digital Override State		Parameter not used with current Output Type selected
SP Digital Blink Rate		Parameter not used with current Output Type selected
SP Digital Out Delay		Parameter not used with current Output Type selected
SP Delay Polarity		Parameter not used with current Output Type selected
SP Control Source	1	Received CAN Message
SP Control Number	1	Received CAN Message #1
SP Enable Source	0	Control Not Used
SP Enable Number		Parameter not used with current Enable Source selected
SP Enable Response		Parameter not used with current Enable Source selected
SP Override Source	0	Control Not Used
SP Override Number		Parameter not used with current Override Source selected
SP Override Response		Parameter not used with current Override Source selected
SP Output Fault Response	0	Shutoff Output
SP Output in Fault Mode		Parameter not used with current Control Fault Response
SP Fault Detection is Enabled	1	True

Figure 8 - Screen Capture of Proportional Output Setpoints

Name	Range	Default	Notes
Output Type	Drop List	Disabled	See Table 1
Output At Minimum Command	0 to Limit	300mA	
Output At Maximum Command	0 to Limit	2500mA	
Output At Override Command	0 to Limit	750mA	
Dither Frequency	50 to 400Hz	200Hz	
Dither Amplitude	0 to 500 mA	0	
Ramp Up (Min to Max)	0 to 10 000ms	1000ms	
Ramp Down (Max to Min)	0 to 10 000ms	1000ms	
PWM Output Frequency	1Hz to 25 000Hz	500Hz	
Hold Current	0 to 1500mA	500mA	
Hotshot Current	0 to 1500mA	1000mA	
Hotshot Time	500 to 10 000 ms	1000ms	
Digital Response	Drop List	Normal On/Off	See Table 2
Digital Override State	Drop List	ON	ON / OFF
Digital Blink Rate	100 to 5000 ms	1000ms	
Digital Out Delay	0 to 60000ms	0ms	0ms → No delay
Delay Polarity	Drop List	Rising Edge	See Table 3
Control Source	Drop List	CAN Transmit Message	See Table 16
Control Number	Depends on control source	1	See Table 16
Enable Source	Drop List	Control not used	See Table 16
Enable Number	Depends on enable source	1	See Table 16
Enable Response	Drop List	Enable When On, else Shutoff	See Table 4
Override Source	Drop List	Control not used	See Table 16
Override Number	Depends on enable source	1	See Table 16
Override Response	Drop List	Override When On	See Table 5
Fault Detection is Enabled	Drop List	True	
Output Fault Response	Drop List	Shutoff Output	See Table 6
Output in Fault Mode	Depends on Output type	500mA	
Hysteresis to Clear Fault	0.01 to 250.00 mA	100.00mA	
Event Generates a DTC by DM1	Drop List	False	
Event Cleared only by DM11	Drop List	False	
Lamp Set by Event in DM1	Drop List	Amber Warning	See Table 7
SPN for Event used in DTC	0...65535	0	
FMI for Event used in DTC	Drop List	5, Open circuit	See Table 8
Delay Before Sending DM1	0...60000 ms	1000	

Table 20 – Proportional Output Setpoints

4.5. Constant Data List

The Constant Data List Function Block is provided to allow the user to select values as desired for various logic block functions.

The first two constants are fixed values of 0 (False) and 1 (True) for use in binary logic. The remaining 13 constants are fully user programmable to any value between +/- 1 000 000. The default values (shown in Figure 9) are arbitrary and should be configured by the user as appropriate for their application.

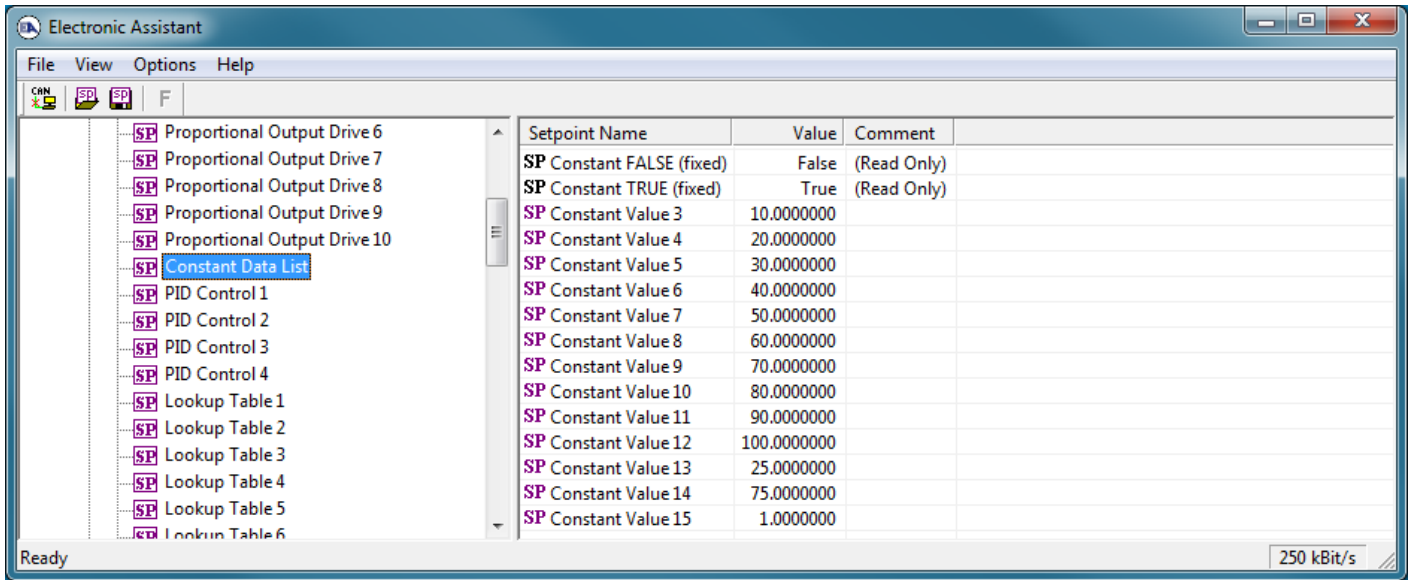

Figure 9 - Screen Capture of Constant Data List Setpoints

4.6. PID Control

The PID Control Function Block is defined in Section 1.3. Please refer there for detailed information about how all these setpoints are used.

Command Source is set to 'Control Not Used' by default. To enable a PID Control, select appropriate "PID Target Command Source" and "PID Feedback Input Source".

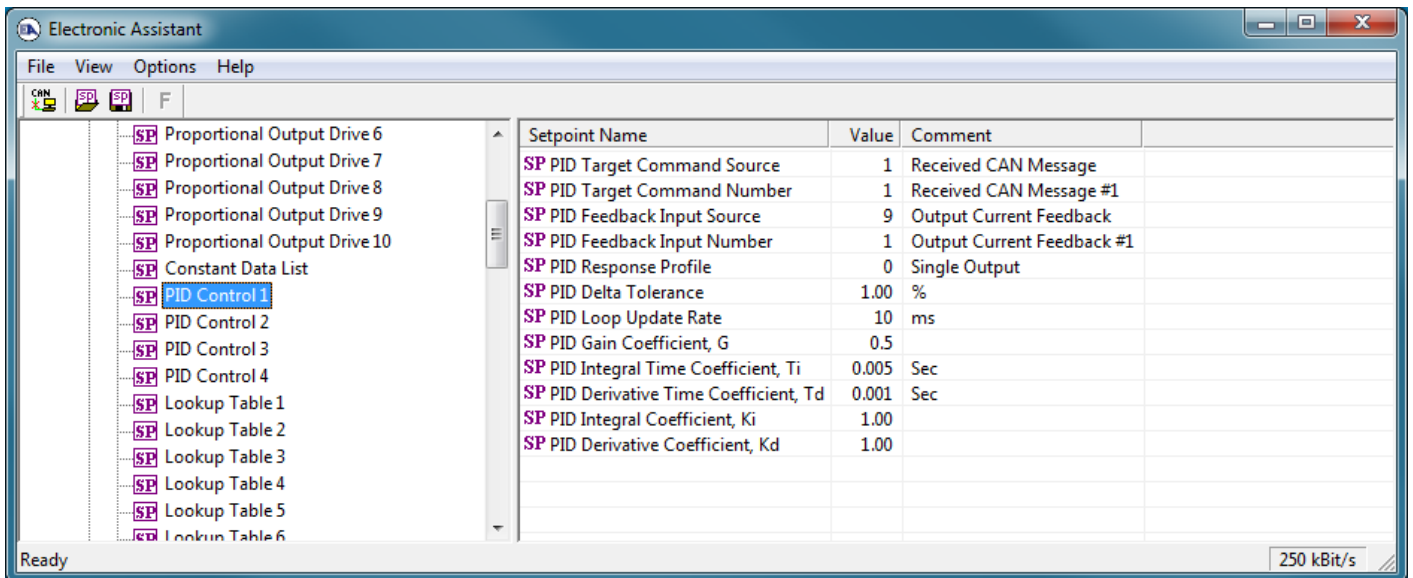

Figure 10 - Screen Capture of PID Control Setpoints

Name	Range	Default	Notes
PID Target Command Source	Drop List	Control Not Used	See Table 16

PID Target Command Number	Depends on control source	1	See Table 16
PID Feedback Input Source	Drop List	Control Not Used	See Table 16
PID Feedback Input Number	Depends on control source	1	See Table 16
PID Response Profile	Drop List	Single Output	See Table 10
PID Delta Tolerance	0 to 100	1.00 %	%
PID Loop Update Rate	1 to 60 000 ms	10ms	1 ms resolution
PID Gain Coefficient, G	0.1 to 10	0.5	See Equation 2
PID Integral Time Coefficient, Ti	0.001 to 10 Sec	0.005 Sec	0.001 Sec (1ms) resolution
PID Derivative Time Coefficient, Td	0.001 to 10 Sec	0.001 Sec	0.001 Sec (1ms) resolution
PID Integral Coefficient, Ki	0 to 10	1.00	0 disables integral, PD ctrl
PID Derivative Coefficient, Kd	0 to 10	1.00	0 disables derivative, PI ctrl

Table 21 – Programmable Logic Setpoints

4.7. Lookup Table

The Lookup Table Function Block is defined in Section 1.4 Please refer there for detailed information about how all these setpoints are used. “**X-Axis Source**” is set to ‘*Control Not Used*’ by default. To enable a Lookup Table select appropriate “**X-Axis Source**”.

Setpoint Name	Value	Comment
SP X-Axis Source	1	Received CAN Message
SP X-Axis Number	1	Received CAN Message #1
SP X-Axis Type	0	Data Response
SP Point 1 - Response	1	Ramp To
SP Point 2 - Response	1	Ramp To
SP Point 3 - Response	1	Ramp To
SP Point 4 - Response	1	Ramp To
SP Point 5 - Response	1	Ramp To
SP Point 6 - Response	1	Ramp To
SP Point 7 - Response	1	Ramp To
SP Point 8 - Response	1	Ramp To
SP Point 9 - Response	1	Ramp To
SP Point 10 - Response	1	Ramp To
SP Point 0 - X Value	0.000	
SP Point 1 - X Value	0.500	
SP Point 2 - X Value	1.000	
SP Point 3 - X Value	1.500	
SP Point 4 - X Value	2.000	
SP Point 5 - X Value	2.500	
SP Point 6 - X Value	3.000	
SP Point 7 - X Value	3.500	
SP Point 8 - X Value	4.000	
SP Point 9 - X Value	4.500	
SP Point 10 - X Value	5.000	
SP Point 0 - Y Value	0.000	
SP Point 1 - Y Value	10.000	
SP Point 2 - Y Value	20.000	
SP Point 3 - Y Value	30.000	
SP Point 4 - Y Value	40.000	
SP Point 5 - Y Value	50.000	
SP Point 6 - Y Value	60.000	
SP Point 7 - Y Value	70.000	
SP Point 8 - Y Value	80.000	
SP Point 9 - Y Value	90.000	
SP Point 10 - Y Value	100.000	

Figure 11 - Screen Capture of Lookup table Setpoints

Name	Range	Default	Notes
X-Axis Source	Drop List	Control Not Used	See Table 16
X-Axis Number	Depends on control source	1	See Table 16
X-Axis Type	Drop List	Data Response	See Table 11
Point 1 - Response	Drop List	Ramp To	See Table 12
Point 2 - Response	Drop List	Ramp To	See Table 12
Point 3 - Response	Drop List	Ramp To	See Table 12
Point 4 - Response	Drop List	Ramp To	See Table 12
Point 5 - Response	Drop List	Ramp To	See Table 12
Point 6 - Response	Drop List	Ramp To	See Table 12
Point 7 - Response	Drop List	Ramp To	See Table 12
Point 8 - Response	Drop List	Ramp To	See Table 12
Point 9 - Response	Drop List	Ramp To	See Table 12
Point 10 - Response	Drop List	Ramp To	See Table 12
Point 0 - X Value	From X-Axis source minimum to Point 1 - X Value	X-Axis source minimum 0.000	See Section 1.4
Point 1 - X Value	From Point 0 - X Value to Point 2 - X Value	0.500	See Section 1.4
Point 2 - X Value	From Point 1 - X Value to Point 3 - X Value	1.000	See Section 1.4
Point 3 - X Value	From Point 2 - X Value to Point 4 - X Value	1.500	See Section 1.4
Point 4 - X Value	From Point 3 - X Value to Point 5 - X Value source	2.000	See Section 1.4
Point 5 - X Value	From Point 4 - X Value to Point 6 - X Value	2.500	See Section 1.4
Point 6 - X Value	From Point 5 - X Value to Point 7 - X Value	3.000	See Section 1.4
Point 7 - X Value	From Point 6 - X Value to Point 8 - X Value	3.500	See Section 1.4
Point 8 - X Value	From Point 7 - X Value to Point 9 - X Value	4.000	See Section 1.4
Point 9 - X Value	From Point 8 - X Value to Point 10 - X Value	4.500	See Section 1.4
Point 10 - X Value	From Point 9 - X Value to X-Axis source maximum	X-Axis source maximum 5.000	See Section 1.4
Point 0 - Y Value	-10 ⁶ to 10 ⁶	0.000	
Point 1 - Y Value	-10 ⁶ to 10 ⁶	10.000	
Point 2 - Y Value	-10 ⁶ to 10 ⁶	20.000	
Point 3 - Y Value	-10 ⁶ to 10 ⁶	30.000	
Point 4 - Y Value	-10 ⁶ to 10 ⁶	40.000	
Point 5 - Y Value	-10 ⁶ to 10 ⁶	50.000	
Point 6 - Y Value	-10 ⁶ to 10 ⁶	60.000	
Point 7 - Y Value	-10 ⁶ to 10 ⁶	70.000	
Point 8 - Y Value	-10 ⁶ to 10 ⁶	80.000	
Point 9 - Y Value	-10 ⁶ to 10 ⁶	90.000	
Point 10 - Value	-10 ⁶ to 10 ⁶	100.000	

Table 22 – Lookup Table Setpoints

4.8. Programmable Logic

The Programmable Logic function block is defined in Section 1.5. Please refer there for detailed information about how all these setpoints are used. **“Programmable Logic Enabled”** is *‘False’* by default. To enable Logic set **“Programmable Logic Enabled”** to *‘True’* and select appropriate **“Argument Source”**.

Setpoint Name	Value	Comment
SP Programmable Logic Enabled	1	True
SP Table 1 - Lookup Table Block Number	1	Lookup Table 1
SP Table 1 - Conditions Logical Operator	0	Default Table
SP Table 1 - Condition 1, Argument 1 Source	1	Received CAN Message
SP Table 1 - Condition 1, Argument 1 Number	1	Received CAN Message #1
SP Table 1 - Condition 1, Operator	0	=, Equal
SP Table 1 - Condition 1, Argument 2 Source	1	Received CAN Message
SP Table 1 - Condition 2, Argument 2 Number	2	Received CAN Message #2
SP Table 1 - Condition 2, Argument 1 Source	0	Control Not Used
SP Table 1 - Condition 2, Argument 1 Number		Parameter not used with current Control Source selected
SP Table 1 - Condition 2, Operator		Parameter not used with current Control Source selected
SP Table 1 - Condition 2, Argument 2 Source	0	Control Not Used
SP Table 1 - Condition 2, Argument 2 Number		Parameter not used with current Control Source selected
SP Table 1 - Condition 3, Argument 1 Source	0	Control Not Used
SP Table 1 - Condition 3, Argument 1 Number		Parameter not used with current Control Source selected
SP Table 1 - Condition 3, Operator		Parameter not used with current Control Source selected
SP Table 1 - Condition 3, Argument 2 Source	0	Control Not Used
SP Table 1 - Condition 3, Argument 2 Number		Parameter not used with current Control Source selected
SP Table 2 - Lookup Table Block Number	2	Lookup Table 2
SP Table 2 - Conditions Logical Operator	0	Default Table
SP Table 2 - Condition 1, Argument 1 Source	0	Control Not Used
SP Table 2 - Condition 1, Argument 1 Number		Parameter not used with current Control Source selected
SP Table 2 - Condition 1, Operator		Parameter not used with current Control Source selected
SP Table 2 - Condition 1, Argument 2 Source	0	Control Not Used
SP Table 2 - Condition 1, Argument 2 Number		Parameter not used with current Control Source selected
SP Table 2 - Condition 2, Argument 1 Source	0	Control Not Used
SP Table 2 - Condition 2, Argument 1 Number		Parameter not used with current Control Source selected
SP Table 2 - Condition 2, Operator		Parameter not used with current Control Source selected
SP Table 2 - Condition 2, Argument 2 Source	0	Control Not Used
SP Table 2 - Condition 2, Argument 2 Number		Parameter not used with current Control Source selected
SP Table 2 - Condition 3, Argument 1 Source	0	Control Not Used
SP Table 2 - Condition 3, Argument 1 Number		Parameter not used with current Control Source selected
SP Table 2 - Condition 3, Operator		Parameter not used with current Control Source selected
SP Table 2 - Condition 3, Argument 2 Source	0	Control Not Used
SP Table 2 - Condition 3, Argument 2 Number		Parameter not used with current Control Source selected
SP Table 3 - Lookup Table Block Number	3	Lookup Table 3
SP Table 3 - Conditions Logical Operator	0	Default Table
SP Table 3 - Condition 1, Argument 1 Source	0	Control Not Used
SP Table 3 - Condition 1, Argument 1 Number		Parameter not used with current Control Source selected
SP Table 3 - Condition 1, Operator		Parameter not used with current Control Source selected
SP Table 3 - Condition 1, Argument 2 Source	0	Control Not Used
SP Table 3 - Condition 1, Argument 2 Number		Parameter not used with current Control Source selected
SP Table 3 - Condition 2, Argument 1 Source	0	Control Not Used
SP Table 3 - Condition 2, Argument 1 Number		Parameter not used with current Control Source selected
SP Table 3 - Condition 2, Operator		Parameter not used with current Control Source selected
SP Table 3 - Condition 2, Argument 2 Source	0	Control Not Used
SP Table 3 - Condition 2, Argument 2 Number		Parameter not used with current Control Source selected
SP Table 3 - Condition 3, Argument 1 Source	0	Control Not Used
SP Table 3 - Condition 3, Argument 1 Number		Parameter not used with current Control Source selected
SP Table 3 - Condition 3, Operator		Parameter not used with current Control Source selected
SP Table 3 - Condition 3, Argument 2 Source	0	Control Not Used

Figure 12 - Screen Capture of Programmable Logic Setpoints

Setpoint ranges and default values for Programmable Logic Blocs are listed in Table 23. Only “**Table1**” setpoint are listed, because other “**TableX**” setpoints are similar, except for the default value of the “**Lookup Table Block Number**” setpoint, which is X for “**TableX**”.

Name	Range	Default	Notes
Programmable Logic Enabled	Drop List	False	
Table1 - Lookup Table Block Number	1 to 8	Look up Table 1	
Table1 - Conditions Logical Operation	Drop List	Default Table	See Table 14
Table1 - Condition1, Argument 1 Source	Drop List	Control Not Used	See Table 16
Table1 - Condition1, Argument 1 Number	Depends on control source	1	See Table 16
Table1 - Condition1, Operator	Drop List	=, Equal	See Table 13
Table1 - Condition1, Argument 2 Source	Drop List	Control Not Used	See Table 16
Table1 - Condition1, Argument 2 Number	Depends on control source	1	See Table 16
Table1 - Condition2, Argument 1 Source	Drop List	Control Not Used	See Table 16
Table1 - Condition2, Argument 1 Number	Depends on control source	1	See Table 16
Table1 - Condition2, Operator	Drop List	=, Equal	See Table 13
Table1 - Condition2, Argument 2 Source	Drop List	Control Not Used	See Table 16
Table1 - Condition2, Argument 2 Number	Depends on control source	1	See Table 16
Table1 - Condition3, Argument 1 Source	Drop List	Control Not Used	See Table 16
Table1 - Condition3, Argument 1 Number	Depends on control source	1	See Table 16
Table1 - Condition3, Operator	Drop List	=, Equal	See Table 13
Table1 - Condition3, Argument 2 Source	Drop List	Control Not Used	See Table 16
Table1 - Condition3, Argument 2 Number	Depends on control source	1	See Table 16

Table 23 – Programmable Logic Setpoints

4.9. Math Function Block

The Math Function Block is defined in Section 1.6. Please refer there for detailed information about how all these setpoints are used. “**Math Function Enabled**” is ‘False’ by default. To enable a Math Function Block, set “**Math Function Enabled**” to ‘True’ and select appropriate “**Input Source**”.

Setpoint Name	Value	Comment
SP Math Function Enabled	1	True
SP Function 1 Input A Source	1	Received CAN Message
SP Function 1 Input A Number	1	Received CAN Message #1
SP Function 1 Input A Minimum	0.00	
SP Function 1 Input A Maximum	100.00	
SP Function 1 Input A Scaler	1.00	
SP Function 1 Input B Source	0	Control Not Used
SP Function 1 Input B Number		Parameter not used with current Control Source sel
SP Function 1 Input B Minimum		Parameter not used with current Control Source sel
SP Function 1 Input B Maximum		Parameter not used with current Control Source sel
SP Function 1 Input B Scaler		Parameter not used with current Control Source sel
SP Math Function 1 Operation		Parameter not used with current Control Source sel
SP Function 2 Input B Source	0	Control Not Used
SP Function 2 Input B Number		Parameter not used with current Control Source sel
SP Function 2 Input B Minimum		Parameter not used with current Control Source sel
SP Function 2 Input B Maximum		Parameter not used with current Control Source sel
SP Function 2 Input B Scaler		Parameter not used with current Control Source sel
SP Math Function 2 Operation (Input A = Result of Function 1)		Parameter not used with current Control Source sel
SP Function 3 Input B Source	0	Control Not Used
SP Function 3 Input B Number		Parameter not used with current Control Source sel
SP Function 3 Input B Minimum		Parameter not used with current Control Source sel
SP Function 3 Input B Maximum		Parameter not used with current Control Source sel
SP Function 3 Input B Scaler		Parameter not used with current Control Source sel
SP Math Function 3 Operation (Input A = Result of Function 2)		Parameter not used with current Control Source sel
SP Function 4 Input B Source	0	Control Not Used
SP Function 4 Input B Number		Parameter not used with current Control Source sel
SP Function 4 Input B Minimum		Parameter not used with current Control Source sel
SP Function 4 Input B Maximum		Parameter not used with current Control Source sel
SP Function 4 Input B Scaler		Parameter not used with current Control Source sel
SP Math Function 4 Operation (Input A = Result of Function 3)		Parameter not used with current Control Source sel
SP Math Output Minimum Range	0.00	
SP Math Output Maximum Range	100.00	

Figure 13 - Screen Capture of Math Function Block Setpoints

Name	Range	Default	Notes
Math Function Enabled	Drop List	False	
Function 1 Input A Source	Drop List	Control not used	See Table 16
Function 1 Input A Number	Depends on control source	1	See Table 16
Function 1 Input A Minimum	-10^6 to 10^6	0.0	
Function 1 Input A Maximum	-10^6 to 10^6	100.0	
Function 1 Input A Scaler	-1.00 to 1.00	1.00	
Function 1 Input B Source	Drop List	Control not used	See Table 16
Function 1 Input B Number	Depends on control source	1	See Table 16
Function 1 Input B Minimum	-10^6 to 10^6	0.0	
Function 1 Input B Maximum	-10^6 to 10^6	100.0	
Function 1 Input B Scaler	-1.00 to 1.00	1.00	
Math Function 1 Operation	Drop List	=, True when InA Equals InB	See Table 15
Function 2 Input B Source	Drop List	Control not used	See Table 16
Function 2 Input B Number	Depends on control source	1	See Table 16
Function 2 Input B Minimum	-10^6 to 10^6	0.0	
Function 2 Input B Maximum	-10^6 to 10^6	100.0	
Function 2 Input B Scaler	-1.00 to 1.00	1.00	
Math Function 3 Operation	Drop List	=, True when InA Equals InB	See Table 15
Function 3 Input B Source	Drop List	Control not used	See Table 16
Function 3 Input B Number	Depends on control source	1	See Table 16
Function 3 Input B Minimum	-10^6 to 10^6	0.0	
Function 3 Input B Maximum	-10^6 to 10^6	100.0	
Function 3 Input B Scaler	-1.00 to 1.00	1.00	
Math Function 3 Operation	Drop List	=, True when InA Equals InB	See Table 15
Function 4 Input B Source	Drop List	Control not used	See Table 16
Function 4 Input B Number	Depends on control source	1	See Table 16
Function 4 Input B Minimum	-10^6 to 10^6	0.0	
Function 4 Input B Maximum	-10^6 to 10^6	100.0	
Function 4 Input B Scaler	-1.00 to 1.00	1.00	
Math Function 4 Operation	Drop List	=, True when InA Equals InB	See Table 15
Math Output Minimum Range	-10^6 to 10^6	0.0	
Math Output Maximum Range	-10^6 to 10^6	100.0	

Table 24 – Math Function Setpoints

4.10. CAN Transmit Setpoints

CAN Transmit Message Function Block is presented in Section 1.8. Please refer there for detailed information how these setpoints are used. **“Transmit Repetition Rate”** is 0ms by default, thus no message will be sent.

Setpoint Name	Value	Comment
SP Transmit PGN	0xFF00	Transmit PGN: 65280
SP Transmit Repetition Rate	0	ms
SP Transmit Message Priority	6	
SP Destination Address (PDU1)	255	Destination ECU Address: 0xFF
SP Signal 1 Data Source	8	Output Target Value
SP Signal 1 Data Number	1	Output Target Value #1
SP Signal 1 Transmit Data Size	5	Continuous 2-Bytes
SP Signal 1 Transmit Data Index in Array (LSB)	2	3rd Byte Position
SP Signal 1 Transmit Bit Index in Byte (LSB)		Parameter not used with current Data Size selected
SP Signal 1 Transmit Data Resolution	0.0010000	
SP Signal 1 Transmit Data Offset	0.0000000	
SP Signal 2 Data Source	0	Control Not Used
SP Signal 2 Data Number		Parameter not used with current Data Source
SP Signal 2 Transmit Data Size		Parameter not used with current Data Source
SP Signal 2 Transmit Data Index in Array (LSB)		Parameter not used with current Data Source
SP Signal 2 Transmit Bit Index in Byte (LSB)		Parameter not used with current Data Source
SP Signal 2 Transmit Data Resolution		Parameter not used with current Data Source
SP Signal 2 Transmit Data Offset		Parameter not used with current Data Source
SP Signal 3 Data Source	0	Control Not Used
SP Signal 3 Data Number		Parameter not used with current Data Source
SP Signal 3 Transmit Data Size		Parameter not used with current Data Source
SP Signal 3 Transmit Data Index in Array (LSB)		Parameter not used with current Data Source
SP Signal 3 Transmit Bit Index in Byte (LSB)		Parameter not used with current Data Source
SP Signal 3 Transmit Data Resolution		Parameter not used with current Data Source
SP Signal 3 Transmit Data Offset		Parameter not used with current Data Source
SP Signal 4 Data Source	0	Control Not Used
SP Signal 4 Data Number		Parameter not used with current Data Source
SP Signal 4 Transmit Data Size		Parameter not used with current Data Source
SP Signal 4 Transmit Data Index in Array (LSB)		Parameter not used with current Data Source
SP Signal 4 Transmit Bit Index in Byte (LSB)		Parameter not used with current Data Source
SP Signal 4 Transmit Data Resolution		Parameter not used with current Data Source
SP Signal 4 Transmit Data Offset		Parameter not used with current Data Source

Figure 14 - Screen Capture of CAN Transmit Message Setpoints

Name	Range	Default	Notes
Transmit PGN	0xff00 ... 0xffff	Different for each	See Section 1.8.1
Transmit Repetition Rate	0 ... 65000 ms	0ms	0ms disables transmit
Transmit Message Priority	0...7	6	Proprietary B Priority
Destination Address	0...255	255	Not used by default
Signal 1 Control Source	Drop List	Different for each	See Table 16
Signal 1 Control Number	Drop List	Different for each	See 1.8.2
Signal 1 Transmit Data Size	Drop List	2 bytes	
Signal 1 Transmit Data Index in Array	0-7	2	
Signal 1 Transmit Bit Index In Byte	0-7	0	
Signal 1 Transmit Data Resolution	-100000.0 to 100000	0.001	
Signal 1 Transmit Data Offset	-10000 to 10000	0.0	
Signal 2 Control Source	Drop List	Signal undefined	See Table 16
Signal 2 Control Number	Drop List	Signal undefined	See 1.8.2
Signal 2 Transmit Data Size	Drop List	2 bytes	
Signal 2 Transmit Data Index in Array	0-7	0	
Signal 2 Transmit Bit Index In Byte	0-7	0	
Signal 2 Transmit Data Resolution	-100000.0 to 100000	0.001	
Signal 2 Transmit Data Offset	-10000 to 10000	0.0	
Signal 3 Control Source	Drop List	Signal undefined	See Table 16
Signal 3 Control Number	Drop List	Signal undefined	See 1.8.2
Signal 3 Transmit Data Size	Drop List	2 bytes	
Signal 3 Transmit Data Index in Array	0-7	0	
Signal 3 Transmit Bit Index In Byte	0-7	0	
Signal 3 Transmit Data Resolution	-100000.0 to 100000	0.001	
Signal 3 Transmit Data Offset	-10000 to 10000	0.0	
Signal 4 Control Source	Drop List	Signal undefined	See Table 16
Signal 4 Control Number	Drop List	Signal undefined	See 1.8.2
Signal 4 Transmit Data Size	Drop List	2 bytes	
Signal 4 Transmit Data Index in Array	0-7	0	
Signal 4 Transmit Bit Index In Byte	0-7	0	
Signal 4 Transmit Data Resolution	-100000.0 to 100000	0.001	
Signal 4 Transmit Data Offset	-10000 to 10000	0.0	

Table 25 – CAN Transmit Message Setpoints

4.11. CAN Receive Setpoints

The Math Function Block is defined in Section 1.9. Please refer there for detailed information about how these setpoints are used. **“Receive Message Timeout”** is set to 0ms by default. To enable Receive message set **“Receive Message Timeout”** that differs from zero.

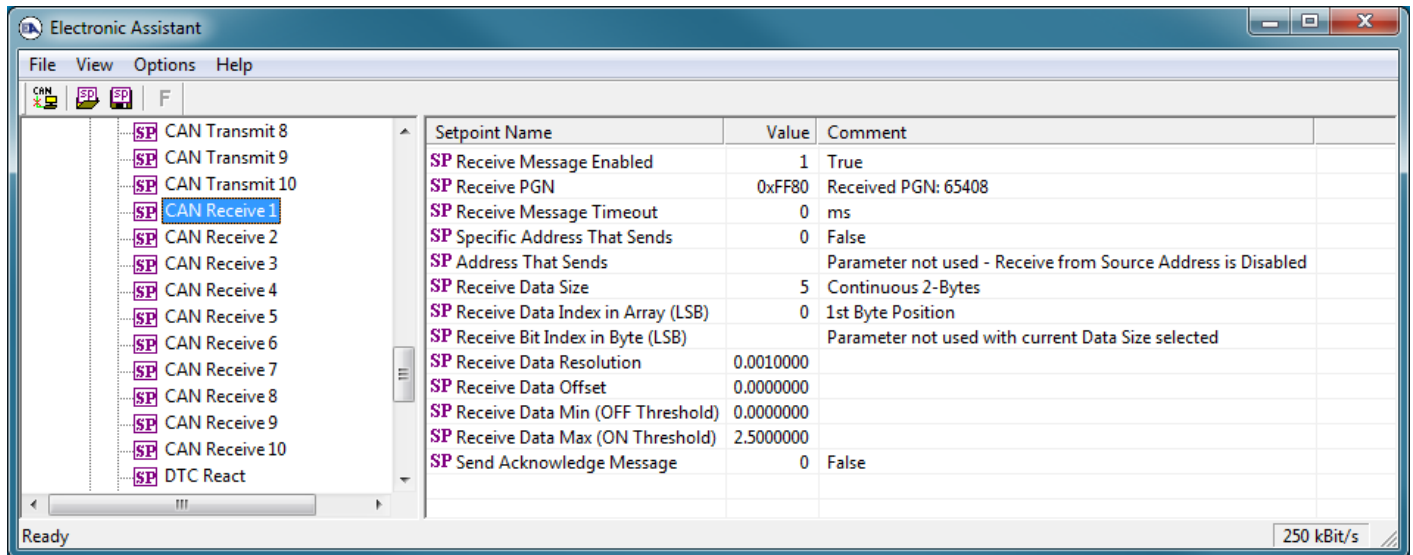

Figure 15 - Screen Capture of CAN Receive Message Setpoints

Name	Range	Default	Notes
Received Message Enabled	Drop List	False	
Received PGN	0 to 65536	Different for each	
Received Message Timeout	0 to 60 000 ms	0ms	
Specific Address that sends PGN	Drop List	False	
Address That Sends	0 to 255	254 (0xFE, Null Addr)	
Receive Transmit Data Size	Drop List	2 bytes	
Receive Transmit Data Index in Array	0-7	0	
Receive Transmit Bit Index In Byte	0-7	0	
Receive Transmit Data Resolution	-100000.0 to 100000	0.001	
Receive Transmit Data Offset	-10000 to 10000	0.0	
Receive Data Min (Off Threshold)	-1000000 to Max	0.0	
Receive Data Max (On Threshold)	-100000 to 100000	2.0	
Send Acknowledge Message	Drop List	False	

Table 26 – CAN Receive Setpoints

4.12. DTC React

The DTC React Function Block is defined in Section 1.7. Please refer there for detailed information about how these setpoints are used.

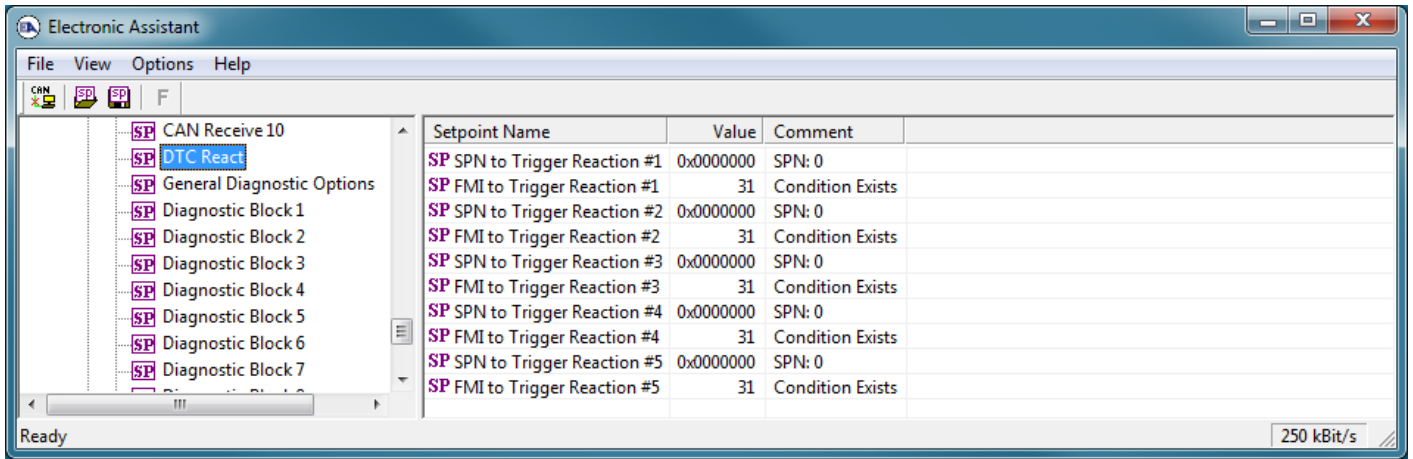

Figure 16 - Screen Capture of DTC React Setpoints

Name	Range	Default	Notes
SPN to Trigger Reaction #1	0 to 524287	0	0 is an illegal value, and disables the DTC
FMI to Trigger Reaction #X	Drop List	31, Condition Exists	Supports all FMIs in the J1939 standard

Table 27 – DTC React Setpoints

4.13. General Diagnostics Options

These setpoints control the shutdown of the ECU in case of a power supply or CPU temperature related errors. Refer to section 1.2 for more info.

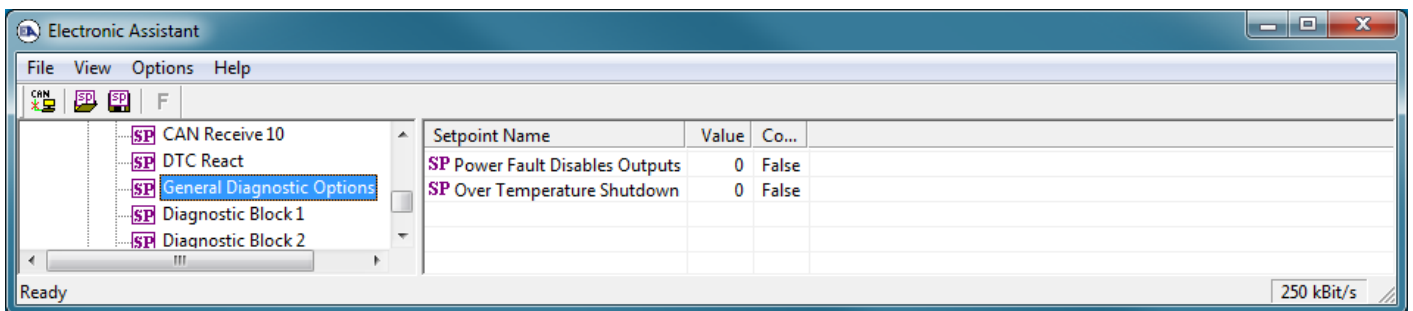

Figure 17 - Screen Capture of General Diagnostics Options Setpoints

Name	Range	Default	Notes
Power Fault Disables Outputs	Drop List	0	
Over Temperature Shutdown	Drop List	0	

Table 28 – General Diagnostics Options Setpoints

4.14. Diagnostics Blocks

There are 13 Diagnostics blocks that can be configured to monitor various parameters of the Controller. The Diagnostic Function Block is defined in section 1.2. Please refer there for detailed information how these setpoints are used.

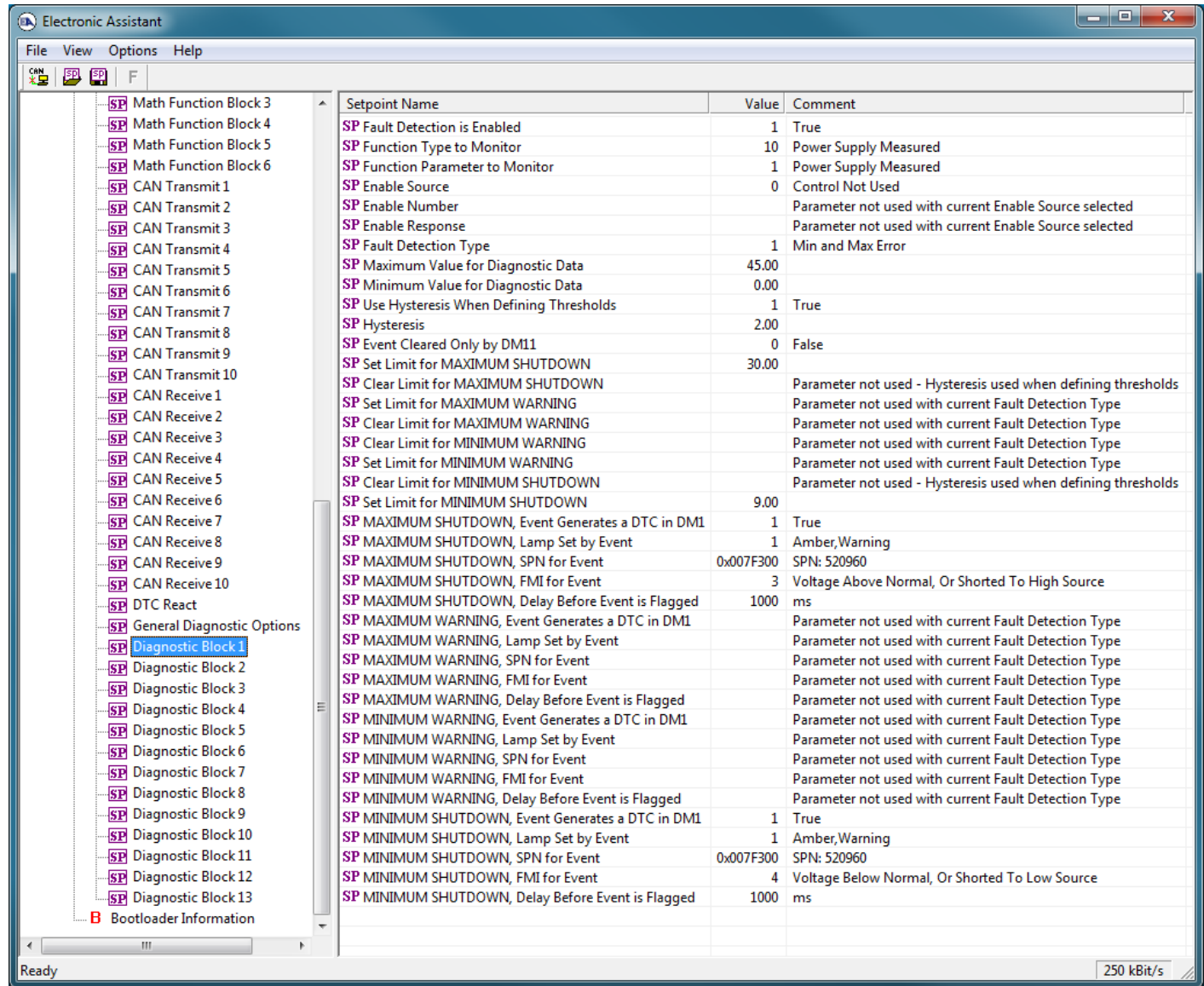

Figure 18 - Screen Capture of Diagnostic Block Setpoints

Name	Range	Default	Notes
Fault Detection is Enabled	Drop List	False	
Function Type to Monitor	Drop List	0 – Control not used	
Function parameter to Monitor	Drop List	0 – No selection	
Fault Detection Type	Drop List	1 – Min and Max Error	See section 1.2
Maximum Value for Diagnostic Data	Minimum Value for Diagnostic Data ... 4.28e ⁹	5.0	
Minimum Value for Diagnostic Data	0.0 ... Maximum Value for Diagnostic Data	0.0	
Use Hysteresis When Defining Thresholds	Drop List	False	
Hysteresis	0.0 ... Maximum Value for Diagnostic Data	0.0	
Event Cleared only by DM11	Drop List	False	
Set Limit for MAXIMUM SHUTDOWN	Minimum Value for Diagnostic Data ... Maximum Value for Diagnostics Data	4.8	
Clear Limit for MAXIMUM SHUTDOWN	Minimum Value for Diagnostic Data ... Maximum Value for Diagnostics Data	4.6	
Set Limit for MAXIMUM WARNING	Minimum Value for Diagnostic Data ... Maximum Value for Diagnostics Data	0.0	
Clear Limit for MAXIMUM WARNING	Minimum Value for Diagnostic Data ... Maximum Value for Diagnostics Data	0.0	
Clear Limit for MINIMUM WARNING	Minimum Value for Diagnostic Data ... Maximum Value for Diagnostics Data	0.0	
Set Limit for MINIMUM WARNING	Minimum Value for Diagnostic Data ... Maximum Value for Diagnostics Data	0.0	
Clear Limit for MINIMUM SHUTDOWN	Minimum Value for Diagnostic Data ... Maximum Value for Diagnostics Data	0.4	
Set Limit for MINIMUM SHUTDOWN	Minimum Value for Diagnostic Data ... Maximum Value for Diagnostics Data	0.2	
MAXIMUM SHUTDOWN, Event Generates a DTC in DM1	Drop List	True	
MAXIMUM SHUTDOWN, Lamp Set by Event	Drop List	0 – Protect	See Table 7
MAXIMUM SHUTDOWN, SPN for Event	0...524287	520448 (\$7F100)	It is the user's responsibility to select an SPN that will not violate the J1939 standard.

MAXIMUM SHUTDOWN, FMI for Event	Drop List	3, Voltage Above Normal	See Table 8
MAXIMUM SHUTDOWN, Delay Before Event is Flagged	0...60000 ms	1000	
MAXIMUM WARNING, Event Generates a DTC in DM1	Drop List	True	
MAXIMUM WARNING, Lamp Set by Event	Drop List	0 – Protect	See Table 7
MAXIMUM WARNING, SPN for Event	0...524287	520704 (\$7F200)	It is the user's responsibility to select an SPN that will not violate the J1939 standard.
MAXIMUM WARNING, FMI for Event	Drop List	3, Voltage Above Normal	See Table 8
MAXIMUM WARNING, Delay Before Event is Flagged	0...60000 ms	1000	
MINIMUM WARNING, Event Generates a DTC in DM1	Drop List	True	
MINIMUM WARNING, Lamp Set by Event	Drop List	0 – Protect	See Table 7
MAXIMUM WARNING, SPN for Event	0...524287	520960 (\$7F300)	It is the user's responsibility to select an SPN that will not violate the J1939 standard.
MINIMUM WARNING, FMI for Event	Drop List	4, Voltage Below Normal	See Table 8
MINIMUM WARNING, Delay Before Event is Flagged	0...60000 ms	1000	
MINIMUM SHUTDOWN, Event Generates a DTC in DM1	Drop List	True	
MINIMUM SHUTDOWN, Lamp Set by Event	Drop List	Amber Warning	See Table 7
MINIMUM SHUTDOWN, SPN for Event	0...524287	521216 (\$7F400)	It is the user's responsibility to select an SPN that will not violate the J1939 standard.
MINIMUM SHUTDOWN, FMI for Event	Drop List	4, Voltage Below Normal	See Table 8
MINIMUM SHUTDOWN, Delay Before Event is Flagged	0...60000 ms	1000	

Table 29 – Diagnostic Block Setpoints

5. REFLASHING OVER CAN WITH EA BOOTLOADER

The AX021210 can be upgraded with new application firmware using the **Bootloader Information** section. This section details the simple step-by-step instructions to upload new firmware provided by Axiomatic onto the unit via CAN, without requiring it to be disconnected from the J1939 network.

Note: To upgrade the firmware use Electronic Assistant®  V5.13.88.0 or higher.

1. When EA first connects to the ECU, the **Bootloader Information** section will display the following information.

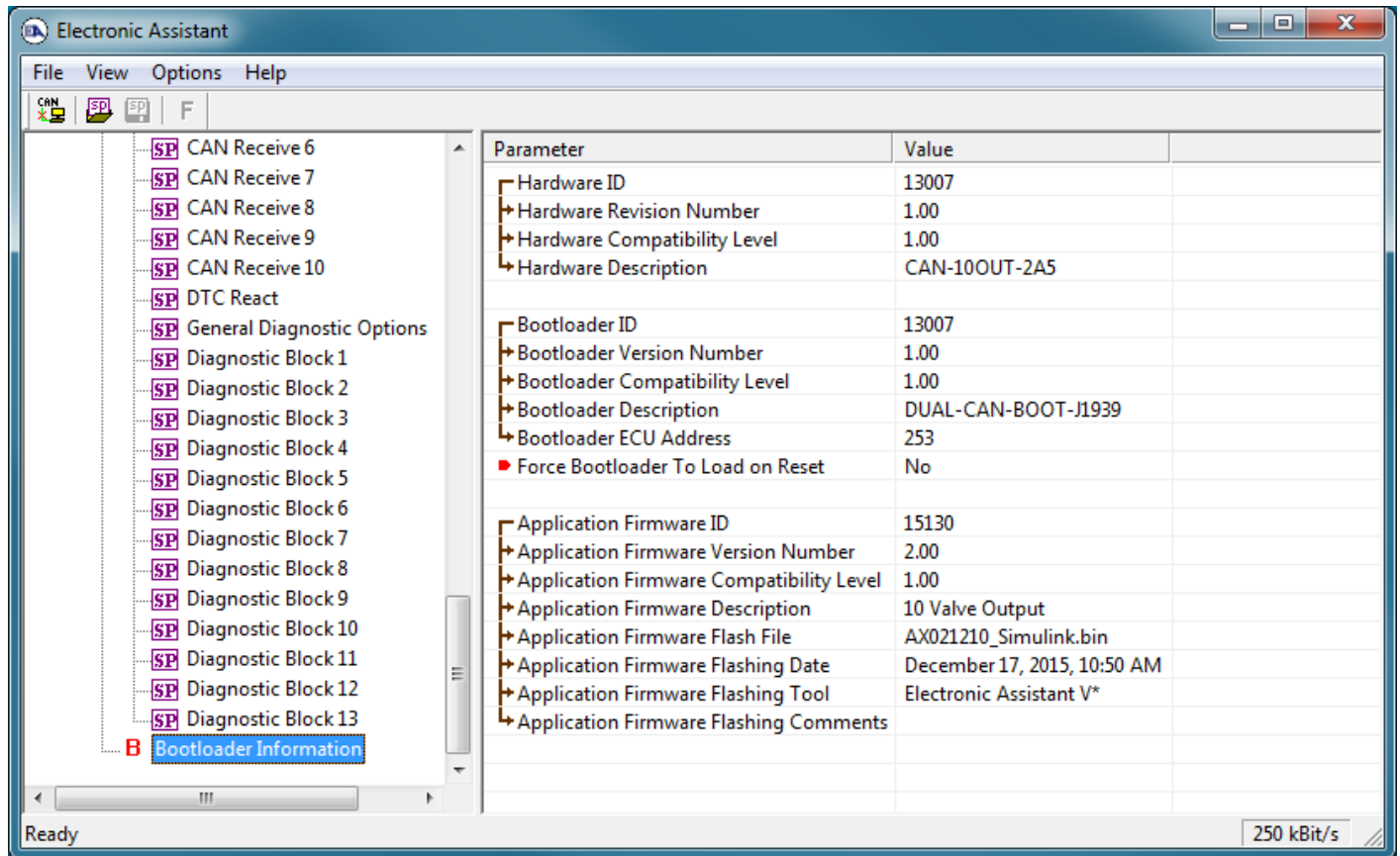

2. To use the bootloader for upgrading the firmware running on the ECU, change the variable “**Force Bootloader To Load on Reset**” to Yes.

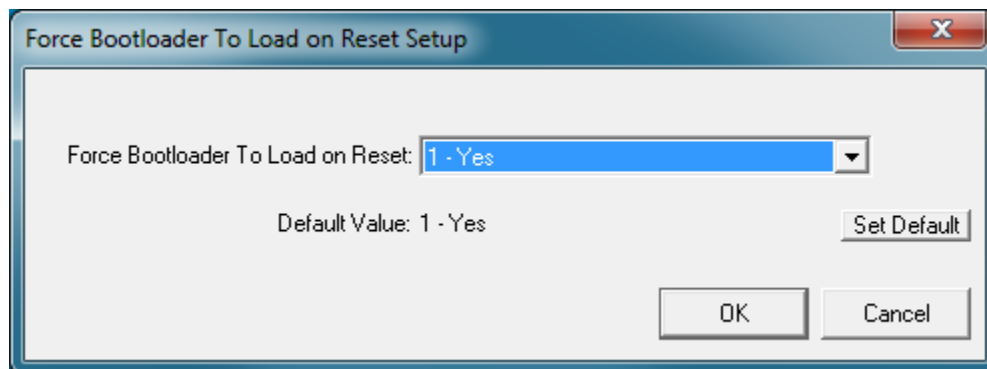

3. When the prompt box asks if you want to reset the ECU, select Yes.

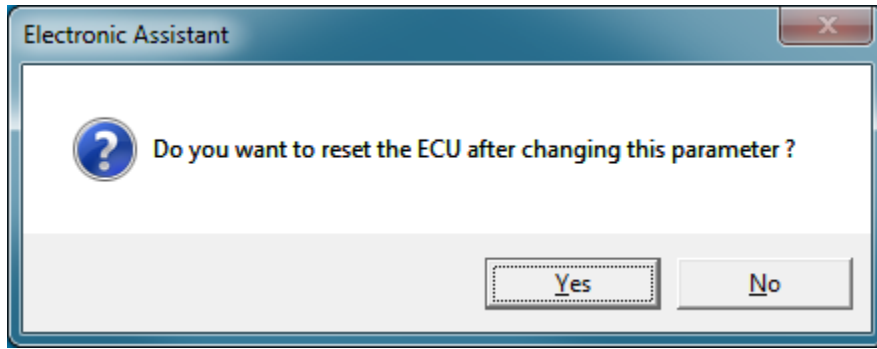

4. Upon reset, the ECU will no longer show up on the J1939 network as an AX021210 but rather as **J1939 Bootloader #1**.

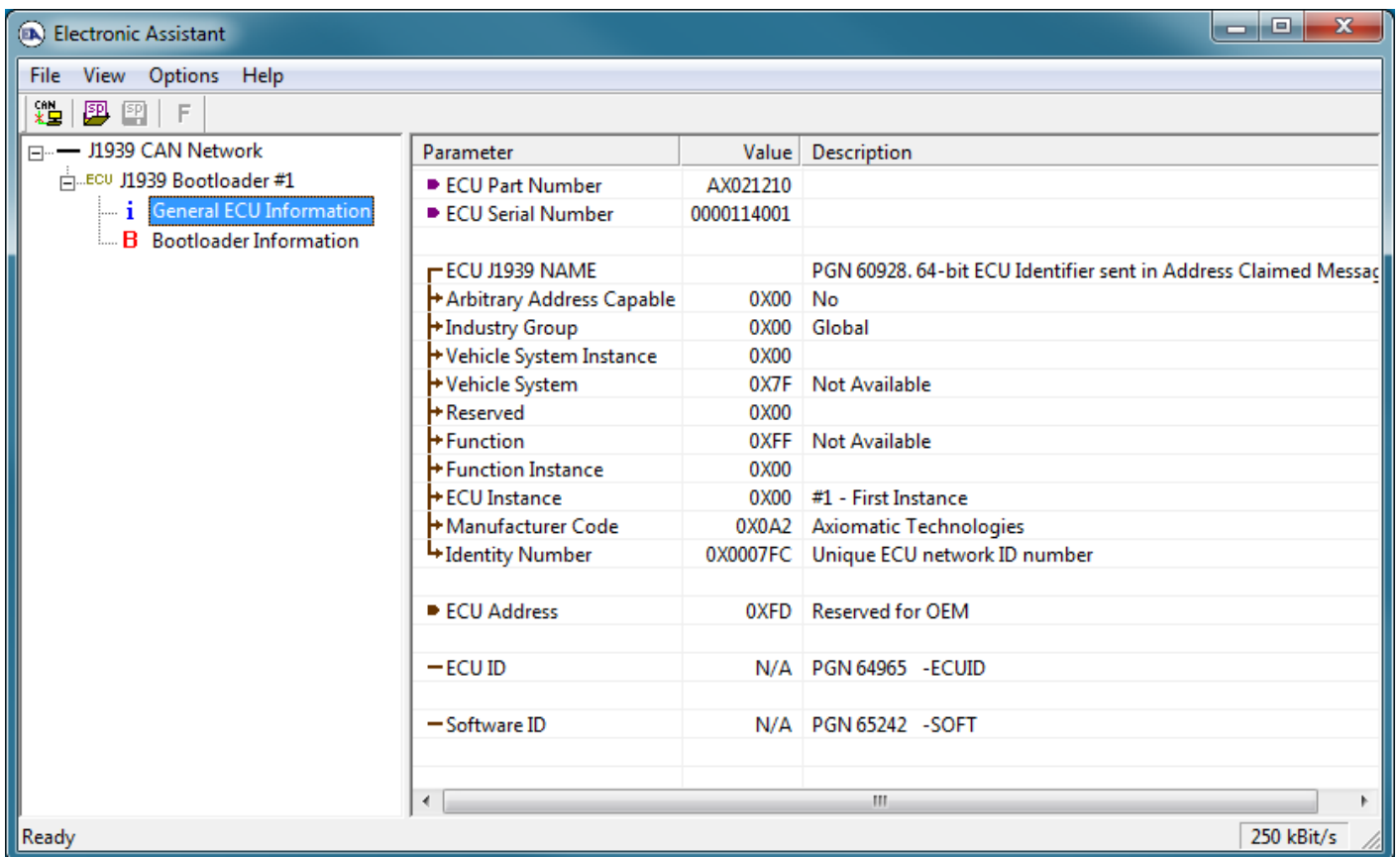
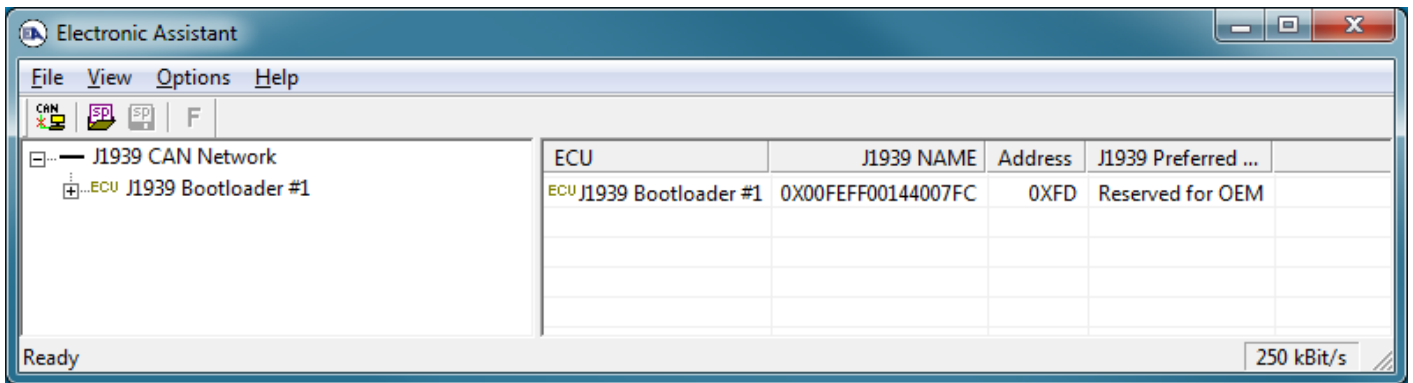

Note that the bootloader is NOT Arbitrary Address Capable. This means that if you want to have multiple bootloaders running simultaneously (not recommended) you would have to manually change the address for each one before activating the next, or there will be address conflicts. And only one ECU would show up as the bootloader. Once the 'active' bootloader returns to regular functionality, the other ECU(s) would have to be power cycled to re-activate the bootloader feature.

- When the **Bootloader Information** section is selected, the same information is shown as when it was running the AX021210 firmware, but in this case the **F**lashing feature has been enabled.

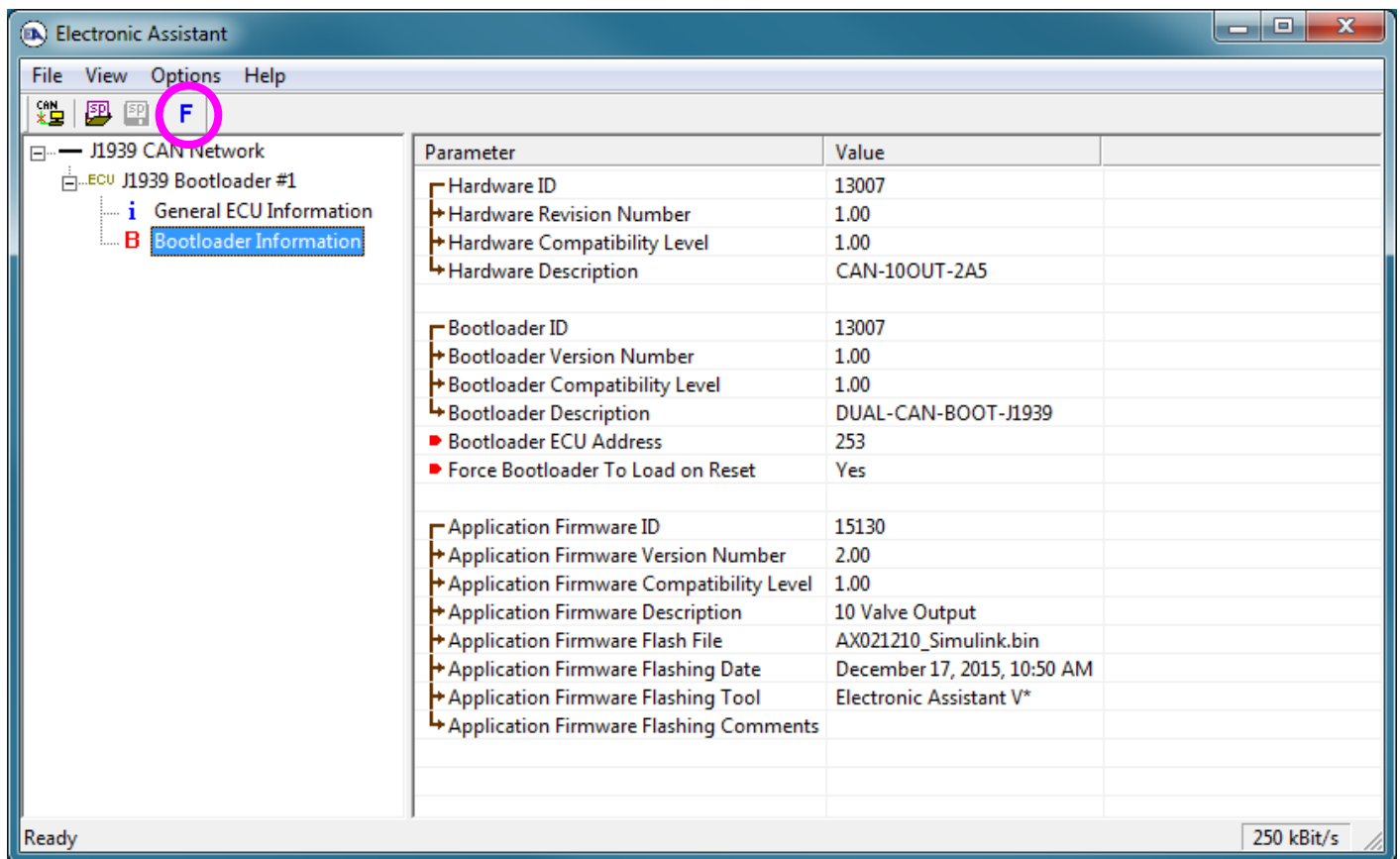

- Select the **F**lashing button and navigate to where you had saved the **AX021210_Simulink.bin** file sent from Axiomatic. (Note: only binary (.bin) files can be flashed using the EA tool.)
- Once the Flash Application Firmware window opens, you can enter comments such as "Firmware upgraded by [Name]" if you so desire. This is not required, and you can leave the field blank if you do not want to use it.

Note: You do not have to date/time-stamp the file, as this is done automatically by the EA tool when you upload the new firmware.

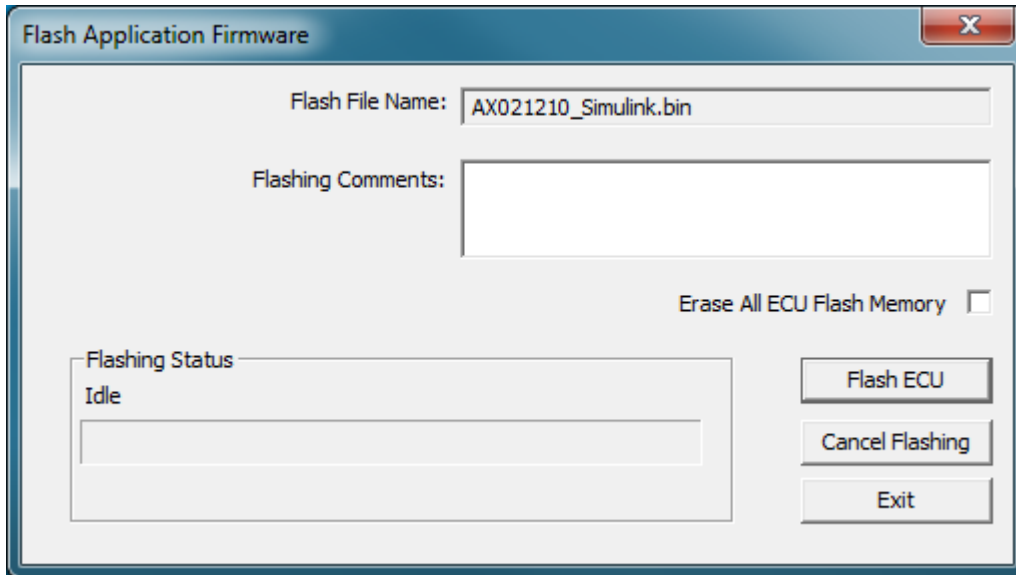

WARNING: Do not check the “Erase All ECU Flash Memory” box unless instructed to do so by your Axiomatic contact. Selecting this will erase ALL data stored in non-volatile flash including the calibration from Axiomatic factory testing. It will also erase any configuration of the setpoints that might have been done to the ECU and reset all setpoints to their factory defaults. By leaving this box unchecked, none of the setpoints will be changed when the new firmware is uploaded.

A progress bar will show how much of the firmware has been sent as the upload progresses. The more traffic there is on the J1939 network, the longer the upload process will take.

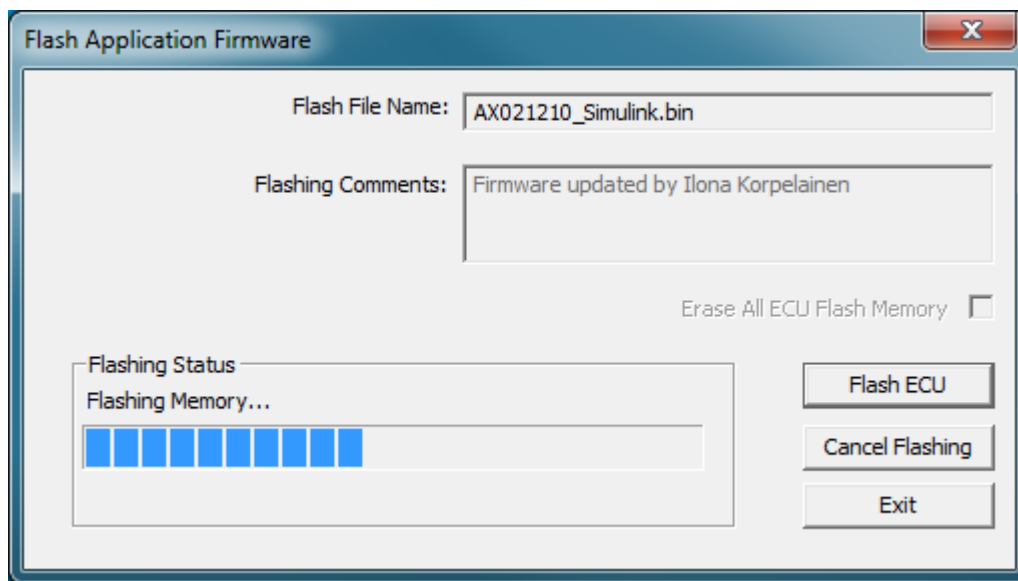

Once the firmware has finished uploading, a message will pop up indicating the successful operation. If you select to reset the ECU, the new version of the AX021210 application will start

running, and the ECU will be identified as such by EA. Otherwise, the next time the ECU is power-cycled, the AX021210 application will run rather than the bootloader function.

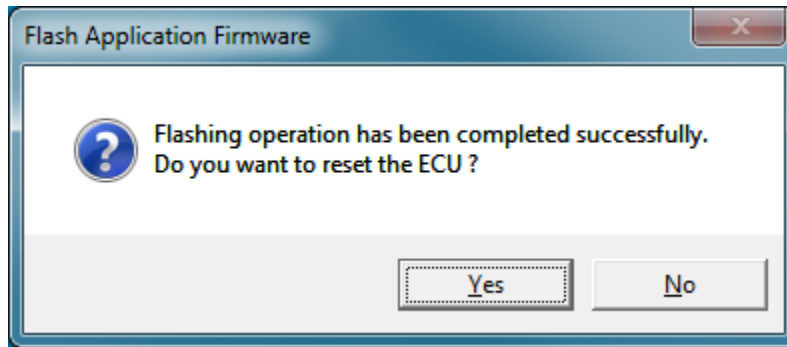

Note: If at any time during the upload the process is interrupted, the data is corrupted (bad checksum) or for any other reason the new firmware is not correct, i.e. bootloader detects that the file loaded was not designed to run on the hardware platform; the bad or corrupted application will not run. Rather, when the ECU is reset or power-cycled the **J1939 Bootloader** will continue to be the default application until valid firmware has been successfully uploaded into the unit.

APPENDIX A - TECHNICAL SPECIFICATION

Technical Specifications:

Specifications are indicative and subject to change. Actual performance will vary depending on the application and operating conditions. Users should satisfy themselves that the product is suitable for use in the intended application. All our products carry a limited warranty against defects in material and workmanship. Please refer to our Warranty, Application Approvals/Limitations and Return Materials Process as described on www.axiomatic.com/service.html.

Power Supply Specifications

Power Supply Input - Nominal	12Vdc or 24Vdc nominal (9...40Vdc) NB. The maximum total current draw permitted on the power supply input pins is 7 Amps @ 24VDC, at one time.
Protections	Surge and transient protection is provided. Reverse polarity protection is provided. Over-voltage protection is provided. Under-voltage protection is provided.
Supply Current	110 mA @ 12Vdc Typical; 60 mA @ 24Vdc Typical; 40 mA @ 48Vdc Typical

Input Specifications (Refer to the block diagram.)

Can commands (no physical inputs available)	SAE J1939 There are eleven setpoints per channel that are associated with the J1939 command message that is received by the controller from the network bus.
---	---

Output Specifications

Proportional Outputs	High side (sourcing) up to 2.5A Half-bridge output, current sensing, grounded load High frequency PWM (25 kHz) Fully independent, software controlled Ten outputs (0...2.5A) are user selectable as: <ul style="list-style-type: none"> • Output Disabled • Proportional Current (0...2.5A) • Hotshot Digital (0...2.5A, 0...10000 mSec.) • On/Off Digital (0...2.5A) Sourcing from power supply or output off • Proportional Voltage (0...60V) • PWM Duty Cycle (150Hz...5000Hz, 0 to 100%) Current outputs: 1 mA resolution Voltage outputs: 0.1V resolution PWM outputs: 0.1% resolution Digital on/off: Sourcing from power supply or output off (Note: Load at supply voltage must not draw more than 2.5A) NB. The maximum total current draw permitted on the power supply input pins is 7.0 Amps @ 24Vdc, at one time.
Output Adjustments	Digital Current: 0 to 2500 mA Hotshot Hold Time: 0 to 10000 ms Proportional Current: 0 to 2500 mA Proportional Voltage: 0 to 60V PWM Duty Cycle: 0 to 100% PWM Frequency: 150 Hz to 5000 Hz Ramp Up: 0 to 10000 ms Ramp Down: 0 to 10000 ms Dither Frequency: 50 to 400 Hz Dither Amplitude: 0 to 500 mA
Output Accuracy	Current outputs +/-1% Voltage outputs +/- 5% PWM outputs +/-0.1%
Protection	Overcurrent protection is provided on all outputs. Short circuit protection is provided all outputs. NB. Outputs are separately protected against short circuits to both power and GND. If the current at the output exceeds 6A, the protection circuitry will shut off the output signal, regardless of what type of output mode had been selected for that channel.
Error Conditions	If an error on the input is detected, the output of the controller shuts off. The controller can detect and flag open and short circuit loads, which can be read via the J1939 network for diagnostic purposes.

General Specifications

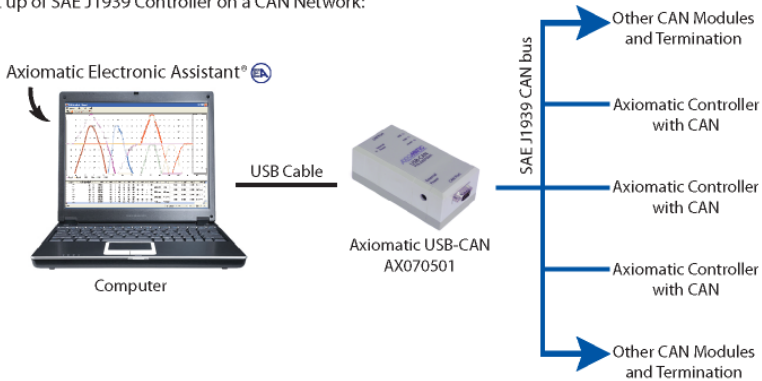
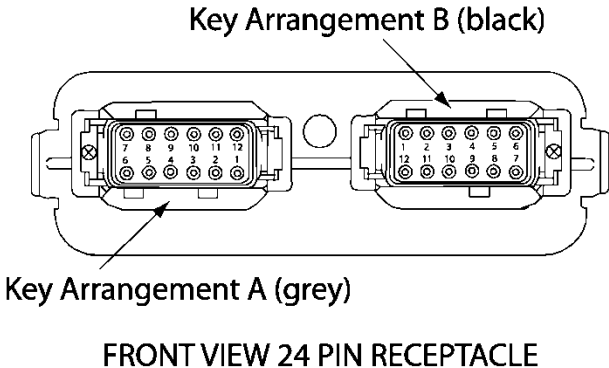
Operating Conditions	-40 to 85°C (-40 to 185°F)
Weight	0.60 lb. (0.27 kg)
Protection	IP67; Unit is conformal coated within the housing.
Microprocessor	STM32F205VGT6
Control Logic	Standard embedded software is provided.
User Interface	<p>User configuration and diagnostics are provided with the Axiomatic Electronic Assistant®, p/n AX070502. The Axiomatic Service Tool is a Windows-based graphical user interface that allows easy configuration of the controller setpoints.</p> <p>Set up of SAE J1939 Controller on a CAN Network:</p> 
Simulink® Block Library	<p>Model AX021210 includes a Simulink® block library. Simulink® is a model-based design tool from Mathworks®. Using Simulink®, the OEM machine designer may simulate their control system with the Axiomatic module included. This permits fine tuning of the design parameters and testing of functionality prior to machine prototype installation.</p> <p>The Hardware Interface Library for Simulink® is available from Axiomatic on request.</p>
Approvals	<p>CE marking Complaint to the EMC and RoHS Directives</p>
Network Termination	<p>It is necessary to terminate the network with external termination resistors. The resistors are 120 Ohm, 0.25W minimum, metal film or similar type. They should be placed between CAN_H and CAN_L terminals at both ends of the network.</p>
CAN Interface	1 CAN port (SAE J1939)
Electrical Connections	<p>Refer to the Installation section.</p> <p>Deutsch DTM series 24 pin receptacle (DTM13-12PA-12PB-R008) Mating plugs kits are available on request and include Deutsch DTM06-12SA and DTM06-12SB with 2 wedgelocks (WM12S) and 24 contacts (0462-201-20141). 20 AWG wire is recommended for use with contacts 0462-201-20141.</p>  <p style="text-align: center;">FRONT VIEW 24 PIN RECEPTACLE</p>



OUR PRODUCTS

Actuator Controls
Automotive Ethernet Converters
Battery Chargers
CAN bus Controls
CAN/Wifi, CAN/Bluetooth
Current/Voltage Converters
DC/DC Power Converters
Engine Temperature Scanners
Ethernet/CAN Converters, Switches
Fan Drive Controllers
Gateways, CAN/Modbus Protocols
Gyroscope Inclinometers
Hydraulic Valve Controllers
Inclinometers, Triaxial
I/O Controls
LVDT Simulators
Machine Controls
Modbus Controls
Motor Controls
Power Supplies
PWM Signal Converters/Isolators
Resolver Signal Conditioners
Service Tools
Signal Conditioners, Converters
Strain Gauge CAN Controls
Surge Suppressors

OUR COMPANY

Axiomatic provides electronic machine controls, components, and systems to the off-highway, commercial vehicle, electric vehicle, power generator set, material handling, renewable energy and industrial OEM markets.

We innovate with engineered and off-the-shelf machine controls that add value for our customers. We emphasize service and partnership with our customers, suppliers, and employees to build long term relationships and mutual trust.

QUALITY DESIGN AND MANUFACTURING

Axiomatic in Canada operates an ISO 9001:2015 registered design and manufacturing facility.

SERVICE

All products to be returned to Axiomatic require a Return Materials Authorization Number (RMA#). Please request an RMA# from sales@axiomatic.com.

Please provide the following information when requesting an RMA number:

- Serial number, part number
- Axiomatic invoice number and date
- Hours of operation, description of problem
- Wiring set up diagram, application
- Other comments as needed

All products should be serviced by Axiomatic. Do not open the product and perform the service yourself.

DISPOSAL

Axiomatic products are electronic waste. Please follow your local environmental waste and recycling laws, regulations and policies for safe disposal or recycling of electronic waste.

WARRANTY, APPLICATION APPROVALS/LIMITATIONS

Axiomatic Technologies Corporation reserves the right to make corrections, modifications, enhancements, improvements, and other changes to its products and services at any time and to discontinue any product or service without notice. Customers should obtain the latest relevant information before placing orders and should verify that such information is current and complete. Users should satisfy themselves that the product is suitable for use in the intended application. All our products carry a limited warranty against defects in material and workmanship. Please refer to our Warranty, Application Approvals/Limitations and Return Materials Process as described on www.axiomatic.com/service.html.

CONTACTS

Axiomatic Technologies Corporation
5915 Wallace Street
Mississauga, ON
CANADA L4Z 1Z8
TEL: +1 905 602 9270
FAX: +1 905 602 9279
www.axiomatic.com

Axiomatic Technologies Oy
Höytämöntie 6
33880 Lempäälä
FINLAND
TEL: +358 103 375 750
FAX: +358 3 3595 660
www.axiomatic.fi