



USER MANUAL UMAX021900

8 Input, 5 Output
VALVE CONTROLLER
With Programmable Logic

USER MANUAL

P/N: AX021900

In Europe:
Axiomatic Technologies Oy
Höytämöntie 6
33880 LEMPÄÄLÄ - Finland
Tel. +358 3 3595 600
Fax. +358 3 3595 660
www.axiomatic.fi

In North America:
Axiomatic Technologies Corporation
5915 Wallace Street
Mississauga, ON Canada L4Z 1Z8
Tel. 1 905 602 9270
Fax. 1 905 602 9279
www.axiomatic.com

VERSION HISTORY

Version	Date	Author	Modifications
1.0.0	September 28, 2009	Anna Murray	Initial Draft
1.1.0	March 11, 2010	Anna Murray	Minor corrections and updates after validation. Some clarification added to several function blocks. No changes to features or product.
1.2.0	May 14, 2010	Anna Murray	a) Removed reference on page 67 to updating the software filter for high frequency inputs to a moving average. This was no longer required after the input measuring function was improved in software V2.4.0. b) Updated accuracy information in Appendix B based on results of Validation Report.
2.0.0	December 7, 2010	Anna Murray	Added description for the new Math Function blocks.
2.0.1	July 3, 2015	Amanda Wilkins	Added vibration compliance.

ACCRONYMS

ACK	Positive Acknowledgement (from SAE J1939 standard)
DIN	Digital Input used to measure active high or low signals
DM	Diagnostic Message (from SAE J1939 standard)
DOUT	Digital Output, sourcing (high-side) output up to 2.5A current
DTC	Diagnostic Trouble Code (from SAE J1939 standard)
EA	Electronic Assistant  , p/n AX070502 (A Service Tool for Axiomatic ECUs)
ECU	Electronic Control Unit (from SAE J1939 standard)
FIN	Frequency Input used to measure Frequency, RPM or PWM signals
I/O	Inputs and Outputs
NAK	Negative Acknowledgement (from SAE J1939 standard)
PDU1	A format for messages that are to be sent to a destination address, either specific or global (from SAE J1939 standard)
PDU2	A format used to send information that has been labeled using the Group Extension technique, and does not contain a destination address.
PGN	Parameter Group Number (from SAE J1939 standard)
PropA	Message that uses the Proprietary A PGN for peer-to-peer communication
PropB	Message that uses a Proprietary B PGN for broadcast communication
PWM	Pulse Width Modulation
RPM	Rotations per Minute
SPN	Suspect Parameter Number (from SAE J1939 standard)
UIN	Universal Input used to measure voltage, current, resistive, frequency or digital inputs

UOUT

Universal Output, 0-2.5A current, digital, voltage or PWM type

TABLE OF CONTENTS

1. OVERVIEW OF CONTROLLER	7
1.1. Description of Valve Controller.....	7
1.2. Input Function Blocks.....	10
1.3. Output Functions Blocks.....	14
1.4. PID Control Function Block.....	22
1.5. Lookup Table Function Block.....	24
1.6. Programmable Logic Function Block.....	31
1.7. Math Function Block.....	37
1.8. Filtering Function Block.....	39
1.9. Diagnostic Function Block.....	41
1.10. DTC React Function Block.....	44
1.11. CAN Transmit Message Function Block.....	45
1.12. CAN Receive Message Function Block.....	47
1.13. Available Control/Input Sources.....	49
1.14. Default Valve Controller Program Logic.....	51
2. INSTALLATION INSTRUCTIONS	52
2.1. Dimensions and Pinout.....	52
2.2. Mounting Instructions	53
3. OVERVIEW OF J1939 FEATURES	54
3.1. Introduction to Supported Messages.....	54
3.2. NAME, Address and Software ID.....	55
3.3. CAN Transmit Messages Defaults.....	57
3.4. CAN Receive Messages Defaults.....	62
4. ECU SETPOINTS ACCESSED WITH ELECTRONIC ASSISTANT	65
4.1. Miscellaneous Setpoints.....	65
4.2. Universal Input Setpoints.....	66
4.3. Magnetic Pickup Setpoints.....	69
4.4. Digital Input Setpoints.....	70
4.5. Digital Output Setpoints.....	71
4.6. Output Drive Setpoints.....	72
4.7. Output Control Setpoints.....	74
4.8. Programmable Logic Setpoints.....	76
4.9. Math Function Setpoints.....	77
4.10. Lookup Table Setpoints.....	79
4.11. [Additional] Diagnostic Setpoints.....	80
4.12. DTC React Setpoints.....	81
4.13. CAN Transmit Setpoints.....	81
4.14. CAN Receive Setpoints.....	82
5. USING RS-232 WITH TERA TERM	84
5.1. Main Menu Options.....	85
5.2. Additional Debug Information.....	87
5.3. Changing CAN Baud Rate (RS-232 Only).....	90
5.4. Re-Flashing Instructions.....	91
APPENDIX A – Default Diagnostic Trouble Code Table	A
APPENDIX B – Technical Specifications	B

LIST OF FIGURES

1A. Hardware Functional Block Diagram.....	7
1B. Logical Functional Block Diagram.....	9
2. Universal Input Function Block.....	10
3. Digital Input Function Block.....	13
4. Digital Input Debouncing.....	13
5. Output Control Function Block.....	14
6. Linear Slope Calculations.....	14
7. Output Drive Function Block.....	17
8. Hotshot Digital Profile.....	18
9. Digital Output Function Block.....	20
10. Analog to Digital Input.....	20
11. PID Control Function Block.....	22
12. PID Control Algorithm.....	23
13. Lookup Table Function Block	24
14. Lookup Table Default Initialization Examples.....	27
15. Lookup Table “Jump To” Data Response.....	27
16. Lookup Table Examples to Setup for Joystick Deadband Response.....	28
17. Lookup Table Time Response Clutch Fill Profiles.....	29
18. Lookup Table “Soft Shift” EA Configuration.....	30
19. Programmable Logic Function Block	31
20. Programmable Logic Flowchart.....	33
21. Math Function Block.....	37
22. Software Data Filter Function Block.....	39
23. Diagnostics Function Block.....	41
24. DTC React Function Block.....	44
25. CAN Transmit Function Block.....	45
26. CAN Receive Function Block.....	47
27. Default Control Logic.....	51
28. Dimension Drawing.....	52

LIST OF TABLES

1. Universal Input Type Options.....	10
2. Voltage Input Ranges.....	11
3. Current Input Ranges.....	11
4. Frequency Input Ranges.....	11
5. PWM Input Range.....	12
6. Digital Input Type versus Input State.....	13
7. Enable Response Options.....	15
8. Fault Response Options.....	16
9. PID Responses.....	16
10. Output Types.....	17
11. Digital Control Responses.....	21
12. Digital Enable Responses.....	21
13. Conditional Operator Options.....	34
14. Condition Evaluation Results.....	34
15. Conditions Logical Operator Options.....	35
16. Conditions Evaluation Based on Selected Logical Operator.....	35
17. Programmable Logic Block Default Lookup Tables.....	36
18. Math Function Operators.....	38
19. Software Filter Types.....	39
20. Fault Detect Thresholds.....	42
21. Low Fault FMI versus High Fault FMI.....	44
22. Default CAN Transmit Messages.....	46
23. Default CAN Receive Messages.....	48
24. Programmable Inputs.....	49
25. Input Sources and Numbers.....	50
26. Connector Pinout.....	52

REFERENCES

J1939	Recommended Practice for a Serial Control and Communications Vehicle Network, SAE, October 2007
J1939/21	Data Link Layer, SAE, December 2006
J1939/71	Vehicle Application Layer, SAE, January 2009
J1939/73	Application Layer-Diagnostics, SAE, September 2006
J1939/81	Network Management, SAE, May 2003
TDAX021900	Technical Datasheet, 8 In, 5 Valve Controller
UMAX07050x	User Manual, Electronic Assistant and USB-CAN, Axiomatic Technologies, November 2008

This document assumes the reader is familiar with the SAE J1939 standard. Terminology from the standard is used, but is not described in this document.



NOTE: When a description is in “**double-quotes**” and bolded, this refers to the name of a user configurable setpoint (variable). If it is in ‘*single-quotes*’ and italicized, it refers to an option for the associated setpoint.

For example: “**Input Sensor Type**” set to ‘*Current*’



This product uses the Axiomatic Electronic Assistant[®]  to program the setpoints for application specific requirements. After configuration, the setpoints can be saved in a file which could then be flashed into other AX021900 controllers over the CAN network.

One point to note is that due to the fact that the controller automatically updates some defaults when some setpoints are changed, it may be required to reflash the same file a second time. This will update correctly some setpoints that may have been automatically overwritten during the first reflashing process.

1. OVERVIEW OF CONTROLLER

1.1. Description of Valve Controller

The 8 Input, 5 Output Valve Controller (8i5o) is designed for extremely versatile control of up to four proportional outputs to directly drive coils or other loads. Its flexible circuit design gives the user a wide range of configurable input or output types. The sophisticated control algorithms allow the user to program the controller for a wide range of applications without the need for custom software.

The controller has six fully programmable universal inputs that can be setup to read: voltage; current; resistive; frequency; or digital input signals. For added flexibility, it also has a magnetic sensor circuit that can read AC signals and convert them into a frequency (RPM) pickup. Lastly, there is an eight digital input that can be used for global enable/disable or overrides of one or all of the outputs.

There are four universal outputs that can be setup to drive: proportional current (up to 2.5A each); hotshot digital current; proportional voltage (up to supply); proportional PWM; or straight on/off digital loads. For applications requiring a fifth digital output, there is also one high-side (sourcing) output for up to a 2.5A digital load.

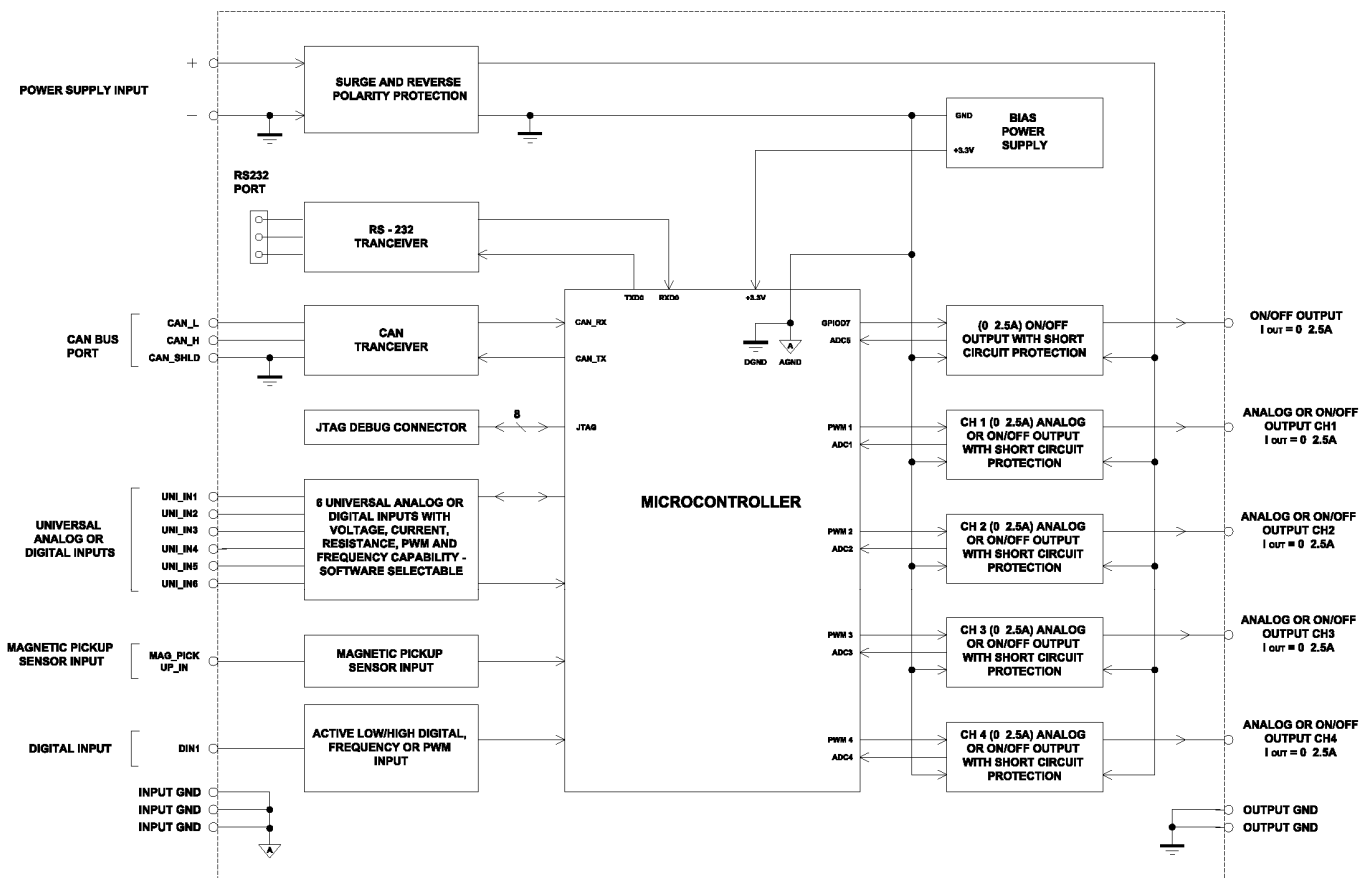

Figure 1A – Hardware Functional Block Diagram

The 8i5o is a highly programmable controller, allowing the user to configure it for their application. Its sophisticated control algorithms allow for open or closed loop drive of the proportional outputs. It can be operated as either a self-contained control system, driving the outputs directly from the on-board inputs, and/or it can be integrated into a CAN J1939 network of controllers. All I/O and logical function blocks on the unit are inherently independent from one another, but can be programmed to interact in a large number of ways. While Figure 1A shows the hardware features, Figure 1B shows the logical function blocks (software) available on the 8i5o.

The 8i5o has a number of built-in protection features that can shutoff the outputs in adverse conditions. These features are described in detail in section 1.9 Table 20 and they include hardware shutoffs to protect the circuits from being damaged as well as software shutdown features that can be enabled in safety critical systems.

The various function blocks supported by the 8i5o are outlined in the following sections. All setpoints are user configurable using the Electronic Assistant ® as outlined in Section 4 of this document.

- Yellow bubbles represent setpoints that are unique to the function block in question
- Green bubbles represent the inputs to the function block
- Grey (light purple) bubbles represent outputs from the function block that can be mapped as inputs to other function blocks
- Blue bubbles represent another function block supported by the ECU which is intrinsically linked to the function block in question.
- Red bubbles represent outputs from the function block that are used internally in the controller by other function blocks, but are not accessible to the user.
- Dark purple bubbles represent messages that are sent to or received from the CAN bus.

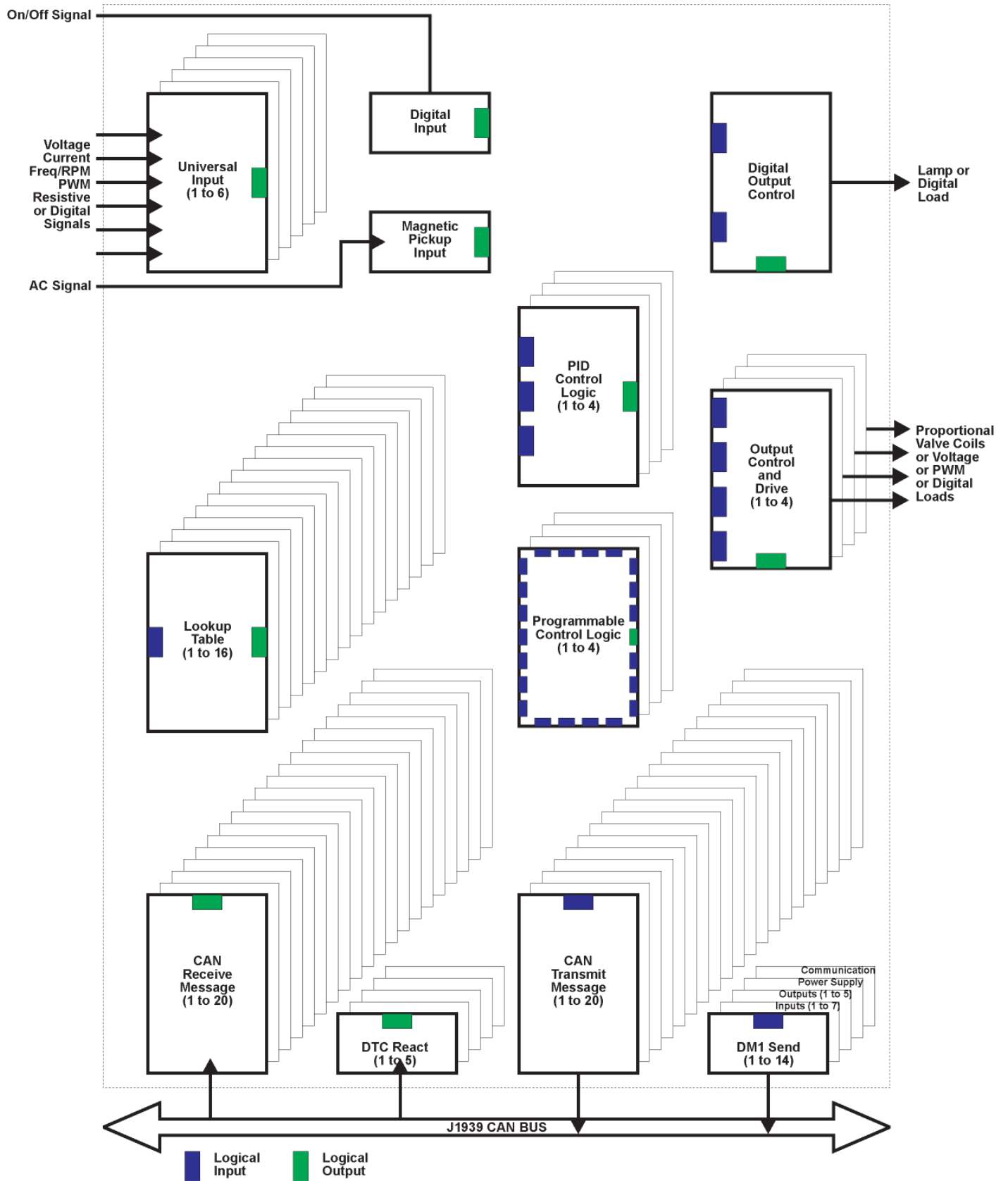

Figure 1B –Logical Functional Block Diagram

1.2. Input Function Blocks

Technically, there are three types of input function blocks, one for a Universal Input, one for the Magnetic Pickup, and a third for the Digital inputs. In reality, however, the Magnetic Pickup uses the exact same function block as the Universal Input, except that the input type is fixed as a frequency/RPM input.

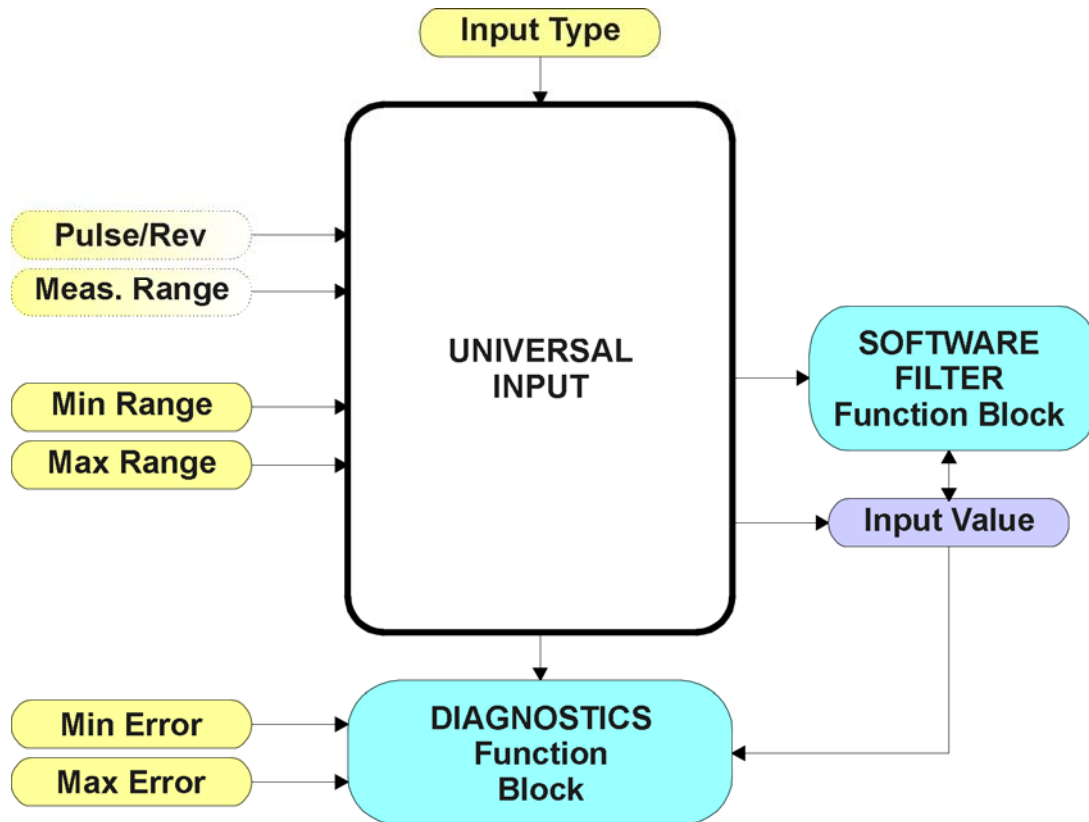



Figure 2 – Universal Input Function Block

The “**Input Sensor Type**” is the most important setpoint associated with this function block, and it should be selected first. Changing it will result in other setpoints being automatically updated to new default values by the 8i50 to match the new type.

0	<i>Disabled</i>
1	<i>Voltage (Default)</i>
2	<i>Current</i>
3	<i>Resistive</i>
4	<i>Freq/RPM</i>
5	<i>PWM</i>
6	<i>Digital</i>

Table 1 – Universal Input Type Options



If the input is used as a control input into another function block (i.e. PID, Table or Output Control), the corresponding function block will also be update when the Input Type (or min/max) value is changed to reflect the new defaults.

Voltage (0-5V) or Current (0-20mA) inputs have a hardware filter which then goes directly to the pin of a 12-bit analog-to-digital converter (ADC). A voltage input is a high impedance (50kΩ) input protected against shorts to GND or Vcc. In current mode, a 125Ω resistor is used to measure the input signal. Analog Inputs should be connected to the AGND reference pins provided on the connector.

Frequency/RPM or Pulse Width Modulated (PWM) inputs are connected to 16-bit timer pins on the processor. The same pin can be used to reflect an active high digital input (connected to a +Vcc source).

Resistive inputs can accurately read a resistive value connected between the input pin and AGND. The 8i50 controller multiplexes a configurable current source (10uA, 100uA, 1mA or 10mA) to each pin setup as a resistive input, and measures the voltage created across the input. Depending on the value of the load on the input pin, it will self-calibrate to the appropriate sourcing current and adjust internal gain amplifiers. In this way, resistances from 30 Ω to 250 kΩ can be measured. Values outside of this range are automatically read as either a short or open circuit on the input.

The “**Pulse Per Revolution**” setpoint is only associated with the frequency input type. If a non-zero Pulse/Rev is selected, then the input data will be reported as in rotations-per-minute (RPM). Otherwise, frequencies inputs are measured in Hertz.

The “**Input Measuring Range**” setpoint is not used with resistive (self-calibrating) or digital inputs. For all other types, this setpoint is enabled to allow the user to optimize the hardware for the input signal.

For voltage inputs, there are actually four input ranges that can be selected. Typically, inputs will be in either the 0-5V or 0-10V range, but for more resolution at smaller voltages, a low range can be selected when appropriate.

0	0 to 1V
1	0 to 2.5V
2	0 to 5V
3	0 to 10V

Table 2 – Voltage Input Ranges

For current inputs, both ranges are the same at the hardware level. However, in 4-20mA, the minimum value cannot be set below 4mA.

0	0 to 20mA
1	4 to 20mA

Table 3 – Current Input Ranges

For frequency inputs, the user can select the following ranges shown in Table 4. Beside it, the overflow values are shown, showing how long it would take to flag an error once the signal is lost (i.e. no frequency measured.)

0	0.5Hz to 50Hz	Overflow [Sec]
1	10Hz to 1kHz	~2.510
2	100Hz to 10kHz	~0.140
		~0.012

Table 4 – Frequency Input Ranges

The means by which the frequency is calculated is by measuring the time between pulses. The advantage of this type of measuring technique is that it gives an accurate reading of low frequency signals, with 2 decimal places of resolution. However, it has a drawback in that it will take several seconds to detect a loss of signal when the pulses go away, and may be read as a very high frequency signal during the transition phase. Therefore, it is highly recommended that diagnostics on low frequency inputs are not sent to the network for at least 5 seconds, to ensure that a low signal error is flagged, not a high error. If a signal will never go below 10Hz, it is highly recommended to use a more appropriate range for faster error reaction.

For PWM Inputs, there are only two types of measuring ranges, as shown below. To guarantee the rated accuracy of +/- 1% from 1% to 99%, ensure that the appropriate measuring range is selected.

0	Low Freq (<1kHz)
1	High Freq (>100Hz)

Table 5 – PWM Input Ranges

The “**Minimum Range**” and “**Maximum Range**” setpoints must not be confused with the measuring range. These setpoints are available with all but the digital input, and they are used when the input is selected as a control input for another function block. They become the Xmin and Xmax values used in the slope calculations (see Figure 6). When these values are changed, other function blocks using the input as a control source are automatically updated to reflect the new X-axis values.

The “**Minimum Error**” and “**Maximum Error**” setpoints are used with the Diagnostic function block. The values for these setpoints are constrained such that

$$0 \leq \text{Minimum Error} \leq \text{Minimum Range} \leq \text{Maximum Range} \leq \text{Maximum Error} \leq 1.1 \times \text{Max}^*$$

* The maximum value for any input is dependent on type. The error range can be set up to 10% above this value.

Frequency:	Max = 10,000 [Hz or RPM]
PWM:	Max = 100.00 [%]
Voltage:	Max = 1.00, 2.50, 5.00 or 10.00 [V]
Current:	Max = 20.00 [mA]
Resistive	Max = 250 [kΩ]

Lastly, the user can choose to use a Software Filter on the measured input prior to using it for diagnostic or control purposes.

More information about the Diagnostic or Software Filter function blocks can be found in Sections 1.9 and 1.8 respectively.

Since a Universal Input could be configured to act as an extra digital input, the Digital Input Function Block would take over when the “**Input Sensor Type**” is set to ‘*Digital*’. When using it as an input to another function block (i.e. an Enable signal), map the control to the ‘*Digital Input Read State*’ type instead of the ‘*Universal Input Measured*.’ The associated control number would still be set for the same as the universal input type. (i.e. Uin1 = Din1).

Because of this feature, the dedicated Digital Input is considered to be the eighth input, so it is ‘Digital Input 8’ in the EA.

In contrast to the analog input types, the digital input function is very simple, as shown below.

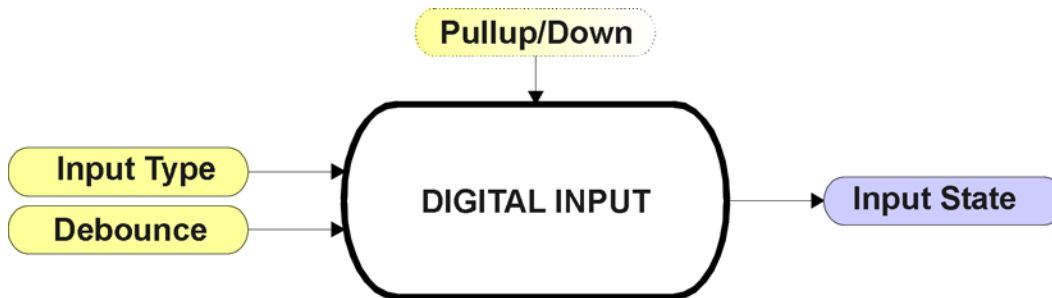

Figure 3 – Digital Input Function Block

The digital inputs connected to the Universal Inputs, Din1 to Din6, are all active high. This means that when the input signal on the pin goes HIGH (>3V), the normal state response of the input is that it is ON. When nothing or a low (GND) is connected to the pin, the input is OFF.

The extra digital input, Din8, however, can be configured to connect an internal 10kΩ resistor to either GND (pulldown) or +5V (pullup). In this case, an active high or active low input can be used.

To prevent spurious signals from affecting the logic of the controller, all digital inputs have associated with them a debounce time. If and only if the signal at the end of the debounce period has changed state will the change of state of the input be translated to the controller. The “**Debounce Period**” setpoint can be selected with 1ms resolution up to 1 second.

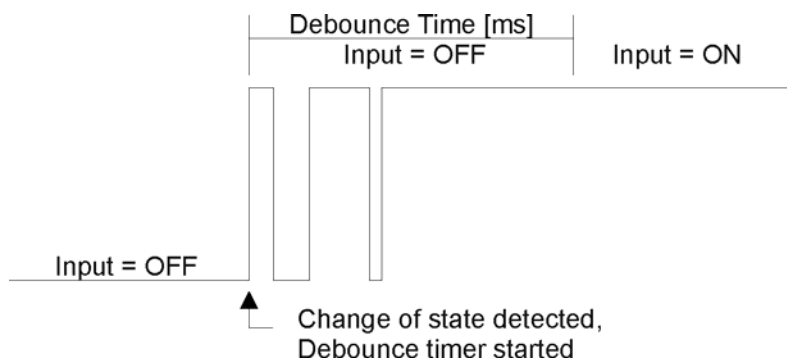

Figure 4 – Digital Input Debouncing

The “**Digital Input Type**” setpoint determines the Input State used by other function blocks based on the actual state of the active high input per the table below.

		Active High	Active Low	State
0	Normal On/Off	HIGH	LOW	ON
		LOW or Open	HIGH or Open	OFF
1	Inverse Logic	HIGH	LOW	OFF
		LOW or Open	HIGH or Open	ON
2	Latched Logic	HIGH to LOW	LOW to HIGH	No Change
		LOW to HIGH	HIGH to LOW	State Change (i.e. OFF to ON)

Table 6 – Digital Input Type versus Input State

1.3. Output Function Blocks

There are three types of output function blocks, one for proportional output drive, the next for proportional output control, and the last for digital output control.

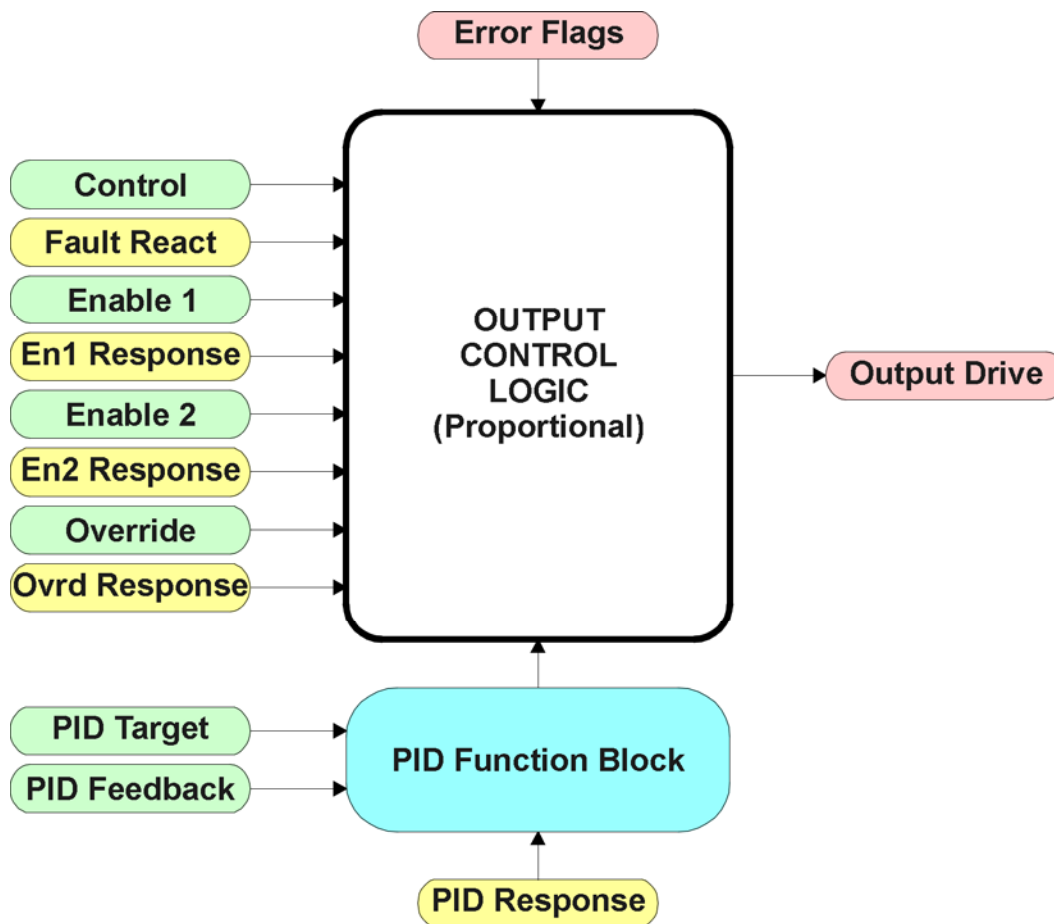

Figure 5 – Output Control Function Block

The Output Control Logic and the Output Drive function blocks are linked. The control signal, whether an on-board input, a CAN command, a lookup table, or a PID block, will have associated with it a minimum and maximum value. Depending on what type of control input is selected, the output will respond in a linear fashion to changes in the input per the calculation in Figure 6.

$$y = mx + a$$

$$m = \frac{Y \text{ max} - Y \text{ min}}{X \text{ max} - X \text{ min}}$$

$$a = Y \text{ min} - m * X \text{ min}$$

Figure 6 – Linear Slope Calculations

In the case of the Output Control Logic function block, X and Y are defined as

Xmin = Control Input Minimum Ymin = “**Output at Minimum Command**”
Xmax = Control Input Maximum Ymax = “**Output at Maximum Command**”

In all cases, while the X-axis has the constraint that Xmin < Xmax, there is no such limitation on the Y-axis. This allows for a negative slope, whereby as the control input signal increases, the target output value decreases.

By default, the Output X “**Control Source**” is setup to be ‘*Lookup Table X*’ which is in turn setup for a linear response to Universal Input X, where X = 1 to 4. In other words, all the proportional outputs will respond in a linear fashion to the corresponding input. (i.e. Input 1 controls Output 1)

In addition to the Control input, the function block also supports two enable inputs which can be setup as either enable or disable signals. If both signals are used as an enable, BOTH must be ON before the output will be engaged. Otherwise, the output will be shutoff as per the “**Enable X Response**”. If one or both are used as a disable signal, if EITHER input is ON, the output will be shutoff. In both cases, Enable 1 will be evaluated first, and only if it is enabling the drive will Enable 2 be looked at. This feature can be used for safety interlocking, i.e. the user must squeeze a trigger on a joystick to enable the coil, but the valve will not engage if a limit switch has been triggered.

0	<i>Enable When On, Else Shutoff</i>
1	<i>Enable When On, Else Rampoff</i>
2	<i>Enable When Off, Else Shutoff</i>
3	<i>Enable When Off, Else Rampoff</i>
4	<i>Enable When On, Else Ramp To Min</i>
5	<i>Enable When On, Else Ramp To Max</i>

Table 7 – Enable Response Options

Another feature of the Enable inputs is that they can also be mapped to react to a diagnostic trouble code (DTC) sent by another ECU on the network via a DM1. In this case, the “**Enable X Source**” would be a ‘*Diagnostic Trouble Code (Rxd)*’, and the response would be setup as a disable signal.

The Override option allows the user to have the output drive go to a default value in the case of the override input being engaged/disengaged.

The Enable 1, Enable 2, and Override commands can be mapped to either a CAN message or any input. By default, though, the 8i50 assumes a digital input will be used for all of these inputs. If a non-digital control is selected, the input will be interpreted per Figure 10.

If an output is being controlled by an on-board input, and a fault is detected at the input, then the output will respond per the “**Fault Response**” setpoint. This is also true when controlled by a CAN message that is not received within the expected update timeframe (lost communication error).

0	<i>Shutoff</i>
1	<i>Ramp Off</i>
2	<i>Ramp to Min</i>
3	<i>Ramp to Max</i>
4	<i>Ramp to Override</i>

Table 8 – Fault Response Options

Another fault response that can be selected is that a power supply over voltage or under voltage will automatically disable ALL outputs. Note: this setpoint is associated with the Power Supply Diagnostic function block.

Should a fault response occur, the output drive will remain in that state until the condition(s) causing the fault reaction has disappeared.

The outputs are inherently protected against a short to GND by circuitry. In the case of a dead short to GND, the hardware will automatically disable the output drive, regardless of what the processor is commanding for the output. Should this happen, the processor might flag an open-circuit error on the output instead of a short, as the feedback to the processor will be ~0mA.

To enable a PID response for an output, simply set the “**Control Source**” to the ‘*PID Function Block.*’ In the case of the PID blocks, each one is hard-coded directly to the corresponding output number, and is not user configurable.

In this case, the “**PID Target Command Source**” determines the control input, and the “**PID Feedback Input Source**” established the feedback signal to the PID function block.

Also, the Output X Control has an additional setpoint associate with the PID called “**PID Response Profile**” The options for this setpoint are listed in Table 8.

0	<i>Single Output</i>
1	<i>Setpoint Control</i>
2	<i>On When Over Target</i>
3	<i>On When Below Target</i>

Table 9 – PID Responses

In all closed-loop control methods, there are also two types of control available. One method, option 0, is where the PID target is calculated based on a linear relationship between the control input and the target settings as described in Figure 6. The other control option 1, though, is a setpoint control, where the PID loop will adjust the output drive such that the feedback signal always matches the “**PID Setpoint Control Target**”

The last two options, 2 and 3, are designed to allow the user to combine the two proportional outputs as a push-pull drive for a system. Both outputs must be setup to use the same control input (linear response) and feedback signal in order to get the expected output response.

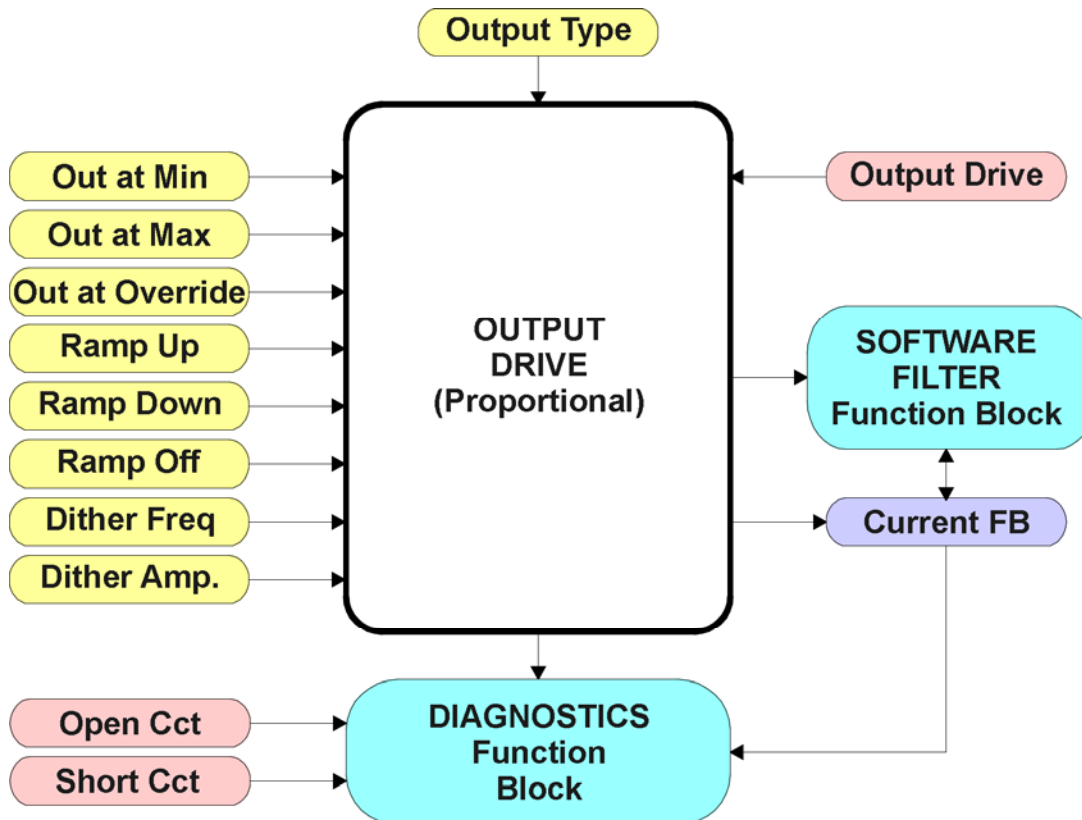

**Note: In Hotshot mode, Out at Min = Hold Current
Out at Max = Hotshot Current, and Ramp Up = Hold Time**

Figure 7 – Output Drive Function Block

The “**Output Type**” is the most important setpoint associated with this function block, and it should be selected first. Changing it will result in other setpoints being automatically updated by the 8i50 to match the new type. There are several output types supported, as outlined in Table 10.

0	<i>Disabled</i>
1	<i>Proportional Current</i>
2	<i>Digital Hotshot</i>
3	<i>PWM Duty Cycle</i>
4	<i>Proportional Voltage</i>
5	<i>Digital On/Off</i>

Table 10 – Output Types

For the ‘*Proportional Current*’ or ‘*Hotshot Digital*’ types, the unit for the output values is Amps, and the Software Filter and Diagnostic function blocks related to the current feedback are used. For all other output types, these setpoints are ignored.

Any of the proportional responses (current, duty cycle or voltage) react to the Control input in a linear fashion per the relationship in Figure 6.

In order to prevent abrupt changes at the output due to sudden changes in the command input, the user can choose to use the independent up or down ramps to smooth out the coil's response. The **"Ramp Up"** and **"Ramp Down"** setpoints are in milliseconds, and the step size of the output change will be determined by taking the absolute value of the output range and dividing it by the ramp time.



If the output is being controlled by a Lookup Table function block in the "Time Response" mode, the user should disable the output drive ramps (set them to zero) as the table will already ramp the command before it is applied to the output drive.

The *'Proportional Current'* type has associated with it two setpoints not used by the other types, which are the **"Dither Frequency"** and **"Dither Amplitude"** values. The output is controlled by a high frequency signal (25kHz), with the low frequency dither superimposed on top. The dither frequency will match exactly what is programmed into the setpoint, but the exact amplitude of the dither will depend on the properties of the coil.

When adjusting the dither amplitude value, select one that is high enough to ensure an immediate response to the coil to small changes in the control inputs, but not so large as to effect the accuracy or stability of the output.

Instead of proportional, there are two types of digital responses possible as well. With the *'Digital On/Off'* type, should the control require the output to be on, it will be turned on at whatever the system power supply is. The output will source whatever current is required by the load, up to 2.5A.

The *'Hotshot Digital'* is different in that it still controls the current through the load. This type of output can be used to turn on a coil, then reduce the current so that the valve will remain open, but less energy is used.

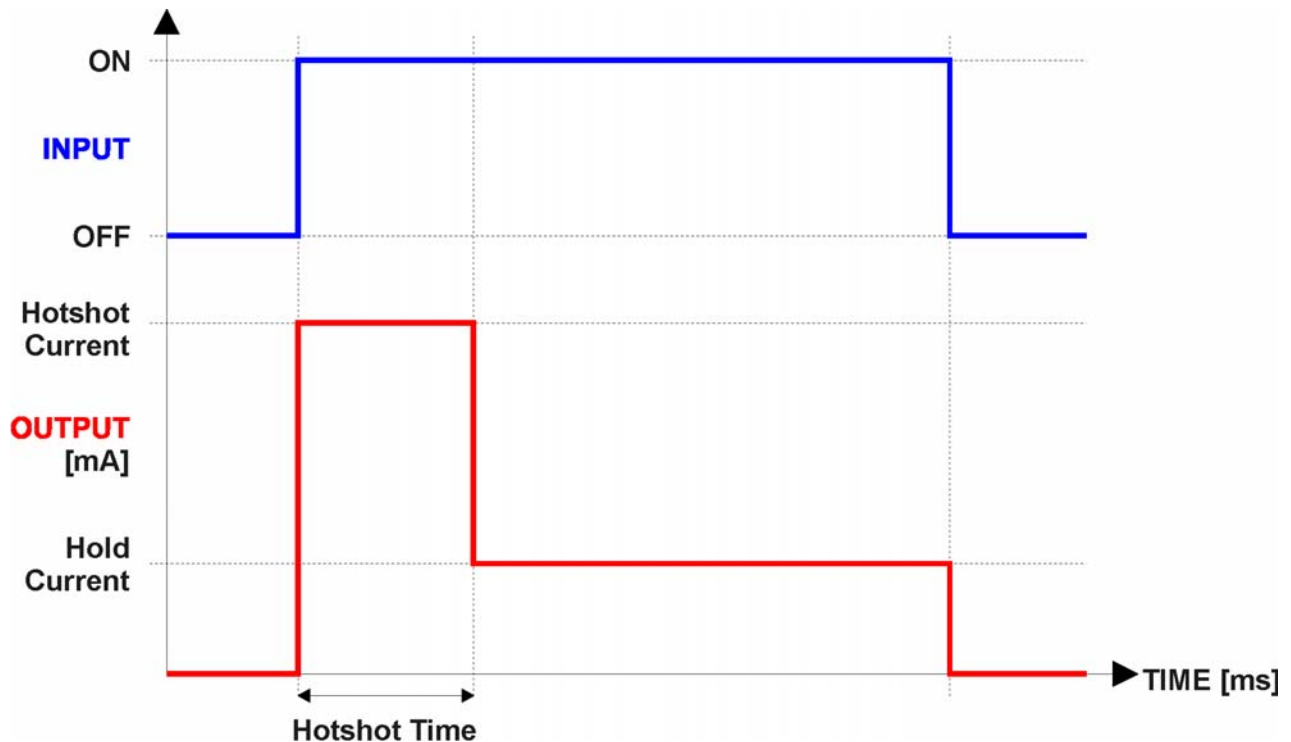

Figure 8 – Hotshot Digital Profile

The *'Proportional Voltage'* type uses the measured value of the power supply, and adjusts the duty cycle of the output such that the average value will match the target output voltage. Since the output is running at a high frequency (25kHz), the voltage can be easily average using a simple low pass filter.

Normally, for this type of output, the *'PWM Duty Cycle'* option allows the user to run the output at a fixed low frequency (i.e. <1kHz) while the duty cycle changes depending on the Control input. However, since the PWM peripheral for the drive is used by all four outputs, the output frequency for this outputs remains fixed at 25kHz so long as even one output is setup for current or voltage control. In these cases, there is not much difference between the Voltage or PWM outputs in the product.

If and only if ALL FOUR outputs are setup for PWM (or Digital On/Off) will the frequency of lowest PWM output be used.

Unlike the proportional outputs, the digital 2.5A output has only a Control and single Enable input.

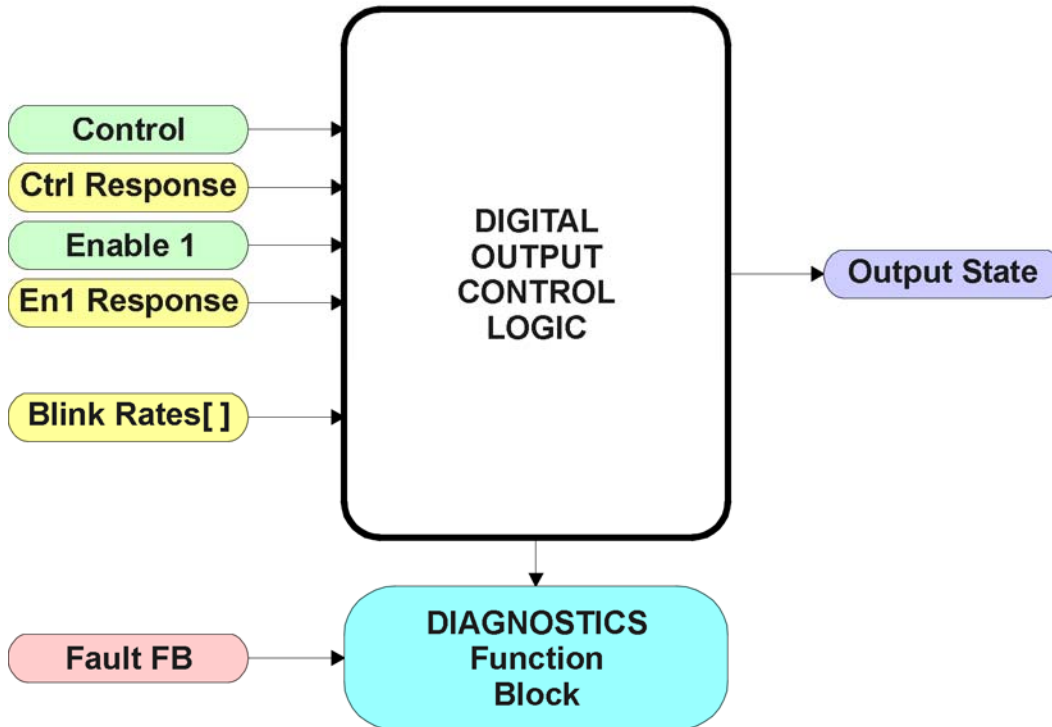

Figure 9 – Digital Output Function Block

Since this is a digital output, it is assumed that the “**Control Source**” will be a digital input, as will the “**Enable 1 Source**.” If a non-digital control is selected, the command state will be OFF at or below the minimum input, ON at or above the maximum input, and it will not change in between those points. In other words, the input will have built in hysteresis, as shown in Figure 10. This relationship is true for any function block that has a non-digital input mapped to a digital control .

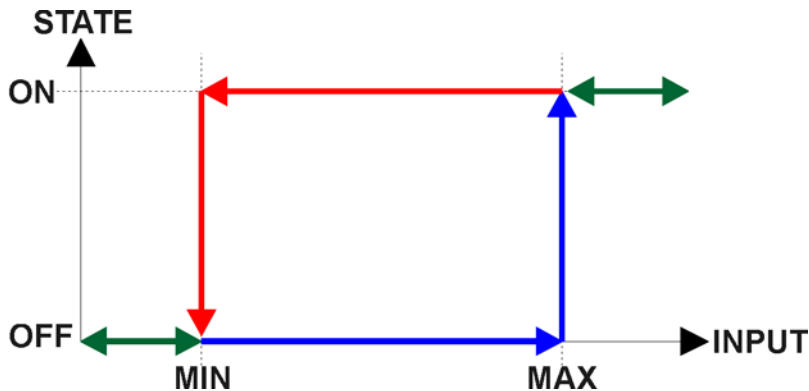

Figure 10 – Analog to Digital Input

Unlike the other (proportional) outputs, the Digital Output control block has unique responses to the Control and Enable inputs. Control Responses and Enable Responses are shown in Tables 11 and 12 respectively.

0	<i>Disabled</i>
1	<i>Blinking</i>
2	<i>Normal</i>
3	<i>Inverse</i>
4	<i>Latched</i>

Table 11 – Digital Control Responses

0	<i>Dout On If Ctrl Or Enable On</i>
1	<i>Dout On If Ctrl And Enable On</i>
2	<i>Dout On If Uout1 or Uout2 On</i>
3	<i>Dout On If Uout3 or Uout4 On</i>
4	<i>Dout On When Any Uout On</i>

Table 12 – Enable Control Responses

Unlike the other control blocks, the “**Enable Response**” here can actually drive the output state directly. If a selection of 2 or higher is used, then the “**Control Source**” and “**Enable Source**” inputs are ignored. However, the actual response of the output to the commanded state will still be dependent on the “**Control Response**” selected, so be sure to use the ‘*Normal*’ response in these cases.

Otherwise, if an “**Enable 1 Source**” is selected, and one of the first two responses is used, the enable input is either OR’ed or AND’ed with the control input to establish the desired output state. When this kind of logic is used, the “**Control Response**” setpoint will determine the actual output state to the commanded state.

In a ‘*Normal*’ response, when the Control and/or Enable input commands the output ON, then the output will be turned ON. However, in an ‘*Inverse*’ response, the output will be ON unless the input(s) commands the output ON, in which case it turns OFF.

If a ‘*Blinking*’ response is selected, then while the input(s) command the output ON, it will blink at the rate in the “**Input Fault Blink Rate**” setpoint. When commanded OFF, the output will stay off.

If a ‘*Latched*’ response is selected, when the input(s) command the state from OFF to ON, the output will change state.

The Digital Output function block is also unique in that the “**Control Source**” here can be selected to ‘*Reflect When a Fault is Detected*’. In this case, the enable input and response is ignored. This option allows the digital output to be setup as an Error Lamp, which will blink at different rates should a fault be flagged. The output has associate with it three blink rates for this mode to reflect “**Output**”, “**Input**” or “**Other**” faults.

1.4. PID Control Function Block

The PID Control function block is associated with proportional output control blocks as described earlier. When the control logic for an output has been setup for closed-loop control (refer to relevant section for more information about how this is done), the output of its PID control function block effectively becomes the command input to the respective output drive.

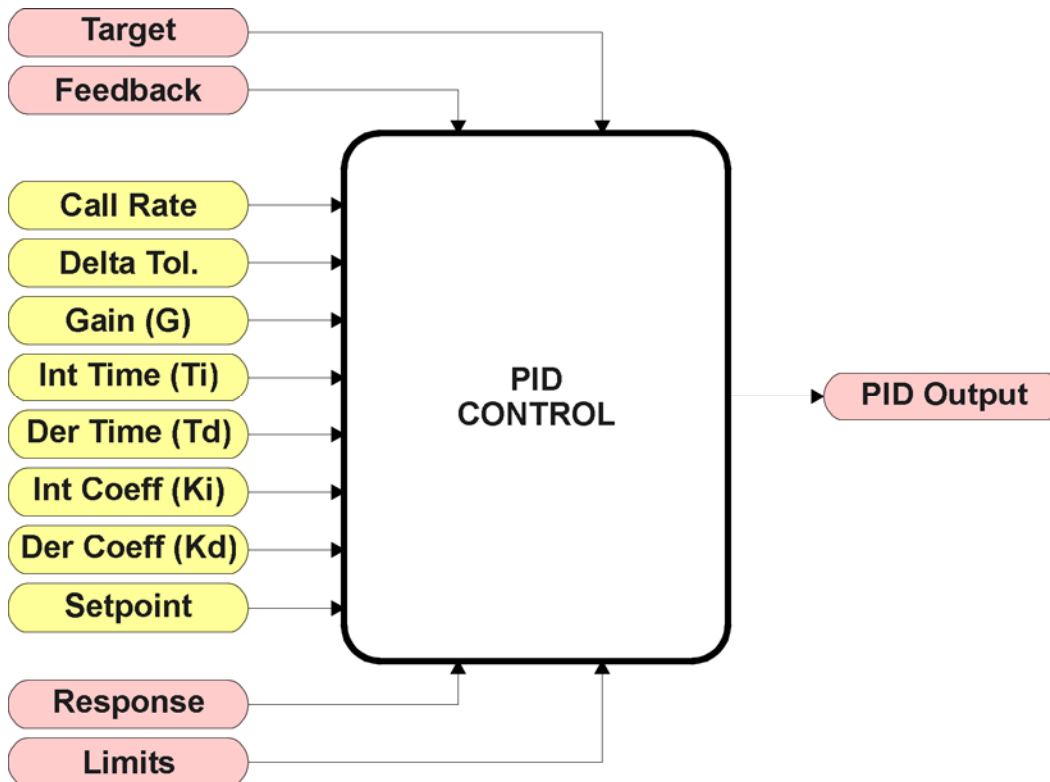

Figure 11 – PID Control Function Block

As the PID functions are intrinsically tied to a particular drive, the target and feedback inputs are determined by the associated control block. The response type is also derived from the control block function, as are the limits on the PID output value.

When active, the PID algorithm will be called every “**PID Loop Update Rate**” (in ms)

In order to allow the output to stabilize, the user can select a non-zero value for “**PID Delta Tolerance**”. If the absolute value of $Error_K$ is less than this value, $Error_K$ in the formula below will be set to zero.

The PID algorithm used is shown below, with names in red being the configurable parameters.

```
T = Loop_Update_Rate*0.001

P_Gain = G
I_Gain = G*Ki*T/Ti
D_Gain = G*Kd*Td/T
Note: If Ti is zero, I_Gain = 0

Errork      = Target - Feedback
ErrorSumk = ErrorSumk-1 + Errork

Pk = Errork * P_Gain

Ik = ErrorSumk * I_Gain

Dk = (Errork-Errork-1) * D_Gain

PIDOutputk = Pk + Ik + Dk
```

Figure 12 – PID Control Algorithm

Each system will have to be tuned for the optimum output response. Response times, overshoots and other variables will have to be decided by the customer using an appropriate PID tuning strategy.

1.5. Lookup Table Function Block

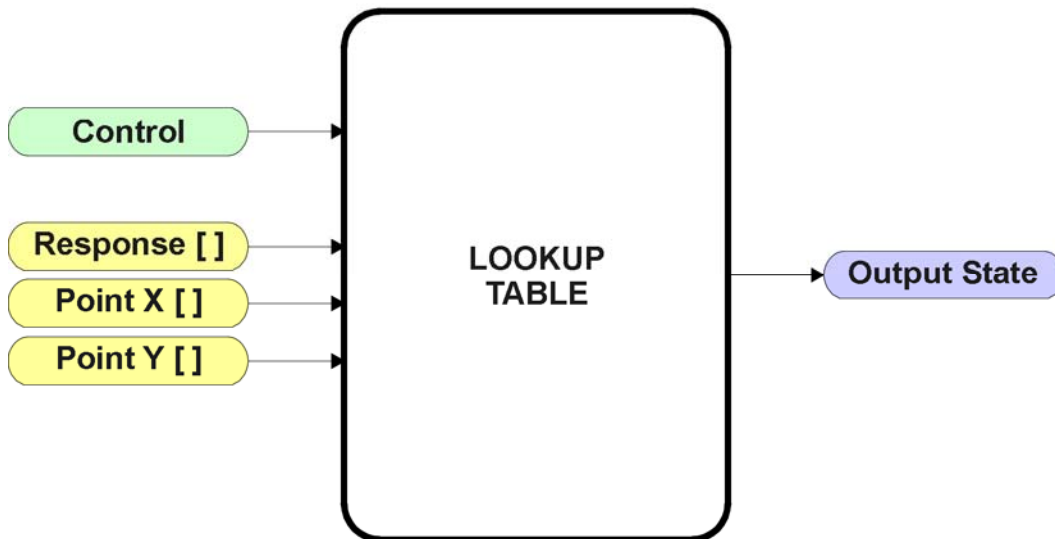



Figure 13 – Lookup Table Function Block

Lookup Tables are used to give an output response of up to 10 slopes per input. The array size of the Response [], Point X [] and Point Y [] setpoints shown in the block diagram above is therefore 11.

Note: If more than 10 slopes are required, a Programmable Logic Block can be used to combine up to three tables to get 30 slopes, as is described in Section 1.6.

There are two key setpoints that will affect this function block. The first is the “**X-Axis Source**” and “**X-Axis Number**” which together define the Control Source for the function block. When it is changed, the table is automatically updated with new defaults based on the X-Axis source selected.

As stated earlier, should the Control Source change (i.e. the Min or Max values of the function block are updated), the table will be automatically updated with default settings, based on the new X-Axis limits.

	Initialize the Control Source of a Lookup Table BEFORE changing the table values, as the new settings WILL get erased when the control is updated!
---	--

The second setpoint that will affect the function block (i.e. reset to defaults), is the “**X-Axis Type**”. By default, the tables have a ‘*Data Response*’ output. Alternatively, it can be selected as a ‘*Time Response*’, which is described later in Section 1.5.5.

1.5.1. X-Axis, Input Data Response

In the case where the **X-Axis Type** = *'Data Response'*, the points on the X-Axis represents the data of the control source.

For example, if the control source is a Universal Input, setup as a 0-5V type, with an operating range of 0.5V to 4.5V, the X-Axis will be setup to have a default **Point 1 – X Value** of 0.5V, and setpoint **Point 10 – X Value** will be set to 4.5V. The **Point 0 – X Value** will be set to the default value of 0.0V.

For most 'Data Responses', the default value at point (0,0) is [0,0].

However, should the minimum input be less than zero, for example a CAN message that is reflecting temperature in the range of -40°C to 210°C, then the **Point 0 – X Value** will be set to the minimum instead, in this case -40°C.

The constraint on the X-Axis data is that the next index value is greater than or equal to the one below it, as shown in the equation below. Therefore, when adjusting the X-Axis data, it is recommended that X₁₀ is changed first, then lower indexes in descending order.

$$\text{MinInputRange} \leq X_0 \leq X_1 \leq X_2 \leq X_3 \leq X_4 \leq X_5 \leq X_6 \leq X_7 \leq X_8 \leq X_9 \leq X_{10} \leq \text{MaxInputRange}$$

As stated earlier, MinInputRange and MaxInputRange will be determined by the X-Axis Source that has been selected.

1.5.2. Y-Axis, Lookup Table Output

By default, it is assumed that the output from the Lookup Table function block will be a percentage value in the range of 0 to 100.

In fact, so long as all the data in the Y-Axis is $0 \leq Y[i] \leq 100$ (where $i = 0$ to 10) then other function blocks using the Lookup Table as a control source will have 0 and 100 as the Xmin and Xmax values used in linear calculations shown in Figure 6.

However, the Y-Axis has no constraints on the data that it represents. This means that inverse, or increasing/decreasing or other responses can be easily established.

For example, should the X-Axis of a table be a resistive value (as read from a Universal Input), the output of the table could be temperature from an NTC sensor in the range $Y_0 = 125^\circ\text{C}$ to $Y_{10} = -20^\circ\text{C}$. If this table is used as the control source for another function block (i.e. transmitted over CAN), then Xmin would be -20 and Xmax would be 125 when used the linear formula.

In all cases, the controller looks at the **entire range** of the data in the Y-Axis setpoints, and selects the lowest value as the MinOutRange and the highest value as the MaxOutRange. So long as they are not both within the 0 to 100 range, they are passed directly to other function blocks as the limits on the Lookup Table output. (i.e used as Xmin and Xmax values in linear calculations.)

Even if some of the data points are *'Ignored'* as described in Section 1.5.4, they are still used in the Y-Axis range determination. If not all the data points are going to be used, it is recommended that Y₉ be set to the minimum end of the range, and Y₁₀ to the maximum first. This way, the user can get predictable results when using the Table to drive another function block, such as an Output Drive.

1.5.3. Default Configuration, Data Response

By default, the first four Lookup Tables, use Inputs 1 to 4 as the X-Axis, and output current (in mA) in the range of the corresponding Output Drives. As these tables are the default **“Control Source”** for Output X Control, where X = 1 to 4, the default response of the Outputs is a linear reaction to change at the inputs. (See Graph A in Figure 14) If a non-linear response for one or more of the outputs is required, the user can easily use the table(s) to create the desired response profiles.

Recall, any controlled function block which uses the Lookup Table as an input source (not only the Output Drive) will also apply a linearization to the data. **Therefore, for a 1:1 control response, ensure that the minimum and maximum values of the output (Ymin and Ymax in Figure 6) correspond to the minimum and maximum values of the table’s Y-Axis (Xmin and Xmax in Figure 6).**

To control “Output N Drive” by “Universal Input N” modified by “Lookup Table N” (N = 1 to 4) it is recommended to do so in the following order:

- a) Change Output Drive **“Output at Minimum Command”** and **“Output at Maximum Command”** to the desired limits.
- b) Configure the desired Control Source (i.e. Universal Input, or CAN Received Message), and set the appropriate limits. (Note: If the Control Source is the Universal Input, the table will automatically be updated with new defaults when the **“Input Sensor Type”**, **“Minimum Range”** or **“Maximum Range”** setpoints are updated)
- c) Change the Lookup Table X **“X-Axis Source”** setpoints. (If applicable)
At this point, the X-Axis limits will match the control source, and the Y-Axis limits will match the Output Drive range, in mA.
- d) Update the X and Y setpoints for the application

Note: Order (b) to (d) holds true for all configuration done using any Lookup Table function block.

All other tables (5 to 16) are disabled by default (no control source selected). However, should an **“X-Axis Source”** be selected, the Y-Axis defaults will be in the range of 0 to 100% as described in the “Y-Axis, Lookup Table Output” section above. X-Axis minimum and maximum defaults will be set as described in the “X-Axis, Data Response” section above.

By default, the X and Y axes data is setup for an equal value between each point from the minimum to maximum in each case.

For example, with a 0.5 to 4.5V input (X-Axis) driving a 0 to 1500mA output (Y-Axis), the default points would be setup as per figure (a) below. However, the 100Ω to 200kΩ input (X-Axis) representing 125°C to -20°C (Y-Axis) would be given defaults as per figure (b) below. In each case, the user would have to adjust the table for the desired response.

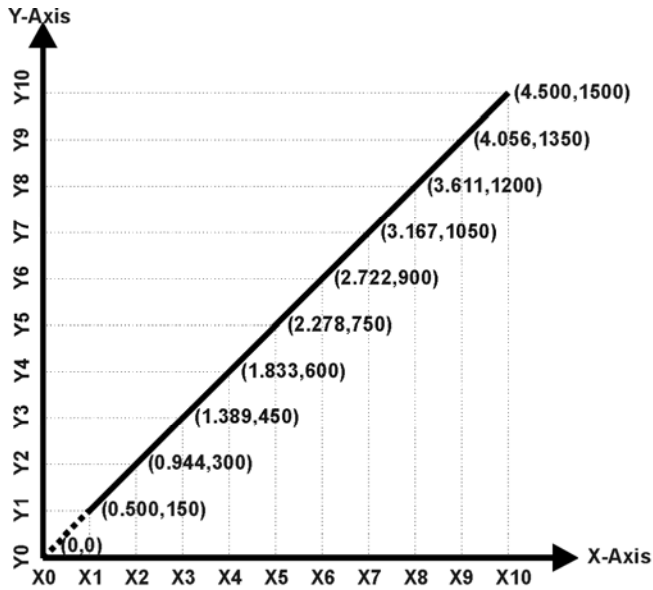

Figure A - 0.5 to 4.5V Input, 0 to 1500mA Output

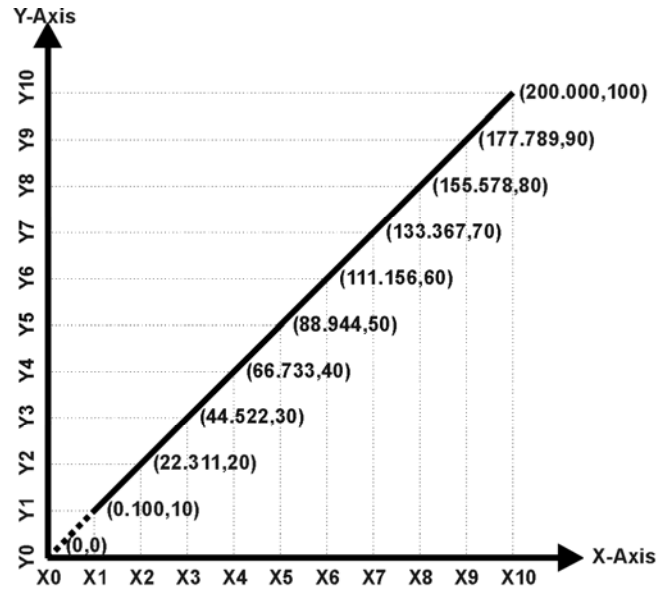

Figure B - 0.1 to 200kOhm Input, 0 to 100% Output

Figure 14 – Lookup Table Default Initialization Examples

1.5.4. Point To Point Response

By default, the X and Y axes are setup for a linear response from point (0,0) to (10,10), where the output will use linearization between each point, as shown in Figure 14. To get the linearization, each **“Point N – Response”**, where N = 1 to 10, is setup for a *‘Ramp To’* output response.

Alternatively, the user could select a *‘Jump To’* response for **“Point N – Response”**, where N = 1 to 10. In this case, any input value between X_{N-1} to X_N will result in an output from the Lookup Table function block of Y_N .

An example of a CAN message (0 to 100) used to control a default table (0 to 100) but with a *‘Jump To’* response instead of the default *‘Ramp To’* is shown in Figure 15.

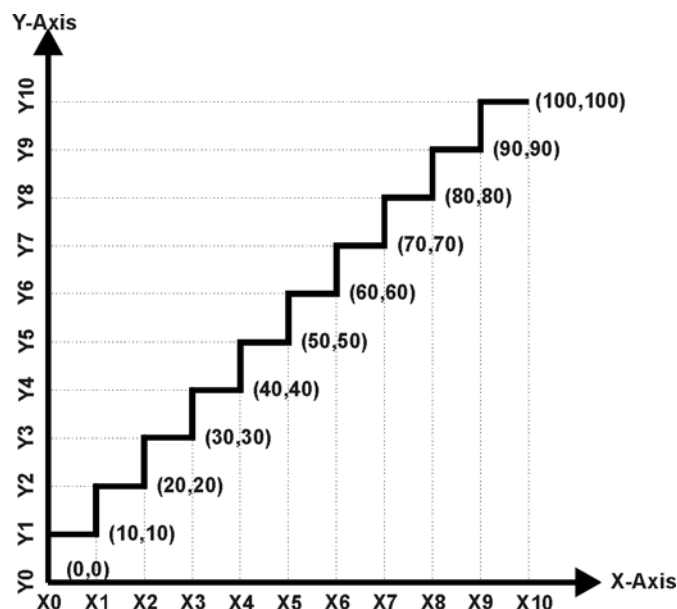

Figure 15 – Lookup Table “Jump To” Data Response

Lastly, any point except (0,0) can be selected for an 'Ignore' response. If "Point N – Response" is set to ignore, then all points from (X_N, Y_N) to (X₁₀, Y₁₀) will also be ignored. For all data greater than X_{N-1}, the output from the Lookup Table function block will be Y_{N-1}.

A combination of 'Ramp To', 'Jump To' and 'Ignore' responses can be used to create an application specific output profile. An example of where the same input (i.e. a CAN Message) is used as the X-Axis for two tables, but where the output profiles 'mirror' each other for a deadband joystick response is shown in Figure 16. The example shows a dual slope output response for each side of the deadband, but additional slopes can be easily added as needed.

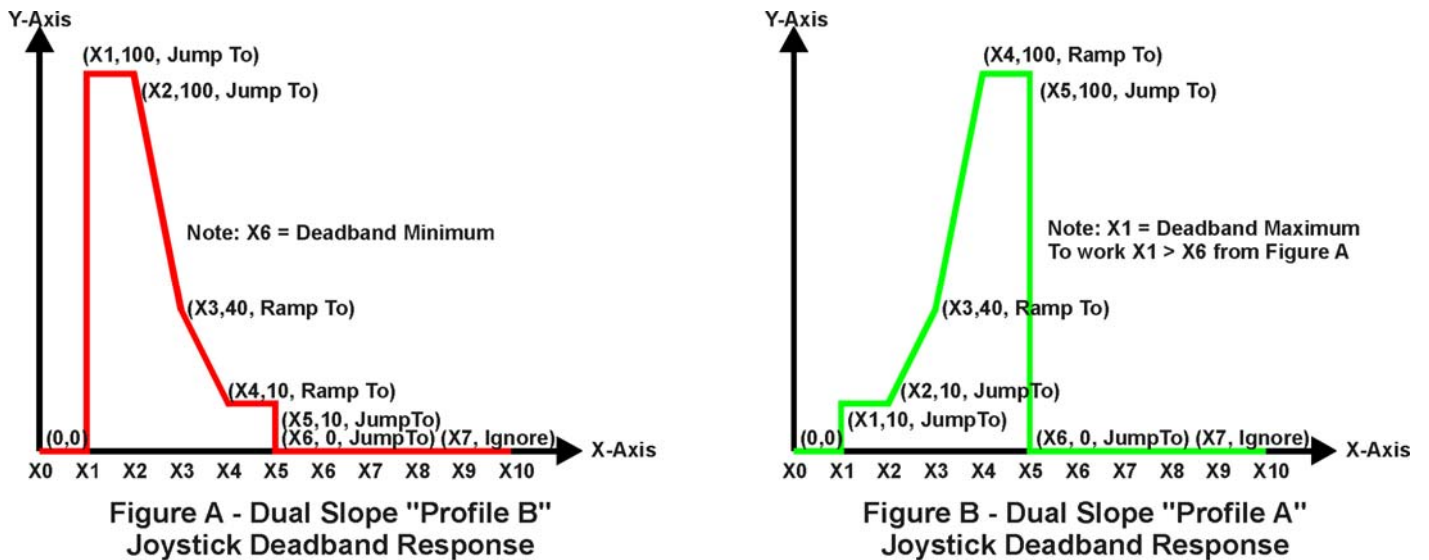

Figure 16 – Lookup Table Examples to Setup for Joystick Deadband Response

1.5.5. X-Axis, Time Response

As mentioned in Section 1.5, a Lookup Table can also be used to get a custom output response where the "X-Axis Type" is a 'Time Response.' When this is selected, the X-Axis now represents time, in units of milliseconds, while the Y-Axis still represents the output of the function block.

In this case, the "X-Axis Source" is treated as a digital input. If the signal is actually an analog input, it is interpreted like a digital input per Figure 10. When the control input is ON, the output will be changed over a period of time based on the profile in the Lookup Table. Once the profile has finished (i.e. index 10, or 'Ignored' response), the output will remain at the last output at the end of the profile until the control input turns OFF.

When the control input is OFF, the output is always at zero. When the input come ON, the profile ALWAYS starts at position (X₀, Y₀) which is 0 output for 0ms.

When using the Lookup Table to drive an output based on **time**, it is mandatory that setpoints "Ramp Up (min to max)" and "Ramp Down (max to min)" in the Output X Drive function block be set to **zero**. Otherwise, the output result will not match the profile as expected. Recall, also, that the Y-Axis range of the table should be set to match the Output Drive range in order to get a 1:1 response of table output versus drive output.

An application where this feature would be useful is filling a clutch when a transmission is engaged. An example of some fill profiles is shown in Figure 17.

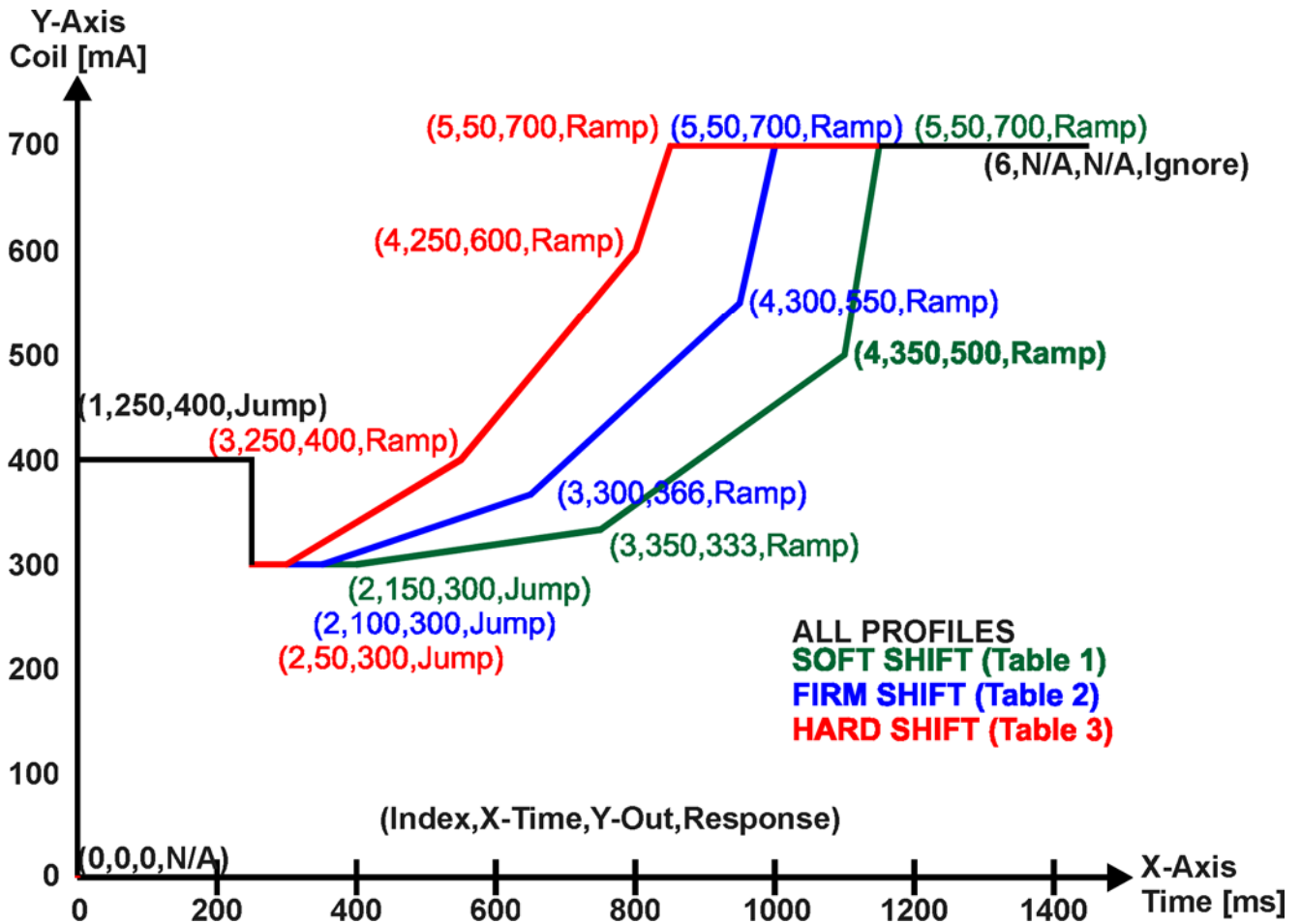

Figure 17 – Lookup Table Time Response Clutch Fill Profiles

In a time response, the interval time between each point on the X-axis can be set anywhere from 1ms to 24 hours. [86,400,000 ms]

One final note about the Lookup Tables is that if a digital input is selected as the control source for the X-Axis, only a 0 (Off) or 1 (On) will be measured. Ensure that the data range for the X-Axis on the table is updated appropriately in this condition.

The screenshot shows the 'Electronic Assistant' software window. The left pane displays a tree view of the configuration for 'J1939 CAN Network' and 'ECU AX021900, 8 Inputs, 5 Outputs #1'. Under 'Setpoint File', 'Lookup Table 6' is selected. The right pane shows a table of setpoint parameters for this configuration.

Setpoint Name	Value	Comment
SP X-Axis Source	4	Received CAN J1939 Message
SP X-Axis Number	1	Received Message 1, Default Output 1 Command
SP X-Axis Type	1	Time Response
SP Point 1 - Response	2	Jump To
SP Point 2 - Response	2	Jump To
SP Point 3 - Response	1	Ramp To
SP Point 4 - Response	1	Ramp To
SP Point 5 - Response	1	Ramp To
SP Point 6 - Response	0	Ignore
SP Point 7 - Response		This point (and higher) is ignored
SP Point 8 - Response		This point (and higher) is ignored
SP Point 9 - Response		This point (and higher) is ignored
SP Point 10 - Response		This point (and higher) is ignored
SP Point 0 - X Value		Parameter not used with this configuration
SP Point 1 - X Value	250.000	ms
SP Point 2 - X Value	150.000	ms
SP Point 3 - X Value	350.000	ms
SP Point 4 - X Value	350.000	ms
SP Point 5 - X Value	50.000	ms
SP Point 6 - X Value		This point (and higher) is ignored
SP Point 7 - X Value		This point (and higher) is ignored
SP Point 8 - X Value		This point (and higher) is ignored
SP Point 9 - X Value		This point (and higher) is ignored
SP Point 10 - X Value		This point (and higher) is ignored
SP Point 0 - Y Value		Parameter not used with this configuration
SP Point 1 - Y Value	400.000	
SP Point 2 - Y Value	300.000	
SP Point 3 - Y Value	333.000	
SP Point 4 - Y Value	500.000	
SP Point 5 - Y Value	700.000	
SP Point 6 - Y Value		This point (and higher) is ignored
SP Point 7 - Y Value		This point (and higher) is ignored
SP Point 8 - Y Value		This point (and higher) is ignored
SP Point 9 - Y Value		This point (and higher) is ignored
SP Point 10 - Y Value		This point (and higher) is ignored

Figure 18 – Lookup Table “Soft Shift” EA Configuration

1.6. Programmable Logic Function Block

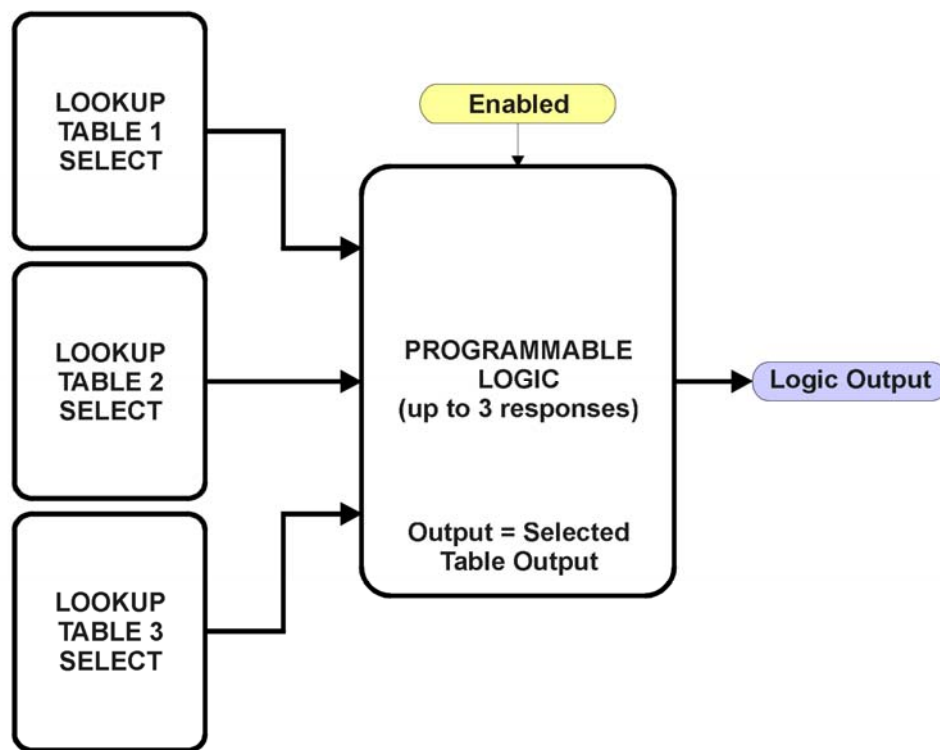
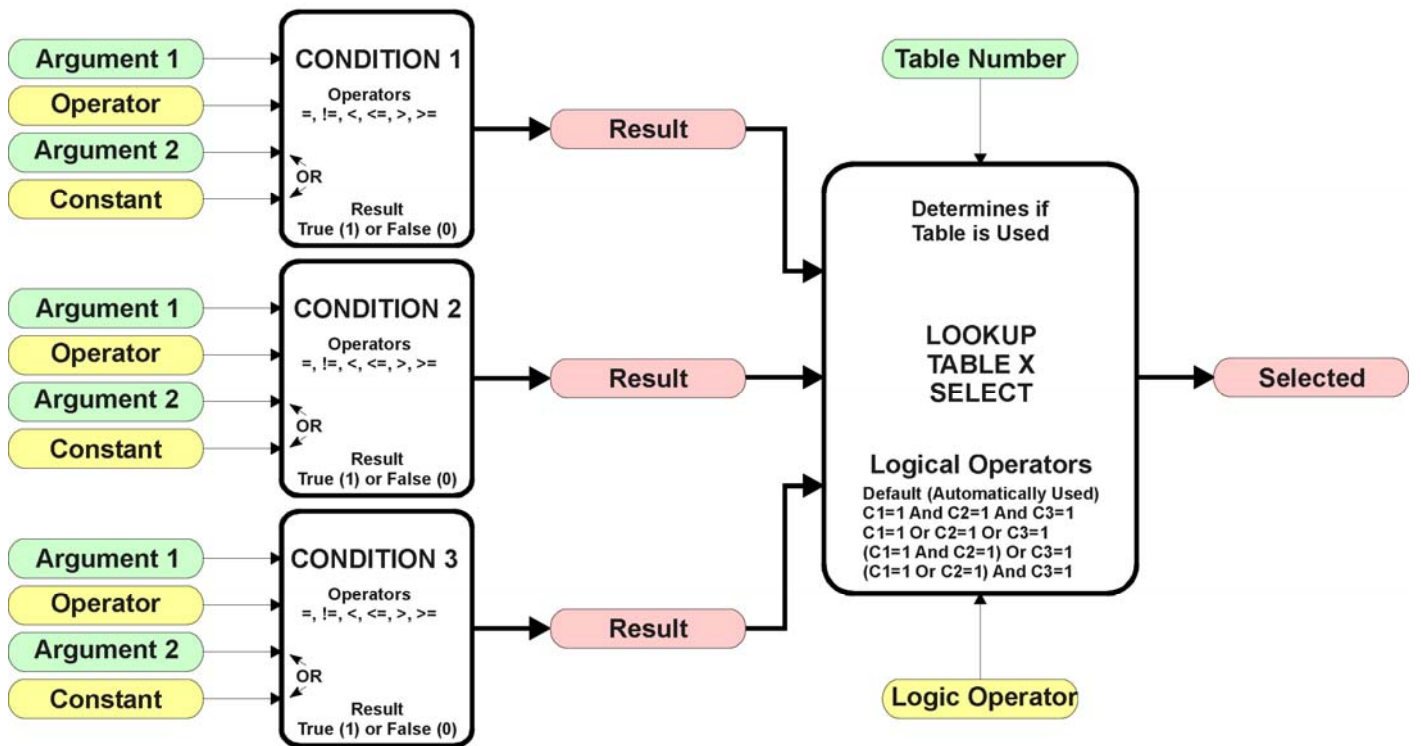

Figure 19 – Programmable Logic Function Block

This function block is obviously the most complicated of them all, but very powerful. The Programmable Logic can be linked to up to three tables, any one of which would be selected only under given conditions. Any three tables (of the available 16) can be associated with the logic, and which ones are used is fully configurable.

Should the conditions be such that a particular table (1, 2 or 3) has been selected as described in Section 1.6.2, then the output from the selected table, at any given time, will be passed directly to the Logic Output.

Therefore, up to three different responses to the same input, or three different responses to different inputs, can become the input to another function block, such as an Output X Drive. To do this, the “**Control Source**” for the reactive block would be selected to be the *‘Programmable Logic Function Block.’*

In order to enable any one of Programmable Logic blocks, the “**Programmable Logic Block Enabled**” setpoint must be set to True. They are all disabled by default.

Logic is evaluated in the order shown in Figure 20. Only if a lower number table has not been selected will the conditions for the next table be looked at. **The default table is always selected as soon as it is evaluated. It is therefore required that the default table always be the highest number in any configuration.**

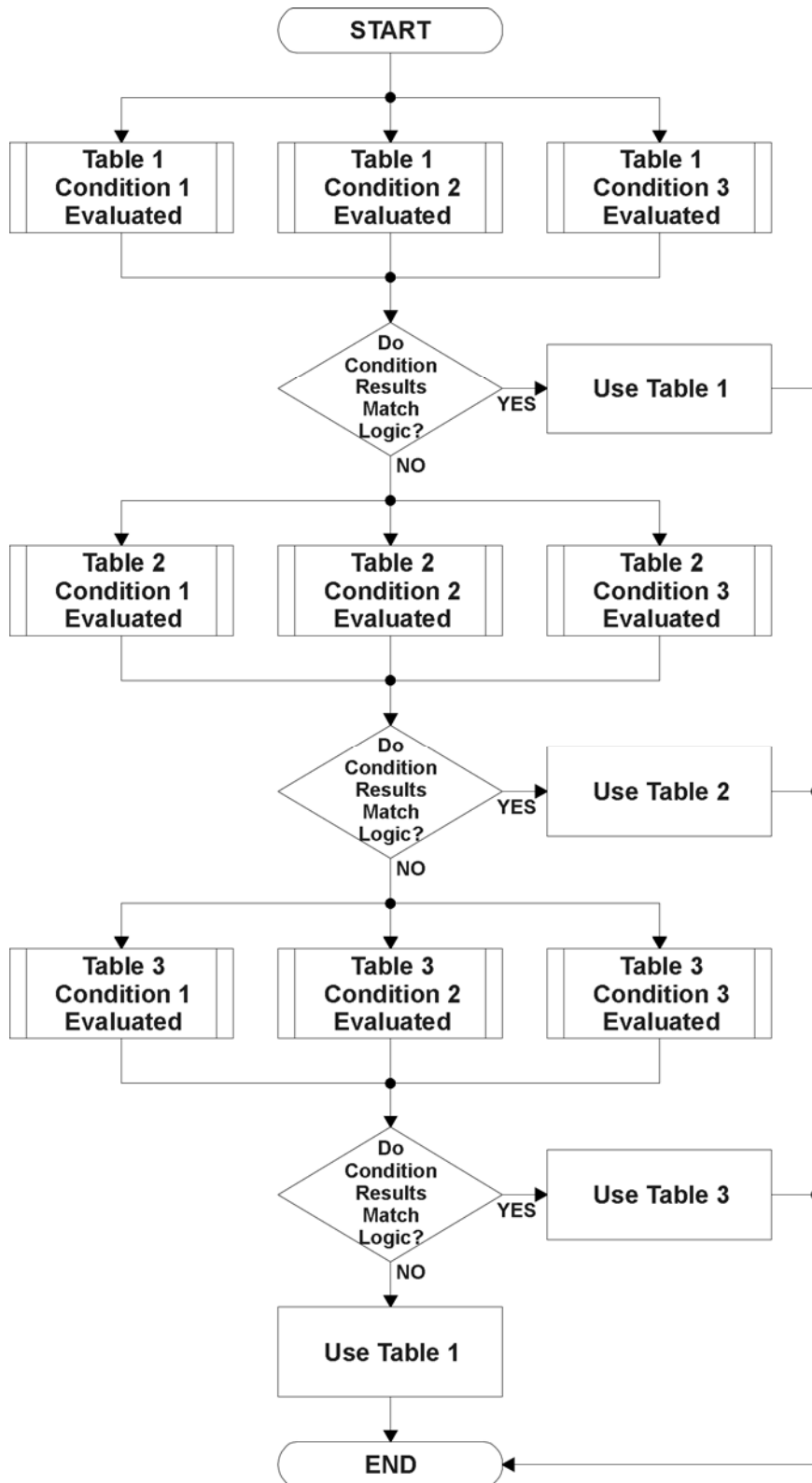

Figure 20 – Programmable Logic Flowchart

1.6.1. Conditions Evaluation

The first step in determining which table will be selected as the active table is to first evaluate the conditions associated with a given table. Each table has associated with it up to three conditions that can be evaluated.

Argument 1 is always a logical output from another function block, as listed in Section 1.14. As always, the source is a combination of the functional block type and number, setpoints “**Table X, Condition Y, Argument 1 Source**” and “**Table X, Condition Y, Argument 1 Number**”, where both X = 1 to 3 and Y = 1 to 3.

Argument 2 on the other hand, could either be another logical output such as with Argument 1, OR a constant value set by the user. To use a constant as the second argument in the operation, set “**Table X, Condition Y, Argument 2 Source**” to ‘*Control Constant (Logic Argument 2 Only)*.’ This will automatically enable “**Table X, Condition Y, Argument 2 Value**” instead of the “... **Number**” setpoint. The constant value has no unit associated with it in EA, so the user must set it as needed for the application.

The condition is evaluated based on the “**Table X, Condition Y Operator**” selected by the user. It is always ‘=, Equal’ by default. The only way to change this is to have two valid arguments selected for any given condition. Options for the operator are listed in Table 13

0	=, Equal
1	!=, Not Equal
2	>, Greater Than
3	>=, Greater Than or Equal
4	<, Less Than
5	<=, Less Than or Equal

Table 13 – Condition Operator Options

For example, a condition for a transmission control shift selection, as shown in Figure 17 in the previous section, could be that the Engine RPM be less than a certain value to select a Soft Fill profile. In this case, “...**Argument 1 Source**” would be set to ‘*Magnetic Pickup Frequency/RPM*’, “...**Argument 2 Source**” to ‘*Control Constant (Logic Argument 2 Only)*’, and the “...**Operator**” to ‘<, Less Than.’ The “...**Argument 2 Value**” would be set to whatever cutoff RPM the application required.

By default, both arguments are set to ‘Control Source Not Used’ which disables the condition, and automatically results in a value of N/A as the result. Although Figure 19 shows only True or False as a result of a condition evaluation, the reality is that there could be four possible results, as described in Table 14.

Value	Meaning	Reason
0	False	(Argument 1) Operator (Argument 2) = False
1	True	(Argument 1) Operator (Argument 2) = True
2	Error	Argument 1 or 2 output was reported as being in an error state
3	Not Applicable	Argument 1 or 2 is not available (i.e. set to ‘Control Source Not Used’)

Table 14 – Condition Evaluation Results

1.6.2. Table Selection

In order to determine if a particular table will be selected, logical operations are performed on the results of the conditions as determined by the logic in Section 1.6.1. There are several logical combinations that can be selected, as listed in Table 15.

0	<i>Default Table</i>
1	<i>Cnd1 And Cnd2 And Cnd3</i>
2	<i>Cnd1 Or Cnd2 Or Cnd3</i>
3	<i>(Cnd1 And Cnd2) Or Cnd3</i>
4	<i>(Cnd1 Or Cnd2) And Cnd3</i>

Table 15 – Conditions Logical Operator Options

Not every evaluation is going to need all three conditions. The case given in the earlier section, for example, only has one condition listed, i.e. that the Engine RPM be below a certain value. Therefore, it is important to understand how the logical operators would evaluate an Error or N/A result for a condition.

Logical Operator	Select Conditions Criteria
Default Table	Associated table is automatically selected as soon as it is evaluated.
Cnd1 And Cnd2 And Cnd3	<p>Should be used when two or three conditions are relevant, and all must be true to select the table.</p> <p>If any condition equals False or Error, the table is not selected. An N/A is treated like a True. If all three conditions are True (or N/A), the table is selected.</p> <p>If((Cnd1==True) &&(Cnd2==True)&&(Cnd3==True)) Then Use Table</p>
Cnd1 Or Cnd2 Or Cnd3	<p>Should be used when only one condition is relevant. Can also be used with two or three relevant conditions.</p> <p>If any condition is evaluated as True, the table is selected. Error or N/A results are treated as False</p> <p>If((Cnd1==True) (Cnd2==True) (Cnd3==True)) Then Use Table</p>
(Cnd1 And Cnd2) Or Cnd3	<p>To be used only when all three conditions are relevant.</p> <p>If both Condition 1 and Condition 2 are True, OR Condition 3 is True, the table is selected. Error or N/A results are treated as False</p> <p>If(((Cnd1==True)&&(Cnd2==True)) (Cnd3==True)) Then Use Table</p>
(Cnd1 Or Cnd2) And Cnd3	<p>To be used only when all three conditions are relevant.</p> <p>If Condition 1 And Condition 3 are True, OR Condition 2 And Condition 3 are True, the table is selected. Error or N/A results are treated as False</p> <p>If(((Cnd1==True) ((Cnd2==True)) && (Cnd3==True)) Then Use Table</p>

Table 16 – Conditions Evaluation Based on Selected Logical Operator

The default “**Table X, Conditions Logical Operator**” for Table 1 and Table 2 is ‘*Cnd1 And Cnd2 And Cnd3,*’ while Table 3 is set to be the ‘*Default Table.*’

1.6.3. Logic Block Output

Recall that Table X, where X = 1 to 3 in the Programmable Logic function block does NOT mean Lookup Table 1 to 3. Each table has a setpoint “**Table X – Lookup Table Block Number**” which allows the user to select which Lookup Tables they want associated with a particular Programmable Logic Block. The default tables associated with each logic block are listed in Table 17.

Programmable Logic Block Number	Table 1 – Lookup Table Block Number	Table 2 – Lookup Table Block Number	Table 3 – Lookup Table Block Number
1	5	6	7
2	8	9	10
3	11	12	13
4	14	15	16

Table 17 – Programmable Logic Block Default Lookup Tables

If the associated Lookup Table does not have an “**X-Axis Source**” selected, then the output of the Programmable Logic block will always be “Not Available” so long as that table is selected. However, should the Lookup Table be configured for a valid response to an input, be it Data or Time, the output of the Lookup Table function block (i.e. the Y-Axis data that has been selected based on the X-Axis value) will become the output of the Programmable Logic function block so long as that table is selected.

Unlike all other function blocks, the Programmable Logic does NOT perform any linearization calculations between the input and the output data. Instead, it mirrors exactly the input (Lookup Table) data. Therefore, when using the Programmable Logic as a control source for another function block, it is HIGHLY recommended that all the associated Lookup Table Y-Axes either be (a) Set between the 0 to 100% output range or (b) all set to the same scale.

1.6.4. Application Ideas

This section is not meant to be a comprehensive list of all the possibilities that the Programmable Logic offers. Rather, it is meant to show how some common, but widely diversified functions can be achieved by using it.

- a) Dual Speed Application – Under certain conditions, a valve could be driven between Min_A to Max_A while under others, the speed is limited by having the output respond to changes at the input between Min_B and Max_B.
- b) Multi-Speed Transmission Control – By using a Forward input as the enable of one Output X Drive, and the Reverse input as the other, different clutch fill profiles could be selected based on Engine Speed as discussed in earlier examples.
- c) Getting better resolution (i.e. up to 30 slopes) on a resistive to temperature curve for an NTC sensor. The condition for Table 1 would be input resistance $\leq R1$, Table 2 is input $\leq R2$ and Table 3 as the default for high resistance values.

1.7. Math Function Block

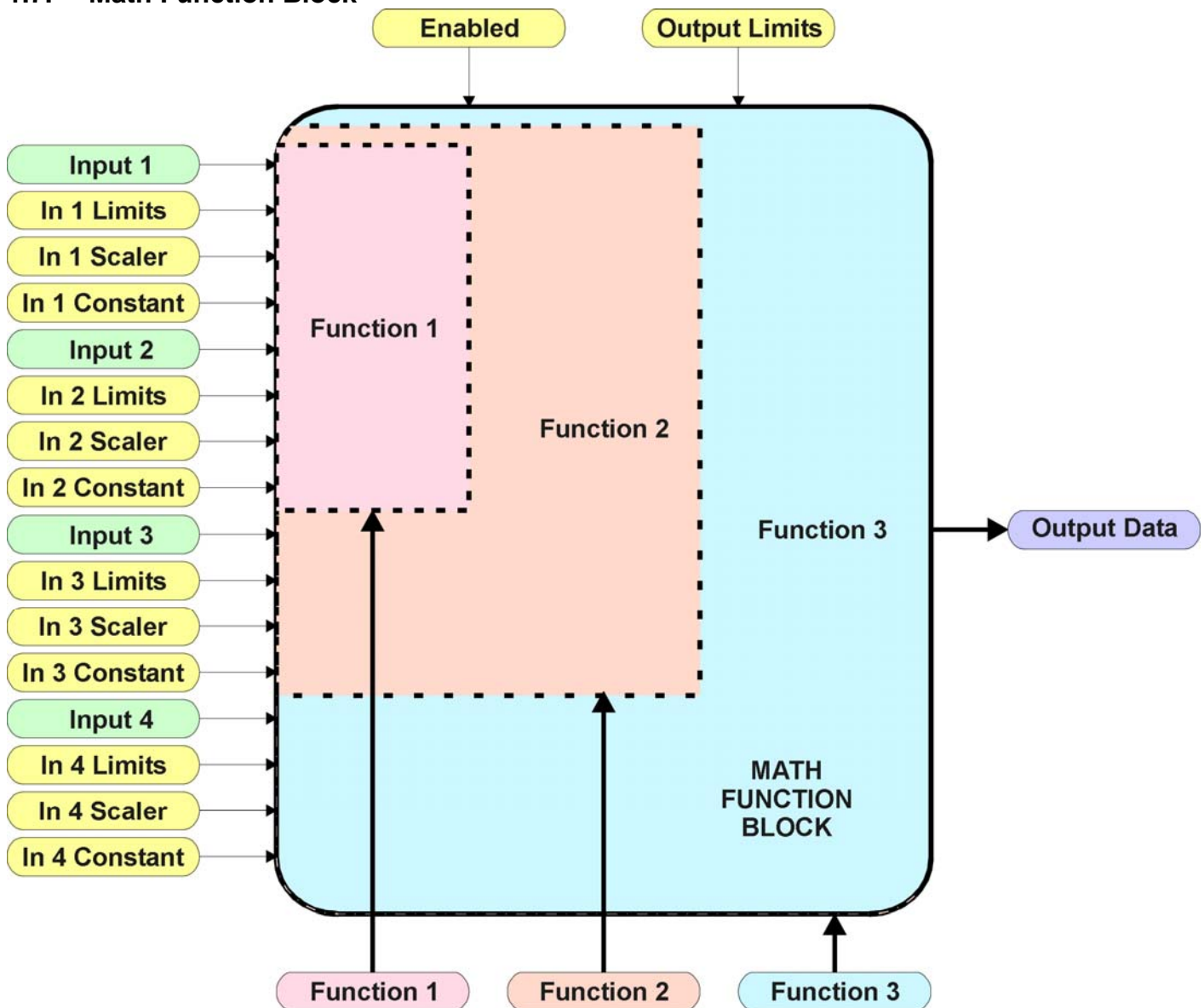

Figure 21 – Math Function Block

There are three mathematics function blocks that allow the user to define basic algorithms. A math function block can take up to four input signals, as listed in Table 25 in Section 1.13. Each input is then scaled according to the associated limit and scaling setpoints.

Inputs are converted into a percentage value based on the “**Math Input X Minimum**” and “**Math Input X Maximum**” values selected, where $X = 1$ to 4 . For additional control, the user can also adjust the “**Math Input X Scaler**.” By default, each input has a scaling ‘weight’ of 1.0. However, each input can be scaled from -1.0 to 1.0 as necessary before it is applied in the function.

For example, in the case where the user may want to combine two inputs such that a joystick (Input 1) is the primary control of an output, but the speed can be incremented or decremented based on a potentiometer (Input 2), it may be desired that 75% of the scale is controlled by the joystick position, while the potentiometer can increase or decrease the min/max output by up to 25%. In this case, Input 1 would be scaled with 0.75, while Input 2 uses 0.25. The resulting addition will give a command from 0 to 100% based on the combined positions of both inputs.

The appropriate arithmetic or logical operation is performed on the two inputs, InA and InB, according to the associated function. The list of selectable function operations is defined in Table 18.

0	=	True when InA Equals InB
1	!=	True when InA Not Equal InB
2	>	True when InA Greater Than InB
3	>=	True when InA Greater Than or Equal InB
4	<	True when InA Less Than InB
5	<=	True when InA Less Than or Equal InB
6	OR	True when InA or InB is True
7	AND	True when InA and InB are True
8	XOR	True when InA/InB is True, but not both
9	+	Result = InA plus InB
10	-	Result = InA minus InB
11	x	Result = InA times InB
12	/	Result = InA divided by InB
13	MIN	Result = Smallest of InA and InB
14	MAX	Result = Largest of InA and InB

Table 18 – Math Function Operators

For Function 1, InA and InB are Inputs 1 and 2 respectively.

For Function 2, InA is the result of Function 1, and InB is Input 3.

For Function 3, InA is the result of Function 2, and InB is Input 4.

For a valid result, the control source for an input must be a non-zero value, i.e. something other than ‘Control Source Not Used.’ Otherwise, the corresponding function is ignored, and the “Output Data” for the math function block is the result of the earlier function scaled according to the output limit setpoints. For example, if Input 4 is not used, the math output would be the result of the Function 2 operation.

For logical operators (6, 7 or 8), any SCALED input greater than or equal to 0.5 is treated as a TRUE input. For logic output operators (0 to 8), the result of the calculation for the function will always be 0 (FALSE) or 1 (TRUE).

Error data (i.e. input measured out of range) is always treated as a 0.0 input into the function.

For the arithmetic functions (9 to 14), it is recommended to scale the data such that the resulting operation will not exceed full scale (0 to 100%) and saturate the output result.

When dividing, a zero InB value will always result in a zero output value for the associated function. When subtracting, a negative result will always be treated as a zero, unless the function is multiplied by a negative one, or the inputs are scaled with a negative coefficient first.

The resulting mathematical calculation, represented as a percentage value, can be scaled into the appropriate physical units using the “**Math Output Minimum Range**” and “**Math Output Maximum Range**” setpoints. These values are also used as the limits when the Math Function is selected as the input source for another function block.

1.8. Filtering Function Block

The filtering function block is associated with the universal input and the proportional output drive function blocks.

When used with an input, the software filter is applied to the measured signal (from 12-bit analog-to-digital converter in the case of a voltage/current/resistive input, or from the 15-bit timer in the case of a frequency/PWM input) before the value is moved to the output of the function block, and used as an input to other function blocks (i.e. control or feedback input)

When used with an output, the software filter is applied to the measured current feedback value of the drive before it is used for error detection and as a feedback signal input to other function blocks (i.e. CAN transmission)

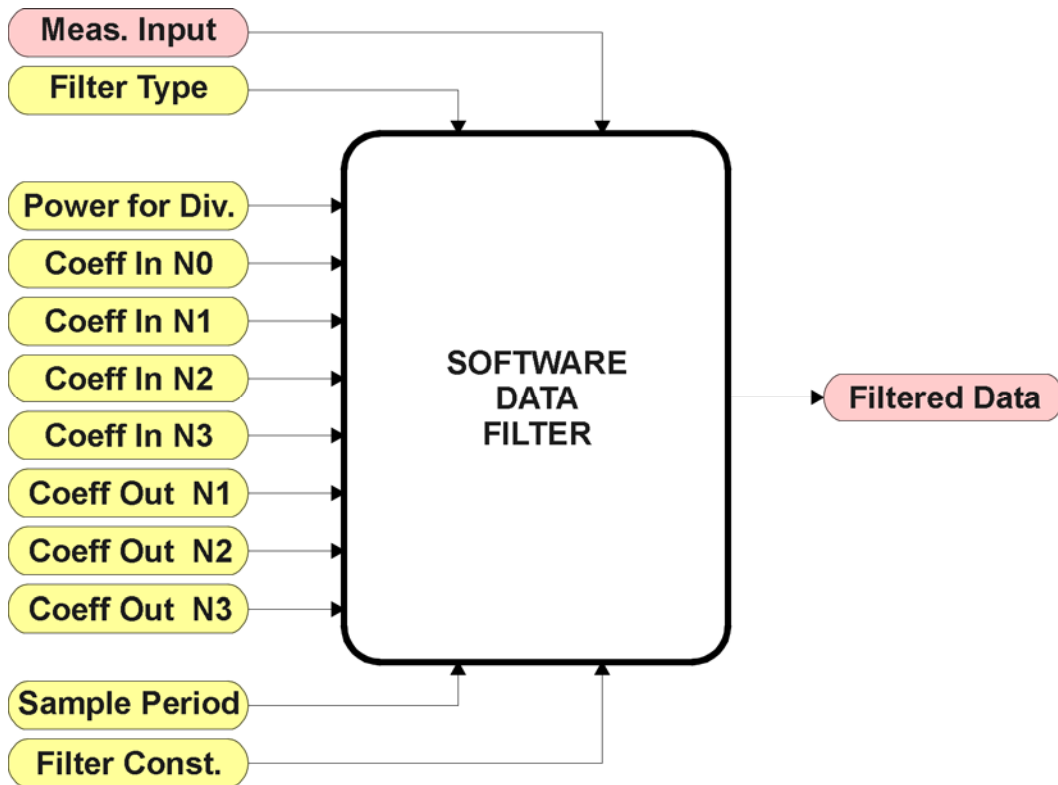

Figure 22 – Software Data Filter Function Block

The “**Software Filter Type**” is the most important setpoint associated with this function block, and it should be selected first. Changing it will result in other setpoints being enabled/disabled as appropriate for the selected filter. The available filters type are shown in Table 19.

0	<i>No Filter</i>
1	<i>Moving Average</i>
2	<i>Repeating Average</i>
3	<i>3rd Order Low Pass</i>

Table 19 – Software Filter Types

Calculation with no filter:

Value = Input

The data is simply a ‘snapshot’ of the latest value measured by the ADC or timer.

Calculation with the moving average filter:

$$\text{Value}_N = \text{Value}_{N-1} + \frac{(\text{Input} - \text{Value}_{N-1})}{\text{FilterConstant}}$$

This filter is called every 1ms.

Calculation with the repeating average filter:

$$\text{Value} = \frac{\sum \text{Input}_N}{N}$$

At every reading of the input value, it is added to the sum. At every Nth read, the sum is divided by N, and the result is the new input value. The value and counter will be set to zero for the next read. The value of N is stored in the “**Filter Constant**” setpoint. This filter is called every 1ms.

Calculation with the 3rd Order Low Pass filter:

$$\text{Value}_N = \frac{[C_{IN0} * \text{Input}_N + C_{IN1} * \text{Input}_{N-1} + C_{IN2} * \text{Input}_{N-2} + C_{IN3} * \text{Input}_{N-3} + C_{OUT1} * \text{Value}_{N-1} + C_{OUT2} * \text{Value}_{N-2} + C_{OUT3} * \text{Value}_{N-3}]}{2^{\text{Power}}}$$

C_{IN0} Coefficient for Input(n)

C_{IN1} Coefficient for Input(n-1)

C_{IN2} Coefficient for Input(n-2)

C_{IN3} Coefficient for Input(n-3)

C_{OUT1} Coefficient for Output(n-1)

C_{OUT2} Coefficient for Output(n-2)

C_{OUT3} Coefficient for Output(n-3)

This filter uses 16-bit fixed point math. The “**Filter Power for Divisor**” setpoint tells the controller the shift value used when the coefficients were selected.

The filter will be called every “**Filter Sampling Period**” (in ms). In between calls, the data of the input/feedback signal is the value which was calculated the last time the filter was called.

1.9. Diagnostic Function Block

There are several types of diagnostics supported by the 8i5o Valve Controller. Fault detection and reaction is associated with all universal inputs and output drives. In addition to I/O faults, the 8i5o can also detect/react to power supply or lost communication events.

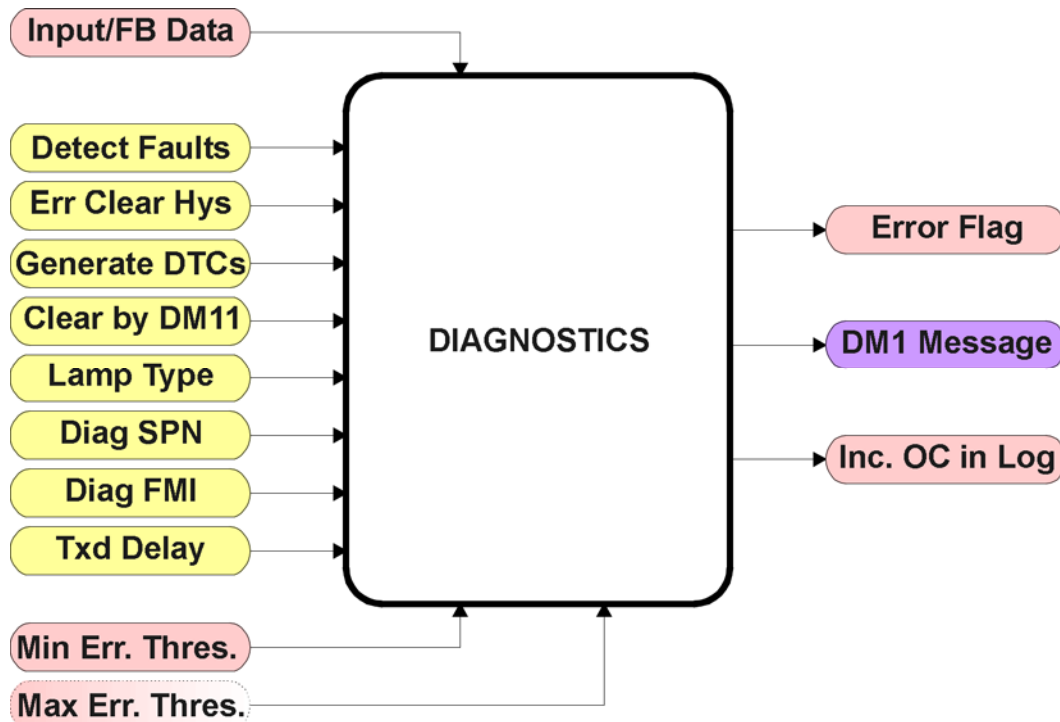

Figure 23 – Diagnostics Function Block

The “**Fault Detection is Enabled**” is the most important setpoint associated with this function block, and it should be selected first. Changing it will result in other setpoints being enabled/disabled as appropriate. When disabled, all diagnostic behaviour associated with the I/O or event in question is ignored (i.e. this type of fault will not disable the output)

In the case of a power supply error, it can be selected to disable the 2.5A proportional outputs. By default, a power supply under or over voltage condition will not shutoff the outputs.

In most cases, faults can be flagged as either a low or high occurrence. The min/max thresholds for all diagnostics supported by the 8i5o are listed in Table 20. Bolded values are user configurable setpoints. Some diagnostics react only to a single condition, in which case a N/A is listed in one of the columns.

Function Block	Minimum Threshold	Maximum Threshold
Universal Input	Minimum Error	Maximum Error
Output Drive	50mA (when ON)	2750 mA (Software) *
Digital Output	N/A	Feedback Signal Fault (Hardware)
Power Supply	Power Undervoltage Threshold	Power Overvoltage Threshold
Lost Communication	N/A	Received Message Timeout (any)

Table 20 – Fault Detect Thresholds

* *The proportional output current drives also have a hardware shutdown in the case of a dead short to GND. In this condition, the diagnostic FMI sent to the CAN network will likely be 5, the “Current Below Normal or Open Circuit” value because the processor is reading a ~0mA feedback when it tries to drive the output .*

When applicable, a hysteresis setpoint is provided to prevent the rapid setting and clearing of the error flag when an input or feedback value is right near the fault detection threshold. For the low end, once a fault has been flagged, it will not be cleared until the measured value is greater than or equal to the Minimum Threshold + **“Hysteresis to Clear Fault.”** For the high end, it will not be cleared until the measured value is less than or equal to the Maximum Threshold - **“Hysteresis to Clear Fault.”** The minimum, maximum and hysteresis values are always measured in the units of the fault in question.

The next setpoint in this function block is the **“Event Generates a DTC in DM1.”** If and only if this is set to true will the other setpoints in the function block be enabled. They are all related to the data that is sent to the J1939 network as part of the DM1 message, Active Diagnostic Trouble Codes.

A Diagnostic Trouble Code (DTC) is defined by the J1939 standard as a four byte value which is a combination of:

SPN	Suspect Parameter Number	(first 19 bits of the DTC, LSB first)
FMI	Failure Mode Identifier	(next 5 bits of the DTC)
CM	Conversion Method	(1 bit, always set to 0)
OC	Occurrence Count	(7 bits, number of times the fault has happened)

In addition to supporting the DM1 message, the 8i50 Valve Controller also supports

DM2	Previously Active Diagnostic Trouble Codes	Sent only on request
DM3	Diagnostic Data Clear/Reset of Previously Active DTCs	Done only on request
DM11	Diagnostic Data Clear/Reset for Active DTCs	Done only on request

So long as even one Diagnostic function block has **“Event Generates a DTC in DM1”** set to True, the 8i50 Valve Controller will send the DM1 message every one second, regardless of whether or not there are any active faults, as recommended by the standard. While there are no active DTCs, the 8i50 will send the “No Active Faults” message. If a previously inactive DTC becomes active, a DM1 will be sent immediately to reflect this. As soon as the last active DTC goes inactive, it will send a DM1 indicating that there are no more active DTCs.

If there is more than one active DTC at any given time, the regular DM1 message will be sent using a multipacket Broadcast Announce Message (BAM). If the controller receives a request for a DM1 while this is true, it will send the multipacket message to the Requester Address using the Transport Protocol (TP).



At power up, the DM1 message will not be broadcasted until after a 10 second delay. This is done to prevent any power up or initialization conditions from being flagged as an active error on the network.

When the fault is linked to a DTC, a non-volatile log of the occurrence count (OC) is kept. As soon as the controller detects a new (previously inactive) fault, it will start decrementing the “**Delay Before Sending DM1**” timer for that Diagnostic function block. If the fault has remained present during the delay time, then the controller will set the DTC to active, and will increment the OC in the log. A DM1 will immediately be generated that includes the new DTC. The timer is provided so that intermittent faults do not overwhelm the network as the fault comes and goes, since a DM1 message would be sent every time the fault shows up or goes away.

Previously active DTCs (any with a non-zero OC) are available upon request for a **DM2** message. If there is more than one previously active DTC, the multipacket DM2 will be sent to the Requester Address using the Transport Protocol (TP).

Should a **DM3** be requested, the occurrence count of all previously active DTCs will be reset to zero. The OC of currently active DTCs will not be changed.

The Diagnostic function block has a setpoint “**Event Cleared only by DM11.**” By default, this is always set to False, which means that as soon as the condition that caused an error flag to be set goes away, the DTC is automatically made Previously Active, and is no longer included in the DM1 message. However, when this setpoint is set to True, even if the flag is cleared, the DTC will not be made inactive, so it will continue to be sent on the DM1 message. Only when a DM11 has been requested will the DTC go inactive. This feature may be useful in a system where a critical fault needs to be clearly identified as having happened, even if the conditions that caused it went away.

In addition to all the active DTCs, another part of the DM1 message is the first byte which reflects the Lamp Status. Each Diagnostic function block has the setpoint “**Lamp Set by Event in DM1**” which determines which lamp will be set in this byte while the DTC is active. The J1939 standard defines the lamps as ‘*Malfunction*’, ‘*Red, Stop*’, ‘*Amber, Warning*’ or ‘*Protect*’. By default, the ‘*Amber, Warning*’ lamp is typically the one set by any active fault.

By default, every Diagnostic function block has associated with it a proprietary SPN. However, this setpoint “**SPN for Event used in DTC**” is fully configurable by the user should they wish it to reflect a standard SPN define in J1939-71 instead. If the SPN is changed, the OC of the associate error log is automatically reset to zero.

Every Diagnostic function block also has associated with it a default FMI. The only setpoint for the user to change the FMI is “**FMI for Event used in DTC,**” even though some Diagnostic function blocks can have both high and low errors as shown in Table 21. In those cases, the FMI in the setpoint reflect that of the low end condition, and the FMI used by the high fault will be determined per Table 19. If the FMI is changed, the OC of the associate error log is automatically reset to zero.

FMI for Event used in DTC – Low Fault	Corresponding FMI used in DTC – High Fault
FMI=1, Data Valid But Below Normal Operational Range - Most Severe Level	FMI=0, Data Valid But Above Normal Operational Range - Most Severe Level
FMI=4, Voltage Below Normal, Or Shorted To Low Source	FMI=3, Voltage Above Normal, Or Shorted To High Source
FMI=5, Current Below Normal Or Open Circuit	FMI=6, Current Above Normal Or Grounded Circuit
FMI=17, Data Valid But Below Normal Operating Range - Least Severe Level	FMI=15, Data Valid But Above Normal Operating Range - Least Severe Level
FMI=18, Data Valid But Below Normal Operating Range - Moderately Severe Level	FMI=16, Data Valid But Above Normal Operating Range - Moderately Severe Level
FMI=21, Data Drifted Low	FMI=20, Data Drifted High

Table 21 – Low Fault FMI versus High Fault FMI



If the FMI used is anything other than one of those in Table 21, then both the low and high faults will be assigned the same FMI. This condition should be avoided, as the log will still used different OC for the two types of faults, even though they will be reported the same in the DTC. It is the user’s responsibility to make sure this does not happen.

1.10. DTC React Function Block

The DTC React function block is a very simple function which will allow a received DTC, sent from another ECU on a DM1 message, to disable an output. Up to five SPN/FMI combinations can be selected.

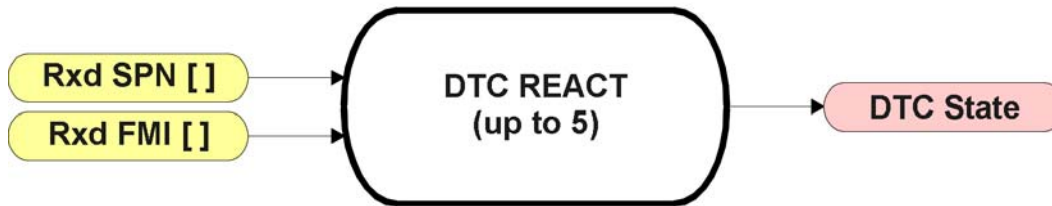

Figure 24 – DTC React Function Block

Should a DM1 message be received with the SPN/FMI combination defined, the corresponding DTC State will be set to ON. Once ON, if the same SPN/FMI combination has not been received again after 3 seconds, the DTC State will be reset to OFF.

The DTC could be used as a digital input for any function block as appropriate.

1.11. CAN Transmit Function Block

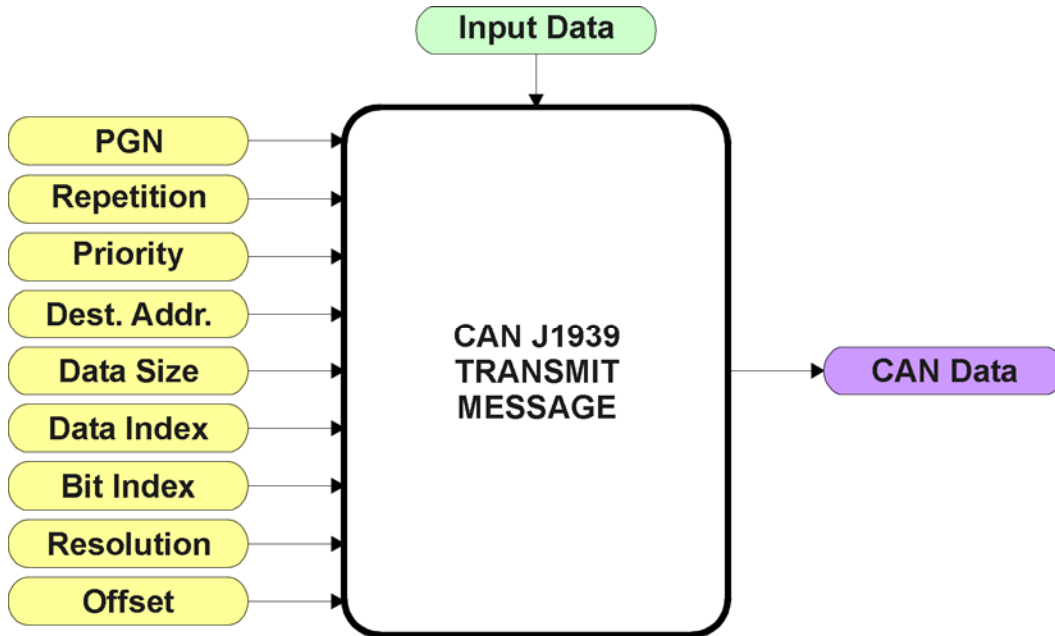

Figure 25 – CAN Transmit Function Block

The CAN Transmit function block is used to send any output from another function block (i.e. input, status or feedback signals) to the J1939 network.

Normally, to disable a transmit message, the “**Transmit Repetition Rate**” is set to zero. However, should message share a its Parameter Group Number (PGN) with another message, this is not necessarily true. In the case where multiple message share the same “**Transmit PGN**”, the repetition rate selected in the message with the **LOWEST** number will be used for **ALL** the messages that use that PGN.

By default, all messages are sent on Proprietary B PGNs as broadcast messages. The default settings do ‘bundle’ multiple messages onto a PGN, as outlined in Section 3. If all of the data is not necessary, disable the entire message by setting the lowest channel using that PGN to zero. If some of the data is not necessary, simply change the PGN of the superfluous channel(s) to an unused value in the Proprietary B range.



At power up, transmitted message will not be broadcasted until after a 3 second delay. This is done to prevent any power up or initialization conditions from creating problems on the network.

Since the defaults are PropB messages, the “**Transmit Message Priority**” is always initialized to 6 (low priority) and the “**Destination Address (for PDU1)**” setpoint is not used. This setpoint is only valid when a PDU1 PGN has been select, and it can be set either to the Global Address (0xFF) for broadcasts, or sent to a specific address as setup by the user.

The “**Transmit Data Size**”, “**Transmit Data Index in Array (LSB)**”, “**Transmit Bit Index in Byte (LSB)**”, “**Transmit Resolution**” and “**Transmit Offset**” can all be use to map the data to any SPN supported by the J1939 standard. The defaults used by the 8i50 are all for proprietary SPNs, and are defined in detail in Section 3.3.

Note: CAN Data = (Input Data – Offset)/Resolution

The 8i50 Valve Controller supports up to 20 unique CAN Transmit Messages, all of which can be programmed to send any available data to the CAN network. By default, each message is pre-configured to send a particular type of data. The details are outlined in Section 3.3, and the default list is shown in Table 22 below.

Block #	Default Transmit Data
1	Universal Input 1 Measured Value
2	Universal Input 2 Measured Value
3	Universal Input 3 Measured Value
4	Universal Input 4 Measured Value
5	Universal Input 5 Measured Value
6	Universal Input 6 Measured Value
7	Output 1 Target Setpoint Value
8	Output 2 Target Setpoint Value
9	Output 3 Target Setpoint Value
10	Output 4 Target Setpoint Value
11	Output 1 Feedback Measured Value
12	Output 2 Feedback Measured Value
13	Output 3 Feedback Measured Value
14	Output 4 Feedback Measured Value
15	Magnetic Pickup Input Value
16	Digital Input Read State
17	Digital Output Active State
18	Spare Transmit Message 1
19	Spare Transmit Message 2
20	Spare Transmit Message 3

Table 22 – Default CAN Transmit Messages

1.12. CAN Receive Function Block

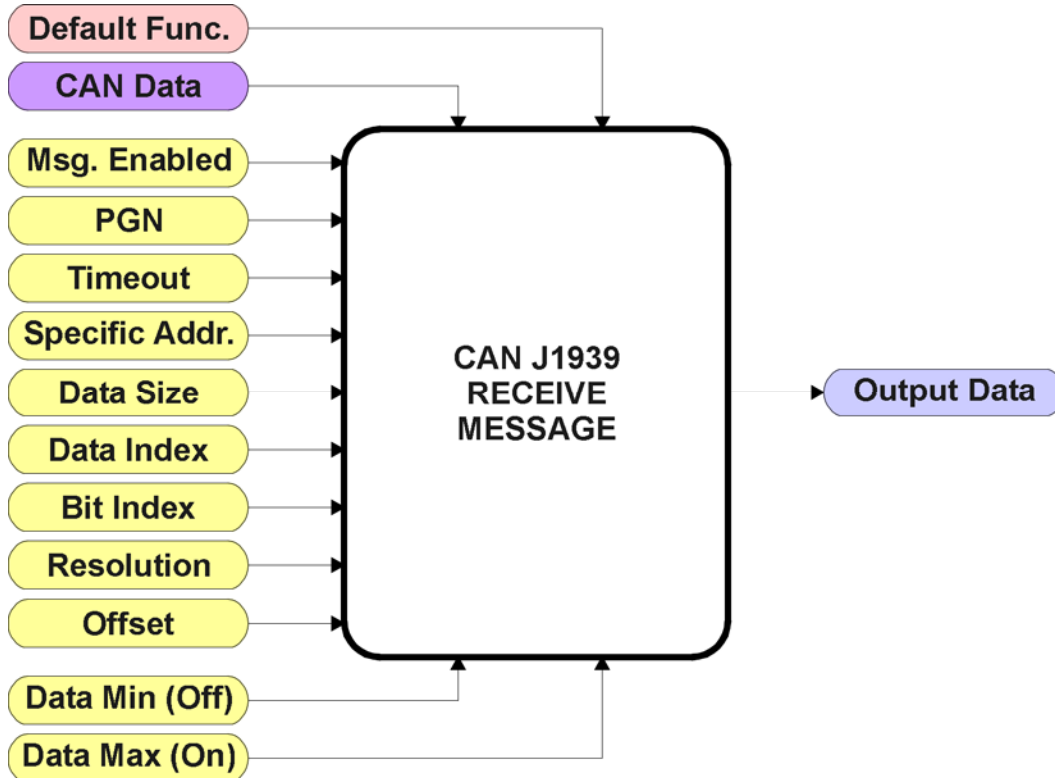



Figure 26 – CAN Receive Function Block

The CAN Receive function block is designed to take any SPN from the J1939 network, and use it as an input to any another function block (i.e. Lookup Table or Output Control).

The “**Received Message Enabled**” is the most important setpoint associated with this function block, and it should be selected first. Changing it will result in other setpoints being enabled/disabled as appropriate. By default ALL received messages are disabled.

 Since the 8i50 can support up to 20 received messages, it can get confusing as to what message performs what function. Therefore, the intended “**Default Receive Function**” is available as a read-only value for each message. Change functions with CAUTION!

Once a message has been enabled, a Lost Communication fault will be flagged if that message is not received off of the bus within the “**Receive Message Timeout**” period. This could trigger a Lost Communication event as described in Section 1.9. In order to avoid timeouts on a heavily saturated network, it is recommended to set it at least three times larger than the expected update rate. To disable the timeout feature, simply set this value to zero, in which case the received message will never trigger a Lost Communication fault.

By default, all control messages are expected to be sent to the 8i50 on Proprietary B PGNs. However, should a PDU1 message be selected, the 8i50 can be setup to receive it from any ECU by setting the “**Specific Address that sends the PGN**” to the Global Address (0xFF). If a specific address is selected instead, then any other ECU sending data on the PGN will be ignored.

The “**Receive Data Size**”, “**Receive Data Index in Array (LSB)**”, “**Receive Bit Index in Byte (LSB)**”, “**Receive Resolution**” and “**Receive Offset**” can all be use to map any SPN supported by the J1939 standard to the output data of the Received function block. The defaults used by the 8i5o are all for proprietary SPNs, and are defined in detail in Section 3.4.

Note: Output Data = CAN Data * Resolution + Offset

As mentioned earlier, a CAN Receive function block can be selected as the source of the control input for the output function blocks. When this is the case, the “**Received Data Min (Off Threshold)**” and “**Received Data Max (On Threshold)**” setpoints become the minimum and maximum values of the X-axis used in the linear calculations. As the names imply, they are also used as the On/Off thresholds for digital input types. These values are in whatever units the output data is AFTER the resolution and offset is applied to the CAN data.

The 8i5o Valve Controller supports up to 20 unique CAN Receive Messages. By default, each message is pre-configured to read a particular type of data. The details are outlined in Section 3.4, and the default list is shown in Table 23 below.

Block #	Default Receive Data
1	Output 1 Command Input Data
2	Output 2 Command Input Data
3	Output 3 Command Input Data
4	Output 4 Command Input Data
5	Output 1 Enable 1 Input Data
6	Output 2 Enable 1 Input Data
7	Output 3 Enable 1 Input Data
8	Output 4 Enable 1 Input Data
9	Output 1 Enable 2 Input Data
10	Output 2 Enable 2 Input Data
11	Output 3 Enable 2 Input Data
12	Output 4 Enable 2 Input Data
13	Output 1 Override Input Data
14	Output 2 Override Input Data
15	Output 3 Override Input Data
16	Output 4 Override Input Data
17	Output 1 Closed Loop Feedback
18	Output 2 Closed Loop Feedback
19	Output 3 Closed Loop Feedback
20	Output 4 Closed Loop Feedback

Table 23 – Default CAN Receive Messages

1.13. Available Control/Input Sources

Throughout Section 1, there have been numerous mentions of ‘mapping’ an output of one function block to a control or input of another. Any time an input is programmable, as shown by the green bubbles in the figures above, it consists of two setpoints. One is the “[Name] Source” and the other the “[Name] Number.” Together, these two setpoints uniquely select how the I/O of the various function blocks are linked together in the custom application.

Below is the full list of the programmable inputs supported by the 8i5o Valve Controller.

Function Block	Input Name
Output X Control (where X =1 to 4)	Control
	Enable 1
	Enable 2
	Override
	PID Target Command
	PID Feedback Input
Digital Output	Control
	Enable 1
Programmable Logic	Table 1 – Lookup Table Block Number
	Table 1 – Condition 1, Argument 1
	Table 1 – Condition 1, Argument 2
	Table 1 – Condition 2, Argument 1
	Table 1 – Condition 2, Argument 2
	Table 1 – Condition 3, Argument 1
	Table 1 – Condition 3, Argument 2
	Table 2 – Lookup Table Block Number
	Table 2 – Condition 1, Argument 1
	Table 2 – Condition 1, Argument 2
	Table 2 – Condition 2, Argument 1
	Table 2 – Condition 2, Argument 2
	Table 2 – Condition 3, Argument 1
	Table 2 – Condition 3, Argument 2
	Table 3 – Lookup Table Block Number
	Table 3 – Condition 1, Argument 1
	Table 3 – Condition 1, Argument 2
	Table 3 – Condition 2, Argument 1
	Table 3 – Condition 2, Argument 2
	Table 3 – Condition 3, Argument 1
Table 3 – Condition 3, Argument 2	
Lookup Table X (where X = 1 to 16)	X-Axis
Math Function X (where X = 1 to 3)	Input 1, Input 2, Input 3 and Input 4
CAN Transmit X (where X = 1 to 20)	Transmit Data

Table 24 – Programmable Inputs

For each of the inputs listed in Table 24, the options for the Source and Number are listed below. Note, not all options would make sense for any particular input, and it is up to the user to program the controller in a logical and functional fashion.

Sources	Range	Notes
Control Source Not Used	N/A	When this is selected, it disables all other setpoints associated with the input in question.
Universal Input Measured	1 to 6	
Magnetic Pickup Frequency/RPM	N/A	Only one available on the unit
Digital Input Read State	1 to 8	Din7 is not available (Magnetic Pickup)
Received CAN J1939 Message	1 to 20	The CAN Receive Messages each have a unique default assigned to them as outlined in Section 1.11
Diagnostic Trouble Code (Rxd)	1 to 5	Will only be valid if the corresponding DTC has a non-zero SPN
PID Function Block	1 to 4	Not user programmable for Output X Control, defaults to appropriate number for block.
Programmable Logic Function Block	1 to 4	User must enable the function block, as it is disabled by default
Lookup Table Function Block	1 to 16	For numbers greater than 4, user must enable the function block, as it is disabled by default
Universal Output Target Value	1 to 4	Can be mapped to a CAN Txd
Universal Output Feedback Value	1 to 4	Input to Output X Drive Diagnostics Can be mapped to a CAN Txd
Digital Output (Lamp) State	N/A	Can be mapped to a CAN Txd
Power Supply Measured	N/A	Input to Power Supply Diagnostics Can be mapped to a CAN Txd
Reflect When a Fault is Detected (Lamp Only)	N/A	Only meant be used as the Digital Output Control Source, to reflect active faults
Control Constant (Logic Arg2 or Math Only)	N/A	Null control for anything expect the Programmable Logic or Math Blocks
Math Function Block	1 to 3	User must enable the function block, as it is disabled by default

Table 25 – Input Sources and Numbers

1.14. Default Valve Controller Program Logic

Below is shown an **extremely** simplified block diagram illustrating the default control logic programmed into the 8i5o Valve Controller.

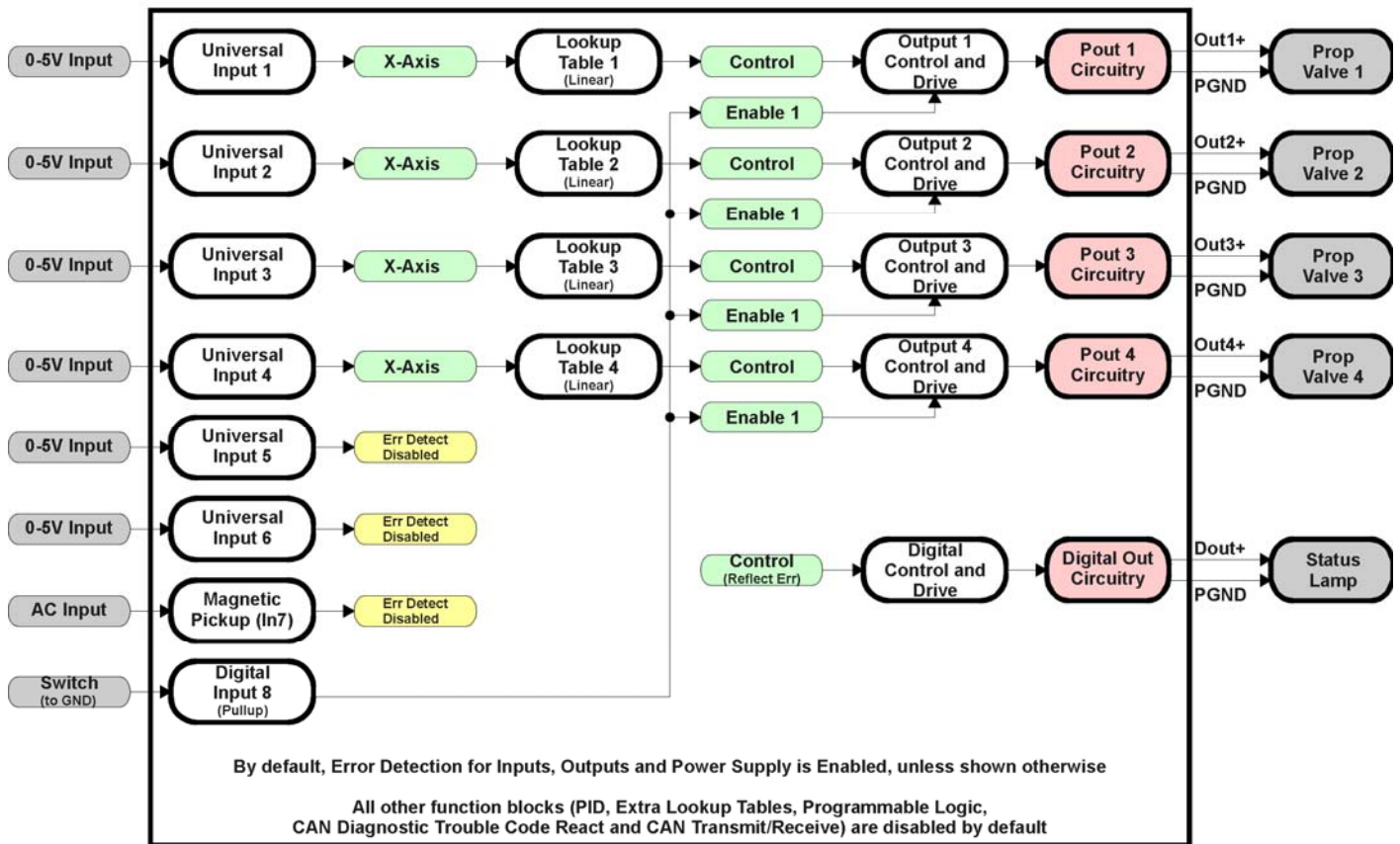
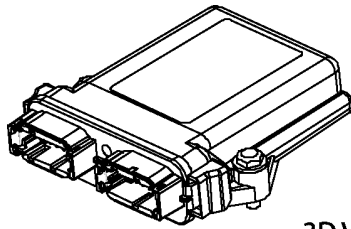

Figure 27 – Default Control Logic

By default, the controller is programmed to be fully self-contained, and does not require a connection to the CAN network to function.

2. INSTALLATION INSTRUCTIONS

2.1. Dimensions and Pinout



3D VIEW
Housing with 24 Pin Receptacle

HOUSING DIMENSIONS

Housing Material: High Temperature Nylon (Black)

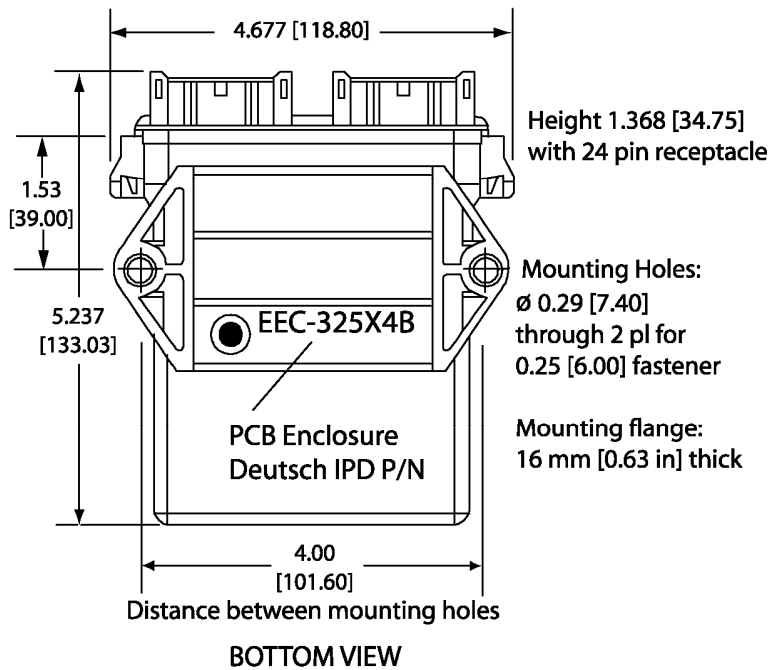

FRONT VIEW 24-PIN RECEPTACLE (NOT TO SCALE)

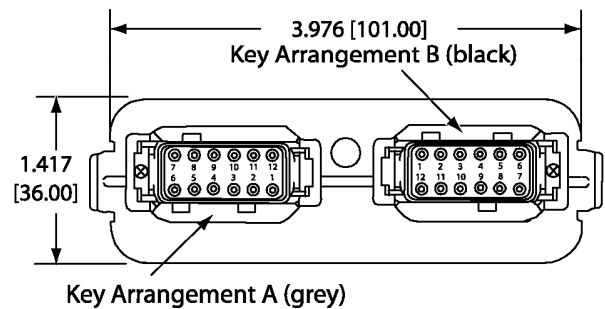

Mating Plug Assemblies for 24-pin receptacle:
Deutsch IPD P/N: DTM06-12SA and DTM06-12SB
with wedgelocks WM12S and contacts
(Contact factory for contact specification.)

Dimensions: inches [mm]
excluding mating plug(s)

Figure 28 – Dimension Drawing

Grey Connector		Black Connector	
Pin #	Function	Pin #	Function
1	CAN_H	1	Universal Input 1 (Uin1)
2	CAN_L	2	Universal Input 2 (Uin2)
3	CAN Shield	3	Universal Input 3 (Uin3)
4	PGND (Output Reference)	4	Universal Input 4 (Uin4)
5	PGND (Output Reference)	5	Universal Input 5 (Uin5)
6	Power – (PGND)	6	Universal Input 6 (Uin6)
7	Power +	7	Digital Input (Active High or Low)
8	Digital Output	8	Magnetic Pickup Input
9	Proportional Output 4 + (Pout4)	9	Magnetic Pickup Reference
10	Proportional Output 3 + (Pout4)	10	Analog GND A (Input Reference)
11	Proportional Output 2 + (Pout4)	11	Analog GND B (Input Reference)
12	Proportional Output 1 + (Pout4)	12	Analog GND C (Input Reference)

Table 26 – Connector Pinout

2.2. Mounting Instructions

SHIELDING

CAN wiring may be shielded using a shielded twisted conductor pair. The shield could be connected to the pin on the grey connector provided for this purpose. When doing this, the other end of the shield wire should be left unconnected.

Other I/O wires should be shielded as required by the application. Shield wires should be connected at the source/load end, and left un-terminated at the 8i50 valve controller.

Shields can be ac grounded at one end and hard grounded at the opposite end to improve shielding effectiveness.

WIRING

Note the operating temperature range. All field wiring must be suitable for that temperature range and conform to applicable standards or codes.

At least 18 or 20 gauge wires must be used for other inputs and outputs.

Refer to the respective Deutsch IPD datasheets for usable insulation diameter ranges and other instructions.

CAN WIRING

The CAN port is electrically isolated from all other circuits. Refer to the CAN 2.0B specification for more information.

Axiomatic recommends that multi-drop networks be constructed using a "daisy chain" or "backbone" configuration with short drop lines.

It is necessary to terminate the network; therefore an external CAN termination is required. No more than two network terminators should be used on any one single network. A terminator is a 121 Ω , 0.25 W, 1% metal film resistor placed between CAN_H and CAN_L terminals at the end two ECUs on a network.

3. OVERVIEW OF J1939 FEATURES

The software was designed to provide flexibility to the user with respect to messages sent to and from the ECU by providing:

- Configurable ECU Instance in the NAME (to allow multiple ECUs on the same network)
- Configurable Transmit PGN and SPN Parameters
- Configurable Receive PGN and SPN Parameters
- Sending DM1 Diagnostic Message Parameters
- Reading and reacting to DM1 messages sent by other ECUs
- Diagnostic Log, maintained in non-volatile memory, for sending DM2 messages

3.1. Introduction To Supported Messages

The ECU is compliant with the standard SAE J1939, and supports the following PGNs

From J1939-21 - Data Link Layer

- Request 59904 (\$00EA00)
- Acknowledgment 59392 (\$00E800)
- Transport Protocol – Connection Management 60416 (\$00EC00)
- Transport Protocol – Data Transfer Message 60160 (\$00EB00)
- PropB Transmit, Default Measured Inputs Feedback Message 65280 (\$00FF00)
- PropB Transmit, Default Proportional Outputs Target Message 65296 (\$00FF10)
- PropB Transmit, Default Proportional Outputs Feedback Message 65312 (\$00FF20)
- PropB Transmit, Default Digital I/O State Feedback Message 65328 (\$00FF30)
- PropB Receive, Default Output Control Data Message 65408 (\$00FF80)
- PropB Receive, Default Output Enable Data Message 65424 (\$00FF90)
- PropB Receive, Default Output Override Data Message 65440 (\$00FFA0)
- PropB Receive, Default PID Feedback Data Message 65456 (\$00FFB0)

Note: Any Proprietary B PGN in the range 65280 to 65535 (\$00FF00 to \$00FFFF) can be selected

Note: The Proprietary A PGN 61184 (\$00EF00) can also be selected for any of the messages

From J1939-73 - Diagnostics

- DM1 – Active Diagnostic Trouble Codes 65226 (\$00FECA)
- DM2 – Previously Active Diagnostic Trouble Codes 65227 (\$00FECB)
- DM3 – Diagnostic Data Clear/Reset for Previously Active DTCs 65228 (\$00FECC)
- DM11 - Diagnostic Data Clear/Reset for Active DTCs 65235 (\$00FED3)
- DM14 – Memory Access Request 55552 (\$00D900)
- DM15 – Memory Access Response 55296 (\$00D800)
- DM16 – Binary Data Transfer 55040 (\$00D700)

From J1939-81 - Network Management

- Address Claimed/Cannot Claim 60928 (\$00EE00)
- Commanded Address 65240 (\$00FED8)

From J1939-71 – Vehicle Application Layer

- Software Identification 65242 (\$00FEDA)

None of the application layer PGNs are supported as part of the default configurations, but they can be selected as desired for either transmit or received function blocks.

Setpoints are accessed using standard Memory Access Protocol (MAP) with proprietary addresses. The Electronic Assistant[®]  (EA) allows for quick and easy configuration of the unit over the CAN network.

3.2. NAME, Address and Software ID

The NAME, Address and Software ID have the following default configurations.

J1939 NAME

The 8i5o Valve Controller ECU has the following defaults for the J1939 NAME. The user should refer to the SAE J1939/81 standard for more information on these parameters and their ranges.

Arbitrary Address Capable	Yes
Industry Group	0, Global
Vehicle System Instance	0
Vehicle System	0, Non-specific system
Function	66, I/O Controller
Function Instance	17, Axiomatic AX021900, 8 Inputs, 5 Outputs
ECU Instance	0, First Instance
Manufacture Code	162, Axiomatic Technologies Corporation
Identity Number	Variable, based on ECU Serial Number

The ECU Instance is a configurable setpoint associated with the NAME. Changing this value will allow multiple ECUs of this type to be distinguishable by other ECUs (including the Electronic Assistant[®] ) when they are all connected on the same network.

ECU Address

The default value of this setpoint is 128 (0x80), which is the preferred starting address for self-configurable ECUs as set by the SAE in J1939 tables B3 to B7. The EA will allow the selection of any address between 0 to 253, and ***it is the user's responsibility to select an address that complies with the standard.*** The user must also be aware that since the unit is arbitrary address capable, if another ECU with a higher priority NAME contends for the selected address, the 8i5o will continue select the next highest address until it find one that it can claim. See J1939/81 for more details about address claiming.

Software Identifier

PGN 65242	Software Identification	- SOFT	
Transmission Repetition Rate:	On request		
Data Length:	Variable		
Extended Data Page:	0		
Data Page:	0		
PDU Format:	254		
PDU Specific:	218 PGN Supporting Information:		
Default Priority:	6		
Parameter Group Number:	65242 (0xFEDA)		
Start Position	Length	Parameter Name	SPN
1	1 Byte	Number of software identification fields	965
2-n	Variable	Software identification(s), Delimiter (ASCII “*”)	234

For the 8i5o Valve Controller ECU, Byte 1 is set to 6, and the identification fields are as follows

(Part Number)*(Version)*(Date)*(Owner)*(Description)*(Serial Number)

EA shows all this information in “General ECU Information”, as shown below

The screenshot shows the 'Electronic Assistant' software window. The title bar reads 'Electronic Assistant'. The menu bar includes 'File', 'View', 'Options', and 'Help'. Below the menu bar are icons for CAN, SP, and SP. The left pane shows a tree view of the 'J1939 CAN Network' containing an 'ECU AX021900, 8 Inputs, 5 Outputs #1' and a 'Setpoint File'. The 'General ECU Information' sub-item is selected. The right pane displays a table of parameters for this ECU.

Parameter	Value	Description
ECU J1939 NAME		PGN 60928. 64-bit ECU Identifier sent in
Arbitrary Address Capable	1	Yes
Industry Group	0	Global
Vehicle System Instance	0	
Vehicle System	0	Non-specific system
Reserved	0	
Function	66	I/O Controller
Function Instance	17	
ECU Instance	0	#1 - First Instance
Manufacturer Code	162	Axiomatic Technologies Corp.
Identity Number	958502	ECU Serial Number: 09309002
ECU Address	128	Reserved for future assignment by SAE
Software ID		PGN 65242 -SOFT
Field #1	AX021900	
Field #2	V2.0.0	
Field #3	SEP 2009	
Field #4	Axiomatic	
Field #5	8 Input, 5 Output	
Field #6	09309002	

Ready

3.3. CAN Transmit Message Defaults

This section outlines the **default** settings of the 8i5o Valve Controller CAN transmissions. Recall, however, that this is a fully programmable unit, such that all these SPNs can be sent on different PGNs if so desired.

In all the messages shown below, not all the transmitted values have an SPN assigned to them, as this ECU only uses the SPNs for diagnostic trouble codes. If the SPN is shown as N/A, this means that the associated value cannot be used to generate DTCs.

The “Measured Inputs Feedback Message” has the following default configuration.

PGN 65280		Measured Inputs Feedback	
Transmission Repetition:	0s (not sent by default, configurable)		
Data Length:	8		
Data Page:	0		
PDU Format:	254		
PDU Specific:	GE	PGN Supporting Information:	
Default Priority:	6		
Parameter Group Number:	65280 (0xFF00)		
Start Position	Length	Parameter Name	SPN
1	1 byte	Universal Input 1 Measured Value	520192
2	1 byte	Universal Input 2 Measured Value	520193
3	1 byte	Universal Input 3 Measured Value	520194
4	1 byte	Universal Input 4 Measured Value	520195
5	1 byte	Universal Input 5 Measured Value	520196
6	1 byte	Universal Input 6 Measured Value	520197
7	2 byte	Magnetic Pickup Measured Value	520198

The “Proportional Outputs Target Message” has the following default configuration.

PGN 65296		Proportional Outputs Target	
Transmission Repetition:	0s (not sent by default, configurable)		
Data Length:	8		
Data Page:	0		
PDU Format:	254		
PDU Specific:	GE	PGN Supporting Information:	
Default Priority:	6		
Parameter Group Number:	65296 (0xFF10)		
Start Position	Length	Parameter Name	SPN
1-2	2 byte	Universal Output 1 Target Value	N/A
3-4	2 byte	Universal Output 2 Target Value	N/A
5-6	2 byte	Universal Output 3 Target Value	N/A
7-8	2 byte	Universal Output 4 Target Value	N/A

The “Proportional Outputs Feedback Message” has the following default configuration.

PGN 65312		Proportional Outputs Feedback	
Transmission Repetition:	0s (not sent by default, configurable)		
Data Length:	8		
Data Page:	0		
PDU Format:	254		
PDU Specific:	GE	PGN Supporting Information:	
Default Priority:	6		
Parameter Group Number:	65312 (0xFF20)		
Start Position	Length	Parameter Name	SPN
1-2	2 byte	Universal Output 1 Current Feedback	520448
3-4	2 byte	Universal Output 2 Current Feedback	520449
5-6	2 byte	Universal Output 3 Current Feedback	520450
7-8	2 byte	Universal Output 4 Current Feedback	520451

The “Digital I/O State Feedback Message” has the following default configuration.

PGN 65328		Digital I/O State Feedback	
Transmission Repetition:	0s (not sent by default, configurable)		
Data Length:	8		
Data Page:	0		
PDU Format:	254		
PDU Specific:	GE	PGN Supporting Information:	
Default Priority:	6		
Parameter Group Number:	65328 (0xFF30)		
Start Position	Length	Parameter Name	SPN
1	1 byte	Digital Input 8 Read State	N/A
2	1 byte	Digital Output (Lamp) State	520704

Universal Input X Measured Value, X = 1 to 6

This value reflects the measured value (after filtering) of the Universal Input. Resolution and data size are automatically updated per the “**Input Sensor Type**” and “**Input Measuring Range**” setpoints of the associated input function block.

0 to 1 Volt Data

Data Length: 1 byte
Resolution: 0.005 V/bit, 0 offset
Data Range: 0 to 1 V

0 to 2.5 Volt Data

Data Length: 1 byte
Resolution: 0.01 V/bit, 0 offset
Data Range: 0 to 2.5 V

0 to 5 Volt Data

Data Length: 1 byte
Resolution: 0.02 V/bit, 0 offset
Data Range: 0 to 5 V

0 to 10 Volt Data

Data Length: 1 byte
Resolution: 0.04 V/bit, 0 offset
Data Range: 0 to 10 V

0(4) to 20mA Current Data

Data Length: 1 byte
Resolution: 0.08mA/bit, 0 offset
Data Range: 0 (4) to 20 mA

Resistive Data

Data Length: 1 byte
Resolution: 1 k Ω /bit, 0 offset
Data Range: 0 to 250 k Ω

Note: This type of input will likely be sent to a Lookup Table to convert it to another unit (i.e. Temperature) before sending it to the CAN bus.

RPM Data

Data Length: 2 byte
Resolution: 1 RPM/bit, 0 offset
Data Range: 0 to 64255 RPM

0 to 50Hz Data:

Data Length: 2 byte
Resolution: 0.01 Hz/bit, 0 offset
Data Range: 0 to 642.55 Hz

10Hz to 1kHz Data:

Data Length: 2 byte
Resolution: 0.1 Hz/bit, 0 offset
Data Range: 0 to 6425.5 Hz

100Hz to 10kHz Data:

Data Length: 2 byte
Resolution: 1 Hz/bit, 0 offset
Data Range: 0 to 64255 Hz

PWM Data

Data Length: 1 byte
Resolution: 0.4%/bit, 0 offset
Data Range: 0 to 100 %

Type: Measured
Suspect Parameter Number: 520192 to 520197 (0x7F000 to 0x7F005, all proprietary SPNs)
Parameter Group Number: 65280

Magnetic Pickup Measured Value

This value reflects the measured value (after filtering) of the Universal Input.

Data Length: 2 byte
Resolution: See Universal Input resolution for RPM and Frequency types
Data Range: See Universal Input resolution for RPM and Frequency data ranges
Type: Measured
Suspect Parameter Number: 520198 (0x7F006, a proprietary SPN)
Parameter Group Number: 65280

Digital Input X State, where X = 8 (default, could be 1 to 6 as well)

- 00 Input OFF
- 01 Input ON
- 02 Input Error (not used in this ECU)
- 03 Input Not Applicable (i.e. input disabled)

Data Length: 1 byte
Resolution: 1 state/bit, 0 offset
Type: Measured
Suspect Parameter Number: N/A
Parameter Group Number: 65328

Digital Output (Lamp) State

00	Output OFF
01	Output ON
02	Output Error
03	Output Not Applicable

Data Length: 1 byte
Resolution: 1 state/bit, 0 offset
Type: Measured
Suspect Parameter Number: 520704 (0x7F200, a proprietary SPN)
Parameter Group Number: 65328

Universal Output X Target Value, where X = 1 to 4

This value reflects the target value for the proportional output as determined by the control logic function block. The value will be in whatever unit is appropriate for the output type. For current output types, it is recommended to use the Feedback message (below) instead.

Current Output

Resolution: 1 mA/bit, 0 offset
Data Range: 0 to 64255 mA

Voltage Output

Resolution: 0.01 V/bit, 0 offset
Data Range: 0 to 642.55 V

PWM Output

Resolution: 0.01 %/bit, 0 offset
Data Range: 0 to 642.55 %

Data Length: 2 byte
Type: Calculated
Suspect Parameter Number: N/A
Parameter Group Number: 65296

Universal Output Current X Feedback, where X = 1 to 4

This value reflects the measured current sourced from the proportional output drive circuit.

Data Length: 2 byte
Resolution: 1mA/bit, 0 offset
Data Range: 0 to 64255 mA
Type: Measured
Suspect Parameter Number: 520448 to 520451 (0x7F100 to 0x7F103, all proprietary SPNs)
Parameter Group Number: 65312

3.4. CAN Receive Message Defaults

This section outlines the **default** settings of the 8i50 Valve Controller CAN receive channels, used as inputs to the various function blocks supported by this ECU. Recall, however, that this is a fully programmable unit, such that all these SPNs can be received on different PGNs if so desired.

In all the messages shown below, none of the received values have an SPN assigned to them, as this ECU only uses the SPNs for diagnostic trouble codes. To have the 8i50 react to a DTC sent by another ECU on the network on a DM1, use the DTC React Function block instead.

By default, all CAN Receive Messages are disabled, as they are not part of the factory set logic shown in Figure 27. However, should one or all of them be enabled by the user, the default settings for each message are as outlined in this section.

The “Output Control Data Message” has the following default configuration.

PGN 65408		Output Control Data	
Transmission Repetition:		100ms (default, configurable)	
Data Length:		8	
Data Page:		0	
PDU Format:		254	
PDU Specific:		GE	PGN Supporting Information:
Default Priority:		6	
Parameter Group Number:		65408 (0xFF80)	
Start Position	Length	Parameter Name	SPN
1	1 byte	Output 1 Command Input Data	N/A
2	1 byte	Output 2 Command Input Data	N/A
3	1 byte	Output 3 Command Input Data	N/A
4	1 byte	Output 4 Command Input Data	N/A

The “PID Feedback Data Message” has the following default configuration.

PGN 65456		PID Feedback Data	
Transmission Repetition:		100ms (default, configurable)	
Data Length:		8	
Data Page:		0	
PDU Format:		254	
PDU Specific:		GE	PGN Supporting Information:
Default Priority:		6	
Parameter Group Number:		65456 (0xFFB0)	
Start Position	Length	Parameter Name	SPN
1	1 byte	Output 1 Closed Loop Feedback	N/A
2	1 byte	Output 2 Closed Loop Feedback	N/A
3	1 byte	Output 3 Closed Loop Feedback	N/A
4	1 byte	Output 4 Closed Loop Feedback	N/A

The “Output Enable Data Message” has the following default configuration.

PGN 65424		Output Enable Data	
Transmission Repetition:	100ms (default, configurable)		
Data Length:	8		
Data Page:	0		
PDU Format:	254		
PDU Specific:	GE	PGN Supporting Information:	
Default Priority:	6		
Parameter Group Number:	65424 (0xFF90)		
Start Position	Length	Parameter Name	SPN
1	1 byte	Output 1 Enable 1 Input Data	N/A
2	1 byte	Output 2 Enable 1 Input Data	N/A
3	1 byte	Output 3 Enable 1 Input Data	N/A
4	1 byte	Output 4 Enable 1 Input Data	N/A
5	1 byte	Output 1 Enable 2 Input Data	N/A
6	1 byte	Output 2 Enable 2 Input Data	N/A
7	1 byte	Output 3 Enable 2 Input Data	N/A
8	1 byte	Output 4 Enable 2 Input Data	N/A

The “Output Override Data Message” has the following default configuration.

PGN 65440		Output Override Data	
Transmission Repetition:	100ms (default, configurable)		
Data Length:	8		
Data Page:	0		
PDU Format:	254		
PDU Specific:	GE	PGN Supporting Information:	
Default Priority:	6		
Parameter Group Number:	65440 (0xFFA0)		
Start Position	Length	Parameter Name	SPN
1	1 byte	Output 1 Override Input Data	N/A
2	1 byte	Output 2 Override Input Data	N/A
3	1 byte	Output 3 Override Input Data	N/A
4	1 byte	Output 4 Override Input Data	N/A

Output X Command Input Data, where X = 1 to 4

Default value used when a *'Received CAN J1939 Message'* is used as the control source for the Output Control logic function block (or another block that is linked to the output control.)

Data Length: 1 byte
Resolution: 0.4%/bit, 0 offset
Data Range: 0 to 100 %
Type: Input
Suspect Parameter Number: N/A
Parameter Group Number: 65408

Output X Enable Y Input Data, where X = 1 to 4 and Y = 1 or 2

Default value used when a *'Received CAN J1939 Message'* is used as an enable source for the Output Control logic function block.

00 Enable Signal is OFF
01 Enable Signal is ON
02 Error (automatic disable)
03+ Ignored
Data Length: 2 bits
Resolution: 1 state/bit, 0 offset
Type: Input
Suspect Parameter Number: N/A
Parameter Group Number: 65424

Output X Override Input Data, where X = 1 to 4

Default value used when a *'Received CAN J1939 Message'* is used as the override source for the Output Control logic function block.

00 Override Signal is OFF
01 Override Signal is ON
02 Error (override disabled)
03+ Ignored
Data Length: 2 bits
Resolution: 1 state/bit, 0 offset
Type: Input
Suspect Parameter Number: N/A
Parameter Group Number: 65440

Output X Closed Loop Feedback, where X = 1 to 4

Default value used when a *'Received CAN J1939 Message'* is used as the feedback source for a proportional output PID control function block.

Data Length: 1 byte
Resolution: 0.4 [Data]/bit, 0 offset
Data Range: 0 to 100.0
Type: Input
Suspect Parameter Number: N/A
Parameter Group Number: 65456

4. ECU SETPOINTS ACCESSED WITH ELECTRONIC ASSISTANT

Many setpoints have been reference throughout this manual. This section describes in detail each setpoint, and their defaults and ranges. For more information on how each setpoint is used by the 8i5o Valve Controller, refer to the relevant section of the User Manual.

4.1. Miscellaneous Setpoints

The Miscellaneous setpoints primarily deal with the CAN Network. Refer to the notes for more information about each setpoint.

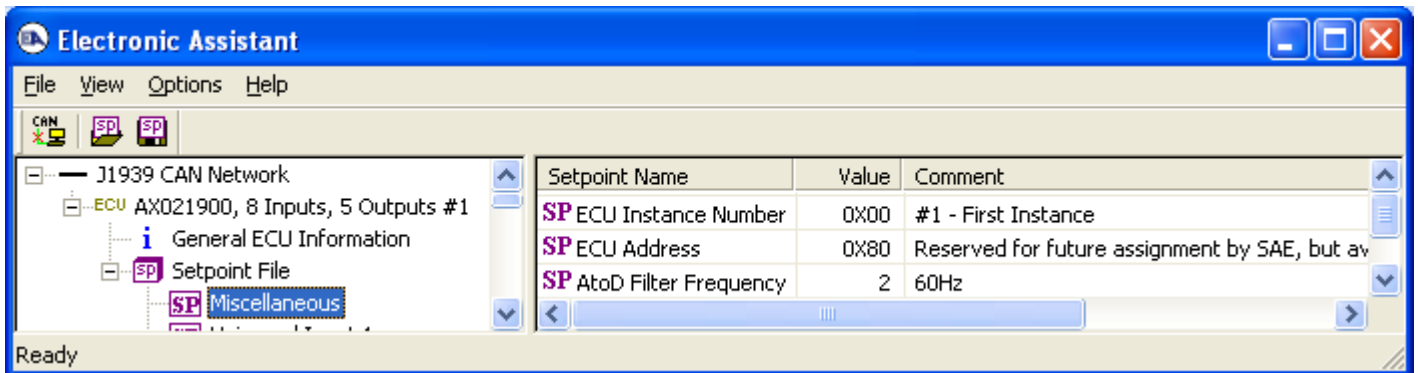

Screen Capture of Default Miscellaneous Setpoints

Name	Range	Default	Notes
ECU Instance Number	Drop List	0, #1 – First Instance	Per J1939-81
ECU Address	0 to 253	128	Preferred address for a self-configurable ECU
AtoD Filter Frequency	Drop List	2, 60Hz	0 = None, 1 = 50Hz, 2 = 60Hz, 3 = Both This filter used on all values measured by ADC

4.2. Universal Input Setpoints

The Universal Input function block is defined in Section 1.2. Please refer there for detailed information about how all these setpoints are used.

Setpoint Name	Value	Comment
SP Input Sensor Type	1	Voltage
SP Pulses per Revolution		Parameter not used, Input not setup as an RPM pickup
SP Input Measuring Range	2	0 to 5V
SP Minimum Error	0.20	V
SP Minimum Range	0.50	V
SP Maximum Range	4.50	V
SP Maximum Error	4.80	V
SP Digital Input Type		Parameter not used with this input type
SP Pullup/Pulldown Resistor		Parameter not used with this input type
SP Debounce Period		Parameter not used with this input type
SP Software Filter Type	0	No Filter
SP Software Filter Constant		Parameter not used with this Filter Type
SP Filter Sampling Period		Parameter not used with this Filter Type
SP Filter Power for Divisor		Parameter not used with this Filter Type
SP Filter Coefficient for Input(n)		Parameter not used with this Filter Type
SP Filter Coefficient for Input(n-1)		Parameter not used with this Filter Type
SP Filter Coefficient for Input(n-2)		Parameter not used with this Filter Type
SP Filter Coefficient for Input(n-3)		Parameter not used with this Filter Type
SP Filter Coefficient for Output(n-1)		Parameter not used with this Filter Type
SP Filter Coefficient for Output(n-2)		Parameter not used with this Filter Type
SP Filter Coefficient for Output(n-3)		Parameter not used with this Filter Type
SP Fault Detection is Enabled	1	True
SP Hysteresis to Clear Fault	0.100	V
SP Event Generates a DTC in DM1	0	False
SP Event Cleared Only by DM11		Parameter not used with this configuration
SP Lamp Set by Event in DM1		Parameter not used with this configuration
SP SPN for Event used in DTC		Parameter not used with this configuration
SP FMI for Event used in DTC		Parameter not used with this configuration
SP Delay Before Sending DM1		Parameter not used with this configuration

Screen Capture of Default Universal Input 1 Setpoints

By default, a 0-5V input type does not apply any software filtering. Also, as stated in Section 1.14, the controller is programmed to be self-contained, and does not send or receive CAN data, including diagnostic messages. While fault detection is enabled on Universal Inputs 1 to 4 (as they are used to control Outputs 1 to 4 respectively), faults will not generate DM1 messages.

Therefore, for completeness, a screen capture has been included to also show the default values of the Filtering Function Block (Section 1.8) and the Diagnostic Function Block (Section 1.9) for this input.

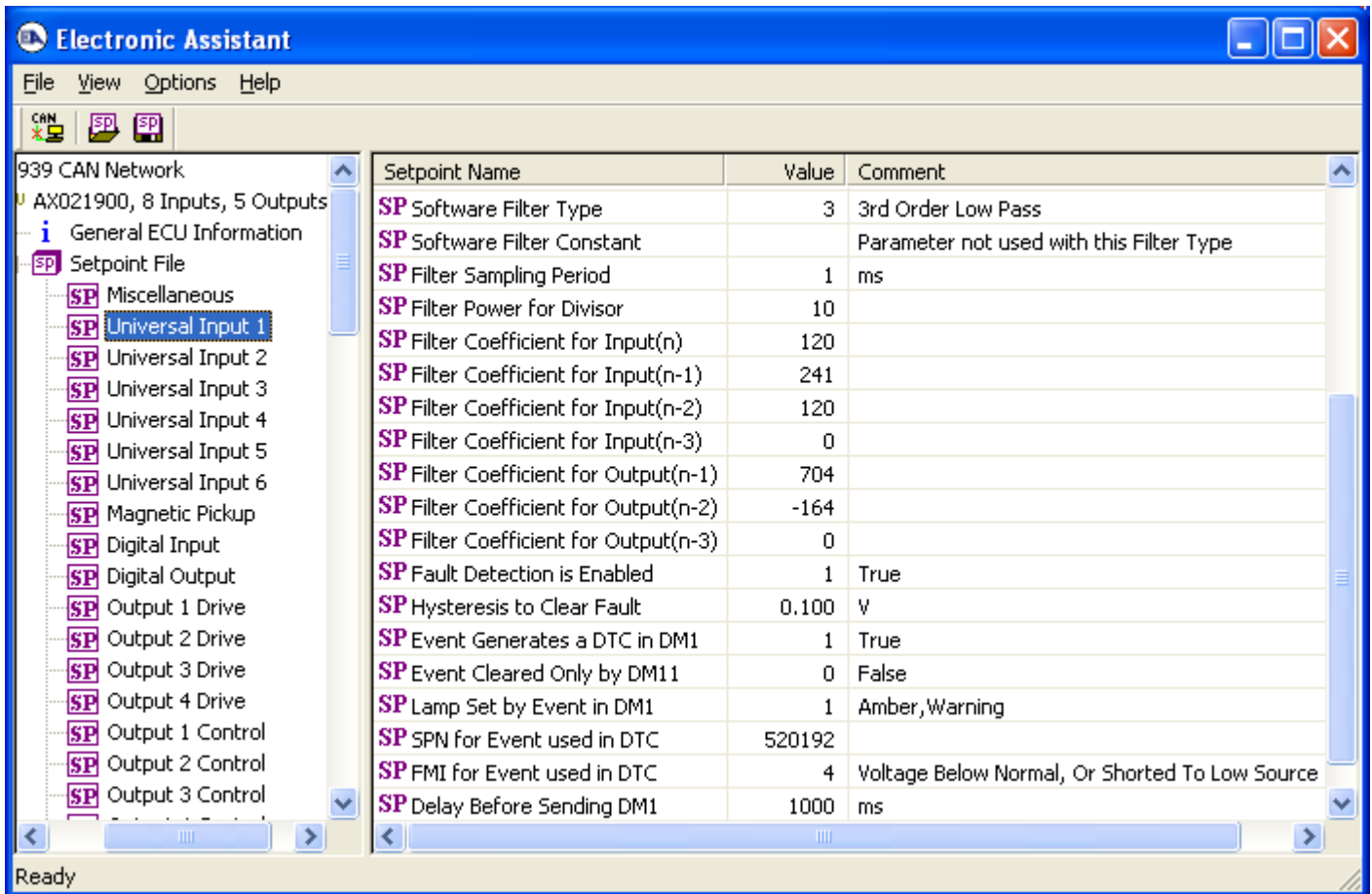

Screen Capture of Universal Input 1 with Active Software Filter, and Sending DM1 Messages

Type	Range	Minimum Error	Minimum Range	Maximum Range	Maximum Error	Hysteresis
Voltage	0-1V	0.05 [V]	0.10 [V]	1.00 [V]	1.10 [V]	0.025 [V]
	0-2.5V	0.10 [V]	0.25 [V]	2.50 [V]	2.75 [V]	0.050 [V]
	0-5V	0.20 [V]	0.50 [V]	4.50 [V]	4.80 [V]	0.100 [V]
	0-10V	0.20 [V]	0.50 [V]	9.50 [V]	9.80 [V]	0.250 [V]
Current	0-20mA	0.00 [mA]	0.00 [mA]	20.00 [mA]	22.00 [mA]	0.250 [mA]
	4-20mA	1.00 [mA]	4.00 [mA]	20.00 [mA]	22.00 [mA]	0.250 [mA]
Resistive	N/A	0.025 [kΩ]	0.100 [kΩ]	200.0 [kΩ]	250.0 [kΩ]	0.010 [kΩ]
Frequency/ RPM	RPM	50 [RPM]	100 [RPM]	2500 [RPM]	2600 [RPM]	10 [RPM]
	0.5 to 50 Hz	0.10 [Hz]	1.00 [Hz]	50.00 [Hz]	55.00 [Hz]	0.200 [Hz]
	10Hz to 1kHz	1.0 [Hz]	10.0 [Hz]	1000.0 [Hz]	1010.0 [Hz]	5.0 [Hz]
PWM	100Hz to 10kHz	10 [Hz]	100 [Hz]	10000 [Hz]	10100 [Hz]	10 [Hz]
	Low Freq [<1kHz]	1.00 [%]	5.00 [%]	95.00 [%]	99.00 [%]	1.00 [%]
	High Freq [>100Hz]	1.00 [%]	5.00 [%]	95.00 [%]	99.00 [%]	1.00 [%]
Digital	N/A	N/A	0.00	1.00	N/A	N/A

Setpoint Defaults Based on Type and Range

Name	Range	Default	Notes
Input Sensor Type	Drop List	1, Voltage	See Table 1
Pulses per Revolution	0 to 1,000	1	0 means measured in Hz
Input Measuring Range	Drop List	2, 0 to 5V	See Tables 2 thru 5 for ranges based on type
Minimum Error	0.00 to Minimum Range	0.20V	Default values for these setpoints are dependent on Type and Range. These values are automatically updated by the ECU when the Type/Range setpoints are changed. See Table above for the complete list.
Minimum Range	Minimum Error to Maximum Range	0.50V	
Maximum Range	Minimum Range to Maximum Error	4.50V	
Maximum Error	Maximum Range to Limit (see notes)	4.80V	
Software Filter Type	Drop List	0, No Filter	See Table 19
Software Filter Constant	1 to 1,000	10	Used with Moving or Repeating Average Filters
Filter Sampling Period	1 to 1,000 ms	10 ms	Used with 3 rd Order Low Pass, otherwise called every 1ms
Filter Power for Divisor	0 to 16	10	2 ^{Power} is used in fixed point math for 3 rd Order Low Pass
Filter Coefficient for Input(n)	-10,000 to 10,000	120	Used with 3 rd Order Low Pass $X = Y * 2^{Power}$
Filter Coefficient for Input(n-1)	-10,000 to 10,000	241	See above
Filter Coefficient for Input(n-2)	-10,000 to 10,000	120	See above
Filter Coefficient for Input(n-3)	-10,000 to 10,000	0	See above
Filter Coefficient for Ouput(n-1)	-10,000 to 10,000	704	See above
Filter Coefficient for Ouput(n-2)	-10,000 to 10,000	-164	See above
Filter Coefficient for Ouput(n-3)	-10,000 to 10,000	0	See above
Fault Detection is Enabled	False or True	True (Inputs 1 to 4) False (Inputs 5 and 6)	See Section 1.9
Hysteresis to Clear Fault	0.01 to 50.00	0.10V	See Section 1.9
Event Generates a DTC in DM1	False or True	False	See Section 1.9
Event Cleared Only by DM11	False or True	False	See Section 1.9
Lamp Set by Event in DM1	Drop List	1, Amber, Warning	See Section 1.9
SPN for Event used in DTC	1 to 524287	520192 (\$7F000) Uin1 520192 (\$7F001) Uin2 520193 (\$7F002) Uin3 520194 (\$7F003) Uin4 520195 (\$7F004) Uin5 520196 (\$7F005) Uin6	See Section 1.9 and 3.3
FMI for Event used in DTC	Drop List	4, Voltage Below Normal	See Section 1.9 (low FMI)
Delay Before Sending DM1	0 to 60,000 ms	1000 ms	See Section 1.9

4.3. Magnetic Pickup Setpoints

Setpoint Name	Value	Comment
SP Input Sensor Type	4	Freq/RPM
SP Pulses per Revolution	1	
SP Input Measuring Range	0	0.5Hz to 50Hz
SP Minimum Error	50.00	RPM
SP Minimum Range	100.00	RPM
SP Maximum Range	2500.00	RPM
SP Maximum Error	2600.00	RPM
SP Software Filter Type	0	No Filter
SP Software Filter Constant		Parameter not used with this Filter Type
SP Filter Sampling Period		Parameter not used with this Filter Type
SP Filter Power for Divisor		Parameter not used with this Filter Type
SP Filter Coefficient for Input(n)		Parameter not used with this Filter Type
SP Filter Coefficient for Input(n-1)		Parameter not used with this Filter Type
SP Filter Coefficient for Input(n-2)		Parameter not used with this Filter Type
SP Filter Coefficient for Input(n-3)		Parameter not used with this Filter Type
SP Filter Coefficient for Output(n-1)		Parameter not used with this Filter Type
SP Filter Coefficient for Output(n-2)		Parameter not used with this Filter Type
SP Filter Coefficient for Output(n-3)		Parameter not used with this Filter Type
SP Fault Detection is Enabled	0	False
SP Hysteresis to Clear Fault		Parameter not used with this configuration
SP Event Generates a DTC in DM1		Parameter not used with this configuration
SP Event Cleared Only by DM11		Parameter not used with this configuration
SP Lamp Set by Event in DM1		Parameter not used with this configuration
SP SPN for Event used in DTC		Parameter not used with this configuration
SP FMI for Event used in DTC		Parameter not used with this configuration
SP Delay Before Sending DM1		Parameter not used with this configuration

Screen Capture of Magnetic Pickup Default Setpoints

These setpoints are identical in every way to the Universal Input, except that the “**Input Sensor Type**” is a read-only parameter as ‘Freq/RPM’. Also, the fault detection is disabled by default, as this input is not used as part of the factory programming shown in Figure 27 in Section 1.15

4.4. Digital Input Setpoints

The Digital Input function block is defined in Section 1.2. Please refer there for detailed information about how all these setpoints are used. This function block is also associated with the Universal Inputs when they are setup for “**Input Sensor Type**” equals *Digital*. However, they do not have the 10kΩ pullup/pulldown option available on Digital Input 8, so that setpoint is read-only as OFF.

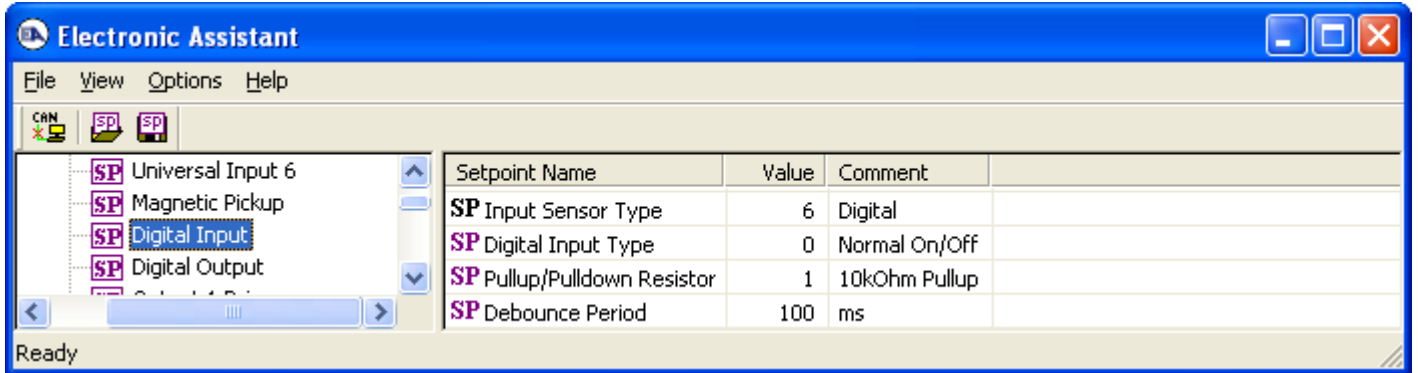

Screen Capture of Default Digital Input 1 Setpoints

Name	Range	Default	Notes
Input Sensor Type	Digital	Digital	Read-Only for Din8
Digital Input Type	Drop List	0, Normal On/Off	See Table 6
Pullup/Pulldown Resistor	Drop List	1, 10kOhm Pullup	Only with Digital Input 8
Debounce Period	1 to 1,000 ms	100 ms	See Figure 4

4.5. Digital Output Setpoints

The Digital Output Control function block is defined in Section 1.3. Please refer there for detailed information about how all these setpoints are used.

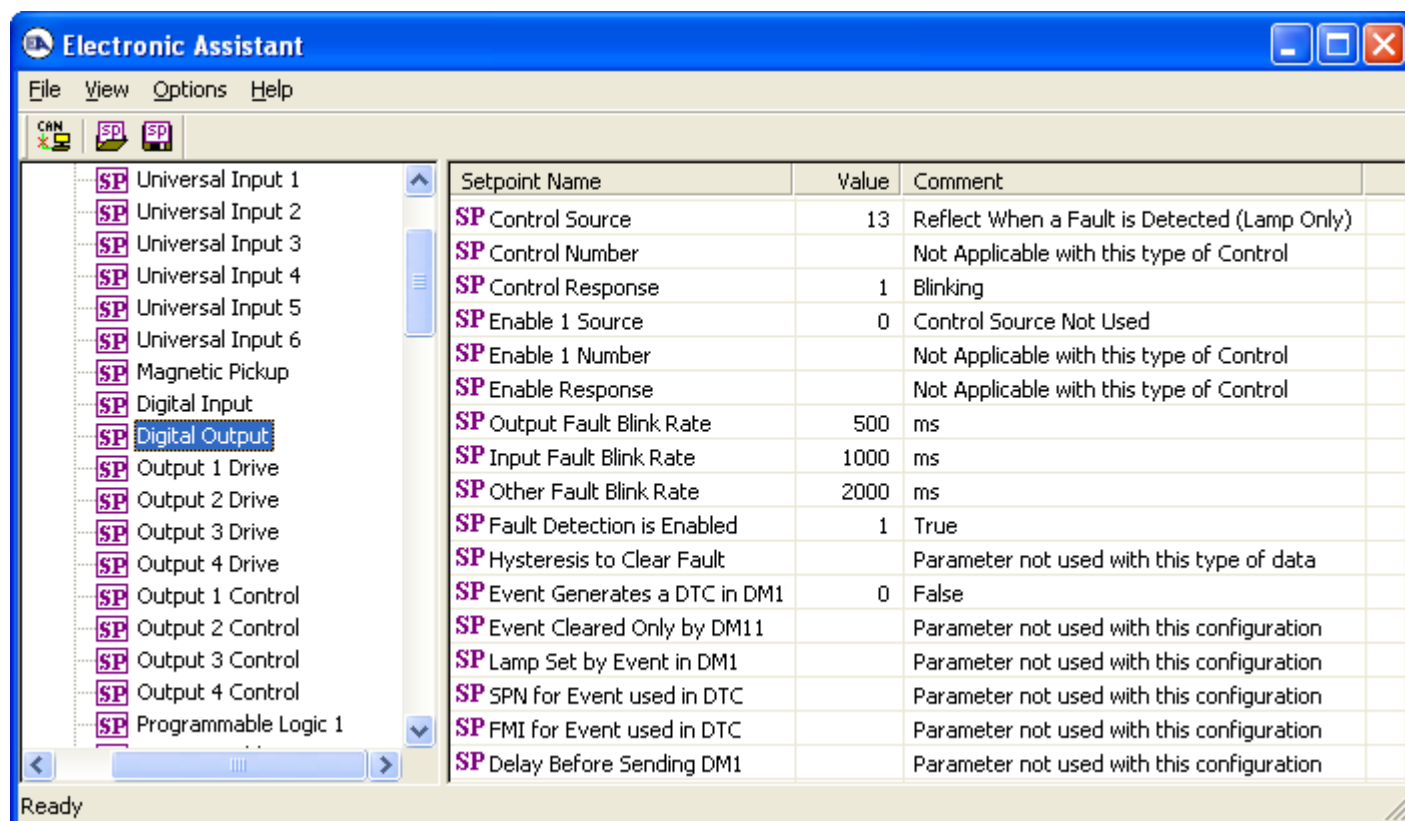

Screen Capture of Default Digital Output Setpoints

Name	Range	Default	Notes
Control Source	Drop List	13, Reflect When a Fault is Detected (Lamp Only)	See Table 25
Control Number	Per Source	N/A	See Table 25
Control Response	Drop List	1, Blinking	See Table 11
Enable 1 Source	Drop List	0, Control Source Not Used	See Table 25
Enable 1 Number	Per Source	N/A	See Table 25
Enable 1 Response	Drop List	N/A	See Table 12
Output Fault Blink Rate	100 to 5,000 ms	500 ms	Output 1 to 4
Input Fault Blink Rate	100 to 5,000 ms	1000 ms	Inputs 1 to 6, Magnetic Pickup
Other Fault Blink Rate	100 to 5,000 ms	2000 ms	Power or Communication
Fault Detection is Enabled	False or True	True	See Section 1.9
Hysteresis to Clear Fault	N/A	N/A	
Event Generates a DTC in DM1	False or True	False	See Section 1.9
Event Cleared Only by DM11	False or True	False	See Section 1.9
Lamp Set by Event in DM1	Drop List	1, Amber, Warning	See Section 1.9
SPN for Event used in DTC	1 to 524287	520704 (\$7F200)	See Section 1.9 and 3.3
FMI for Event used in DTC	Drop List	31, Condition Exists	See Section 1.9
Delay Before Sending DM1	0 to 60,000 ms	1000 ms	See Section 1.9

4.6. Output Drive Setpoints

The Output Drive function block is defined in Section 1.4. Please refer there for detailed information about how all these setpoints are used.

Each function block also has associated with it an Output X Control function block. Output 1 through to Output 4 are completely independent of each other.

Setpoint Name	Value	Comment
SP Output Type	1	Proportional Current
SP Output At Minimum Command	0	mA
SP Output At Maximum Command	1500	mA
SP Output At Override Command	2000	mA
SP Dither Frequency	200	Hz
SP Dither Amplitude	0	mA
SP Ramp Up (Min to Max)	1000	ms
SP Ramp Down (Max to Min)	1000	ms
SP PWM Output Frequency		Parameter not used with this output type
SP Hold Current		Parameter not used with this output type
SP Hotshot Current		Parameter not used with this output type
SP Hotshot Time		Parameter not used with this output type
SP Software Filter Type	2	Repeating Average
SP Software Filter Constant	100	
SP Filter Sampling Period		Parameter not used with this Filter Type
SP Filter Power for Divisor		Parameter not used with this Filter Type
SP Filter Coefficient for Input(n)		Parameter not used with this Filter Type
SP Filter Coefficient for Input(n-1)		Parameter not used with this Filter Type
SP Filter Coefficient for Input(n-2)		Parameter not used with this Filter Type
SP Filter Coefficient for Input(n-3)		Parameter not used with this Filter Type
SP Filter Coefficient for Output(n-1)		Parameter not used with this Filter Type
SP Filter Coefficient for Output(n-2)		Parameter not used with this Filter Type
SP Filter Coefficient for Output(n-3)		Parameter not used with this Filter Type
SP Fault Detection is Enabled	1	True
SP Hysteresis to Clear Fault	50.000	mA
SP Event Generates a DTC in DM1	0	False
SP Event Cleared Only by DM11		Parameter not used with this configuration
SP Lamp Set by Event in DM1		Parameter not used with this configuration
SP SPN for Event used in DTC		Parameter not used with this configuration
SP FMI for Event used in DTC		Parameter not used with this configuration
SP Delay Before Sending DM1		Parameter not used with this configuration

Screen Capture of Default Output 1 Drive Setpoints

Name	Range	Default	Notes
Output Type	Drop List	1, Proportional Current	See Table 9
Output at Minimum Command	0 to Limit	0 mA	Current, Limit = 2500 mA Voltage, Limit = 48.0V PWM, Limit = 100.0 %
Output at Maximum Command	0 to Limit	1500 mA	
Output at Override Command	0 to Limit	2000 mA	
Dither Frequency	50 to 400 Hz	200 Hz	
Dither Amplitude	0 to 500 mA	0 mA	0 = No Dithering
Ramp Up (Min to Max)	0 to 10,000 ms	1000 ms	
Ramp Down (Max to Min)	0 to 10,000 ms	1000 ms	
PWM Output Frequency	250 to 1,000 Hz	500Hz	Only configurable if no voltage or current output types enabled.
Hold Current	0 to 2500 mA	500 mA	Only used with Hotshot output type
Hotshot Current	0 to 2500 mA	2000 mA	
Hotshot Time	500 to 10,000 ms	1000 ms	
Software Filter Type	Drop List	2, Repeating Average	See Table 19
Software Filter Constant	1 to 1,000	100	Used with Moving or Repeating Average Filters
Filter Sampling Period	1 to 1,000 ms	10 ms	Used with 3 rd Order Low Pass, otherwise called every 1ms
Filter Power for Divisor	0 to 16	10	2 ^{Power} is used in fixed point math for 3 rd Order Low Pass
Filter Coefficient for Input(n)	-10,000 to 10,000	120	Used with 3 rd Order Low Pass $X = Y * 2^{Power}$
Filter Coefficient for Input(n-1)	-10,000 to 10,000	241	See above
Filter Coefficient for Input(n-2)	-10,000 to 10,000	120	See above
Filter Coefficient for Input(n-3)	-10,000 to 10,000	0	See above
Filter Coefficient for Ouput(n-1)	-10,000 to 10,000	704	See above
Filter Coefficient for Ouput(n-2)	-10,000 to 10,000	-164	See above
Filter Coefficient for Ouput(n-3)	-10,000 to 10,000	0	See above
Fault Detection is Enabled	False or True	True	See Section 1.9
Hysteresis to Clear Fault	0.01 to 50.00	50.00 mA	See Section 1.9
Event Generates a DTC in DM1	False or True	False	See Section 1.9
Event Cleared Only by DM11	False or True	False	See Section 1.9
Lamp Set by Event in DM1	Drop List	1, Amber, Warning	See Section 1.9
SPN for Event used in DTC	1 to 524287	520448 (\$7F100) Out1 520449 (\$7F101) Out2 520450 (\$7F102) Out3 520451 (\$7F103) Out4	See Section 1.9 and 3.3
FMI for Event used in DTC	Drop List	5, Open Circuit	See Section 1.9 (low FMI)
Delay Before Sending DM1	0 to 60,000 ms	1000 ms	See Section 1.9

4.7. Output Control Setpoints

The Output Control function block is defined in Section 1.3. Please refer there for detailed information about how all these setpoints are used.

Each function block also has associated with it an Output X Drive function block. Output 1 through to Output 4 are completely independent of each other.

Setpoint Name	Value	Comment
SP Control Source	8	Lookup Table Function Block
SP Control Number	1	Lookup Table 1
SP Fault Response	0	Shutoff
SP Enable 1 Source	3	Digital Input Read State
SP Enable 1 Number	8	Digital Input 8
SP Enable 1 Response	0	Enable When On, Else Shutoff
SP Enable 2 Source	0	Control Source Not Used
SP Enable 2 Number		Not Applicable with this type of Control
SP Enable 2 Response		Not Applicable with this type of Control
SP Override Source	0	Control Source Not Used
SP Override Number		Not Applicable with this type of Control
SP Override Response		Not Applicable with this type of Control
SP PID Target Command Source		Not Applicable with this type of Control
SP PID Target Command Number		Not Applicable with this type of Control
SP PID Feedback Input Source		Not Applicable with this type of Control
SP PID Feedback Input Number		Not Applicable with this type of Control
SP PID Response Profile		Not Applicable with this type of Control
SP PID Setpoint Control Target		Not Applicable with this type of Control
SP PID Delta Tolerance		Not Applicable with this type of Control
SP PID Loop Update Rate		Not Applicable with this type of Control
SP PID Gain Coefficient, G		Not Applicable with this type of Control
SP PID Integral Time Coeff, Ti		Not Applicable with this type of Control
SP PID Derivative Time Coeff, Td		Not Applicable with this type of Control
SP PID Integral Coefficient, Ki		Not Applicable with this type of Control
SP PID Derivative Coefficient, Kd		Not Applicable with this type of Control

Screen Capture of Default Output 1 Control Setpoints

Name	Range	Default	Notes
Control Source	Drop List	8, Lookup Table Function Block	See Table 25
Control Number	Per Source	Same as Output Drive Number	See Table 25
Fault Response	Drop List	0, Shutoff	See Table 8
Enable 1 Source	Drop List	3, Digital Input Read State	See Table 25
Enable 1 Number	Per Source	8, Digital Input 8	See Table 25
Enable 1 Response	Drop List	0, Enable When On, Else Shutoff	See Table 7
Enable 2 Source	Drop List	0, Control Source Not Used	See Table 25
Enable 2 Number	Per Source	N/A	See Table 25
Enable 2 Response	Drop List	N/A	See Table 7
Override Source	Drop List	0, Control Source Not Used	See Table 25
Override Number	Per Source	N/A	See Table 25
Override Response	Drop List	N/A	0 = Override When On 1 = Override When Off
PID Target Input Source	Drop List	Received CAN J1939 Message	
PID Target Input Number	Per Source	Same as Output Drive Number	Default Output X Command Input Data (per Table 23)
PID Feedback Input Source	Drop List	1, Universal Input Measured	See Table 25
PID Feedback Input Number	Per Source	Same as Output Drive Number	See Table 25
PID Response Profile	Drop List	0, Single Output	See Table 9
PID Setpoint Control Target	-1,000,000 to 1,000,000	50.00 mA	
PID Delta Tolerance	0 to 100	1.00	Units match Output Type
PID Loop Update Rate	1 to 60,000 ms	10 ms	1 ms resolution
PID Gain Coefficient, G	0.1 to 10	0.5	See Figure 14
PID Integral Time Coeff, Ti	0.001 to 10 Sec	0.005 Sec	0.001 Sec (1ms) resolution
PID Derivative Time Coeff, Td	0.001 to 10 Sec	0.001 Sec	0.001 Sec (1ms) resolution
PID Integral Coefficient, Ki	0 to 10	1.0	0 disables integral, PD ctrl
PID Derivative Coefficient, Kd	0 to 10	1.0	0 disables derivative, PI ctrl

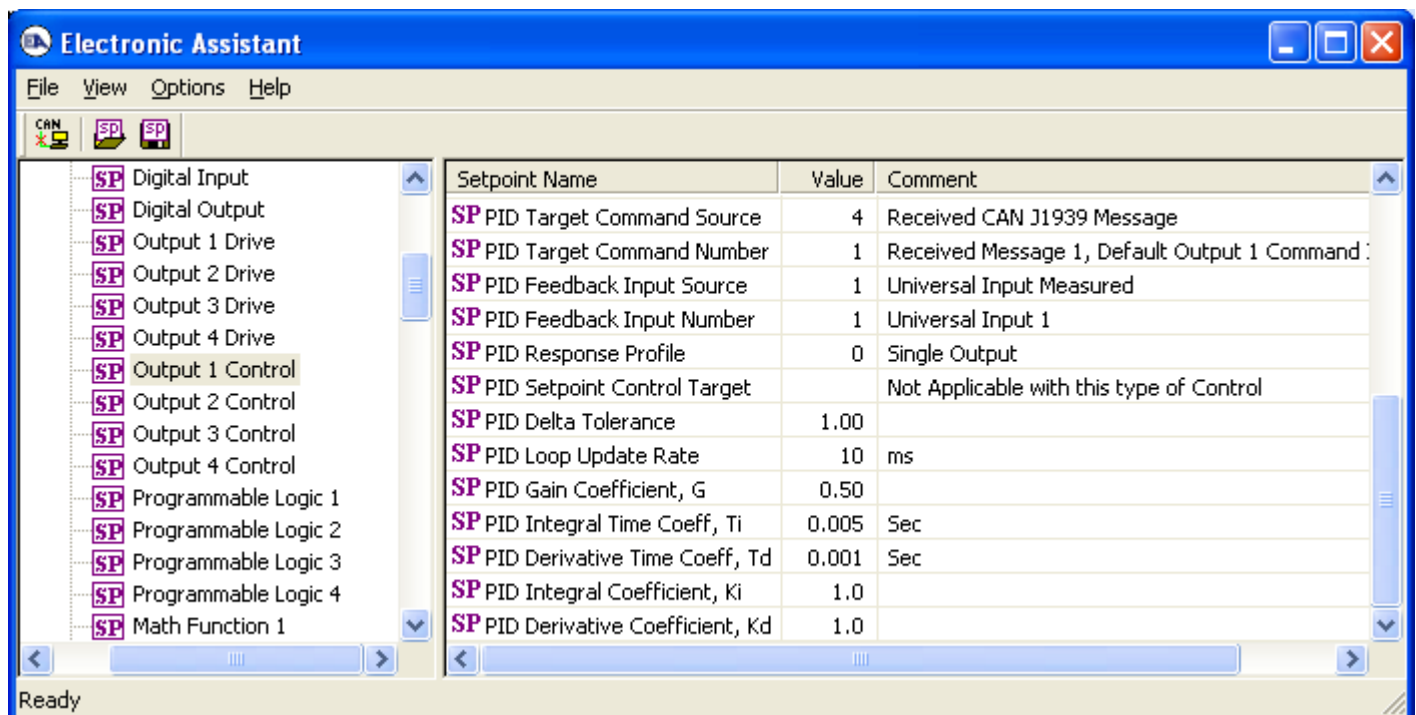

Screen Capture of Default Output 1 PID Setpoints with PID selected as Control Source

4.8. Programmable Logic Setpoints

The Programmable Logic function block is defined in Section 1.6. Please refer there for detailed information about how all these setpoints are used.

As this function block is disabled by default, there is nothing further to define in terms of defaults and ranges beyond that which is described in Section 1.6. The screen capture below shows how the setpoints referenced in that section appear on EA.

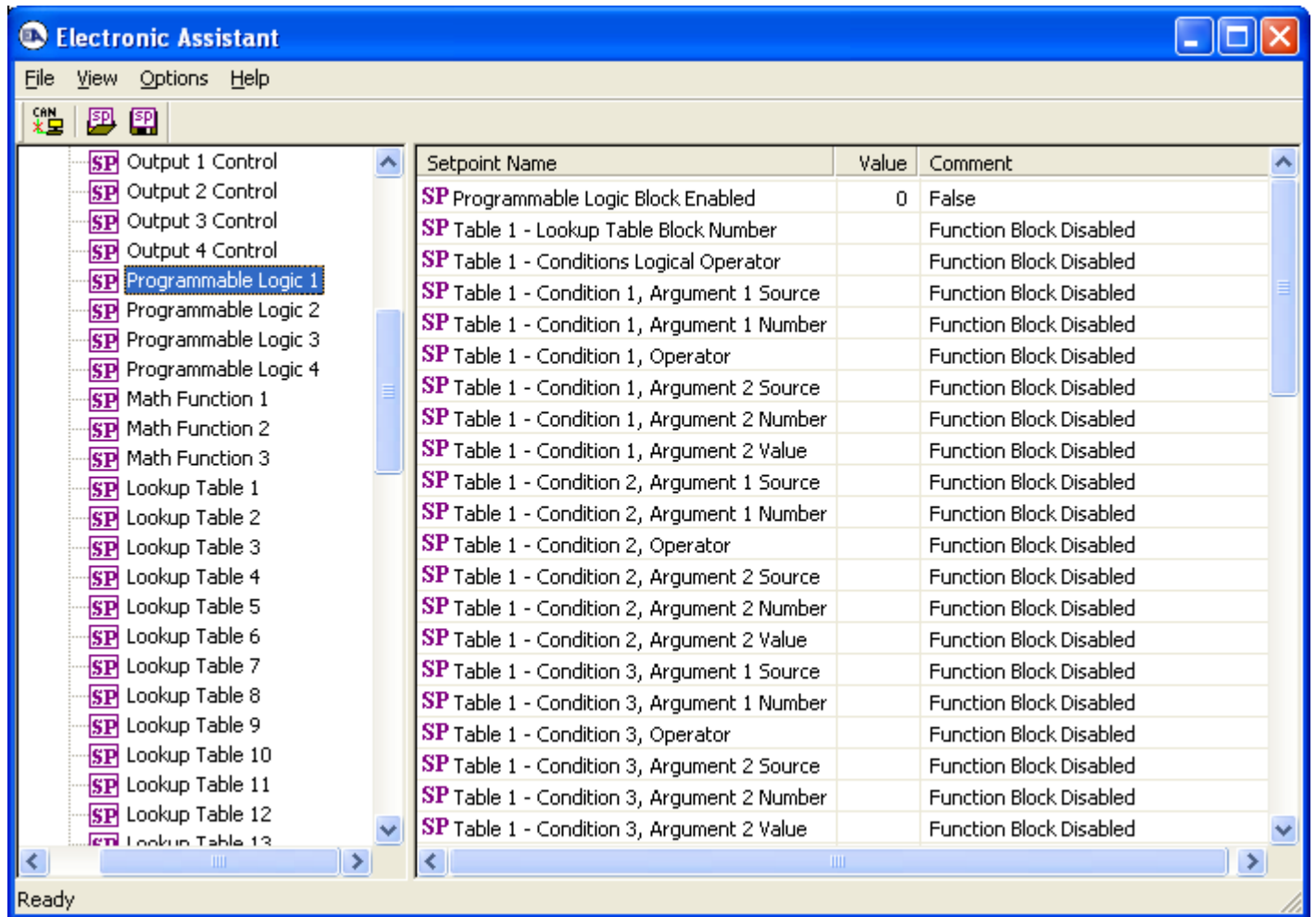

Setpoint Name	Value	Comment
SP Programmable Logic Block Enabled	0	False
SP Table 1 - Lookup Table Block Number		Function Block Disabled
SP Table 1 - Conditions Logical Operator		Function Block Disabled
SP Table 1 - Condition 1, Argument 1 Source		Function Block Disabled
SP Table 1 - Condition 1, Argument 1 Number		Function Block Disabled
SP Table 1 - Condition 1, Operator		Function Block Disabled
SP Table 1 - Condition 1, Argument 2 Source		Function Block Disabled
SP Table 1 - Condition 1, Argument 2 Number		Function Block Disabled
SP Table 1 - Condition 1, Argument 2 Value		Function Block Disabled
SP Table 1 - Condition 2, Argument 1 Source		Function Block Disabled
SP Table 1 - Condition 2, Argument 1 Number		Function Block Disabled
SP Table 1 - Condition 2, Operator		Function Block Disabled
SP Table 1 - Condition 2, Argument 2 Source		Function Block Disabled
SP Table 1 - Condition 2, Argument 2 Number		Function Block Disabled
SP Table 1 - Condition 2, Argument 2 Value		Function Block Disabled
SP Table 1 - Condition 3, Argument 1 Source		Function Block Disabled
SP Table 1 - Condition 3, Argument 1 Number		Function Block Disabled
SP Table 1 - Condition 3, Operator		Function Block Disabled
SP Table 1 - Condition 3, Argument 2 Source		Function Block Disabled
SP Table 1 - Condition 3, Argument 2 Number		Function Block Disabled
SP Table 1 - Condition 3, Argument 2 Value		Function Block Disabled

Screen Capture of Default Programmable Logic 1 Setpoints

4.9. Math Function Setpoints

The Math Function block is defined in Section 1.8. Please refer there for detailed information about how all these setpoints are used.

As this function block is disabled by default, the screen capture below has been configured to show how it would look when being used for the example given in Section 1.8.

Setpoint Name	Value	Comment
SP Programmable Logic 1		
SP Programmable Logic 2		
SP Programmable Logic 3		
SP Programmable Logic 4		
SP Math Function 1		
SP Math Function 2		
SP Math Function 3		
SP Lookup Table 1		
SP Lookup Table 2		
SP Lookup Table 3		
SP Lookup Table 4		
SP Lookup Table 5		
SP Lookup Table 6		
SP Lookup Table 7		
SP Lookup Table 8		
SP Lookup Table 9		
SP Lookup Table 10		
SP Lookup Table 11		
SP Lookup Table 12		
SP Lookup Table 13		
SP Lookup Table 14		
SP Lookup Table 15		
SP Lookup Table 16		
SP Power Supply Diag		
SP Lost Communication Diag		
SP DTC React		
SP CAN Transmit 1		
SP CAN Transmit 2		
SP CAN Transmit 3		
SP CAN Transmit 4		
SP CAN Transmit 5		
SP CAN Transmit 6		
SP Math Function Enabled	1	True
SP Math Input 1 Source	1	Universal Input Measured
SP Math Input 1 Number	1	Universal Input 1
SP Math Input 1 Minimum	0.000	
SP Math Input 1 Maximum	5.000	
SP Math Input 1 Scaler	0.75	
SP Math Input 1 Constant		Not Applicable with this type of Control
SP Math Input 2 Source	1	Universal Input Measured
SP Math Input 2 Number	2	Universal Input 2
SP Math Input 2 Minimum	0.000	
SP Math Input 2 Maximum	5.000	
SP Math Input 2 Scaler	0.25	
SP Math Input 2 Constant		Not Applicable with this type of Control
SP Math Function 1 (In1,In2)	9	+, Result = InA plus InB
SP Math Input 3 Source	0	Control Source Not Used
SP Math Input 3 Number		Not Applicable with this type of Control
SP Math Input 3 Minimum		No Control Source, Function Block Disabled
SP Math Input 3 Maximum		No Control Source, Function Block Disabled
SP Math Input 3 Scaler		No Control Source, Function Block Disabled
SP Math Input 3 Constant		No Control Source, Function Block Disabled
SP Math Function 2 (Func1,In3)		No Control Source, Function Block Disabled
SP Math Input 4 Source	0	Control Source Not Used
SP Math Input 4 Number		Not Applicable with this type of Control
SP Math Input 4 Minimum		No Control Source, Function Block Disabled
SP Math Input 4 Maximum		No Control Source, Function Block Disabled
SP Math Input 4 Scaler		No Control Source, Function Block Disabled
SP Math Input 4 Constant		No Control Source, Function Block Disabled
SP Math Function 3 (Func2,In4)		No Control Source, Function Block Disabled
SP Math Output Minimum Range	0.000	
SP Math Output Maximum Range	5.000	

Screen Capture of Example Math Function 1 Setpoints

Name	Range	Default	Notes
Math Function Enabled	Drop List	0, False	True or False
Math Input X Source (X = 1 to 4)	Drop List	0, Control Source Not Used	See Table 25
Math Input X Number	Per Source	0	See Table 25
Math Input X Minimum	-1,000,000 to 1,000,000	0.0	Converts Input into a Percentage before using it in the calculation.
Math Input X Maximum	-1,000,000 to 1,000,000	100.0	
Math Input X Scaler	-1.00 to 1.00	1.00	See Section 1.8
Math Input X Constant	-1,000,000 to 1,000,000	1.000	Only used when Input Source is set to "Control Constant"
Math Output Minimum Range	-1,000,000 to 1,000,000	0.0	Converts calculation from a percentage value to the desired physical unit.
Math Output Maximum Range	-1,000,000 to 1,000,000	100.0	

4.10. Lookup Table Setpoints

The Programmable Logic function block is defined in Section 1.5. Please refer there for detailed information about how all these setpoints are used.

As this function block's defaults are defined by the "X-Axis Source" selected from Table 25 , there is nothing further to define in terms of defaults and ranges beyond that which is described in Section 1.5 The screen capture below shows how the setpoints referenced in that section appear on EA.

Setpoint Name	Value	Comment
SP X-Axis Source	1	Universal Input Measured
SP X-Axis Number	1	Universal Input 1
SP X-Axis Type	0	Data Response
SP Point 1 - Response	2	Jump To
SP Point 2 - Response	1	Ramp To
SP Point 3 - Response	1	Ramp To
SP Point 4 - Response	1	Ramp To
SP Point 5 - Response	1	Ramp To
SP Point 6 - Response	1	Ramp To
SP Point 7 - Response	1	Ramp To
SP Point 8 - Response	1	Ramp To
SP Point 9 - Response	1	Ramp To
SP Point 10 - Response	1	Ramp To
SP Point 0 - X Value	0.000	
SP Point 1 - X Value	0.500	
SP Point 2 - X Value	0.944	
SP Point 3 - X Value	1.389	
SP Point 4 - X Value	1.833	
SP Point 5 - X Value	2.278	
SP Point 6 - X Value	2.722	
SP Point 7 - X Value	3.167	
SP Point 8 - X Value	3.611	
SP Point 9 - X Value	4.056	
SP Point 10 - X Value	4.500	
SP Point 0 - Y Value	0.000	
SP Point 1 - Y Value	150.000	
SP Point 2 - Y Value	300.000	
SP Point 3 - Y Value	450.000	
SP Point 4 - Y Value	600.000	
SP Point 5 - Y Value	750.000	
SP Point 6 - Y Value	900.000	
SP Point 7 - Y Value	1050.000	
SP Point 8 - Y Value	1200.000	
SP Point 9 - Y Value	1350.000	
SP Point 10 - Y Value	1500.000	

Screen Capture of Default Lookup Table 1 Setpoints

4.11. [Additional] Diagnostic Setpoints

Here, the [Additional] diagnostics are Power Supply and Lost Communication

The Diagnostic function block is defined in Section 1.9. Please refer there for detailed information about how all these setpoints are used.

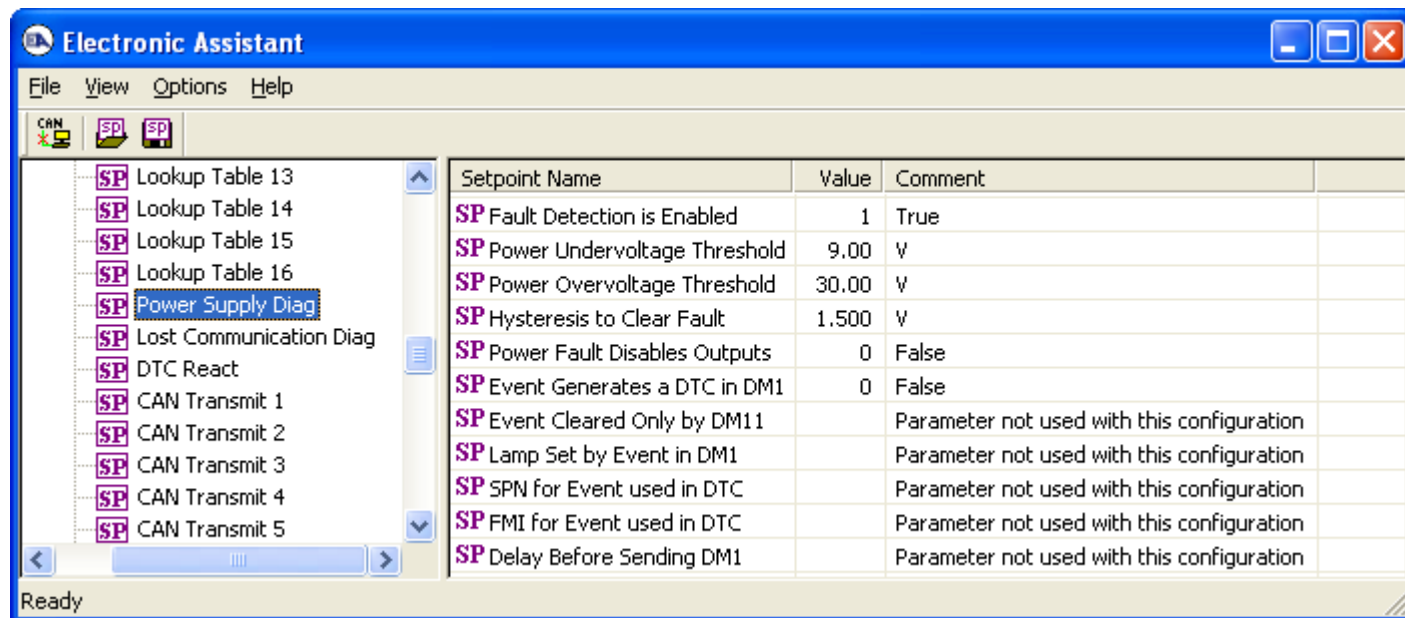

Screen Capture of Default Digital Output 1 Setpoints

Name	Range	Default	Notes
Fault Detection is Enabled	False or True	True	See Section 1.9
Power Undervoltage Threshold *	8 to Over V	9.00 V	
Power Overvoltage Threshold *	Under to 60V	30.00 V	
Hysteresis to Clear Fault	0.01 to 50.0	1.50 V N/A	Power Comm
Power Fault Disables Outputs *	False or True	False	
Event Generates a DTC in DM1	False or True	False	See Section 1.9
Event Cleared Only by DM11	False or True	False	See Section 1.9
Lamp Set by Event in DM1	Drop List	1, Amber, Warning 1, Amber, Warning	Power Comm
SPN for Event used in DTC	1 to 524287	520960 (\$7F300) 521216 (\$7F400)	Power Comm
FMI for Event used in DTC	Drop List	4, Voltage Below Normal 19, Received Data Error	Power Comm
Delay Before Sending DM1	0 to 60,000 ms	1000 ms	See Section 1.9

* Only used with Power Supply Diag group

4.12. DTC React Setpoints

The DTC React function block is defined in Section 1.10. Please refer there for detailed information about how all these setpoints are used.

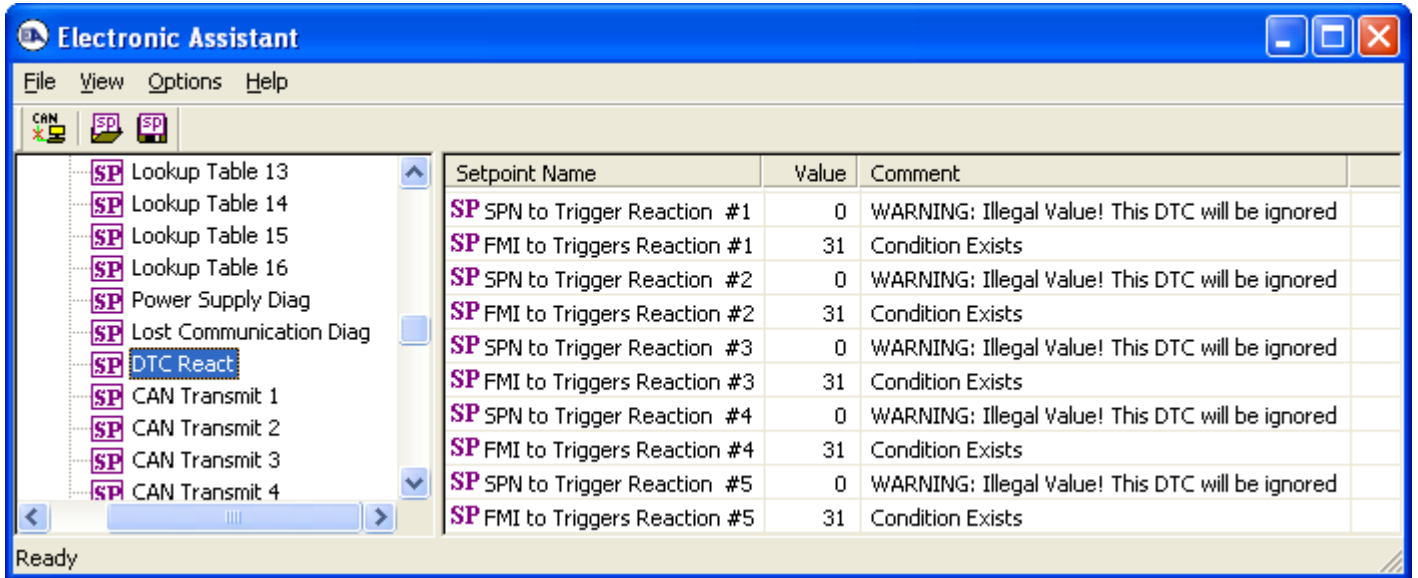

Screen Capture of Default DTC React Setpoints

Name	Range	Default	Notes
SPN to Trigger Reaction #X	0 to 524287	0	0 is an illegal value, and disables the DTC
FMI to Trigger Reaction #X	Drop List	31, Condition Exists	Supports all FMIs in the J1939 standard

Where X = 1 to 5

4.13. CAN Transmit Setpoints

The CAN Transmit function block is defined in Section 1.11, with additional information in Section 3.3. Please refer there for detailed information about how all these setpoints are used.

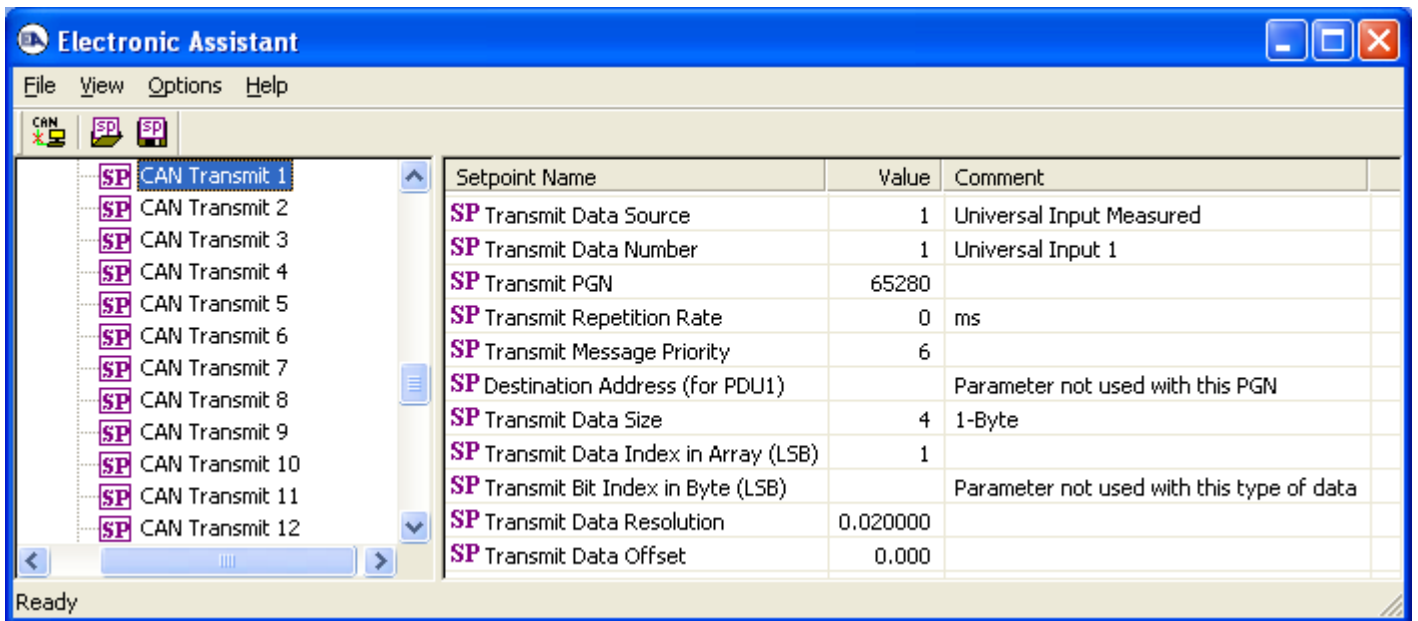

Screen Capture of Default CAN Transmit 1 Setpoints

Name	Range	Default	Notes
Transmit Data Source	Drop List	Different for each	See Table 22 for defaults
Transmit Data Number	Per Source	Different for each	See Table 22 for defaults
Transmit PGN	0 to 65535	Different for each	See Section 3.3 for defaults
Transmit Repetition Rate	0 to 60,000 ms	0	0ms disables transmit
Transmit Message Priority	0 to 7	6	Proprietary B Priority
Destination Address (for PDU1)	0 to 255	254 (0xFE, Null Address)	Not used by default
Transmit Data Size	Drop List	Different for each	0 = Not Used (disabled) 1 = 1-Bit 2 = 2-Bits 3 = 4-Bits 4 = 1-Byte 5 = 2-Bytes 6 = 4-Bytes See Section 3.3 for defaults
Transmit Data Index in Array (LSB)	1 to 8-DataSize	Different for each	See Section 3.3 for defaults
Transmit Bit Index in Byte (LSB)	1 to 8-BitSize	Different for each	Only used with Bit Data Types
Transmit Data Resolution	-1,000,000 to 1,000,000	Different for each	See Section 3.3 for defaults
Transmit Data Offset	-10,000 to 10,000	Different for each	See Section 3.3 for defaults



Recall that when multiple messages are sent on the same PGN, only the LOWEST Indexed channel's 'Repetition Rate' will be used. This means that even if a non-zero value is selected on a higher channel, but the lowest is still 0, no message will be sent.

4.14. CAN Receive Setpoints

The CAN Receive function block is defined in Section 1.12, with additional information in Section 3.4. Please refer there for detailed information about how all these setpoints are used.

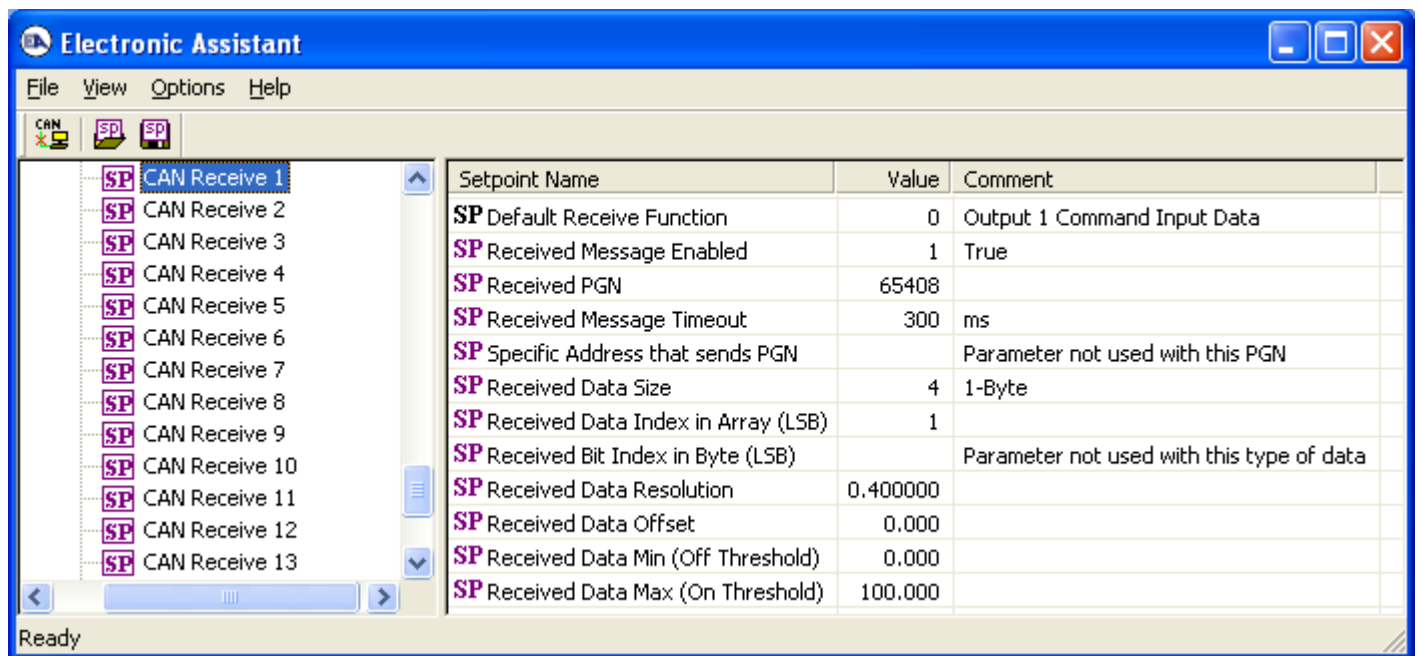

Screen Capture of Default CAN Receive 1 Setpoints

Note: By default, the “Received Message Enabled” is actually False, but it was changed to get the screen capture. Otherwise, all setpoints read “No Control Source, Function Block Disabled”

Name	Range	Default	Notes
Default Receive Function	Drop List	Different for each	Read-Only Setpoint See Table 23 for defaults
Received Message Enabled	False or True	False	See note above
Received PGN	0 to 65535	Different for each	See Section 3.4 for defaults
Received Message Timeout	0 to 60,000 ms	300 ms	Expects all data at 100ms
Specific Address that sends PGN	0 to 255	254 (0xFE, Null Addr)	Not used by default
Receive Data Size	Drop List	Different for each	0 = Not Used (disabled) 1 = 1-Bit 2 = 2-Bits 3 = 4-Bits 4 = 1-Byte 5 = 2-Bytes 6 = 4-Bytes See Section 3.4 for defaults
Receive Data Index in Array (LSB)	1 to 9-DataSize	Different for each	See Section 3.4 for defaults
Receive Bit Index in Byte (LSB)	1 to 9-BitSize	Different for each	Only used with Bit Data Types
Receive Data Resolution	-1,000,000 to 1,000,000	Different for each	See Section 3.4 for defaults
Receive Data Offset	-10,000 to 10,000	Different for each	See Section 3.4 for defaults
Received Data Min (Off Threshold)	-1,000,000 to Max	0.0	See Section 3.4 for defaults
Received Data Max (On Threshold)	Min to 1,000,000	100.0	See Section 3.4 for defaults

5. USING RS-232 WITH TERA TERM

Additional information for diagnostics or testing is available through RS-232. To use this feature, setup per the following steps. The RS-232 header is only available inside the unit which will have to be opened.

- Connect the DB-9 to a COM port on a PC or laptop. Use the following RS-232 connection.

J1 Header on Board		DB-9 Female	
Pin #	Controller Function	Pin #	PC Function
1	RS-232 Transmit	2	RS-232 Receive
2	RS-232 Receive	3	RS-232 Transmit
3	GND Reference	5	RS-232 GND

- Open Tera Term Pro, and set it up as shown in the steps below.
(Free and downloadable from <http://en.sourceforge.jp/projects/ttssh2/releases/>)
- Select **Serial** with the appropriate COM port for your PC or laptop

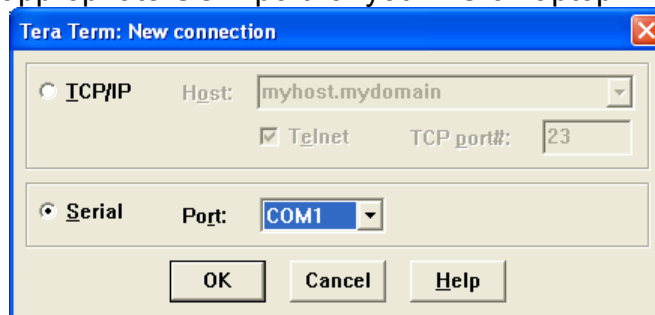

- Go to **Setup/Serial Port** and change the settings to exactly as shown below (other than Port)

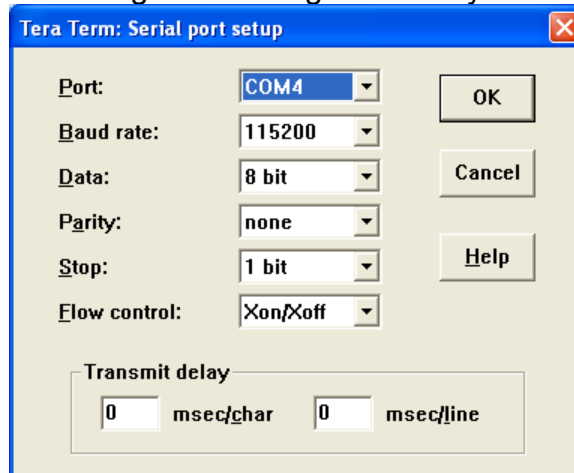

- Go to **Setup/Terminal** and verify that New-line Transmit and Receive are CR. The window size can be adjusted as desired by checking 'Term size = win size'

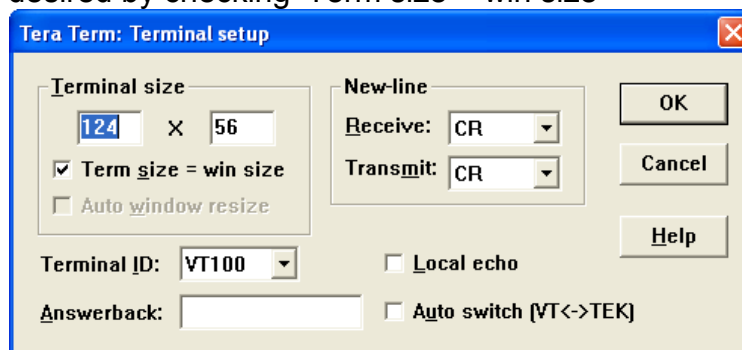

5.1. Main Menu Options

Apply power to the 8i5o Valve Controller, and the power up banner will be displayed.

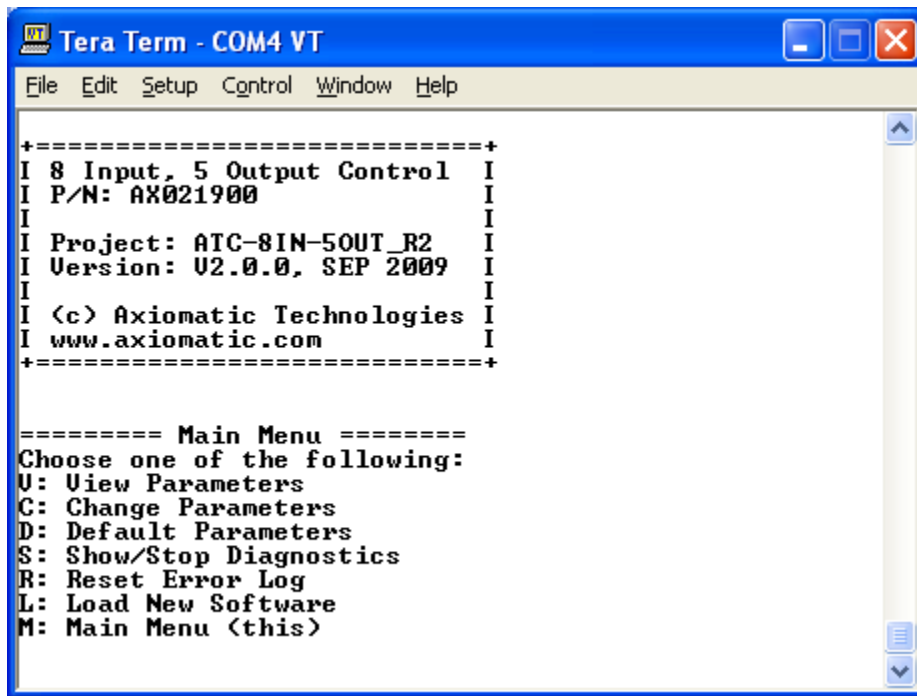

```
Tera Term - COM4 VT
File Edit Setup Control Window Help
+-----+
I 8 Input, 5 Output Control I
I P/N: AX021900 I
I I
I Project: ATC-8IN-5OUT_R2 I
I Version: V2.0.0, SEP 2009 I
I I
I <c> Axiomatic Technologies I
I www.axiomatic.com I
+-----+

===== Main Menu =====
Choose one of the following:
U: View Parameters
C: Change Parameters
D: Default Parameters
S: Show/Stop Diagnostics
R: Reset Error Log
L: Load New Software
M: Main Menu <this>
```

The “View Parameters” option ‘v’ allows the user to see the same information as available through the Electronic Assistant. However, changing the setpoints is not possible via RS-232, so the CAN link must be used.

The first example below illustrates how the View menus work. The first prompt asks for the group to be displayed, the second the specific function block to be shown.

Please note, due to character space limitations, the names of the various setpoints are abridged, and do not match exactly those used by the EA, as described in Section 4. However, they should be close enough as to not cause confusion as to each RS-232 Name’s function.

```

Tera Term - COM4 VT
File Edit Setup Control Window Help
v
0: View All Groups
2: Miscellaneous
3: Transmit Msgs
4: Receive Msgs
5: Input Measuring
6: Output Drive
7: Output Control
8: Lamp Control
9: Extra Diags
10: PID Control
11: Lookup Tables
12: Logic Blocks
Enter channel to view: 7

0: View All Groups
1: Universal Output 1
2: Universal Output 2
3: Universal Output 3
4: Universal Output 4
Enter channel to view: 1

=====
Universal Output 1
=====

CommandInput
-----
Control_Source = LookupTable
Control_Number = 1

```

The “View All Groups” option ‘0’ will cycle through all the view menus. After a function block is displayed, the unit will prompt “Continue?” To see the next block, hit ‘y’, to exit the loop and return to the main menu, hit ‘x’. After all the data has been displayed, hit ‘m’ to show the main menu.

```

0: View All Groups
2: Miscellaneous
3: Transmit Msgs
4: Receive Msgs
5: Input Measuring
6: Output Drive
7: Output Control
8: Lamp Control
9: Extra Diags
10: PID Control
11: Lookup Tables
12: Logic Blocks
Enter channel to view: 0

Application = I/O Controller
ADCFilterFreq = 60Hz

ArbAddrCapable = TRUE
IndustryGroup = 0
VehicleSysInst = 0
VehicleSystem = 0
Function = 66
FunctionInst = 17
ECUInstance = 0
ManufactCode = 162
IDNumber = 958502 = 0X000EA026

J1939_Address = 128 = 0X80
CANBaudRate = 250
Continue? y

```

The “Default Parameters” option ‘d’ resets all setpoints to the factory defaults as described in Section 4. The unit will prompt for confirmation that this action should proceed, and enter ‘y’ to continue.

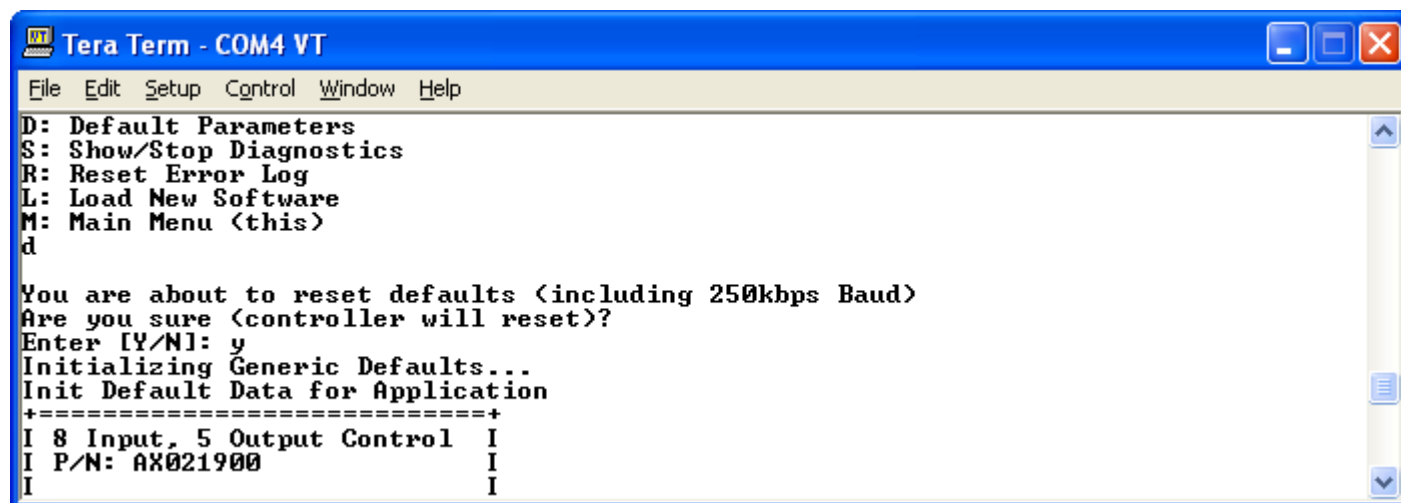

```
Tera Term - COM4 VT
File Edit Setup Control Window Help
D: Default Parameters
S: Show/Stop Diagnostics
R: Reset Error Log
L: Load New Software
M: Main Menu <this>
d

You are about to reset defaults <including 250kbps Baud>
Are you sure <controller will reset>?
Enter [Y/N]: y
Initializing Generic Defaults...
Init Default Data for Application
+-----+
I 8 Input, 5 Output Control I
I P/N: AX021900 I
I I
```

The “Reset Error Log” option ‘r’ will reset all occurrence counts in the diagnostic log to zero.

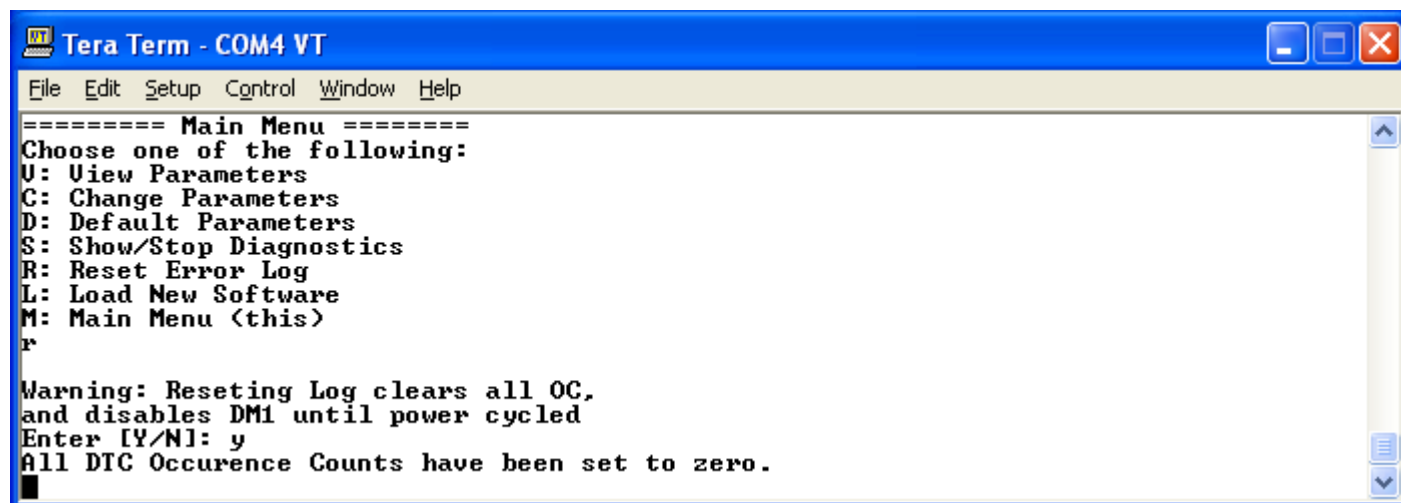

```
Tera Term - COM4 VT
File Edit Setup Control Window Help
===== Main Menu =====
Choose one of the following:
U: View Parameters
C: Change Parameters
D: Default Parameters
S: Show/Stop Diagnostics
R: Reset Error Log
L: Load New Software
M: Main Menu <this>
r

Warning: Resetting Log clears all OC,
and disables DM1 until power cycled
Enter [Y/N]: y
All DTC Occurrence Counts have been set to zero.
█
```

The “Show Diagnostics” option ‘s’ is described in section 5.2

The “Change Baud Rate” option ‘c’ is described in section 5.3

The “Load New Software” option ‘l’ is described in section 5.4

5.2. Additional Debug Information

The “Show Diagnostics” option ‘s’ will display something like the following screen capture

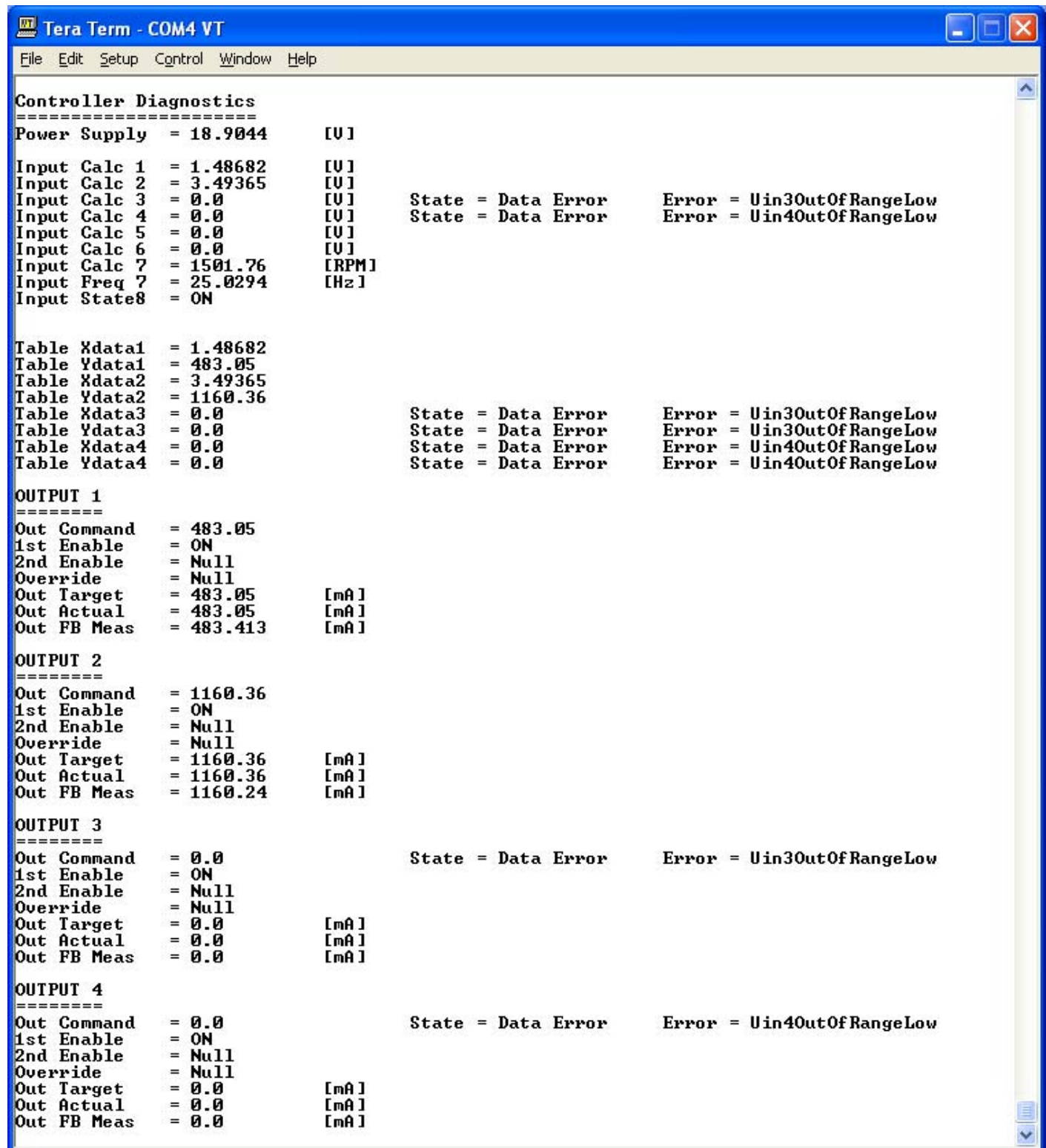

```
Tera Term - COM4 VT
File Edit Setup Control Window Help

Controller Diagnostics
=====
Power Supply = 18.9044 [V]

Input Calc 1 = 1.48682 [V]
Input Calc 2 = 3.49365 [V]
Input Calc 3 = 0.0 [V] State = Data Error Error = Uin3OutOfRangeLow
Input Calc 4 = 0.0 [V] State = Data Error Error = Uin4OutOfRangeLow
Input Calc 5 = 0.0 [V]
Input Calc 6 = 0.0 [V]
Input Calc 7 = 1501.76 [RPM]
Input Freq 7 = 25.0294 [Hz]
Input State8 = ON

Table Xdata1 = 1.48682
Table Ydata1 = 483.05
Table Xdata2 = 3.49365
Table Ydata2 = 1160.36
Table Xdata3 = 0.0 State = Data Error Error = Uin3OutOfRangeLow
Table Ydata3 = 0.0 State = Data Error Error = Uin3OutOfRangeLow
Table Xdata4 = 0.0 State = Data Error Error = Uin4OutOfRangeLow
Table Ydata4 = 0.0 State = Data Error Error = Uin4OutOfRangeLow

OUTPUT 1
=====
Out Command = 483.05
1st Enable = ON
2nd Enable = Null
Override = Null
Out Target = 483.05 [mA]
Out Actual = 483.05 [mA]
Out FB Meas = 483.413 [mA]

OUTPUT 2
=====
Out Command = 1160.36
1st Enable = ON
2nd Enable = Null
Override = Null
Out Target = 1160.36 [mA]
Out Actual = 1160.36 [mA]
Out FB Meas = 1160.24 [mA]

OUTPUT 3
=====
Out Command = 0.0 State = Data Error Error = Uin3OutOfRangeLow
1st Enable = ON
2nd Enable = Null
Override = Null
Out Target = 0.0 [mA]
Out Actual = 0.0 [mA]
Out FB Meas = 0.0 [mA]

OUTPUT 4
=====
Out Command = 0.0 State = Data Error Error = Uin4OutOfRangeLow
1st Enable = ON
2nd Enable = Null
Override = Null
Out Target = 0.0 [mA]
Out Actual = 0.0 [mA]
Out FB Meas = 0.0 [mA]
```

If an input or feedback value is in an error state, it will be indicated on the diagnostics screen, as shown by inputs 3 and 4 in the previous screen capture. In this case, no voltage sources were connected to input 3 thru 6, but because error detection is disabled on inputs 5 and 6, the 0V does not flag an error.

Notice also how the error state of the inputs is reflected in the X and Y-Axis data for tables 3 and 4, and again as the command for outputs 3 and 4.

However, for outputs 1 and 2, the command data matches that of the Y-Axis table from the respective tables. Since the Y-Axis range and the output data ranges match, the output target has a 1:1 relationship with the command data, and so the value is mirrored once again at the coil drive.

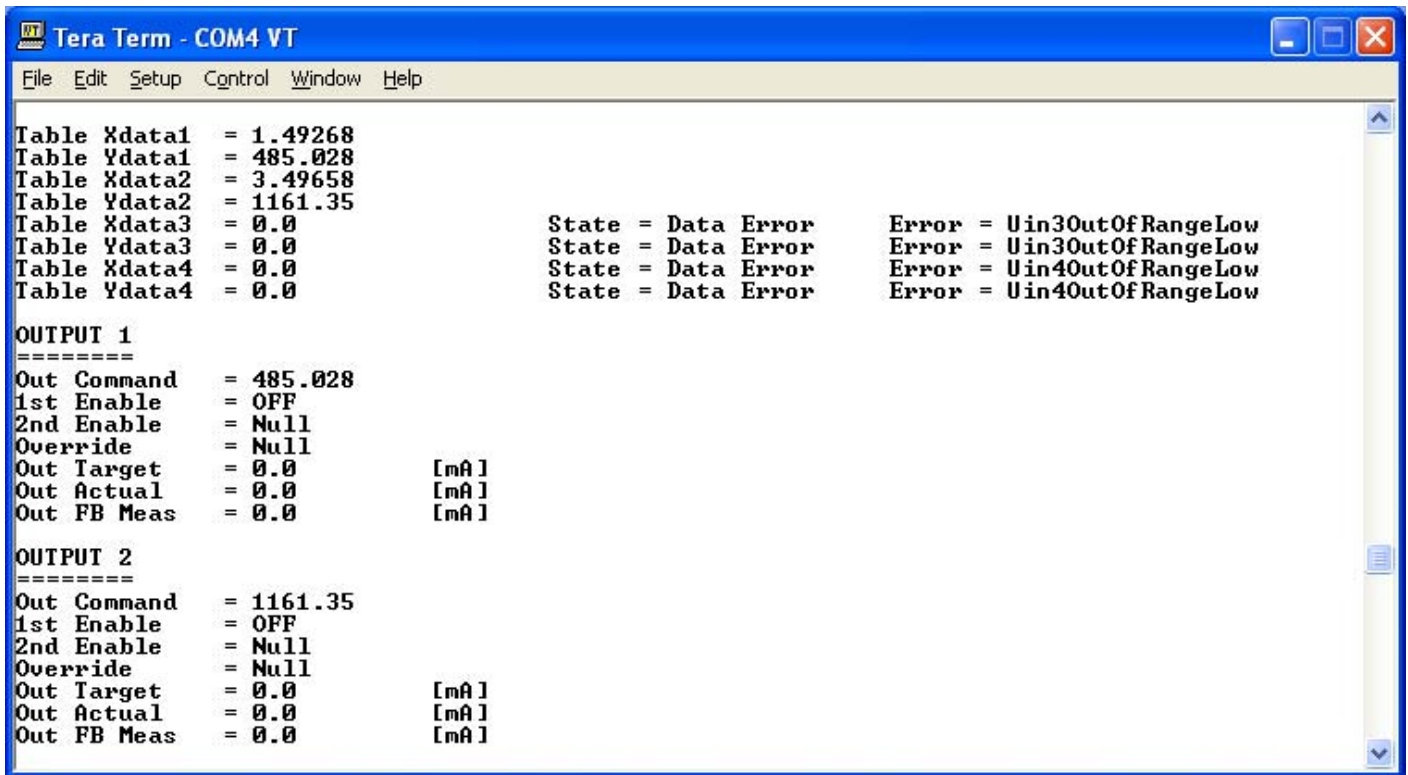

In this screen capture, it shows how even though the command data for Outputs 1 and 2 is still present, the outputs are both at 0.0mA because the first Enable input (Digital Input 8 by default) was turned OFF.

5.3. Changing CAN Baud Rate

By default, the controller uses the J1939 standard CAN baud rate of 250 kbps. The Electronic Assistant[®]  only supports this Baud, so configuring the unit is only possible at 250 kbps.

Although it is not compliant with the J1939 standard, once the unit has been configured per the application requirements, the user does have the option to change the CAN Baud Rate via RS-232. This option should be used with caution, however, only once satisfied that the setpoints are all at the desired values.

Before doing this, it is highly recommended to disconnect the unit from any CAN network, as it will put the bus into an error passive mode either before or after the baud rate is changed. Once it has changed (per the screen capture below), the 8i5o Valve Controller can be re-connected to a CAN network running at the new baud.

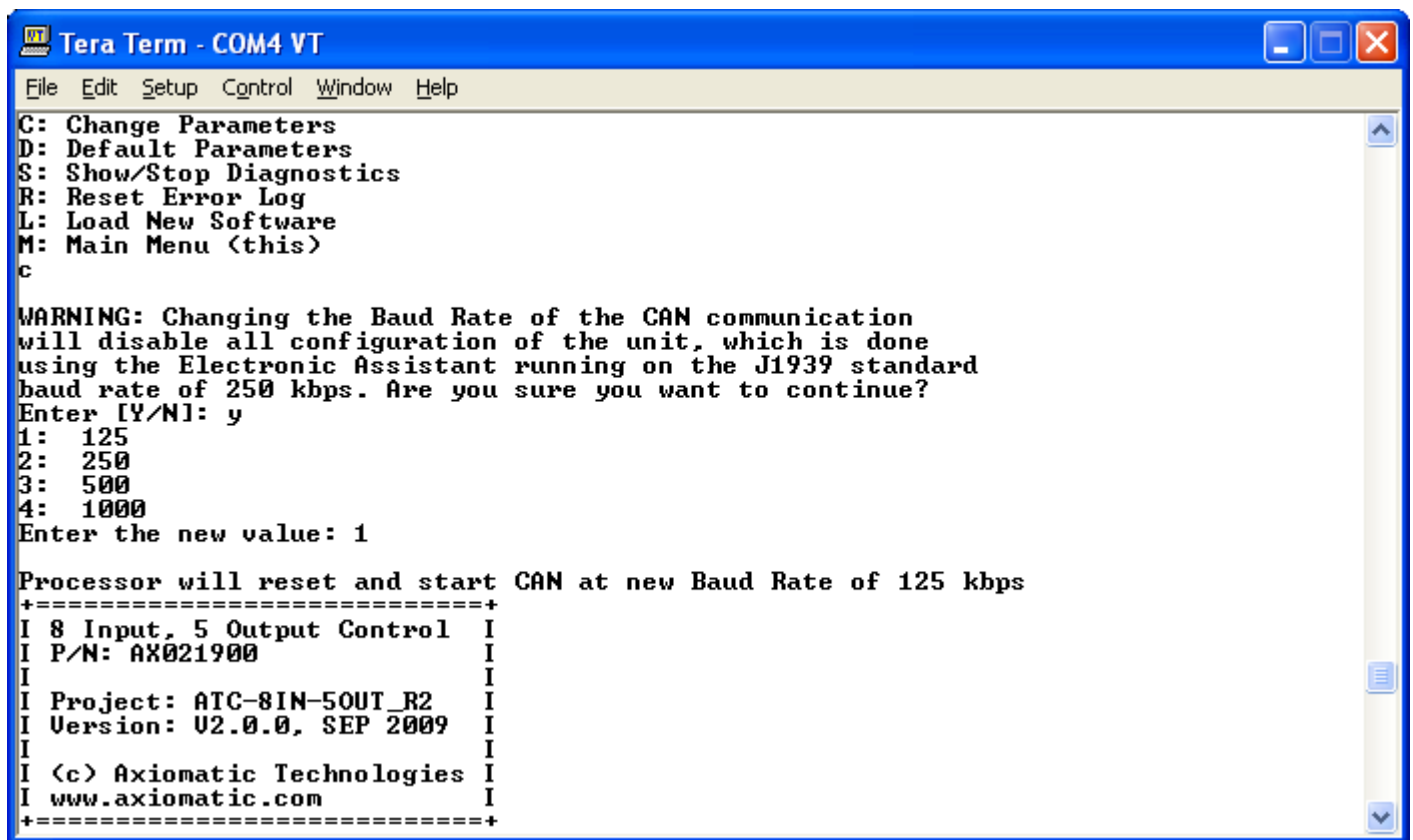

```
Tera Term - COM4 VT
File Edit Setup Control Window Help
C: Change Parameters
D: Default Parameters
S: Show/Stop Diagnostics
R: Reset Error Log
L: Load New Software
M: Main Menu <this>
c
WARNING: Changing the Baud Rate of the CAN communication
will disable all configuration of the unit, which is done
using the Electronic Assistant running on the J1939 standard
baud rate of 250 kbps. Are you sure you want to continue?
Enter [Y/N]: y
1: 125
2: 250
3: 500
4: 1000
Enter the new value: 1
Processor will reset and start CAN at new Baud Rate of 125 kbps
+-----+
I 8 Input, 5 Output Control I
I P/N: AX021900 I
I I I
I Project: ATC-8IN-5OUT_R2 I
I Version: V2.0.0, SEP 2009 I
I I I
I <c> Axiomatic Technologies I
I www.axiomatic.com I
+-----+
```

APPENDIX A – Diagnostic Trouble Codes Table

J1939/73 DM1/2		Description	Detection conditions	Associated Setpoint Group	Restricted Function
SPN ¹ /FMI	Lamp ¹				
520192-04	Amber	Universal Input 1 Minimum Error	Measured Input < Minimum Error	Universal Input 1	Note 2
520192-03	Amber	Universal Input 1 Maximum Error	Measured Input > Maximum Error	Universal Input 1	Note 2
520193-04	Amber	Universal Input 2 Minimum Error	Measured Input < Minimum Error	Universal Input 2	Note 2
520193-03	Amber	Universal Input 2 Maximum Error	Measured Input > Maximum Error	Universal Input 2	Note 2
520194-04	Amber	Universal Input 3 Minimum Error	Measured Input < Minimum Error	Universal Input 3	Note 2
520194-03	Amber	Universal Input 3 Maximum Error	Measured Input > Maximum Error	Universal Input 3	Note 2
520195-04	Amber	Universal Input 4 Minimum Error	Measured Input < Minimum Error	Universal Input 4	Note 2
520195-03	Amber	Universal Input 4 Maximum Error	Measured Input > Maximum Error	Universal Input 4	Note 2
520196-04	Amber	Universal Input 5 Minimum Error	Measured Input < Minimum Error	Universal Input 5	Note 2
520196-03	Amber	Universal Input 5 Maximum Error	Measured Input > Maximum Error	Universal Input 5	Note 2
520197-04	Amber	Universal Input 6 Minimum Error	Measured Input < Minimum Error	Universal Input 6	Note 2
520197-03	Amber	Universal Input 6 Maximum Error	Measured Input > Maximum Error	Universal Input 6	Note 2
520198-18	Amber	Magnetic Pickup Minimum Error	Measured Input < Minimum Error	Magnetic Pickup	Note 2
520198-16	Amber	Magnetic Pickup Maximum Error	Measured Input > Maximum Error	Magnetic Pickup	Note 2
520448-05	Amber	Output 1 Current Open Circuit	Output 1 Current FB < 50mA (when ON)	Output 1 Drive	None
520448-06	Amber	Output 1 Current Short Circuit (Software)	Output 1 Current FB > 2750mA	Output 1 Drive	Out 1 Off
520449-05	Amber	Output 2 Current Open Circuit	Output 2 Current FB < 50mA (when ON)	Output 2 Drive	None
520449-06	Amber	Output 2 Current Short Circuit (Software)	Output 2 Current FB > 2750mA	Output 2 Drive	Out 2 Off
520450-05	Amber	Output 3 Current Open Circuit	Output 1 Current FB < 50mA (when ON)	Output 3 Drive	None
520450-06	Amber	Output 3 Current Short Circuit (Software)	Output 1 Current FB > 2750mA	Output 3 Drive	Out 3 Off
520451-05	Amber	Output 4 Current Open Circuit	Output 2 Current FB < 50mA (when ON)	Output 4 Drive	None
520451-06	Amber	Output 4 Current Short Circuit (Software)	Output 2 Current FB > 2750mA	Output 4 Drive	Out 4 Off
520704-31	Amber	Digital Output Fault	Hardware sends a fault signal to the processor	Digital Output	None
520960-04	Amber	Power Supply Under Voltage	Measured Power Supply < Power Undervoltage Threshold	Power Supply Diag	Outs Off
520960-03	Amber	Power Supply Over Voltage	Measured Power Supply > Power Overvoltage Threshold	Power Supply Diag	Outs Off
521216-19	Amber	Lost Communication	Did not receive an expected CAN message within timeout period	CAN Receive X	Out Off

Note 1: SPN, FMI and Lamp Type are user configurable parameters for all DTC. Default values are shown in this table

Note 2: An input used as a control or feedback input for an output control block will disable the corresponding output when it is in an error state

Note 3: All diagnostic trouble code (DTC) can be disabled at any time by setting the "XXX Fault Generates DTCs" to FALSE.

If this setpoint for all diagnostics are FALSE, the DM1 message will not be sent every 1 second (i.e. in a standalone 8i5o mode where no CAN is connected)

APPENDIX B – Technical Specifications

Input Specifications

Power Supply Input - Nominal	12V or 24Vdc nominal 9...60 Vdc
Reverse Polarity Protection	Provided
Surge Protection	Provided (up to 75V)
Under-voltage Protection	Provided (software, hardware shutdown at 7.5V)
Over-voltage Protection	Provided (software)
Universal Inputs	<p>Six fully independent inputs selectable as : Voltage; Current; Resistive; Frequency; RPM; PWM; or Digital types</p> <p>12-bit Analog to Digital (voltage, current, resistive) 15-bit Timer (frequency, RPM, PWM)</p> <p>Inputs are sampled every 1 msec. Protected against shorts to GND or +Vcc</p> <p>Voltage Types: 1mV resolution, accuracy +/- 1% error 0-1V or 0-2.5V have 1MΩ Impedance 0-5V has 150 kΩ Impedance 0-10V has 133 kΩ Impedance</p> <p>Current Types: 1μA resolution, accuracy +/- 2% error Current sense resistor 124Ω</p> <p>Resistive Input: 1Ω resolution, accuracy +/- 1% error Self-calibrating for range of 30 Ω to 250 kΩ</p> <p>Frequency Input: accuracy +/- 1% error 1MΩ Impedance 0.5 to 50Hz Range: 0.01Hz resolution 10Hz to 1kHz Range: 0.1Hz resolution 100 Hz to 10kHz Range: 1Hz resolution</p> <p>PWM Input: 0.01% resolution, accuracy +/- 1% error 1MΩ Impedance</p> <p>Digital Input: 1MΩ Impedance, Active High Debouncing provided at 1ms resolution</p>
Magnetic Pickup Input	One input, sampled as per Section 1.1 Range: 0.5 Hz to 10 kHz 100mV to 100V RMS
Digital Input	One Active High or Active Low Input Configurable 10kΩ pullup or pulldown resistor Debouncing provided at 1ms resolution
Analog Reference	Three Provided

Output Specifications

Universal Outputs	<p>Four fully independent software controlled outputs selectable as: Proportional Current; Hotshot Digital; PWM Duty Cycle; Proportional Voltage; or On/Off Digital types</p> <p>Half-bridge outputs, current sensing, grounded load. High side sourcing up to 2.5A</p> <p>Current Outputs: 1mA resolution, accuracy +/- 2% error Software controlled PID current, not accessible to user Fully configurable dither from 50 to 400Hz. High frequency drive at 25kHz</p> <p>Voltage Outputs: 0.1V resolution, accuracy +/- 5% error Average output based on unit power supply High frequency drive at 25kHz</p> <p>PWM Outputs: 0.1% resolution, accuracy +/- 0.1% error Configurable frequency ONLY if no voltage or current output types are used.</p> <p>Digital On/Off: Load at supply voltage must not draw more than 2.5A.</p>
Digital Output	High side sourcing up to 2.5A, grounded load Can be used to drive a diagnostic lamp Works with inductive or resistive loads
Protection	Fully protected against short circuit to ground. Unit will fail safe in the case of a short-circuit condition, and is self-recovering when the short is removed.
Power Reference	Two Provided

General Specifications

Microprocessor	DSP56F8366	
Diagnostics	Each input and output channel can be configured to send diagnostic messages to the CAN network if the I/O goes out of range. Diagnostic data is stored in a non-volatile log. Refer to Section 1.9 for details	<p>Set up of SAE J1939 Controller on a CAN Network:</p>
Additional Fault Feedback	There are several types of faults that the controller will detect and provide a response: unit power supply undervoltage and overvoltage, and lost communication. They can be sent to the CAN bus.	
CAN User Interface	<p>Electronic Assistant® for <i>Windows</i> operating systems It comes with a royalty-free license for use.</p> <p>The Axiomatic Electronic Assistant requires an USB-CAN converter to link the device's CAN port to a <i>Windows</i>-based PC for initial configuration. An Axiomatic USB-CAN Converter AX070501 is available.</p> <p>Order the EA and USB-CAN as a kit (P/N AX070502), which includes all interconnecting cables.</p>	
RS-232	<p>1 RS-232 port interfaces to a serial port (i.e. COM1) on a PC (115200 Baud Rate, N81, Xon/Xoff Flow Control) Not available through the connector</p> <p>Connect the RS-232 port from the controller to a PC with Tera Term (Pro) freeware. The user can use the RS-232 port for diagnostics or testing. Changing setpoints is not possible through RS-232. The CAN port and the Axiomatic Electronic Assistant® must be used to configure the motor controller. For further details refer to Section 5.</p> <p>NB. Tera Term (Pro) is freeware and is downloadable from http://en.sourceforge.jp/projects/ttssh2/releases/.</p>	
Vibration and Shock Compliance	<p>MIL-STD-202G, Test 204D, 214A and 213B</p> <p>7.68 Grms (Random)</p> <p>10 g peak (Sine)</p> <p>50 g (Shock)</p>	
Electrical Connections	Refer to Section 2.2, Wires should be of the appropriate gauge to meet requirements of applicable electrical codes and suit the specifications of the connector(s).	
Packaging and Dimensions	IP67 rating for product assembly Refer to Figure 28 for dimensions.	
Operating Conditions	Operating: -40 to 85°C (-40 to 185°F)	
Weight	0.55 lb. (0.25 kg)	



OUR PRODUCTS

Battery Chargers
CAN bus Controls
Current Converters
DC/DC Power Converters
DC Voltage/Current Signal Converters
Engine Temperature Scanners
Fan Drive Controllers
CAN Gateways
Hydraulic Valve Controllers
I/O Controls
LVDT Simulators
Machine Control Systems
Motor Controls
PID Controls
Position Sensors, Angle Measurement Inclinometers
Power Supplies
PWM Signal Converters/Isolators
Resolver Signal Conditioners
Service Tools
Signal Conditioners
Strain Gauge CAN Controls
Surge Suppressors

OUR COMPANY

Axiomatic provides electronic machine controls, components, and systems to the off-highway, commercial vehicle, electric vehicle, military, power generator set, material handling and industrial OEM markets.

We provide efficient, innovative solutions that focus on adding value for our customers.

We emphasize service and partnership with our customers, suppliers, and employees to build long term relationships and mutual trust.

QUALITY DESIGN AND MANUFACTURING

Axiomatic is an ISO 9001:2008 registered facility.

SERVICE

All products to be returned to Axiomatic require a Return Materials Authorization Number (RMA#).

Please provide the following information when requesting an RMA number:

- Serial number, part number
- Axiomatic invoice number and date
- Hours of operation, description of problem
- Wiring set up diagram, application
- Other comments as needed

When preparing the return shipping paperwork, please note the following. The commercial invoice for customs (and packing slip) should state the harmonized international HS (tariff code), valuation and return goods terminology, as shown in italics below. The value of the units on the commercial invoice should be identical to their purchase price.

*Goods Made In Canada (or Finland)
Returned Goods for Warranty Evaluation, HS: 9813.00
Valuation Identical Goods
Axiomatic RMA#*

WARRANTY, APPLICATION APPROVALS/LIMITATIONS

Axiomatic Technologies Corporation reserves the right to make corrections, modifications, enhancements, improvements, and other changes to its products and services at any time and to discontinue any product or service without notice. Customers should obtain the latest relevant information before placing orders and should verify that such information is current and complete. Users should satisfy themselves that the product is suitable for use in the intended application. All our products carry a limited warranty against defects in material and workmanship. Please refer to our Warranty, Application Approvals/Limitations and Return Materials Process as described on www.axiomatic.com/service.html.

CONTACTS

Axiomatic Technologies Corporation
5915 Wallace Street
Mississauga, ON
CANADA L4Z 1Z8
TEL: +1 905 602 9270
FAX: +1 905 602 9279
www.axiomatic.com

Axiomatic Technologies Oy
Höytämöntie 6
33880 Lempäälä
FINLAND
TEL: +358 3 3595 600
FAX: +358 3 3595 660
www.axiomatic.fi