



USER MANUAL UMAX022001
Version 2

SINGLE UNIVERSAL INPUT, DUAL 3A OUTPUT VALVE CONTROLLER

With CANopen®

USER MANUAL

P/N: AX022001

In Europe:
Axiomatic Technologies Oy
Höytämöntie 6
33880 LEMPÄÄLÄ - Finland
Tel. +358 3 3595 600
Fax. +358 3 3595 660
www.axiomatic.fi

In North America:
Axiomatic Technologies Corporation
5915 Wallace Street
Mississauga, ON Canada L4Z 1Z8
Tel. 1 905 602 9270
Fax. 1 905 602 9279
www.axiomatic.com

VERSION HISTORY

Version	Date	Author	Modifications
1.0.0	October 29, 2010	Anna Murray	Initial Draft
1.1.0	January 27, 2011	Anna Murray	Updated object 1029h to be compliant with DS-404. Fixed some minor typos
1.1.1	January 31, 2013	A. Wilkins	Changed power supply input range per ECN12-0166.
1.1.2	June 23, 2015	A. Wilkins	Added CE marking.
2	November 4, 2016	Gustavo Del Valle	Updated <i>Dither Frequency Range</i>
-	November 7, 2016	A. Wilkins	Added updated dimensional drawing.

ACRONYMS

AI	Analog Input (Universal)
AO	Analog Output (Universal)
CAN	Controller Area Network
CANopen®	CANopen® is a registered community trademark of CAN in Automation e.V.
CAN-ID	CAN 11-bit Identifier
COB	Communication Object
CTRL	Control
DI	Digital Input
DO	Digital Output
EDS	Electronic Data Sheet
EMCY	Emergency
LSB	Least Significant Byte (or Bit)
LSS	Layer Settling Service
MSB	Most Significant Byte (or Bit)
NMT	Network Management
PID	Proportional-Integral-Derivative Control
RO	Read Only Object
RPDO	Received Process Data Object
RW	Read/Write Object
SDO	Service Data Object
TPDO	Transmitted Process Data Object
WO	Write Only Object

REFERENCES

[DS-301]	CiA DS-301 V4.1 – CANopen Application Layer and Communication Profile. CAN in Automation 2005
[DS-305]	CiA DS-305 V2.0 – Layer Setting Service (LSS) and Protocols. CAN in Automation 2006
[DS-404]	CiA DS-404 V1.2 – CANopen profile for Measurement Devices and Closed Loop Controllers. CAN in Automation 2002

These documents are available from the CAN in Automation e.V. website <http://www.can-cia.org/>.

TABLE OF CONTENTS

1. OVERVIEW OF CONTROLLER.....	9
1.1. Description of Single Input, Dual Output Controller.....	9
1.2. Digital Input Function Block.....	11
1.3. Analog Input Function Block.....	13
1.4. Digital Output Function Block.....	18
1.5. Analog Output Function Block.....	21
1.6. PID Control Function Block.....	28
1.7. Lookup Table Function Block.....	30
1.8. Programmable Logic Function Block.....	35
1.9. Miscellaneous Function Block.....	40
2. INSTALLATION INSTRUCTIONS.....	42
2.1. Dimensions and Pinout.....	42
2.2. Installation Instructions	43
3. CANOPEN ® OBJECT DICTIONARY.....	45
3.1. NODE ID and BAUDRATE.....	45
3.1.1. LSS Protocol to Update.....	45
3.2. COMMUNICATION OBJECTS (DS-301 and DS-404).....	49
3.2.1. Object 1000h: Device Type.....	50
3.2.2. Object 1001h: Error Register.....	51
3.2.3. Object 1002h: Manufacturer Status Register.....	51
3.2.4. Object 1003h: Pre-Defined Error Field.....	51
3.2.5. Object 100Ch: Guard Time.....	53
3.2.6. Object 100Dh: Lifetime Factor.....	53
3.2.7. Object 1010h: Store Parameters.....	54
3.2.8. Object 1011h: Restore Parameters.....	55
3.2.9. Object 1016h: Consumer Heartbeat Time.....	57
3.2.10. Object 1017h: Producer Heartbeat Time.....	58
3.2.11. Object 1018h: Identity Object.....	58
3.2.12. Object 1020h: Verify Configuration.....	59
3.2.13. Object 1029h: Error Behaviour.....	60
3.2.14. RPDO Behaviour.....	61
3.2.15. TPDO Behaviour.....	64
3.3. APPLICATION OBJECTS (DS-404).....	66
3.3.1. Object 6020h: DI Read State 1 Input Line.....	67
3.3.2. Object 6030h: DI Polarity 1 Input Line.....	67
3.3.3. Object 7100h: AI Input Field Value.....	68
3.3.4. Object 6110h: AI Sensor Type.....	68
3.3.5. Object 6112h: AI Operating Mode.....	69
3.3.6. Object 7120h: AI Input Scaling 1 FV.....	69
3.3.7. Object 7121h: AI Input Scaling 1 PV.....	70
3.3.8. Object 7122h: AI Input Scaling 2 FV.....	70

3.3.9.	Object 7123h: AI Input Scaling 2 PV.....	71
3.3.10.	Object 7130h: AI Input Process Value.....	71
3.3.11.	Object 6132h: AI Decimal Digits PV.....	72
3.3.12.	Object 7148h: AI Span Start.....	72
3.3.13.	Object 7149h: AI Span End.....	73
3.3.14.	Object 61A0h: AI Filter Type.....	73
3.3.15.	Object 61A1h: AI Filter Constant.....	74
3.3.16.	Object 6220h: DO Write State 1 Output Line.....	75
3.3.17.	Object 6240h: DO Polarity 1 Output Line.....	75
3.3.18.	Object 6250h: DO Fault Mode 1 Output Line.....	76
3.3.19.	Object 6260h: DO Fault State 1 Output Line.....	76
3.3.20.	Object 7300h: AO Output Process Value.....	77
3.3.21.	Object 6302h: AO Decimal Digits PV.....	77
3.3.22.	Object 6310h: AO Output Type.....	78
3.3.23.	Object 7320h: AO Output Scaling 1 PV.....	78
3.3.24.	Object 7321h: AO Output Scaling 1 FV.....	79
3.3.25.	Object 7322h: AO Output Scaling 2 PV.....	80
3.3.26.	Object 7323h: AO Output Scaling 2 FV.....	80
3.3.27.	Object 7330h: AO Output Field Value.....	81
3.3.28.	Object 6332h: AO Decimal Digits FV.....	82
3.3.29.	Object 6340h: AO Fault Mode.....	82
3.3.30.	Object 7341h: AO Fault FV.....	83
3.3.31.	Object 7450h: PID Proportional Band.....	84
3.3.32.	Object 7452h: PID Integral Action Time.....	84
3.3.33.	Object 7454h: PID Derivative Action Time.....	85
3.3.34.	Object 7456h: PID Cycle Time.....	85
3.3.35.	Object 6458h: PID Physical Unit Timing.....	86
3.3.36.	Object 6459h: PID Decimal Digits Timing.....	86
3.4.	MANUFACTURER OBJECTS.....	87
3.4.1.	Object 2020h: DI Pull Up/Down Mode 1 Input Line.....	88
3.4.2.	Object 2030h: DI Debounce Filter 1 Input Line.....	89
3.4.3.	Object 2100h: AI Input Range.....	90
3.4.4.	Object 2101h: AI Number of Pulses Per Revolution.....	90
3.4.5.	Object 2102h: AI Decimal Digits FV.....	91
3.4.6.	Object 2103h: AI Filter Frequency for ADC.....	91
3.4.7.	Object 2110h: AI Error Detect Enable.....	92
3.4.8.	Object 2111h: AI Error Clear Hysteresis.....	93
3.4.9.	Object 2112h: AI Error Reaction Delay.....	93
3.4.10.	Object 2120h: AI Third-Order Filter Power.....	94
3.4.11.	Object 2121h: AI Third-Order Filter Input Coefficient N0.....	94
3.4.12.	Object 2122h: AI Third-Order Filter Input Coefficient N1.....	94
3.4.13.	Object 2123h: AI Third-Order Filter Input Coefficient N2.....	94

3.4.14. Object 2124h: AI Third-Order Filter Input Coefficient N3.....	94
3.4.15. Object 2125h: AI Third-Order Filter Output Coefficient N1.....	95
3.4.16. Object 2126h: AI Third-Order Filter Output Coefficient N2.....	95
3.4.17. Object 2127h: AI Third-Order Filter Output Coefficient N3.....	95
3.4.18. Object 2220h: DO Hotshot Current 1 Output Line.....	96
3.4.19. Object 2221h: DO Hold Current 1 Output Line.....	96
3.4.20. Object 2222h: DO Hotshot Time 1 Output Line.....	97
3.4.21. Object 2223h: DO Blink Rate 1 Output Line.....	98
3.4.22. Object 2300h: AO Override FV.....	99
3.4.23. Object 2310h: AO Error Detect Enable.....	99
3.4.24. Object 2311h: AO Error Clear Hysteresis.....	100
3.4.25. Object 2312h: AO Error Reaction Delay.....	100
3.4.26. Object 2320h: AO Dither Frequency.....	101
3.4.27. Object 2321h: AO Dither Amplitude.....	102
3.4.28. Object 2330h: AO Ramp Up.....	102
3.4.29. Object 2331h: AO Ramp Down.....	103
3.4.30. Object 2340h: AO Control Input Source.....	103
3.4.31. Object 2341h: AO Control Input Number.....	104
3.4.32. Object 2342h: AO Control Response.....	105
3.4.33. Object 2350h: AO Enable Input Source.....	105
3.4.34. Object 2351h: AO Enable Input Number.....	106
3.4.35. Object 2352h: AO Enable Response.....	107
3.4.36. Object 2360h: AO Override Input Source.....	107
3.4.37. Object 2361h: AO Override Input Number.....	108
3.4.38. Object 2362h: AO Override Response.....	108
3.4.39. Object 2370h: AO Feedback FV.....	109
3.4.40. Object 2380h: AO Output Frequency.....	110
3.4.41. Object 2381h: AO Current Sensor Averaging Time.....	110
3.4.42. Object 2382h: AO Current PID Proportional Gain.....	111
3.4.43. Object 2383h: AO Current PID Integral Time.....	111
3.4.44. Object 2384h: AO Current PID Derivative Time.....	112
3.4.45. Object 2450h: PID Tolerance.....	113
3.4.46. Object 2451h: PID Integral Gain.....	113
3.4.47. Object 2452h: PID Derivative Gain.....	114
3.4.48. Object 2453h: PID Target Source.....	114
3.4.49. Object 2454h: PID Target Number.....	115
3.4.50. Object 2455h: PID Feedback Source.....	116
3.4.51. Object 2456h: PID Feedback Number.....	116
3.4.52. Object 2457h: PID Control Response.....	117
3.4.53. Object 2460h: PID Output Field Value.....	117

3.4.54. Object 2500h: EC Extra Received PV.....	118
3.4.55. Object 2502h: EC Decimal Digits PV.....	119
3.4.56. Object 2520h: EC Scaling 1 PV.....	119
3.4.57. Object 2522h: EC Scaling 2 PV.....	120
3.4.58. Object 30z0h: LTz Input X-Axis Source.....	121
3.4.59. Object 30z1h: LTz Input X-Axis Number.....	121
3.4.60. Object 30z2h: LTz X-Axis Decimal Digits PV.....	122
3.4.61. Object 30z3h: LTz Y-Axis Decimal Digits PV.....	122
3.4.62. Object 30z4h: LTz Point Response.....	123
3.4.63. Object 30z5h: LTz Point X-Axis PV.....	123
3.4.64. Object 30z6h: LTz Point Y-Axis PV.....	124
3.4.65. Object 30z7h: LTz Output Y-Axis PV.....	125
3.4.66. Object 4000h: Logic Block Enable.....	125
3.4.67. Object 4010h: Logic Block Selected Table.....	126
3.4.68. Object 4020h: Logic Block Output PV.....	126
3.4.69. Object 4x01h: LBx Lookup Table Number.....	127
3.4.70. Object 4x02h: LBx Function Logical Operator.....	127
3.4.71. Object 4x11h: LBx Function A Condition 1.....	128
3.4.72. Object 4x12h: LBx Function A Condition 2.....	128
3.4.73. Object 4x13h: LBx Function A Condition 3.....	128
3.4.74. Object 4x21h: LBx Function B Condition 1.....	128
3.4.75. Object 4x22h: LBx Function B Condition 2.....	128
3.4.76. Object 4x23h: LBx Function B Condition 3.....	128
3.4.77. Object 4x31h: LBx Function C Condition 1.....	128
3.4.78. Object 4x32h: LBx Function C Condition 2.....	128
3.4.79. Object 4x33h: LBx Function C Condition 3.....	128
3.4.80. Object 5010h: Constant Field Value.....	129
3.4.81. Object 5020h: Power Supply FV.....	131
3.4.82. Object 5030h: Processor Temperature FV.....	131
3.4.83. Object 5555h: Start In Operational Mode.....	132

APPENDIX A – Technical Specifications..... A

LIST OF FIGURES

1A. Hardware Functional Block Diagram.....	8
1B. Logic Functional Block Diagram.....	9
2. Digital Input Objects.....	10
3. Digital Input Hysteresis.....	10
4. Digital Input Debouncing.....	11
5. Analog Input Read as Digital.....	12
6. Analog Input Objects.....	12
7. Analog Input Linear Scaling FV to PV.....	16
8. Digital Output Objects.....	18
9. Hotshot Digital Profile.....	20
10. Analog Output Objects.....	21
11. Analog Output Linear Scaling PV to FV.....	22
12. Analog Output Default Response Profile.....	25
13. Analog Output Logic Flowchart.....	27
14. PID Control Objects.....	28
15. PID Control Algorithm.....	29
16. Lookup Table Objects.....	30
17. Lookup Table Example Resistance vs. NTC Temperature.....	31
18. Lookup Table Defaults with Ramp and Step Responses.....	32
19. Lookup Table Examples to Setup for Dual-Slope Joystick Deadband Response.....	33
20. Lookup Table Time Response Clutch Fill Profiles.....	34
21. Logic Block Objects.....	35
22. Logic Block Flowchart.....	36
23. Miscellaneous Objects.....	40
24. Housing Dimensions.....	42

LIST OF TABLES

1. DI Pullup/Down Options.....	10
2. DI Debounce Filter Options.....	11
3. DI Polarity Options versus DI State.....	11
4. AI Operating Mode Options.....	12
5. AI Sensor Type Options.....	13
6. AI Input Range Options Depending on Sensor Type.....	13
7. ADC Filter Frequency Options.....	13
8. AI Filter Type Options.....	14
9. AI Decimal Digits FV Depending on Sensor Type.....	15
10. AI Object Defaults Based on Sensor Type and Input Range.....	17
11. AI Object Ranges Based on Sensor Type and Input Range.....	17
12. DO Polarity Options.....	19
13. DO Fault Mode Options.....	20
14. AO Output Type Options.....	21
15. Control Source Options.....	22
16. Control Number Options Depending on Source Selected.....	23
17. Scaling Limits Per Control Source.....	24
18. AO Control Response Options.....	25
19. AO Default Object Values.....	25
20. AO Enable Response Options.....	26
21. AO Override Response Options.....	26
22. AO Fault Mode Options.....	26
23. PID Response Options.....	29
24. LTz Point Response Options.....	33
25. LBx Condition Structure Definition.....	37
26. LBx Condition Operator Options.....	37
27. LBx Condition Evaluation Results.....	38
28. LBx Function Logical Operator Options.....	38
29. LBx Conditions Evaluation Based on Selected Logical Operator.....	39
30. LBx Default Lookup Tables.....	39
31. Connector Pinout.....	42
32. LSS Baudrate Indexes.....	47
33. Pre-Defined Error Codes.....	52

1. OVERVIEW OF CONTROLLER

1.1. Description of Single Input, Dual Output Controller

The following User Manual describes the architecture and functionality a dual output CANopen ® valve controller with one universal input, and a low power +5V reference voltage.

The Single Input, Dual Output Valve Controller (1i2o) is designed for extremely versatile control of the two proportional outputs to directly drive coils or other loads. Its flexible circuit design gives the user a wide range of configurable input or output types. The sophisticated control algorithms allow the user to program the controller for a wide range of applications without the need for custom software.

The two universal outputs can be setup to drive: proportional current (up to 3A each); hotshot digital current; proportional voltage (up to supply); proportional PWM; or straight on/off digital loads. Both outputs are high-side driven (sourcing) outputs.

The controller also has one fully programmable universal input that can be setup to read: voltage; current; resistive; frequency; or digital input signals. It also has a single +5Vref that can source up to 10mA to provide a reference for a potentiometer or low-power transducer.

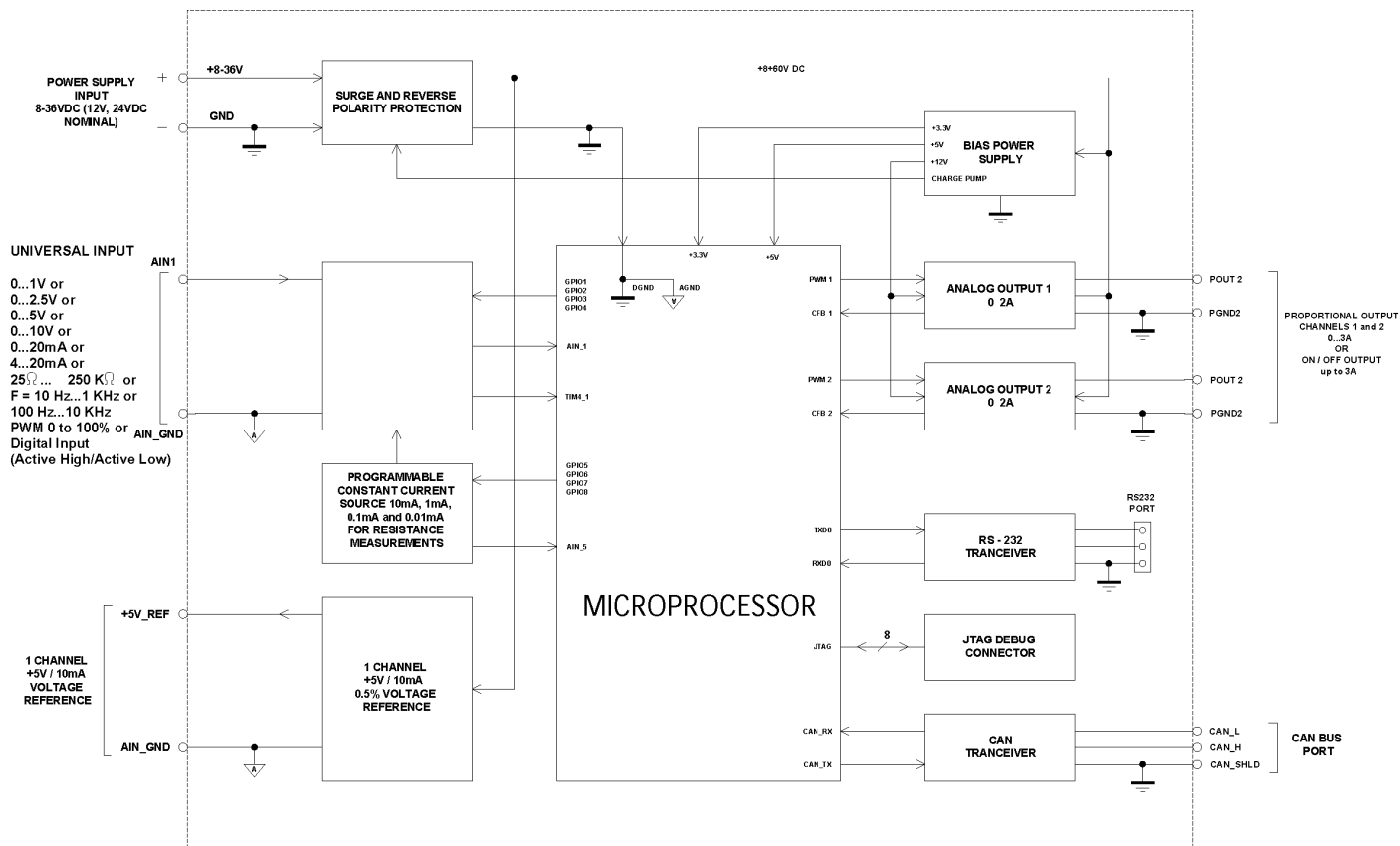

Figure 1A – Hardware Functional Block Diagram

The 1i2o is a highly programmable controller, allowing the user to configure it for their application. Its sophisticated control algorithms allow for open or closed loop drive of the proportional outputs. It can be operated as either a self-contained control system, driving the outputs directly from the on-board inputs, and/or it can be integrated into a CANopen® network of controllers. All I/O and logical function blocks on the unit are inherently independent from one another, but can be programmed to interact in a large number of ways. While Figure 1A shows the hardware features, Figure 1B shows the logical function blocks (software) available on the 1i2o.

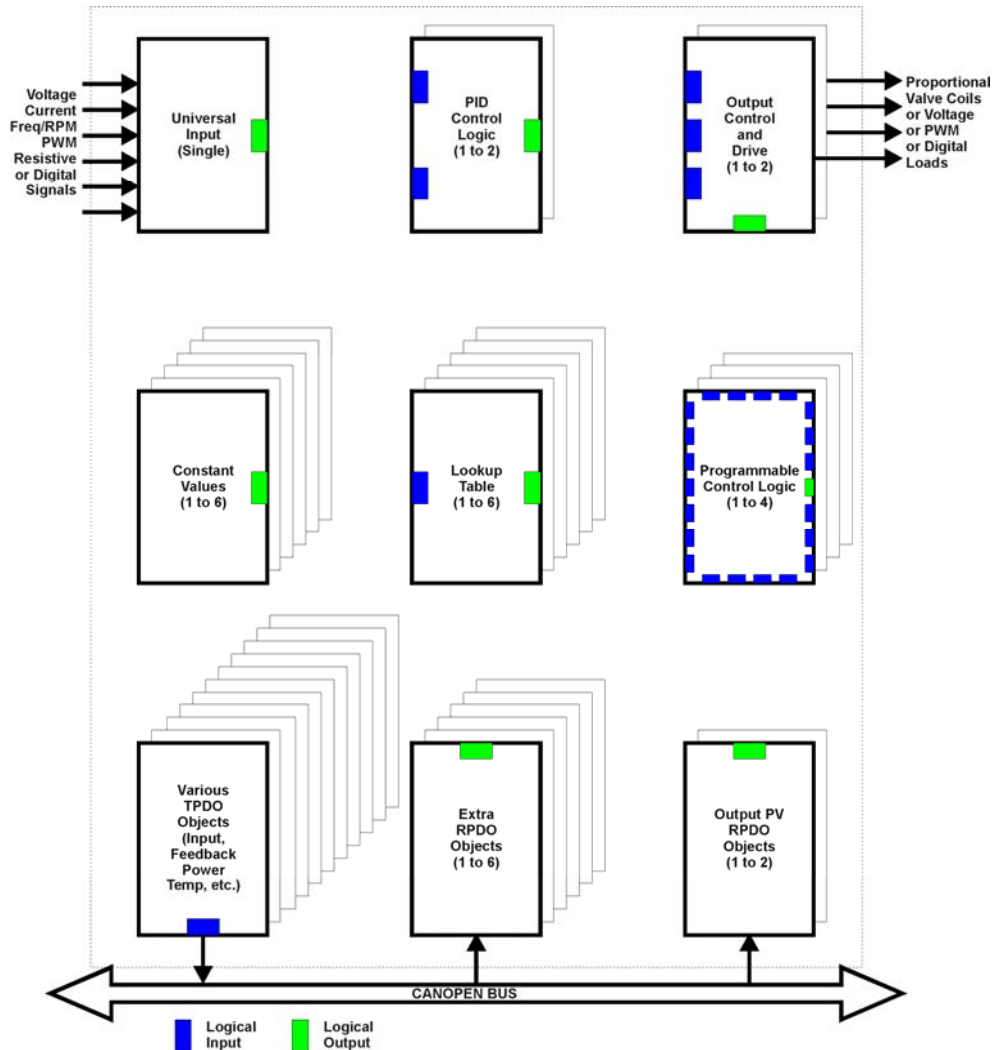

Figure 1B –Logic Functional Block Diagram

The 1i2o has a number of built-in protection features that can shutoff the outputs in adverse conditions. These features are described in detail in subsequent, and they include hardware shutoffs to protect the circuits from being damaged as well as software shutdown features that can be enabled in safety critical systems when an input or CAN fault is detected.

The various function blocks supported by the 1i2o are outlined in the following sections. All objects are user configurable using standard commercially available tools that can interact with a CANopen® Object Dictionary via an .EDS file.

1.2. Digital Input Function Block

The digital input (DI) function block only becomes applicable on the input when object 6112h, **AI Operation**, is set to a digital input response.

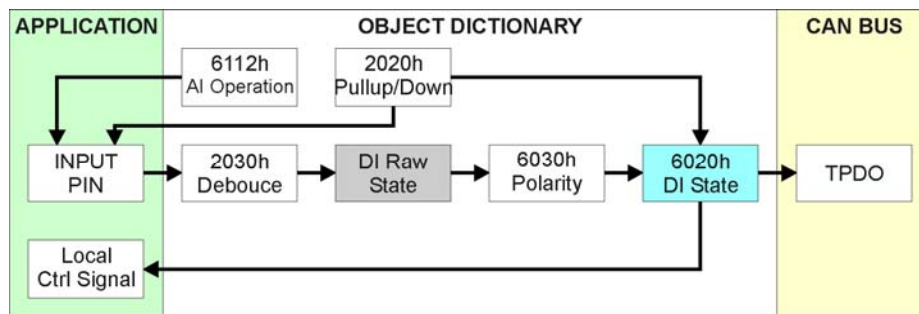

Figure 2 – Digital Input Objects

When 6112h is set to 10 = Digital Input, object 2020h **DI Pullup/Down Mode** will determine if the input signal is active high (10kΩ pulldown enabled, switch to +V) or active low (10kΩ pullup enabled, switched to GND) The options for object 2020h are shown in Table 1, with the default bolded.

Value	Meaning
0	Pullup/Down Disabled (high impedance input)
1	10kΩ Pullup Resistor Enabled (active low)
2	10kΩ Pulldown Resistor Enabled (active high)

Table 1 – DI Pullup/Down Options

Figure 3 shows the hysteresis on the input when switching a discrete signal. A digital input can be switched up to +V_{cc} (48V_{max}.)

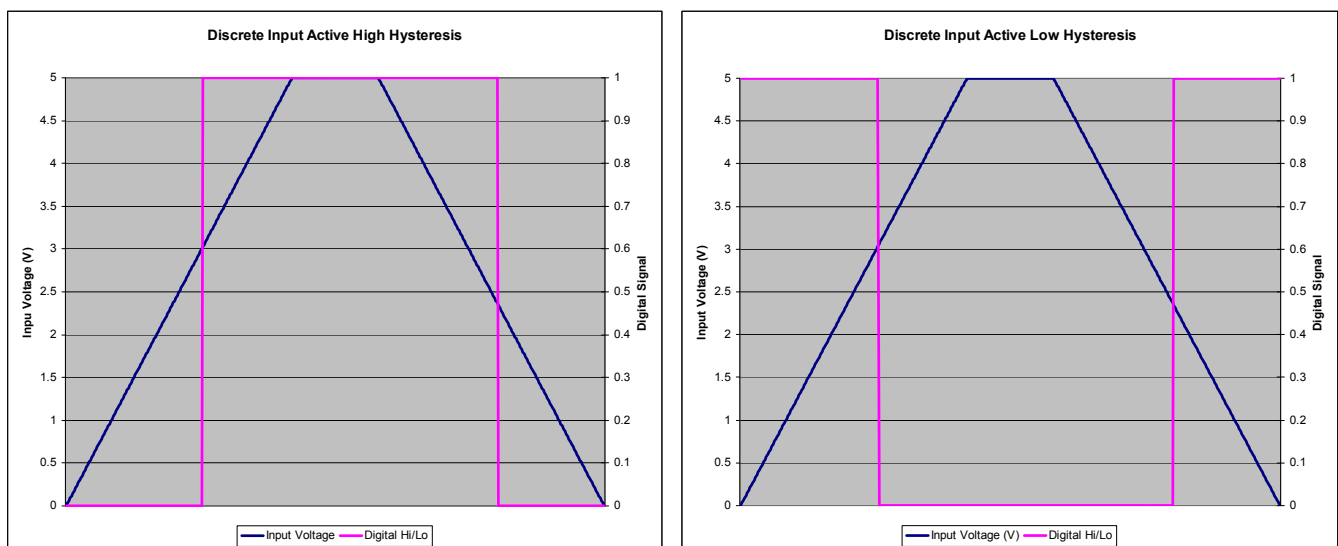

Figure 3 – Discrete Input Hysteresis

Object 2030h **DI Debounce Filter** is applied to the input before the state is read by the processor. The options for object 2030h are shown in Table 2, with the default bolded.

Value	Meaning
0	Filter Disabled
1	Filter 111ns
2	Filter 1.78 us
3	Filter 14.22 us

Table 2 – DI Debounce Filter Options

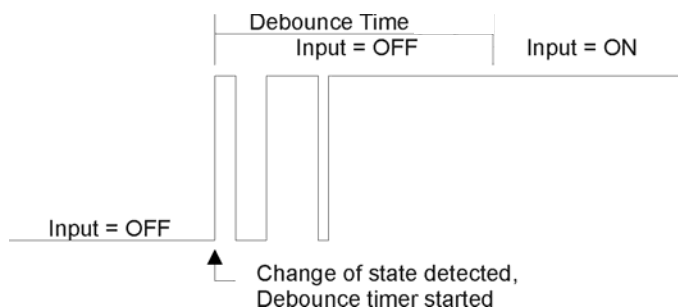

Figure 4 – Digital Input Debouncing

Once the raw state has been evaluated, the logical state of the input is determined by **object 6030h DI Polarity**. The options for object 6030h are shown in Table 3. The ‘calculated’ state of the DI that will be written to read-only object 6020h **DI Read State** will be a combination of active high/low and the polarity selected. By default, normal on/off logic is used.

Value	Meaning	Active High	Active Low	State
0	Normal On/Off	HIGH	LOW	ON
		LOW or Open	HIGH or Open	OFF
1	Inverse On/Off	HIGH	LOW	OFF
		LOW or Open	HIGH or Open	ON
2	Latched Logic	HIGH to LOW	LOW to HIGH	No Change
		LOW to HIGH	HIGH to LOW	State Change (i.e. OFF to ON)

Table 3 – DI Polarity Options versus DI State

There is another type of ‘digital’ input that can be selected when 6112h is set to 20 = Analog On/Off. However, in this case, the input is still configured as an analog input, and therefore the objects from the Analog Input (AI) block are applied instead of those discussed above. Here, objects 2020h, 2030h and 6030h are ignored, and 6020h is written as per the logic shown in Figure 5. In this case, the MIN parameter is set by object 7120h **AI Scaling 1 FV**, and the MAX is set by 7122h **AI Scaling 2 FV**.

For all other operating modes, object 6020h will always be zero.

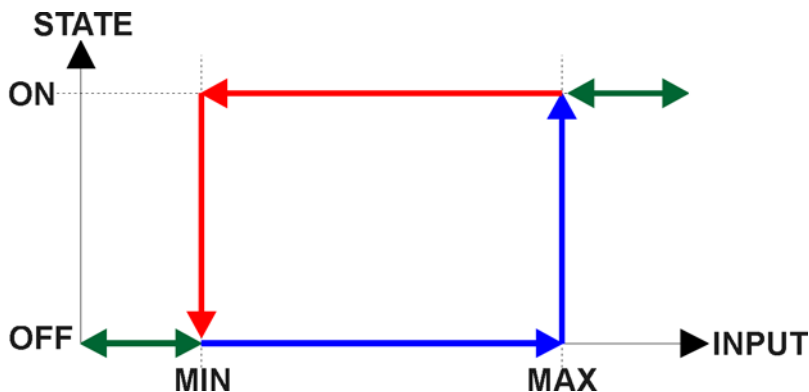

Figure 5 – Analog Input Read as Digital

1.3. Analog Input Function Block

The analog input (AI) function block is the default logic associate with the universal input.

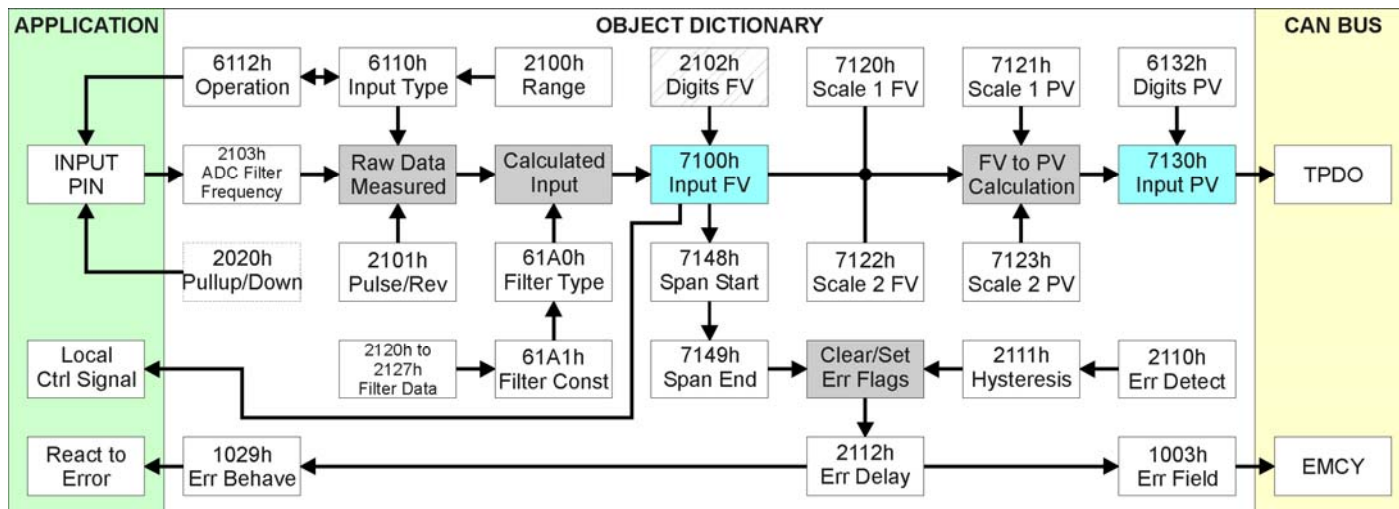

Figure 6 – Analog Input Objects

Object 6112h, **AI Operating Mode** determines whether the AI or DI function block is associated with input. The options for object 6112h are shown in Table 4. No values other than what are shown here will be accepted.

Value	Meaning
0	Channel Off
1	Normal Operation (analog)
10	Digital Input (on/off)
20	Analog and On/Off

Table 4 – AI Operating Mode Options

The most important object associate with the AI function block is object 6110h **AI Sensor Type**. By changing this value, and associated with it object 2100h **AI Input Range**, other objects will be automatically updated by the controller. The options for object 6110h are shown in Table 5, and no values other than what are shown here will be accepted. The input is setup to measure voltage by default.

Value	Meaning
40	Voltage Input
50	Current Input
60	Frequency Input (or RPM)
100	Resistive Input
10000	PWM Input

Table 5 – AI Sensor Type Options

The allowable ranges will depend on the input sensor type selected. Table 6 shows the relationship between the sensor type, and the associated range options. The default value for each range is bolded, and object 2100h will automatically be updated with this value when 6110h is changed. Grayed out cells mean that the associate value is not allowed for the range object when that sensor type has been selected.

Value	Voltage	Current	Frequency	Resistive	PWM
0	0 to 1V	0 to 20mA	0.5Hz to 50Hz	25Ω to 250kΩ	Low Freq (<1kHz)
1	0 to 2.5V	4 to 20mA	10Hz to 1kHz		High Freq (>100Hz)
2	0 to 5V		100Hz to 10kHz		
3	0 to 10V				

Table 6 – AI Input Range Options Depending on Sensor Type

Not all objects apply to all input types. For example, object 2103h **AI Filter Frequency for ADC** is only applicable with a voltage, current or resistive input is being measured. In these cases, the ADC will automatically filter as per Table 7, and is set for 50Hz noise rejection by default.

Value	Meaning
0	Input Filter Off
1	Filter 50Hz
2	Filter 60Hz
3	Filter 50Hz and 60Hz

Table 7 – ADC Filter Frequency Options

Conversely, frequency and PWM inputs use object 2020h **DI Pullup/Down Mode** (see Table 1) while voltage, current and resistive inputs set this object to zero. Also, a frequency input can be automatically turned into an RPM measurement instead simply by setting object 2101h **AI Number of Pulses Per Revolution** to a non-zero value. All other input types ignore this object.

Irregardless of type, however, all analog inputs can be further filtered once the raw data has been measured (either from ADC or Timer.) Object 61A0h **AI Filter Type** determines what kind of filter is used per Table 8. By default, additional software filtering is disabled.

Value	Meaning
0	No Filter
1	Moving Average
2	Repeating Average
3	Third-Order Low Pass

Table 8 – AI Filter Type Options

Object 61A1h **AI Filter Constant** is used with all three types of filters as per the formulas below:

Calculation with no filter:

Value = Input

The data is simply a ‘snapshot’ of the latest value measured by the ADC or timer.

Calculation with the moving average filter:

$$\text{Value}_N = \text{Value}_{N-1} + \frac{(\text{Input} - \text{Value}_{N-1})}{\text{FilterConstant}}$$

This filter is called every 1ms. The value FilterConstant stored in object 61A1h is 10 by default.

Calculation with the repeating average filter:

$$\text{Value} = \frac{\sum \text{Input}_N}{N}$$

At every reading of the input value, it is added to the sum. At every Nth read, the sum is divided by N, and the result is the new input value. The value and counter will be set to zero for the next read. The value of N is stored in object 61A1h, and is 10 by default. This filter is called every 1ms.

Calculation with the 3rd Order Low Pass filter:

$$\text{Value}_N = \frac{[C_{IN0} * \text{Input}_N + C_{IN1} * \text{Input}_{N-1} + C_{IN2} * \text{Input}_{N-2} + C_{IN3} * \text{Input}_{N-3} + C_{OUT1} * \text{Value}_{N-1} + C_{OUT2} * \text{Value}_{N-2} + C_{OUT3} * \text{Value}_{N-3}]}{2^{\text{Power}}}$$

C_{IN0} Coefficient for Input(n)

C_{IN1} Coefficient for Input(n-1)

C_{IN2} Coefficient for Input(n-2)

C_{IN3} Coefficient for Input(n-3)

C_{OUT1} Coefficient for Output(n-1)

C_{OUT2} Coefficient for Output(n-2)

C_{OUT3} Coefficient for Output(n-3)

This filter uses 16-bit fixed point math. Object 2120h **AI Third-Order Filter Power** tells the controller the shift value used when the coefficients were selected.

The value of object 61A1h determines how often the filter is called (in ms), and is set to 10 by default. In between calls, the data of the input signal is the value which was calculated the last time the filter was called. The filter coefficients are stored in objects 2121h to 2127h.

The value from the filter is shifted according to read-only object 2102h **AI Decimal Digits FV** and then written to read-only object 7100h **AI Input Field Value**.

The value of 2102h will depend on the AI Sensor Type and Input Range selected, and will be automatically updated per Table 9 when either 6110h or 2100h are changed. All other objects associated with the input field value also apply this object. These objects are 7120h **AI Scaling 1 FV**, 7122h **AI Scaling 2 FV**, 7148h **AI Span Start**, 7149h **AI Span End**, and 2111h **AI Error Clear Hysteresis**. These objects are also automatically updated when the Type or Range is changed.

Sensor Type and Range	Decimal Digits
Voltage: All Ranges	3 [mV]
Current: All Ranges	3 [uA]
Resistive: Full Range	2 [0.01 kΩ]
Frequency: 0.5Hz to 50Hz	2 [0.01 Hz]
Frequency: 10Hz to 1kHz	1 [0.1 Hz]
Frequency: 100Hz to 10kHz	0 [Hz]
Frequency: RPM Mode	1 [0.1 RPM]
PWM: All Ranges	1 [0.1 %]
Digital Input	0 [On/Off]

Table 9 – AI Decimal Digits FV Depending on Sensor Type

It is the AI Input FV which is used by the application for error detection, and as a control signal for other logic blocks (i.e. output control.) Object 7100h is mappable to a TPDO, and is mapped to TPDO1 by default.

Read-only object 7130h **AI Input Process Value** is also mappable. However, the default values for objects 7121h **AI Scaling 1 PV** and 7123h **AI Scaling 2 PV** are set to equal 7120h and 7122h respectively, while object 6132h **AI Decimal Digits PV** is automatically initialize to equal 2102h. This means that the default relationship between the FV and PV is one-to-one, so object 7130h is not mapped to a TPDO by default.

Should a different linear relationship between what is measured versus what is sent to the CANopen bus be desired, objects 6132h, 7121h and 7123h can be changed. The linear relationship profile is shown in Figure 7 below. Should a non-linear response be desired, the lookup table function block can be used instead, as described in section 1.7.

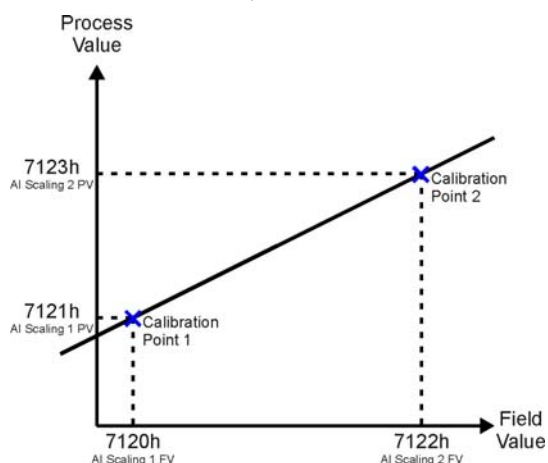

Figure 7 – Analog Input Linear Scaling FV to PV

As stated earlier, the FV scaling objects are automatically updated with the Sensor Type or Range changes. This is because objects 7120h and 7122h are not only used in a linear conversion from FV to PV as described above, but also as the minimum and maximum limits when the input is used to control another logic block. Therefore, the values in these objects are important, even when the AI Input PV object is not being used.

The AI Span Start and AI Span End objects are used for fault detection, so they too are automatically updated for sensible values as the Type/Range changes. The Error Clear Hysteresis object is also updated, as it too is measured in the same unit as the AI Input FV object.

Table 10 lists the default values that are loaded into objects 7120h, 7122h, 7148h, 7149h, and 2111h for each Sensor Type and Input Range combination. Recall that these objects all have the decimal digits applied to them as outlined in Table 9.

Sensor Type/ Input Range	7148h AI Span Start (i.e. Error Min)	7120h AI Scaling 1 FV (i.e. Input Min)	7122h AI Scaling 2 FV (i.e. Input Max)	7149h AI Span End (i.e. Error Max)	2111h Error Clear Hysteresis
Voltage: 0 to 1V	50 [mV]	100 [mV]	1000 [mV]	1050 [mV]	25 [mV]
Voltage: 0 to 2.5V	100 [mV]	250 [mV]	2500 [mV]	2600 [mV]	50 [mV]
Voltage: 0 to 5V	200 [mV]	500 [mV]	4500 [mV]	4800 [mV]	100 [mV]
Voltage: 0 to 10V	200 [mV]	500 [mV]	9500 [mV]	9800 [mV]	200 [mV]
Current: 0 to 20mA	0 [uA]	0 [uA]	20000 [uA]	20000 [uA]	250 [uA]
Current: 4 to 20mA	1000 [uA]	4000 [uA]	20000 [uA]	21000 [uA]	250 [uA]
Resistive: 0.025 to 250kΩ	2 [0.01kΩ]	10 [0.01kΩ]	20000 [0.01kΩ]	25000 [0.01kΩ]	1 [0.01kΩ]
Freq: 0.5Hz to 50Hz	100 [0.01Hz]	500 [0.01Hz]	5000 [0.01Hz]	5500 [0.01Hz]	20 [0.01Hz]
Freq: 10Hz to 1kHz	50 [0.1Hz]	100 [0.1Hz]	10000 [0.1Hz]	11000 [0.1Hz]	50 [0.1Hz]
Freq: 100Hz to 10kHz	50 [Hz]	100 [Hz]	10000 [Hz]	10500 [Hz]	10 [Hz]
Freq: RPM Mode	500 [0.1RPM]	1000 [0.1RPM]	30000 [0.1RPM]	33000 [0.1RPM]	100 [0.1RPM]
PWM: 0 to 100%	10 [0.1%]	50 [0.1%]	950 [0.1%]	990 [0.1%]	10 [0.1%]
Digital Input	OFF	OFF	ON	ON	0

Table 10 – AI Object Defaults Based on Sensor Type and Input Range

When changing these objects, Table 11 outlines the range constraints places on each based on the Sensor Type and Input Range combination selected. In all cases, the MAX value is the upper end of the range (i.e. 5V or) Object 7122h cannot be set higher than MAX, whereas 7149h can be set up to 110% of MAX. Object 2111h on the other hand can only be set up to maximum value of 10% of MAX. Table 11 uses the base unit of the input, but recall the limits will also have object 2102h apply to them as per Table 9.

Sensor Type/ Input Range	7148h	7120h	7122h	7149h	2111h
Voltage: 0 to 1V, 0 to 2.5V, 0 to 5V and 0 to 10V Current: 0 to 20mA RPM: 0 to 6000RPM PWM: 0 to 100%	0 to 7120h	7148h to 7122h	7120h to 7149h If(7149h>MAX) 7120h to MAX	7122h to 110% of MAX	10% of MAX
Current: 4 to 20mA	0 to 7120h	7148h to 7122h If(7148h<4mA) 4mA to 7122h			
Resistive: 0.025 to 250kΩ	25Ω to 7120h	7148h to 7122h			
Freq: 0.5Hz to 50Hz	0.1Hz to 7120h	7148h to 7122h If(7148h<0.5Hz) 0.5Hz to 7122h			
Freq: 10Hz to 1kHz	5Hz to 7120h	7148h to 7122h If(7148h<10Hz) 10Hz to 7122h			
Freq: 100Hz to 10kHz	50Hz to 7120h	7148h to 7122h If(7148h<100Hz) 100Hz to 7122h			

Table 11 – AI Object Ranges Based on Sensor Type and Input Range

The last objects associated with the analog input block left to discuss are those associated with fault detection. Should the calculated input (after measuring and filtering) fall outside of the allowable range, as defined by the AI Span Start and AI Span End objects, an error flag will be set in the application if and only if object 2110h **AI Error Detect Enabled** is set to TRUE (1).

When (7100h AI Input FV < 7148h AI Span Start), an “Out of Range Low” flag is set. If the flag stays active for the 2112h **AI Error Reaction Delay** time, an Input Overload Emergency (EMCY) message will be added to object 1003h **Pre-Defined Error Field**. Similarly, when (7100h AI Input FV > 7149h AI Span End), an “Out of Range High” flag is set, and will create an EMCY message should it stay active throughout the delay period. In either case, the application will react to the EMCY message as defined by object 1029h **Error Behaviour** at the sub-index corresponding to an Input Fault. Refer to section 3.2.4 and 3.2.13 for more information about objects 1003h and 1029h.

Once the fault has been detected, the associate flag will be cleared only once the input comes back into range. Object 2111h **AI Error Clear Hysteresis** is used here so that the error flag will not be set/cleared continuously while the AI Input FV hovers around the AI Span Start/End value.

To clear an “Out of Range Low” flag, AI Input FV \geq (AI Span Start + AI Error Clear Hysteresis)
 To clear an “Out of Range High” flag, AI Input FV \leq (AI Span End - AI Error Clear Hysteresis)
 Both flags cannot be active at once. Setting either one of these flags automatically clears the other.

1.4. Digital Output Function Block

The digital output (DO) function block only becomes applicable on the output when object 6130h, **AO Output Type**, is set to a digital output response (Type=1000 or 1020).

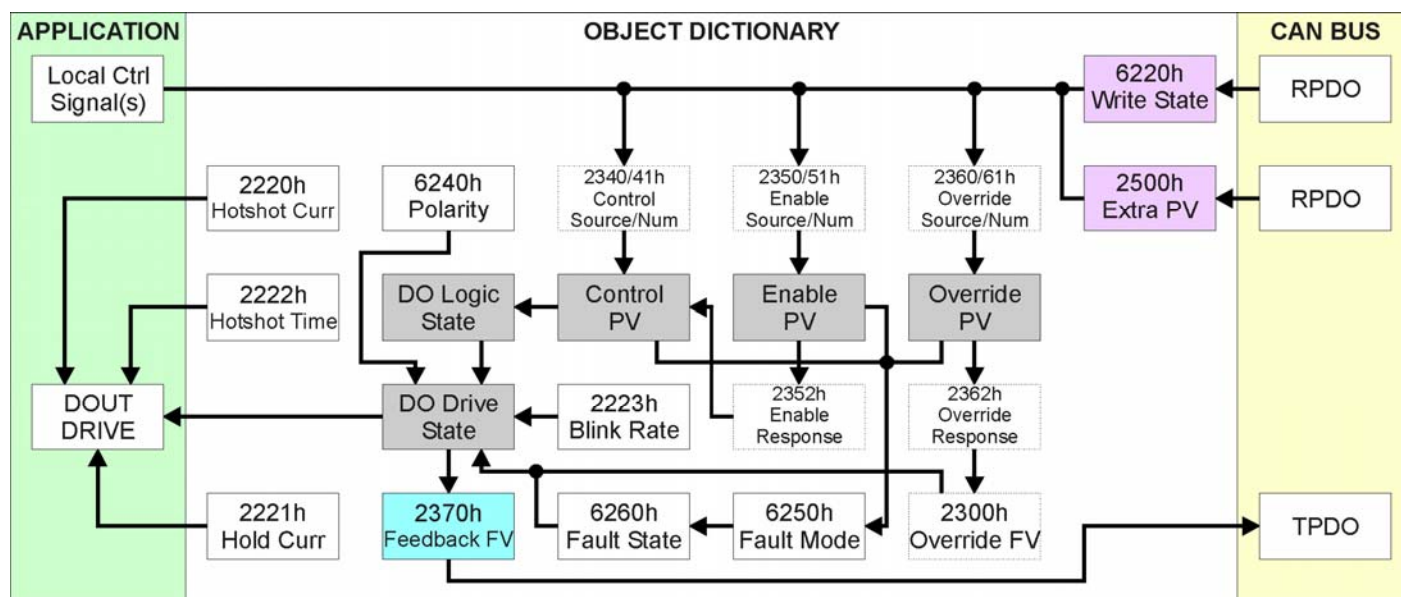

Figure 8 – Digital Output Objects

Several of the objects shown in the above diagram are actually associated with the Analog Output function block, and are explained in detail in section 1.5. Therefore, this section will only elaborate on the objects unique to the DO function block.

An output can be controlled either by an on-board control signal (such as the analog input or the result from a lookup table function) or a CANopen object that has mapped to an RPDO. In the case of an output configured for a digital response, when a CANopen Message has been selected as the 2340h **AO Control Input Source** (see Table 15), then data from the appropriate sub-index from write-mappable object 6220h **DO Write State** will be used as the control signal.

The Enable and Override Inputs and Responses for a digital output are the same as for an Analog Output, and are evaluated in the same order. Therefore, what is described in section 1.5 for these also applied for the DO function block.

As with the AO function, the output will respond to the Control Input if and only if the following conditions have been met:

- a) No fault is detected for any of the control signals
- b) The override command is either ignored or false (Override Input)
- c) The output has not been disabled by a secondary signal (Enable Input)

When the output is being driven by the Control Input, the “DO Logic State” is set OFF when the Control Input is zero, and is considered to be ON whenever a non-zero value is written.

The resulting “DO Drive State” will depend on the object 6240h **DO Polarity**, as per Table 12. By default, normal on/off output logic is used.

Value	Meaning	DO Logic State	DO Drive State
0	Normal On/Off	OFF	OFF
		ON	ON
1	Inverse On/Off	OFF	ON
		ON	OFF
2	Latched Logic	ON to OFF	No Change
		OFF to ON	State Change (i.e. OFF to ON)
3	Blinking Logic	OFF	OFF
		ON	Toggleing OFF and ON at the rate defined in object 2223h DO Blink Rate (in ms)

Table 12 – DO Polarity Options

The read-only mappable object 2370h **AO Feedback FV** will be loaded with the “DO Drive State” (0=OFF, 1=ON) when the output is setup for a digital type.

Outside of a straight ON/OFF digital output (where ON = +Vps applied to output pin), there is a second type of digital output called a “Hotshot.” This output is designed to work with inductive loads (i.e. a hydraulic valve) that can be hotshot with a high current for a short period of time to fully open the load. Then, the current is dropped back to a lower holding value to keep it open until the “DO Drive State” turns off as shown in Figure 9.

Objects 2220h **DO Hotshot Current**, 2221h **DO Hold Current**, and 2222h **DO Hotshot Time** are used with this output type to drive the load. Since the output timer is used for the hotshot time, DO Polarity option 3, Blinking Logic does not apply with this output type. The response in this case will be the same as option 1, Normal On/Off logic.

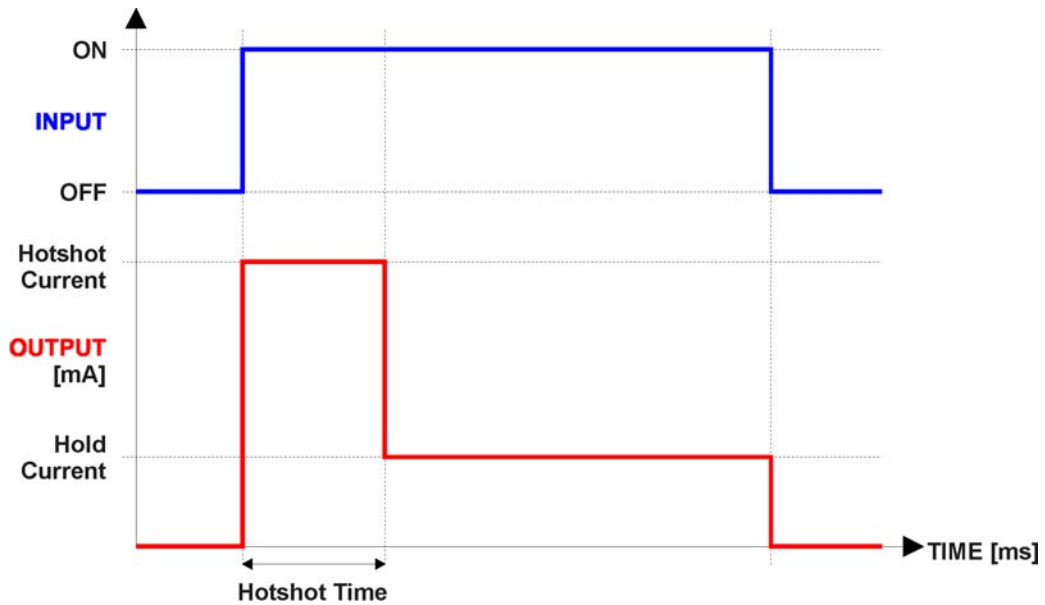

Figure 9 – Hotshot Digital Profile

As mentioned earlier, the output can be setup to react to a fault detected on any of the inputs to the function block (control, enable or override.) Should any one of these inputs be showing an error condition, object 6250h **DO Fault Mode** determines how the output will respond, per Table 13. By default, the output will revert to the state defined in object 6260h **DO Fault State**.

Value	Meaning
0	Maintain Last State
1	Apply Pre-Defined State

Table 13 – DO Fault Mode Options

1.5. Analog Output Function Block

The analog output (AO) function block is the default logic associate with both of the outputs.

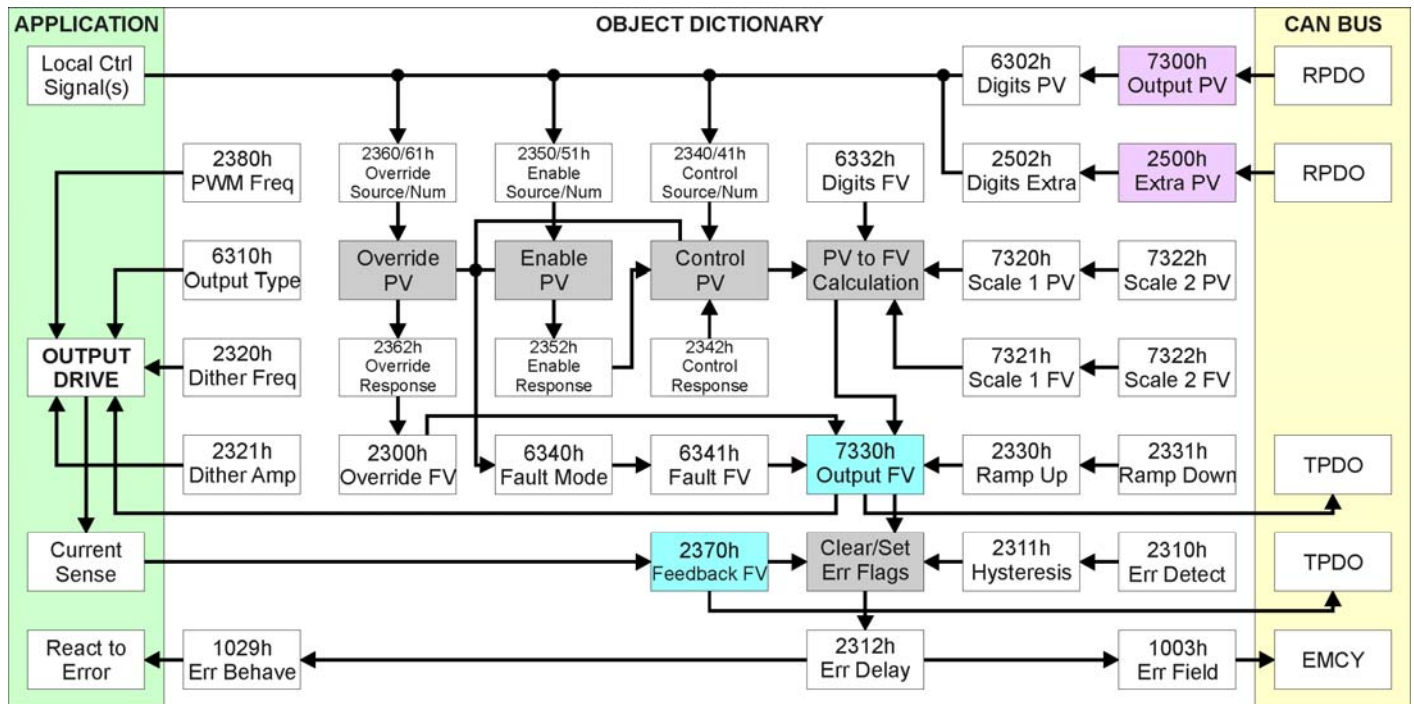

Figure 10 – Analog Output Objects

There are many objects associated with the analog output function block, but not all of them apply to all output types or control conditions. To start with, object 6310h **AO Output Type** defines how the output drive circuitry will be configured as per Table 14. This table also shows the output unit and range for each type. By default, both outputs are configured as proportional current types.

Value	Meaning	Range [Unit]
0	Output Disabled	N/A
10	Output Voltage	0 to 70 [V]
20	Output Current	0 to 3000 [mA]
40	Output PWM	0 to 100 [%]
1000	Output Digital On/Off	0 (OFF) or 1 (ON)
1020	Output Digital Hotshot	0 (OFF) or 1 (ON)

Table 14 – AO Output Type Options

The Current output has been factory calibrated for a close-loop PID control, and these objects should not be changed without proper consideration (see page 26.) In Voltage mode, the output is actually a high frequency PWM signal that is being adjusted by the processor such that the average voltage would match the target FV, up to the supply voltage. External filtering of the signal would have to be applied to get a true DC voltage. In PWM mode, the FV represents the output duty cycle. The digital output types have been covered in section 1.4

As with the analog input function block, the relationship between the Process Value (input) and the Field Value (output) is a linear one, as shown in Figure 11. However, unlike with the AI, the output will actually use the AO Scaling FV objects as limits to the drive, such that the output will hold at the minimum and maximum FV points, as shown in the figure.

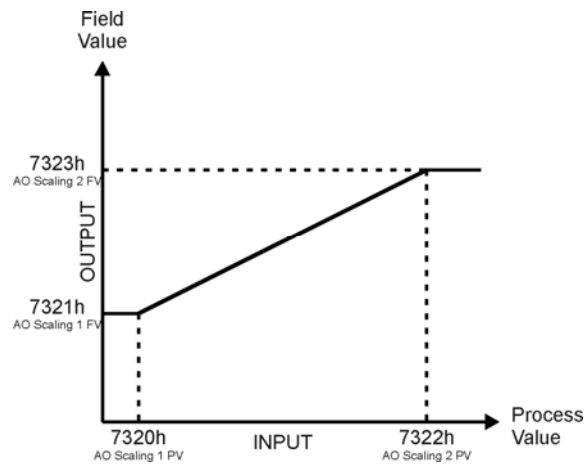

Figure 11 – Analog Output Linear Scaling PV to FV

An interesting feature of the 1i2o is that the source for the PV input can be selected from the list of the logical function blocks supported by the controller as shown in Figure 1B. Any output from one function block can be selected as the control source for another. Not all options make sense in all cases, but the complete list of control sources is shown in Table 15. By default, both outputs are setup to respond to the analog input, as shown in Figure 12.

Value	Meaning
0	Control Source Not Used (Ignored)
1	CANopen Message (RPDO)
2	Analog Input Function Block
3	Constant Function Block
4	PID Control Function Block
5	Lookup Table Function Block
6	Programmable Logic Function Block
7	Output Commanded Field Value
8	Output Feedback Field Value
9	Power Supply Measured
10	Processor Temperature Measured
11	Logic Selected Table Feedback

Table 15 – Control Source Options

In addition to a source, each control also has a number which corresponds to the sub-index of the function block in question. Table 16 outlines the ranges supported for the number objects, depending on the source that had been selected.

Control Source	# Range	Object (Meaning)
Control Source Not Used	0	Ignored
CANopen Message (RPDO)	1	7300h sub-index 1 or 6220h sub-index 1*
	2	7300h sub-index 2 or 6220h sub-index 2*
	3	2500h sub-index 1 (Extra Received PV 1)
	4	2500h sub-index 2 (Extra Received PV 2)
	5	2500h sub-index 3 (Extra Received PV 3)
	6	2500h sub-index 4 (Extra Received PV 4)
	7	2500h sub-index 5 (Extra Received PV 5)
	8	2500h sub-index 6 (Extra Received PV 6)
Analog Input Function Block	1	7100h sub-index 1 or 6020h sub-index 1**
Constant Function Block	1	5010h sub-index 1 (always FALSE)
	2	5010h sub-index 2 (always TRUE)
	3	5010h sub-index 3 (Constant FV 3)
	4	5010h sub-index 4 (Constant FV 4)
	5	5010h sub-index 5 (Constant FV 5)
	6	5010h sub-index 6 (Constant FV 6)
PID Control Function Block	1	2460h sub-index 1 (PID Output FV 1)
	2	2460h sub-index 2 (PID Output FV 2)
Lookup Table Function Block	1	3017h (Lookup Table 1 Output Y-Axis PV)
	2	3027h (Lookup Table 2 Output Y-Axis PV)
	3	3037h (Lookup Table 3 Output Y-Axis PV)
	4	3047h (Lookup Table 4 Output Y-Axis PV)
	5	3057h (Lookup Table 5 Output Y-Axis PV)
	6	3067h (Lookup Table 6 Output Y-Axis PV)
Programmable Logic Function Block	1	30z7 (Lookup Table Selected by Logic 1)
	2	30z7 (Lookup Table Selected by Logic 2)
	3	30z7 (Lookup Table Selected by Logic 3)
	4	30z7 (Lookup Table Selected by Logic 4)
<i>NOTE: The following options are meant more for diagnostic feedback, and should not be selected as a control source for logic inputs (i.e. output control or lookup table X-Axis)</i>		
Output Commanded Field Value	1	7330h sub-index 1 or "DO1 Logic State"
	2	7330h sub-index 2 or "DO2 Logic State"
Output Feedback Field Value	1	2370h sub-index 1 (AO1 FB or DO1 State)
	2	2370h sub-index 2 (AO2 FB or DO2 State)
Power Supply Measured	0 or 1	5020h (Power Supply FV)
Processor Temperature Measured	0 or 1	5030h (Processor Temperature FV)
Logic Selected Table Feedback	1	4140h (Logic Block 1 Selected Table)
	2	4240h (Logic Block 2 Selected Table)
	3	4340h (Logic Block 3 Selected Table)
	4	4440h (Logic Block 4 Selected Table)

* Depending on AO Output Type selected, either the AO Output PV or DO Write State will be used

** Depending on AI Operation selected, either the AI Input FV or DI Read State will be used

Table 16 – Control Number Options Depending on Source Selected

For the analog outputs (and digital), there are three inputs to the function block, each one with a unique source and number object. For the control function (PV axis in Figure 11), objects 2340h **AO Control Input Source** and 2341h **AO Control Input Number** are used. For the enable function, objects 2350h **AO Enable Input Source** and 2351h **AO Enable Input Number** are used. Lastly, for the override function, objects 2360h **AO Override Input Source** and 2361h **AO Override Input Number** are used.

When using any control source as the X-Axis input to a function block, the corresponding scaling limits are defined as per Table 17. It is the responsibility of the user to make sure that the scaling objects for any function block are setup appropriately depending on the source selected for the X-Axis input.

In the case of the analog output block, for digital signals such as the enable or override, the data is interpreted per Figure 5 for analog inputs. Note that for the Outputs, the actual objects for the scaling (6302h, 7320h, 7322h) should be edited to match the objects defined in this table when the control source is changed.

The only condition under which these objects are automatically updated is when an Output is being controlled by the Analog Input Function Block, and the input Sensor Type and/or Range is changed. For other function blocks using the AI as the control source, however (i.e. a Lookup Table or PID Feedback), the scaling objects do not updated automatically when the input changes.

Control Source	Scaling 1	Scaling 2	Dec Digits
CANopen Message – Num 1 or 2	7230h	7322h	6302h
CANopen Message – Num 3 to 8	2520h	2522h	2502h
Analog Input Function Block	7120h	7122h	6132h
Constant Function Block	N/A	N/A	N/A (float)
PID Control Function Block	0%	100%	1 (fixed)
Lookup Table Z Function Block (where Z = 1 to 6)	0 or lowest from 30z6h ⁽¹⁾	100 or highest from 30z6h ⁽²⁾	30z3h
Programmable Logic Function	0%	100%	1 (fixed)
Output Commanded Field Value	7230h	7322h	6302h
Output Feedback Field Value	7230h	7322h	6302h
Power Supply Measured	0V	70V	N/A (float)
Processor Temperature Measured	-50.0°C	150°C	N/A (float)
Logic Selected Table Feedback	N/A	N/A	N/A

(1) *Whichever value is smaller, (2) Whichever value is larger*

Table 17 – Scaling Limits Per Control Source

As shown in Figure 11, the Output FV will be calculated based on the FV scaling selected. Since 7321h represents the value at or below the lowest control input received, it represents the minimum field value that will be applied at the output. Similarly, 7323h represents the maximum FV that will be applied.

While (7320h < 7322h) must always hold true, in order to get an inverse response (i.e. output decreases as the input increased), simply set 7321h higher than 7323h.

In general, the profile shown in Figure 11 holds true. However, in some cases it may be desired that the minimum offset not be applied when the value is outside of the range, i.e. when using a joystick profile with a deadband. For this reason, object 2342h **AO Control Response** has the options shown in Table 18.

Value	Meaning
0	Single Output Profile (Figure 11)
1	Output OFF below Scaling 1 PV
2	Output OFF above Scaling 2 PV

Table 18 – AO Control Response Options

The default configuration for the 1i2o valve controller is that both current outputs are responding to changes from the single input configured as a 0-5V voltage type. The objects defaults listed in Table 19 result in the output response shown in Figure 12.

Object (Meaning)	Analog Output 1	Analog Output 2
7300h (AO Output PV)	Not Used	Not Used
6302h (AO Decimal Digits PV)	3 (2102h, AI Dec Digits FV)	3 (2102h, AI Dec Digits FV)
6310h (AO Output Type)	20 (Current)	20 (Current)
7320h (AO Scaling 1 PV)	2650 (2.65V)	500 (0.5V)
7321h (AO Scaling 1 FV)	300 [mA]	1500 [mA]
7322h (AO Scaling 2 PV)	4500 (4.5V)	2350 (2.35V)
7323h (AO Scaling 2 FV)	1500 [mA]	300 [mA]
6332h (AO Decimal Digits FV)	0 [mA]	0 [mA]
2340h (AO Control Input Source)	2 (AI Function Block)	2 (AI Function Block)
2341h (AO Control Input Number)	1 (AI Input 1)	1 (AI Input 1)
2342h (AO Control Response)	1 (OFF below Scaling 1 PV)	2 (OFF above Scaling 2 PV)
6340h (AO Fault Mode)	1 (Apply Pre-Defined FV)	1 (Apply Pre-Defined FV)
7341h (AO Fault FV)	500 [mA]	500 [mA]

Table 19 – AO Default Object Values

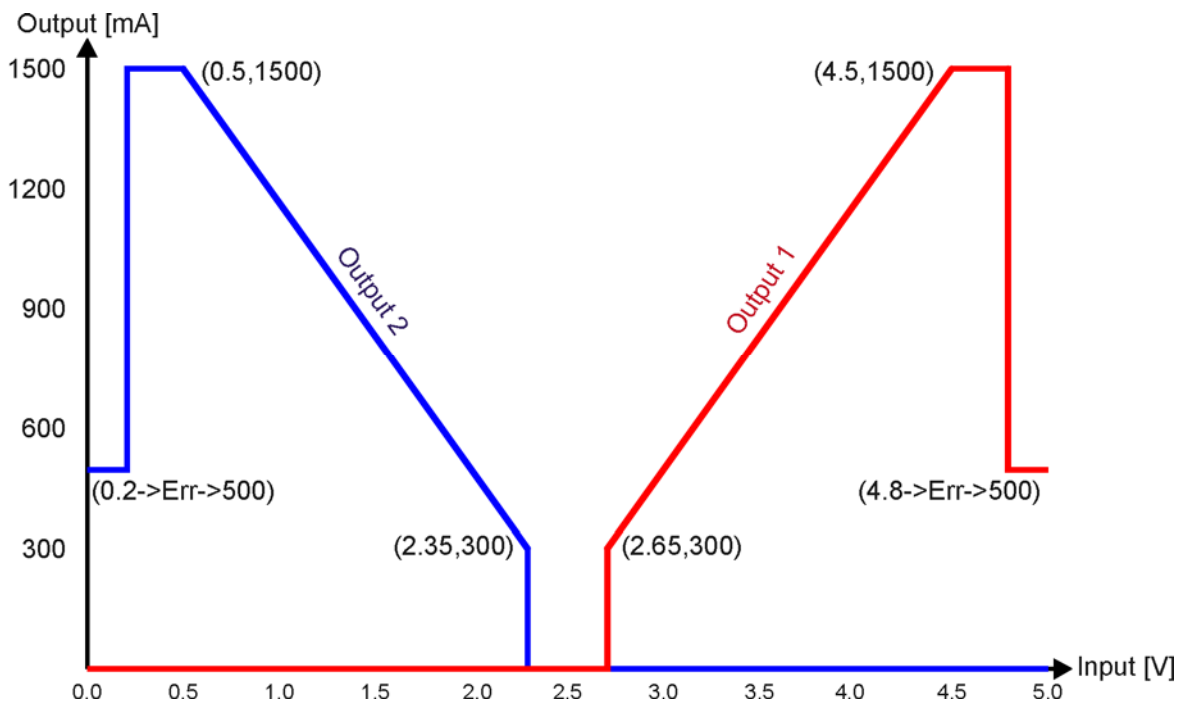

Figure 12 – Analog Output Default Response Profile

Enable and Override inputs have been mentioned several times already. By default, neither inputs are used (control sources are set to 0=Ignore), but they can be activated for safety interlocks or other more complex applications. Tables 20 and 21 show the options for object 2352h **AO Enable Response**, and 2362h **AO Override Response** respectively. In both cases, the default responses are bolded. When the override is applied, the output is driven to the value defined in object 2300h, **AO Override FV**.

Value	Meaning
0	Enable When ON
1	Disable When ON

Table 20 – AO Enable Response Options

Value	Meaning
0	Override When ON
1	Override When OFF

Table 21 – AO Override Response Options

As shown in Figure 12, the output can be setup to react to a fault detected on any of the inputs to the function block (control, enable or override.) Should any one of these inputs be showing an error condition, object 6340 **AO Fault Mode** determines how the output will respond, per Table 22. By default, the output will be driven to the value defined in object 7341h **AO Fault FV**.

Value	Meaning
0	Maintain Last State
1	Apply Pre-Defined FV

Table 22 – AO Fault Mode Options

The controller applies the logic shown in Figure 13 when evaluating what output FV to apply. Under normal conditions, i.e. when the control input is driving the output as shown in the green box, there are ramping objects that can be applied to soften the output response. Object 2330h **AO Ramp Up** and object 2331 **AO Ramp Down** are both millisecond numbers that define how long it will take to ramp from AO Scaling 1 FV to AO Scaling 2 FV.

Object 2320h **AO Dither Frequency** and object 2321h **AO Dither Amplitude** are only applicable with current output types. The dither is a low frequency signal that is superimposed on-top of the high frequency output. While the dither frequency will match exactly what is in object 2320h, the exact amplitude of the dither will depend on the properties of the coil. When adjusting 2321h, select a value that is high enough to ensure an immediate response to the coil to small changes in the control inputs, but not so large as to effect the accuracy or stability of the output. If 2321h is set to zero, dithering is disabled.

By default, current and voltage outputs are driven with a high frequency 25kHz signal. This value should not be lowered in this mode without taking into consideration how this affects the accuracy and stability of the current through the load. However, in PWM output mode, object 2380h **AO Output Frequency** can and should be adjusted to the desired frequency.

There are four other objects associated with the close-loop PID control of the current through an inductive load. These objects have been factory calibrated, and should not be changed. However, the user does have access to these objects in the unlikely case that they should be adjusted. These objects are 2381h, **AO Current Sense Averaging Time**, 2382h, **AO Current PID Proportional Gain**, 2383h **AO Current PID Integral Time**, and 2384h **AO Current PID Derivative Time**. These objects must not be confused with PID objects in the PID function block which operates independently of the close-loop current control.

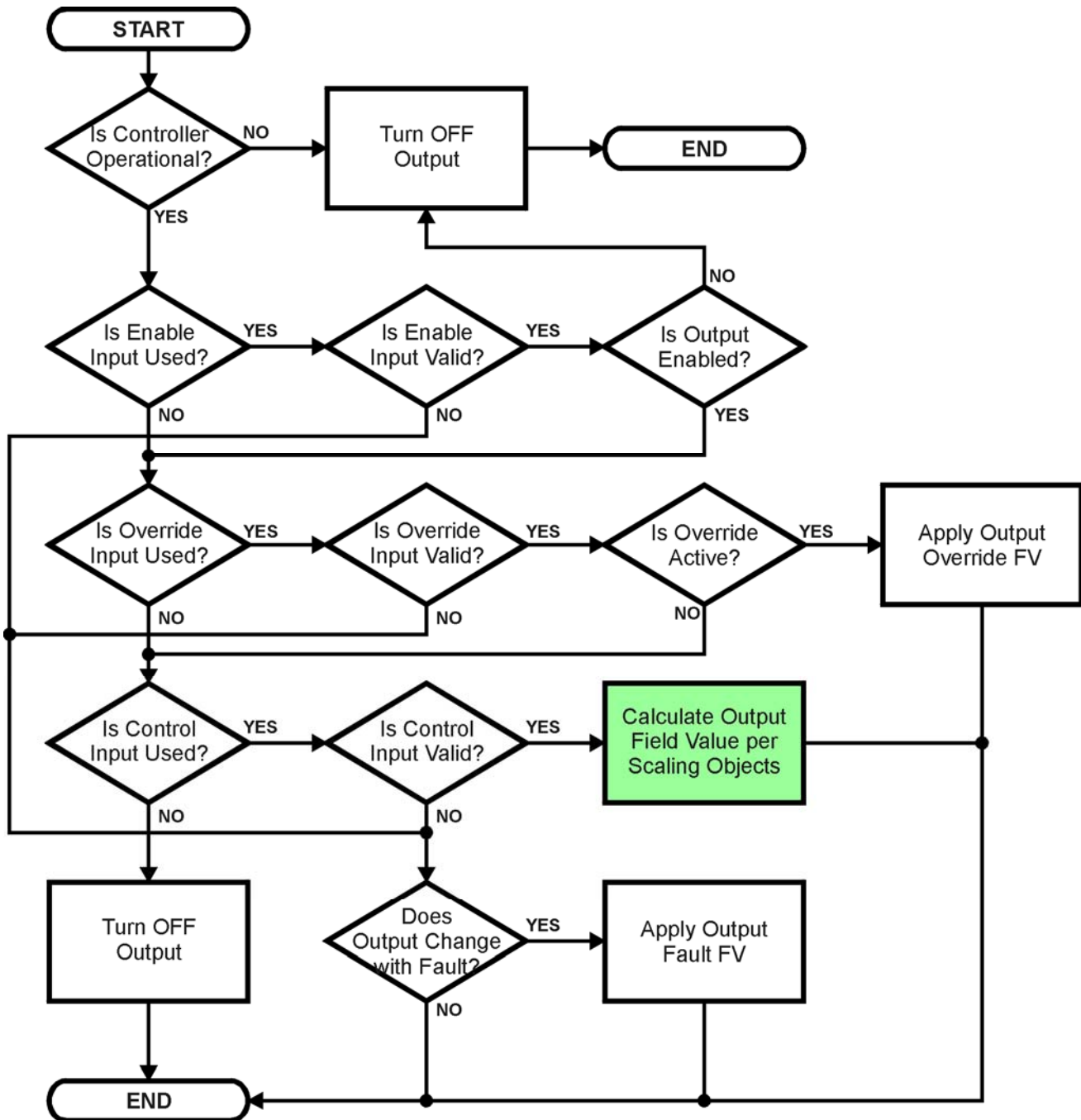

Figure 13 – Analog Output Logic Flowchart

In addition to the read-only mappable object 7330h **AO Output Field Value** (as represented by the green box above), there is another object 2370h **AO Feedback FV**, also read-only mappable. This object reflects the actual measured value at the output. It is also used to detect and flag an error if there is an open or short circuit at the output.

If object 2310h **AO Error Detect Enable** is set to TRUE, then the absolute value between the desired output FV (7330h) and the measured feedback (2370h) is compared to 2311h **AO Error Clear Hysteresis**. If the difference between the target and the actual exceeds the hysteresis value, then a fault is present. Since both open and short circuits read close to zero feedback, a signal is also sent to the processor whenever a short (to either GND or +Vcc) has occurred.

The controller will then flag an “Open Circuit” or “Short Circuit” fault. Both flags cannot be active at once. Setting either one of these flags automatically clears the other. If either flag stays active for the 2312h **AO Error Reaction Delay** time, then an appropriate EMCY message will be added to object 1003h **Pre-Defined Error Field**. The application will react to the EMCY message as defined by object 1029h **Error Behaviour** at the sub-index corresponding to an Input Fault. Refer to section 3.2.4 and 3.2.13 for more information about objects 1003h and 1029h, including the complete list of EMCY messages.

Once the absolute difference between the target and feedback FV comes back with the tolerance defined in 2311h, the error flag is cleared. This means that when the output is commanded off, the flags are automatically reset, since the target and feedback are now both zero.

1.6. PID Control Function Block

The PID control (PID) function blocks are not used by default.

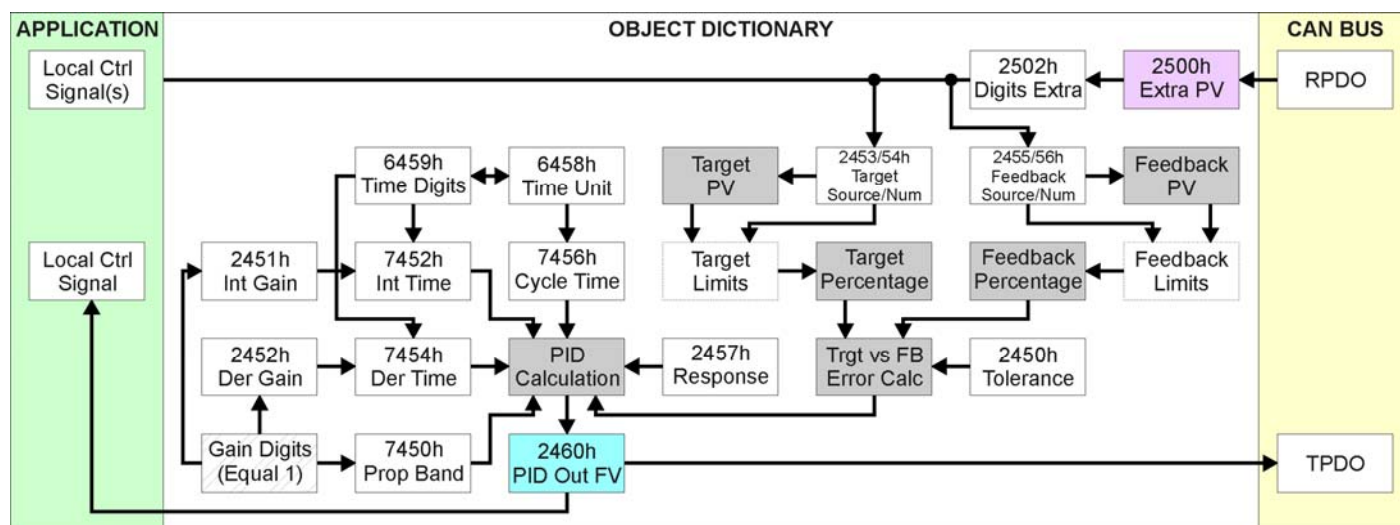

Figure 14 – PID Control Objects

As with the analog output block, the PID control function has control inputs associate with it that can be mapped to the output from any other function block. Objects 2453h **PID Target Source** and 2454h **PID Target Number** define what value the PID loop will attempt to maintain. For example, in the case of a setpoint (fixed) control application, this input can be mapped to one of object 5010h, a Constant FV. In this case, since there is no pre-defined range associate with a constant (see Table 17), the scaling limits will be set equal to those of the feedback input. Otherwise, the target input units do not have to match the feedback units, so long as they are scaled relative to one another.

Objects 2355h **PID Feedback Source** and 2356h **PID Feedback Number** define the close-loop input. Both the target and feedback use Tables 15 and 16 as the available options. Both inputs are normalized to a percentage based on the associated scaling limits as defined in Table 17.

Object 2450h **PID Tolerance** defines the acceptable difference between the target and feedback, as a percentage, whereby an absolute difference smaller than this is treated as a 0% error.

Unless both the target and feedback inputs have legitimate control sources selected, the PID loop is disabled. When active, however, the PID algorithm will be called every 7456h **PID Cycle Time**, the default being every 10ms.

Object 6458h **PID Physical Unit Timing** is a read-only value and is defined in Seconds. The default value for object 6459h **PID Decimal Digits Timing** is 3, which means the object 7456h, along with other PID timing objects, are interpreted in milliseconds. Other time objects associated with the PID control are 7452h **PID Integral Action Time (Ti)** and 7454h **PID Derivative Action Time (Td)**.

None time related objects use a fixed resolution of 1 decimal digit. These objects include 7450h **PID Proportional Band (G)**, 2450h **PID Tolerance**, 2451h **PID Integral Gain (Ki)**, and 2454h **PID Derivative Gain (Kd)**.

By default, the PID loop is assumed to be controlling a single output which will increase/decrease as the feedback over/undershoots the target. However, some systems may require a push-pull response where one output comes on when over target, and the other when under. Object 2457h **PID Control Response** allows the user to select the response profile as needed from Table 23.

Value	Meaning
0	Single Output
1	On When Over Target
2	On When Below Target

Table 23 – PID Control Response Options

The PID algorithm used is shown below, with names in red being the object variables. The result $PIDOutput_k$ is written to the read-only mappable object 2460h **PID Output Field Value**, and is interpreted as a percentage value with 1 decimal place resolution. It can be used as the control source for another function block, i.e. one of the analog outputs.

$$T = Loop_Update_Rate * 0.001$$

$$P_Gain = G$$

$$I_Gain = G * Ki * T / Ti$$

$$D_Gain = G * Kd * Td / T$$

Note: If Ti is zero, I_Gain = 0

$$Error_k = Target - Feedback$$

$$ErrorSum_k = ErrorSum_{k-1} + Error_k$$

$$P_k = Error_k * P_Gain$$

$$I_k = ErrorSum_k * I_Gain$$

$$D_k = (Error_k - Error_{k-1}) * D_Gain$$

$$PIDOutput_k = P_k + I_k + D_k$$

Figure 15 – PID Control Algorithm

Each system will have to be tuned for the optimum output response. Response times, overshoots and other variables will have to be decided by the customer using an appropriate PID tuning strategy.

1.7. Lookup Table Function Block

The lookup table (LTz) function blocks are not used by default.

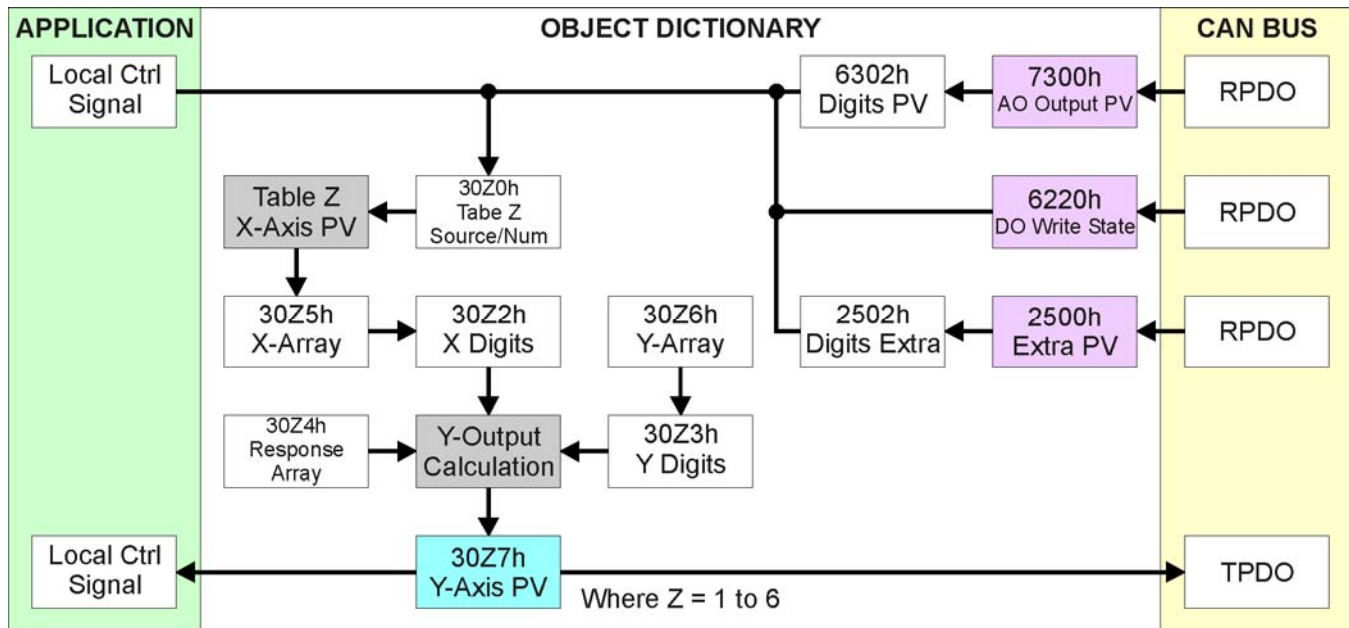

Figure 16 – Lookup Table Objects

Lookup tables are used to give an output response of up to 10 slopes per input. The array size of the objects 30z4h LTz Point Response, 30z5h LTz Point X-Axis PV and 30z6h Point Y-Axis PV shown in the block diagram above is therefore 11.

Note: If more than 10 slopes are required, a Logic Block can be used to combine up to three tables to get 30 slopes, as is described in Section 1.8.

There are two key parameters that will affect how this function block will behave. The objects 30z0h **Lookup Table z Input X-Axis Source** and 30z1h **Lookup Table z Input X-Axis Number** together define the control source for the function block. When it is changed, the table the values in object 30z5h need to be updated with new defaults based on the X-Axis source selected as described in Tables 15 and 16.

The second parameter that will affect the function block, is object **30z4h sub-index 1** which defines the “**X-Axis Type**”. By default, the tables have a ‘*Data Response*’ output (0). Alternatively, it can be selected as a ‘*Time Response*’ (1), which is described later in Section 1.7.4.

1.7.1. X-Axis, Input Data Response

In the case where the “**X-Axis Type**” = ‘*Data Response*’, the points on the X-Axis represents the data of the control source.

For example, if the control source is a Universal Input, setup as a 0-5V type, with an operating range of 0.5V to 4.5V. Object 30z2h **LTz X-Axis Decimal Digits PV** should be set to match that of object 2102 **AI Decimal Digits FV**. The X-Axis could be setup to have a “**LTz Point X-Axis PV sub-index 2**” of 500, and setpoint “**LTz Point X-Axis PV sub-index 11**” will be set to 4500. The first point “**LTz Point X-Axis PV sub-index 1**” should start from 0 in this case.

For most 'Data Responses', the default value at point (1,1) is [0,0].

However, should the minimum input be less than zero, for example a resistive input that is reflecting temperature in the range of -40°C to 210°C, then the "LTz Point X-Axis PV sub-index 1" will be set to the minimum instead, in this case -40°C.

The constraint on the X-Axis data is that the next index value is greater than or equal to the one below it, as shown in the equation below. Therefore, when adjusting the X-Axis data, it is recommended that X₁₁ is changed first, then lower indexes in descending order.

$$\text{MinInputRange} \leq X_1 \leq X_2 \leq X_3 \leq X_4 \leq X_5 \leq X_6 \leq X_7 \leq X_8 \leq X_9 \leq X_{10} \leq X_{11} \leq \text{MaxInputRange}$$

As stated earlier, MinInputRange and MaxInputRange will be determined by the scaling objects associated with X-Axis Source that has been selected, as outlined in Table 17.

1.7.2. Y-Axis, Lookup Table Output

By default, it is assumed that the output from the lookup table function block will be a percentage value in the range of 0 to 100.

In fact, so long as all the data in the Y-Axis is $0 \leq Y[i] \leq 100$ (where $i = 1$ to 11) then other function blocks using the lookup table as a control source will have 0 and 100 as the Scaling 1 and Scaling 2 values used in linear calculations shown in Table 17.

However, the Y-Axis has no constraints on the data that it represents. This means that inverse, or increasing/decreasing or other responses can be easily established. **The Y-Axis does not have to be a percentage output, but could represent full scale process values instead.**

For example, should the X-Axis of a table be a resistive value (as read from an analog input), the output of the table could be temperature from an NTC sensor in the range $Y_1 = 125^\circ\text{C}$ to $Y_{11} = -20^\circ\text{C}$. If this table is used as the control source for another function block (i.e. feedback to a PID control), then Scaling 1 would be -20 and Scaling 2 would be 125 when used in a linear formula.

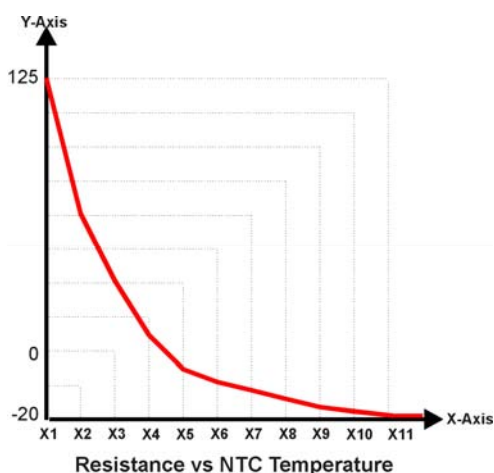

Figure 17 – Lookup Table Example Resistance vs. NTC Temperature

In all cases, the controller looks at the **entire range** of the data in the Y-Axis sub-indexes, and selects the lowest value as the MinOutRange and the highest value as the MaxOutRange. So long as they are not both within the 0 to 100 range, they are passed directly to other function blocks as the limits on the lookup table output. (i.e Scaling 1 and Scaling 2 values in linear calculations.)

Even if some of the data points are *Ignored* as described in Section 1.7.3, they are still used in the Y-Axis range determination. If not all the data points are going to be used, it is recommended that Y10 be set to the minimum end of the range, and Y11 to the maximum first. This way, the user can get predictable results when using the table to drive another function block, such as an analog output.

1.7.3. Point To Point Response

By default, all six lookup tables have a simple linear response from 0 to 100 in steps of 10 for both the X and Y axes. For a smooth linear response, each point in the 30z4h **LTz Point Response** array is setup for a *Ramp To* output.

Alternatively, the user could select a *Step To* response for 30z4h, where N = 2 to 11. In this case, any input value between X_{N-1} to X_N will result in an output from the lookup table function block of Y_N . (Recall: *LTz Point Response sub-index 1 defines the X-Axis type*)

Figure 18 shows the difference between these two response profiles with the default settings.

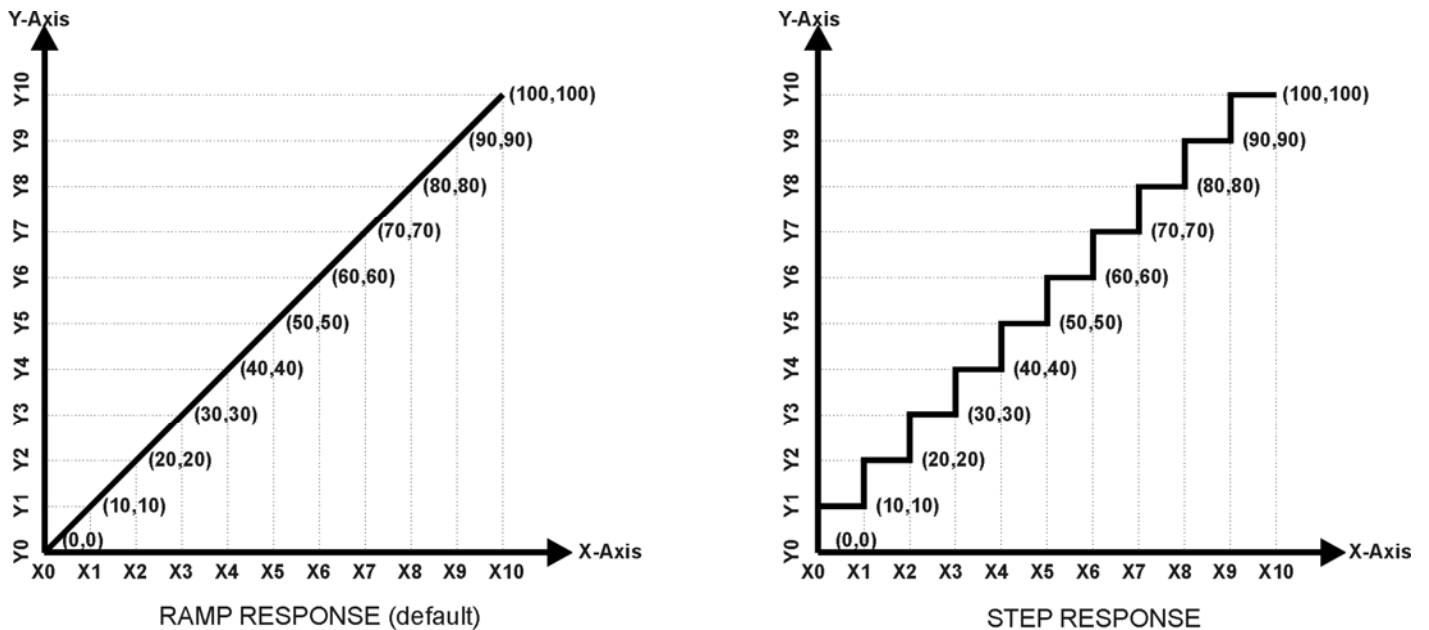

Figure 18 – Lookup Table Defaults with Ramp and Step Responses

Lastly, any point except (1,1) can be selected for an *Ignore* response. If **LTz Point Response sub-index N** is set to ignore, then all points from (X_N, Y_N) to (X_{11}, Y_{11}) will also be ignored. For all data greater than X_{N-1} , the output from the lookup table function block will be Y_{N-1} .

A combination of *Ramp To*, *Jump To* and *Ignore* responses can be used to create an application specific output profile. An example of where the same input is used as the X-Axis for two tables, but where the output profiles *mirror* each other for a deadband joystick response is shown in Figure 19. The example shows a dual slope percentage output response for each side of the deadband, but additional slopes can be easily added as needed. (Note: *In this case, since the analog outputs are responding directly to the profile from the lookup tables, both would have object 2342h AO Control Response set to a 'Single Output Profile.'*)

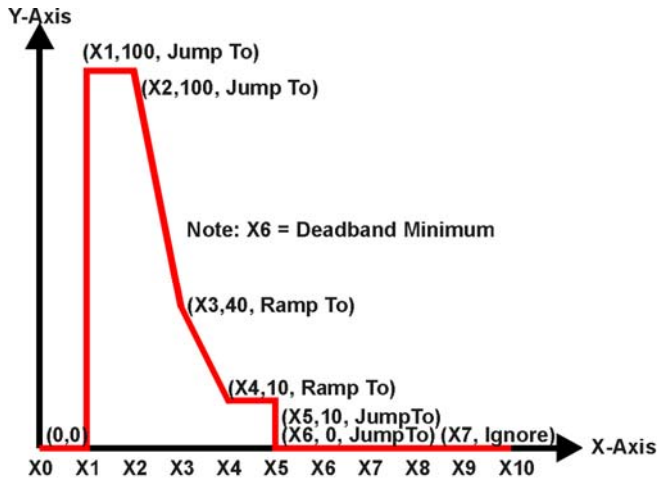

Figure A - Dual Slope "Profile B"
Joystick Deadband Response

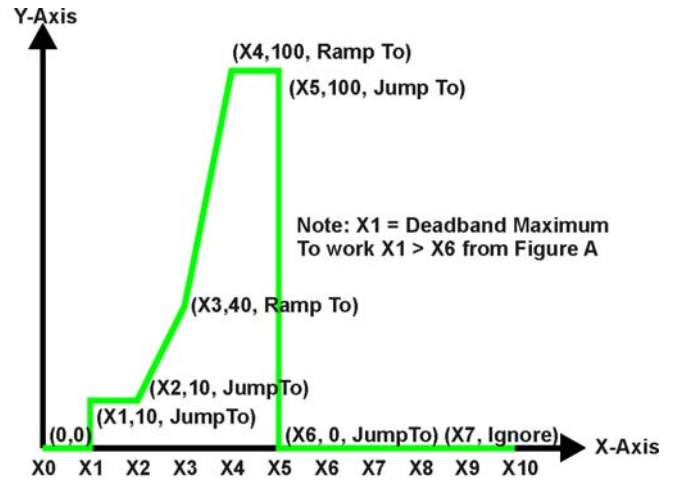

Figure B - Dual Slope "Profile A"
Joystick Deadband Response

Figure 19 – Lookup Table Examples to Setup for Dual-Slope Joystick Deadband Response

To summarize, Table 24 outlines the different responses that can be selected for object 30z4h, both for the X-Axis type and for each point in the table.

Sub-Index	Value	Meaning
1	0	Data Response (X-Axis Type)
2 to 11		Ignore (this point and all following it)
1	1	Time Response (X-Axis Type)
2 to 11		Ramp To (this point)
1	2	N/A (not an allowed option)
2 to 11		Jump To (this point)

Table 24 – LTz Point Response Options

1.7.4. X-Axis, Time Response

As mentioned in Section 1.5, a lookup table can also be used to get a custom output response where the “**X-Axis Type**” is a *Time Response*. When this is selected, the X-Axis now represents time, in units of milliseconds, while the Y-Axis still represents the output of the function block.

In this case, the X-Axis control source is treated as a digital input. If the signal is actually an analog input, it is interpreted like a digital input per Figure 5. When the control input is ON, the output will be changed over a period of time based on the profile in the lookup table. Once the profile has finished (i.e. reached index 11, or an *Ignored* response), the output will remain at the last output at the end of the profile until the control input turns OFF.

When the control input is OFF, the output is always at zero. When the input come ON, the profile ALWAYS starts at position (X₁, Y₁) which is 0 output for 0ms.

When using the lookup table to drive an output based on **time**, it is mandatory that objects 2330h **Ramp Up** and 2331h **Ramp Down** in the analog output function block be set to **zero**. Otherwise, the output result will not match the profile as expected. Recall, also, that the AO scaling should be set to match the Y-Axis scaling of the table in order to get a 1:1 response of AO Output FV versus LTz Output Y-Axis PV.

An application where the time response feature would be useful is filling a clutch when a transmission is engaged. An example of some fill profiles is shown in Figure 20.

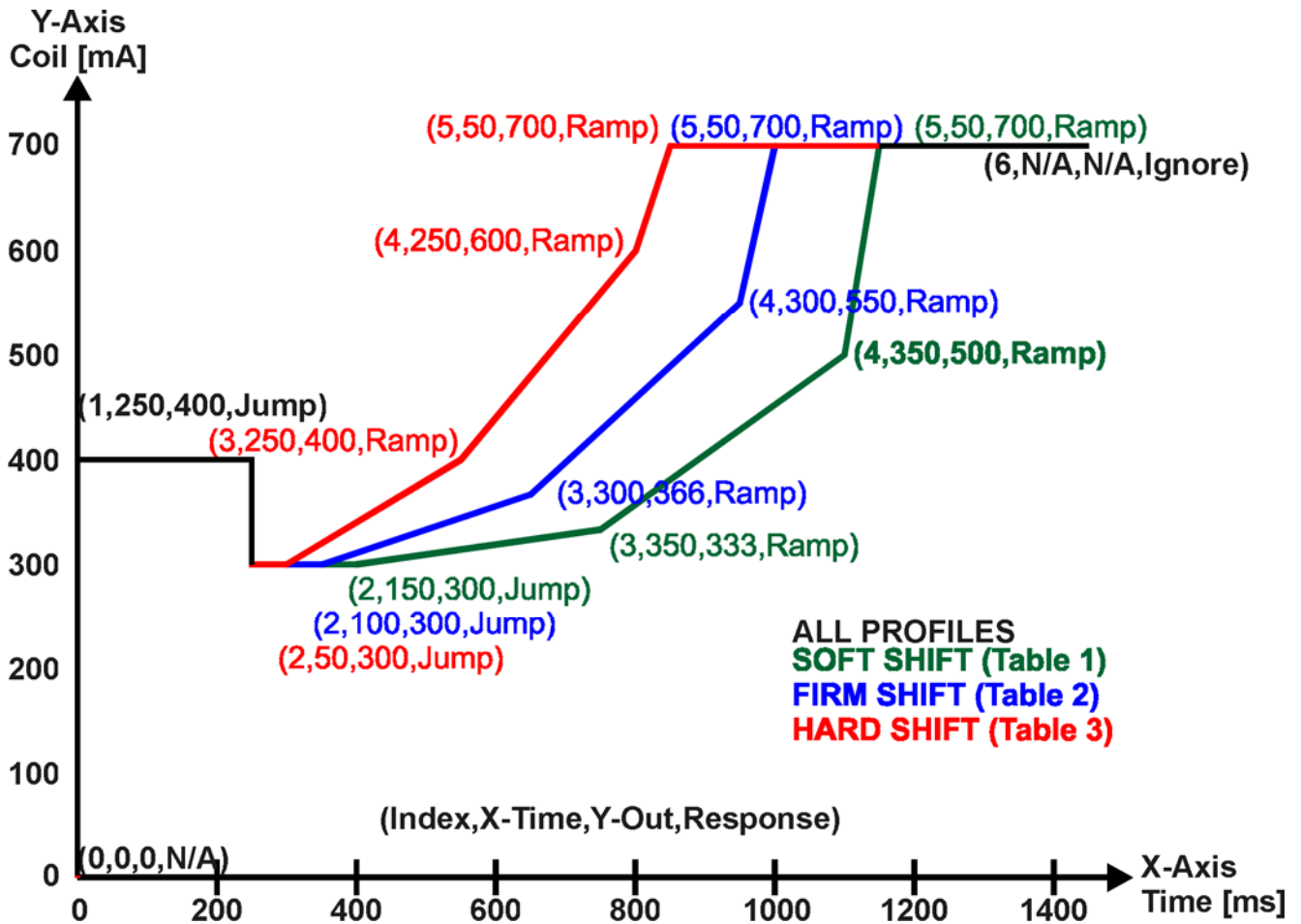

Figure 20 – Lookup Table Time Response Clutch Fill Profiles

In a time response, the data in object 30z5h LTz Point X-Axis PV is measured in milliseconds, and object 30z2h LTz X-Axis Decimal Digits PV is automatically set to 0. A minimum value of 1ms must be selected for all points other than sub-index 1 which is automatically set to [0,0]. The interval time between each point on the X-axis can be set anywhere from 1ms to 24 hours. [86,400,000 ms]

1.7.5. Lookup Table Final Note

One final note about the lookup tables is that if a digital input is selected as the control source for the X-Axis, only a 0 (Off) or 1 (On) will be measured. Ensure that the data range for the X-Axis on the table is updated appropriately in this condition.

1.8. Programmable Logic Function Block

The programmable logic block (LBx) functions are not used by default.

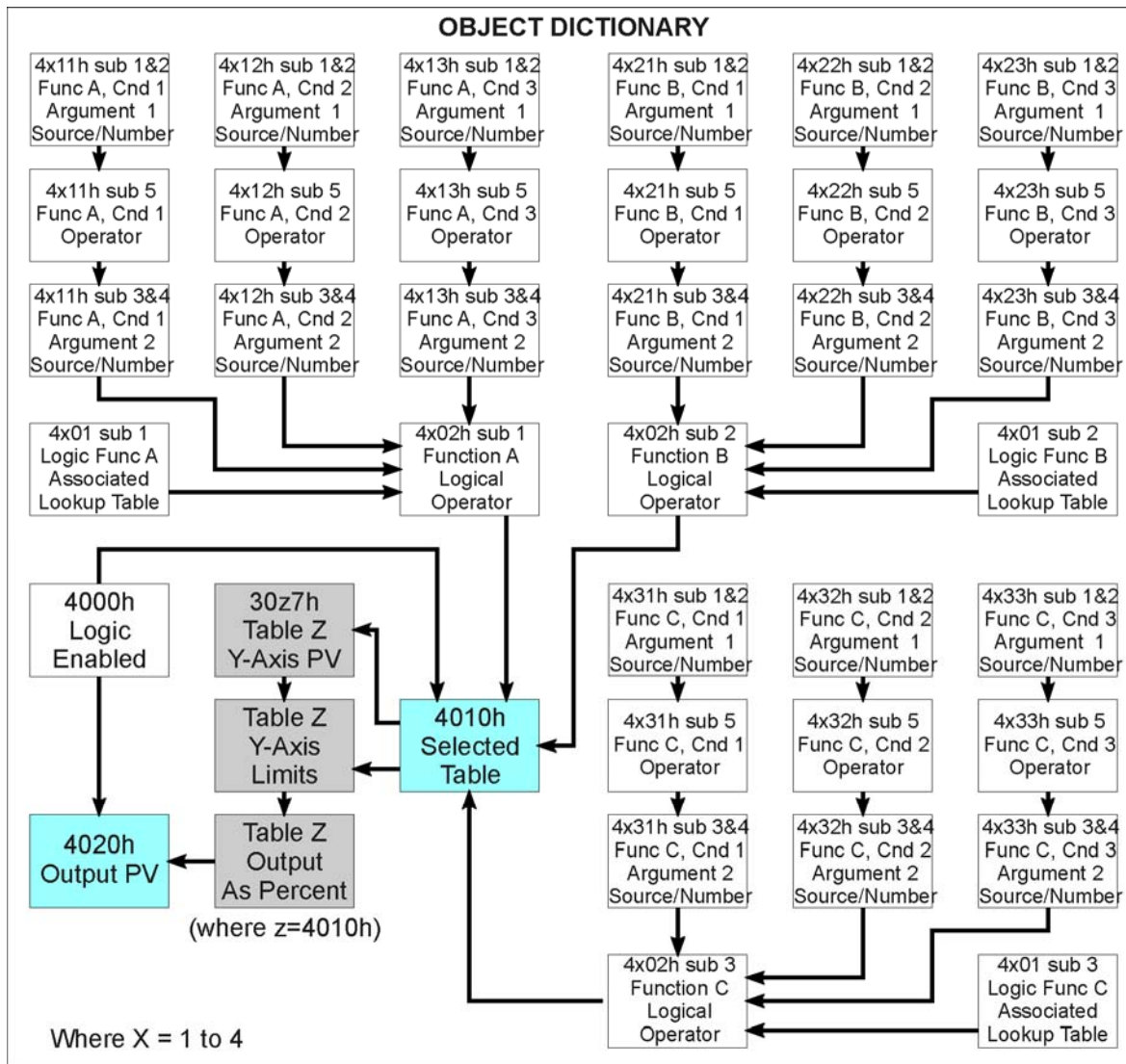

Figure 21 – Logic Block Objects

This function block is obviously the most complicated of them all, but very powerful. Any LBx (where X=1 to 4) can be linked with up to three lookup tables, any one of which would be selected only under given conditions. Any three tables (of the available 6) can be associated with the logic, and which ones are used is fully configurable on object 4x01 **LBx Lookup Table Number**.

Should the conditions be such that a particular table (A, B or C) has been selected as described in Section 1.8.2, then the output from the selected table, at any given time, will be passed directly to LBx's corresponding sub-index X in read-only mappable object 4020h **Logic Block Output PV**. The active table number can read from read-only object 4010h **Logic Block Selected Table**.

Therefore, an LBx allows up to three different responses to the same input, or three different responses to different inputs, to become the control for another function block, such as an analog output. Here, the **“Control Source”** for the reactive block would be selected to be the *‘Programmable Logic Function Block,’* as described in Section 1.5.

In order to enable any one of logic blocks, the corresponding sub-index in object 4000h **Logic Block Enable** must be set to TRUE. They are all disabled by default.

Logic is evaluated in the order shown in Figure 22. Only if a lower indexed table (A, B, C) has not been selected will the conditions for the next table be looked at. **The default table is always selected as soon as it is evaluated. It is therefore required that the default table always be the highest index in any configuration.**

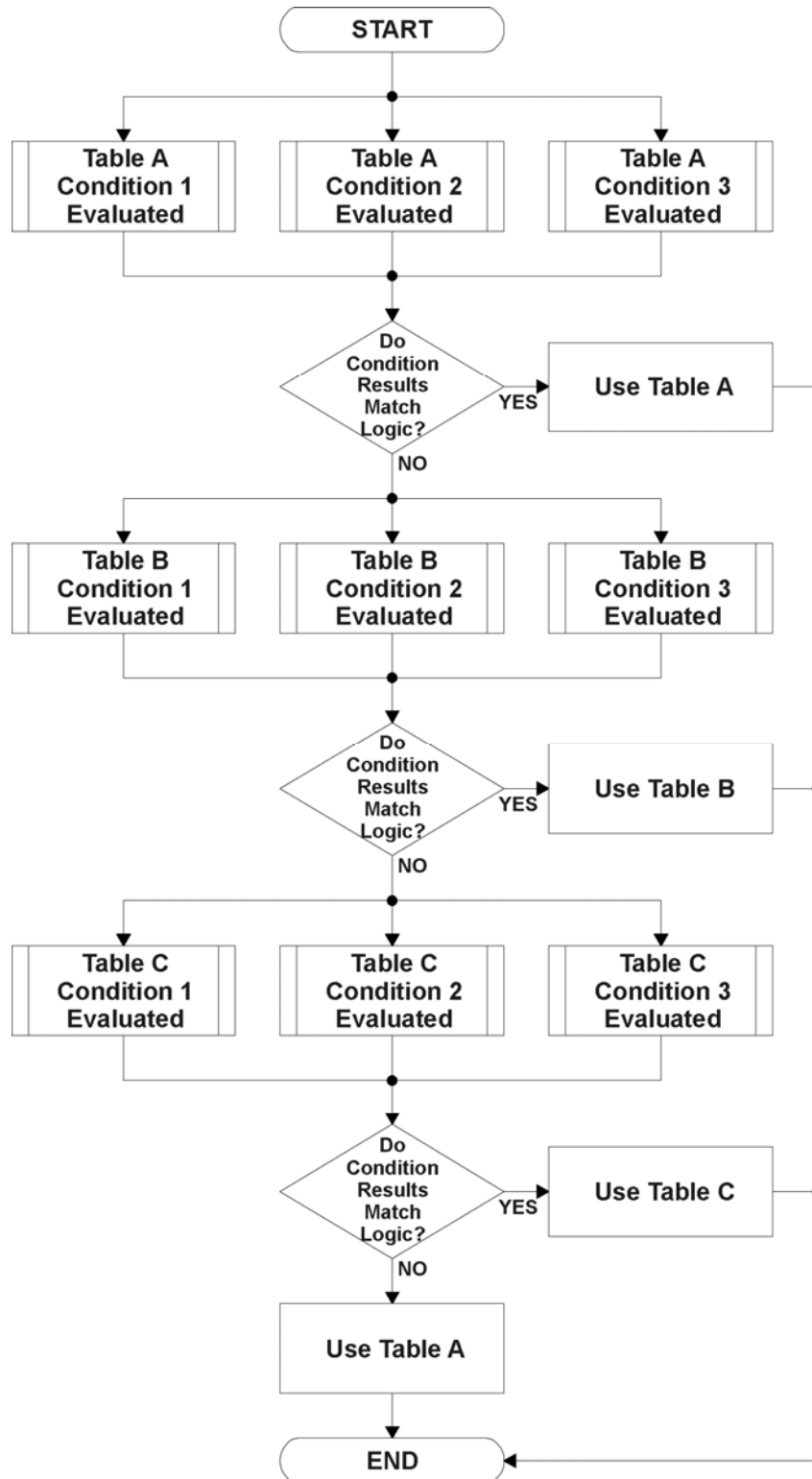

Figure 22 – Logic Block Flowchart

1.8.1. Conditions Evaluation

The first step in determining which table will be selected as the active table is to first evaluate the conditions associated with a given table. Each table has associated with it up to three conditions that can be evaluated. Conditional objects are custom DEFSTRUCT objects defined as shown in Table 25.

Index	Sub-Index	Name	Data Type
4xyz*	0	Highest sub-index supported	UNSIGNED8
	1	Argument 1 Source	UNSIGNED8
	2	Argument 1 Number	UNSIGNED8
	3	Argument 2 Source	UNSIGNED8
	4	Argument 2 Number	UNSIGNED8
	5	Operator	UNSIGNED8

* Logic Block X Function Y Condition Z, where X = 1 to 4, Y = A, B or C, and Z = 1 to 3

Table 25 – LBx Condition Structure Definition

Objects 4x11h, 4x12h and 4x13h are the conditions evaluated for selecting Table A. Objects 4x21h, 4x22h and 4x23h are the conditions evaluated for selecting Table B. Objects 4x31h, 4x32h and 4x33h are the conditions evaluated for selecting Table C.

Argument 1 is always a logical output from another function block, as listed in Table 15. As always, the input is a combination of the functional block objects 4xyzh sub-index 1 “**Argument 1 Source**” and “**Argument 1 Number.**”

Argument 2 on the other hand, could either be another logical output such as with Argument 1, OR a constant value set by the user. To use a constant as the second argument in the operation, set “**Argument 2 Source**” to ‘Constant Function Block’, and “**Argument 2 Number**” to the desired sub-index. When defining the constant, make sure it uses the same resolution (decimal digits) as the Argument 1 input.

Argument 1 is evaluated against Argument 2 based on the “**Operator**” selected in sub-index 5 of the condition object. The options for the operator are listed in Table 26, and the default value is always ‘Equal’ for all condition objects.

Value	Meaning
0	=, Equal
1	!=, Not Equal
2	>, Greater Than
3	>=, Greater Than or Equal
4	<, Less Than
5	<=, Less Than or Equal

Table 26 – LBx Condition Operator Options

For example, a condition for a transmission control shift selection, as shown in Figure 20 in the previous section, could be that the Engine RPM be less than a certain value to select a Soft Fill profile. In this case, “**Argument 1 Source**” could be set to ‘Analog Input Function Block’ (where the input is configured for RPM pickup), “**Argument 2 Source**” to ‘Constant Function Block’, and the “**Operator**” to ‘<, Less Than.’ Object 5010h Constant FV at sub-index “**Argument 2 Number**” would be set to whatever cutoff RPM the application required.

By default, both arguments are set to 'Control Source Not Used' which disables the condition, and automatically results in a value of N/A as the result. Although is generally considered that each condition will be evaluated as either TRUE or FALSE, the reality is that there could be four possible results, as described in Table 27.

Value	Meaning	Reason
0	False	(Argument 1) Operator (Argument 2) = False
1	True	(Argument 1) Operator (Argument 2) = True
2	Error	Argument 1 or 2 output was reported as being in an error state
3	Not Applicable	Argument 1 or 2 is not available (i.e. set to 'Control Source Not Used')

Table 27 – LBx Condition Evaluation Results

1.8.2. Table Selection

In order to determine if a particular table will be selected, logical operations are performed on the results of the conditions as determined by the logic in Section 1.8.1. There are several logical combinations that can be selected, as listed in Table 28. The default value for object 4x02h **LBx Function Logical Operator** is dependent on the sub-index. For sub-index 1 (Table A) and 2 (Table B), the 'Cnd1 And Cnd2 And Cnd3' operator is used, whereas sub-index 3 (Table C) is setup as the 'Default Table' response.

Value	Meaning
0	Default Table
1	Cnd1 And Cnd2 And Cnd3
2	Cnd1 Or Cnd2 Or Cnd3
3	(Cnd1 And Cnd2) Or Cnd3
4	(Cnd1 Or Cnd2) And Cnd3

Table 28 – LBx Function Logical Operator Options

Not every evaluation is going to need all three conditions. The case given in the earlier section, for example, only has one condition listed, i.e. that the Engine RPM be below a certain value. Therefore, it is important to understand how the logical operators would evaluate an Error or N/A result for a condition, as outlined in Table 29.

Logical Operator	Select Conditions Criteria
Default Table	Associated table is automatically selected as soon as it is evaluated.
Cnd1 And Cnd2 And Cnd3	<p>Should be used when two or three conditions are relevant, and all must be True to select the table.</p> <p>If any condition equals False or Error, the table is not selected. An N/A is treated like a True. If all three conditions are True (or N/A), the table is selected.</p> <p>If((Cnd1==True) &&(Cnd2==True)&&(Cnd3==True)) Then Use Table</p>
Cnd1 Or Cnd2 Or Cnd3	<p>Should be used when only one condition is relevant. Can also be used with two or three relevant conditions.</p> <p>If any condition is evaluated as True, the table is selected. Error or N/A results are treated as False</p> <p>If((Cnd1==True) (Cnd2==True) (Cnd3==True)) Then Use Table</p>

(Cnd1 And Cnd2) Or Cnd3	<p>To be used only when all three conditions are relevant.</p> <p>If both Condition 1 and Condition 2 are True, OR Condition 3 is True, the table is selected. Error or N/A results are treated as False</p> <p>If(((Cnd1==True)&&(Cnd2==True)) (Cnd3==True)) Then Use Table</p>
(Cnd1 Or Cnd2) And Cnd3	<p>To be used only when all three conditions are relevant.</p> <p>If Condition 1 And Condition 3 are True, OR Condition 2 And Condition 3 are True, the table is selected. Error or N/A results are treated as False</p> <p>If(((Cnd1==True) ((Cnd2==True)) && (Cnd3==True)) Then Use Table</p>

Table 29 – LBx Conditions Evaluation Based on Selected Logical Operator

If the result of the function logic is TRUE, then the associated lookup table (see object 4x01h) is immediately selected as the source for the logic output. No further conditions for other tables are evaluated. For this reason, the ‘Default Table’ should always be setup as the highest letter table being used (A, B or C) If no default response has been setup, the Table A automatically becomes the default when no conditions are true for any table to be selected. This scenario should be avoided whenever possible so as to not result in unpredictable output responses.

The table number that has been selected as the output source is written to sub-index X of read-only object 4010h **Logic Block Selected Table**. This will change as different conditions result in different tables being used.

1.8.3. Logic Block Output

Recall that Table Y, where Y = A, B or C in the LBx function block does NOT mean lookup table 1 to 3. Each table has object 4x01h LBx **Lookup Table Number** which allows the user to select which lookup tables they want associated with a particular logic block. The default tables associated with each logic block are listed in Table 30.

Programmable Logic Block Number	Table A – Lookup Table Block Number	Table B – Lookup Table Block Number	Table C – Lookup Table Block Number
1	1	2	3
2	4	5	6
3	1	2	3
4	4	5	6

Table 30 – LBx Default Lookup Tables

If the associated Lookup Table Z (where Z equals 4010h sub-index X) does not have an “X-Axis Source” selected, then the output of LBx will always be “Not Available” so long as that table is selected. However, should LTz be configured for a valid response to an input, be it Data or Time, the output of the LTz function block (i.e. the Y-Axis data that has been selected based on the X-Axis value) will become the output of the LBx function block so long as that table is selected.

The LBx output is always setup as a percentage, based on the range of the Y-Axis for the associated table (see Section 1.7.2) It is written to sub-index X of read-only object 4020h **Logic Block Output PV** with a resolution of 1 decimal place.

1.8.4. Application Ideas

This section is not meant to be a comprehensive list of all the possibilities that the Logic Block offers. Rather, it is meant to show how some common, but widely diversified functions can be achieved by using it.

- a) Dual Speed Application – Under certain conditions, an analog output could be driven between Min_A to Max_A while under others, the speed is limited by having the output respond to changes at the input between Min_B and Max_B.
- b) Multi-Speed Transmission Control – By using a Forward input as the enable of one analog output, and the Reverse input as the other, different clutch fill profiles could be selected based on Engine Speed as discussed in earlier examples.
- c) Getting better resolution (i.e. up to 30 slopes) on a resistive to temperature curve for an NTC sensor. The condition for Table A would be input resistance $\leq R_1$, Table B is input $\leq R_2$ and Table C as the default for high resistance values.

1.9. Miscellaneous Function Block

There are some other objects available which have not yet been discussed, or mentioned briefly in passing (i.e. constants.) These objects are not necessarily associated with one another, but are all discussed here.

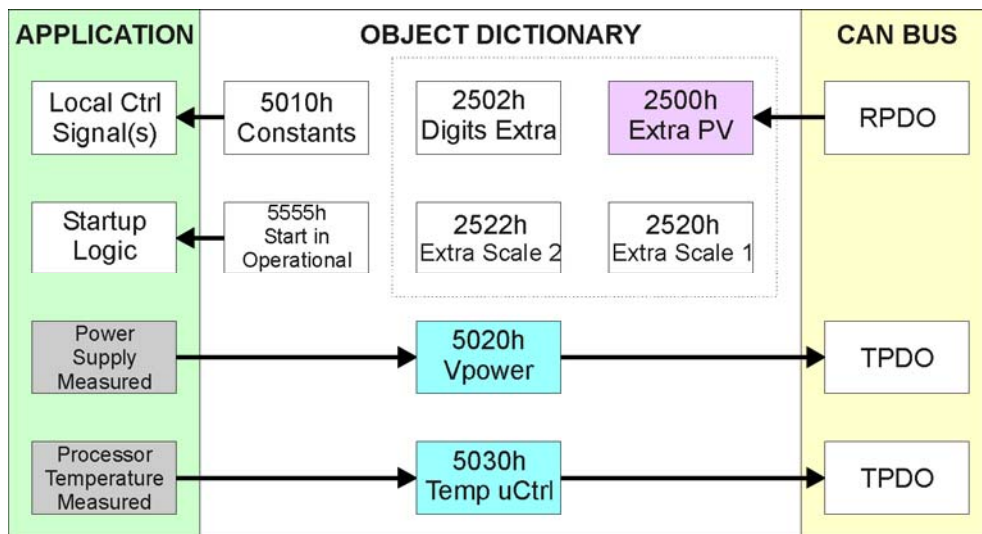

Figure 23 – Miscellaneous Objects

Objects 2500h **Extra Control Received PV**, 2502h **EC Decimal Digits PV**, 2502h **EC Scaling 1 PV** and **EC Scaling 2 PV** have been mentioned in Section 1.5, Table 16. These objects allow for additional data received on a CANopen® RPDO to be mapped independently to various function blocks as a control source. For example, a PID loop must have two inputs (target and feedback), so one of them has to come from the CAN bus. The scaling objects are provided to define the limits of the data when it is used by another function block, as shown in Table 17.

Objects 5020h **Power Supply FV** and 5030h **Processor Temperature FV** are available as read-only feedback for additional diagnostics.

Object 5010h **Constant Field Value** is provided to give the user the option for a fixed value that can be used by other function blocks. Sub-index 1 is fixed as FALSE (0) and sub-index 2 is always TRUE (1). There are 4 other sub-indexes provided for user selectable values. (Defaults 25, 50, 75 and 100)

The constants are read as 32-bit real (float) data, so no decimal digit object is provided. When setting up the constant, make sure to do it with the resolution of the object that will be compared with it.

The False/True constants are provided primarily to be used with the logic block. The variable constants are also useful with the logic block, and they can also be used as a setpoint target for a PID control block.

The last object 5555h **Start in Operational** is provided as a 'cheat' when the unit is not intended to work with a CANopen network (i.e. a stand-alone control), or is working on a network comprised solely as slaves so the OPERATION command will never be received from a master. By default this object is disabled (FALSE).

When using the 1i2o as a stand-alone controller where 5555h is set to TRUE, it is recommended to disable all TPDOs (set the Event Timer to zero) so that it does not run with a continuous CAN error when not connected to a bus.

2. INSTALLATION INSTRUCTIONS

2.1. Dimensions and Pinout

The Single Input, Dual Output Valve Controller is packaged in an encapsulated aluminum enclosure, as shown in Figure 24. The assembly carries an IP67 rating.

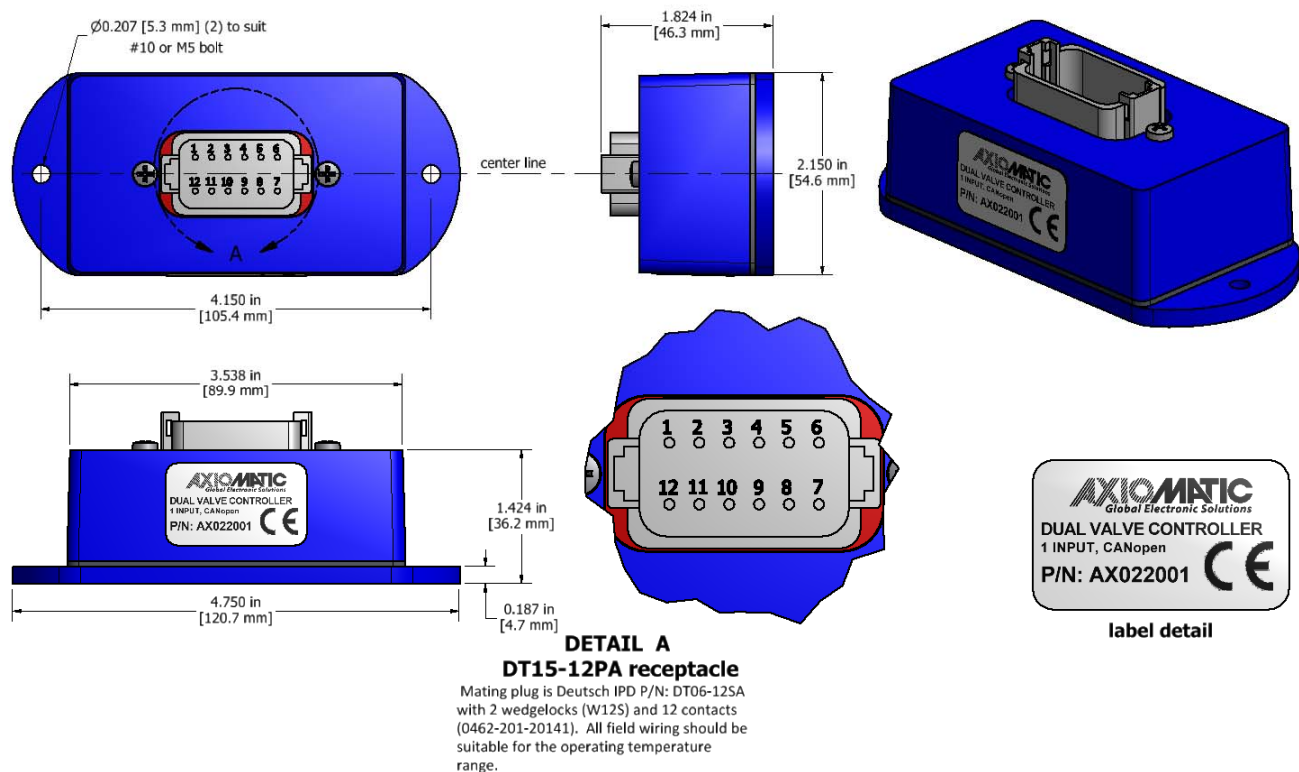

Figure 24 – Housing Dimensions

CAN and I/O Connector	
Pin #	Function
1	Analog Output 1 +
2	AO Ground 1
3	Power +
4	CAN Shield
5	CAN_L
6	CAN_H
7	+5V Reference (up to 10mA)
8	AI Ground 1
9	Analog Input 1
10	Power GND
11	AO Ground 2
12	Analog Output 2 +

Table 31 – Connector Pinout

12 pin Deutsch IPD connector P/N: DT15-12PA

A mating plug kit is available as Axiomatic P/N: **AX070105**.

Contents of kit include: DT06-12SA, W12S, 12 pieces of 0462-201-16141, 3 plugs

2.2. Installation Instructions

NOTES & WARNINGS

- Do not install near high-voltage or high-current devices.
- Ground the chassis for safety purposes and proper EMI shielding.
- Note the operating temperature range. All field wiring must be suitable for that temperature range.
- Install the unit with appropriate space available for servicing and for adequate wire harness access (15 cm) and strain relief (30 cm).
- Do not connect or disconnect the unit while the circuit is live, unless the area is known to be non-hazardous.

MOUNTING

The module is designed for mounting on the valve block. If it is mounted without an enclosure, the controller should be mounted horizontally with connectors facing left or right, or with the connectors facing down, to reduce likelihood of moisture entry.

Mask all labels if the unit is to be repainted, so label information remains visible.

Mounting legs include holes sized for #10 or M4.5 bolts. The bolt length will be determined by the end-user's mounting plate thickness. Typically 20 mm (3/4 inch) is adequate.

If the module is mounted away from the valve block, no wire or cable in the harness should exceed 30 meters in length. The power input wiring should be limited to 10 meters.

CONNECTIONS

Use the following Deutsch IPD mating plugs to connect to the integral receptacles. Wiring to these mating plugs must be in accordance with all applicable local codes. Suitable field wiring for the rated voltage and current must be used. The rating of the connecting cables must be at least 85°C. For ambient temperatures below -10°C and above +70°C, use field wiring suitable for both minimum and maximum ambient temperature.

Receptacle	Mating Sockets as appropriate (Refer to www.laddinc.com for more information on the contacts available for this mating plug.)
Mating Connector	DT06-12SA and wedge W12S

NOISE – ELECTRICAL CONNECTIONS AND SHIELDING

To reduce noise, separate all power and output wires from those of the input and CAN. Shielded wires will protect against injected noise. Shield wires should be connected at the power or input source, or at the output load.

The CAN shield can be connected at the controller using the CAN Shield pin provide on the connector. However the other end should not be connected in this case.

All wires used must be 16 or 18 AWG.

CAN NETWORK CONSTRUCTION

Axiomatic recommends that multi-drop networks be constructed using a “daisy chain” or “backbone” configuration with short drop lines.

CAN TERMINATION

It is necessary to terminate the network; therefore an external CAN termination is required. No more than two network terminators should be used on any one single network. A terminator is a 121 Ω , 0.25 W, 1% metal film resistor placed between CAN_H and CAN_L terminals at the end two nodes on a network.

3. CANOPEN ® OBJECT DICTIONARY

The CANopen object dictionary of the 1i2o Controller is based on CiA device profile DS-404 V1.2 (device profile for Closed Loop Controllers). The object dictionary includes Communication Objects beyond the minimum requirements in the profile, as well as several manufacturer-specific objects for extended functionality.

3.1. NODE ID and BAUDRATE

By default, the 1i2o Controller ships factory programmed with a Node ID = 127 (0x7F) and with Baudrate = 125 kbps.

3.1.1. LSS Protocol to Update

The only means by which the Node-ID and Baudrate can be changed is to use Layer Settling Services (LSS) and protocols as defined by CANopen ® standard DS-305.

Follow the steps below to configure either variable using LSS protocol. If required, please refer to the standard for more detailed information about how to use the protocol.

3.1.1.1. Setting Node-ID

- Set the module state to LSS-configuration by **sending** the following message:

<i>Item</i>	<i>Value</i>
COB-ID	0x7E5
Length	2
Data 0	0x04 (cs=4 for switch state global)
Data 1	0x01 (switches to configuration state)

- Set the Node-ID by **sending** the following message:

<i>Item</i>	<i>Value</i>
COB-ID	0x7E5
Length	2
Data 0	0x11 (cs=17 for configure node-id)
Data 1	Node-ID (set new Node-ID as a hexadecimal number)

- The module will send the following response (any other response is a failure):

<i>Item</i>	<i>Value</i>
COB-ID	0x7E4
Length	3
Data 0	0x11 (cs=17 for configure node-id)
Data 1	0x00
Data 2	0x00

- Save the configuration by **sending** the following message:

<i>Item</i>	<i>Value</i>
COB-ID	0x7E5
Length	1
Data 0	0x17 (cs=23 for store configuration)

- The module will send the following response (any other response is a failure):

<i>Item</i>	<i>Value</i>
COB-ID	0x7E4
Length	3
Data 0	0x17 (cs=23 for store configuration)
Data 1	0x00
Data 2	0x00

- Set the module state to LSS-operation by **sending** the following message:
(Note, the module will reset itself back to the pre-operational state)

<i>Item</i>	<i>Value</i>
COB-ID	0x7E5
Length	2
Data 0	0x04 (cs=4 for switch state global)
Data 1	0x00 (switches to waiting state)

3.1.1.2. Setting Baudrate

- Set the module state to LSS-configuration by **sending** the following message:

<i>Item</i>	<i>Value</i>
COB-ID	0x7E5
Length	2
Data 0	0x04 (cs=4 for switch state global)
Data 1	0x01 (switches to configuration state)

- Set the baudrate by **sending** the following message:

<i>Item</i>	<i>Value</i>
COB-ID	0x7E5
Length	3
Data 0	0x13 (cs=19 for configure bit timing parameters)
Data 1	0x00 (switches to waiting state)
Data 2	Index (select baudrate index per table 32)

Index	Bit Rate
0	1 Mbit/s
1	800 kbit/s
2	500 kbit/s
3	250 kbit/s
4	125 kbit/s (default)
5	reserved (100 kbit/s)
6	50 kbit/s
7	20 kbit/s
8	10 kbit/s

Table 32 – LSS Baudrate Indexes

- The module will send the following response (any other response is a failure):

Item	Value
COB-ID	0x7E4
Length	3
Data 0	0x13 (cs=19 for configure bit timing parameters)
Data 1	0x00
Data 2	0x00

- Activate bit timing parameters by **sending** the following message:

Item	Value
COB-ID	0x7E5
Length	3
Data 0	0x15 (cs=19 for activate bit timing parameters)
Data 1	<delay_lsb>
Data 2	<delay_msb>

The delay individually defines the duration of the two periods of time to wait until the bit timing parameters switch is done (first period) and before transmitting any CAN message with the new bit timing parameters after performing the switch (second period). The time unit of switch delay is 1 ms.

- Save the configuration by **sending** the following message (on the NEW baudrate):

Item	Value
COB-ID	0x7E5
Length	1
Data 0	0x17 (cs=23 for store configuration)

- The module will send the following response (any other response is a failure):

Item	Value
COB-ID	0x7E4
Length	3
Data 0	0x17 (cs=23 for store configuration)
Data 1	0x00
Data 2	0x00

- Set the module state to LSS-operation by **sending** the following message:
(Note, the module will reset itself back to the pre-operational state)

Item	Value
COB-ID	0x7E5
Length	2
Data 0	0x04 (cs=4 for switch state global)
Data 1	0x00 (switches to waiting state)

The following screen capture (left) shows the CAN data was sent (7E5h) and received (7E4h) by the tool when the baudrate was changed to 250 kbps using the LSS protocol. The other image (right) shows what was printed on an example debug RS-232 menu while the operation took place.

Between CAN Frame 98 and 99, the baudrate on the CAN Scope tool was changed from 125 to 250 kbps.

The left screenshot shows the Net0 CAN USB331 interface. The 'Add/Delete ID Area' section has 'from' and 'to' fields empty, and 'Add >' and '< Del' buttons. The 'Net:' dropdown is set to '0 - CAN_USB331' and the 'Baud rate:' dropdown is set to '250'. Below this is a table of CAN frames:

Fram...	Absolute Time	RelTime	Id	Atr	L	d1	d2	d3	d4
95	11:42:45.248	6110	07E5		2	04	01		
96	11:42:54.468	9219	07E5		3	13	00	03	
97	11:42:54.468	0	07E4		3	13	00	00	
98	11:42:58.687	4218	07E5		3	15	88	13	
99	11:43:16.579	17891	07E5		1	17			
100	11:43:16.907	328	07E4		3	17	00	00	
101	11:43:23.017	6109	07E5		2	04	00		
102	11:43:23.017	0	0750		1	00			

The right screenshot shows a debug RS-232 menu with the following text:

```

===== Main Menu =====
Choose one of the following:
U: View Object Dictionary
D: Default Object Dictionary
T: Toggle RS-232 Stream On/Off
S: Show/Stop Diagnostics
L: Load New Software
M: Main Menu (this)

->Node Id = 80
->Baudrate= 125 [kbps]
CO: PRE-OPERATIONAL
Activating new baud = 250 [kbps]
CO: STOP
Restarting CAN in 5000 [ms]
CO: PRE-OPERATIONAL
Storing ID
Storing Factory Parameters

Storing Baud
Storing Factory Parameters

Storing Communication Parameters

->Node Id = 80
->Baudrate= 250 [kbps]
CO: PRE-OPERATIONAL
  
```

3.2. COMMUNICATION OBJECTS (DS-301 and DS-404)

The communication objects supported by the 1i2o Controller are listed in the following table. A more detailed description of some of the objects is given in the following subchapters. Only those objects that have device-profile specific information are described. For more information on the other objects, refer to the generic CANopen protocol specification DS-301.

Index (hex)	Object	Object Type	Data Type	Access	PDO Mapping
1000	Device Type	VAR	UNSIGNED32	RO	No
1001	Error Register	VAR	UNSIGNED8	RO	No
1002	Manufacturer Status Register	VAR	UNSIGNED32	RO	No
1003	Pre-Defined Error Field	ARRAY	UNSIGNED32	RO	No
100C	Guard Time	VAR	UNSIGNED16	RW	No
100D	Life Time Factor	VAR	UNSIGNED8	RW	No
1010	Store Parameters	ARRAY	UNSIGNED32	RW	No
1011	Restore Default Parameters	ARRAY	UNSIGNED32	RW	No
1016	Consumer Heartbeat Time	ARRAY	UNSIGNED32	RW	No
1017	Producer Heartbeat Time	VAR	UNSIGNED16	RW	No
1018	Identity Object	RECORD		RO	No
1020	Verify Configuration	ARRAY	UNSIGNED32	RW	No
1029	Error Behaviour	ARRAY	UNSIGNED8	RW	No
1400	RPDO1 Communication Parameter	RECORD		RW	No
1401	RPDO2 Communication Parameter	RECORD		RW	No
1402	RPDO3 Communication Parameter	RECORD		RW	No
1403	RPDO4 Communication Parameter	RECORD		RW	No
1600	RPDO1 Mapping Parameter	RECORD		RO	No
1601	RPDO2 Mapping Parameter	RECORD		RO	No
1602	RPDO3 Mapping Parameter	RECORD		RO	No
1603	RPDO4 Mapping Parameter	RECORD		RO	No
1800	TPDO1 Communication Parameter	RECORD		RW	No
1801	TPDO2 Communication Parameter	RECORD		RW	No
1802	TPDO3 Communication Parameter	RECORD		RW	No
1803	TPDO4 Communication Parameter	RECORD		RW	No
1A00	TPDO1 Mapping Parameter	RECORD		RW	No
1A01	TPDO2 Mapping Parameter	RECORD		RW	No
1A02	TPDO3 Mapping Parameter	RECORD		RW	No
1A03	TPDO4 Mapping Parameter	RECORD		RW	No

3.2.1. Object 1000h: Device Type

This object contains information about the device type as per device profile DS-404. The 32-bit parameter is divided into two 16-bit values, showing General and Additional information as shown below.

MSB	LSB
Additional Information = 0x201F	General Information = 0x0194 (404)

DS-404 defines the Additional Information field in the following manner:

- 0000h = reserved
- 0001h = digital input block
- 0002h = analog input block
- 0004h = digital output block
- 0008h = analog output block
- 0010h = controller block (aka PID)
- 0020h = alarm block
- 0040h ... 0800h = reserved
- 1000h = reserved
- 2000h = lookup table block (manufacturer-specific)
- 4000h = programmable logic block (manufacturer-specific)
- 8000h = miscellaneous block (manufacturer-specific)

Object Description

Index	1000h
Name	Device Type
Object Type	VAR
Data Type	UNSIGNED32

Entry Description

Access	RO
PDO Mapping	No
Value Range	0xE01F0194
Default Value	0xE01F0194

3.2.2. Object 1001h: Error Register

This object is an error register for the device. Any time there is an error detected by the 1i2o Controller, the Generic Error Bit (bit 0) is set. Only if there is no errors in the module will this bit will be cleared. No other bits in this register are used by the 1i2o Controller.

Object Description

Index	1001h
Name	Error Register
Object Type	VAR
Data Type	UNSIGNED8

Entry Description

Access	RO
PDO Mapping	No
Value Range	00h or 01h
Default Value	0

3.2.3. Object 1002h: Manufacturer Status Register

This object is used for manufacturer debug purposes.

3.2.4. Object 1003h: Pre-Defined Error Field

This object provides an error history by listing the errors in the order that they have occurred. An error is added to the top of the list when it occurs, and is immediately removed when the error condition has been cleared. The latest error is always at sub-index 1, with sub-index 0 containing the number of errors currently in the list. When the device is in an error-free state, the value of sub-index 0 is zero.

The error list may be cleared by writing a zero to sub-index 0, which will clear all errors from the list, regardless of whether or not they are still present. Clearing the list does NOT mean that the module will return to the error-free behaviour state if at least one error is still active.

The 1i2o Controller has a limitation of a maximum of 4 errors in the list. If the device registers more errors, the list will be truncated, and the oldest entries will be lost.

The error codes stored in the list are 32-bit unsigned numbers, consisting of two 16-bit fields. The lower 16-bit field is the EMCY error code, and the higher 16-bit field is a manufacturer-specific code. The manufacturer-specific code is divided into two 8-bit fields, with the higher byte indicating the error description, and the lower byte indicating the channel on which the error occurred.

MSB

LSB

Error Description	Channel-ID	EMCY Error Code
-------------------	------------	-----------------

If node-guarding is used (not recommended per the latest standard) and a lifeguard event occurs, the manufacturer-specific field will be set to 0x1000. On the other hand, if a heartbeat consumer fails to be received within the expected timeframe, the Error Description will be set to 0x80 and the Channel-ID (nn) will reflect the Node-ID of the consumer channel that was not producing. In this case, the manufacturer-specific field will therefore be 0x80nn. In both cases, the corresponding EMCY Error Code will be the Guard Error 0x8130.

When an analog input fault is detected as described in Section 1.3 or an analog output is not working as described in Section 1.5, then the Error Description will reflect what channel(s) is at fault using the following table. Also, if an RPDO is not received within the expected “Event Timer” period, an RPDO timeout will be flagged. Table 32 outlines the resulting Error Field Codes and their meanings.

Error Field Code	Error Description	Meaning	ID	Meaning	EMCY Code	Meaning
00000000h	EMCY Error Reset (fault no longer active)					
2001F001h	20h	Positive Overload (Out of Range High)	01h	Analog Input 1	F001h	Input Overload
4001F001h	40h	Negative Overload (Out of Range Low)	01h	Analog Input 1	F001h	Input Overload
1001F002h	10h	Sensor Break (Open Circuit on AO)	01h	Analog Output 1	F002h	Output Overload
1002F002h	10h	Sensor Break (Open Circuit on AO)	02h	Analog Output 2	F002h	Output Overload
00012310h	00h	Short Circuit on AO	01h	Analog Output 1	2310h	Current at Output too High (short to GND or +Vcc)
00022310h	00h	Short Circuit on AO	02h	Analog Output 2	2310h	Current at Output too High (short to GND or +Vcc)
00008100h	00h	RPDO Timeout	00h	Unspecified	8100h	Communication - generic
10008130h	10h	Lifeguard Event	00h	Unspecified	8130h	Lifeguard/Heartbeat Error
80nn8130h	80h	Heartbeat Timeout	nn	Node-ID	8130h	Lifeguard/Heartbeat Error

Table 33 – Pre-Defined Error Field Codes

Object Description

Index	1003h
Name	Pre-Defined Error Field
Object Type	ARRAY
Data Type	UNSIGNED32

Entry Description

Sub-Index	0h
Description	Number of entries
Access	RW
PDO Mapping	No
Value Range	0 to 4
Default Value	0

Sub-Index	1h to 4
Description	Standard error field
Access	RO
PDO Mapping	No
Value Range	UNSIGNED32
Default Value	0

3.2.5. Object 100Ch: Guard Time

The objects at index 100Ch and 100Dh shall indicate the configured guard time respective to the life time factor. The life time factor multiplied with the guard time gives the life time for the life guarding protocol described in DS-301. The Guard Time value shall be given in multiples of ms, and a value of 0000h shall disable the life guarding.

It should be noted that this object, and that of 100Dh are only supported for backwards compatibility. The standard recommends that newer networks do not use the life guarding protocol, but rather heartbeat monitoring instead. Both life guarding and heartbeats can NOT be active simultaneously.

Object Description

Index	100Ch
Name	Guard Time
Object Type	VAR
Data Type	UNSIGNED16

Entry Description

Sub-Index	0h
Access	RW
PDO Mapping	No
Value Range	0 to 65535
Default Value	0

3.2.6. Object 100Dh: Lifetime Factor

The life time factor multiplied with the guard time gives the life time for the life guarding protocol. A value of 00h shall disable life guarding.

Object Description

Index	100Dh
Name	Life time factor
Object Type	VAR
Data Type	UNSIGNED8

Entry Description

Sub-Index	0h
Access	RW
PDO Mapping	No
Value Range	0 to 255
Default Value	0

3.2.7. Object 1010h: Store Parameters

This object supports the saving of parameters in non-volatile memory. In order to avoid storage of parameters by mistake, storage is only executed when a specific signature is written to the appropriate sub-index. The signature is “save”.

The signature is a 32-bit unsigned number, composed of the ASCII codes of the signature characters, according to the following table:

MSB		LSB	
e	v	a	s
65h	76h	61h	73h

On reception of the correct signature to an appropriate sub-index, the 1i2o Controller will store the parameters in non-volatile memory, and then confirm the SDO transmission.

By read access, the object provides information about the module’s saving capabilities. For all sub-indexes, this value is 1h, indicating that the 1i2o Controller saves parameters on command. **This means that if power is removed before the Store object is written, changes to the Object Dictionary will NOT have been saved in the non-volatile memory, and will be lost on the next power cycle.**

Object Description

Index	1010h
Name	Store Parameters
Object Type	ARRAY
Data Type	UNSIGNED32

Entry Description

Sub-Index	0h
Description	Largest sub-index supported
Access	RO
PDO Mapping	No
Value Range	4
Default Value	4

Sub-Index	1h
Description	Save all parameters
Access	RW
PDO Mapping	No
Value Range	0x65766173 (write access) 1h (read access)
Default Value	1h

Sub-Index	2h
Description	Save communication parameters
Access	RW
PDO Mapping	No
Value Range	0x65766173 (write access) 1h (read access)
Default Value	1h

Sub-Index	3h
Description	Save application parameters
Access	RW
PDO Mapping	No
Value Range	0x65766173 (write access) 1h (read access)
Default Value	1h

Sub-Index	4h
Description	Save manufacturer parameters
Access	RW
PDO Mapping	No
Value Range	0x65766173 (write access) 1h (read access)
Default Value	1h

3.2.8. Object 1011h: Restore Parameters

This object supports the restoring of the default values for the object dictionary in non-volatile memory. In order to avoid restoring of parameters by mistake, the device restores the defaults only when a specific signature is written to the appropriate sub-index. The signature is “load”.

The signature is a 32-bit unsigned number, composed of the ASCII codes of the signature characters, according to the following table:

MSB		LSB	
d	a	o	l
64h	61h	6Fh	6Ch

On reception of the correct signature to an appropriate sub-index, the 1i2o Controller will restore the defaults in non-volatile memory, and then confirm the SDO transmission. **The default values are set valid only after the device is reset or power-cycled.** This means that the 1i2o Controller will NOT start using the default values right away, but rather continue to run from whatever values were in the Object Dictionary prior to the restore operation.

By read access, the object provides information about the module’s default parameter restoring capabilities. For all sub-indexes, this value is 1h, indicating that the 1i2o Controller restores defaults on command.

Object Description

Index	1011h
Name	Restore Default Parameters
Object Type	ARRAY
Data Type	UNSIGNED32

Entry Description

Sub-Index	0h
Description	Largest sub-index supported
Access	RO
PDO Mapping	No
Value Range	4
Default Value	4

Sub-Index	1h
Description	Restore all default parameters
Access	RW
PDO Mapping	No
Value Range	0x64616F6C (write access), 1h (read access)
Default Value	1h

Sub-Index	2h
Description	Restore default communication parameters
Access	RW
PDO Mapping	No
Value Range	0x64616F6C (write access), 1h (read access)
Default Value	1h

Sub-Index	3h
Description	Restore default application parameters
Access	RW
PDO Mapping	No
Value Range	0x64616F6C (write access), 1h (read access)
Default Value	1h

Sub-Index	4h
Description	Restore default manufacturer parameters
Access	RW
PDO Mapping	No
Value Range	0x64616F6C (write access), 1h (read access)
Default Value	1h

3.2.9. Object 1016h: Consumer Heartbeat Time

The 1i2o Controller can be a consumer of heartbeat objects for up to four modules. This object defines the expected heartbeat cycle time for those modules, and if set to zero, it is not used. When non-zero, the time is a multiple of 1ms, and monitoring will start after the reception of the first heartbeat from the module. If the 1i2o Controller fails to receive a heartbeat from a node in the expected timeframe, it will indicate a communication error, and respond as per object 1029h.

Bits	31-24	23-16	15-0
Value	Reserved 00h	Node-ID	Heartbeat time
Encoded as		UNSIGNED8	UNSIGNED16

Object Description

Index	1016h
Name	Consumer heartbeat time
Object Type	ARRAY
Data Type	UNSIGNED32

Entry Description

Sub-Index	0h
Description	Number of entries
Access	RO
PDO Mapping	No
Value Range	4
Default Value	4

Sub-Index	1h to 4h
Description	Consumer heartbeat time
Access	RW
PDO Mapping	No
Value Range	UNSIGNED32
Default Value	0

3.2.10. Object 1017h: Producer Heartbeat Time

The 1i2o Controller could be configured to produce a cyclical heartbeat by writing a non-zero value to this object. The value will be given in multiples of 1ms, and a value of 0 shall disable the heartbeat.

Object Description

Index	1017h
Name	Producer heartbeat time
Object Type	VAR
Data Type	UNSIGNED16

Entry Description

Sub-Index	0h
Access	RW
PDO Mapping	No
Value Range	10 to 65535
Default Value	0

3.2.11. Object 1018h: Identity Object

The identity object indicates the data of the 1i2o Controller, including vendor id, device id, software and hardware version numbers, and the serial number.

In the Revision Number entry at sub-index 3, the format of the data is as shown below

MSB	LSB
Major revision number (object dictionary)	Hardware Revision Software Version

Object Description

Index	1018h
Name	Identity Object
Object Type	RECORD
Data Type	Identity Record

Entry Description

Sub-Index	0h
Description	Number of entries
Access	RO
PDO Mapping	No
Value Range	4
Default Value	4

Sub-Index	1h
Description	Vendor ID
Access	RO
PDO Mapping	No
Value Range	0x00000055
Default Value	0x00000055 (Axiomatic)

Sub-Index	2h
Description	Product Code
Access	RO
PDO Mapping	No
Value Range	0xAA022001
Default Value	0xAA022001

Sub-Index	3h
Description	Revision Number
Access	RO
PDO Mapping	No
Value Range	UNSIGNED32
Default Value	0x00010201

Sub-Index	4h
Description	Serial Number
Access	RO
PDO Mapping	No
Value Range	UNSIGNED32
Default Value	No

3.2.12. Object 1020h: Verify Configuration

This object can be read to see what date the software (version identified in object 1018h) was compiled. The date is represented as a hexadecimal value showing day/month/year as per the format below. The time value at sub-index 2 is a hexadecimal value showing the time in a 24 hour clock

MSB		LSB
Day (in 1-Byte Hex)	Month (in 1-Byte Hex)	Year (in 2-Byte Hex)
00	00	Time (in 2-Byte Hex)

For example, a value of 0x10082010 would indicate that the software was compiled on August 10th, 2010. A time value of 0x00001620 would indicate it was compiled at 4:20pm.

Object Description

Index	1020h
Name	Verify configuration
Object Type	ARRAY
Data Type	UNSIGNED32

Entry Description

Sub-Index	0h
Description	Number of entries
Access	RO
PDO Mapping	No
Value Range	2
Default Value	2

Sub-Index	1h
Description	Configuration date
Access	RO
PDO Mapping	No
Value Range	UNSIGNED32
Default Value	No

Sub-Index	2h
Description	Configuration time
Access	RO
PDO Mapping	No
Value Range	UNSIGNED32
Default Value	No

3.2.13. Object 1029h: Error Behaviour

This object controls the state that the 1i2o Controller will be set into in case of an error of the type associated with the sub-index.

A network fault is flagged when an RPDO is not received within the expected time period defined in the “Event Timer” of the associated communication objects, (see Section 3.2.14 for more information) or if a lifeguard or heartbeat message is not received as expected. Input faults are defined in Section 1.3, and output faults are defined in Section 1.5.

For all sub-indexes, the following definitions hold true:

- 0 = Pre-Operational (node reverts to a pre-operational state when this fault is detected)
- 1 = No State Change (node remains in the same state it was in when the fault occurred)
- 2 = Stopped (node goes into stopped mode when the fault occurs)

Object Description

Index	1029h
Name	Error Behaviour
Object Type	ARRAY
Data Type	UNSIGNED8

Entry Description

Sub-Index	0h
Description	Number of entries
Access	RO
PDO Mapping	No
Value Range	5
Default Value	5

Sub-Index	1h
Description	Communication Fault
Access	RW
PDO Mapping	No
Value Range	See above
Default Value	1 (No State Change)

Sub-Index	2h
Description	Digital Input Fault (not used)
Access	RW
PDO Mapping	No
Value Range	See above
Default Value	1 (No State Change)

Sub-Index	3h
Description	Analog Input Fault (AI1)
Access	RW
PDO Mapping	No
Value Range	See above
Default Value	1 (No State Change)

Sub-Index	4h
Description	Digital Output Fault (not used)
Access	RW
PDO Mapping	No
Value Range	See above
Default Value	1 (No State Change)

Sub-Index	5h
Description	Analog Output Fault (AO1 to AO4)
Access	RW
PDO Mapping	No
Value Range	See above
Default Value	1 (No State Change)

3.2.14. RPDO Behaviour

Per the CANopen ® standard DS-301, the following procedure shall be used for re-mapping, and is the same for both RPDOs and TPDOs.

- a) Destroy the PDO by setting bit **exists** (most significant bit) of sub-index 01h of the according PDO communication parameter to 1b
- b) Disable mapping by setting sub-index 00h of the corresponding mapping object to 0
- c) Modify the mapping by changing the values of the corresponding sub-indices
- d) Enable mapping by setting sub-index 00h to the number of mapped objects
- e) Create the PDO by setting bit **exists** (most significant bit) of sub-index 01h of the according PDO communication parameter to 0b

The 1i2o Controller can support up to four RPDO messages. All RPDOs on the 1i2o Controller use the similar default communication parameters, with the PDO IDs set according to the pre-defined connection set described in DS-301. Most RPDOs do not exist, there is no RTR allowed, they use 11-bit CAN-IDs (base frame valid) and they are all event-driven. While all four have valid default mappings defined (see below) only RPDO1 is enabled by default (i.e. RPDO exists).

RPDO1 Mapping at Object 1600h: Default ID 0x200 + Node ID

Sub-Index	Value	Object
0	2	Number of mapped application objects in PDO
1	0x73000110	Analog Output 1 Process Value
2	0x73000210	Analog Output 2 Process Value
3	0	Not used by default
4	0	Not used by default

RTPDO2 Mapping at Object 1601h: Default ID 0x300 + Node ID

Sub-Index	Value	Object
0	2	Number of mapped application objects in PDO
1	0x25000110	Extra Received 1 PV (i.e. PID Control Feedback 1 PV)
2	0x25000210	Extra Received 2 PV (i.e. PID Control Feedback 2 PV)
3	0	Not used by default
4	0	Not used by default

RPDO3 Mapping at Object 1602h: Default ID 0x400 + Node ID

Sub-Index	Value	Object
0	4	Number of mapped application objects in PDO
1	0x25000310	Extra Received 3 PV (i.e. Lookup Table 1 X-Axis)
2	0x25000410	Extra Received 4 PV (i.e. Lookup Table 2 X-Axis)
3	0x25000510	Extra Received 5 PV (i.e. Lookup Table 3 X-Axis)
4	0x25000610	Extra Received 6 PV (i.e. Lookup Table 4 X-Axis)

RPDO4 Mapping at Object 1603h: Default ID 0x500 + Node ID

Sub-Index	Value	Object
0	2	Number of mapped application objects in PDO
1	0x62200108	Digital Output 1 Write State 1 Output Line
2	0x62200208	Digital Output 2 Write State 1 Output Line
3	0	Not used by default
4	0	Not used by default

None of them have the timeout feature enabled, i.e. the “Event Timer” on sub-index 5 is set to zero. When this is changed to a non-zero value, if the RPDO has not been received from another node within the time period defined (while in Operational mode), a network fault is activated, and the controller will go to the operational state define in Object 1029h sub-index 4.

Object Description

Index	1400h to 1403h
Name	RPDO communication parameter
Object Type	RECORD
Data Type	PDO Communication Record

Entry Description

Sub-Index	0h
Description	Number of entries
Access	RO
PDO Mapping	No
Value Range	5
Default Value	5

Sub-Index	1h
Description	COB-ID used by RPDO
Access	RW
PDO Mapping	No
Value Range	See value definition in DS-301
Default Value	40000000h + RPDO1 + Node ID C0000000h + RPDOx + Node-ID

X	RPDOx ID
1	0200h
2	0300h
3	0400h
4	0500h

Node-ID = Node-ID of the module. The RPDO COB-IDs are automatically updated if the Node-ID is changed by LSS protocol.

80000000h in the COB-ID indicates that the PDO does not exist (destroyed)

04000000h in the COB-ID indicates that there is no RTR allowed on the PDO

Sub-Index	2h
Description	Transmission type
Access	RO
PDO Mapping	No
Value Range	See value definition in DS-301
Default Value	255 (FFh) = Event Driven

Sub-Index	3h
Description	Inhibit Time
Access	RW
PDO Mapping	No
Value Range	See value definition in DS-301
Default Value	0

Sub-Index	4h
Description	Compatibility entry
Access	RW
PDO Mapping	No
Value Range	UNSIGNED8
Default Value	0

Sub-Index	5
Description	Event-timer
Access	RW
PDO Mapping	No
Value Range	See value definition in DS-301
Default Value	0

Recall: A non-zero event timer for an RPDO means that it will result in a network fault being flagged if it has not been received within this timeframe while in Operational mode.

3.2.15. TPDO Behaviour

The 1i2o Controller can support up to four TPDO messages. All TPDOs on the 1i2o Controller use the similar default communication parameters, with the PDO IDs set according to the pre-defined connection set described in DS-301. Most TPDOs do not exist, there is no RTR allowed, they use 11-bit CAN-IDs (base frame valid) and they are all time-driven. While all four have valid default mappings defined (see below) only TPDO1 is enabled by default (i.e. TPDO exists).

TPDO1 Mapping at Object 1A00h: Default ID 0x180 + Node ID

Sub-Index	Value	Object
0	3	Number of mapped application objects in PDO
1	0x71000110	Analog Input 1 Field Value
2	0x23700110	Analog Output 1 Feedback Field Value
3	0x23700210	Analog Output 2 Feedback Field Value
4	0	Not used by default

TPDO2 Mapping at Object 1A01h: Default ID 0x280 + Node ID

Sub-Index	Value	Object
0	2	Number of mapped application objects in PDO
1	0x73300110	Analog Output 1 Field Value
2	0x73300210	Analog Output 2 Field Value
3	0	Not used by default
4	0	Not used by default

TPDO3 Mapping at Object 1A02h: Default ID 0x380 + Node ID

Sub-Index	Value	Object
0	2	Number of mapped application objects in PDO
1	0x24600110	PID Control Output 1 Field Value
2	0x24600210	PID Control Output 2 Field Value
3	0	Not used by default
4	0	Not used by default

TPDO4 Mapping at Object 1A03h: Default ID 0x480 + Node ID

Sub-Index	Value	Object
0	2	Number of mapped application objects in PDO
1	0x50200020	Power Supply Field Value (measured)
2	0x50300020	Processor Temperature Field Value (measured)
3	0	Not used by default
4	0	Not used by default

Since all but TPDO1 has a zero value transmission rate (i.e. Event Timer in sub-index 5 of communication object), only TPDO1 will be automatically broadcasted when the unit goes into OPERATIONAL mode.

Object Description

Index	1800h to 1803h
Name	TPDO communication parameter
Object Type	RECORD
Data Type	PDO Communication Record

Entry Description

Sub-Index	0h
Description	Number of entries
Access	RO
PDO Mapping	No
Value Range	5
Default Value	5

Sub-Index	1h
Description	COB-ID used by TPDO
Access	RW
PDO Mapping	No
Value Range	See value definition in DS-301
Default Value	40000000h + TPDO1 + Node-ID C0000000h + TPDOx + Node-ID

X	TPDOx ID
1	0180h
2	0280h
3	0380h
4	0480h

Node-ID = Node-ID of the module. The TPDO COB-IDs are automatically updated if the Node-ID is changed by LSS protocol.

80000000h in the COB-ID indicates that the PDO does not exist (destroyed)

04000000h in the COB-ID indicates that there is no RTR allowed on the PDO

Sub-Index	2h
Description	Transmission type
Access	RO
PDO Mapping	No
Value Range	See value definition in DS-301
Default Value	254 (FEh) = Event Driven

Sub-Index	3h
Description	Inhibit Time
Access	RW
PDO Mapping	No
Value Range	See value definition in DS-301
Default Value	0

Sub-Index	4h
Description	Compatibility entry
Access	RW
PDO Mapping	No
Value Range	UNSIGNED8
Default Value	0

Sub-Index	5
Description	Event-timer
Access	RW
PDO Mapping	No
Value Range	See value definition in DS-301
Default Value	100ms (on TPDO1) 0ms (on TPDO2, TPDO3, TPDO4)

3.3. APPLICATION OBJECTS (DS-404)

Index (hex)	Object	Object Type	Data Type	Access	PDO Mapping
6020	DI Read State 1 Input Line	ARRAY	BOOLEAN	RO	Yes
6030	DI Polarity 1 Input Line	ARRAY	UNSIGNED8	RW	No
7100	AI Input Field Value	ARRAY	INTEGER16	RO	Yes
6110	AI Sensor Type	ARRAY	UNSIGNED16	RW	No
6112	AI Operating Mode	ARRAY	UNSIGNED8	RW	No
7120	AI Input Scaling 1 FV	ARRAY	INTEGER16	RW	No
7121	AI Input Scaling 1 PV	ARRAY	INTEGER16	RW	No
7122	AI Input Scaling 2 FV	ARRAY	INTEGER16	RW	No
7123	AI Input Scaling 2 PV	ARRAY	INTEGER16	RW	No
7130	AI Input Process Value	ARRAY	INTEGER16	RO	Yes
6132	AI Decimal Digits PV	ARRAY	UNSIGNED8	RW	No
7148	AI Input Span Start	ARRAY	INTEGER16	RW	No
7149	AI Input Span End	ARRAY	INTEGER16	RW	No
61A0	AI Filter Type	ARRAY	UNSIGNED8	RW	No
61A1	AI Filter Constant	ARRAY	UNSIGNED16	RW	No
6220	DO Write State 1 Output Line	ARRAY	BOOLEAN	RW	Yes
6240	DO Polarity 1 Output Line	ARRAY	UNSIGNED8	RW	No
6250	DO Fault Mode 1 Output Line	ARRAY	UNSIGNED8	RW	No
6260	DO Fault State 1 Output Line	ARRAY	BOOLEAN	RW	No
7300	AO Output Process Value	ARRAY	INTEGER16	RW	Yes
6302	AO Decimal Digits PV	ARRAY	UNSIGNED8	RW	No
6310	AO Output Type	ARRAY	UNSIGNED16	RW	No
7320	AO Output Scaling 1 PV	ARRAY	INTEGER16	RW	No
7321	AO Output Scaling 1 FV	ARRAY	INTEGER16	RW	No
7322	AO Output Scaling 2 PV	ARRAY	INTEGER16	RW	No
7323	AO Output Scaling 2 FV	ARRAY	INTEGER16	RW	No
7330	AO Output Field Value	ARRAY	INTEGER16	RO	Yes
6332	AO Decimal Digits FV	ARRAY	UNSIGNED8	RW	No
6340	AO Fault Mode	ARRAY	UNSIGNED8	RW	No
7341	AO Fault Field Value	ARRAY	INTEGER16	RW	No
7450	PID Proportional Band	ARRAY	INTEGER16	RW	No
7452	PID Integral Action Time	ARRAY	INTEGER16	RW	No
7454	PID Derivative Action Time	ARRAY	INTEGER16	RW	No
7456	PID Cycle Time	ARRAY	INTEGER16	RW	No
7458	PID Physical Unit Timing	ARRAY	UNSIGNED32	RO	No
7459	PID Decimal Digits Timing	ARRAY	UNSIGNED8	RW	No

3.3.1. Object 6020h: DI Read State 1 Input Line

This read-only object represents the digital input state from a single input line. Refer to Section 1.2 for more information

Object Description

Index	6020h
Name	DI Read State 1 Input Line
Object Type	ARRAY
Data Type	BOOLEAN

Entry Description

Sub-Index	0h
Description	Largest sub-index supported
Access	RO
PDO Mapping	No
Value Range	1
Default Value	1

Sub-Index	1h
Description	Digital Input 1 State
Access	RO
PDO Mapping	Yes
Value Range	0 (OFF) or 1 (ON)
Default Value	0

3.3.2. Object 6030h: DI Polarity 1 Input Line

This object determines how the state read on the input pin corresponds to the logic state, in conjunction with manufacturer object 2020h, as defined in Table 3.

Object Description

Index	6030h
Name	DI Polarity 1 Input Line
Object Type	ARRAY
Data Type	UNSIGNED8

Entry Description

Sub-Index	0h
Description	Largest sub-index supported
Access	RO
PDO Mapping	No
Value Range	1
Default Value	1

Sub-Index	1h
Description	Digital Input 1 Polarity
Access	RW
PDO Mapping	No
Value Range	See Table 3
Default Value	0 (Normal On/Off)

3.3.3. Object 7100h: AI Input Field Value

This object represents the measured value of an analog input that has been scaled as per manufacturer object 2102h AI Decimal Digits PV. The base unit for each type of input is defined in Table 9, as well as the read-only resolution (decimal digits) associated with the FV.

Object Description

Index	7100h
Name	AI Input Field Value
Object Type	ARRAY
Data Type	INTEGER16

Entry Description

Sub-Index	0h
Description	Largest sub-index supported
Access	RO
PDO Mapping	No
Value Range	1
Default Value	1

Sub-Index	1h
Description	AI1 FV
Access	RO
PDO Mapping	Yes
Value Range	Data Type Specific, see Table 11
Default Value	No

3.3.4. Object 6110h: AI Sensor Type

This object defines the type of sensor (input) which is connected to the analog input pin.

Object Description

Index	6110h
Name	AI Sensor Type
Object Type	ARRAY
Data Type	UNSIGNED16

Entry Description

Sub-Index	0h
Description	Largest sub-index supported
Access	RO
PDO Mapping	No
Value Range	1
Default Value	1

Sub-Index	1h
Description	AI1 Sensor Type
Access	RW
PDO Mapping	No
Value Range	See Table 5
Default Value	40 (voltage)

3.3.5. Object 6112h: AI Operating Mode

This object enables special operating modes for the input.

Object Description

Index	6112h
Name	AI Operating Mode
Object Type	ARRAY
Data Type	UNSIGNED8

Entry Description

Sub-Index	0h
Description	Largest sub-index supported
Access	RO
PDO Mapping	No
Value Range	1
Default Value	1

Sub-Index	1h
Description	AI1 Operating Mode
Access	RW
PDO Mapping	No
Value Range	See Table 4
Default Value	1 (normal operation)

3.3.6. Object 7120h: AI Input Scaling 1 FV

This object describes the field value of the first calibration point for the analog input channel, as shown in Figure 7. It also defines the “minimum” value of the analog input range when using this input as a control source for another function block, as described in Table 17 in Section 1.5. It is scaled in the physical unit of the FV, i.e. object 2102h applies to this object.

Object Description

Index	7120h
Name	AI Input Scaling 1 FV
Object Type	ARRAY
Data Type	INTEGER16

Entry Description

Sub-Index	0h
Description	Largest sub-index supported
Access	RO
PDO Mapping	No
Value Range	1
Default Value	1

Sub-Index	1h
Description	AI1 Scaling 1 FV
Access	RW
PDO Mapping	No
Value Range	See Table 11
Default Value	500 [mV]

3.3.7. Object 7121h: AI Input Scaling 1 PV

This object defines the process value of the first calibration point for the analog input channel, as shown in Figure 7. It is scaled in the physical unit of the PV, i.e. object 6132h applies to this object.

Object Description

Index	7121h
Name	AI Input Scaling 1 PV
Object Type	ARRAY
Data Type	INTEGER16

Entry Description

Sub-Index	0h
Description	Largest sub-index supported
Access	RO
PDO Mapping	No
Value Range	1
Default Value	1

Sub-Index	1h
Description	AI1 Scaling 1 PV
Access	RW
PDO Mapping	No
Value Range	Integer16
Default Value	500 [same as 7120h]

3.3.8. Object 7122h: AI Input Scaling 2 FV

This object describes the field value of the second calibration point for the analog input channel, as shown in Figure 7. It also defines the “maximum” value of the analog input range when using this input as a control source for another function block, as described in Table 17 in Section 1.5. It is scaled in the physical unit of the FV, i.e. object 2102h applies to this object.

Object Description

Index	7122h
Name	AI Input Scaling 2 FV
Object Type	ARRAY
Data Type	INTEGER16

Entry Description

Sub-Index	0h
Description	Largest sub-index supported
Access	RO
PDO Mapping	No
Value Range	1
Default Value	1

Sub-Index	1h
Description	AI1 Scaling 2 FV
Access	RW
PDO Mapping	No
Value Range	See Table 11
Default Value	4500 [mV]

3.3.9. Object 7123h: AI Input Scaling 2 PV

This object defines the process value of the second calibration point for the analog input channel, as shown in Figure 7. It is scaled in the physical unit of the PV, i.e. object 6132h applies to this object.

Object Description

Index	7123h
Name	AI Input Scaling 2 PV
Object Type	ARRAY
Data Type	INTEGER16

Entry Description

Sub-Index	0h
Description	Largest sub-index supported
Access	RO
PDO Mapping	No
Value Range	1
Default Value	1

Sub-Index	1h
Description	AI1 Scaling 2 PV
Access	RW
PDO Mapping	No
Value Range	Integer16
Default Value	4500 [same as 7122h]

3.3.10. Object 7130h: AI Input Process Value

This object represents the result of the input scaling applied per Figure 7, and gives the measured quantity scaled in the physical unit of the process value (i.e. °C, PSI, RPM, etc) with the resolution defined in object 6132h AI Decimal Digits PV.

Object Description

Index	7130h
Name	AI Input Process Value
Object Type	ARRAY
Data Type	INTEGER16

Entry Description

Sub-Index	0h
Description	Largest sub-index supported
Access	RO
PDO Mapping	No
Value Range	1
Default Value	1

Sub-Index	1h
Description	AI1 Process Value
Access	RO
PDO Mapping	Yes
Value Range	Integer16
Default Value	No

3.3.11. Object 6132h: AI Decimal Digits PV

This object describes the number of digits following the decimal point (i.e. resolution) of the input data, which is interpreted with data type Integer16 in the process value object.

Example: A process value of 1.230 (Float) will be coded as 1230 in Integer16 format if the number of decimal digits is set to 3.

Object Description

Index	6123h
Name	AI Decimal Digits PV
Object Type	ARRAY
Data Type	UNSIGNED8

Entry Description

Sub-Index	0h
Description	Largest sub-index supported
Access	RO
PDO Mapping	No
Value Range	1
Default Value	1

Sub-Index	1h
Description	AI1 Decimal Digits PV
Access	RW
PDO Mapping	No
Value Range	0 to 4
Default Value	3 [Volt to mV]

3.3.12. Object 7148h: AI Span Start

This value specifies the lower limit where field values are expected. Field values which are lower than this limit are marked as negative overload. It is scaled in the physical unit of the FV, i.e. object 2102h applies to this object.

Object Description

Index	7148h
Name	AI Span Start
Object Type	ARRAY
Data Type	INTEGER16

Entry Description

Sub-Index	0h
Description	Largest sub-index supported
Access	RO
PDO Mapping	No
Value Range	1
Default Value	1

Sub-Index	1h
Description	AI1 Span Start (Error Min)
Access	RW
PDO Mapping	No
Value Range	See Table 11
Default Value	200 [mV]

3.3.13. Object 7149h: AI Span End

This value specifies the upper limit where field values are expected. Field values which are higher than this limit are marked as positive overload. It is scaled in the physical unit of the FV, i.e. object 2102h applies to this object.

Object Description

Index	7149h
Name	AI Span End
Object Type	ARRAY
Data Type	INTEGER16

Entry Description

Sub-Index	0h
Description	Largest sub-index supported
Access	RO
PDO Mapping	No
Value Range	1
Default Value	1

Sub-Index	1h
Description	AI1 Span End (Error Max)
Access	RW
PDO Mapping	No
Value Range	See Table 11
Default Value	4800 [mV]

3.3.14. Object 61A0h: AI Filter Type

This object defines the type of data filter that will be applied to the raw input data, as read from the ADC or Timer, before it is passed to the field value object. The types of data filters are defined in Table 8, and how they are used is outlined in Section 1.3.

Object Description

Index	61A0h
Name	AI Filter Type
Object Type	ARRAY
Data Type	UNSIGNED8

Entry Description

Sub-Index	0h
Description	Largest sub-index supported
Access	RO
PDO Mapping	No
Value Range	1
Default Value	1

Sub-Index	1h
Description	AI1 Filter Type
Access	RW
PDO Mapping	No
Value Range	See Table 8
Default Value	0 (no filter)

3.3.15. Object 61A1h: AI Filter Constant

This object defines the number of steps used in the various filters, as defined in Section 1.3

Object Description

Index	61A0h
Name	AI Filter Constant
Object Type	ARRAY
Data Type	UNSIGNED16

Entry Description

Sub-Index	0h
Description	Largest sub-index supported
Access	RO
PDO Mapping	No
Value Range	1
Default Value	1

Sub-Index	1h
Description	AI1 Filter Constant
Access	RW
PDO Mapping	No
Value Range	1 to 1000
Default Value	10

3.3.16. Object 6220h: DO Write State 1 Output Line

This object shall set a single digital output logic state when the corresponding DO is being controlled by a CANopen Message (per Table 15 in Section 1.5).

Object Description

Index	6220h
Name	DO Write State 1 Output Line
Object Type	ARRAY
Data Type	BOOLEAN

Entry Description

Sub-Index	0h
Description	Largest sub-index supported
Access	RO
PDO Mapping	No
Value Range	2
Default Value	2

Sub-Index	1h to 2h (x = 1 or 2)
Description	DOx Write State
Access	RW
PDO Mapping	Yes
Value Range	0 (OFF) or 1 (ON)
Default Value	0 (OFF)

3.3.17. Object 6240h: DO Polarity 1 Output Line

This object defines the relationship between the logic state and the drive state of a single digital output, as described in Table 12.

Object Description

Index	6240h
Name	DO Polarity 1 Output Line
Object Type	ARRAY
Data Type	UNSIGNED8

Entry Description

Sub-Index	0h
Description	Largest sub-index supported
Access	RO
PDO Mapping	No
Value Range	2
Default Value	2

Sub-Index	1h to 2h (x = 1 or 2)
Description	DOx Polarity
Access	RW
PDO Mapping	No
Value Range	See Table 12
Default Value	0 (normal on/off)

3.3.18. Object 6250h: DO Fault Mode 1 Output Line

This object defines how a single digital output shall response when a fault condition is detected on any control input, as described in Table 13.

Object Description

Index	6250h
Name	DO Fault Mode 1 Output Line
Object Type	ARRAY
Data Type	UNSIGNED8

Entry Description

Sub-Index	0h
Description	Largest sub-index supported
Access	RO
PDO Mapping	No
Value Range	2
Default Value	2

Sub-Index	1h to 2h (x = 1 or 2)
Description	DOx Fault Mode
Access	RW
PDO Mapping	No
Value Range	See Table 13
Default Value	1 (apply pre-defined state)

3.3.19. Object 6260h: DO Fault State 1 Output Line

This object defines the pre-defined state of a single digital output when a fault condition is present, and the corresponding sub-index in object 6250h is enabled.

Object Description

Index	6260h
Name	DO Fault State 1 Output Line
Object Type	ARRAY
Data Type	BOOLEAN

Entry Description

Sub-Index	0h
Description	Largest sub-index supported
Access	RO
PDO Mapping	No
Value Range	2
Default Value	2

Sub-Index	1h to 2h (x = 1 or 2)
Description	DOx Fault State
Access	RW
PDO Mapping	No
Value Range	0 (OFF) or 1 (ON)
Default Value	1 (ON)

3.3.20. Object 7300h: AO Output Process Value

This object represents the process value of the output. It can be used as an input to the analog output function block when the input has been selected as controlled by a CANopen Message (per Table 15 in Section 1.5).

Object Description

Index	7300h
Name	Analog Output Process Value
Object Type	ARRAY
Data Type	INTEGER16

Entry Description

Sub-Index	0h
Description	Largest sub-index supported
Access	RO
PDO Mapping	No
Value Range	2
Default Value	2

Sub-Index	1h to 2h (x = 1 or 2)
Description	AOx Process Value
Access	RW
PDO Mapping	Yes
Value Range	Integer16
Default Value	No

3.3.21. Object 6302h: AO Decimal Digits PV

This object describes the number of digits following the decimal point (i.e. resolution) of the output control data, which is interpreted with data type Integer16 in the process value object.

Object Description

Index	6302h
Name	AO Decimal Digits PV
Object Type	ARRAY
Data Type	UNSIGNED8

Entry Description

Sub-Index	0h
Description	Largest sub-index supported
Access	RO
PDO Mapping	No
Value Range	2
Default Value	2

Sub-Index	1h to 2h (x = 1 or 2)
Description	AOx Decimal Digits PV
Access	RW
PDO Mapping	No
Value Range	0 to 4
Default Value	3 [same as analog input: Volt to mV]

3.3.22. Object 6310h: AO Output Type

This object specifies the type of analog output, as defined in Table 14.

Object Description

Index	6310h
Name	AO Output Type
Object Type	ARRAY
Data Type	UNSIGNED16

Entry Description

Sub-Index	0h
Description	Largest sub-index supported
Access	RO
PDO Mapping	No
Value Range	2
Default Value	2

Sub-Index	1h to 2h (x = 1 or 2)
Description	AOx Type
Access	RW
PDO Mapping	No
Value Range	See Table 14
Default Value	20 (current)

3.3.23. Object 7320h: AO Output Scaling 1 PV

This object defines the minimum value of the input, and should be specified to equal the corresponding scaling object of the control source, as outlined in Table 17. It will be scaled in the physical unit of the control source. The resolution will ALWAYS be dependent on object 6302h AO Decimal Digits PV, even when the output is not being controlled directly by the AO Output PV object 7300h. This object must always be smaller than object 7322h AO Output Scaling 2 PV.

Object Description

Index	7320h
Name	AO Output Scaling 1 PV
Object Type	ARRAY
Data Type	INTEGER16

Entry Description

Sub-Index	0h
Description	Largest sub-index supported
Access	RO
PDO Mapping	No
Value Range	2
Default Value	2

Sub-Index	1h
Description	AO1 Scaling 1 PV
Access	RW
PDO Mapping	No
Value Range	See Table 17
Default Value	2650 [mV]

Sub-Index	2h
Description	AO2 Scaling 1 PV
Access	RW
PDO Mapping	No
Value Range	See Table 17
Default Value	500 [mV]

3.3.24. Object 7321h: AO Output Scaling 1 FV

This object defines the output field value when the input data is at or below the AO Output Scaling 1 PV value as shown in Figure 11. It will be scaled in the physical unit of the output, dependent on type, with the resolution defined in object 6332h AO Decimal Digits FV. The value can be set anywhere within the allowable output range as outlined in Table 14. This value can be set higher than object 7323h AO Output Scaling 2 FV for an inverse response (i.e. decreasing) to an increasing input.

Object Description

Index	7321h
Name	AO Output Scaling 1 FV
Object Type	ARRAY
Data Type	INTEGER16

Entry Description

Sub-Index	0h
Description	Largest sub-index supported
Access	RO
PDO Mapping	No
Value Range	2
Default Value	2

Sub-Index	1h
Description	AO1 Scaling 1 FV
Access	RW
PDO Mapping	No
Value Range	Dependent on type (see Table 14)
Default Value	300 [mA]

Sub-Index	2h
Description	AO2 Scaling 1 FV
Access	RW
PDO Mapping	No
Value Range	Dependent on type (see Table 14)
Default Value	1500 [mA]

3.3.25. Object 7322h: AO Output Scaling 2 PV

This object defines the maximum value of the input, and should be specified to equal the corresponding scaling object of the control source, as outlined in Table 17. It will be scaled in the physical unit of the control source. The resolution will ALWAYS be dependent on object 6302h AO Decimal Digits PV, even when the output is not being controlled directly by the AO Output PV object 7300h. This object must always be larger than object 7322h AO Output Scaling 2 PV.

Object Description

Index	7322h
Name	AO Output Scaling 2 PV
Object Type	ARRAY
Data Type	INTEGER16

Entry Description

Sub-Index	0h
Description	Largest sub-index supported
Access	RO
PDO Mapping	No
Value Range	2
Default Value	2

Sub-Index	1h
Description	AO1 Scaling 2 PV
Access	RW
PDO Mapping	No
Value Range	See Table 17
Default Value	4500 [mV]

Sub-Index	2h
Description	AO2 Scaling 2 PV
Access	RW
PDO Mapping	No
Value Range	See Table 17
Default Value	2350 [mV]

3.3.26. Object 7323h: AO Output Scaling 2 FV

This object defines the output field value when the input data is at or above the AO Output Scaling 2 PV value as shown in Figure 11. It will be scaled in the physical unit of the output, dependent on type, with the resolution defined in object 6332h AO Decimal Digits FV. The value can be set anywhere within the allowable output range as outlined in Table 14. This value can be set lower than object 7321h AO Output Scaling 1 FV for an inverse response (i.e. decreasing) to an increasing input.

Object Description

Index	7323h
Name	AO Output Scaling 2 FV
Object Type	ARRAY
Data Type	INTEGER16

Entry Description

Sub-Index	0h
Description	Largest sub-index supported
Access	RO
PDO Mapping	No
Value Range	2
Default Value	2

Sub-Index	1h
Description	AO1 Scaling 2 FV
Access	RW
PDO Mapping	No
Value Range	Dependent on type (see Table 14)
Default Value	1500 [mA]

Sub-Index	2h
Description	AO2 Scaling 2 FV
Access	RW
PDO Mapping	No
Value Range	Dependent on type (see Table 14)
Default Value	300 [mA]

3.3.27. Object 7330h: AO Output Field Value

This object represents the target output drive field value as a result of the output logic described in Section 1.5, and the scaling applied as shown in Figure 11. It is defined in the physical unit of the output dependent on type, as outlined in Table 14. The resolution of the object is defined in object 6332h AO Decimal Digits FV.

Object Description

Index	7330h
Name	Analog Output Field Value
Object Type	ARRAY
Data Type	INTEGER16

Entry Description

Sub-Index	0h
Description	Largest sub-index supported
Access	RO
PDO Mapping	No
Value Range	2
Default Value	2

Sub-Index	1h to 2h (x = 1 or 2)
Description	AOx Field Value
Access	RO
PDO Mapping	Yes
Value Range	Integer16
Default Value	No

3.3.28. Object 6332h: AO Decimal Digits FV

This object describes the number of digits following the decimal point (i.e. resolution) of the output data, which is interpreted with data type Integer16 in the field value object.

Object Description

Index	6332h
Name	AO Decimal Digits FV
Object Type	ARRAY
Data Type	UNSIGNED8

Entry Description

Sub-Index	0h
Description	Largest sub-index supported
Access	RO
PDO Mapping	No
Value Range	2
Default Value	2

Sub-Index	1h to 2h (x = 1 or 2)
Description	AOx Decimal Digits FV
Access	RW
PDO Mapping	No
Value Range	0 to 4
Default Value	0 [mA]

3.3.29. Object 6340h: AO Fault Mode

This object defines how an analog output shall response when a fault condition is detected on any control input, as described in Table 22.

Object Description

Index	6340h
Name	AO Fault Mode
Object Type	ARRAY
Data Type	UNSIGNED8

Entry Description

Sub-Index	0h
Description	Largest sub-index supported
Access	RO
PDO Mapping	No
Value Range	2
Default Value	2

Sub-Index	1h to 2h (x = 1 or 2)
Description	AOx Fault Mode
Access	RW
PDO Mapping	No
Value Range	See Table 22
Default Value	1 (apply pre-defined FV)

3.3.30. Object 7341h: AO Fault FV

This object contains the pre-defined field value of an analog output when a fault condition is present, and the corresponding sub-index in object 7341h is enabled. It will be scaled in the physical unit of the output, dependent on type, with the resolution defined in object 6332h AO Decimal Digits FV.

Object Description

Index	7341h
Name	AO Fault FV
Object Type	ARRAY
Data Type	INTEGER16

Entry Description

Sub-Index	0h
Description	Largest sub-index supported
Access	RO
PDO Mapping	No
Value Range	2
Default Value	2

Sub-Index	1h to 2h (x = 1 or 2)
Description	AOx Fault FV
Access	RW
PDO Mapping	No
Value Range	Dependent on type (see Table 14)
Default Value	500 [mA]

3.3.31. Object 7450h: PID Proportional Band

This object describes the proportional band gain (G in Figure 15) of the PID algorithm. The value is always interpreted as having a resolution of one digit after the decimal place.

Object Description

Index	7450h
Name	PID Proportional Band
Object Type	ARRAY
Data Type	INTEGER16

Entry Description

Sub-Index	0h
Description	Largest sub-index supported
Access	RO
PDO Mapping	No
Value Range	2
Default Value	2

Sub-Index	1h to 2h (x = 1 or 2)
Description	PIDx Proportional Gain
Access	RW
PDO Mapping	No
Value Range	0 to 100 (0 to 10.0)
Default Value	50 [0.5]

3.3.32. Object 7452h: PID Integral Action Time

This object describes the integral time (Ti in Figure 15) of the PID algorithm. The physical unit is always seconds, as defined in object 6458h, with the decimal digits (resolution) given in object 6459h. To prevent instability, it is recommended to never set this less than three times higher than object 7454h (Td in Figure 15).

Object Description

Index	7452h
Name	PID Integral Action Time
Object Type	ARRAY
Data Type	INTEGER16

Entry Description

Sub-Index	0h
Description	Largest sub-index supported
Access	RO
PDO Mapping	No
Value Range	2
Default Value	2

Sub-Index	1h to 2h (x = 1 or 2)
Description	PIDx Integral Time
Access	RW
PDO Mapping	No
Value Range	0.001 [sec] to 1 [sec]
Default Value	5 [ms to 0.005sec]

3.3.33. Object 7454h: PID Derivative Action Time

This object describes the derivative time (T_d in Figure 15) of the PID algorithm. The physical unit is always seconds, as defined in object 6458h, with the decimal digits (resolution) given in object 6459h. To prevent instability, it is recommended to never set this more than three times smaller than object 7452h (T_i in Figure 15).

Object Description

Index	7454h
Name	PID Derivative Action Time
Object Type	ARRAY
Data Type	INTEGER16

Entry Description

Sub-Index	0h
Description	Largest sub-index supported
Access	RO
PDO Mapping	No
Value Range	2
Default Value	2

Sub-Index	1h to 2h (x = 1 or 2)
Description	PIDx Derivative Time
Access	RW
PDO Mapping	No
Value Range	0.001 [sec] to 1 [sec]
Default Value	1 [ms to 0.001sec]

3.3.34. Object 7456h: PID Cycle Time

This object defines how frequently the PID loop is called. The physical unit is always seconds, as defined in object 6458h, with the decimal digits (resolution) given in object 6459h.

Object Description

Index	7456h
Name	PID Cycle Time
Object Type	ARRAY
Data Type	INTEGER16

Entry Description

Sub-Index	0h
Description	Largest sub-index supported
Access	RO
PDO Mapping	No
Value Range	2
Default Value	2

Sub-Index	1h to 2h (x = 1 or 2)
Description	PIDx Cycle Time
Access	RW
PDO Mapping	No
Value Range	0.001 [sec] to 1 [sec]
Default Value	10 [ms to 0.010sec]

3.3.35. Object 6458h: PID Physical Unit Timing

This read-only object defines the physical unit of objects 7452h, 7454h and 7456h. It represents “seconds” as the unit used in all cases.

Object Description

Index	7458h
Name	PID Physical Unit Timing
Object Type	ARRAY
Data Type	UNSIGNED32

Entry Description

Sub-Index	0h
Description	Largest sub-index supported
Access	RO
PDO Mapping	No
Value Range	2
Default Value	2

Sub-Index	1h to 2h (x = 1 or 2)
Description	PIDx Physical Unit Timing
Access	RO
PDO Mapping	No
Value Range	0003 0000h
Default Value	0003 0000h (seconds)

3.3.36. Object 6459h: PID Decimal Digits Timing

This object describes the number of digits following the decimal point (i.e. resolution) of the PID timing data, which is interpreted with data type Integer16 in objects 7452h, 7454h and 7456h.

Object Description

Index	6459h
Name	PID Decimal Digits Timing
Object Type	ARRAY
Data Type	UNSIGNED8

Entry Description

Sub-Index	0h
Description	Largest sub-index supported
Access	RO
PDO Mapping	No
Value Range	2
Default Value	2

Sub-Index	1h to 2h (x = 1 or 2)
Description	PIDx Decimal Digits Timing
Access	RW
PDO Mapping	No
Value Range	0 to 4
Default Value	3 [ms]

3.4. MANUFACTURER OBJECTS

Index (hex)	Object	Object Type	Data Type	Access	PDO Mapping
2020	DI Pull Up/Down Mode 1 Input Line	ARRAY	UNSIGNED8	RW	No
2030	DI Debounce Filter 1 Input Line	ARRAY	UNSIGNED8	RW	No
2100	AI Input Range	ARRAY	UNSIGNED8	RW	No
2101	AI Number of Pulses Per Revolution	ARRAY	UNSIGNED16	RW	No
2102	AI Decimal Digits FV	ARRAY	UNSIGNED8	RW	No
2103	AI Filter Frequency for ADC	ARRAY	UNSIGNED8	RW	No
2110	AI Error Detect Enable	ARRAY	BOOLEAN	RW	No
2111	AI Error Clear Hysteresis	ARRAY	INTEGER16	RW	No
2112	AI Error Reaction Delay	ARRAY	UNSIGNED16	RW	No
2120	AI Third-Order Filter Power	ARRAY	UNSIGNED16	RW	No
2121	AI Third-Order Filter Input Coefficient N0	ARRAY	INTEGER16	RW	No
2122	AI Third-Order Filter Input Coefficient N1	ARRAY	INTEGER16	RW	No
2123	AI Third-Order Filter Input Coefficient N2	ARRAY	INTEGER16	RW	No
2124	AI Third-Order Filter Input Coefficient N3	ARRAY	INTEGER16	RW	No
2125	AI Third-Order Filter Output Coefficient N1	ARRAY	INTEGER16	RW	No
2126	AI Third-Order Filter Output Coefficient N2	ARRAY	INTEGER16	RW	No
2127	AI Third-Order Filter Output Coefficient N3	ARRAY	INTEGER16	RW	No
2220	DO Hotshot Current 1 Output Line	ARRAY	INTEGER16	RW	No
2221	DO Hold Current 1 Output Line	ARRAY	INTEGER16	RW	No
2222	DO Hotshot Time 1 Output Line	ARRAY	UNSIGNED16	RW	No
2223	DO Blink Rate 1 Output Line	ARRAY	UNSIGNED16	RW	No
2300	AO Override Field Value	ARRAY	INTEGER16	RW	No
2310	AO Error Detect Enable	ARRAY	BOOLEAN	RW	No
2311	AO Error Clear Hysteresis	ARRAY	INTEGER16	RW	No
2312	AO Error Reaction Delay	ARRAY	UNSIGNED16	RW	No
2320	AO Dither Frequency	ARRAY	UNSIGNED16	RW	No
2321	AO Dither Amplitude	ARRAY	UNSIGNED16	RW	No
2330	AO Ramp Up	ARRAY	UNSIGNED16	RW	No
2331	AO Ramp Down	ARRAY	UNSIGNED16	RW	No
2340	AO Control Input Source	ARRAY	UNSIGNED8	RW	No
2341	AO Control Input Number	ARRAY	UNSIGNED8	RW	No
2342	AO Control Input Response	ARRAY	UNSIGNED8	RW	No
2350	AO Enable Input Source	ARRAY	UNSIGNED8	RW	No
2351	AO Enable Input Number	ARRAY	UNSIGNED8	RW	No
2352	AO Enable Input Response	ARRAY	UNSIGNED8	RW	No
2360	AO Override Input Source	ARRAY	UNSIGNED8	RW	No
2361	AO Override Input Number	ARRAY	UNSIGNED8	RW	No
2362	AO Override Input Response	ARRAY	UNSIGNED8	RW	No
2370	AO Feedback Field Value	ARRAY	INTEGER16	RO	Yes
2380	AO Output Frequency	ARRAY	UNSIGNED16	RW	No
2381	AO Current Sense Averaging Time	ARRAY	UNSIGNED16	RW	No
2382	AO Current PID Proportional Gain	ARRAY	FLOAT32	RW	No
2382	AO Current PID Integral Time	ARRAY	FLOAT32	RW	No
2382	AO Current PID Derivative Time	ARRAY	FLOAT32	RW	No

2450	PID Tolerance	ARRAY	INTEGER16	RW	No
2451	PID Integral Gain	ARRAY	INTEGER16	RW	No
2452	PID Derivative Gain	ARRAY	INTEGER16	RW	No
2453	PID Target Source	ARRAY	UNSIGNED8	RW	No
2454	PID Target Number	ARRAY	UNSIGNED8	RW	No
2455	PID Feedback Source	ARRAY	UNSIGNED8	RW	No
2456	PID Feedback Number	ARRAY	UNSIGNED8	RW	No
2457	PID Control Response	ARRAY	UNSIGNED8	RW	No
2460	PID Output Field Value	ARRAY	INTEGER16	RO	Yes
2500	EC Extra Received Process Value	ARRAY	INTEGER16	RW	Yes
2502	EC Decimal Digits PV	ARRAY	UNSIGNED8	RW	No
2520	EC Scaling 1 PV	ARRAY	INTEGER16	RW	No
2522	EC Scaling 2 PV	ARRAY	INTEGER16	RW	No
30z0	LTz Input X-Axis Source	VAR	UNSIGNED8	RW	No
30z1	LTz Input X-Axis Number	VAR	UNSIGNED8	RW	No
30z2	LTz X-Axis Decimal Digits PV	VAR	UNSIGNED8	RW	No
30z3	LTz Y-Axis Decimal Digits PV	VAR	UNSIGNED8	RW	No
30z4	LTz Point Response	ARRAY	UNSIGNED8	RW	No
30z5	LTz Point X-Axis PV	ARRAY	INTEGER16	RW	No
30z6	LTz Point Y-Axis PV	ARRAY	INTEGER16	RW	No
30z7	LTz Output Y-Axis PV	ARRAY	INTEGER16	RO	Yes
4000	Logic Block Enable	ARRAY	UNSIGNED8	RW	No
4010	Logic Block Selected Table	ARRAY	UNSIGNED8	RW	No
4020	Logic Output Process Value	ARRAY	INTEGER16	RO	Yes
4x01	LBx Lookup Table Number	ARRAY	UNSIGNED8	RW	No
4x02	LBx Function Logical Operator	ARRAY	UNSIGNED8	RW	No
4x11	Logic Block A Function A Condition 1	ARRAY	RECORD	RW	No
4x12	Logic Block A Function A Condition 2	ARRAY	RECORD	RW	No
4x13	Logic Block A Function A Condition 3	ARRAY	RECORD	RW	No
4x21	Logic Block A Function B Condition 1	ARRAY	RECORD	RW	No
4x22	Logic Block A Function B Condition 2	ARRAY	RECORD	RW	No
4x23	Logic Block A Function B Condition 3	ARRAY	RECORD	RW	No
4x31	Logic Block A Function C Condition 1	ARRAY	RECORD	RW	No
4x32	Logic Block A Function C Condition 2	ARRAY	RECORD	RW	No
4x33	Logic Block A Function C Condition 3	ARRAY	RECORD	RW	No
5010	Constant Field Value	ARRAY	FLOAT32	RW	No
5020	Power Supply Field Value	VAR	FLOAT32	RO	Yes
5030	Processor Temperature Field Value	VAR	FLOAT32	RO	Yes
5555	Start in Operational Mode	VAR	BOOLEAN	RW	No

Where z = 1 to 6 and x = 1 to 4

3.4.1. Object 2020h: DI Pullup/Down Mode 1 Input Line

This object determines how the state read on the input pin corresponds to the logic state, in conjunction with application object 6020h, as defined in Table 3. The options for this object are listed in Table 1, and the controller will adjust the input hardware according to what is specified.

Object Description

Index	2020h
Name	DI Pullup/Down Mode 1 Input Line
Object Type	ARRAY
Data Type	UNSIGNED8

Entry Description

Sub-Index	0h
Description	Largest sub-index supported
Access	RO
PDO Mapping	No
Value Range	1
Default Value	1

Sub-Index	1h
Description	Digital Input 1 Pullup/Down
Access	RW
PDO Mapping	No
Value Range	See Table 1
Default Value	0 (pullup/down disabled)

3.4.2. Object 2030h: DI Debounce Filter 1 Input Line

This object will debounce the input signal applied on a single digital input as shown in Figure 4. The options for this object are listed in Table 2.

Object Description

Index	2020h
Name	DI Debounce Filter 1 Input Line
Object Type	ARRAY
Data Type	UNSIGNED8

Entry Description

Sub-Index	0h
Description	Largest sub-index supported
Access	RO
PDO Mapping	No
Value Range	1
Default Value	1

Sub-Index	1h
Description	Digital Input 1 Pullup/Down
Access	RW
PDO Mapping	No
Value Range	See Table 2
Default Value	2 [Filter 1.78 us]

3.4.3. Object 2100h: AI Input Range

This object, in conjunction with 6110h AI Sensor Type, defines the analog input defaults (Table 10) and allowable ranges (Table 11) for objects 2111h, 7120h, 7122h, 7148h and 7149h. The number and types of ranges will vary according to what type of sensor is connected to the input, as described in Table 6.

Object Description

Index	2100h
Name	AI Input Range
Object Type	ARRAY
Data Type	UNSIGNED8

Entry Description

Sub-Index	0h
Description	Largest sub-index supported
Access	RO
PDO Mapping	No
Value Range	1
Default Value	1

Sub-Index	1h
Description	AI1 Range
Access	RW
PDO Mapping	No
Value Range	See Table 6
Default Value	2 [0-5V]

3.4.4. Object 2101h: AI Number of Pulses Per Revolution

This object is only used when a “Frequency” input type has been selected by object 6110h. The controller will automatically convert frequency measurement from Hz to RPM when a non-zero value is specified. In this case, objects 2111h, 7120h, 7122h, 7148h and 7149h will be interpreted as RPM data. Object 2100h AI Input Range must still be specified in Hertz, and should be selected according to the expected frequencies that the RPM sensor will operate in.

Object Description

Index	2101h
Name	AI Number of Pulses Per Revolution
Object Type	ARRAY
Data Type	UNSIGNED16

Entry Description

Sub-Index	0h
Description	Largest sub-index supported
Access	RO
PDO Mapping	No
Value Range	1
Default Value	1

Sub-Index	1h
Description	AI1 Pulses per Revolution
Access	RW
PDO Mapping	No
Value Range	0 to 1000
Default Value	1

3.4.5. Object 2102h: AI Decimal Digits FV

This object describes the number of digits following the decimal point (i.e. resolution) of the input data, which is interpreted with data type Integer16 in the field value object.

Example: A field value of 1.230 (Float) will be coded as 1230 in Integer16 format if the number of decimal digits is set to 3.

In addition to the FV object 7100h, objects 2111h, 7120h, 7122h, 7148h and 7149h will also be specified with this resolution. This object is read-only, and will be automatically adjusted by the controller as per Table 9 depending on the analog input type and range that has been selected.

Object Description

Index	2102h
Name	AI Decimal Digits FV
Object Type	ARRAY
Data Type	UNSIGNED8

Entry Description

Sub-Index	0h
Description	Largest sub-index supported
Access	RO
PDO Mapping	No
Value Range	1
Default Value	1

Sub-Index	1h
Description	AI1 Decimal Digits FV
Access	RO
PDO Mapping	No
Value Range	See Table 9
Default Value	3 [Volt to mV]

3.4.6. Object 2103h: AI Filter Frequency for ADC

This object is used to specify the cutoff filter frequency for the ADC peripheral on the processor. The analog-to-digital converter is used with analog input types: voltage; current; and resistive. It is also used to measure: analog output current feedback; power supply voltage, and processor temperature. The available filters are listed in Table 7.

Object Description

Index	2104h
Name	AI Filter Frequency for ADC
Object Type	ARRAY
Data Type	UNSIGNED8

Entry Description

Sub-Index	0h
Description	Largest sub-index supported
Access	RO
PDO Mapping	No
Value Range	1
Default Value	1

Sub-Index	1h
Description	ADC Filter Frequency
Access	RW
PDO Mapping	No
Value Range	See Table 7
Default Value	1 [Filter 50Hz]

3.4.7. Object 2110h: AI Error Detect Enable

This object enables error detection and reaction associated with the analog input function block. When disabled, the input will not generate an EMCY code in object 1003h Pre-Defined Error Field, nor will it disable any output controlled by the input should the input go out of range as defined by the objects 7148h AI Span Start and 7149h AI Span End.

Object Description

Index	2110h
Name	AI Error Detect Enable
Object Type	ARRAY
Data Type	BOOLEAN

Entry Description

Sub-Index	0h
Description	Largest sub-index supported
Access	RO
PDO Mapping	No
Value Range	1
Default Value	1

Sub-Index	1h
Description	AI1 Error Detect Enable
Access	RW
PDO Mapping	No
Value Range	0 (FALSE) or 1 (TRUE)
Default Value	1 [TRUE]

3.4.8. Object 2111h: AI Error Clear Hysteresis

This object is used to prevent rapid activation/clearing of an input fault flag, and sending of object 1003h to the CANopen ® network. Once the input has gone above/below the thresholds that define the valid operating range, it must come back into range minus/plus this value to clear the fault. It is scaled in the physical unit of the FV, i.e. object 2102h applies to this object.

Object Description

Index	2111h
Name	AI Error Clear Hysteresis
Object Type	ARRAY
Data Type	INTEGER16

Entry Description

Sub-Index	0h
Description	Largest sub-index supported
Access	RO
PDO Mapping	No
Value Range	1
Default Value	1

Sub-Index	1h
Description	AI1 Error Clear Hysteresis
Access	RW
PDO Mapping	No
Value Range	See Table 11
Default Value	100 [mV]

3.4.9. Object 2112h: AI Error Reaction Delay

This object is used to filter out spurious signals and to prevent saturating the CANopen ® network with broadcasts of object 1003h as the fault is set/cleared. Before the fault is recognized (i.e. the EMCY code is added to the pre-defined error field list), it must remain active throughout the period of time defined in this object. The physical unit for this object is milliseconds.

Object Description

Index	2112h
Name	AI Error Reaction Delay
Object Type	ARRAY
Data Type	UNSIGNED16

Entry Description

Sub-Index	0h
Description	Largest sub-index supported
Access	RO
PDO Mapping	No
Value Range	1
Default Value	1

Sub-Index	1h
Description	AI1 Error Reaction Delay
Access	RW
PDO Mapping	No
Value Range	0 to 60,000
Default Value	1000 [ms]

3.4.10. Object 2120h: AI Third-Order Filter Power

Third order filtering of the input data is done using 16-bit fixed point math. This object tells the controller the shift value (i.e. 2^x) that was used when the coefficients were selected. See Section 1.3 for more information on the third-order low pass filter.

Object Description

Index	2120h
Name	AI Third-Order Filter Power
Object Type	ARRAY
Data Type	UNSIGNED16

Entry Description

Sub-Index	0h
Description	Largest sub-index supported
Access	RO
PDO Mapping	No
Value Range	1
Default Value	1

Sub-Index	1h
Description	AI1 Third-Order Filter Power
Access	RW
PDO Mapping	No
Value Range	0 to 16
Default Value	10 [$2^{10} = 1024$]

3.4.11. Object 2121h: AI Third-Order Filter Input Coefficient N0

3.4.12. Object 2122h: AI Third-Order Filter Input Coefficient N1

3.4.13. Object 2123h: AI Third-Order Filter Input Coefficient N2

3.4.14. Object 2124h: AI Third-Order Filter Input Coefficient N3

These objects specify the 16-bit shifted input co-efficient values used in the third-order low pass filter calculation described in Section 1.3. They are all defined with a right shift value of 2^{10} . Since coefficient N3 is set to zero, the default filter is a second-order low pass.

Object Description

Index	2121h to 2124h (x = 0 to 3)
Name	AI 3 rd Order Filter Input Coefficient Nx
Object Type	ARRAY
Data Type	INTEGER16

Entry Description

Sub-Index	0h
Description	Largest sub-index supported
Access	RO
PDO Mapping	No
Value Range	1
Default Value	1

Sub-Index	1h
Description	AI1 3 rd Order Filter Input Coeff Nx
Access	RW
PDO Mapping	No
Value Range	-10000 to 10000
Default Value	N0=120, N1=241, N2=120, N3=0

3.4.15. Object 2125h: AI Third-Order Filter Output Coefficient N1

3.4.16. Object 2126h: AI Third-Order Filter Output Coefficient N2

3.4.17. Object 2127h: AI Third-Order Filter Output Coefficient N3

These objects specify the 16-bit shifted output co-efficient values used in the third-order low pass filter calculation described in Section 1.3. They are all defined with a right shift value of 2^{10} . Since coefficient N3 is set to zero, the default filter is a second-order low pass.

Object Description

Index	2125h to 2127h (x = 1 to 3)
Name	AI 3 rd Order Filter Output Coefficient Nx
Object Type	ARRAY
Data Type	INTEGER16

Entry Description

Sub-Index	0h
Description	Largest sub-index supported
Access	RO
PDO Mapping	No
Value Range	1
Default Value	1

Sub-Index	1h
Description	AI1 3 rd Order Filter Output Coeff Nx
Access	RW
PDO Mapping	No
Value Range	-10000 to 10000
Default Value	N1=704, N2=-164, N3=0

3.4.18. Object 2220h: DO Hotshot Current 1 Output Line

This object is used to define the hotshot current that will be applied for the hotshot time when an output configured as a digital hotshot is turned ON. See Figure 9 for more information. The physical unit is mA, and it uses the same resolution as the AO Output FV, so object 6332 AO Decimal Digits FV applies.

Object Description

Index	2220h
Name	DO Hotshot Current 1 Output Line
Object Type	ARRAY
Data Type	INTEGER16

Entry Description

Sub-Index	0h
Description	Largest sub-index supported
Access	RO
PDO Mapping	No
Value Range	2
Default Value	2

Sub-Index	1h to 2h (x = 1 or 2)
Description	DOx Hotshot Current
Access	RW
PDO Mapping	Yes
Value Range	2221h (Hold Current) to I _{max} (3A)
Default Value	2000 [mA]

3.4.19. Object 2221h: DO Hold Current 1 Output Line

This object is used to define the hold current that will be maintained after the hotshot time while an output configured as a digital hotshot is ON. See Figure 9 for more information. The physical unit is mA, and it uses the same resolution as the AO Output FV, so object 6332 AO Decimal Digits FV applies.

Object Description

Index	2221h
Name	DO Hold Current 1 Output Line
Object Type	ARRAY
Data Type	INTEGER16

Entry Description

Sub-Index	0h
Description	Largest sub-index supported
Access	RO
PDO Mapping	No
Value Range	2
Default Value	2

Sub-Index	1h to 2h (x = 1 or 2)
Description	DOx Hold Current
Access	RW
PDO Mapping	Yes
Value Range	0 to 2220h (Hotshot Current)
Default Value	500 [mA]

3.4.20. Object 2222h: DO Hold Time 1 Output Line

This object is used to define the time that the hotshot current will be applied when an output configured as a digital hotshot is turned ON. See Figure 9 for more information. The physical unit is milliseconds.

Object Description

Index	2222h
Name	DO Hotshot Time 1 Output Line
Object Type	ARRAY
Data Type	UNSIGNED16

Entry Description

Sub-Index	0h
Description	Largest sub-index supported
Access	RO
PDO Mapping	No
Value Range	2
Default Value	2

Sub-Index	1h to 2h (x = 1 or 2)
Description	DOx Hotshot Time
Access	RW
PDO Mapping	Yes
Value Range	0 to 60,000
Default Value	1000 [ms]

3.4.21. Object 2223h: DO Blink Rate 1 Output Line

This object is used only when an On/Off digital output (does not apply with a digital hotshot) has been specified for a blinking response by object 6240h DO Polarity. While the DO is commanded ON, it will blink on/off at the rate specified in this object. (On for x, then off for x). The physical unit is milliseconds.

Object Description

Index	2223h
Name	DO Blink Rate1 Output Line
Object Type	ARRAY
Data Type	UNSIGNED16

Entry Description

Sub-Index	0h
Description	Largest sub-index supported
Access	RO
PDO Mapping	No
Value Range	2
Default Value	2

Sub-Index	1h to 2h (x = 1 or 2)
Description	DOx Blink Rate
Access	RW
PDO Mapping	Yes
Value Range	0 to 60,000
Default Value	500 [ms]

3.4.22. Object 2300h: AO Override Field Value

This object contains the pre-defined field value of an analog output when an override condition is active. It will be scaled in the physical unit of the output, dependent on type, with the resolution defined in object 6332h AO Decimal Digits FV.

Object Description

Index	2300h
Name	AO Override FV
Object Type	ARRAY
Data Type	INTEGER16

Entry Description

Sub-Index	0h
Description	Largest sub-index supported
Access	RO
PDO Mapping	No
Value Range	2
Default Value	2

Sub-Index	1h to 2h (x = 1 or 2)
Description	AOx Override FV
Access	RW
PDO Mapping	No
Value Range	Dependent on type (see Table 14)
Default Value	750 [mA]

3.4.23. Object 2310h: AO Error Detect Enable

This object enables error detection and reaction associated with the analog output function block. When disabled, the input will not generate an EMCY code in object 1003h Pre-Defined Error Field should the control detect an open/short circuit at the load.

Object Description

Index	2310h
Name	AO Error Detect Enable
Object Type	ARRAY
Data Type	BOOLEAN

Entry Description

Sub-Index	0h
Description	Largest sub-index supported
Access	RO
PDO Mapping	No
Value Range	2
Default Value	2

Sub-Index	1h or 2h (x = 1 or 2)
Description	AOx Error Detect Enable
Access	RW
PDO Mapping	No
Value Range	0 (FALSE) or 1 (TRUE)
Default Value	1 [TRUE]

3.4.24. Object 2311h: AO Error Clear Hysteresis

This object is used to define the absolute difference that can be tolerated between the target output (as commanded by the control input) and the measured feedback. Any difference outside of the value will flag an open or short circuit fault. It is scaled in the physical unit of the output FV, i.e. object 6332h applies to this object.

Object Description

Index	2311h
Name	AI Error Clear Hysteresis
Object Type	ARRAY
Data Type	INTEGER16

Entry Description

Sub-Index	0h
Description	Largest sub-index supported
Access	RO
PDO Mapping	No
Value Range	2
Default Value	2

Sub-Index	1h or 2h (x = 1 or 2)
Description	AOx Error Clear Hysteresis
Access	RW
PDO Mapping	No
Value Range	0 to 10% of 7321h or 7323h, whichever is larger
Default Value	100 [mA]

3.4.25. Object 2312h: AO Error Reaction Delay

This object is used to filter out spurious signals and to prevent saturating the CANopen ® network with broadcasts of object 1003h as the fault is set/cleared. Before the fault is recognized (i.e. the EMCY code is added to the pre-defined error field list), it must remain active throughout the period of time defined in this object. The physical unit for this object is milliseconds.

Object Description

Index	2312h
Name	AO Error Reaction Delay
Object Type	ARRAY
Data Type	UNSIGNED16

Entry Description

Sub-Index	0h
Description	Largest sub-index supported
Access	RO
PDO Mapping	No
Value Range	2
Default Value	2

Sub-Index	1h or 2h (x = 1 or 2)
Description	AOx Error Reaction Delay
Access	RW
PDO Mapping	No
Value Range	0 to 60,000
Default Value	1000 [ms]

3.4.26. Object 2320h: AO Dither Frequency

This object defines the low frequency that is superimposed on the high output frequency (object 2380h) when an AO is configured as a current output. The dither frequency should be selected such that the valve will respond immediately to small changes in current. There is only one dither timer available on the processor, so both AO1 and AO2 use the same frequency as defined in sub-index 1. The physical unit for this object is Hertz.

Object Description

Index	2320h
Name	AO Dither Frequency
Object Type	ARRAY
Data Type	UNSIGNED16

Entry Description

Sub-Index	0h
Description	Largest sub-index supported
Access	RO
PDO Mapping	No
Value Range	2
Default Value	2

Sub-Index	1h
Description	AO1 Dither Frequency
Access	RW
PDO Mapping	No
Value Range	50 to 1000
Default Value	200 [Hz]

Sub-Index	2h
Description	AO2 Dither Frequency
Access	RO
PDO Mapping	No
Value Range	2320h sub-index 1
Default Value	200 [Hz]

3.4.27. Object 2321h: AO Dither Amplitude

This object defines the amplitude of the low frequency signal that is superimposed on the output when an AO is configured as a current output. A zero value in this object disables the dithering feature. Note, the actual dither amplitude will not match exactly what is defined in this object, as it will be dependent on the inductance of the coil. Rather, this object should be adjusted such that the valve will respond immediately to small changes in current. The physical unit for this object is milliamps. Object 6332h does NOT apply.

Object Description

Index	2321h
Name	AO Dither Amplitude
Object Type	ARRAY
Data Type	UNSIGNED16

Entry Description

Sub-Index	0h
Description	Largest sub-index supported
Access	RO
PDO Mapping	No
Value Range	2
Default Value	2

Sub-Index	1h or 2h (x = 1 or 2)
Description	AOx Dither Amplitude
Access	RW
PDO Mapping	No
Value Range	0 to 500
Default Value	0 [mA] (dithering disabled)

3.4.28. Object 2330h: AO Ramp Up

This object defines the time it will take to ramp from the minimum output PV to the maximum as defined by objects 7321h and 7323h. It can be used to soften the response to a step change at the input. The physical unit for this object is milliseconds.

Object Description

Index	2330h
Name	AO Ramp Up
Object Type	ARRAY
Data Type	UNSIGNED16

Entry Description

Sub-Index	0h
Description	Largest sub-index supported
Access	RO
PDO Mapping	No
Value Range	2
Default Value	2

Sub-Index	1h or 2h (x = 1 or 2)
Description	AOx Ramp Up
Access	RW
PDO Mapping	No
Value Range	0 to 60,000
Default Value	1000 [ms]

3.4.29. Object 2331h: AO Ramp Down

This object defines the time it will take to ramp from the maximum output PV to the minimum as defined by objects 7321h and 7323h. It can be used to soften the response to a step change at the input. The physical unit for this object is milliseconds.

Object Description

Index	2330h
Name	AO Ramp Down
Object Type	ARRAY
Data Type	UNSIGNED16

Entry Description

Sub-Index	0h
Description	Largest sub-index supported
Access	RO
PDO Mapping	No
Value Range	2
Default Value	2

Sub-Index	1h or 2h (x = 1 or 2)
Description	AOx Ramp Down
Access	RW
PDO Mapping	No
Value Range	0 to 60,000
Default Value	1000 [ms]

3.4.30. Object 2340h: AO Control Input Source

This object defines the type of input that will be used to control the analog (or digital) output as shown in the logic flowchart in Figure 13. The available control sources on the 1i2o controller are listed in Table 15. Not all sources would make sense to control the AO, and it is the user's responsibility to select a source that makes sense for the application.

Object Description

Index	2340h
Name	AO Control Input Source
Object Type	ARRAY
Data Type	UNSIGNED8

Entry Description

Sub-Index	0h
Description	Largest sub-index supported
Access	RO
PDO Mapping	No
Value Range	2
Default Value	2

Sub-Index	1h or 2h (x = 1 or 2)
Description	AOx Control Input Source
Access	RW
PDO Mapping	No
Value Range	See Table 15
Default Value	2 (analog input function block)

3.4.31. Object 2341h: AO Control Input Number

This object defines the number of the source that will be used to control the analog (or digital) output as shown in the logic flowchart in Figure 13. The available control numbers are dependent on the source selected, as shown in Table 16. Once selected, the control represents the process value (X-Axis input) in Figure 11. Objects 6302h, 7320h, 7322h should therefore be updated to match the scaling limits defined by the control source/number, as listed in Table 17.

Object Description

Index	2341h
Name	AO Control Input Number
Object Type	ARRAY
Data Type	UNSIGNED8

Entry Description

Sub-Index	0h
Description	Largest sub-index supported
Access	RO
PDO Mapping	No
Value Range	2
Default Value	2

Sub-Index	1h or 2h (x = 1 or 2)
Description	AOx Control Input Number
Access	RW
PDO Mapping	No
Value Range	See Table 16
Default Value	1 (analog input 1)

3.4.32. Object 2342h: AO Control Response

This object defines the response profile of the analog output FV with respect to the input PV (as selected by objects 2340h/2341h.) Normally it will follow the profile shown in Figure 11. However, in some cases the offset will be disabled (i.e. output at 0) when the PV is below 7320h Scaling 1 PV or alternatively above the 7322h Scaling 2 PV, as shown in Figure 12. The options for this object are listed in Table 18.

Object Description

Index	2342h
Name	AO Control Response
Object Type	ARRAY
Data Type	UNSIGNED8

Entry Description

Sub-Index	0h
Description	Largest sub-index supported
Access	RO
PDO Mapping	No
Value Range	2
Default Value	2

Sub-Index	1h
Description	AO1 Control Response
Access	RW
PDO Mapping	No
Value Range	See Table 18
Default Value	1 (off below scaling 1 PV)

Sub-Index	2h
Description	AO2 Control Response
Access	RW
PDO Mapping	No
Value Range	See Table 18
Default Value	2 (off above scaling 2 PV)

3.4.33. Object 2350h: AO Enable Input Source

This object defines the type of input that will be used to enable/disable the analog (or digital) output as shown in the logic flowchart in Figure 13. The available control sources on the 1i2o controller are listed in Table 15. Not all sources would make sense to enable the AO, and it is the user's responsibility to select a source that makes sense for the application.

Object Description

Index	2350h
Name	AO Enable Input Source
Object Type	ARRAY
Data Type	UNSIGNED8

Entry Description

Sub-Index	0h
Description	Largest sub-index supported
Access	RO
PDO Mapping	No
Value Range	2
Default Value	2

Sub-Index	1h or 2h (x = 1 or 2)
Description	AOx Enable Input Source
Access	RW
PDO Mapping	No
Value Range	See Table 15
Default Value	0 (control not used)

3.4.34. Object 2351h: AO Enable Input Number

This object defines the number of the source that will be used to enable/disable the analog (or digital) output as shown in the logic flowchart in Figure 13. The available control numbers are dependent on the source selected, as shown in Table 16. Once selected, the control will be interpreted as a digital input, per the response shown in Figure 5.

Object Description

Index	2351h
Name	AO Enable Input Number
Object Type	ARRAY
Data Type	UNSIGNED8

Entry Description

Sub-Index	0h
Description	Largest sub-index supported
Access	RO
PDO Mapping	No
Value Range	2
Default Value	2

Sub-Index	1h or 2h (x = 1 or 2)
Description	AOx Enable Input Number
Access	RW
PDO Mapping	No
Value Range	See Table 16
Default Value	0 (null source selected)

3.4.35. Object 2352h: AO Enable Response

This object determines if the input will act as an enable or safety interlock (i.e. input must be ON to engage the output) or a disable signal (i.e. the output will shutoff when the input is ON.) The options for this object are listed in Table 20.

Object Description

Index	2352h
Name	AO Enable Response
Object Type	ARRAY
Data Type	UNSIGNED8

Entry Description

Sub-Index	0h
Description	Largest sub-index supported
Access	RO
PDO Mapping	No
Value Range	2
Default Value	2

Sub-Index	1h or 2h (x = 1 or 2)
Description	AOx Enable Response
Access	RW
PDO Mapping	No
Value Range	See Table 20
Default Value	1 (disable when input on)

3.4.36. Object 2360h: AO Override Input Source

This object defines the type of input that will be used to active the override value for the analog (or digital) output as shown in the logic flowchart in Figure 13. The available control sources on the 1i2o controller are listed in Table 15. Not all sources would make sense to enable the AO, and it is the user's responsibility to select a source that makes sense for the application.

Object Description

Index	2360h
Name	AO Override Input Source
Object Type	ARRAY
Data Type	UNSIGNED8

Entry Description

Sub-Index	0h
Description	Largest sub-index supported
Access	RO
PDO Mapping	No
Value Range	2
Default Value	2

Sub-Index	1h or 2h (x = 1 or 2)
Description	AOx Override Input Source
Access	RW
PDO Mapping	No
Value Range	See Table 15
Default Value	0 (control not used)

3.4.37. Object 2361h: AO Override Input Number

This object defines the number of the source that will be used to override the analog (or digital) output as shown in the logic flowchart in Figure 13. The available control numbers are dependent on the source selected, as shown in Table 16. Once selected, the control will be interpreted as a digital input, per the response shown in Figure 5.

Object Description

Index	2361h
Name	AO Override Input Number
Object Type	ARRAY
Data Type	UNSIGNED8

Entry Description

Sub-Index	0h
Description	Largest sub-index supported
Access	RO
PDO Mapping	No
Value Range	2
Default Value	2

Sub-Index	1h or 2h (x = 1 or 2)
Description	AOx Override Input Number
Access	RW
PDO Mapping	No
Value Range	See Table 16
Default Value	0 (null source selected)

3.4.38. Object 2362h: AO Override Response

This object determines how the override command will respond to the input state. The options for this object are listed in Table 21.

Object Description

Index	2362h
Name	AO Override Response
Object Type	ARRAY
Data Type	UNSIGNED8

Entry Description

Sub-Index	0h
Description	Largest sub-index supported
Access	RO
PDO Mapping	No
Value Range	2
Default Value	2

Sub-Index	1h or 2h (x = 1 or 2)
Description	AOx Override Response
Access	RW
PDO Mapping	No
Value Range	See Table 20
Default Value	0 (override when input on)

3.4.39. Object 2370h: AO Feedback Field Value

This read-only object reflects the actual measured current feedback of an analog output. For other output types (i.e. voltage, PWM or digital,) it will reflect the target Output FV or State (for DO type) based on PV vs. FV calculations (see Figure 11) and applied ramps. It can be mapped to a PDO for diagnostic purposes. It will be scaled in the physical unit of the output, dependent on type, with the resolution defined in object 6332h AO Decimal Digits FV.

Object Description

Index	2370h
Name	AO Feedback FV
Object Type	ARRAY
Data Type	INTEGER16

Entry Description

Sub-Index	0h
Description	Largest sub-index supported
Access	RO
PDO Mapping	No
Value Range	2
Default Value	2

Sub-Index	1h or 2h (x = 1 or 2)
Description	AOx Feedback FV
Access	RW
PDO Mapping	No
Value Range	Dependent on type (see Table 14)
Default Value	No

3.4.40. Object 2380h: AO Output Frequency

This object is meant to be used only with analog output type PWM. It defines the fixed output frequency that will be used, as the duty cycle will be the Output FV. It can be changed with other output types (i.e. current or voltage), but Axiomatic will no longer guarantee the accuracy or responsiveness of the output as the frequency decreases. Very low output frequencies (i.e. <2500Hz) can destabilize the current PID loop. There is only one output PWM timer available on the processor, so both AO1 and AO2 use the same frequency as defined in sub-index 1. The physical unit for this object is Hertz.

Object Description

Index	2380h
Name	AO Output Frequency
Object Type	ARRAY
Data Type	UNSIGNED16

Entry Description

Sub-Index	0h
Description	Largest sub-index supported
Access	RO
PDO Mapping	No
Value Range	2
Default Value	2

Sub-Index	1h
Description	AO1 Output Frequency
Access	RW
PDO Mapping	No
Value Range	1 to 25,000
Default Value	25000 [Hz]

Sub-Index	2h
Description	AO2 Output Frequency
Access	RO
PDO Mapping	No
Value Range	2380h sub-index 1
Default Value	25000 [Hz]

3.4.41. Object 2381h: AO Current Sensor Averaging Time

This object defines how frequently the current feedback measurement will be taken. The physical unit for this object is milliseconds.

Object Description

Index	2381h
Name	AO Current Sensor Averaging Time
Object Type	ARRAY
Data Type	UNSIGNED16

Entry Description

Sub-Index	0h
Description	Largest sub-index supported
Access	RO
PDO Mapping	No
Value Range	2
Default Value	2

Sub-Index	1h or 2h (x = 1 or 2)
Description	AOx Current Sensor Averaging Time
Access	RW
PDO Mapping	No
Value Range	1 to 1000
Default Value	100 [ms]

3.4.42. Object 2382h: AO Current PID Proportional Gain

This object has been factory calibrated, and should be changed with caution. Axiomatic will no longer guarantee the accuracy or responsiveness of the current output when this value is changed. It is provided as a writeable object in case the output frequency is changed and the user wants to try and optimize the current PID loop. Axiomatic does not recommend this.

Object Description

Index	2382h
Name	AO Current PID Proportional Gain
Object Type	ARRAY
Data Type	FLOAT32

Entry Description

Sub-Index	0h
Description	Largest sub-index supported
Access	RO
PDO Mapping	No
Value Range	2
Default Value	2

Sub-Index	1h or 2h (x = 1 or 2)
Description	AOx Current Sensor Averaging Time
Access	RW
PDO Mapping	No
Value Range	FLOAT32
Default Value	0.8

3.4.43. Object 2383h: AO Current PID Integral Time

This object has been factory calibrated, and should be changed with caution. Axiomatic will no longer guarantee the accuracy or responsiveness of the current output when this value is changed. It is provided as a writeable object in case the output frequency is changed and the user wants to try and optimize the current PID loop. Axiomatic does not recommend this.

Object Description

Index	2383h
Name	AO Current PID Integral Time
Object Type	ARRAY
Data Type	FLOAT32

Entry Description

Sub-Index	0h
Description	Largest sub-index supported
Access	RO
PDO Mapping	No
Value Range	2
Default Value	2

Sub-Index	1h or 2h (x = 1 or 2)
Description	AOx Current PID Integral Time
Access	RW
PDO Mapping	No
Value Range	FLOAT32
Default Value	0.03

3.4.44. Object 2384h: AO Current PID Derivative Time

This object has been factory calibrated, and should be changed with caution. Axiomatic will no longer guarantee the accuracy or responsiveness of the current output when this value is changed. It is provided as a writeable object in case the output frequency is changed and the user wants to try and optimize the current PID loop. Axiomatic does not recommend this.

Object Description

Index	2384h
Name	AO Current PID Derivative Time
Object Type	ARRAY
Data Type	FLOAT32

Entry Description

Sub-Index	0h
Description	Largest sub-index supported
Access	RO
PDO Mapping	No
Value Range	2
Default Value	2

Sub-Index	1h or 2h (x = 1 or 2)
Description	AOx Current PID Derivative Time
Access	RW
PDO Mapping	No
Value Range	FLOAT32
Default Value	0.001

3.4.45. Object 2450h: PID Tolerance

This object defines the allowable absolute difference between the target and the feedback, below which the error will be interpreted as zero (i.e. PID output stops changing). The physical unit for this object is percentage, and the value is always interpreted as having a resolution of one digit after the decimal place.

Object Description

Index	2450h
Name	PID Tolerance
Object Type	ARRAY
Data Type	INTEGER16

Entry Description

Sub-Index	0h
Description	Largest sub-index supported
Access	RO
PDO Mapping	No
Value Range	2
Default Value	2

Sub-Index	1h or 2h (x = 1 or 2)
Description	PIDx Tolerance
Access	RW
PDO Mapping	No
Value Range	0 to 100 (0% to 10%)
Default Value	10 [1%]

3.4.46. Object 2451h: PID Integral Gain

This object describes the integral gain (K_i in Figure 15) of the PID algorithm. The value is always interpreted as having a resolution of one digit after the decimal place.

Object Description

Index	2451h
Name	PID Integral Gain
Object Type	ARRAY
Data Type	INTEGER16

Entry Description

Sub-Index	0h
Description	Largest sub-index supported
Access	RO
PDO Mapping	No
Value Range	2
Default Value	2

Sub-Index	1h or 2h (x = 1 or 2)
Description	PIDx Integral Gain
Access	RW
PDO Mapping	No
Value Range	0 to 100
Default Value	10 [1.0]

3.4.47. Object 2452h: PID Derivative Gain

This object describes the derivative gain (Kd in Figure 15) of the PID algorithm. The value is always interpreted as having a resolution of one digit after the decimal place.

Object Description

Index	2452h
Name	PID Derivative Gain
Object Type	ARRAY
Data Type	INTEGER16

Entry Description

Sub-Index	0h
Description	Largest sub-index supported
Access	RO
PDO Mapping	No
Value Range	2
Default Value	2

Sub-Index	1h or 2h (x = 1 or 2)
Description	PIDx Derivative Gain
Access	RW
PDO Mapping	No
Value Range	0 to 100
Default Value	10 [1.0]

3.4.48. Object 2453h: PID Target Source

This object defines the type of input that will be used to determine the target process value for the PID control loop. The available control sources on the 1i2o controller are listed in Table 15. Not all sources would make sense to use as a PID target source, and it is the user's responsibility to select a source that makes sense for the application. A selection of "Control Source Not Used" disables the associated PID control function block.

Object Description

Index	2453h
Name	PID Target Source
Object Type	ARRAY
Data Type	UNSIGNED8

Entry Description

Sub-Index	0h
Description	Largest sub-index supported
Access	RO
PDO Mapping	No
Value Range	2
Default Value	2

Sub-Index	1h or 2h (x = 1 or 2)
Description	PIDx Target Source
Access	RW
PDO Mapping	No
Value Range	See Table 15
Default Value	0 (control not used, PID disabled)

3.4.49. Object 2454h: PID Target Number

This object defines the number of the source that will be used as the target PV for the PID control loop. The available control numbers are dependent on the source selected, as shown in Table 16. Once selected, the control will convert the commanded target into a percentage value using the scaling limits of the control source/number as defined in Table 17.

Object Description

Index	2454h
Name	PID Target Number
Object Type	ARRAY
Data Type	UNSIGNED8

Entry Description

Sub-Index	0h
Description	Largest sub-index supported
Access	RO
PDO Mapping	No
Value Range	2
Default Value	2

Sub-Index	1h or 2h (x = 1 or 2)
Description	PIDx Target Number
Access	RW
PDO Mapping	No
Value Range	See Table 16
Default Value	0 (null source selected)

3.4.50. Object 2455h: PID Feedback Source

This object defines the type of input that will be used to determine the feedback process value for the PID control loop. The available control sources on the 1i2o controller are listed in Table 15. Not all sources would make sense to use as a PID feedback source, and it is the user's responsibility to select a source that makes sense for the application. A selection of "Control Source Not Used" disables the associated PID control function block.

Object Description

Index	2455h
Name	PID Feedback Source
Object Type	ARRAY
Data Type	UNSIGNED8

Entry Description

Sub-Index	0h
Description	Largest sub-index supported
Access	RO
PDO Mapping	No
Value Range	2
Default Value	2

Sub-Index	1h or 2h (x = 1 or 2)
Description	PIDx Feedback Source
Access	RW
PDO Mapping	No
Value Range	See Table 15
Default Value	0 (control not used, PID disabled)

3.4.51. Object 2456h: PID Feedback Number

This object defines the number of the source that will be used as the feedback PV for the PID control loop. The available control numbers are dependent on the source selected, as shown in Table 16. Once selected, the control will convert the measured/received feedback into a percentage value using the scaling limits of the control source/number as defined in Table 17.

Object Description

Index	2456h
Name	PID Feedback Number
Object Type	ARRAY
Data Type	UNSIGNED8

Entry Description

Sub-Index	0h
Description	Largest sub-index supported
Access	RO
PDO Mapping	No
Value Range	2
Default Value	2

Sub-Index	1h or 2h (x = 1 or 2)
Description	PIDx Feedback Number
Access	RW
PDO Mapping	No
Value Range	See Table 16
Default Value	0 (null source selected)

3.4.52. Object 2457h: PID Control Response

This object defines the output profile for the PID control function block in a push-pull dual output system. The options for this object are listed in Table 23.

Object Description

Index	2457h
Name	PID Control Response
Object Type	ARRAY
Data Type	UNSIGNED8

Entry Description

Sub-Index	0h
Description	Largest sub-index supported
Access	RO
PDO Mapping	No
Value Range	2
Default Value	2

Sub-Index	1h or 2h (x = 1 or 2)
Description	PIDx Control Response
Access	RW
PDO Mapping	No
Value Range	See Table 23
Default Value	0 (single output)

3.4.53. Object 2460h: PID Output Field Value

This read-only output contains the PID control function block FV (as a percentage) that can be used as the input source for another function block (i.e. analog output.) It will be a value between 0 to 100% as per the algorithm defined in Figure 15. The physical unit for this object is percentage, and the value is always interpreted as having a resolution of one digit after the decimal place.

Object Description

Index	2460h
Name	PID Output FV
Object Type	ARRAY
Data Type	INTEGER16

Entry Description

Sub-Index	0h
Description	Largest sub-index supported
Access	RO
PDO Mapping	No
Value Range	2
Default Value	2

Sub-Index	1h or 2h (x = 1 or 2)
Description	PIDx Output FV
Access	RO
PDO Mapping	Yes
Value Range	0 to 1000 (0 to 100%)
Default Value	No

3.4.54. Object 2500h: EC Extra Received Process Value

This object provides an extra control source in order to allow other function blocks to be controlled by data received from a CANopen ® RPDO. It functions similarly to any other writeable, mappable PV object, such as 7300h AO Output PV.

Object Description

Index	2500h
Name	EC Extra Received PV
Object Type	ARRAY
Data Type	INTEGER16

Entry Description

Sub-Index	0h
Description	Largest sub-index supported
Access	RO
PDO Mapping	No
Value Range	6
Default Value	6

Sub-Index	1h to 6h (x = 1 to 6)
Description	ECx Received PV
Access	RW
PDO Mapping	Yes
Value Range	Integer16
Default Value	No

3.4.55. Object 2502h: EC Decimal Digits PV

This object describes the number of digits following the decimal point (i.e. resolution) of the extra control data, which is interpreted with data type Integer16 in the process value object.

Object Description

Index	2502h
Name	EC Decimal Digits PV
Object Type	ARRAY
Data Type	UNSIGNED8

Entry Description

Sub-Index	0h
Description	Largest sub-index supported
Access	RO
PDO Mapping	No
Value Range	6
Default Value	6

Sub-Index	1h to 6h (x = 1 to 6)
Description	ECx Decimal Digits PV
Access	RW
PDO Mapping	No
Value Range	0 to 4
Default Value	1 (0.1 resolution)

3.4.56. Object 2520h: EC Scaling 1 PV

This object defines the minimum value of the extra control source. It used as the Scaling 1 value by other functions blocks when the EC has been selected as the source for the X-Axis data, i.e. as seen in Figure 11. There is no physical unit associate with the data, but it uses the same resolution as the received PV as defined in object 2502h, EC Decimal Digits PV. This object must always be smaller than object 2522h EC Scaling 2 PV.

Object Description

Index	2520h
Name	EC Scaling 1 PV
Object Type	ARRAY
Data Type	INTEGER16

Entry Description

Sub-Index	0h
Description	Largest sub-index supported
Access	RO
PDO Mapping	No
Value Range	6
Default Value	6

Sub-Index	1h to 6h (x = 1 to 6)
Description	ECx Scaling 1 PV
Access	RW
PDO Mapping	No
Value Range	-32768 to 2522h sub-index X
Default Value	0

3.4.57. Object 2522h: EC Scaling 2 PV

This object defines the maximum value of the extra control source. It used as the Scaling 2 value by other functions blocks when the EC has been selected as the source for the X-Axis data, i.e. as seen in Figure 11. There is no physical unit associate with the data, but it uses the same resolution as the received PV as defined in object 2502h, EC Decimal Digits PV. This object must always be larger than object 2520h EC Scaling 1 PV.

Object Description

Index	2522h
Name	EC Scaling 2 PV
Object Type	ARRAY
Data Type	INTEGER16

Entry Description

Sub-Index	0h
Description	Largest sub-index supported
Access	RO
PDO Mapping	No
Value Range	6
Default Value	6

Sub-Index	1h to 6h (x = 1 to 6)
Description	ECx Scaling 2 PV
Access	RW
PDO Mapping	No
Value Range	2520h sub-index X to 32767
Default Value	1000 (100.0)

3.4.58. Object 30z0h: LTz Input X-Axis Source

This object defines the type of input that will be used to determine the X-Axis input process value for the lookup table function. The available control sources on the 1i2o controller are listed in Table 15. Not all sources would make sense to use as an X-Axis input, and it is the user's responsibility to select a source that makes sense for the application. A selection of "Control Source Not Used" disables the associated lookup table function block.

Object Description

Index	30z0h (where z = 1 to 6)
Name	LTz Input X-Axis Source
Object Type	VARIABLE
Data Type	UNSIGNED8

Entry Description

Sub-Index	0h
Access	RW
PDO Mapping	No
Value Range	See Table 15
Default Value	0 (control not used, PID disabled)

3.4.59. Object 30z1h: LTz Input X-Axis Number

This object defines the number of the source that will be used as the X-Axis input PV for the lookup table function. The available control numbers are dependent on the source selected, as shown in Table 16. Once selected, the limits for the points on the X-Axis will be constrained by the scaling objects of the control source/number as defined in Table 17.

Object Description

Index	30z1h (where z = 1 to 6)
Name	LTz Input X-Axis Number
Object Type	VARIABLE
Data Type	UNSIGNED8

Entry Description

Sub-Index	0h
Access	RW
PDO Mapping	No
Value Range	See Table 16
Default Value	0 (null control source)

3.4.60. Object 30z2h: LTz X-Axis Decimal Digits PV

This object describes the number of digits following the decimal point (i.e. resolution) of the X-Axis input data and the points in the lookup table. It should be set equal to the decimal digits used by the PV from the control source/number as defined in Table 17.

Object Description

Index	30z2h (where z = 1 to 6)
Name	LTz X-Axis Decimal Digits PV
Object Type	VARIABLE
Data Type	UNSIGNED8

Entry Description

Sub-Index	0h
Access	RW
PDO Mapping	No
Value Range	0 to 4 (see Table 17)
Default Value	0

3.4.61. Object 30z3h: LTz Y-Axis Decimal Digits PV

This object describes the number of digits following the decimal point (i.e. resolution) of the Y-Axis points in the lookup table. When the Y-Axis output is going to be the input to another function block (i.e. an analog output), it is recommended that this value be set equal to the decimal digits used by the block that is using the lookup table as the control source/number.

Object Description

Index	30z3h (where z = 1 to 6)
Name	LTz Y-Axis Decimal Digits PV
Object Type	VARIABLE
Data Type	UNSIGNED8

Entry Description

Sub-Index	0h
Access	RW
PDO Mapping	No
Value Range	0 to 4
Default Value	0

3.4.62. Object 30z4h: LTz Point Response

This object determines the Y-Axis output response to changes in the X-Axis input. The value set in sub-index 1 determines the X-Axis type (i.e. data or time), while all other sub-indexes determine the response (ramp, step, ignore) between two points on the curve. The options for this object are listed in Table 24. See Figure 18 for an example of the difference between a step and ramp response.

Object Description

Index	30z4h (where z = 1 to 6)
Name	LTz Point Response
Object Type	ARRAY
Data Type	UNSIGNED8

Entry Description

Sub-Index	0h
Description	Largest sub-index supported
Access	RO
PDO Mapping	No
Value Range	11
Default Value	11

Sub-Index	1h
Description	X-Axis Type
Access	RW
PDO Mapping	No
Value Range	See Table 24 (0 or 1)
Default Value	0 (x-axis data response)

Sub-Index	2h to 11h (x = 2 to 11)
Description	LTz Point X Response
Access	RW
PDO Mapping	No
Value Range	See Table 24 (0, 1 or 2)
Default Value	1 (ramp to response)

3.4.63. Object 30z5h: LTz Point X-Axis PV

This object defines the X-Axis data for the 11 calibration points on the lookup table, resulting in 10 different output slopes.

When a data response is selected for the X-Axis type (sub-index 1 of object 30z4), this object is constrained such that X1 cannot be less than the Scaling 1 value of the selected control source/number, and X11 cannot be more than the Scaling 2 value. The rest of the points are constrained by the formula below. The physical unit associated with the data will be that of the selected input, and it will use the resolution defined in object 30z2h, LTz X-Axis Decimal Digits PV.

$$\text{MinInputRange} \leq X_1 \leq X_2 \leq X_3 \leq X_4 \leq X_5 \leq X_6 \leq X_7 \leq X_8 \leq X_9 \leq X_{10} \leq X_{11} \leq \text{MaxInputRange}$$

When a time response has been selected, each point on the X-Axis can be set anywhere from 1 to 86,400,000ms.

Object Description

Index	30z5h (where z = 1 to 6)
Name	LTz Point X-Axis PV
Object Type	ARRAY
Data Type	INTEGER32

Entry Description

Sub-Index	0h
Description	Largest sub-index supported
Access	RO
PDO Mapping	No
Value Range	11
Default Value	11

Sub-Index	1h to 11h (x = 1 to 11)
Description	LTz Point X-Axis PVx
Access	RW
PDO Mapping	No
Value Range	See above (data) 1 to 86400000 (time)
Default Value	10*(x-1) No

3.4.64. Object 30z6h: LTz Point Y-Axis PV

This object defines the Y-Axis data for the 11 calibration points on the lookup table, resulting in 10 different output slopes. The data is unconstrained and has no physical unit associate with it. It will use the resolution defined in object 30z3h, LTz Y-Axis Decimal Digits PV.

Object Description

Index	30z6h (where z = 1 to 6)
Name	LTz Point Y-Axis PV
Object Type	ARRAY
Data Type	INTEGER16

Entry Description

Sub-Index	0h
Description	Largest sub-index supported
Access	RO
PDO Mapping	No
Value Range	11
Default Value	11

Sub-Index	1h to 11h (x = 1 to 11)
Description	LTz Point Y-Axis PVx
Access	RW
PDO Mapping	No
Value Range	Integer16
Default Value	10*(x-1) [i.e. 0, 10, 20, 30, ... 100]

3.4.65. Object 30z7h: LTz Output Y-Axis PV

This read-only object contains the lookup table function block PV that can be used as the input source for another function block (i.e. analog output.) The physical unit for this object is undefined, and it will use the resolution defined in object 30z3h, LTz Y-Axis Decimal Digits PV.

Object Description

Index	30z7h (where z = 1 to 6)
Name	LTz Output Y-Axis PV
Object Type	VARIABLE
Data Type	INTEGER16

Entry Description

Sub-Index	0h
Access	RO
PDO Mapping	Yes
Value Range	Integer16
Default Value	No

3.4.66. Object 4000h: Logic Block Enable

This object defines whether or not the logic shown in Figure 22 will be evaluated.

Object Description

Index	4000h
Name	Logic Block Enable
Object Type	ARRAY
Data Type	BOOLEAN

Entry Description

Sub-Index	0h
Description	Largest sub-index supported
Access	RO
PDO Mapping	No
Value Range	4
Default Value	4

Sub-Index	1h to 4h (x = 1 to 4)
Description	LBx Enable
Access	RW
PDO Mapping	No
Value Range	0 (FALSE) or 1 (TRUE)
Default Value	0 [FALSE]

3.4.67. Object 4010h: Logic Block Selected Table

This read-only object reflects what table has been selected as the output source for the logic block after the evaluation shown in Figure 22 has been performed.

Object Description

Index	4010h
Name	Logic Block Selected Table
Object Type	ARRAY
Data Type	UNSIGNED8

Entry Description

Sub-Index	0h
Description	Largest sub-index supported
Access	RO
PDO Mapping	No
Value Range	4
Default Value	4

Sub-Index	1h to 4h (x = 1 to 4)
Description	LBx Selected Table
Access	RO
PDO Mapping	Yes
Value Range	1 to 6
Default Value	No

3.4.68. Object 4020h: Logic Block Output PV

This read-only object reflects the output from the selected table, interpreted as a percentage. The limits for the percentage conversion are based on the range of the lookup tables Y-Axis Output PV as shown in Table 17.

Object Description

Index	4020h
Name	Logic Block Output PV
Object Type	ARRAY
Data Type	UNSIGNED8

Entry Description

Sub-Index	0h
Description	Largest sub-index supported
Access	RO
PDO Mapping	No
Value Range	4
Default Value	4

Sub-Index	1h to 4h (x = 1 to 4)
Description	LBx Output PV
Access	RO
PDO Mapping	Yes
Value Range	Dependent on Selected Table
Default Value	No

3.4.69. Object 4x01h: LBx Lookup Table Numbers

This object determines which of the six lookup tables supports on the 1i2o are associated with a particular function within the given logic block. Up to three tables can be linked to each logic function.

Object Description

Index	4x01h (where x = 1 to 4)
Name	LBx Lookup Table Numbers
Object Type	ARRAY
Data Type	UNSIGNED8

Entry Description

Sub-Index	0h
Description	Largest sub-index supported
Access	RO
PDO Mapping	No
Value Range	3
Default Value	3

Sub-Index	1h to 3h (y = A to C)
Description	LBx Lookup Table Y Number
Access	RW
PDO Mapping	No
Value Range	1 to 6
Default Value	See Table 30

3.4.70. Object 4x02h: LBx Function Logical Operator

This object determines how the results of the three conditions for each function are to be compared to one another to determine the overall state of the function output. There are up to three functions that can be evaluated in each logic block. The options for this object are defined in Table 28. See Section 1.8 for more information about how this object is used.

Object Description

Index	4x02h (where x = 1 to 4)
Name	LBx Function Logical Operator
Object Type	ARRAY
Data Type	UNSIGNED8

Entry Description

Sub-Index	0h
Description	Largest sub-index supported
Access	RO
PDO Mapping	No
Value Range	3
Default Value	3

Sub-Index	1h to 3h (y = A to C)
Description	LBx Function Y Logical Operator
Access	RW
PDO Mapping	No
Value Range	See Table 28
Default Value	Function A = 1 (and all) Function B = 1 (and all) Function C = 0 (default)

- 3.4.71. Object 4x11h: LBx Function A Condition 1
- 3.4.72. Object 4x12h: LBx Function A Condition 2
- 3.4.73. Object 4x13h: LBx Function A Condition 3
- 3.4.74. Object 4x21h: LBx Function B Condition 1
- 3.4.75. Object 4x22h: LBx Function B Condition 2
- 3.4.76. Object 4x23h: LBx Function B Condition 3
- 3.4.77. Object 4x31h: LBx Function C Condition 1
- 3.4.78. Object 4x32h: LBx Function C Condition 2
- 3.4.79. Object 4x33h: LBx Function C Condition 3

These objects, 4xyzh, represent Logic Block z, Function y, Condition z, where x = 1 to 4, y = A to C, and z = 1 to 3. All of these objects are a special type of record, defined in Table 25. Information on how to use these objects is defined in Section 1.8.

Object Description

Index	4xyzh
Name	LBx Function y Condition z
Object Type	RECORD
Data Type	UNSIGNED8

Entry Description

Sub-Index	0h
Description	Largest sub-index supported
Access	RO
PDO Mapping	No
Value Range	5
Default Value	5

Sub-Index	1h
Description	Argument 1 Source
Access	RW
PDO Mapping	No
Value Range	See Table 15
Default Value	1 (CANopen Message)

Sub-Index	2h
Description	Argument 1 Number
Access	RW
PDO Mapping	No
Value Range	See Table 16
Default Value	3 (EC Received PV 1)

Sub-Index	3h
Description	Argument 2 Source
Access	RW
PDO Mapping	No
Value Range	See Table 15
Default Value	3 (Constant PV)

Sub-Index	4h
Description	Argument 2 Number
Access	RW
PDO Mapping	No
Value Range	See Table 16
Default Value	3 (Constant FV 3)

Sub-Index	5h
Description	Operator
Access	RW
PDO Mapping	No
Value Range	See Table 26
Default Value	0 (Equals)

3.4.80. Object 5010h: Constant Field Value

This object is provided to allow the user to compare against a fixed value, i.e. for setpoint control in a PID loop, or in a conditional evaluation for a logic block. The first two values in this object are fixed at FALSE (0) and TRUE (1). There are four other sub-indexes provide for other unconstrained data.

Object Description

Index	5010h
Name	Constant Field Value
Object Type	ARRAY
Data Type	FLOAT32

Entry Description

Sub-Index	0h
Description	Largest sub-index supported
Access	RO
PDO Mapping	No
Value Range	6
Default Value	6

Sub-Index	1h
Description	Constant False
Access	RO
PDO Mapping	No
Value Range	0
Default Value	0 (false)

Sub-Index	2h
Description	Constant True
Access	RO
PDO Mapping	No
Value Range	1
Default Value	1 (true)

Sub-Index	3h
Description	Constant FV 3
Access	RW
PDO Mapping	No
Value Range	Float32
Default Value	25.0

Sub-Index	4h
Description	Constant FV 4
Access	RW
PDO Mapping	No
Value Range	Float32
Default Value	50.0

Sub-Index	5h
Description	Constant FV 5
Access	RW
PDO Mapping	No
Value Range	Float32
Default Value	75.0

Sub-Index	6h
Description	Constant FV 6
Access	RW
PDO Mapping	No
Value Range	Float32
Default Value	100.0

Object 5020h: Power Supply Field Value

This read-only object is available for diagnostic feedback purposes. It reflects the measured voltage powering the controller. The physical unit for this object is volts.

Object Description

Index	5020h
Name	Power Supply Field Value
Object Type	VARIABLE
Data Type	FLOAT32

Entry Description

Sub-Index	0h
Access	RO
PDO Mapping	Yes
Value Range	0 to 70 [V]
Default Value	No

3.4.81. Object 5030h: Processor Temperature Field Value

This read-only object is available for diagnostic feedback purposes. It reflects the measured temperature of the processor, which will always run approximately 10°C to 20°C above ambient. The physical unit for this object is degrees Celsius.

Object Description

Index	5030h
Name	Processor Temperature Field Value
Object Type	VARIABLE
Data Type	FLOAT32

Entry Description

Sub-Index	0h
Access	RO
PDO Mapping	Yes
Value Range	-50 to 150 [°C]
Default Value	No

3.4.82. Object 5555h: Start in Operational Mode

This object allows the unit to start in Operational mode without requiring the presence of a CANopen ® Master on the network. It is intended to be used only when running the 1i2o controller as a stand-alone module. This should always be set FALSE whenever it is connected to a standard master/slave network.

Object Description

Index	5555h
Name	Start in Operational Mode
Object Type	VARIABLE
Data Type	BOOLEAN

Entry Description

Sub-Index	0h
Access	RW
PDO Mapping	No
Value Range	0 (FALSE) or 1 (TRUE)
Default Value	0 [FALSE]

APPENDIX A – Technical Specifications

Power Supply

Power Supply Input	12, 24 VDC nominal (8...36VDC power supply range)
Supply Current	41 mA at 12 V Typical, 29 mA at 24 V Typical, 21 mA at 48 V Typical
Protection	Reverse polarity protection is provided. Power supply input section protects against transient surges and shorts. Overvoltage protection up to 38V is provided. Overvoltage (undervoltage) shutdown of the output load is provided.

Inputs

Analog Input Functions	Voltage [V], Current [mA], Resistive [kΩ], PWM [%], Frequency [Hz], RPM
Voltage Input	0-1V (Impedance 1 MΩ) 0-2.5V (Impedance 1 MΩ) 0-5V (Impedance 200 KΩ) 0-10V (Impedance 133 KΩ)
Current Input	0-20mA (Impedance 124 Ω) 4-20mA (Impedance 124 Ω)
Resistive Input	25 Ω to 250 kΩ
PWM Input	0 to 100% (at 10 Hz to 1kHz or 100 Hz to 10 kHz) Selectable 10kΩ pullup to +5V or pulldown to AGND resistor
Frequency Input	0.5 Hz to 50 Hz, 10 Hz to 1 kHz, or 100 Hz to 10 kHz Selectable 10kΩ pullup to +5V or pulldown to AGND resistor
Digital Input Function	5V CMOS, Active High or Active Low Selectable 10kΩ pullup to +5V or pulldown to AGND resistor Normal, Inverse or Latched (push-button) response
Input Accuracy	<1% full scale error (all types)
Input Resolution	12-bit
Error Detection/Reaction	Out of Range High and Low detection EMCY code generation (object 1003h) and fault reaction possible (1029h) Output(s) shutdown function can be enabled.

Outputs

Analog Output Functions	Current [mA], Voltage [V], PWM [%], Digital On/Off, Hotshot On/Off
Output Type	High side switch (sourcing output), Grounded Load Current sensing for close-loop control, current feedback on object 2370h
Current PID Loop	Factory calibrated. User configurable (use with caution)
Protection for Output+	Fully protected against short circuit to ground and short circuit to power supply rail. Unit will fail safe in the case of a short circuit condition, self-recovering when the short is removed
Error Detection/Reaction	EMCY code generation (object 1003h) and fault reaction possible (1029h) when an open or short circuit is detected at the output (current mode only)
Output Accuracy	Output Accuracy Output Current mode <2% full scale error Output Voltage mode <3% full scale error Output PWM Duty Cycle mode < 3% full scale error
Independence	Outputs are fully independent from one another with two exceptions: a) both use the same AO Dither Frequency (object 2320h sub-index 1) b) both use the same AO Output Frequency (object 2380h sub-index 1)
Voltage Reference	Voltage Reference +5V, 10 mA, 0.5% Short circuit protected (current limited to 22-24 mA) Protected from connection to the power supply rail.

Communication

CAN	1 CAN 2.0B port, protocol CiA CANopen ® By default, the 1i2o Controller transmits measured input (FV object 7100h) and output current feedback (FV object 2370h) on TPDO1
Network Termination	According to the CAN standard, it is necessary to terminate the network with external termination resistors. The resistors are 120 Ohm, 0.25W minimum, metal film or similar type. They should be placed between CAN_H and CAN_L terminals at both ends of the network.

General Specifications

Microprocessor	32-bit, 128 KByte flash program memory
Control Logic	User programmable functionality using SDO object access, per CiA DS-301
User Interface	.EDS provided to interface to standard CANopen ® tools
Operating Conditions	-40 to 85 °C (-40 to 185 °F)
Storage	-50 to 105 °C (-58 to 221 °F)
Packaging	Encapsulated in a rugged aluminum housing Refer to the dimensional drawing in <i>Installation Instructions</i> . Watertight Deutsch IPD connectors Can be mounted directly on the valve block or remotely Suitable for moist, high shock, vibrating and non-hazardous environments
EMC Compliance	CE marking
Protection	IP67; Unit is conformal coated within housing.
Weight	0.70 lb., 0.32kg



OUR PRODUCTS

Actuator Controls
Battery Chargers
CAN bus Controls, Gateways
CAN/Wifi, CAN/Bluetooth
Current Converters
DC/DC Power Converters
DC Voltage/Current Signal Converters
Engine Temperature Scanners
Ethernet/CAN Converters
Fan Drive Controllers
Hydraulic Valve Controllers
I/O Controls
LVDT Simulators
Machine Control Systems
Motor Controls
PID Controls
Position Sensors, Angle Measurement Inclinometers
Power Supplies
PWM Signal Converters/Isolators
Resolver Signal Conditioners
Service Tools
Signal Conditioners
Strain Gauge CAN Controls
Surge Suppressors

OUR COMPANY

Axiomatic provides electronic machine controls, components, and systems to the off-highway, commercial vehicle, electric vehicle, power generator set, material handling, renewable energy and industrial OEM markets.

We provide efficient, innovative solutions that focus on adding value for our customers.

We emphasize service and partnership with our customers, suppliers, and employees to build long term relationships and mutual trust.

QUALITY DESIGN AND MANUFACTURING

Axiomatic is an ISO 9001:2008 registered facility.

SERVICE

All products to be returned to Axiomatic require a Return Materials Authorization Number (RMA#).

Please provide the following information when requesting an RMA number:

- Serial number, part number
- Axiomatic invoice number and date
- Hours of operation, description of problem
- Wiring set up diagram, application
- Other comments as needed

When preparing the return shipping paperwork, please note the following. The commercial invoice for customs (and packing slip) should state the harmonized international HS (tariff code), valuation and return goods terminology, as shown in italics below. The value of the units on the commercial invoice should be identical to their purchase price.

*Goods Made In Canada (or Finland)
Returned Goods for Warranty Evaluation, HS: 9813.00
Valuation Identical Goods
Axiomatic RMA#*

WARRANTY, APPLICATION APPROVALS/LIMITATIONS

Axiomatic Technologies Corporation reserves the right to make corrections, modifications, enhancements, improvements, and other changes to its products and services at any time and to discontinue any product or service without notice. Customers should obtain the latest relevant information before placing orders and should verify that such information is current and complete. Users should satisfy themselves that the product is suitable for use in the intended application. All our products carry a limited warranty against defects in material and workmanship. Please refer to our Warranty, Application Approvals/Limitations and Return Materials Process as described on www.axiomatic.com/service.html.

CONTACTS

Axiomatic Technologies Corporation
5915 Wallace Street
Mississauga, ON
CANADA L4Z 1Z8
TEL: +1 905 602 9270
FAX: +1 905 602 9279
www.axiomatic.com

Axiomatic Technologies Oy
Höytämöntie 6
33880 Lempäälä
FINLAND
TEL: +358 3 3595 600
FAX: +358 3 3595 660
www.axiomatic.fi