

12 Input, 8 Signal Output & 1 Relay Output Controller with CAN, SAEJ1939

USER MANUAL

P/N: AX030210

P/N: AX030210-01 – J1939 500kbits/s Baud Rate

P/N: AX030210-02 – Custom J1939 Baud Rate, 1Mbits/s

VERSION HISTORY

| Version | Date | Author | Modification |
|----------------|----------------|----------------|----------------------------------------------------------------|
| 1.0.0. | Nov 15, 2018 | Antti Keränen | Initial Version |
| 1.0.0 | Nov. 16, 2018 | Amanda Wilkins | Added Technical Spec. Updated name of User manual to one name. |
| --- | April 20, 2020 | Amanda Wilkins | Added vibration, Marine TAC approvals, EMC compliance |
| 1.0.1 | Dec. 10, 2020 | Antti Keränen | Added a note about Frequency/PWM input type limitations. |

ACRONYMS

| | |
|----------|----------------------------------------------------------------|
| ACK | Positive Acknowledgement (from SAE J1939 standard) |
| BATT +/- | Battery positive (a.k.a. Vps) or Battery Negative (a.k.a. GND) |
| ECU | Electronic Control Unit (from SAE J1939 standard) |
| GND | Ground reference (a.k.a. BATT-) |

LIST OF CONTENTS

| | |
|------------------------------------------------------------------|-----------|
| 1. OVERVIEW OF THE CONTROLLER | 9 |
| 2. CONTROLLER FUNCTION BLOCKS | 11 |
| 2.1. Input Function Blocks | 11 |
| 2.1.1. Resistive Input | 14 |
| 2.1.2. Digital Input..... | 14 |
| 2.1.3. Input Filtering | 14 |
| 2.2. Output Function Blocks..... | 15 |
| 2.2.1. Relay Output..... | 15 |
| 2.2.2. Reference Voltages | 15 |
| 2.3. PID Controller Block | 15 |
| 2.4. Lookup Tables | 17 |
| 2.5. Programmable Logic..... | 18 |
| 2.6. Math Function Block | 19 |
| 2.7. Variable Data | 20 |
| 2.8. Diagnostics Blocks..... | 20 |
| 2.9. CAN Transmit Function Block | 24 |
| 2.9.1. CAN Transmit Message Setpoints | 24 |
| 2.9.2. CAN Transmit Signal Setpoints | 24 |
| 2.10. CAN Receive Function Block | 25 |
| 2.11. DTC React | 25 |
| 2.12. Available Control Sources | 26 |
| 3. INSTALLATION INSTRUCTIONS | 29 |
| 3.1. Dimensions and Pinout..... | 29 |
| 4. OVERVIEW OF THE J1939 FEATURES | 30 |
| 4.1. Introduction to Supported Messages..... | 30 |
| 4.2. NAME, Address and Software ID | 31 |
| 5. ECU SETPOINTS ACCESSED WITH ELECTRONIC ASSISTANT | 33 |
| 5.1. Accessing the ECU Using EA..... | 33 |
| 5.2. J1939 Network Parameters | 34 |
| 5.3. Universal Input Setpoints..... | 35 |
| 5.4. Resistive Input Setpoints | 36 |
| 5.5. Digital Input Setpoints..... | 37 |
| 5.6. Signal Output Setpoints | 38 |
| 5.7. Relay Output Setpoints..... | 39 |
| 5.8. Reference Voltage Setpoints | 40 |
| 5.9. Constant Data List Setpoints | 41 |
| 5.10. Variable Data List Setpoints | 42 |
| 5.11. PID Control | 43 |
| 5.12. Lookup Table | 44 |

| | | |
|-----------|---------------------------------------------------------------------------------------------------------------------------------------------|-----------|
| 5.13. | Programmable Logic..... | 46 |
| 5.14. | Math Function Block | 48 |
| 5.15. | CAN Transmit Setpoints | 50 |
| 5.16. | CAN Receive Setpoints | 52 |
| 5.17. | DTC React | 53 |
| 5.18. | General Diagnostics Options..... | 54 |
| 5.19. | Diagnostics Blocks..... | 55 |
| 6. | REFLASHING OVER CAN WITH EA BOOTLOADER..... | 58 |
| | 300 mA at 12 Vdc Typical..... | A-1 |
| | 155 mA at 24 Vdc Typical..... | A-1 |
| | Inrush does not exceed 500 mA..... | A-1 |
| | Reverse polarity protection is provided. | A-1 |
| | Power supply input section protects against transients, surges (per IEC 60533, Table 4) and short circuits and is isolated from inputs..... | A-1 |
| | All inputs are protected against short circuits to GND or +Vcc. | A-2 |
| | One resistive type input | A-2 |
| | 2 +5V references (sourcing up to 100 mA) +/- 0.1%..... | A-2 |
| | or 2 +10V references (sourcing up to 100 mA) +/-0.2%..... | A-2 |
| | 1 mSec..... | A-2 |
| | One Digital Input..... | A-2 |
| | 0-5V: +/- 1%..... | A-2 |
| | 0-5V or 0-10V: 1 mV | A-2 |
| | Individual short circuit protection is provided..... | A-3 |
| | Each output is protected against shorts to GND or +Vcc..... | A-3 |
| | Fully protected (all physical pins, all inputs, outputs and power) | A-3 |

LIST OF TABLES

| | |
|-------------------------------------------------------------------|----|
| Table 1 – Universal Input Sensor Type Options..... | 11 |
| Table 2 – Debounce Time Options..... | 11 |
| Table 3 - Software Debounce Filter Times..... | 12 |
| Table 4 – Pullup/Pulldown Resistor Options | 12 |
| Table 5 – Active High/Low Options | 13 |
| Table 6 – Digital Input Sensor Type versus Input State..... | 13 |
| Table 7 – Pulse Counter Sensor Type versus Input State | 13 |
| Table 8 – Filter Type Options | 14 |
| Table 9 – Available Output Types for Signal Output..... | 15 |
| Table 10 – PID Response Options..... | 16 |
| Table 11 – X-Axis Type Options..... | 17 |
| Table 12 – PointN – Response Options | 17 |
| Table 13 – Table X – Condition Y, Operator Options..... | 18 |
| Table 14 – Table X – Conditions Logical Operator Options..... | 19 |
| Table 15 – Math function X Operator Options..... | 20 |
| Table 16 – Lamp Set by Event in DM1 Options | 23 |
| Table 17 – FMI for Event Options..... | 23 |
| Table 18 – Low Fault FMIs and corresponding High Fault FMIs | 24 |
| Table 19 – Available Control Sources and Numbers | 27 |
| Table 20 – AX030210 Connector Pinouts | 29 |
| Table 21 – J1939 Network Setpoints | 34 |
| Table 22 – Universal Input Setpoints..... | 35 |
| Table 23 – Resistive Input Setpoints..... | 36 |
| Table 24 – Digital Input Setpoints..... | 37 |
| Table 25 – Signal Output Setpoints..... | 38 |
| Table 26 – Relay Output Setpoints..... | 39 |
| Table 27 – Reference Voltage Setpoints..... | 40 |
| Table 28 – Variable Data Setpoints..... | 42 |
| Table 29 – PID Control Setpoints..... | 43 |
| Table 30 – Lookup Table Setpoints..... | 45 |
| Table 31 – Programmable Logic Setpoints | 47 |
| Table 32 – Math Function Setpoints..... | 49 |
| Table 33 – CAN Transmit Message Setpoints | 51 |
| Table 34 – CAN Receive Setpoints..... | 52 |
| Table 35 – DTC React Setpoints..... | 53 |
| Table 36 – General Diagnostics Options Setpoints..... | 54 |
| Table 37 – Diagnostic Block Setpoints..... | 57 |

LIST OF FIGURES

| | |
|---------------------------------------------------------------------------|----|
| Figure 1 – AX030210 Block Diagram | 9 |
| Figure 2 – Double Minimum and Maximum Error Thresholds..... | 22 |
| Figure 3 – Analog source to Digital input | 28 |
| Figure 4 – AX030210 Dimensional Drawing | 29 |
| Figure 5 – Screen Capture of J1939 Setpoints | 34 |
| Figure 6 – Screen Capture of Universal Input Setpoints | 35 |
| Figure 7 – Screen Capture of Resistive Input Setpoints | 36 |
| Figure 8 – Screen Capture of Digital Input Setpoints | 37 |
| Figure 9 – Screen Capture of Signal / Output Setpoints | 38 |
| Figure 10 – Screen Capture of Relay Output Setpoints | 39 |
| Figure 11 – Screen Capture of Reference Voltage Setpoints | 40 |
| Figure 12 - Screen Capture of Constant Data List Setpoints | 41 |
| Figure 13 – Screen Capture of Variable Data List Setpoints | 42 |
| Figure 14 – Screen Capture of PID Control Setpoints | 43 |
| Figure 15 – Screen Capture of Lookup table Setpoints | 44 |
| Figure 16 – Screen Capture of Programmable Logic Setpoints..... | 46 |
| Figure 17 – Screen Capture of Math Function Block Setpoints | 48 |
| Figure 18 – Screen Capture of CAN Transmit Message Setpoints..... | 50 |
| Figure 19 – Screen Capture of CAN Receive Message Setpoints..... | 52 |
| Figure 20 – Screen Capture of DTC React Setpoints | 53 |
| Figure 21 – Screen Capture of General Diagnostics Options Setpoints | 54 |
| Figure 22 – Screen Capture of Diagnostic Block Setpoints | 55 |

REFERENCES

TDAX030210 Technical Datasheet, 12 Inputs, 8 Signal Outputs & 1 Relay Output Controller
with CAN, Axiomatic Technologies 2018

This document assumes the reader is familiar with the SAE J1939 standard. Terminology from the standard is used, but not described in this document.



NOTE: This product is supported by Electronic Assistant® V5.13.98.0 and higher

1. Overview of The Controller

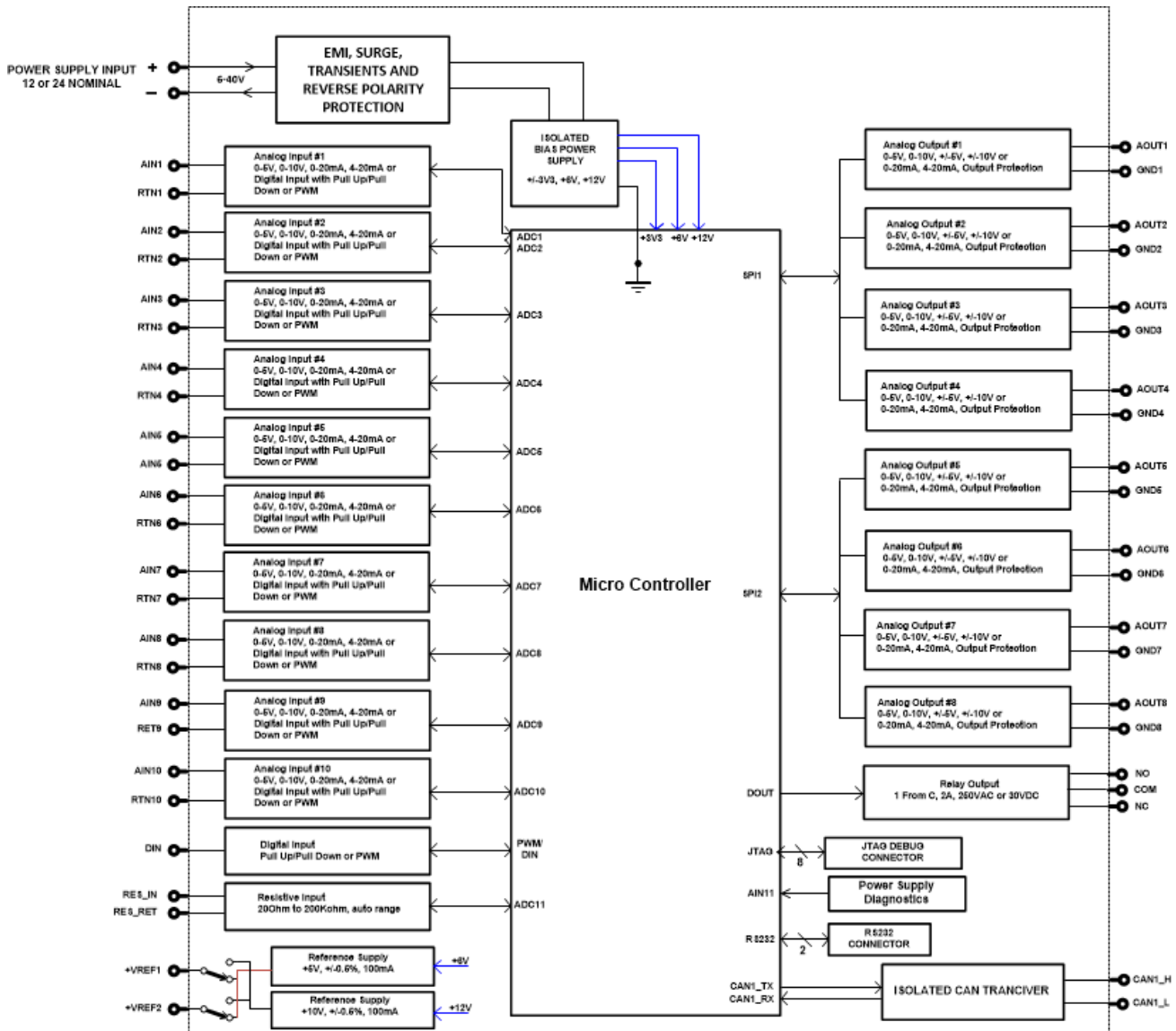

Figure 1 – AX030210 Block Diagram

The 12 Input, 8 Signal Outputs & 1 Relay Output Controller (later 12IN-8SOUT) is designed for extremely versatile control of up to eight signal outputs for generating control signals and one relay output to drive other loads. Its flexible circuit design gives the user a wide range of configurable input and output types. The sophisticated control algorithms allow the user to program the controller for a wide range of applications without the need for custom software.

The controller has ten Universal inputs that can be configured to measure analog voltage or current, frequency/PMW or digital signal, one resistive input capable of measuring resistances from 25Ω to 250kΩ and one Digital input that can be configured to measure digital signals. Measured input data can be sent to a SAE J1939 CAN Network or used to drive outputs directly or through the configurable control algorithms.

Signal outputs can be configured to generate voltage and current signals. Any of the eight signal outputs can be configured to use any of the on-board inputs as either a control signal or an enable signal as well as SAE J1939 CAN Network data.

Settings are user configurable to suit many applications. Configuration is via a *Windows*-based Electronic Assistant® configuration tool and an USB-CAN converter.

Setpoint configuration can be saved in a file which can be used to easily program the same configuration into another AX030210 12In-8SOut Controller. Throughout this document EA setpoint names are referred with bolded text in double-quotes and the setpoint option is referred with italicized text in single-quotes. For example, “**Input Sensor Type**” setpoint set to option ‘*Voltage 0 to 5V*’.

In this document, the configurable properties of the ECU are divided into function blocks, namely Input Function Block, Output Function Block, Diagnostic Function Block, PID Control Function Block, Lookup Table Function Block, Programmable Logic Function Block, Math Function Block, DTC React Function Block, CAN Transmit Message Function Block and CAN Receive Message Function Block. These function blocks are presented in detail in next subchapters.

The 12IN-8SOUT Controller can be ordered using the following part numbers depending on the application.

| | |
|-------------|-----------------------------------------------------------|
| AX030210 | Controller with the default J1939 baud rate (250kbits/s). |
| AX030210-01 | Controller with the 500kbits/s J1939 baud rate. |
| AX030210-02 | Controller with a custom 1Mbits/s J1939 baud rate. |

2. Controller Function Blocks

2.1. Input Function Blocks

The controller has altogether twelve inputs. The ten Universal Inputs can be configured to measure voltage, current, frequency, pulse width (PWM) or digital signals. The Resistive input can measure resistances in range 25Ω ... 250kΩ. The Digital Input can be configured to measure digital signals.

Universal and Digital Input setpoint groups have the “**Input Sensor Type**” setpoint, which is used to configure input type. Selecting input type effects on other setpoints and how they are interpreted and should thus be selected first on this block. The input sensor types for Universal Inputs are listed in Table 1. Digital inputs do not have analog and frequency (12-51) sensor type options in “**Input Sensor Type**” options.

| | |
|----|---------------------------------------|
| 0 | <i>Disabled</i> |
| 12 | <i>Voltage 0 to 5 V</i> |
| 13 | <i>Voltage 0 to 10 V</i> |
| 20 | <i>Current 0 to 20 mA</i> |
| 21 | <i>Current 4 to 20 mA</i> |
| 40 | <i>Frequency 0.5 to 50 Hz</i> |
| 41 | <i>Frequency 10 Hz to 1 kHz</i> |
| 42 | <i>Frequency 100 Hz to 10 kHz</i> |
| 50 | <i>PWM Low Frequency (<1kHz)</i> |
| 51 | <i>PWM High Frequency (>100Hz)</i> |
| 60 | <i>Digital (normal)</i> |
| 61 | <i>Digital (inverse)</i> |
| 62 | <i>Digital (latched)</i> |
| 70 | <i>Pulse Timer</i> |
| 72 | <i>Pulse Counter</i> |
| 73 | <i>Pulse Counter (both edges)</i> |

Table 1 – Universal Input Sensor Type Options

On Universal Inputs analog voltage (i.e. 0-5V, 0-10V) or current (0-20mA, 4-20mA) signals go directly to a 12-bit analog-to-digital converter (ADC) on the processor. The voltage input is a high impedance input protected against shorts to GND or Vcc. In current mode, a 250Ω resistor is used to measure the input signal. Analog signals should be connected to the GND reference pins provided on the connector, per Table 20.

| | |
|---|----------------|
| 0 | <i>None</i> |
| 1 | <i>111ns</i> |
| 2 | <i>1.78us</i> |
| 3 | <i>14.22us</i> |

Table 2 – Debounce Time Options

An additional software debounce filter can be used with Frequency and Digital Input types for filtering the inputs using longer time constants than with the default debounce filter. The available software implemented debounce times are listed in Table 3.

| | |
|---|--------|
| 0 | 0ms |
| 1 | 10ms |
| 2 | 20ms |
| 3 | 40ms |
| 4 | 100ms |
| 5 | 200ms |
| 6 | 400ms |
| 7 | 1000ms |

Table 3 - Software Debounce Filter Times

Frequency/RPM or Pulse Width Modulated (PWM) “**Input Sensor Type**” options connect an input to 16-bit timer pin on the processor. “**Debounce Time**” setpoint is used to select an input capture filter for the timer pin in question. “**Pulse Per Revolution**” setpoint is only associated with the frequency and analog input types. If the setpoint is set to *True*, then the input data will be reported as in rotations-per-minute (RPM). Otherwise, frequency inputs are measured in Hertz.



NOTE: The input channels 3, 6, 7 and 8 have limited accuracy when used for detecting edges (Frequency / PWM measurements). The measurement accuracy can be enhanced using software filtering, but in case the Frequency or PWM duty cycle measurements need to have high accuracy, please avoid using these four channels.



NOTE: The input channels 3 & 8 and 6 & 7 share the timer peripheral used for Frequency / PWM measurements. This limits the Frequency and PWM measurement configuration options available for these inputs. Both inputs of the pair need to be configured to use the same frequency detection range.

The 10 Universal and one Digital Input have all available three Digital “**Input Sensor Type**” options: Normal, Inverse and Latched. With digital input sensor types, the input measurement is given, either 1 (ON) or 0 (OFF). The two Digital Inputs measure digital voltage with 1V threshold, whereas Universal inputs measure digital voltage with 3V threshold.

On Frequency, PWM and digital input modes 10kΩ pull-up or pull-down resistors can be enabled or disabled by setting the value of the “**Pullup/Pulldown Resistor**” setpoint. Setpoint options are given in Table 4. By default, pull-down resistors are enabled for all inputs.

| | |
|---|-----------------|
| 0 | Pullup/down Off |
| 1 | 22 kΩ Pullup |
| 2 | 22 kΩ Pulldown |

Table 4 – Pullup/Pulldown Resistor Options

“**Active High/Active Low**” setpoint is used to configure how signal high and low are interpreted. Setpoint options are given in Table 5. By default, all inputs are selected to be Active High, which means that signal high is interpreted as 1(ON) and signal low as 0(OFF).

| | |
|---|-------------|
| 0 | Active High |
| 1 | Active Low |

Table 5 – Active High/Low Options

Table 6 shows the effect of different digital input types on input signal measurement interpretation with recommended “**Pullup/Pulldown Resistor**” and “**Active High/Low**” combinations. Fault diagnostics are not available for digital input types.

| Input Sensor Type | | Pulldown Active High | Pullup Active Low | Input measured (state) |
|-------------------|--------------------------|-------------------------|----------------------|------------------------|
| 6 | <i>Digital (normal)</i> | High | Low or Open | 1 (ON) |
| | | Low or Open | High | 0 (OFF) |
| 61 | <i>Digital (inverse)</i> | High or Open | Low | 1 (ON) |
| | | Low | High or Open | 0 (OFF) |
| 62 | <i>Digital (latched)</i> | High to Low | Low to High | 0 (no change) |
| | | Low to High | High to Low | 1 (state change) |

Table 6 – Digital Input Sensor Type versus Input State

| Input Sensor Type | | Function |
|-------------------|-----------------------------------|-------------------------------------------------------------------------------------------------------------------------------------------------|
| 70 | <i>Counter</i> | Count pulses in the specified time window (defined using Measuring Window setpoint) |
| 71 | <i>Pulse Counter</i> | Count pulses (only rising edges). Maximum number before wrapping back to zero can be defined using Max Pulse Count setpoint. |
| 72 | <i>Pulse Counter (both edges)</i> | Count pulses (both rising and falling edges). Maximum number before wrapping back to zero can be defined using Max Pulse Count setpoint. |

Table 7 – Pulse Counter Sensor Type versus Input State

Table 7 describes the Pulse Counter Input types available. The main difference between the ‘*Counter*’ and ‘*Pulse Counter*’ types is that ‘*Counter*’ measures the time (defined using “**Measuring Window**”) which is needed to count the specified number of pulses. The ‘*Pulse Counter*’ modes count pulses (using edge detection), independent of time (max count is defined using “**Max Pulse Count**”).

The “**Minimum Range**” and “**Maximum Range**” setpoints are used to define range of the signal input outputs as a control source. For example, if “**Maximum Range**” is set to 4V for an input, the control signal is saturated at 4V if input signal rises above 4V. The “**Minimum Range**” and “**Maximum Range**” setpoints are interpreted in input types units, thus they should be re-adjusted after editing “**Input Sensor Type**”.

Software filters can be applied to the measured input signal. Setpoints “**Software Filter Type**” and “**Software Filter Constant**” are used to configure the software filter. By default, no filter is applied to the signal. Software filtering is described in detail in section 0

The rest of the setpoints in the Input setpoint group are used to configure input related fault diagnostics and are described in section 2.8

2.1.1. Resistive Input

The controller has one Resistive Input in the 8 pin Deutsch connector that can measure resistances and it can be also configured to measure Digital On/Off states. The Digital On/Off state reading is done using an ADC and comparing the conversion results to built-in thresholds.

The preferred Digital Input voltages to the Resistive Input are 0V (low) and 5V (high).

When configured as a Resistive Input, the controller uses the ADC and internal reference current generator to measure the resistance between the Resistive Input pins.

2.1.2. Digital Input

The Digital Input located also in the 8 pin Deutsch connector is capable of detecting Digital On/Off states.

2.1.3. Input Filtering

Measured input data from universal inputs can be filtered to form desired CAN message data. Input filters are configured with “**Filter Type**” and “**Filter Constant**” setpoints. Filters are configured for each input individually.

| | |
|---|--------------------------|
| 0 | <i>No Filtering</i> |
| 1 | <i>Moving Average</i> |
| 2 | <i>Repeating Average</i> |

Table 8 – Filter Type Options

“**Filter Type**” setpoint defines the type of software filter used. Setpoint options are ‘*No Filtering*’, ‘*Moving Average*’ and ‘*Repeating Average*’. The ‘*No Filtering*’ option applies no filtering to the measured input data. The ‘*Moving Average*’ option applies the transfer function below to the measured input data, where $Value_N$ is the current value of the CAN message data, $Value_{N-1}$ is the previous CAN message data and Filter Constant is the value of the “**Filter Constant setpoint**”.

Equation 1 - Moving Average Transfer Function:

$$Value_N = Value_{N-1} + \frac{(Input - Value_{N-1})}{Filter\ Constant}$$

Equation 2 - Repeating Average Transfer Function:

$$Value = \frac{\sum_0^N Input_N}{N}$$

The ‘*Repeating Average*’ option applies the transfer function above to the measured input data, where N is value of the “**Filter Constant**” setpoint. At every reading of the input value, the value is added to the sum. At every Nth read, the sum is divided by N, and the result is new CAN message data. The sum is set to zero for the next read and summing is started again.

2.2. Output Function Blocks

The controller has eight signal outputs, capable of producing both voltage and current signals. The available voltage modes include both positive and negative voltages.

In addition to output type configuration, user can select control, enable and override sources for each output. Also fault mode functionality can be configured.

In case the “**Fault Detection Enabled**” setpoint is set to *True*, the output will be disabled if any of the other outputs is in fault state. The detected faults are short circuit for voltage output modes and open circuit for current modes.

“**Output Type**” setpoint determines what kind of signal the output produces. “**Output Type**” setpoint options are listed in Table 9.

| | |
|---|-----------|
| 0 | 0...5V |
| 1 | 0...10V |
| 2 | -5...5V |
| 3 | -10...10V |
| 4 | 0...20mA |
| 5 | 4...20mA |

Table 9 – Available Output Types for Signal Output

2.2.1. Relay Output

The controller has one Relay output. The Relay is driven by the CPU. The Normally Closed, Normally Open and COMmon pins of the relay are available in the 8 pin Deutsch connector.

The Relay is capable of handling 5A/250VAC.

2.2.2. Reference Voltages

The controller has two user configurable reference voltage outputs. By default, with No Control Source or the Control Source value set to 0, the Reference Voltage is set to 10V.

When a 5V reference is used, the Control Source and Control Number setpoints for the reference voltage need to have a non-zero value. For example, setting the “**VRef #1 Control Source**” to “7 – Control Constant Data” and “**VRef #1 Control Number**” to “2 – Control Constant Data #2” will configure the reference voltage source #1 as a 5V reference.

2.3. PID Controller Block

The PID Control function block is an independent logic block, but it is normally intended to be associated with proportional output control blocks described earlier. When the “**Control Source**” for an output has been setup as a ‘*PID Function Block*’, the command from the selected PID block drives the physical output on the 12IN-8SOUT Controller.

The “**PID Target Command Source**” and “**PID Target Command Number**” setpoints determine control input and the “**PID Feedback Input Source**” and “**PID Feedback Input Number**” setpoints determine the established the feedback signal to the PID function block. The “**PID Response Profile**” will use the selected inputs as per the options listed in Table 10. When active, the PID algorithm will be called every “**PID Loop Update Rate**” in milliseconds.

| | |
|---|-----------------------------|
| 0 | <i>Single Output</i> |
| 1 | <i>Dual Output</i> |
| 2 | <i>Setpoint Control</i> |
| 3 | <i>On When Over Target</i> |
| 4 | <i>On When Below Target</i> |

Table 10 – PID Response Options

When a ‘*Single Output*’ response is selected, the Target and Feedback inputs do not have to share the same units. In both cases, the signals are converted to a percentage values based on the minimum and maximum values associated with the source function block.

For example, a CAN command could be used to set the target value, in which case it would be converted to a percentage value using “**Receive Data Min**” and “**Receive Data Max**” setpoints in the appropriate ‘*CAN Receive X*’ function block. The closed-loop feedback signal (i.e. a 0-5V input) could be connected to ‘*Universal Input 1*’ and selected as the feedback source. In this case the value of the input would be converted to a percentage based on the “**Minimum Range**” and “**Maximum Range**” setpoints in the input block. The output of the PID function would depend on the difference between the commanded target and the measured feedback as a percentage of each signals range. In this mode, the output of the block would be a value from 0% to 100%.

To have the block output in range -100% to 100%, the ‘*Dual Output*’ response needs to be selected. Other than the output range, the ‘*Dual Output*’ mode is equivalent to the ‘*Single Output*’ mode.

When a ‘*Setpoint Control*’ response is selected, the “**PID Target Command Source**” automatically gets updated to ‘*Control Constant Data*’ and cannot be changed. The value set in the associated constant in the Constant Data List function block becomes the desired target value. In this case, both the target and the feedback values are assumed to be in same units and range. The minimum and maximum values for the feedback automatically become the constraints on the constant target. In this mode, the output of the block would be a value from 0% to 100%.

For example, if the feedback was setup as a 4-20mA input, a “**Constant Value X**” setpoint set to 14.2 would automatically be converted to 63.75%. The PID function would adjust the output as needed to have the measured feedback to maintain that target value.

The last two response options, ‘*On When Over Target*’ and ‘*On When Under Target*’, are designed to allow the user to combine the two proportional outputs as a push-pull drive for a system. Both outputs must be setup to use the same control input (linear response) and feedback signal to get the expected output response. In this mode, the output would be between 0% to 100%.

To allow the output to stabilize, the user can select a non-zero value for “**PID Delta Tolerance**”. If the absolute value of $Error_k$ is less than this value, $Error_k$ in the formula below will be set to zero.

The PID algorithm used is shown below, where **G**, **K_i**, **T_i**, **K_d**, **T_d** and **Loop_Update_Rate** are configurable parameters.

$$PIDOutput_k = P_k + I_k + D_k$$

$$P_k = P_Gain * Error_k$$

$$I_k = I_Gain * ErrorSum_k$$

$$D_k = D_Gain * (Error_k - Error_{k-1})$$

$$Error_k = Target - Feedback$$

$$ErrorSum_k = ErrorSum_{k-1} + Error_k$$

$$P_Gain = G$$

$$I_Gain = Ki * T/Ti \text{ (Note: If } Ti \text{ is zero, } I_Gain = 0)$$

$$D_Gain = Kd * Td/T$$

$$T = Loop_Update_Rate * 0.001$$

Equation 3 - PID Control Algorithm

Each system will have to be turned for the optimum output response. Response times, overshoots and other variables will have to be decided by the customer using an appropriate PID tuning strategy. Axiomatic is not responsible for tuning the control system.

2.4. Lookup Tables

Lookup Tables are used to give output response up to 10 slopes per input. If more than 10 slopes are required, A Programmable Logic Block can be used to combine up to three tables to get 30 slopes as described in Section 2.5.

Lookup tables have two differing modes defined by “**X-Axis Type**” setpoint, given in Table 11. Option ‘0 – Data Response’ is the normal mode where block input signal is selected with the “**X-Axis Source**” and “**X-Axis Number**” setpoints and X values present directly input signal values. With option ‘1 – Time Response’ the input signal is time and X values present time in milliseconds. And selected input signal is used as digital enable.

| | |
|---|----------------------|
| 0 | <i>Data Response</i> |
| 1 | <i>Time Response</i> |

Table 11 – X-Axis Type Options

The slopes are defined with (x, y) points and associated point response. X value presents input signal value and Y value corresponding Lookup Table output value. “PointN – Response” setpoint defines type of the slope from preceding point to the point in question. Response options are given in Table 12. ‘Ramp To’ gives a linearized slope between points, whereas ‘Jump to’ gives a point to point response, where any input value between X_{N-1} and X_N will result Lookup Table output being Y_N. “Point0 – Response” is always ‘Jump To’ and cannot be edited. Choosing ‘Ignored’ response causes associated point and all the following points to be ignored.

| | |
|---|----------------|
| 0 | <i>Ignore</i> |
| 1 | <i>Ramp To</i> |
| 2 | <i>Jump To</i> |

Table 12 – PointN – Response Options

In case Time Response is used, the “**Autocycle**” setpoint can be used for generating a repeating, cyclic output while the selected control source enables the time response output of the lookup table.

The X values are limited by minimum and maximum range of the selected input source if the source is one of the Input Blocks or a Math Function Block. For the fore mentioned sources X-Axis data will be redefined when ranges are changed, therefore inputs should be adjusted before changing X-Axis values. For other sources Xmin and Xmax are 0 and 1000. The X-Axis is constraint to be in rising order, thus value of the next index is greater than or equal to preceding one. Therefore, when adjusting the X-Axis data, it is recommended that X_{10} is changed first, then lower indexes in descending order.

$$Xmin \leq X_0 \leq X_1 \leq X_2 \leq X_3 \leq X_4 \leq X_5 \leq X_6 \leq X_7 \leq X_8 \leq X_9 \leq X_{10} \leq Xmax$$

The Y-Axis has no constraints on the data it presents, thus inverse, decreasing, increasing or other response can be easily established. The Smallest of the Y-Axis values is used as Lookup Table output min and the largest of the Y-Axis values is used as Lookup Table output max (i.e. used as Xmin and Xmax values in linear calculation. Ignored points are not considered for min and max values.

2.5. Programmable Logic

The Programmable Logic Function Block is very powerful tool. A Programmable Logic can be linked to up to three Lookup Tables, any of which would be selected only under given conditions. Thus, output of a Programmable Logic at any given time will be the output of the Lookup Table selected by defined logic. Therefore, up to three different responses to the same input, or three different responses to different inputs, can become the input to another function block.

To enable any one of the Programmable Logic blocks, the **“Programmable Logic Enabled”** setpoint must be set to *‘True’*. By default, all Logic blocks are disabled.

The three associated tables are selected by setting **“Table X – Lookup Table Block Number”** setpoint to desired Lookup Table number, for example selecting *1* would set Lookup Table 1 as TableX.

For each TableX there are three conditions that define the logic to select the associated Lookup Table as Logic output. Each condition implements function *Argument1 Operator Argument2* where Operator is logical operator defined by setpoint **“Table X – Condition Y, Operator”**. Setpoint options are listed in Table 13. Condition arguments are selected with **“Table x – Condition Y, Argument Z Source”** and **“Table x – Condition Y, Argument Z Number”** setpoints. If *‘0 – Control not Used’* option is selected as **“Table x – Condition Y, Argument Z Source”** the argument is interpreted as 0.

| | |
|---|-------------------------------------|
| 0 | <i>=, Equal</i> |
| 1 | <i>!=, Not Equal</i> |
| 2 | <i>>, Greater Than</i> |
| 3 | <i>>=, Greater Than or Equal</i> |
| 4 | <i><, Less Than</i> |
| 5 | <i><=, Less Than or Equal</i> |

Table 13 – Table X – Condition Y, Operator Options

The three conditions are evaluated and if the result satisfies logical operation defined with **“Table X – Conditions Logical Operator”** setpoint, given in Table 14, the associated Lookup Table is selected as output of the Logical block. Option *‘0 – Default Table’* selects associated Lookup Table in all conditions.

| | |
|---|--------------------------------|
| 0 | <i>Default Table (Table1)</i> |
| 1 | <i>Cnd1 And Cnd2 And Cnd3</i> |
| 2 | <i>Cnd1 Or Cnd2 Or Cnd3</i> |
| 3 | <i>(Cnd1 And Cnd2) Or Cnd3</i> |
| 4 | <i>(Cnd1 Or Cnd2) And Cnd3</i> |

Table 14 – Table X – Conditions Logical Operator Options

The three logical operations are evaluated in order and the first to satisfy gets selected, thus if Table1 logical operation is satisfied, the Lookup Table associated with Table1 gets selected regardless of two other logical operations. In addition, if none of the logical operations is satisfied the Lookup Table associated with Table1 gets selected.

2.6. Math Function Block

There are four mathematical function blocks that allow the user to define basic algorithms. A math function block can take up to five input signals. Each input is then scaled according to the associated limit and scaling setpoints.

The mathematical block’s input signal value can have values in range -1000 to 1000. In case the signal value is larger than that, the “**Function X Input Y Minimum**” and “**Function X Input Y Maximum**” values can be used to rescale the value. For additional control the user can also adjust the “**Function X Input Y Scaler**”. By default, each input has a scaling ‘weight’ of 1.0 However, each input can be scaled from -1.0 to 1.0 as necessary before it is applied in the function.

A mathematical function block includes four selectable functions, which each implements equation $A \text{ operator } B$, where A and B are function inputs and operator is function selected with setpoint “**Math function X Operator**”. Setpoint options are presented in Table 15. The functions are connected together, so that result of the preceding function goes into Input A of the next function. Thus Function 1 has both Input A and Input B selectable with setpoints, where Functions 2 to 4 have only Input B selectable. Input is selected by setting “**Function X Input Y Source**” and “**Function X Input Y Number**”. If “**Function X Input B Source**” is set to 0 ‘Control not used’ signal goes through function unchanged.

$$\text{Math Block Output} = \left(\left((A1 \text{ op1 } B1) \text{ op2 } B2 \right) \text{ op3 } B3 \right) \text{ op4 } B4$$

| | |
|----|---------------------------------------------------------------|
| 0 | <i>=, True when InA equals InB</i> |
| 1 | <i>!=, True when InA not equal InB</i> |
| 2 | <i>>, True when InA greater than InB</i> |
| 3 | <i>>=, True when InA greater than or equal InB</i> |
| 4 | <i><, True when InA less than InB</i> |
| 5 | <i><=, True when InA less than or equal InB</i> |
| 6 | <i>OR, True when InA or InB is True</i> |
| 7 | <i>AND, True when InA and InB are True</i> |
| 8 | <i>XOR, True when either InA or InB is True, but not both</i> |
| 9 | <i>+, Result = InA plus InB</i> |
| 10 | <i>-, Result = InA minus InB</i> |
| 11 | <i>x, Result = InA times InB</i> |
| 12 | <i>/, Result = InA divided by InB</i> |
| 13 | <i>MIN, Result = Smallest of InA and InB</i> |
| 14 | <i>MAX, Result = Largest of InA and InB</i> |

| | |
|----|--------------------------------------------------------|
| 15 | <i>MAX-MIN, Result = Absolute value of (InA – InB)</i> |
| 16 | <i>SIN, Result = InA * SIN(InB)</i> |
| 17 | <i>COS, Result = InA * COS(InB)</i> |
| 18 | <i>SQRT, Result = InA * SQRT(InB)</i> |

Table 15 – Math function X Operator Options

For logic operations (6, 7, 8) scaled input greater or equal to 1 is treated as TRUE. For logic operations (0 to 5), the result of the function will always be 0 (FALSE) or 1 (TRUE). For the arithmetic functions (9 to 14), it is recommended to scale the data such that the resulting operation will not exceed full scale (-1e6 to 1e6) and saturate the output result.

When dividing, a zero divider will always result in a full (1e6) output value for the associated function.

Lastly the resulting mathematical calculation, presented as real value, can be scaled into the appropriate physical units using the “**Math Output Minimum Range**” and “**Math Output Maximum Range**” setpoints. These values are also used as the limits when the Math Function I selected as the input source for another function block.

2.7. Variable Data

In case run time settable, non-volatile data is required in the control algorithm, the Control Variable Data Blocks offer one possible solution. These function blocks contain a single variable with rules for updating the value at run time, without the need for the user to trigger the variable update process as it is done with the Control Constant Data Blocks.

The “**Variable Value**” setpoint shows the current value for the variable. This setpoint is user configurable, so it is possible to modify the value using EA.

“**Variable Value Data Source**” and “**Variable Data Data Number**” define the source from which the new Variable Data value is read at update event.

The variable data update process is controlled using the next five setpoints, namely “**Variable Value Update Trigger Source**”, “**Variable Value Update Trigger Number**”, “**Variable Value Update Trigger Threshold Source**”, “**Variable Value Update Trigger Threshold Number**” and “**Variable Value Update Function**”. The trigger number and source define the control signal to be compared with the trigger threshold control signal. The comparison is done using the logical (or mathematical) operator that can be selected using “**Variable Value Update Function**” setpoint.

In case the logical operation evaluates as *True* (for the Math functions, greater than zero) the variable data value is updated from the selected data source and the new value is stored into Flash memory. The save is done only once per evaluating the update function as *True*. Before the next save can happen, the update function must evaluate as *False* (for the Math functions, equal to zero) at least once. Also, the minimum time between two variable data saving events is set to 10 seconds (not user configurable limit).

2.8. Diagnostics Blocks

The 12IN-8SOUT Controller supports diagnostic messaging. DM1 is a message, containing Active Diagnostic Trouble Codes (DTC) that is sent to the J1939 network in case a fault has been detected. A Diagnostic Trouble Code is defined by the J1939 standard as a four-byte value.

In addition to supporting the DM1 message, the following are supported:

| | | |
|-----|--------------------------|------------------------------------------|
| SPN | Suspect Parameter Number | (user defined) |
| FMI | Failure Mode Identifier | (see Table 17 and Table 18) |
| CM | Conversion Method | (always set to 0) |
| OC | Occurrence Count | (number of times the fault has happened) |

| | | |
|------|-------------------------------------------------------|----------------------|
| DM2 | Previously Active Diagnostic Trouble Codes | Sent only on request |
| DM3 | Diagnostic Data Clear/Reset of Previously Active DTCs | Done only on request |
| DM11 | Diagnostic Data Clear/Reset for Active DTCs | Done only on request |

Fault detection and reaction is a standalone functionality that can be configured to monitor and report diagnostics of various controller parameters. The 12IN-8SOUT Controller supports 12 Diagnostics Definitions, each freely configurable by the user.

By default, the monitoring of operating voltage, CPU temperature and receive message timeouts is configured to diagnostics blocks 1, 2 and 3., In case any of these three diagnostics blocks are needed for some other use, the user can adjust the default settings to suit the application.

There are 4 fault types that can be used, “**Minimum and maximum error**”, “**Absolute value error**”, “**State error**” and “**Double minimum and maximum error**”.

Minimum and maximum error has two thresholds, “MIN Shutdown” and “MAX Shutdown” that have configurable, independent diagnostics parameters (SPN, FMI, Generate DTCs, delay before flagging status). In case the parameter to monitor stays between these two thresholds, the diagnostic is not flagged.

Absolute value error has one configurable threshold with configurable parameters. In case the parameter to monitor stays below this threshold, the diagnostic is not flagged.

State error is like the Absolute value error, the only difference is that State error does not allow the user to specify specific threshold values; thresholds ‘1’ and ‘0’ are used instead. This is ideal for monitoring state information, such as received message timeouts.

Double minimum and maximum error lets user to specify four thresholds, each with independent diagnostic parameters. The diagnostic status and threshold values is determined and expected as show in Figure 2 below.

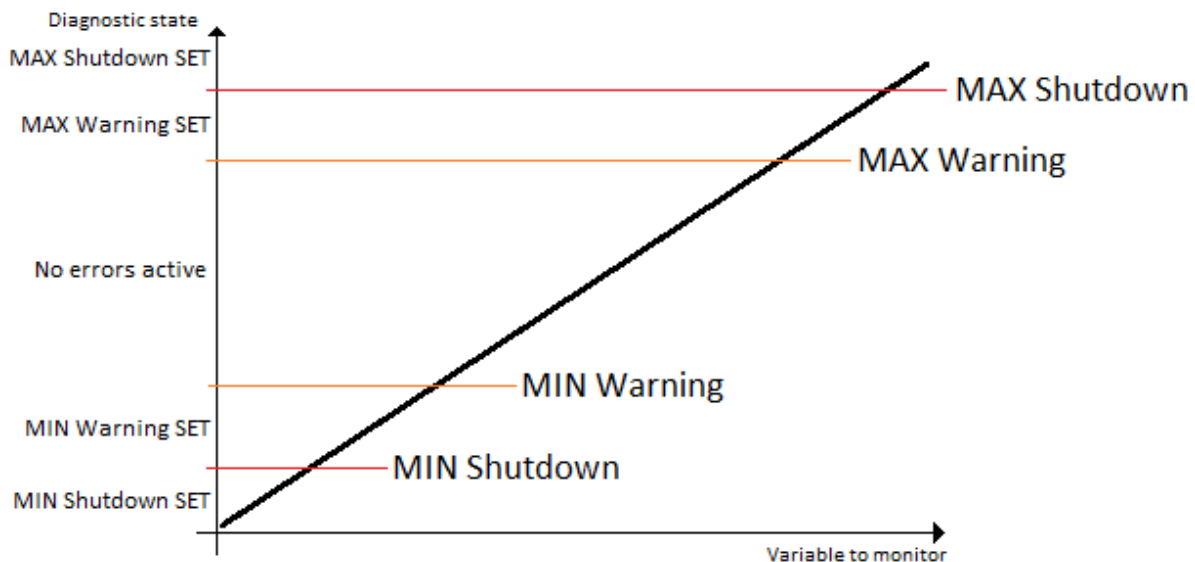

Figure 2 – Double Minimum and Maximum Error Thresholds

In case any of the Diagnostics blocks is configured to monitor Output Current Feedback, there is an internal error status flag maintained automatically for that output. This internal flag can be used for driving the output to a specified state in case of diagnostic event using Proportional Current Output setpoints “Control Fault Response”, “Output in Fault Mode” and “Fault Detection Enabled”.

There is also built in error status flags for power supply and CPU temperature monitoring. In case any of the diagnostics blocks is measuring these two parameters, the corresponding internal error status flags can be used for shutting down the unit in case of failure. The setpoints “**Power Fault Disables Outputs**” and “**Over Temperature Shutdown**” can be used for enabling the shutdown of the unit (shutdown == output driving is turned off).

While there are no active DTCs, the 12IN-8SOUT Controller will send “No Active Faults” message. If a previously inactive DTC becomes active, a DM1 will be sent immediately to reflect this. As soon as the last active DTC goes inactive, a DM1 indicating that there are no more active DTCs will be sent.

If there is more than one active DTC at any given time, the regular DM1 message will be sent using a multipacket message to the Requester Address using the Transport Protocol (TP).



At power up, the DM1 message will not be broadcasted until after 5 second delay. This is done to prevent any power up or initialization conditions from being flagged as an active error on the network.

When the fault is linked to a DTC, a non-volatile log of the occurrence count (OC) is kept. As soon as the controller detects a new (previously inactive) fault, it will start decrementing the “**Delay before Event is flagged**” timer for that Diagnostic function block. If the fault has remained present during the delay time, then the controller will set the DTC to active, and will increment the OC in the log. A DM1 will immediately be generated that includes the new DTC. The timer is provided so that intermittent faults do not overwhelm the network as the fault comes and goes, since a DM1 message would be sent every time the fault shows up or goes away.

By default, the fault flag is cleared when error condition that has caused it goes away. The DTC is made Previously Active and is it is no longer included in the DM1 message. To identify a fault having happened, even if the condition that has caused is one away, the “**Event Cleared only by DM11**” setpoint can be set to ‘True’. This configuration enables DTC to stay Active, even after the fault flag has been cleared, and be included in DM1 message until a Diagnostic Data Clear/Reset for Active DTCs (DM11) has been requested.

As defined by J1939 Standard the first byte of the DM1 message reflects the Lamp status. “**Lamp Set by Event**” setpoint determines the lamp type set in this byte of DTC. “**Lamp Set by Event**” setpoint options are listed in Table 16. By default, the ‘Amber, Warning’ lamp is typically the one set be any active fault.

| | |
|---|----------------------|
| 0 | <i>Protect</i> |
| 1 | <i>Amber Warning</i> |
| 2 | <i>Red Stop</i> |
| 3 | <i>Malfunction</i> |

Table 16 – Lamp Set by Event in DM1 Options

“**SPN for Event**” defines suspect parameter number used as part of DTC. The default value zero is not allowed by the standard, thus no DM will be sent unless “**SPN for Event**” in is configured to be different from zero. **It is user’s responsibility to select SPN that will not violate J1939 standard.** When the “**SPN for Event**” is changed, the OC of the associated error log is automatically reset to zero.

| | |
|----|------------------------------------------------------------------------------|
| 0 | <i>Data Valid But Above Normal Operational Range - Most Severe Level</i> |
| 1 | <i>Data Valid But Below Normal Operational Range - Most Severe Level</i> |
| 2 | <i>Data Intermittent</i> |
| 3 | <i>Voltage Above Normal, Or Shorted To High Source</i> |
| 4 | <i>Voltage Below Normal, Or Shorted To Low Source</i> |
| 5 | <i>Current Below Normal Or Open Circuit</i> |
| 6 | <i>Current Above Normal Or Grounded Circuit</i> |
| 7 | <i>Mechanical Error</i> |
| 8 | <i>Abnormal Frequency Or Pulse Width Or Period</i> |
| 9 | <i>Abnormal Update Rate</i> |
| 10 | <i>Abnormal Rate Of Change</i> |
| 11 | <i>Root Cause Not Known</i> |
| 12 | <i>Bad Component</i> |
| 13 | <i>Out Of Calibration</i> |
| 14 | <i>Special Instructions</i> |
| 15 | <i>Data Valid But Above Normal Operating Range – Least Severe Level</i> |
| 16 | <i>Data Valid But Above Normal Operating Range – Moderately Severe Level</i> |
| 17 | <i>Data Valid But Below Normal Operating Range – Least Severe Level</i> |
| 18 | <i>Data Valid But Below Normal Operating Range – Moderately Severe Level</i> |
| 19 | <i>Network Error</i> |
| 20 | <i>Data Drifted High</i> |
| 21 | <i>Data Drifted Low</i> |
| 31 | <i>Condition Exists</i> |

Table 17 – FMI for Event Options

Every fault has associated a default FMI with them. The used FMI can be configured with “**FMI for Event**” setpoint, presented in Table 17. When an FMI is selected from Low Fault FMIs in Table 18

for a fault that can be flagged either high or low occurrence, it is recommended that the user would select the high occurrence FMI from the right column of Table 18. There is no automatic setting of High and Low FMIs in the firmware, the user can configure these freely.

| Low Fault FMIs | High Fault FMIs |
|--------------------------------------------------------------------------------------|--------------------------------------------------------------------------------------|
| <i>FMI=1, Data Valid But Below Normal Operation Range – Most Severe Level</i> | <i>FMI=0, Data Valid But Above Normal Operational Range – Most Severe Level</i> |
| <i>FMI=4, Voltage Below Normal, Or Shorted to Low Source</i> | <i>FMI=3, Voltage Above Normal, Or Shorted To High Source</i> |
| <i>FMI=5, Current Below Normal Or Open Circuit</i> | <i>FMI=6, Current Above Normal Or Grounded Circuit</i> |
| <i>FMI=17, Data Valid But Below Normal Operating Range – Least Severe Level</i> | <i>FMI=15, Data Valid But Above Normal Operating Range – Least Severe Level</i> |
| <i>FMI=18, Data Valid But Below Normal Operating Level – Moderately Severe Level</i> | <i>FMI=16, Data Valid But Above Normal Operating Range – Moderately Severe Level</i> |
| <i>FMI=21, Data Drifted Low</i> | <i>FMI=20, Data Drifted High</i> |

Table 18 – Low Fault FMIs and corresponding High Fault FMIs

2.9. CAN Transmit Function Block

The CAN Transmit function block is used to send any output from another function block (i.e. input, CAN receive) to the J1939 network. The AX030210 ECU has twelve CAN Transmit Messages and each message has four completely user defined signals.

2.9.1. CAN Transmit Message Setpoints

Each CAN Transmit Message setpoint group includes setpoints that effect the whole message and are thus mutual for all signals of the message. These setpoints are presented in this section. The setpoints that configure an individual signal are presented in next section.

The “**Transmit PGN**” setpoint sets PGN used with the message. **User should be familiar with the SAE J1939 standard and select values for PGN/SPN combinations as appropriate from section J1939/71.**

“**Repetition Rate**” setpoint defines the interval used to send the message to the J1939 network. If the “**Repetition Rate**” is set to zero, the message is disabled unless it shares its PGN with another message. In case of a shared PGN repetition rate of the LOWEST numbered message are used to send the message ‘bundle’.



At power up, transmitted message will not be broadcasted until after a 5 second delay. This is done to prevent any power up or initialization conditions from creating problems on the network.

2.9.2. CAN Transmit Signal Setpoints

Each CAN transmit message has four associated signals, which define data inside the Transmit message. “**Control Source**” setpoint together with “**Control Number**” setpoint define the signal source of the message. “**Control Source**” and “**Control Number**” options are listed in **Table 19**. Setting “**Control Source**” to ‘*Control Not Used*’ disables the signal.

“**Transmit Data Width**” setpoint determines how many bits signal reserves from the message. “**Transmit Data Index in Array**” determines in which of 8 bytes of the CAN message LSB of the signal is located. Similarly, “**Transmit Bit Index in Byte**” determines in which of 8 bits of a byte the LSB is located. These setpoints are freely configurable, thus **it is the User’s responsibility to ensure that signals do not overlap and mask each other.**

“Transmit Data Resolution” setpoint determines the scaling done on the signal data before it is sent to the bus. “Transmit Data Offset” setpoint determines the value that is subtracted from the signal data before it is scaled. Offset and Resolution are interpreted in units of the selected source signal.

2.10. CAN Receive Function Block

The CAN Receive function block is designed to take any SPN from the J1939 network and use it as an input to another function block (i.e. Outputs).

The “**Receive Message Enabled**” is the most important setpoint associated with this function block and it should be selected first. Changing it will result in other setpoints being enabled/disabled as appropriate. By default, ALL receive messages are disabled.

Once a message has been enabled, a Lost Communication fault will be flagged if that message is not received off the bud within the “**Receive Message Timeout**” period. This could trigger a Lost Communication event as described in section 2.8. To avoid timeouts on a heavily saturated network, it is recommended to set the period at least three times longer than the expected update rate. To disable the timeout feature, simply set this value to zero, in which case the received message will never trigger a Lost Communication fault.

The “**Receive Data Width**”, “**Receive Data Index in Array (LSB)**”, “**Receive Bit Index in Byte (LSB)**”, “**Receive Resolution**” and “**Receive Offset**” can all be used to map any SPN supported by the J1939 standard to the output data of the Received function block.

A CAN receive function clock can be selected as the source of the control input for the output function blocks. When this is case, the “**Received Data Min (Off Threshold)**” and “**Received Data Max (On Threshold)**” setpoints determine the minimum and maximum values of the control signal. As the names imply, they are also used as the On/Off thresholds for digital output types. These values are in whatever units the data is AFTER the resolution and offset is applied to CAN receive signal.

The 12IN-8SOUT Controller I/O supports up to eight unique CAN Receive Messages.

2.11. DTC React

The DTC React function block is a very simple function which will allow a received DTC, sent from another ECU on a DM1 message, to disable an output or be used as input to another type of logic block. Up to five SPN/FMI combinations can be selected.

Should a DM1 message be received with the SPN/FMI combination defined, the corresponding DTC State will be set to ON. Once ON, if the same SPN/FMI combination has not been received again after 3 seconds, the DTC State will be reset to OFF.

The DTC could be used as a digital (on/off) input for any function block as appropriate.

2.12. Available Control Sources

Many of the Function Blocks have selectable input signals, which are determined with “[Name] Source” and “[Name] Number” setpoints. Together, these setpoints uniquely select how the I/O of the various function blocks are linked together. “[Name] Source” setpoint determines the type of the source and “[Name] Number” selects the actual source if there is more than one of the same type. Available “[Name] Source” options and associated “[Name] Number” ranges are listed in Table 19. All sources, except “CAN message reception timeout”, are available for all blocks, including output control blocks and CAN Transmit messages. Thought input Sources are freely selectable, not all options would make sense for any input, and it is up to the user to program the controller in a logical and functional manner.

| Sources | Number Range | Notes |
|-------------------------------------|--------------|-----------------------------------------------------------------------------------------------------------------------------------------------------------------------|
| 0: Control Not Used | N/A | When this is selected, it disables all other setpoints associated with the signal in question. |
| 1: Received CAN Message | 1 to 8 | User must enable the function block, as it is disabled by default. |
| 2: Universal/Digital Input Measured | 1 to 12 | |
| 3: PID Function Block | 1 to 2 | User must enable the function block, as it is disabled by default. |
| 4: Lookup Table | 1 to 10 | |
| 5: Programmable Logic Block | 1 to 2 | User must enable the function block, as it is disabled by default. |
| 6: Math Function Block | 1 to 4 | User must enable the function block, as it is disabled by default. |
| 7: Control Constant Data | 1 to 15 | 1 = FALSE, 2 = TRUE, 3 to 15 = User Selectable |
| 8: Diagnostic Trouble Code | 1 to 5 | Will only be valid if the corresponding DTC has a non-zero SPN |
| 9: Output Target Drive | 1 to 9 | Output drive target value. |
| 10: Measured Reference Voltage | 1 to 2 | Measured reference voltage in Volts. |
| 11: Power Supply Measured | 0 to 255 | Measured power supply value in Volts. The Parameter sets the threshold in Volts to compare with. In case Parameter is set to '0', the measured value is used as is. |
| 12: Processor Temperature Measured | 0 to 255 | Measured processor temperature in °C. The Parameter sets the threshold in Celcius to compare with. In case Parameter is set to '0', the measured value is used as is. |
| 13: CAN Reception Timeout | N/A | |
| 14: Control Variable Data | 1 to 2 | Variable data. |
| 15: DAC Status | 1 to 3 | Signal Outputs' DAC status. Number 3 reads '0' if output fault is active. |

Table 19 – Available Control Sources and Numbers

If a non-digital signal is selected to drive a Universal Input in digital input mode, the signal is interpreted to be OFF at or below the minimum of selected source and ON at or above the maximum of the selected source, and it will not change in between those points. Thus, analog to digital interpretation has a built in hysteresis defined by minimum and maximum of the selected source, as shown in Figure 3. A Universal Input signal is interpreted to be ON at or above “**Maximum Range**” and OFF at or below “**Minimum Range**”.

Control Constant Data has no unit nor minimum and maximum assigned to it, thus user must assign appropriate constant values according to intended use.

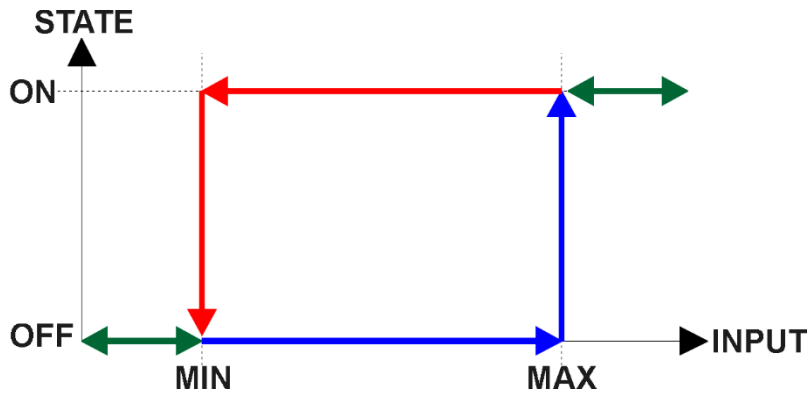

Figure 3 – Analog source to Digital input

3. Installation Instructions

3.1. Dimensions and Pinout

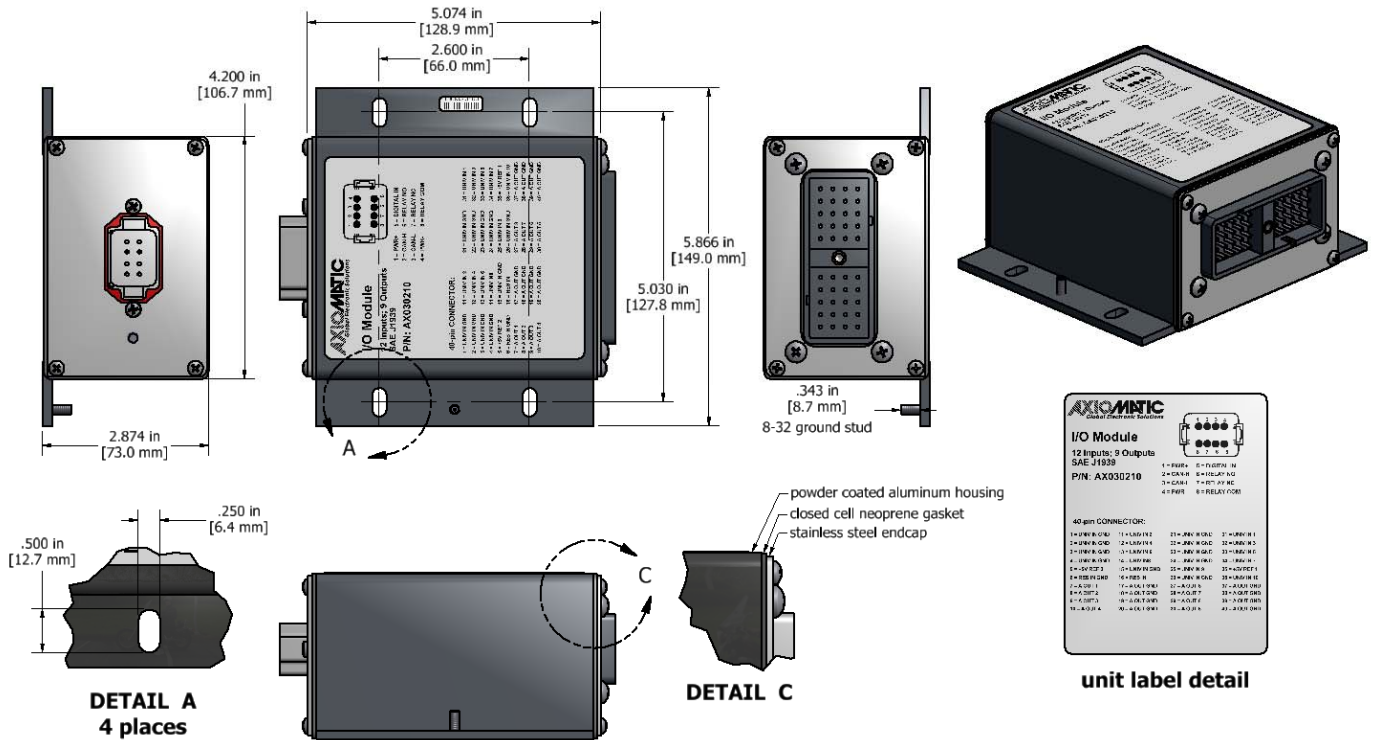

Figure 4 – AX030210 Dimensional Drawing

| PIN# | Description |
|------|---------------------------|
| 1 | BATT + |
| 2 | CAN H |
| 3 | CAN L |
| 4 | BATT - |
| 5 | DIGITAL INPUT |
| 6 | Relay Output NO |
| 7 | Relay Output NC |
| 8 | Relay Output COM |
| 9 | ANALOG OUTPUT 1 |
| 10 | ANALOG OUTPUT 2 |
| 11 | CAN H |
| 12 | CAN L |
| 13 | CAN H |
| 14 | CAN L |
| 15 | CAN H |
| 16 | CAN L |
| 17 | ANALOG OUTPUT 3 |
| 18 | ANALOG OUTPUT 4 |
| 19 | ANALOG OUTPUT 5 |
| 20 | ANALOG OUTPUT 6 |
| 21 | UNIVERSAL INPUT 1_GND |
| 22 | UNIVERSAL INPUT 3_GND |
| 23 | UNIVERSAL INPUT 5_GND |
| 24 | UNIVERSAL INPUT 7_GND |
| 25 | UNIVERSAL SIGNAL INPUT 9 |
| 26 | UNIVERSAL INPUT 10_GND |
| 27 | ANALOG OUTPUT 8 |
| 28 | ANALOG OUTPUT 7 |
| 29 | ANALOG OUTPUT 6 |
| 30 | ANALOG OUTPUT 5 |
| 31 | UNIVERSAL SIGNAL INPUT 1 |
| 32 | UNIVERSAL SIGNAL INPUT 3 |
| 33 | UNIVERSAL SIGNAL INPUT 5 |
| 34 | UNIVERSAL SIGNAL INPUT 7 |
| 35 | +V Reference 1 |
| 36 | UNIVERSAL SIGNAL INPUT 10 |
| 37 | ANALOG OUTPUT_GND |
| 38 | ANALOG OUTPUT_GND |
| 39 | ANALOG OUTPUT_GND |
| 40 | ANALOG OUTPUT_GND |

Table 20 – AX030210 Connector Pinouts

4. Overview of the J1939 Features

The software was designed to provide flexibility to the user with respect to messages sent from the ECU by providing:

- Configurable ECU Instance in the NAME (to allow multiple ECUs on the same network)
- Configurable Input Parameters
- Configurable PGN and Data Parameters
- Configurable Diagnostic Messaging Parameters, as required
- Diagnostic Log, maintained in non-volatile memory

4.1. Introduction to Supported Messages

The ECU is compliant with the standard SAE J1939, and supports following PGNs from the standard.

From J1939-21 – Data Link Layer

- | | | |
|----------------------------------------------|------------|----------|
| • Request | 59904 | 0x00EA00 |
| • Acknowledgement | 59392 | 0x00E800 |
| • Transport Protocol – Connection Management | 60416 | 0x00EC00 |
| • Transport Protocol – Data Transfer Message | 60160 | 0x00EB00 |
| • Proprietary B | from 65280 | 0x00FF00 |
| | to 65535 | 0x00FFFF |

From J1939-73 – Diagnostics

- | | | |
|----------------------------------------------------------------|-------|----------|
| • DM1 – Active Diagnostic Trouble Codes | 65226 | 0x00FECA |
| • DM2 – Previously Active Diagnostic Trouble Codes | 65227 | 0x00FECB |
| • DM3 – Diagnostic Data Clear/Reset for Previously Active DTCs | 65228 | 0x00FECC |
| • DM11 – Diagnostic Data Clear/Reset for Active DTCs | 65235 | 0x00FED3 |
| • DM14 – Memory Access Request | 55552 | 0x00D900 |
| • DM15 – Memory Access Response | 55296 | 0x00D800 |
| • DM16 – Binary Data Transfer | 55040 | 0x00D700 |

From J1939-81 – Network Management

- | | | |
|--------------------------------|-------|----------|
| • Address Claimed/Cannot Claim | 60928 | 0x00EE00 |
| • Commanded Address | 65240 | 0x00FED8 |

From J1939-71 – Vehicle Application Layer

- | | | |
|---------------------------|-------|----------|
| • Software Identification | 65242 | 0x00FEDA |
|---------------------------|-------|----------|

None of the application layer PGNs are supported as part of the default configurations, but they can be selected as desired for transmit function blocks.

Setpoints are accessed using standard Memory Access Protocol (MAP) with proprietary addresses. The Electronic Assistant[®] (EA) allows for quick and easy configuration of the unit over CAN network.

4.2. NAME, Address and Software ID

The 12IN-8SOUT Controller I/O ECU has the following default for the J1939 NAME. The user should refer to the SAE J1939/81 standard for more information on these parameters and their ranges.

| | |
|---------------------------|---------------------------------------------------------------------|
| Arbitrary Address Capable | Yes |
| Industry Group | 0, Global |
| Vehicle System Instance | 0 |
| Vehicle System | 0, Non-specific system |
| Function | 126, Axiomatic I/O Controller |
| Function Instance | 4, Axiomatic AX030210 |
| ECU Instance | 0, First Instance |
| Manufacture Code | 162, Axiomatic Technologies |
| Identity Number | Variable, uniquely assigned during factory programming for each ECU |

The ECU Instance is a configurable setpoint associated with the NAME. Changing this value will allow multiple ECUs of this type to be distinguishable from one another when they are connected on the same network.

The default value of the “ECU Address” setpoint is 128 (0x80), which is the preferred starting address for self-configurable ECUs as set by the SAE in J1939 tables B3 and B7. The EA will allow the selection of any address between 0 and 253. ***It is the user’s responsibility to select an address that complies with the standard.*** The user must also be aware that since the unit is arbitrary address capable, if another ECU with a higher priority NAME contends for the selected address, the 12IN-8SOUT controller will continue select the next highest address until it finds one that it can claim. See J1939/81 for more details about address claiming.

Software Identifier

| | | | |
|-------------------------------|---------------------------------|---------------------------------------------------|-----|
| PGN 65242 | Software Identification | - SOFT | |
| Transmission Repetition Rate: | On request | | |
| Data Length: | Variable | | |
| Extended Data Page: | 0 | | |
| Data Page: | 0 | | |
| PDU Format: | 254 | | |
| PDU Specific: | 218 PGN Supporting Information: | | |
| Default Priority: | 6 | | |
| Parameter Group Number: | 65242 (0xFEDA) | | |
| Start Position | Length | Parameter Name | SPN |
| 1 | 1 Byte | Number of software identification fields | 965 |
| 2-n | Variable | Software identification(s), Delimiter (ASCII “*”) | 234 |

Byte 1 is set to 5, and the identification fields are as follows.

| |
|-------------------------------------------------------------|
| (Part Number)*(Version)*(Date)*(Owner)*(Description) |
|-------------------------------------------------------------|

The EA shows all this information in “General ECU Information”, as shown below.

Note: The information provided in the Software ID is available for any J1939 service tool which supports the PGN -SOFT.

5. ECU Setpoints Accessed with Electronic Assistant

This section describes in detail each setpoint, and their default and ranges. Default values presented in tables are values used when setpoint in question is active. Many of the setpoints are dependent on other setpoints and they may not be active by default. Associated Figures show screen capture of initial operation, however some of the setpoints are not in default condition as they are set differently to activate more setpoints for the image. The setpoints are divided into setpoint groups as they are shown in EA. For more information on how each setpoint is used by 12IN-8SOUT controller, refer to the relevant section in this user manual.

5.1. Accessing the ECU Using EA

ECU with P/N AX030210 does not need any specific setup for EA. To access the high-speed versions, AX030210-01 and/or AX030210-02, the CAN bus Baud Rate needs to be set accordingly. The CAN Interface Setup can be found from “Options” menu in EA.

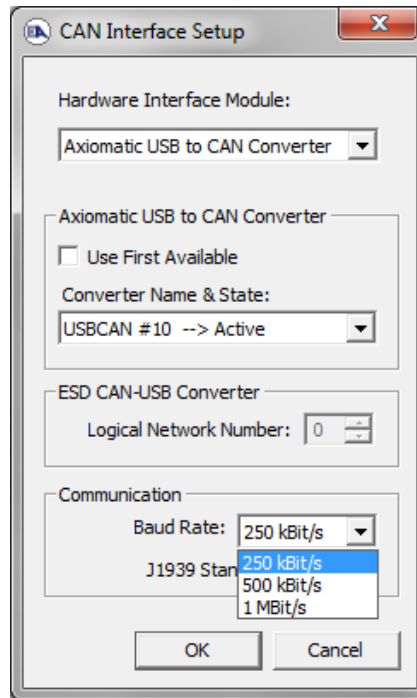

5.2. J1939 Network Parameters

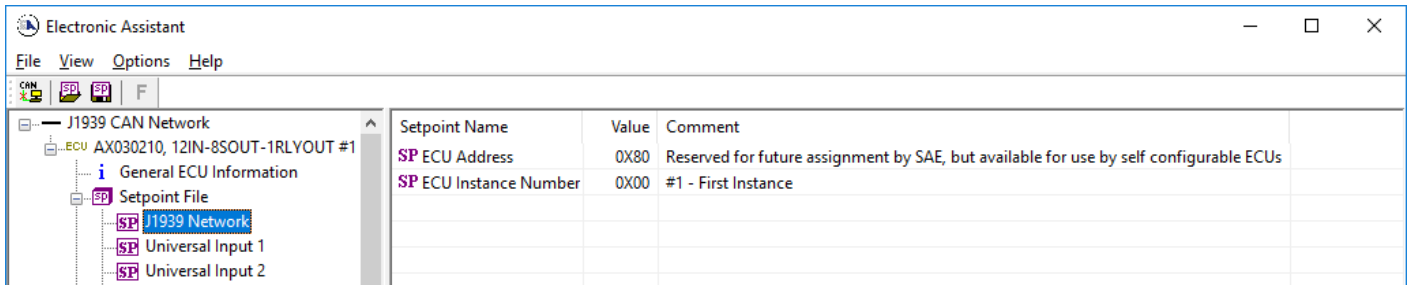

Figure 5 – Screen Capture of J1939 Setpoints

| Name | Range | Default | Notes |
|--------------|-------|---------|-----------------------------------------------|
| ECU Address | 0x80 | 0-253 | Preferred address for a self-configurable ECU |
| ECU Instance | 0-7 | 0x00 | Per J1939-81 |

Table 21 – J1939 Network Setpoints

If non-default values for the “**ECU Instance Number**” or “**ECU Address**” are used, they will be mirrored during a setpoint file flashing, and will only take effect once the entire file has been downloaded to the unit. After the setpoint flashing is complete, the unit will claim the new address and/or re-claim the address with the new NAME. If these setpoints are changing, it is recommended to close and re-open the CAN connection on EA after the file is loaded so that only the new NAME and address are showing in the J1939 CAN Network ECU list.

5.3. Universal Input Setpoints

The Universal Inputs are defined in Section 2.1.

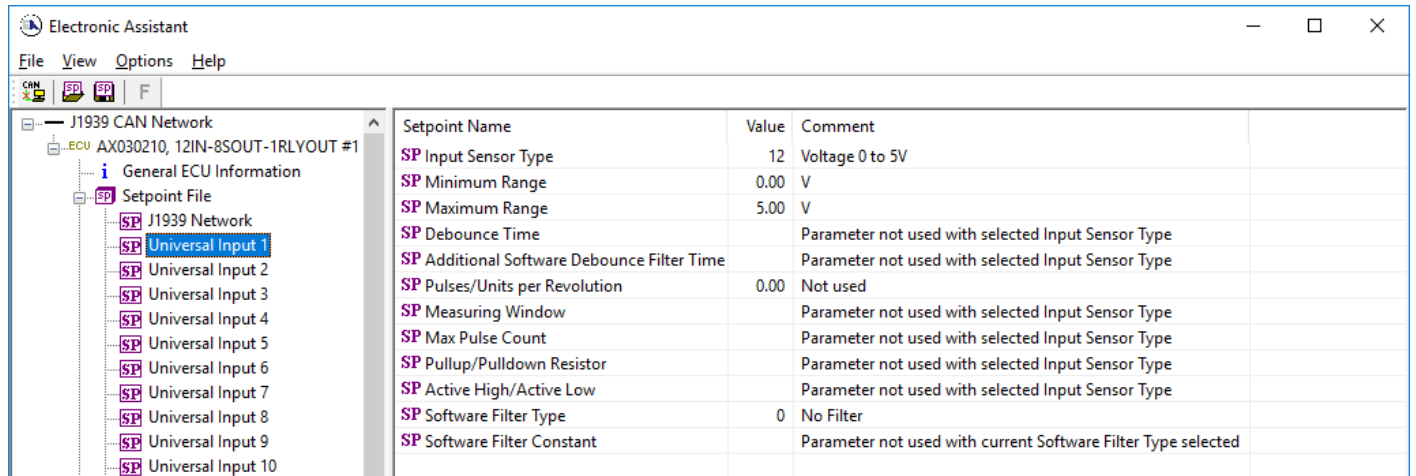

Figure 6 – Screen Capture of Universal Input Setpoints

| Name | Range | Default | Notes |
|------------------------------------------|------------------------------|------------------------------|-----------------|
| Input Sensor Type | Drop List | VOLTAGE_0_TO_5V | See Table 1 |
| Minimum Range | Depends on Input Sensor Type | Depends on Input Sensor Type | |
| Maximum Range | Depends on Input Sensor Type | Depends on Input Sensor Type | |
| Debounce Time | Drop List | None | See Table 2 |
| Additional Software Debounce Filter Time | Drop List | 0ms | See Table 3 |
| Pulses/Units per Revolution | Drop List | 0 | See Section 2.1 |
| Measuring Window | 1 ... 65535 | 1000 | |
| Max Pulse Count | 1 ... 65535 | 10 | |
| Pullup/Pulldown Resistor | Drop List | 22kΩ Pulldown | See Table 4 |
| Active High/Active Low | Drop List | Active High | See Table 5 |
| Software Filter Type | Drop List | No Filtering | See Table 8 |
| Software Filter Constant | 1..1000 | 1 | |

Table 22 – Universal Input Setpoints

5.4. Resistive Input Setpoints

The Resistive Input is defined in Section 2.1.1

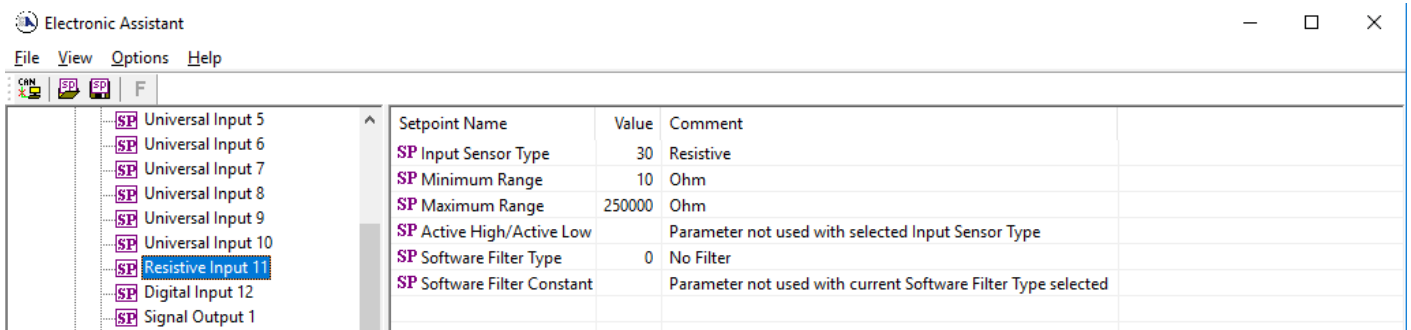

Figure 7 – Screen Capture of Resistive Input Setpoints

| Name | Range | Default | Notes |
|--------------------------|------------------------|--------------|---------------------|
| Input Sensor Type | Drop List | Resistive | Resistive / Digital |
| Minimum Range | 10 – Maximum Range | 10 | |
| Maximum Range | Minimum Range – 250000 | 250000 | |
| Active High/Active Low | Drop List | Active High | |
| Software Filter Type | Drop List | No Filtering | See Table 8 |
| Software Filter Constant | 1..1000 | 1 | |

Table 23 – Resistive Input Setpoints

5.5. Digital Input Setpoints

The Digital Input is defined in Section 2.1.2

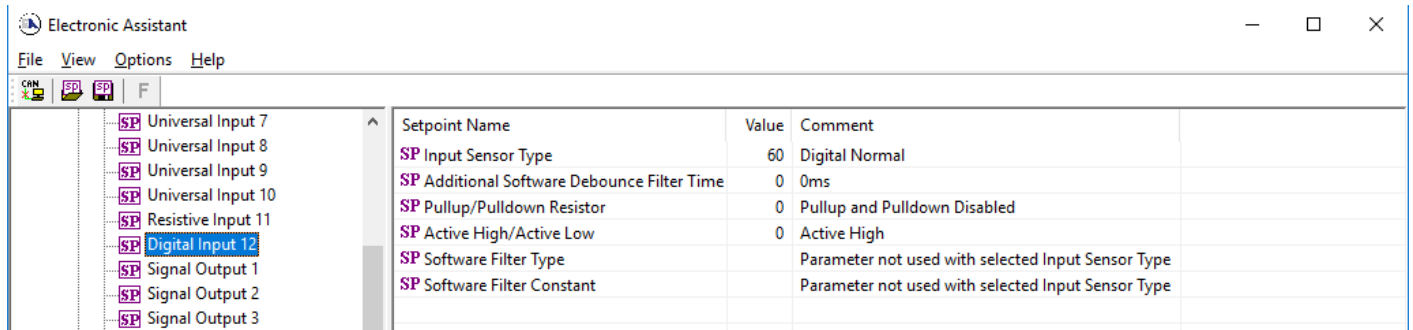

Figure 8 – Screen Capture of Digital Input Setpoints

| Name | Range | Default | Notes |
|------------------------------------------|-----------|----------------|-------------|
| Input Sensor Type | Drop List | Digital Normal | |
| Additional Software Debounce Filter Time | Drop List | 0ms | See Table 3 |
| Pullup/Pulldown Resistor | Drop List | 22kΩ Pulldown | See Table 4 |
| Active High/Active Low | Drop List | Active High | See Table 5 |
| Software Filter Type | Drop List | No Filtering | See Table 8 |
| Software Filter Constant | 1..1000 | 1 | |

Table 24 – Digital Input Setpoints

5.6. Signal Output Setpoints

The Signal Output is defined in Section 2.2

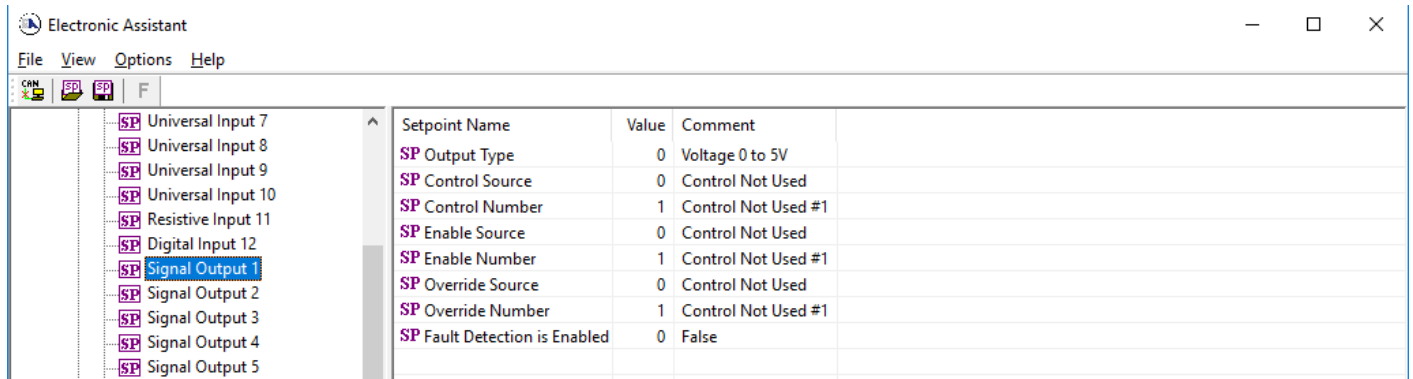

Figure 9 – Screen Capture of Signal / Output Setpoints

| Name | Range | Default | Notes |
|-----------------|-----------|------------------|--------------|
| Output Type | Drop List | Voltage 0 to 5V | See Table 9 |
| Control Source | Drop List | Control Not Used | See Table 19 |
| Control Number | Drop List | 1 | See Table 19 |
| Enable Source | Drop List | Control Not Used | See Table 19 |
| Enable Number | Drop List | 1 | See Table 19 |
| Override Source | Drop List | Control Not Used | See Table 19 |
| Override Number | Drop List | 1 | See Table 19 |

Table 25 – Signal Output Setpoints

5.7. Relay Output Setpoints

The Relay Output is defined in Section 2.2.1

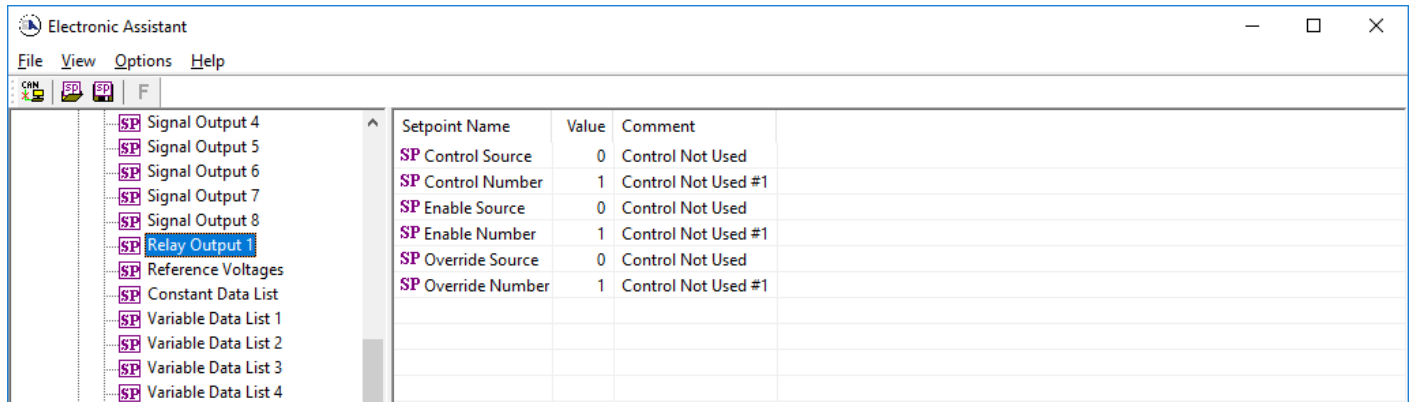

Figure 10 – Screen Capture of Relay Output Setpoints

| Name | Range | Default | Notes |
|-----------------|-----------|------------------|--------------|
| Control Source | Drop List | Control Not Used | See Table 19 |
| Control Number | Drop List | 1 | See Table 19 |
| Enable Source | Drop List | Control Not Used | See Table 19 |
| Enable Number | Drop List | 1 | See Table 19 |
| Override Source | Drop List | Control Not Used | See Table 19 |
| Override Number | Drop List | 1 | See Table 19 |

Table 26 – Relay Output Setpoints

5.8. Reference Voltage Setpoints

The Reference Voltage is defined in Section 2.2.2

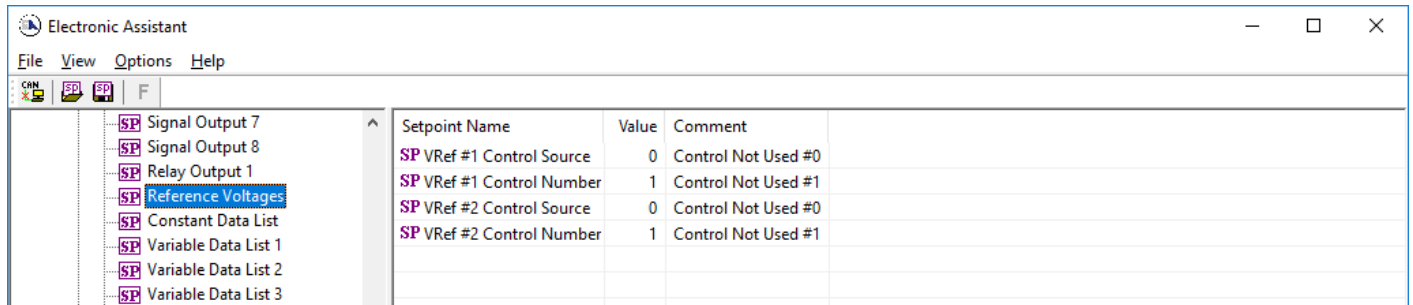

Figure 11 – Screen Capture of Reference Voltage Setpoints

| Name | Range | Default | Notes |
|------------------------|-----------|------------------|--------------|
| VRef #1 Control Source | Drop List | Control Not Used | See Table 19 |
| VRef #1 Control Number | Drop List | 1 | See Table 19 |
| VRef #2 Control Source | Drop List | Control Not Used | See Table 19 |
| VRef #2 Control Number | Drop List | 1 | See Table 19 |

Table 27 – Reference Voltage Setpoints

5.9. Constant Data List Setpoints

The Constant Data List Function Block is provided to allow the user to select values as desired for various logic block functions.

The first two constants are fixed values of 0 (False) and 1 (True) for use in binary logic. The remaining 13 constants are fully user programmable to any value between +/- 1 000 000. The default values are arbitrary and should be configured by the user as appropriate for their application.

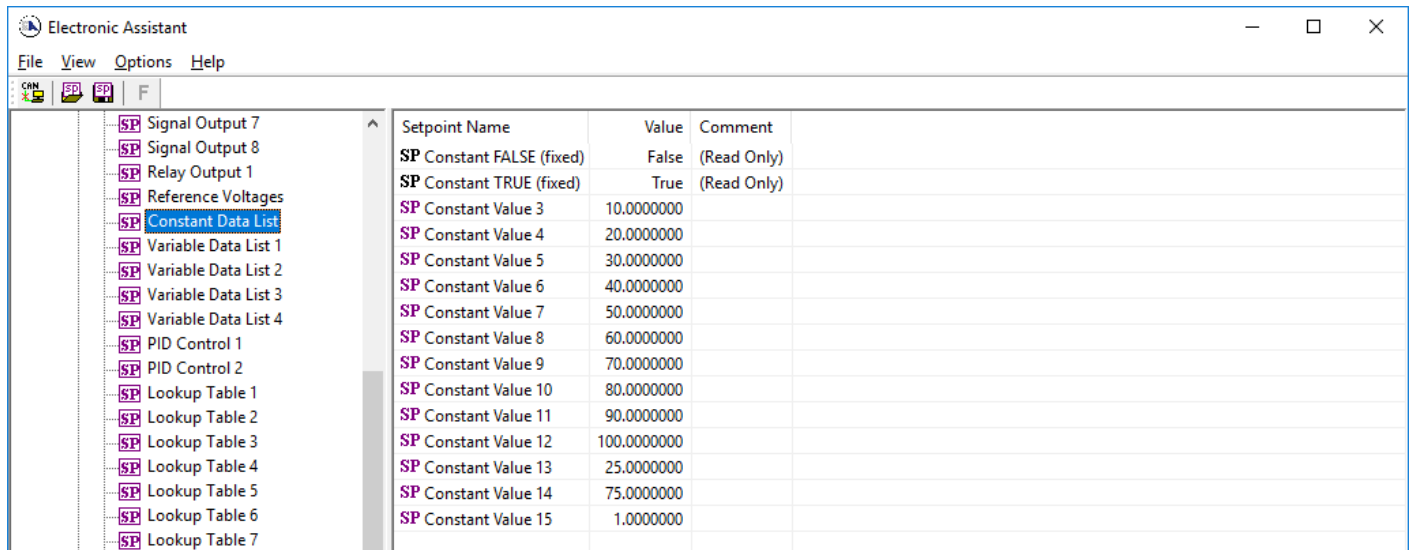

| Setpoint Name | Value | Comment |
|---------------------------|-------------|-------------|
| SP Constant FALSE (fixed) | False | (Read Only) |
| SP Constant TRUE (fixed) | True | (Read Only) |
| SP Constant Value 3 | 10.0000000 | |
| SP Constant Value 4 | 20.0000000 | |
| SP Constant Value 5 | 30.0000000 | |
| SP Constant Value 6 | 40.0000000 | |
| SP Constant Value 7 | 50.0000000 | |
| SP Constant Value 8 | 60.0000000 | |
| SP Constant Value 9 | 70.0000000 | |
| SP Constant Value 10 | 80.0000000 | |
| SP Constant Value 11 | 90.0000000 | |
| SP Constant Value 12 | 100.0000000 | |
| SP Constant Value 13 | 25.0000000 | |
| SP Constant Value 14 | 75.0000000 | |
| SP Constant Value 15 | 1.0000000 | |

Figure 12 - Screen Capture of Constant Data List Setpoints

5.10. Variable Data List Setpoints

The Variable Data List Function Block is provided to allow the user to select values as desired for various logic block functions and defining rule for updating this data at run time. This functionality is explained in more detail in section 2.7.

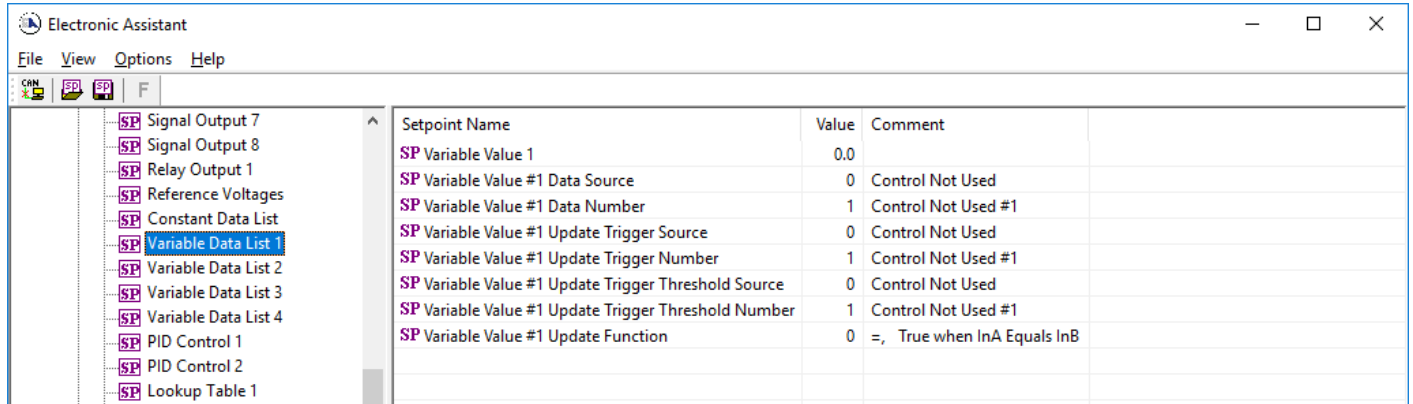

Figure 13 – Screen Capture of Variable Data List Setpoints

| Name | Range | Default | Notes |
|------------------------------------------------|---------------------------|------------------|--------------|
| Variable Value | | 0 | |
| Variable Value Data Source | Drop List | Control Not Used | See Table 19 |
| Variable Value Data Number | Depends on control source | 1 | See Table 19 |
| Variable Value Update Trigger Source | Drop List | Control Not Used | See Table 19 |
| Variable Value Update Trigger Number | Depends on control source | 1 | See Table 19 |
| Variable Value Update Trigger Threshold Source | Drop List | Control Not Used | See Table 19 |
| Variable Value Update Trigger Threshold Number | Depends on control source | 1 | See Table 19 |
| Variable Value Update Function | 0...17 | 0 | See Table 15 |

Table 28 – Variable Data Setpoints

5.11. PID Control

The PID Control Function Block is defined in Section 2.2.1. Please refer there for detailed information about how all these setpoints are used.

Command Source is set to ‘Control Not Used’ by default. To enable a PID Control, select appropriate “PID Target Command Source” and “PID Feedback Input Source”.

| Setpoint Name | Value | Comment |
|----------------------------------------|-------|--------------------------------------------------------|
| SP PID Target Command Source | 1 | Received CAN Message |
| SP PID Target Command Number | 1 | Received CAN Message #1 |
| SP PID Feedback Input Source | 2 | Universal/Digital Input Measured |
| SP PID Feedback Input Number | 1 | Universal/Digital Input Measured #1 |
| SP PID Enable Source | 0 | Control Not Used |
| SP PID Enable Number | | Parameter not used with current Enable Source selected |
| SP PID Enable Limit Source | | Parameter not used with current Enable Source selected |
| SP PID Enable Limit Number | | Parameter not used with current Enable Source selected |
| SP PID Enable Limit Parameter | | Parameter not used with current Enable Source selected |
| SP PID Response Profile | 0 | Single Output |
| SP PID Delta Tolerance | 1.00 | % |
| SP PID Loop Update Rate | 10 | ms |
| SP PID Gain Coefficient, G | 0.5 | |
| SP PID Integral Time Coefficient, Ti | 0.005 | Sec |
| SP PID Derivative Time Coefficient, Td | 0.001 | Sec |
| SP PID Integral Coefficient, Ki | 1.000 | |
| SP PID Derivative Coefficient, Kd | 1.000 | |

Figure 14 – Screen Capture of PID Control Setpoints

| Name | Range | Default | Notes |
|-------------------------------------|---------------------------|------------------|--------------------------------|
| PID Target Command Source | Drop List | Control Not Used | See Table 19 |
| PID Target Command Number | Depends on control source | 1 | See Table 19 |
| PID Feedback Input Source | Drop List | Control Not Used | See Table 19 |
| PID Feedback Input Number | Depends on control source | 1 | See Table 19 |
| PID Enable Source | Drop List | Control Not Used | See Table 19 |
| PID Enable Number | Depends on control source | 1 | See Table 19 |
| PID Enable Limit Source | Drop List | Control Not Used | See Table 19 |
| PID Enable Limit Number | Depends on control source | 1 | See Table 19 |
| PID Enable Limit Parameter | Drop List | 0 | |
| PID Response Profile | Drop List | Single Output | See Table 10 |
| PID Delta Tolerance | 0 to 100 | 1.00 % | % |
| PID Loop Update Rate | 1 to 60 000 ms | 10ms | 1 ms resolution |
| PID Gain Coefficient, G | 0.1 to 1000 | 0.5 | See Equation 3 |
| PID Integral Time Coefficient, Ti | 0.001 to 10 Sec | 0.005 Sec | 0.001 Sec (1ms) resolution |
| PID Derivative Time Coefficient, Td | 0.001 to 10 Sec | 0.001 Sec | 0.001 Sec (1ms) resolution |
| PID Integral Coefficient, Ki | 0 to 10 | 1.000 | 0 disables integral, PD ctrl |
| PID Derivative Coefficient, Kd | 0 to 10 | 1.000 | 0 disables derivative, PI ctrl |

Table 29 – PID Control Setpoints

5.12. Lookup Table

The Lookup Table Function Block is defined in Section 2.4. Please refer there for detailed information about how all these setpoints are used. “**X-Axis Source**” is set to ‘*Control Not Used*’ by default. To enable a Lookup Table, select appropriate “**X-Axis Source**”.

The screenshot shows the 'Electronic Assistant' window with a menu bar (File, View, Options, Help) and a toolbar. The main area is divided into a left-hand tree view and a right-hand table. The tree view lists various function blocks, including Signal Output, Reference Voltages, Variable Data Lists, PID Control, Lookup Tables (1-10), Programmable Logic, Math Function Blocks, CAN Transmit (1-12), and CAN Receive (1-4). The right-hand table displays the setpoints for the selected 'Lookup Table' function block.

| Setpoint Name | Value | Comment |
|-------------------------------|---------|---------------------------------------------------------|
| SP X-Axis Source | 2 | Universal/Digital Input Measured |
| SP X-Axis Number | 1 | Universal/Digital Input Measured #1 |
| SP X-Axis Type | 0 | Data Response |
| SP Disable limit (X Value) | | Parameter not used with current Control Source selected |
| SP Enable limit (X Value) | | Parameter not used with current Control Source selected |
| SP Output value when disabled | | Parameter not used with current Control Source selected |
| SP Table Auto-Cycle | | Parameter not used with selected X-Axis Type |
| SP Point 1 - Response | 1 | Ramp To |
| SP Point 2 - Response | 1 | Ramp To |
| SP Point 3 - Response | 1 | Ramp To |
| SP Point 4 - Response | 1 | Ramp To |
| SP Point 5 - Response | 1 | Ramp To |
| SP Point 6 - Response | 1 | Ramp To |
| SP Point 7 - Response | 1 | Ramp To |
| SP Point 8 - Response | 1 | Ramp To |
| SP Point 9 - Response | 1 | Ramp To |
| SP Point 10 - Response | 1 | Ramp To |
| SP Point 0 - X Value | 0.000 | |
| SP Point 1 - X Value | 0.500 | |
| SP Point 2 - X Value | 1.000 | |
| SP Point 3 - X Value | 1.500 | |
| SP Point 4 - X Value | 2.000 | |
| SP Point 5 - X Value | 2.500 | |
| SP Point 6 - X Value | 3.000 | |
| SP Point 7 - X Value | 3.500 | |
| SP Point 8 - X Value | 4.000 | |
| SP Point 9 - X Value | 4.500 | |
| SP Point 10 - X Value | 5.000 | |
| SP Point 0 - Y Value | 0.000 | |
| SP Point 1 - Y Value | 10.000 | |
| SP Point 2 - Y Value | 20.000 | |
| SP Point 3 - Y Value | 30.000 | |
| SP Point 4 - Y Value | 40.000 | |
| SP Point 5 - Y Value | 50.000 | |
| SP Point 6 - Y Value | 60.000 | |
| SP Point 7 - Y Value | 70.000 | |
| SP Point 8 - Y Value | 80.000 | |
| SP Point 9 - Y Value | 90.000 | |
| SP Point 10 - Y Value | 100.000 | |

Figure 15 – Screen Capture of Lookup table Setpoints

| Name | Range | Default | Notes |
|---------------------|----------------------------------------------------|--------------------------------|-----------------|
| X-Axis Source | Drop List | Control Not Used | See Table 19 |
| X-Axis Number | Depends on control source | 1 | See Table 19 |
| X-Axis Type | Drop List | Data Response | See Table 11 |
| Table Auto-Cycle | Drop List | 0 | |
| Point 1 - Response | Drop List | Ramp To | See Table 12 |
| Point 2 - Response | Drop List | Ramp To | See Table 12 |
| Point 3 - Response | Drop List | Ramp To | See Table 12 |
| Point 4 - Response | Drop List | Ramp To | See Table 12 |
| Point 5 - Response | Drop List | Ramp To | See Table 12 |
| Point 6 - Response | Drop List | Ramp To | See Table 12 |
| Point 7 - Response | Drop List | Ramp To | See Table 12 |
| Point 8 - Response | Drop List | Ramp To | See Table 12 |
| Point 9 - Response | Drop List | Ramp To | See Table 12 |
| Point 10 - Response | Drop List | Ramp To | See Table 12 |
| Point 0 - X Value | From X-Axis source minimum to Point 1 - X Value | X-Axis source minimum 0.000 | See Section 2.4 |
| Point 1 - X Value | From Point 0 - X Value to Point 2 - X Value | 0.500 | See Section 2.4 |
| Point 2 - X Value | From Point 1 - X Value to Point 3 - X Value | 1.000 | See Section 2.4 |
| Point 3 - X Value | From Point 2 - X Value to Point 4 - X Value | 1.500 | See Section 2.4 |
| Point 4 - X Value | From Point 3 - X Value to Point 5 - X Value source | 2.000 | See Section 2.4 |
| Point 5 - X Value | From Point 4 - X Value to Point 6 - X Value | 2.500 | See Section 2.4 |
| Point 6 - X Value | From Point 5 - X Value to Point 7 - X Value | 3.000 | See Section 2.4 |
| Point 7 - X Value | From Point 6 - X Value to Point 8 - X Value | 3.500 | See Section 2.4 |
| Point 8 - X Value | From Point 7 - X Value to Point 9 - X Value | 4.000 | See Section 2.4 |
| Point 9 - X Value | From Point 8 - X Value to Point 10 - X Value | 4.500 | See Section 2.4 |
| Point 10 - X Value | From Point 9 - X Value to X-Axis source maximum | X-Axis source maximum 5.000 | See Section 2.4 |
| Point 0 - Y Value | -10 ⁶ to 10 ⁶ | 0.000 | |
| Point 1 - Y Value | -10 ⁶ to 10 ⁶ | 10.000 | |
| Point 2 - Y Value | -10 ⁶ to 10 ⁶ | 20.000 | |
| Point 3 - Y Value | -10 ⁶ to 10 ⁶ | 30.000 | |
| Point 4 - Y Value | -10 ⁶ to 10 ⁶ | 40.000 | |
| Point 5 - Y Value | -10 ⁶ to 10 ⁶ | 50.000 | |
| Point 6 - Y Value | -10 ⁶ to 10 ⁶ | 60.000 | |
| Point 7 - Y Value | -10 ⁶ to 10 ⁶ | 70.000 | |
| Point 8 - Y Value | -10 ⁶ to 10 ⁶ | 80.000 | |
| Point 9 - Y Value | -10 ⁶ to 10 ⁶ | 90.000 | |
| Point 10 - Value | -10 ⁶ to 10 ⁶ | 100.000 | |

Table 30 – Lookup Table Setpoints

5.13. Programmable Logic

The Programmable Logic function block is defined in Section 2.5. Please refer there for detailed information about how all these setpoints are used. **“Programmable Logic Enabled”** is *‘False’* by default. To enable Logic set **“Programmable Logic Enabled”** to *‘True’* and select appropriate **“Argument Source”**.

| Setpoint Name | Value | Comment |
|---------------------------------------------|-------|---------------------------------------------------------|
| SP Programmable Logic Enabled | 1 | True |
| SP Table 1 - Lookup Table Block Number | 1 | Lookup Table 1 |
| SP Table 1 - Conditions Logical Operator | 1 | Cnd1 And Cnd2 And Cnd3 |
| SP Table 1 - Condition 1, Argument 1 Source | 0 | Control Not Used |
| SP Table 1 - Condition 1, Argument 1 Number | | Parameter not used with current Control Source selected |
| SP Table 1 - Condition 1, Operator | | Parameter not used with current Control Source selected |
| SP Table 1 - Condition 1, Argument 2 Source | 0 | Control Not Used |
| SP Table 1 - Condition 1, Argument 2 Number | | Parameter not used with current Control Source selected |
| SP Table 1 - Condition 2, Argument 1 Source | 0 | Control Not Used |
| SP Table 1 - Condition 2, Argument 1 Number | | Parameter not used with current Control Source selected |
| SP Table 1 - Condition 2, Operator | | Parameter not used with current Control Source selected |
| SP Table 1 - Condition 2, Argument 2 Source | 0 | Control Not Used |
| SP Table 1 - Condition 2, Argument 2 Number | | Parameter not used with current Control Source selected |
| SP Table 1 - Condition 3, Argument 1 Source | 0 | Control Not Used |
| SP Table 1 - Condition 3, Argument 1 Number | | Parameter not used with current Control Source selected |
| SP Table 1 - Condition 3, Operator | | Parameter not used with current Control Source selected |
| SP Table 1 - Condition 3, Argument 2 Source | 0 | Control Not Used |
| SP Table 1 - Condition 3, Argument 2 Number | | Parameter not used with current Control Source selected |
| SP Table 2 - Lookup Table Block Number | 2 | Lookup Table 2 |
| SP Table 2 - Conditions Logical Operator | 1 | Cnd1 And Cnd2 And Cnd3 |
| SP Table 2 - Condition 1, Argument 1 Source | 0 | Control Not Used |
| SP Table 2 - Condition 1, Argument 1 Number | | Parameter not used with current Control Source selected |
| SP Table 2 - Condition 1, Operator | | Parameter not used with current Control Source selected |
| SP Table 2 - Condition 1, Argument 2 Source | 0 | Control Not Used |
| SP Table 2 - Condition 1, Argument 2 Number | | Parameter not used with current Control Source selected |
| SP Table 2 - Condition 2, Argument 1 Source | 0 | Control Not Used |
| SP Table 2 - Condition 2, Argument 1 Number | | Parameter not used with current Control Source selected |
| SP Table 2 - Condition 2, Operator | | Parameter not used with current Control Source selected |
| SP Table 2 - Condition 2, Argument 2 Source | 0 | Control Not Used |
| SP Table 2 - Condition 2, Argument 2 Number | | Parameter not used with current Control Source selected |
| SP Table 2 - Condition 3, Argument 1 Source | 0 | Control Not Used |
| SP Table 2 - Condition 3, Argument 1 Number | | Parameter not used with current Control Source selected |
| SP Table 2 - Condition 3, Operator | | Parameter not used with current Control Source selected |
| SP Table 2 - Condition 3, Argument 2 Source | 0 | Control Not Used |
| SP Table 2 - Condition 3, Argument 2 Number | | Parameter not used with current Control Source selected |
| SP Table 3 - Lookup Table Block Number | 3 | Lookup Table 3 |
| SP Table 3 - Conditions Logical Operator | 1 | Cnd1 And Cnd2 And Cnd3 |
| SP Table 3 - Condition 1, Argument 1 Source | 0 | Control Not Used |
| SP Table 3 - Condition 1, Argument 1 Number | | Parameter not used with current Control Source selected |

Figure 16 – Screen Capture of Programmable Logic Setpoints

Setpoint ranges and default values for Programmable Logic Blocs are listed in Table 31. Only “**Table1**” setpoint are listed, because other “**TableX**” setpoints are similar, except for the default value of the “**Lookup Table Block Number**” setpoint, which is X for “**TableX**”.

| Name | Range | Default | Notes |
|----------------------------------------|---------------------------|------------------|--------------|
| Programmable Logic Enabled | Drop List | False | |
| Table1 - Lookup Table Block Number | 1 to 4 | Look up Table 1 | |
| Table1 - Conditions Logical Operation | Drop List | Default Table | See Table 14 |
| Table1 - Condition1, Argument 1 Source | Drop List | Control Not Used | See Table 19 |
| Table1 - Condition1, Argument 1 Number | Depends on control source | 1 | See Table 19 |
| Table1 - Condition1, Operator | Drop List | =, Equal | See Table 13 |
| Table1 - Condition1, Argument 2 Source | Drop List | Control Not Used | See Table 19 |
| Table1 - Condition1, Argument 2 Number | Depends on control source | 1 | See Table 19 |
| Table1 - Condition2, Argument 1 Source | Drop List | Control Not Used | See Table 19 |
| Table1 - Condition2, Argument 1 Number | Depends on control source | 1 | See Table 19 |
| Table1 - Condition2, Operator | Drop List | =, Equal | See Table 13 |
| Table1 - Condition2, Argument 2 Source | Drop List | Control Not Used | See Table 19 |
| Table1 - Condition2, Argument 2 Number | Depends on control source | 1 | See Table 19 |
| Table1 - Condition3, Argument 1 Source | Drop List | Control Not Used | See Table 19 |
| Table1 - Condition3, Argument 1 Number | Depends on control source | 1 | See Table 19 |
| Table1 - Condition3, Operator | Drop List | =, Equal | See Table 13 |
| Table1 - Condition3, Argument 2 Source | Drop List | Control Not Used | See Table 19 |
| Table1 - Condition3, Argument 2 Number | Depends on control source | 1 | See Table 19 |

Table 31 – Programmable Logic Setpoints

5.14. Math Function Block

The Math Function Block is defined in Section 2.6. Please refer there for detailed information about how all these setpoints are used. **“Math Function Enabled”** is ‘False’ by default. To enable a Math Function Block, set **“Math Function Enabled”** to ‘True’ and select appropriate **“Input Source”**.

| Setpoint Name | Value | Comment |
|---------------------------------------------------------------|---------|---------------------------------------------------------|
| SP Math Function Enabled | 1 | True |
| SP Function 1 Input A Source | 0 | Control Not Used |
| SP Function 1 Input A Number | | Parameter not used with current Control Source selected |
| SP Function 1 Input A Minimum | | Parameter not used with current Control Source selected |
| SP Function 1 Input A Maximum | | Parameter not used with current Control Source selected |
| SP Function 1 Input A Scaler | | Parameter not used with current Control Source selected |
| SP Function 1 Input B Source | 0 | Control Not Used |
| SP Function 1 Input B Number | | Parameter not used with current Control Source selected |
| SP Function 1 Input B Minimum | | Parameter not used with current Control Source selected |
| SP Function 1 Input B Maximum | | Parameter not used with current Control Source selected |
| SP Function 1 Input B Scaler | | Parameter not used with current Control Source selected |
| SP Math Function 1 Operation | | Parameter not used with current Control Source selected |
| SP Function 2 Input B Source | 0 | Control Not Used |
| SP Function 2 Input B Number | | Parameter not used with current Control Source selected |
| SP Function 2 Input B Minimum | | Parameter not used with current Control Source selected |
| SP Function 2 Input B Maximum | | Parameter not used with current Control Source selected |
| SP Function 2 Input B Scaler | | Parameter not used with current Control Source selected |
| SP Math Function 2 Operation (Input A = Result of Function 1) | | Parameter not used with current Control Source selected |
| SP Function 3 Input B Source | 0 | Control Not Used |
| SP Function 3 Input B Number | | Parameter not used with current Control Source selected |
| SP Function 3 Input B Minimum | | Parameter not used with current Control Source selected |
| SP Function 3 Input B Maximum | | Parameter not used with current Control Source selected |
| SP Function 3 Input B Scaler | | Parameter not used with current Control Source selected |
| SP Math Function 3 Operation (Input A = Result of Function 2) | | Parameter not used with current Control Source selected |
| SP Function 4 Input B Source | 0 | Control Not Used |
| SP Function 4 Input B Number | | Parameter not used with current Control Source selected |
| SP Function 4 Input B Minimum | | Parameter not used with current Control Source selected |
| SP Function 4 Input B Maximum | | Parameter not used with current Control Source selected |
| SP Function 4 Input B Scaler | | Parameter not used with current Control Source selected |
| SP Math Function 4 Operation (Input A = Result of Function 3) | | Parameter not used with current Control Source selected |
| SP Math Output Minimum Range | 0.00 | |
| SP Math Output Maximum Range | 1000.00 | |

Figure 17 – Screen Capture of Math Function Block Setpoints

| Name | Range | Default | Notes |
|----------------------------|-------------------------------------|-----------------------------|--------------|
| Math Function Enabled | Drop List | False | |
| Function 1 Input A Source | Drop List | Control not used | See Table 19 |
| Function 1 Input A Number | Depends on control source | 1 | See Table 19 |
| Function 1 Input A Minimum | -10 ⁶ to 10 ⁶ | 0.0 | |
| Function 1 Input A Maximum | -10 ⁶ to 10 ⁶ | 100.0 | |
| Function 1 Input A Scaler | -1.00 to 1.00 | 1.00 | |
| Function 1 Input B Source | Drop List | Control not used | See Table 19 |
| Function 1 Input B Number | Depends on control source | 1 | See Table 19 |
| Function 1 Input B Minimum | -10 ⁶ to 10 ⁶ | 0.0 | |
| Function 1 Input B Maximum | -10 ⁶ to 10 ⁶ | 100.0 | |
| Function 1 Input B Scaler | -1.00 to 1.00 | 1.00 | |
| Math Function 1 Operation | Drop List | =, True when InA Equals InB | See Table 15 |
| Function 2 Input B Source | Drop List | Control not used | See Table 19 |
| Function 2 Input B Number | Depends on control source | 1 | See Table 19 |
| Function 2 Input B Minimum | -10 ⁶ to 10 ⁶ | 0.0 | |
| Function 2 Input B Maximum | -10 ⁶ to 10 ⁶ | 100.0 | |
| Function 2 Input B Scaler | -1.00 to 1.00 | 1.00 | |
| Math Function 3 Operation | Drop List | =, True when InA Equals InB | See Table 15 |
| Function 3 Input B Source | Drop List | Control not used | See Table 19 |
| Function 3 Input B Number | Depends on control source | 1 | See Table 19 |
| Function 3 Input B Minimum | -10 ⁶ to 10 ⁶ | 0.0 | |
| Function 3 Input B Maximum | -10 ⁶ to 10 ⁶ | 100.0 | |
| Function 3 Input B Scaler | -1.00 to 1.00 | 1.00 | |
| Math Function 3 Operation | Drop List | =, True when InA Equals InB | See Table 15 |
| Function 4 Input B Source | Drop List | Control not used | See Table 19 |
| Function 4 Input B Number | Depends on control source | 1 | See Table 19 |
| Function 4 Input B Minimum | -10 ⁶ to 10 ⁶ | 0.0 | |
| Function 4 Input B Maximum | -10 ⁶ to 10 ⁶ | 100.0 | |
| Function 4 Input B Scaler | -1.00 to 1.00 | 1.00 | |
| Math Function 4 Operation | Drop List | =, True when InA Equals InB | See Table 15 |
| Math Output Minimum Range | -10 ⁶ to 10 ⁶ | 0.0 | |
| Math Output Maximum Range | -10 ⁶ to 10 ⁶ | 100.0 | |

Table 32 – Math Function Setpoints

5.15. CAN Transmit Setpoints

CAN Transmit Message Function Block is presented in section 2.9. Please refer there for detailed information how these setpoints are used. **“Transmit Repetition Rate”** is 0ms by default, thus no message will be sent.

| Setpoint Name | Value | Comment |
|------------------------------------------------|------------|-------------------------------------|
| SP Transmit PGN | 0xFF00 | Transmit PGN: 65280 |
| SP Transmit Repetition Rate | 100 | ms |
| SP Transmit Message Priority | 6 | |
| SP Destination Address (PDU1) | 0 | Destination ECU Address: 0x0 |
| SP Signal 1 Data Source | 2 | Universal/Digital Input Measured |
| SP Signal 1 Data Number | 1 | Universal/Digital Input Measured #1 |
| SP Signal 1 Transmit Data Type | 2 | CAN signal continuous |
| SP Signal 1 Transmit Data Width | 16 | |
| SP Signal 1 Transmit Data Index in Array (LSB) | 0 | 1st Byte Position |
| SP Signal 1 Transmit Bit Index in Byte (LSB) | 0 | 1st Bit Position |
| SP Signal 1 Transmit Data Resolution | 0.0010000 | |
| SP Signal 1 Transmit Data Offset | 0.0000000 | |
| SP Signal 1 Transmit Data Minimum | 0.0000000 | |
| SP Signal 1 Transmit Data Maximum | 10.0000000 | |
| SP Signal 2 Data Source | 2 | Universal/Digital Input Measured |
| SP Signal 2 Data Number | 2 | Universal/Digital Input Measured #2 |
| SP Signal 2 Transmit Data Type | 2 | CAN signal continuous |
| SP Signal 2 Transmit Data Width | 16 | |
| SP Signal 2 Transmit Data Index in Array (LSB) | 2 | 3rd Byte Position |
| SP Signal 2 Transmit Bit Index in Byte (LSB) | 0 | 1st Bit Position |
| SP Signal 2 Transmit Data Resolution | 0.0010000 | |
| SP Signal 2 Transmit Data Offset | 0.0000000 | |
| SP Signal 2 Transmit Data Minimum | 0.0000000 | |
| SP Signal 2 Transmit Data Maximum | 10.0000000 | |
| SP Signal 3 Data Source | 2 | Universal/Digital Input Measured |
| SP Signal 3 Data Number | 3 | Universal/Digital Input Measured #3 |
| SP Signal 3 Transmit Data Type | 2 | CAN signal continuous |
| SP Signal 3 Transmit Data Width | 16 | |
| SP Signal 3 Transmit Data Index in Array (LSB) | 4 | 5th Byte Position |
| SP Signal 3 Transmit Bit Index in Byte (LSB) | 0 | 1st Bit Position |
| SP Signal 3 Transmit Data Resolution | 0.0010000 | |
| SP Signal 3 Transmit Data Offset | 0.0000000 | |
| SP Signal 3 Transmit Data Minimum | 0.0000000 | |
| SP Signal 3 Transmit Data Maximum | 10.0000000 | |
| SP Signal 4 Data Source | 2 | Universal/Digital Input Measured |
| SP Signal 4 Data Number | 4 | Universal/Digital Input Measured #4 |
| SP Signal 4 Transmit Data Type | 2 | CAN signal continuous |
| SP Signal 4 Transmit Data Width | 16 | |
| SP Signal 4 Transmit Data Index in Array (LSB) | 6 | 7th Byte Position |

Figure 18 – Screen Capture of CAN Transmit Message Setpoints

| Name | Range | Default | Notes |
|---------------------------------------|---------------------|--------------------|-------------------------------------------------------|
| Transmit PGN | 0xff00 ... 0xffff | Different for each | See Section Error! Reference source not found. |
| Transmit Repetition Rate | 0 ... 65000 ms | 0ms | 0ms disables transmit |
| Transmit Message Priority | 0...7 | 6 | Proprietary B Priority |
| Destination Address | 0...255 | 255 | Not used by default |
| Signal 1 Control Source | Drop List | Different for each | See Table 19 |
| Signal 1 Control Number | Drop List | Different for each | See Table 19 |
| Signal 1 Transmit Data Type | Drop List | 0 | |
| Signal 1 Transmit Data Width | 1-32 | 1 | |
| Signal 1 Transmit Data Index in Array | 0-7 | 2 | |
| Signal 1 Transmit Bit Index In Byte | 0-7 | 0 | |
| Signal 1 Transmit Data Resolution | -100000.0 to 100000 | 0.001 | |
| Signal 1 Transmit Data Offset | -10000 to 10000 | 0.0 | |
| Signal 2 Control Source | Drop List | Signal undefined | See Table 19 |
| Signal 2 Control Number | Drop List | Signal undefined | See Table 19 |
| Signal 2 Transmit Data Type | Drop List | 0 | |
| Signal 2 Transmit Data Width | 1-32 | 1 | |
| Signal 2 Transmit Data Index in Array | 0-7 | 0 | |
| Signal 2 Transmit Bit Index In Byte | 0-7 | 0 | |
| Signal 2 Transmit Data Resolution | -100000.0 to 100000 | 0.001 | |
| Signal 2 Transmit Data Offset | -10000 to 10000 | 0.0 | |
| Signal 3 Control Source | Drop List | Signal undefined | See Table 19 |
| Signal 3 Control Number | Drop List | Signal undefined | See Table 19 |
| Signal 3 Transmit Data Type | Drop List | 0 | |
| Signal 3 Transmit Data Width | 1-32 | 1 | |
| Signal 3 Transmit Data Index in Array | 0-7 | 0 | |
| Signal 3 Transmit Bit Index In Byte | 0-7 | 0 | |
| Signal 3 Transmit Data Resolution | -100000.0 to 100000 | 0.001 | |
| Signal 3 Transmit Data Offset | -10000 to 10000 | 0.0 | |
| Signal 4 Control Source | Drop List | Signal undefined | See Table 19 |
| Signal 4 Control Number | Drop List | Signal undefined | See Table 19 |
| Signal 4 Transmit Data Type | Drop List | 0 | |
| Signal 4 Transmit Data Width | 1-32 | 1 | |
| Signal 4 Transmit Data Index in Array | 0-7 | 0 | |
| Signal 4 Transmit Bit Index In Byte | 0-7 | 0 | |
| Signal 4 Transmit Data Resolution | -100000.0 to 100000 | 0.001 | |
| Signal 4 Transmit Data Offset | -10000 to 10000 | 0.0 | |

Table 33 – CAN Transmit Message Setpoints

5.16. CAN Receive Setpoints

The Math Function Block is defined in Section 2.10. Please refer there for detailed information about how these setpoints are used. “**Receive Message Timeout**” is set to 0ms by default. To enable Receive message set “**Receive Message Timeout**” that differs from zero.

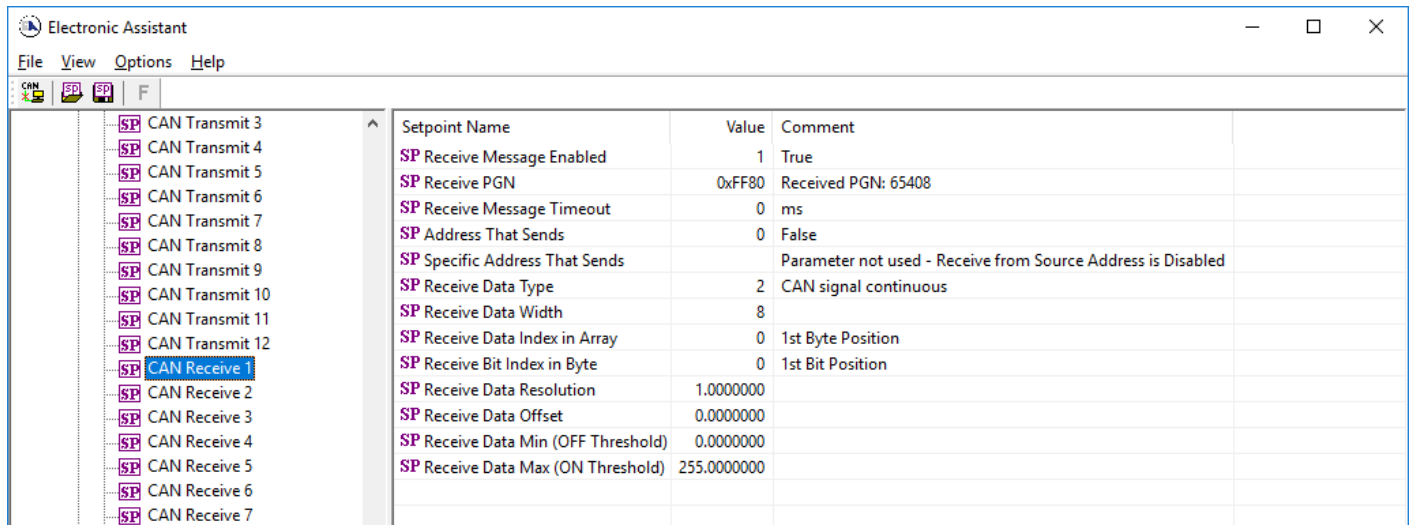

Figure 19 – Screen Capture of CAN Receive Message Setpoints

| Name | Range | Default | Notes |
|------------------------------------|---------------------|-----------------------|-------|
| Received Message Enabled | Drop List | False | |
| Received PGN | 0 to 65536 | Different for each | |
| Received Message Timeout | 0 to 60 000 ms | 0ms | |
| Specific Address That Sends | Drop List | False | |
| Address That Sends | 0 to 255 | 254 (0xFE, Null Addr) | |
| Receive Data Type | Drop List | 0 | |
| Receive Data Width | 1-32 | 1 | |
| Receive Data Index in Array | 0-7 | 0 | |
| Receive Transmit Bit Index In Byte | 0-7 | 0 | |
| Receive Transmit Data Resolution | -100000.0 to 100000 | 0.001 | |
| Receive Transmit Data Offset | -10000 to 10000 | 0.0 | |
| Receive Data Min (Off Threshold) | -1000000 to Max | 0.0 | |
| Receive Data Max (On Threshold) | -100000 to 100000 | 2.0 | |

Table 34 – CAN Receive Setpoints

5.17. DTC React

The DTC React Function Block is defined in Section 2.11. Please refer there for detailed information about how these setpoints are used.

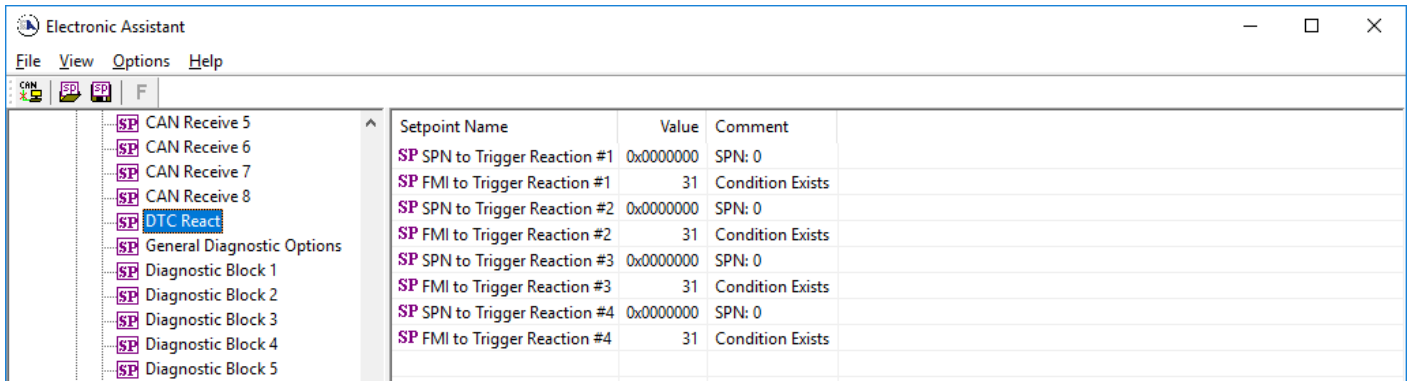

Figure 20 – Screen Capture of DTC React Setpoints

| Name | Range | Default | Notes |
|----------------------------|-------------|----------------------|---------------------------------------------|
| SPN to Trigger Reaction #1 | 0 to 524287 | 0 | 0 is an illegal value, and disables the DTC |
| FMI to Trigger Reaction #X | Drop List | 31, Condition Exists | Supports all FMIs in the J1939 standard |

Table 35 – DTC React Setpoints

5.18. General Diagnostics Options

These setpoints control the shutdown of the ECU in case of a power supply or CPU temperature related errors. Refer to section 2.8 for more info.

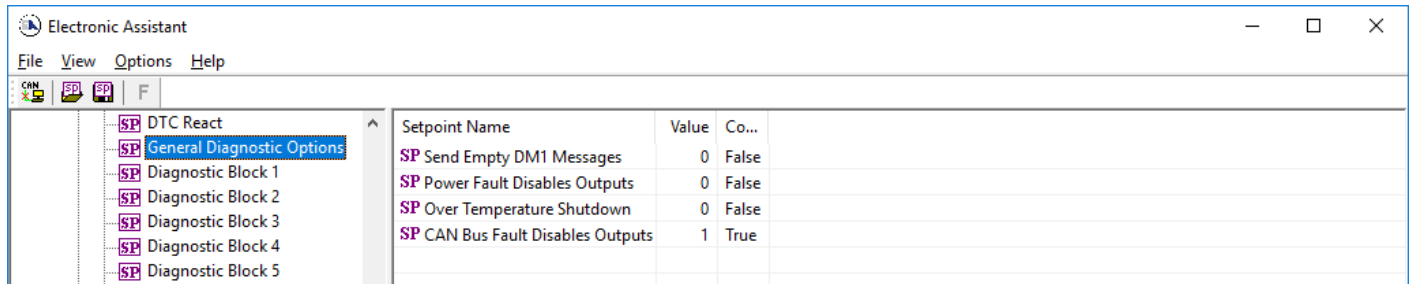

Figure 21 – Screen Capture of General Diagnostics Options Setpoints

| Name | Range | Default | Notes |
|--------------------------------------|-----------|---------|-------|
| Power Fault Disables Motor Driving | Drop List | 0 | |
| Over Temperature Shutdown | Drop List | 0 | |
| CAN Bus Fault Disables Motor Driving | Drop List | 0 | |

Table 36 – General Diagnostics Options Setpoints

5.19. Diagnostics Blocks

There are 12 Diagnostics blocks that can be configured to monitor various parameters of the Controller. The Diagnostic Function Block is defined in section 2.8. Please refer there for detailed information how these setpoints are used.

| Setpoint Name | Value | Comment |
|----------------------------------------------------|-----------|---------------------------------------------------------------|
| SP Fault Detection is Enabled | 1 | True |
| SP Function Type to Monitor | 11 | Power Supply Measured |
| SP Function Parameter to Monitor | 1 | Power Supply Measured |
| SP Enable Source | 0 | Control Not Used |
| SP Enable Number | | Parameter not used with current Enable Source selected |
| SP Enable Response | | Parameter not used with current Enable Source selected |
| SP Fault Detection Type | 4 | Double Threshold Min and Max Error |
| SP Maximum Value for Diagnostic Data | 54.00 | |
| SP Minimum Value for Diagnostic Data | 0.00 | |
| SP Use Hysteresis When Defining Thresholds | 1 | True |
| SP Hysteresis | 1.00 | |
| SP Event Cleared Only by DM11 | 0 | False |
| SP Set Limit for MAXIMUM SHUTDOWN | 36.00 | |
| SP Clear Limit for MAXIMUM SHUTDOWN | | Parameter not used - Hysteresis used when defining thresholds |
| SP Set Limit for MAXIMUM WARNING | 32.00 | |
| SP Clear Limit for MAXIMUM WARNING | | Parameter not used - Hysteresis used when defining thresholds |
| SP Clear Limit for MINIMUM WARNING | | Parameter not used - Hysteresis used when defining thresholds |
| SP Set Limit for MINIMUM WARNING | 10.00 | |
| SP Clear Limit for MINIMUM SHUTDOWN | | Parameter not used - Hysteresis used when defining thresholds |
| SP Set Limit for MINIMUM SHUTDOWN | 8.00 | |
| SP MAXIMUM SHUTDOWN, Event Generates a DTC in DM1 | 1 | True |
| SP MAXIMUM SHUTDOWN, Lamp Set by Event | 1 | Amber,Warning |
| SP MAXIMUM SHUTDOWN, SPN for Event | 0x0000064 | SPN: 100 |
| SP MAXIMUM SHUTDOWN, FMI for Event | 3 | Voltage Above Normal, Or Shorted To High Source |
| SP MAXIMUM SHUTDOWN, Delay Before Event is Flagged | 1000 | ms |
| SP MAXIMUM WARNING, Event Generates a DTC in DM1 | 1 | True |
| SP MAXIMUM WARNING, Lamp Set by Event | 1 | Amber,Warning |
| SP MAXIMUM WARNING, SPN for Event | 0x00000C8 | SPN: 200 |
| SP MAXIMUM WARNING, FMI for Event | 3 | Voltage Above Normal, Or Shorted To High Source |
| SP MAXIMUM WARNING, Delay Before Event is Flagged | 1000 | ms |
| SP MINIMUM WARNING, Event Generates a DTC in DM1 | 1 | True |
| SP MINIMUM WARNING, Lamp Set by Event | 1 | Amber,Warning |
| SP MINIMUM WARNING, SPN for Event | 0x000012C | SPN: 300 |
| SP MINIMUM WARNING, FMI for Event | 4 | Voltage Below Normal, Or Shorted To Low Source |
| SP MINIMUM WARNING, Delay Before Event is Flagged | 1000 | ms |
| SP MINIMUM SHUTDOWN, Event Generates a DTC in DM1 | 1 | True |
| SP MINIMUM SHUTDOWN, Lamp Set by Event | 1 | Amber,Warning |
| SP MINIMUM SHUTDOWN, SPN for Event | 0x0000190 | SPN: 400 |
| SP MINIMUM SHUTDOWN, FMI for Event | 4 | Voltage Below Normal, Or Shorted To Low Source |
| SP MINIMUM SHUTDOWN, Delay Before Event is Flagged | 1000 | ms |

Figure 22 – Screen Capture of Diagnostic Block Setpoints

| Name | Range | Default | Notes |
|-------------------------------------------------|--------------------------------------------------------------------------|-------------------------|--------------------------------------------------------------------------------------------|
| Fault Detection is Enabled | Drop List | False | |
| Function Type to Monitor | Drop List | 0 – Control not used | |
| Function parameter to Monitor | Drop List | 0 – No selection | |
| Fault Detection Type | Drop List | 1 – Min and Max Error | See section 2.8 |
| Maximum Value for Diagnostic Data | Minimum Value for Diagnostic Data ... 4.28e ⁹ | 5.0 | |
| Minimum Value for Diagnostic Data | 0.0 ... Maximum Value for Diagnostic Data | 0.0 | |
| Use Hysteresis When Defining Thresholds | Drop List | False | |
| Hysteresis | 0.0 ... Maximum Value for Diagnostic Data | 0.0 | |
| Event Cleared only by DM11 | Drop List | False | |
| Set Limit for MAXIMUM SHUTDOWN | Minimum Value for Diagnostic Data ... Maximum Value for Diagnostics Data | 4.8 | |
| Clear Limit for MAXIMUM SHUTDOWN | Minimum Value for Diagnostic Data ... Maximum Value for Diagnostics Data | 4.6 | |
| Set Limit for MAXIMUM WARNING | Minimum Value for Diagnostic Data ... Maximum Value for Diagnostics Data | 0.0 | |
| Clear Limit for MAXIMUM WARNING | Minimum Value for Diagnostic Data ... Maximum Value for Diagnostics Data | 0.0 | |
| Clear Limit for MINIMUM WARNING | Minimum Value for Diagnostic Data ... Maximum Value for Diagnostics Data | 0.0 | |
| Set Limit for MINIMUM WARNING | Minimum Value for Diagnostic Data ... Maximum Value for Diagnostics Data | 0.0 | |
| Clear Limit for MINIMUM SHUTDOWN | Minimum Value for Diagnostic Data ... Maximum Value for Diagnostics Data | 0.4 | |
| Set Limit for MINIMUM SHUTDOWN | Minimum Value for Diagnostic Data ... Maximum Value for Diagnostics Data | 0.2 | |
| MAXIMUM SHUTDOWN, Event Generates a DTC in DM1 | Drop List | True | |
| MAXIMUM SHUTDOWN, Lamp Set by Event | Drop List | 0 – Protect | See Table 16 |
| MAXIMUM SHUTDOWN, SPN for Event | 0...524287 | 520448 (\$7F100) | It is the user's responsibility to select an SPN that will not violate the J1939 standard. |
| MAXIMUM SHUTDOWN, FMI for Event | Drop List | 3, Voltage Above Normal | See Table 17 |
| MAXIMUM SHUTDOWN, Delay Before Event is Flagged | 0...60000 ms | 1000 | |
| MAXIMUM WARNING, Event Generates a DTC in DM1 | Drop List | True | |
| MAXIMUM WARNING, Lamp Set by Event | Drop List | 0 – Protect | See Table 16 |
| MAXIMUM WARNING, SPN for Event | 0...524287 | 520704 (\$7F200) | It is the user's responsibility to select an SPN that will not violate the J1939 standard. |
| MAXIMUM WARNING, FMI for Event | Drop List | 3, Voltage Above Normal | See Table 17 |
| MAXIMUM WARNING, Delay Before Event is Flagged | 0...60000 ms | 1000 | |
| MINIMUM WARNING, Event Generates a DTC in DM1 | Drop List | True | |
| MINIMUM WARNING, Lamp Set by Event | Drop List | 0 – Protect | See Table 16 |
| MAXIMUM WARNING, SPN for Event | 0...524287 | 520960 (\$7F300) | It is the user's responsibility to select an SPN that will not violate the J1939 standard. |
| MINIMUM WARNING, FMI for Event | Drop List | 4, Voltage Below Normal | See Table 17 |

| | | | |
|-------------------------------------------------|--------------|-------------------------|--------------------------------------------------------------------------------------------|
| MINIMUM WARNING, Delay Before Event is Flagged | 0...60000 ms | 1000 | |
| MINIMUM SHUTDOWN, Event Generates a DTC in DM1 | Drop List | True | |
| MINIMUM SHUTDOWN, Lamp Set by Event | Drop List | Amber Warning | See Table 16 |
| MINIMUM SHUTDOWN, SPN for Event | 0...524287 | 521216 (\$7F400) | It is the user's responsibility to select an SPN that will not violate the J1939 standard. |
| MINIMUM SHUTDOWN, FMI for Event | Drop List | 4, Voltage Below Normal | See Table 17 |
| MINIMUM SHUTDOWN, Delay Before Event is Flagged | 0...60000 ms | 1000 | |

Table 37 – Diagnostic Block Setpoints

6. Reflashing over CAN with EA Bootloader

The AX030210 can be upgraded with new application firmware using the **Bootloader Information** section. This section details the simple step-by-step instructions to upload new firmware provided by Axiomatic onto the unit via CAN, without requiring it to be disconnected from the J1939 network.

Note: To upgrade the firmware use Electronic Assistant ®  V5.13.98.0 or higher.

1. When EA first connects to the ECU, the **Bootloader Information** section will display the following information.

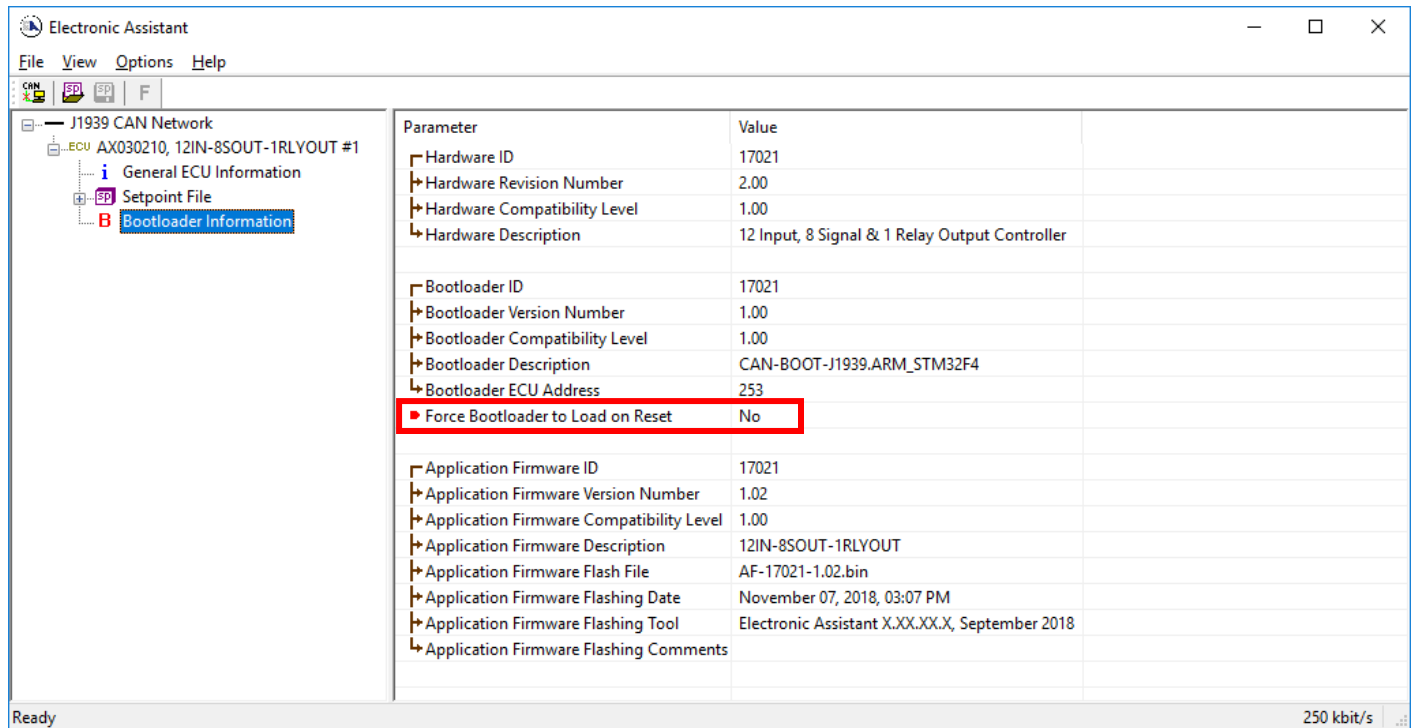

2. To use the bootloader to upgrade the firm-ware running on the ECU, change the variable “**Force Bootloader To Load on Reset**” to Yes.

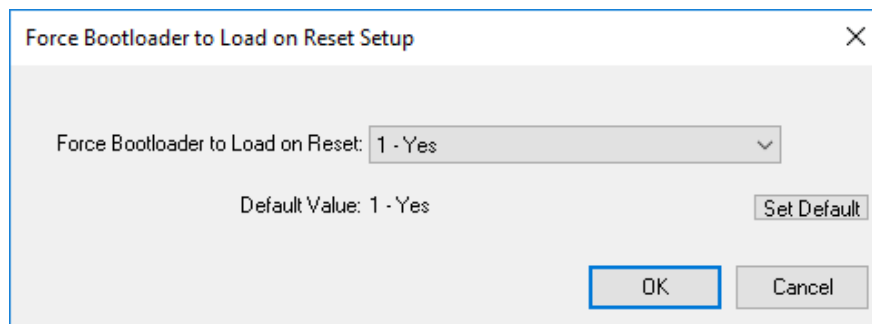

3. When the prompt box asks if you want to reset the ECU, select Yes.

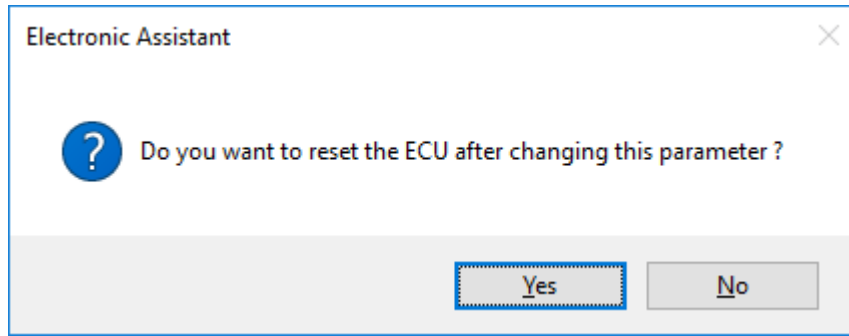

4. Upon reset, the ECU will no longer show up on the J1939 network as an AX030210 but rather as **J1939 Bootloader #1**.

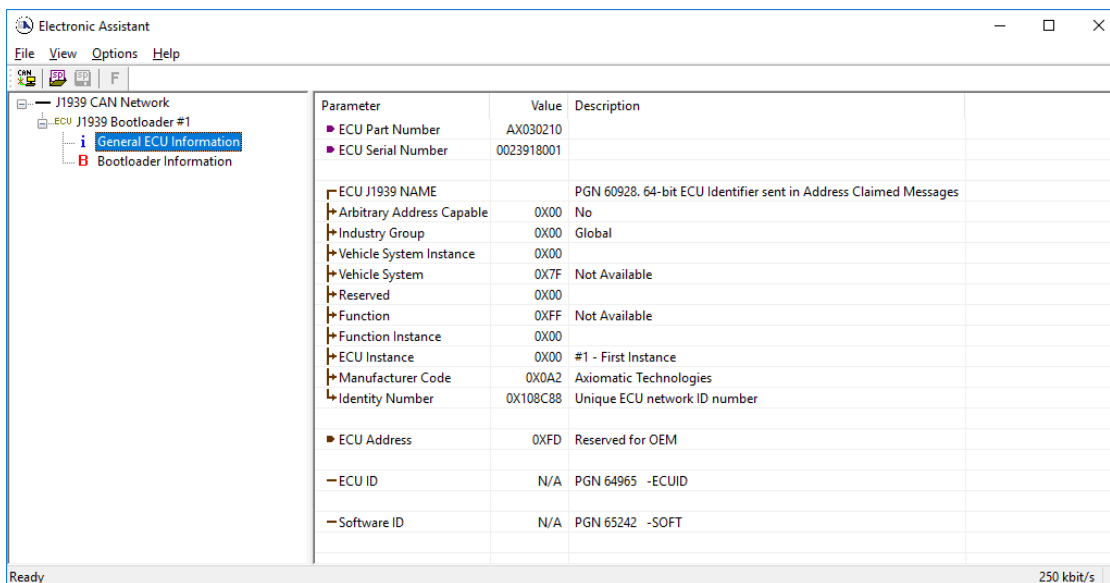
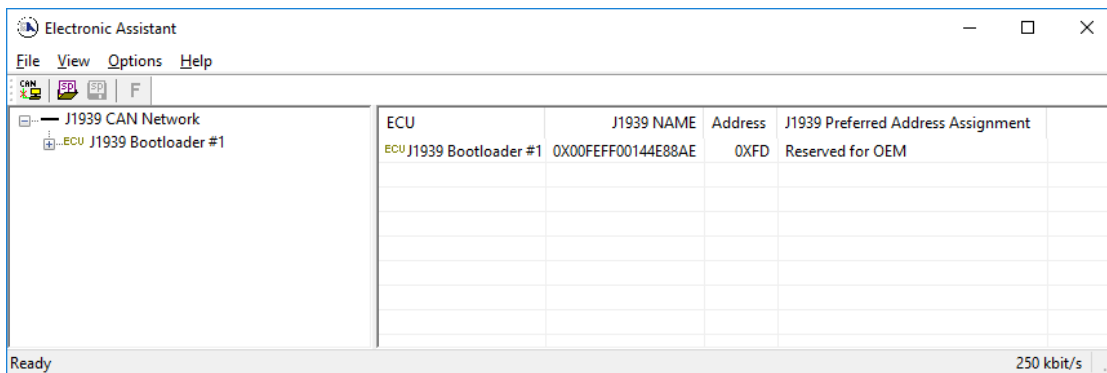

Note that the bootloader is NOT Arbitrary Address Capable. This means that if you want to have multiple bootloaders running simultaneously (not recommended) you would have to manually change the address for each one before activating the next, or there will be address conflicts. And only one ECU would show up as the bootloader. Once the 'active' bootloader returns to regular functionality, the other ECU(s) would have to be power cycled to re-activate the bootloader feature.

5. When the **Bootloader Information** section is selected, the same information is shown as when it was running the AX030210 firmware, but in this case the **F**lashing feature has been enabled.

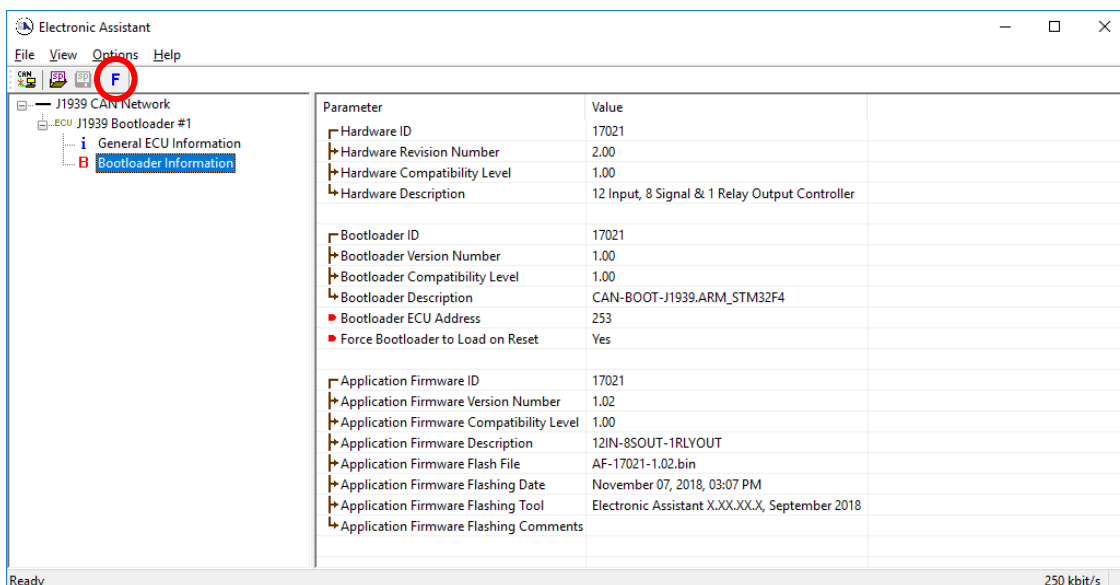

6. Select the **F**lashing button and navigate to where you had saved the **AF-17021-1.xx.bin** (or equivalent) file sent from Axiomatic. (Note: only binary (.bin) files can be flashed using the EA tool.)

7. Once the Flash Application Firmware window opens, you can enter comments such as “Firmware upgraded by [Name]” if you so desire. This is not required, and you can leave the field blank if you do not want to use it.

Note: You do not have to date/time-stamp the file, as this is done automatically by the EA tool when you upload the new firmware.

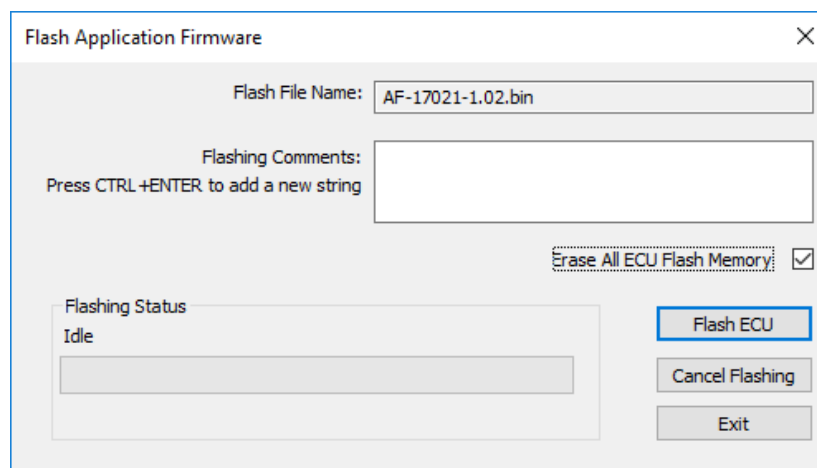

NOTE: It is good practice to tick the “Erase All ECU Flash Memory” box. Please note, that selecting this option will **erase ALL data stored in non-volatile flash**. It will also erase any configuration of the setpoints that might have been done to the ECU and reset all setpoints to their factory defaults. In case the controller contains custom settings, those settings need to be saved to PC before reflashing.

A progress bar will show how much of the firmware has been sent as the upload progresses. The more traffic there is on the J1939 network, the longer the upload process will take.

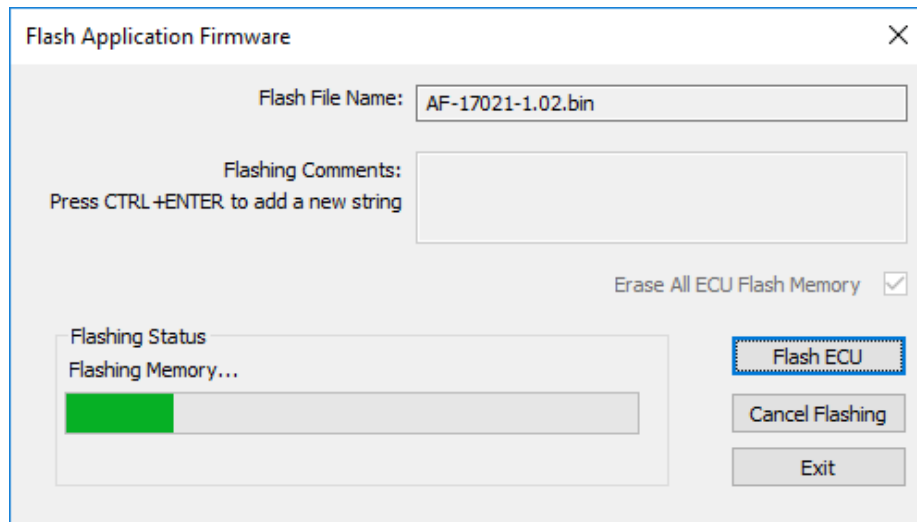

Once the firmware has finished uploading, a message will pop up indicating the successful operation. If you select to reset the ECU, the new version of the AX030210 application will start running, and the ECU will be identified as such by EA. Otherwise, the next time the ECU is power-cycled, the AX030210 application will run rather than the bootloader function.

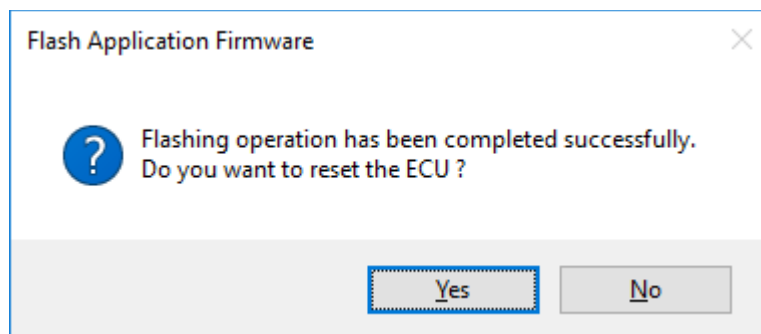

Note: If at any time during the upload the process is interrupted, the data is corrupted (bad checksum) or for any other reason the new firmware is not correct, i.e. bootloader detects that the file loaded was not designed to run on the hardware platform, the bad or corrupted application will not run. Rather, when the ECU is reset or power-cycled the **J1939 Bootloader** will continue to be the default application until valid firmware has been successfully uploaded into the unit.

APPENDIX A - TECHNICAL SPECIFICATION

Technical Specifications:

Specifications are indicative and subject to change. Actual performance will vary depending on the application and operating conditions. Users should satisfy themselves that the product is suitable for use in the intended application. All our products carry a limited warranty against defects in material and workmanship. Please refer to our Warranty, Application Approvals/Limitations and Return Materials Process as described on www.axiomatic.com/service.html.

Input Power

| | |
|------------------------------|------------------------------------------------------------------------------------------------------------------------------------------------------------------------------------------------------------------------------------------------------------------------------------------------------------------------------------------------------------------------------------------------------------------------------------------------------------------------------------------------------------------------------------------------------------------------------------------------------------------------------------------------|
| Power Supply Input - Nominal | <p>12, 24VDC nominal (8...36 VDC power supply range) Surge protection is provided.</p> <p>If batteries are used, an alternator or other battery-charging device is necessary to maintain a stable supply voltage. Central suppression of any surge events should be provided at the system level. The installation of the equipment must include overcurrent protection between the power source and the module by means of a series connection of properly rated fuses or circuit breakers. Input power switches must be arranged external to the Axiomatic Control Module.</p> <p>Power input wiring should be limited to 10 meters.</p> |
| Quiescent Current | <p>300 mA at 12 Vdc Typical 155 mA at 24 Vdc Typical Inrush does not exceed 500 mA.</p> |
| Protection | <p>Reverse polarity protection is provided. Power supply input section protects against transients, surges (per IEC 60533, Table 4) and short circuits and is isolated from inputs. Undervoltage protection is provided and hardware shuts down at 7.5Vdc. Over-voltage protection is provided, and hardware shuts down at 41Vdc.</p> |

Inputs

| | |
|--------------------------------------|------------------------------------------------------------------------------------------------------------------------------------------------------------------------------------------------------------------------------------------------------------------------------------------------------------------------------------------------------------------------------------------------------------------------|
| Universal Signal Inputs | Up to 10 inputs are selectable by the user. All inputs, except for frequency, are sampled every 1ms. The user can select the type of filter that is applied to the measured data, before it is transmitted to the bus. The available filters are: <ul style="list-style-type: none"> • Filter Type 0 = No Filter • Filter Type 1 = Moving Average • Filter Type 2 = Repeating Average |
| Universal Signal Input Configuration | Up to 10 inputs are available. <i>Refer to Table 38.0.</i> Each input can be configured for any one of the following options. <ul style="list-style-type: none"> • Disable input • 0...5VDC or 0...10VDC • 4...20mA or 0...20mA • Digital input • PWM signal • Pulse (Hz or RPM) • 16-bit Counter |
| Input Protections | All inputs are protected against short circuits to GND or +Vcc. |
| Resistive Input | One resistive type input 1 Ohm resolution +/- 1 % accuracy Self-calibrating in the range of 25 Ohms to 250 kOhms |
| Analog GND | 10 Analog GND connections are provided. The grounds are connected internally in the module. 1 Resistive Input GND connection is provided. |
| Voltage References | 2 +5V references (sourcing up to 100 mA) +/- 0.1% or 2 +10V references (sourcing up to 100 mA) +/-0.2% |
| Input Scan Rate | 1 mSec. |
| Digital Input | One Digital Input Active High or Active Low Configurable 10 kΩpullup or pulldown resistor |

Table 38.0 Description of Inputs to AX030210

| Input Type | Description |
|------------------------------|-------------------------------------------------------------------------------------------------------------------------------------------------------------------------------------------------------------------------------------------------------------------------------------------------------------------------------------------------------------------------------------------------------------------------------------------------------------------------------------------------------------------------|
| Analog Inputs | Up to 10 analog inputs are available. 0...5VDC or 0...10VDC 4...20mA or 0...20mA |
| Digital Inputs | Up to 10 digital inputs are available. The input accepted is active high or active low. Configurable 10 kΩpullup or pulldown resistor |
| PWM Signal Inputs | Up to 10 PWM inputs are available to interface to a PWM signal from an ECM, PLC, etc. PWM Signal Frequency: 0.50 – 10,000 Hz Amplitude: 5-12V PWM Duty Cycle: 0 to 100% |
| Pulse Inputs | Up to 10 pulse inputs are available. This input counts the number of pulses over the period of the measuring window setpoint and calculates the frequency of the pulses. NOTE: The difference between Frequency and Counter mode is that the Frequency mode measures the number of pulses that occur in the Measuring Window period and calculates frequency, while the counter gives the period of time (in milliseconds) it takes for the number of pulses in the Measuring Window to be read at the input. |
| 16-bit Counter Inputs | Up to ten 16-bit counter inputs are available. The input is configured to count pulses on the input until the value in the measuring window setpoint is reached. |
| Threshold Levels | For digital, PWM, pulse or counter inputs the voltage threshold levels are: <u>Input positive threshold (signal goes from low to high):</u> Min. 2.2V, typical 2.9V, max. 3.6V <u>Input negative threshold (signal goes from high to low):</u> Min. 1.2V, typical 1.7V, max. 2.3V |
| Input Accuracy | 0-5V: +/- 1% 0-10V: +/- 1% 0-20mA or 4-20 mA: +/- 1% PWM, single channel: +/- 1% Frequency/RPM, single channel: +/- 1% 16-bit counter, single channel: +/- 3 mSec (@50 Hz) |
| Input Resolution | 0-5V or 0-10V: 1 mV 0-20mA or 4-20 mA: 1μA |
| Input Impedance | Voltage 1 MOhm Current 124Ω PWM, frequency, 16-bit counter 1 MOhm |

Outputs

| Analog Outputs | <p>8 Analog outputs 16-bit Digital to Analog User selectable (0-5V, 0-10V, +/-5V, +/-10V, 0-20 mA, 4-20 mA)</p> <p>Each analog output can be configured for one of the following options, and the properties and behavior of the output in each mode is described below in Table 2.0.</p> <table border="1"> <thead> <tr> <th colspan="2">Table 2.0 Analog Outputs</th> </tr> </thead> <tbody> <tr> <td>0 to 5 Volts</td> <td>The output is configured to drive a voltage output in the range of 0V to 5V. If feedback messages are used to send the output value to the bus, then the message will be sent with a resolution of 1mV/bit, and a 0mV offset.</td> </tr> <tr> <td>-5 to 5 Volts</td> <td>The output is configured to drive a voltage output in the range of -5V to 5V. If feedback messages are used to send the output value to the bus, then the message will be sent with a resolution of 1mV/bit, and a -5000mV offset.</td> </tr> <tr> <td>0 to 10 Volts</td> <td>The output is configured to drive a voltage output in the range of 0V to 10V. If feedback messages are used to send the output value to the bus, then the message will be sent with a resolution of 1mV/bit, and a 0mV offset.</td> </tr> <tr> <td>-10 to 10 Volts</td> <td>The output is configured to drive a voltage output in the range of -10V to 10V. If feedback messages are used to send the output value to the bus, then the message will be sent with a resolution of 1mV/bit, and a -10000mV offset.</td> </tr> <tr> <td>0(4) to 20 Milliamps</td> <td>The output is configured to source a current in the range of 0(4)mA to 20mA. If feedback messages are used to send the output value to the bus, then the message will be sent with a resolution of 1uA/bit, and a 0uA offset. Compliance voltage is up to 32Vdc.</td> </tr> </tbody> </table> | Table 2.0 Analog Outputs | | 0 to 5 Volts | The output is configured to drive a voltage output in the range of 0V to 5V. If feedback messages are used to send the output value to the bus, then the message will be sent with a resolution of 1mV/bit, and a 0mV offset. | -5 to 5 Volts | The output is configured to drive a voltage output in the range of -5V to 5V. If feedback messages are used to send the output value to the bus, then the message will be sent with a resolution of 1mV/bit, and a -5000mV offset. | 0 to 10 Volts | The output is configured to drive a voltage output in the range of 0V to 10V. If feedback messages are used to send the output value to the bus, then the message will be sent with a resolution of 1mV/bit, and a 0mV offset. | -10 to 10 Volts | The output is configured to drive a voltage output in the range of -10V to 10V. If feedback messages are used to send the output value to the bus, then the message will be sent with a resolution of 1mV/bit, and a -10000mV offset. | 0(4) to 20 Milliamps | The output is configured to source a current in the range of 0(4)mA to 20mA. If feedback messages are used to send the output value to the bus, then the message will be sent with a resolution of 1uA/bit, and a 0uA offset. Compliance voltage is up to 32Vdc. |
|---------------------------------|----------------------------------------------------------------------------------------------------------------------------------------------------------------------------------------------------------------------------------------------------------------------------------------------------------------------------------------------------------------------------------------------------------------------------------------------------------------------------------------------------------------------------------------------------------------------------------------------------------------------------------------------------------------------------------------------------------------------------------------------------------------------------------------------------------------------------------------------------------------------------------------------------------------------------------------------------------------------------------------------------------------------------------------------------------------------------------------------------------------------------------------------------------------------------------------------------------------------------------------------------------------------------------------------------------------------------------------------------------------------------------------------------------------------------------------------------------------------------------------------------------------------------------------------------------------------------------------------------------------------------------------------------------------------------------------------------------------------------------------------------------------------------------------------------------------------------------------------------------------|--------------------------|--|--------------|-------------------------------------------------------------------------------------------------------------------------------------------------------------------------------------------------------------------------------|---------------|------------------------------------------------------------------------------------------------------------------------------------------------------------------------------------------------------------------------------------|---------------|--------------------------------------------------------------------------------------------------------------------------------------------------------------------------------------------------------------------------------|-----------------|---------------------------------------------------------------------------------------------------------------------------------------------------------------------------------------------------------------------------------------|----------------------|------------------------------------------------------------------------------------------------------------------------------------------------------------------------------------------------------------------------------------------------------------------|
| Table 2.0 Analog Outputs | | | | | | | | | | | | | |
| 0 to 5 Volts | The output is configured to drive a voltage output in the range of 0V to 5V. If feedback messages are used to send the output value to the bus, then the message will be sent with a resolution of 1mV/bit, and a 0mV offset. | | | | | | | | | | | | |
| -5 to 5 Volts | The output is configured to drive a voltage output in the range of -5V to 5V. If feedback messages are used to send the output value to the bus, then the message will be sent with a resolution of 1mV/bit, and a -5000mV offset. | | | | | | | | | | | | |
| 0 to 10 Volts | The output is configured to drive a voltage output in the range of 0V to 10V. If feedback messages are used to send the output value to the bus, then the message will be sent with a resolution of 1mV/bit, and a 0mV offset. | | | | | | | | | | | | |
| -10 to 10 Volts | The output is configured to drive a voltage output in the range of -10V to 10V. If feedback messages are used to send the output value to the bus, then the message will be sent with a resolution of 1mV/bit, and a -10000mV offset. | | | | | | | | | | | | |
| 0(4) to 20 Milliamps | The output is configured to source a current in the range of 0(4)mA to 20mA. If feedback messages are used to send the output value to the bus, then the message will be sent with a resolution of 1uA/bit, and a 0uA offset. Compliance voltage is up to 32Vdc. | | | | | | | | | | | | |
| Output Accuracy | Voltage Output: +/- 0.2% Current Output: +/- 0.4% | | | | | | | | | | | | |
| Output Resolution | Voltage: 1 mV Current: 0.5 μ A | | | | | | | | | | | | |
| Output Grounds | 8 Analog Output GNDs are connected internally. | | | | | | | | | | | | |
| Output Adjust Rate | Approximately 1 mSec. | | | | | | | | | | | | |
| Short Circuit Protection | Individual short circuit protection is provided. | | | | | | | | | | | | |
| Other Protection | Each output is protected against shorts to GND or +Vcc. | | | | | | | | | | | | |
| Output Short Circuit Protection | Fully protected (all physical pins, all inputs, outputs and power) | | | | | | | | | | | | |
| Relay Output | <p>1 Form C Relay NC 3 contact pins per output Maximum electrical endurance at contact: 0.25A @ 250Vac 0.5A @ 125Vac 0.24A @ 125Vdc 2A @ 30Vdc</p> | | | | | | | | | | | | |

General Specifications

| | |
|----------------------------|----------------------------------------------------------------------------------------------------------------------------------------------------------------------------------------------------------------------------|
| Microprocessor | STM32F407ZG, ARM Cortex M4 32-bit, 1 Mbyte Flash Memory, 196 Kbyte SRAM |
| Control Logic | Standard embedded software is provided. <i>Refer to the user manual for details.</i> (Application-specific control logic is available on request.) |
| CAN Interface | 1 CAN port (SAE J1939) (CANopen® model: AX030211) Model AX030210: 250 kbps Baud Rate Model AX030210-01: 500 kbps Baud Rate Model AX030210-02: 1 Mbps Baud Rate Digital isolation is provided for the CAN line. |
| Isolation | 300Vrms Isolation for the CAN port |
| User Interface, Reflashing | Axiomatic Electronic Assistant AX070502 |

CAN (SAE J1939)

The software was designed to provide flexibility and provides the following.
 Configurable ECU Instance in the NAME (for multiple ECU's on the network)
 Configurable Input Parameters
 Configurable Output Parameters
 Configurable PGN and Data Parameters
 Configurable Diagnostic Messaging Parameters, as required
 Diagnostic Log maintained in non-volatile memory
Note: Configurable parameters are also called setpoints.

To use J1939 capabilities, refer to the user manual.

The Axiomatic AX030210 is compliant with Bosch CAN protocol specification, Rev.2.0, Part B, and the following J1939 standards.

| Table 4: J1939 Compliance | |
|---------------------------|--------------------------------------------------------------------------------------------------------------------------------------------------------------------------------------------------------------------------------------------------------------------------------------------------------------------------------------------------------------------------------------------------------------------------------------------------------------------------------------------------------------------------------------------------------------------------------------------------------------|
| OSI Network Model Layer | J1939 Standard |
| Physical | J1939/11 – Physical Layer, 250K bit/s, Twisted Shielded Pair. J1939/15 - Reduced Physical Layer, 250K bits/sec, Un-Shielded Twisted Pair (UTP). |
| Data Link | J1939/21 – Data Link Layer |
| | The controller supports Transport Protocol for Diagnostic DM1 and DM2 messages (PGN 65226 and 65227). It supports responses on PGN Requests (PGN 59904) and acknowledgements (PGN 59392). It also supports Proprietary B messaging (PGN 65280 to 65535), and uses a proprietary scheme described in the User Manual. |
| Network Layer | J1939/81 – Network Management J1939, Appendix B – Address and Identity Assignments |
| | Arbitrary Address Capable ECU - It can dynamically change its network address in real time. The controller supports: Address Claimed Messages (PGN 60928), Requests for Address Claimed Messages (PGN 59904) and Commanded Address Messages (PGN 65240). |
| Application Layer | J1939/71 – Vehicle Application Layer |
| | None of the application layer PGN's are supported as part of the default configurations. However, the controller could be configured such that any of the input messages to be sent will use a PGN from this section, or for the outputs to respond to the data in a message with a PGN from this section. The data size, index, resolution and offset can all be configured for the appropriate SPN associated with the PGN. <i>It is the user's responsibility to configure the controller such that it will not violate the J1939 standard.</i> |
| | J1939/73 – Application Layer – Diagnostics |
| | The controller can be configured to send "Active Diagnostic Trouble Code" DM1 messages (PGN 65226) for any I/O channel. Warning and Protect diagnostics will automatically become previously active when cleared. "Previously Active Diagnostic Trouble Codes" DM2 messages (PGN 65227) are available on request. Shutdown diagnostics will be cleared upon receiving a "Diagnostic Data Clear/Reset for Active DTC's" DM11 message (PGN 65235). Occurrence counts in the diagnostic log will be cleared upon receiving a "Diagnostic Data Clear/Reset for Previously Active DTC's" DM3 message (PGN 65228). |

| Operating Conditions | -40 to 85°C (-40 to 185°F) | | | | | | | | | | | | |
|-----------------------------------|-----------------------------------------------------------------------------------------------------------------------------------------------------------------------------------------------------------------------------------------------------------------------------------------------------------------------------------------------------------------------------------------------------------------------------------------------------------------------------------------------------------------------------------------------------------------------------------------------------------------------------------------------------------------------------------------------------------------------------------------------------------------------------------------------------------------------------------------------------------------------------------------------------|------------------------|---------------------|----------------|------------------------------------------|--------|------------------------------------------------|-----------|---------------------|-----------|---------------------------|-----|-----------------------------|
| Protection | IP67, Unit is conformally coated in the housing. Marine type approval tested to IP56. | | | | | | | | | | | | |
| Weight | 2.20 lbs. (0.99 kg) | | | | | | | | | | | | |
| Compliance | Designed to be compliant for EMC, CE marking Marine Type Approval – DNV-GL; BV; RINA | | | | | | | | | | | | |
| Vibration | MIL-STD-202G, Test 204D and 214A (Sine and Random) 10 g peak (Sine); 7.86 Grms peak (Random) | | | | | | | | | | | | |
| Shock | MIL-STD-202G, Test 213B, 50 g | | | | | | | | | | | | |
| Enclosure, Dimensions and Pin Out | Aluminum extrusion with stainless steel end plates. Gaskets are open cell neoprene. For dimensions and pin out, Refer to the Installation Instructions section. | | | | | | | | | | | | |
| Mating Plug Kit AX070200 | <p>Mating Plug Kit P/N: AX070200 This kit includes the following items. These items are also available from a local Deutsch IPD distributor. <i>NB. The sealing plugs are only needed in cases where not all of the 40 pins are used.</i> A crimping tool from Deutsch IPD is required to connect wiring to the sockets, P/N: HDT 48-00 or equivalent (not supplied).</p> <table border="1"> <thead> <tr> <th>TE Deutsch P/N:</th> <th>Description:</th> </tr> </thead> <tbody> <tr> <td>0462-201-16141</td> <td>48 16AWG SOCKETS SOLID 16-20AWG WIRE 6mm</td> </tr> <tr> <td>114017</td> <td>24 SEALING PLUGS SIZE 12-16 CAVITIES 12-18 AWG</td> </tr> <tr> <td>DRC16-40S</td> <td>40-PIN PLUG, No Key</td> </tr> <tr> <td>DT06-08SA</td> <td>DT SERIES PLUG 8 CONTACTS</td> </tr> <tr> <td>W8S</td> <td>WEDGELOCK FOR DT 8 PIN PLUG</td> </tr> </tbody> </table> | TE Deutsch P/N: | Description: | 0462-201-16141 | 48 16AWG SOCKETS SOLID 16-20AWG WIRE 6mm | 114017 | 24 SEALING PLUGS SIZE 12-16 CAVITIES 12-18 AWG | DRC16-40S | 40-PIN PLUG, No Key | DT06-08SA | DT SERIES PLUG 8 CONTACTS | W8S | WEDGELOCK FOR DT 8 PIN PLUG |
| TE Deutsch P/N: | Description: | | | | | | | | | | | | |
| 0462-201-16141 | 48 16AWG SOCKETS SOLID 16-20AWG WIRE 6mm | | | | | | | | | | | | |
| 114017 | 24 SEALING PLUGS SIZE 12-16 CAVITIES 12-18 AWG | | | | | | | | | | | | |
| DRC16-40S | 40-PIN PLUG, No Key | | | | | | | | | | | | |
| DT06-08SA | DT SERIES PLUG 8 CONTACTS | | | | | | | | | | | | |
| W8S | WEDGELOCK FOR DT 8 PIN PLUG | | | | | | | | | | | | |
| Grounding | <p>Protective Earth (PE) must be connected to the grounding stud to reduce the risk of electric shock. The conductor providing the connection should have a ring lug and wire larger than or equal to 4 mm² (12 AWG). The ring lug should be placed between the nut and a star washer. (To secure the ground strap, use an 8-32 “K-LOK” locknut, stainless steel, 3/8” O.D.)</p> <p>All chassis grounding should go to a single ground point designated for the machine and all related equipment.</p> <p>The ground strap that provides a low impedance path for EMI should be a ½ inch wide, flat, hollow braid, no more than 12 inches long with a suitable sized ring lug for the module’s grounding lug. It may be used in place of the PE grounding conductor and would then perform both PE and EMI grounding functions.</p> | | | | | | | | | | | | |
| Shielding | The CAN wiring should be shielded using a twisted conductor pair. All wire shields should be terminated externally to the grounding lug on the mounting foot. The input wires should not be exposed for more than 2 inches (50 mm) without shielding. Shields can be ac grounded at one end and hard grounded at the opposite end to improve shielding. If the module is installed in a cabinet, shielded wiring can be terminated at the cabinet (earth ground), at the entry to the cabinet or at the module. | | | | | | | | | | | | |
| CAN Wiring | <p>The CAN port is electrically isolated from all other circuits. The isolation is SELV rated with respect to product safety requirements. Refer to the CAN specification for more information.</p> <p>Use CAN compatible cabling. J1939 cable is recommended as it is rated for on-engine use.</p> <p>Shielded CAN cable is required. The module provides the CAN port shield connection ac coupled to chassis ground. The chassis ground stud located on the mounting foot must be tied directly to Earth Ground.</p> | | | | | | | | | | | | |
| Network Construction | Axiomatic recommends that multi-drop networks be constructed using a “daisy chain” or “backbone” configuration with short drop lines. | | | | | | | | | | | | |
| Termination | It is necessary to terminate the network with external termination resistors. The resistors are 120 Ohm, 0.25W minimum, metal film or similar type. They should be placed between CAN_H and CAN_L terminals at both ends of the network. | | | | | | | | | | | | |

| | |
|----------|-----------------------------------------------------------------------------------------------------------------------------------------------------------------------------------------------------------------------------------------------------------------------------------------------------------------------------------------------------------------------------------------------------------------------------------------------------------------------------------------------------------------------------------------------------------------------------------------------------------------------------------------------------------------------------------------------------------------------------------------------------------------------------------------------------------------------------------------------------------------------------------------------------------------------------------------------------------------------------------------------------------------------------------------------------------------|
| Mounting | <p>Mounting ledges include holes sized for ¼ inch or M6 bolts. The bolt length will be determined by the end-user's mounting plate thickness. Typically, ¾ inch (20 mm) is adequate.</p> <p>If the module is mounted without an enclosure, it should be mounted vertically with connectors facing left and right to reduce likelihood of moisture entry.</p> <p>The CAN wiring is considered intrinsically safe. The power wires are not considered intrinsically safe and so in hazardous locations, they need to be located in conduit or conduit trays at all times. The module must be mounted in an enclosure in hazardous locations for this purpose.</p> <p>No wire or cable harness should exceed 30 meters in length. The power input wiring should be limited to 10 meters.</p> <p>All field wiring should be suitable for the operating temperature range of the module.</p> <p>Install the unit with appropriate space available for servicing and for adequate wire harness access (6 inches or 15 cm) and strain relief (12 inches or 30 cm).</p> |
|----------|-----------------------------------------------------------------------------------------------------------------------------------------------------------------------------------------------------------------------------------------------------------------------------------------------------------------------------------------------------------------------------------------------------------------------------------------------------------------------------------------------------------------------------------------------------------------------------------------------------------------------------------------------------------------------------------------------------------------------------------------------------------------------------------------------------------------------------------------------------------------------------------------------------------------------------------------------------------------------------------------------------------------------------------------------------------------|



OUR PRODUCTS

Actuator Controls
Automotive Ethernet Converters
Battery Chargers
CAN bus Controls
CAN/Wifi, CAN/Bluetooth
Current/Voltage Converters
DC/DC Power Converters
Engine Temperature Scanners
Ethernet/CAN Converters, Switches
Fan Drive Controllers
Gateways, CAN/Modbus Protocols
Gyroscope Inclinometers
Hydraulic Valve Controllers
Inclinometers, Triaxial
I/O Controls
LVDT Simulators
Machine Controls
Modbus Controls
Motor Controls
Power Supplies
PWM Signal Converters/Isolators
Resolver Signal Conditioners
Service Tools
Signal Conditioners, Converters
Strain Gauge CAN Controls
Surge Suppressors

OUR COMPANY

Axiomatic provides electronic machine controls, components, and systems to the off-highway, commercial vehicle, electric vehicle, power generator set, material handling, renewable energy and industrial OEM markets.

We innovate with engineered and off-the-shelf machine controls that add value for our customers. We emphasize service and partnership with our customers, suppliers, and employees to build long term relationships and mutual trust.

QUALITY DESIGN AND MANUFACTURING

Axiomatic in Canada operates an ISO 9001:2015 registered design and manufacturing facility.

SERVICE

All products to be returned to Axiomatic require a Return Materials Authorization Number (RMA#). Please request an RMA# from sales@axiomatic.com.

Please provide the following information when requesting an RMA number:

- Serial number, part number
- Axiomatic invoice number and date
- Hours of operation, description of problem
- Wiring set up diagram, application
- Other comments as needed

All products should be serviced by Axiomatic. Do not open the product and perform the service yourself.

DISPOSAL

Axiomatic products are electronic waste. Please follow your local environmental waste and recycling laws, regulations and policies for safe disposal or recycling of electronic waste.

WARRANTY, APPLICATION APPROVALS/LIMITATIONS

Axiomatic Technologies Corporation reserves the right to make corrections, modifications, enhancements, improvements, and other changes to its products and services at any time and to discontinue any product or service without notice. Customers should obtain the latest relevant information before placing orders and should verify that such information is current and complete. Users should satisfy themselves that the product is suitable for use in the intended application. All our products carry a limited warranty against defects in material and workmanship. Please refer to our Warranty, Application Approvals/Limitations and Return Materials Process as described on www.axiomatic.com/service.html.

CONTACTS

Axiomatic Technologies Corporation
5915 Wallace Street
Mississauga, ON
CANADA L4Z 1Z8
TEL: +1 905 602 9270
FAX: +1 905 602 9279
www.axiomatic.com

Axiomatic Technologies Oy
Höytämöntie 6
33880 Lempäälä
FINLAND
TEL: +358 103 375 750
FAX: +358 3 3595 660
www.axiomatic.fi