

# 12 Input, 8 Signal Output & 1 Relay Output Controller with CANopen®

## USER MANUAL

P/N: AX030211



## OUR PRODUCTS

Actuator Controls  
Automotive Ethernet Converters  
Battery Chargers  
CAN bus Controls  
CAN/Wifi, CAN/Bluetooth  
Current/Voltage Converters  
DC/DC Power Converters  
Engine Temperature Scanners  
Ethernet/CAN Converters, Switches  
Fan Drive Controllers  
Gateways, CAN/Modbus Protocols  
Gyroscope Inclinometers  
Hydraulic Valve Controllers  
Inclinometers, Triaxial  
I/O Controls  
LVDT Simulators  
Machine Controls  
Modbus Controls  
Motor Controls  
Power Supplies  
PWM Signal Converters/Isolators  
Resolver Signal Conditioners  
Service Tools  
Signal Conditioners, Converters  
Strain Gauge CAN Controls  
Surge Suppressors

## OUR COMPANY

Axiomatic provides electronic machine controls, components, and systems to the off-highway, commercial vehicle, electric vehicle, power generator set, material handling, renewable energy and industrial OEM markets.

***We innovate with engineered and off-the-shelf machine controls that add value for our customers.*** We emphasize service and partnership with our customers, suppliers, and employees to build long term relationships and mutual trust.

## QUALITY DESIGN AND MANUFACTURING

Axiomatic in Canada operates an ISO 9001:2015 registered design and manufacturing facility.

## SERVICE

All products to be returned to Axiomatic require a Return Materials Authorization Number (RMA#). Please request an RMA# from [sales@axiomatic.com](mailto:sales@axiomatic.com).

Please provide the following information when requesting an RMA number:

- Serial number, part number
- Axiomatic invoice number and date
- Hours of operation, description of problem
- Wiring set up diagram, application
- Other comments as needed

All products should be serviced by Axiomatic. Do not open the product and perform the service yourself.

## DISPOSAL

Axiomatic products are electronic waste. Please follow your local environmental waste and recycling laws, regulations and policies for safe disposal or recycling of electronic waste.

## WARRANTY, APPLICATION APPROVALS/LIMITATIONS

Axiomatic Technologies Corporation reserves the right to make corrections, modifications, enhancements, improvements, and other changes to its products and services at any time and to discontinue any product or service without notice. Customers should obtain the latest relevant information before placing orders and should verify that such information is current and complete. Users should satisfy themselves that the product is suitable for use in the intended application. All our products carry a limited warranty against defects in material and workmanship. Please refer to our Warranty, Application Approvals/Limitations and Return Materials Process as described on [www.axiomatic.com/service.html](http://www.axiomatic.com/service.html).

## CONTACTS

**Axiomatic Technologies Corporation**  
5915 Wallace Street  
Mississauga, ON  
CANADA L4Z 1Z8  
TEL: +1 905 602 9270  
FAX: +1 905 602 9279  
[www.axiomatic.com](http://www.axiomatic.com)

**Axiomatic Technologies Oy**  
Höytämöntie 6  
33880 Lempäälä  
FINLAND  
TEL: +358 103 375 750  
FAX: +358 3 3595 660  
[www.axiomatic.fi](http://www.axiomatic.fi)

## VERSION HISTORY

<b>Version</b>	<b>Date</b>	<b>Author</b>	<b>Modification</b>
1.0.0.	Aug 16, 2019	Antti Keränen	Initial Version
1.0.1.	Feb 24, 2020	Antti Keränen	Objects 6340h, 7341h and 2353h added. Firmware reflashing instructions added. Resistive input's defaults updated in section 2.1.
-	April 21, 2020	Amanda Wilkins	Added Marine TAC, CE marking and Vibration test results
1.0.2	Dec. 10, 2020	Antti Keränen	Added a note about Frequency/PWM input type limitations.

## ACRONYMS

BATT +/-	Battery positive (a.k.a. Vps) or Battery Negative (a.k.a. GND)
CAN	Control Area Network
CANopen ®	CANopen ® is a registered community trademark of CAN in Automation e.V.
CAN-ID	CAN (11-bit or 29-bit) Identifier
COB	Communication Object
CTRL	Control
EDS	Electronic Data Sheet
EMCY	Emergency
GND	Ground reference (a.k.a. BATT-)
LSB	Least Significant Byte (or Bit)
LSS	Layer Settling Service
LUT	Lookup Table
MSB	Most Significant Byte (or Bit)
NMT	Network Management
RO	Read Only Object
RPDO	Received Data Object
RPM	Rotations per Minute
RW	Read/Write Object
SDO	Service Data Object
TPDO	Transmitted Process Data Object
Vps	Voltage Power Supply (a.k.a. BATT+)
WO	Write Only Object

# LIST OF CONTENTS

<b>1. OVERVIEW OF THE CONTROLLER</b> .....	<b>12</b>
<b>2. CONTROLLER FUNCTION BLOCKS</b> .....	<b>14</b>
2.1. Input Function Blocks .....	14
2.1.1. Resistive Input .....	20
2.1.2. Digital Input.....	20
2.2. Output Function Blocks.....	22
2.2.1. Relay Output.....	24
2.2.2. Reference Voltages .....	25
2.3. PID Function Block .....	25
2.4. Lookup Table Function Block .....	27
2.4.1. X-Axis, Input Data Response .....	28
2.4.2. Y-Axis, Lookup Table Output.....	28
2.4.3. Point to Point Response .....	28
2.4.4. X-Axis, Time Response .....	30
2.5. Programmable Logic Function Block.....	31
2.5.1. Conditions Evaluation .....	34
2.5.2. Table Selection .....	35
2.5.3. Logic Block Output.....	37
2.6. Math Function Block .....	38
2.7. Miscellaneous Function Block .....	40
2.8. Available Control Sources .....	42
2.9. Diagnostics .....	43
<b>3. INSTALLATION INSTRUCTIONS</b> .....	<b>44</b>
3.1. Dimensions and Pinout.....	44
<b>4. CANOPEN INTERFACE AND OBJECT DICTIONARY</b> .....	<b>45</b>
4.1. Node ID and Baud rate .....	45
4.1.1. LSS Protocol to Update .....	45
4.1.1.1. Setting Node-ID .....	45
4.1.1.2. Setting Baud rate .....	46
4.2. Communication Objects (DS-301).....	49
4.2.1. 1000h Device Type.....	50
4.2.2. 1001h Error Register .....	50
4.2.3. 1002h Manufacturer Status Object.....	50
4.2.4. 1003h Pre-Defined Error Field.....	50
4.2.5. 1010h Store Parameters.....	50
4.2.6. 1011h Restore Parameters .....	51
4.2.7. 1016h Consumer Heartbeat Time .....	51
4.2.8. 1017h Producer Heartbeat Time .....	51
4.2.9. 1018h Identity Object.....	51

4.2.10.	1020h Verify Configuration .....	51
4.2.11.	1029h Error Behavior.....	52
4.2.12.	1400h RPDO 1 Communication Parameters .....	52
4.2.13.	1401h RPDO 2 Communication Parameters .....	52
4.2.14.	1402h RPDO 3 Communication Parameters .....	52
4.2.15.	1403h RPDO 4 Communication Parameters .....	52
4.2.16.	1600h RPDO 1 Mapping Parameters.....	53
4.2.17.	1601h RPDO 2 Mapping Parameters.....	53
4.2.18.	1602h RPDO 3 Mapping Parameters.....	53
4.2.19.	1603h RPDO 4 Mapping Parameters.....	53
4.2.20.	1800h TPDO 1 Communication Parameters.....	53
4.2.21.	1801h TPDO 2 Communication Parameters.....	54
4.2.22.	1802h TPDO 3 Communication Parameters.....	54
4.2.23.	1803h TPDO 4 Communication Parameters.....	54
4.2.24.	1A00h TPDO 1 Mapping Parameters.....	54
4.2.25.	1A01h TPDO 2 Mapping Parameters.....	54
4.2.26.	1A02h TPDO 3 Mapping Parameters.....	55
4.2.27.	1A03h TPDO 4 Mapping Parameters.....	55
4.3.	Application Objects .....	56
4.3.1.	6000h DI Read State 8 Input Lines .....	57
4.3.2.	6002h DI Polarity 8 Input Lines .....	57
4.3.3.	6110h AI Sensor Type.....	57
4.3.4.	6112h AI Operating Mode .....	57
4.3.5.	6132h AI Decimal Digits PV .....	57
4.3.6.	61A0h AI Filter Type.....	58
4.3.7.	61A1h AI Filter Constant .....	58
4.3.8.	6302h AO Decimal Digits PV.....	58
4.3.9.	6310h AO Output Type.....	58
4.3.10.	6332h AO Decimal Digits FV.....	58
4.3.1.	6340h AO Fault Mode.....	58
4.3.2.	6458h PID Physical Unit Timing .....	58
4.3.3.	6459h PID Decimal Digits Timing.....	59
4.3.4.	7100h AI Input Field Value .....	59
4.3.5.	7120h AI Input Scaling 1 FV.....	59
4.3.6.	7121h AI Input Scaling 1 PV.....	59
4.3.7.	7122h AI Input Scaling 2 FV.....	59
4.3.8.	7123h AI Input Scaling 2 PV.....	59
4.3.9.	7130h AI Input Process Value .....	59
4.3.10.	7148h AI Input Span Start .....	60
4.3.11.	7149h AI Input Span End .....	60

4.3.12.	7300h AO Output Process Value .....	60
4.3.13.	7320h AO Output Scaling 1 PV .....	60
4.3.14.	7321h AO Output Scaling 2 FV .....	60
4.3.15.	7322h AO Output Scaling 1 PV .....	60
4.3.16.	7323h AO Output Scaling 2 FV .....	61
4.3.17.	7330h AO Output Field Value.....	61
4.3.18.	7341h AO Output Fault FV .....	61
4.3.19.	7450h PID Proportional Band.....	61
4.3.20.	7452h PID Integral Action Time.....	61
4.3.21.	7454h PID Derivative Action Time.....	61
4.3.22.	7456h PID Cycle Time.....	61
4.4.	Manufacturer Objects .....	62
4.4.1.	2020h DI Pull Up Down Mode 1 Input Line .....	64
4.4.2.	2100h AI Input Range.....	64
4.4.3.	2101h AI Number of Pulses per Revolution .....	64
4.4.4.	2102h AI Decimal Digits FV.....	64
4.4.5.	2103h AI Debounce Filter .....	64
4.4.6.	2110h AI Error Detect Enable.....	64
4.4.7.	2111h AI Error Clear Hysteresis.....	65
4.4.8.	2112h AI Error Reaction Delay.....	65
4.4.9.	2302h AO Output Range .....	65
4.4.10.	2330h AO Ramp Up .....	65
4.4.11.	2331h AO Ramp Down.....	65
4.4.12.	2340h AO Control Input Source .....	65
4.4.13.	2341h AO Control Input Number .....	66
4.4.14.	2350h AO Enable Input Source.....	66
4.4.15.	2351h AO Enable Input Number .....	66
4.4.16.	2352h AO Enable Response .....	66
4.4.17.	2353h AO Disable Drive FV .....	66
4.4.18.	2360h AO Override Input Source .....	67
4.4.19.	2361h AO Override Input Number.....	67
4.4.20.	2362h AO Override Response .....	67
4.4.21.	2450h PID Tolerance.....	67
4.4.22.	2451h PID Integral Gain .....	67
4.4.23.	2452h PID Derivative Gain .....	67
4.4.24.	2453h PID Target Source .....	68
4.4.25.	2454h PID Target Number .....	68
4.4.26.	2455h PID Feedback Source .....	68
4.4.27.	2456h PID Feedback Number.....	68
4.4.28.	2457h PID Control Response.....	68

4.4.29.	2460h PID Output FV .....	68
4.4.30.	2500h EC Extra Received PV .....	68
4.4.31.	2502h EC Decimal Digits PV .....	69
4.4.32.	2520h EC Scaling 1 PV .....	69
4.4.33.	2522h EC Scaling 2 PV .....	69
4.4.34.	30z0h LT0z Input X Axis Source .....	69
4.4.35.	30z1h LT0z Input X Axis Number .....	69
4.4.36.	30z2h LT0z Auto Repeat .....	69
4.4.37.	30z3h LT0z X Axis Decimal Digits .....	70
4.4.38.	30z4h LT0z Y Axis Decimal Digits .....	70
4.4.39.	30z5h LT0z Point Response .....	70
4.4.40.	30z6h LT0z X Axis Process Value .....	70
4.4.41.	30z7h LT0z Y Axis Process Value .....	70
4.4.42.	30z8h LT0z Output Y Axis Process Value .....	70
4.4.43.	3300h Logic Block Enable .....	71
4.4.44.	3310h Logic Block Selected Table .....	71
4.4.45.	3320h Logic Block Output Process Value .....	71
4.4.46.	3x01h Logic Block (x-3) Lookup Table Number .....	71
4.4.47.	3x02h Logic Block (x-3) Function Logical Operator .....	71
4.4.48.	3x11h Logic Block (x-3) Function A Condition 1 .....	71
4.4.49.	3x12h Logic Block (x-3) Function A Condition 2 .....	72
4.4.50.	3x13h Logic Block (x-3) Function A Condition 3 .....	72
4.4.51.	3x21h Logic Block (x-3) Function B Condition 1 .....	72
4.4.52.	3x22h Logic Block (x-3) Function B Condition 2 .....	72
4.4.53.	3x23h Logic Block (x-3) Function B Condition 3 .....	73
4.4.54.	3x31h Logic Block (x-3) Function C Condition 1 .....	73
4.4.55.	3x32h Logic Block (x-3) Function C Condition 2 .....	73
4.4.56.	3x33h Logic Block (x-3) Function C Condition 3 .....	73
4.4.57.	4000h Math Function Enable .....	74
4.4.58.	4021h Math Function Output Scaling 1 PV .....	74
4.4.59.	4023h Math Function Output Scaling 2 PV .....	74
4.4.60.	4030h Math Function Output Process Value .....	74
4.4.61.	4032h Math Function Output PV Decimal Digits .....	74
4.4.62.	4y00h Math #y Input Source .....	74
4.4.63.	4y01h Math #y Input Number .....	74
4.4.64.	4y03h Math #y Input Decimal Digits FV .....	75
4.4.65.	4y20h Math #y Input Scaling 1 FV .....	75
4.4.66.	4y22h Math #y Input Scaling 2 FV .....	75
4.4.67.	4y40h Math #y Input Gain .....	75
4.4.68.	4y50h Math #y Operator .....	75

4.4.69.	5010h Constant Field Value .....	75
4.4.70.	5020h Power Supply FV .....	76
4.4.71.	5030h CPU Temperature FV .....	76
4.4.72.	5040h FD Field Value .....	76
4.4.73.	5041h FD Set Threshold .....	76
4.4.74.	5042h FD Clear Threshold .....	76
4.4.75.	5050h FD Enable 3 Faults .....	76
4.4.76.	5051h FD Error Response Delay .....	77
4.4.77.	5120h VREF Control Source .....	77
4.4.78.	5121h VREF Control Number.....	77
4.4.79.	5555h Start In Operational Mode .....	77
4.4.80.	5556h Start In Operational NMT Delay .....	77
<b>5.</b>	<b>FIRMWARE REFLASHING INSTRUCTIONS .....</b>	<b>78</b>
	<b>APPENDIX A - TECHNICAL SPECIFICATION.....</b>	<b>A-1</b>

## LIST OF TABLES

Table 1 – Object 6112h - AI Operating Mode Options .....	14
Table 2 – Object 6110h - AI Sensor Type Options.....	14
Table 3 – AI Input Range Options Depending on Sensor Type .....	15
Table 4 – DI Debounce Filter Options .....	15
Table 5 – Object 61A0h - AI Filter Type Options.....	16
Table 6 – Object 2102h AI Decimal Digits FV Depending on Sensor Type .....	17
Table 7 – AI Object Defaults Based on Sensor Type and Input Range .....	18
Table 8 – AI Object Ranges Based on Sensor Type and Input Range .....	19
Table 9 – DI Pullup/Down Options .....	20
Table 10 – Object 6002h DI Polarity 8 Input Lines Options .....	21
Table 11 – Object 6310h AO Output Type Options.....	23
Table 12 – AO Output Range Options Depending on Output Type .....	23
Table 13 – AO Object Defaults Based on Output Type and Input Range.....	23
Table 14 – PID Control Response Options .....	26
Table 15 – LTyz Point Response Options.....	30
Table 16 – LB(x-3) Condition Structure Definition.....	34
Table 17 – LB(x-3) Condition Operator Options.....	34
Table 18 – LB(x-3) Condition Evaluation Results.....	35
Table 19 – LB(x-3) Function Logical Operator Options.....	35
Table 20 – LB(x-3) Conditions Evaluation Based on Selected Logical Operator.....	36
Table 21 – LB(x-3) Default Lookup Tables.....	37
Table 22 – Object 4y50h Math Function Operators .....	39
Table 23 – Available Control Sources and Numbers .....	42
Table 24 – Scaling Limits per Control Source .....	43
Table 25 – EMCY codes.....	43
Table 26 – AX030211 Connector Pinouts .....	44
Table 27 – LSS Baud rate Indices.....	47

## LIST OF FIGURES

Figure 1 – AX030210 Block Diagram .....	12
Figure 2 – Analog Input Objects .....	14
Figure 3 – Digital Input Debouncing .....	16
Figure 4 – Analog Input Linear Scaling FV to PV .....	17
Figure 5 – Digital Input Objects .....	20
Figure 6 – Discrete Input Hysteresis .....	21
Figure 7 – Analog Input Reads as Digital .....	22
Figure 8 – Analog Output Objects .....	22
Figure 9 – Analog Output Linear Scaling PV to FV .....	24
Figure 10 – PID Control Objects .....	25
Figure 11 – PID Control Algorithm .....	26
Figure 12 – Lookup Table Objects .....	27
Figure 13 – Lookup Table Defaults with Ramp and Step Responses .....	29
Figure 14 – Lookup Table Examples to Setup for Dual-Slope Joystick Deadband Response .....	29
Figure 15 – Logic Block Objects .....	31
Figure 16 – Logic Block Flowchart .....	33
Figure 17 – Math Function Block Objects .....	38
Figure 18 – Miscellaneous Objects .....	40
Figure 19 – AX030211 Dimensional Drawing .....	44

## REFERENCES

- TDAX030210      Technical Datasheet, 12 Inputs, 8 Signal Outputs & 1 Relay Output Controller with CAN, Axiomatic Technologies 2018
- [DS-301]        CiA DS-301 V4.1 – CANopen Application Layer and Communication Profile. CAN in Automation 2005
- [DS-305]        CiA DS-305 V2.0 – Layer Setting Service (LSS) and Protocols. CAN in Automation 2006
- [DS-404]        CiA DS-404 V1.2 – CANopen profile for Measurement Devices and Closed Loop Controllers. CAN in Automation 2002

The Communication/Device Profile documents are available from the CAN in Automation e.V. website <http://www.can-cia.org/>.

# 1. Overview of The Controller

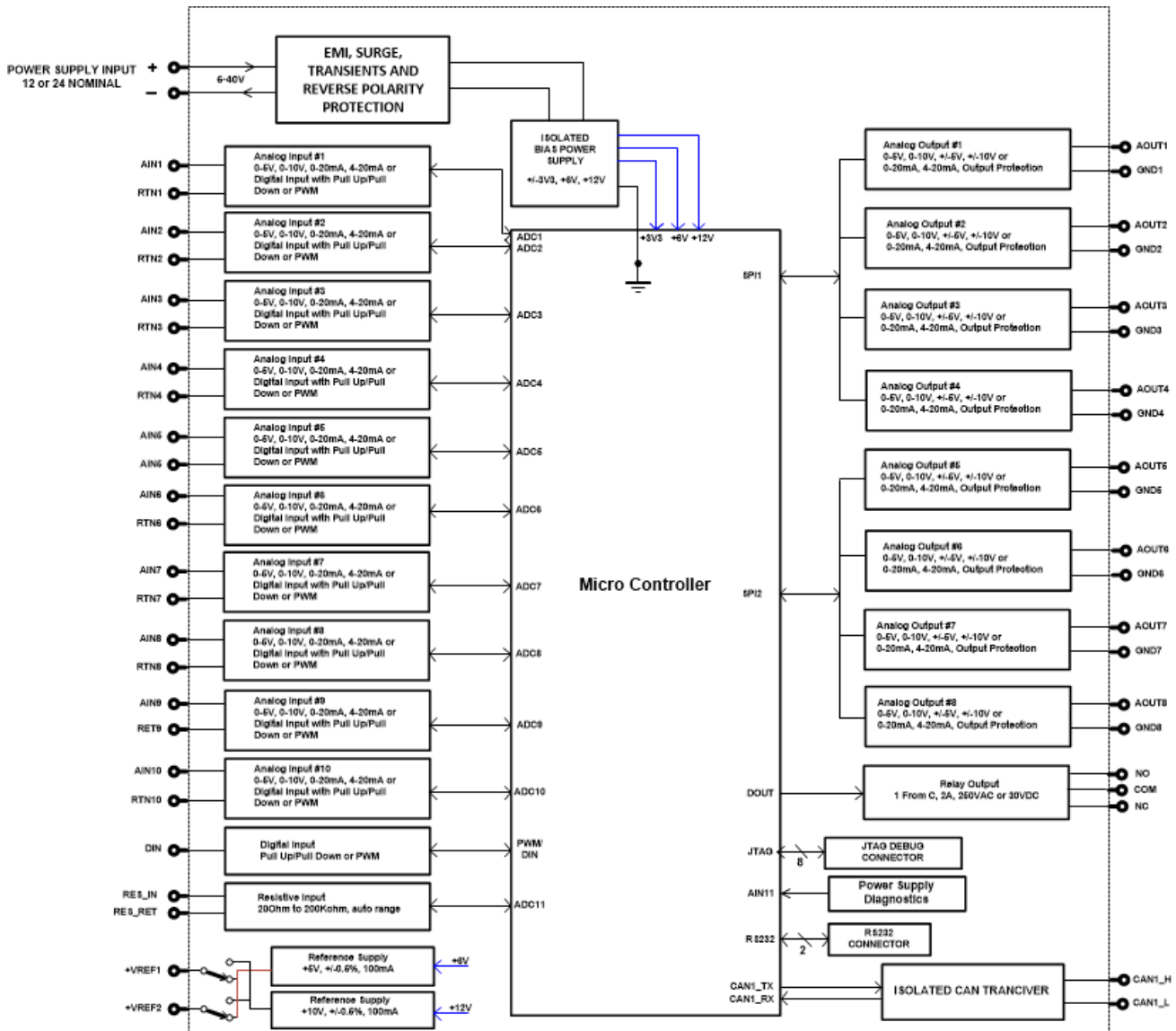

**Figure 1 – AX030210 Block Diagram**

The 12 Input, 8 Signal Outputs & 1 Relay Output Controller with CANopen (later 12IN-8SOUT-CO) is designed for extremely versatile control of up to eight signal outputs for generating control signals and one relay output to drive other loads. Its flexible circuit design gives the user a wide range of configurable input and output types. The sophisticated control algorithms allow the user to program the controller for a wide range of applications without the need for custom software.

The controller has ten Universal inputs that can be configured to measure analog voltage or current, frequency/PMW or digital signal, one resistive input capable of measuring resistances from 25Ω to 250kΩ and one Digital input that can be configured to measure digital on/off signals. Measured input data can be sent to CANopen Network or used to drive outputs directly or through the configurable control algorithms.

Signal outputs can be configured to generate voltage and current signals. Any of the eight signal outputs can be configured to use any of the on-board inputs as either a control signal or an enable signal as well as CANopen Network data.

All CANopen objects supported by the AX030211 are user configurable using standard commercially available tools that can interact with a CANopen® Object Dictionary via an .EDS file.

In this document, the configurable properties of the ECU are divided into function blocks, namely Input Function Block, Output Function Block, Diagnostic Function Block, PID Control Function Block, Lookup Table Function Block, Programmable Logic Function Block, Math Function Block, DTC React Function Block, CAN Transmit Message Function Block and CAN Receive Message Function Block. These function blocks are presented in detail in next subchapters.

## 2. Controller Function Blocks

### 2.1. Input Function Blocks

The controller has altogether twelve inputs. The ten Universal Inputs can be configured to measure voltage, current, frequency, pulse width (PWM) or digital signals. The Resistive input can measure resistances in range 25Ω ... 250kΩ. The Digital Input can be configured to measure digital signals.

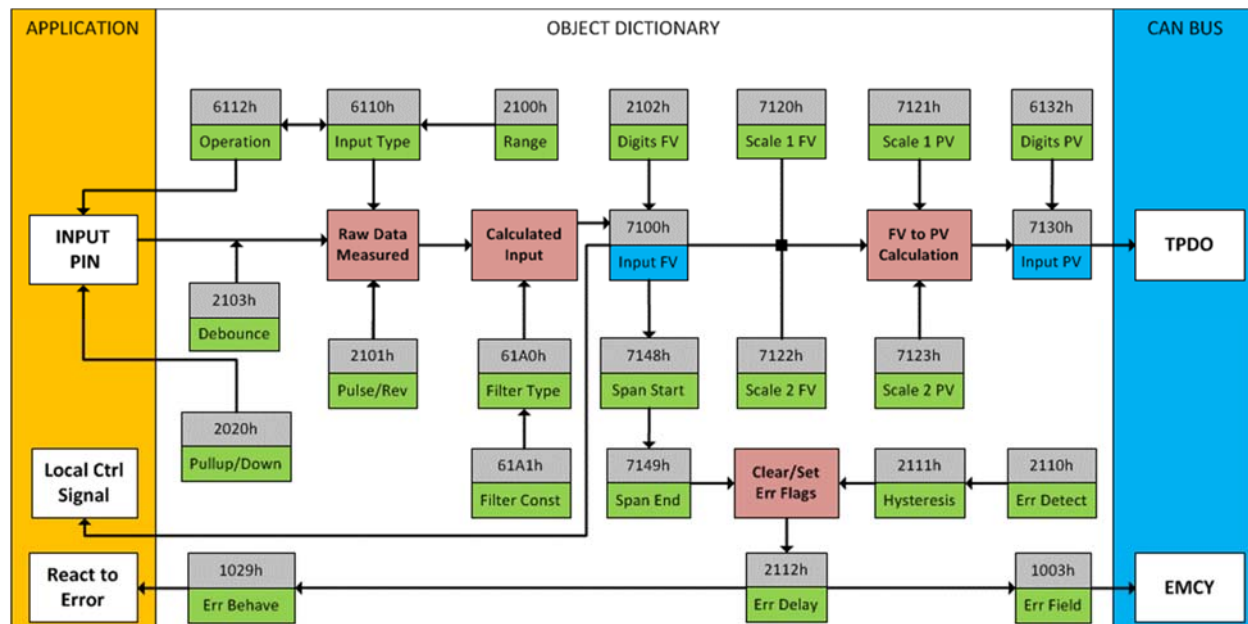

Figure 2 – Analog Input Objects

Object 6112h, **AI Operating Mode** determines whether the AI or DI block is associated with an input. The options for object 6112h are shown in Table 1. No values other than what are shown here will be accepted.

Value	Meaning
0	Channel Off
1	<b>Normal Operation (analog)</b>
10	Digital Input (on/off)
20	Analog and On/Off

Table 1 – Object 6112h - AI Operating Mode Options

The most important object associate with the AI function block is object 6110h **AI Sensor Type**. By changing this value, and the object 2100h **AI Input Range** associated with it, other objects will be automatically updated by the controller. The options for object 6110h are shown in Table 2, and no values other than what are shown here will be accepted. The inputs are setup to measure voltage by default.

Value	Meaning
40	<b>Voltage Input</b>
50	Current Input
60	Frequency Input (or RPM)
100	Resistive
10000	PWM Input

Table 2 – Object 6110h - AI Sensor Type Options

The allowable ranges will depend on the input sensor type selected. Table 3 shows the relationship between the sensor type, and the associated range options. The default value for each range is bolded, and object 2100h **AI Range** will automatically be updated with this value when 6110h is changed. The grayed cells mean that the associate value is not allowed for the range object when that sensor type has been selected.

Value	Voltage	Current	Frequency	Resistive	PWM
0	<b>0 to 5V</b>	<b>0 to 20mA</b>	<b>0.5Hz to 50Hz</b>	<b>20 Ω to 250 kΩ</b>	<b>Low Freq (&lt;1kHz)</b>
1	0 to 10V	4 to 20mA	10Hz to 1kHz		High Freq (>100Hz)
2			100Hz to 10kHz		

**Table 3 – AI Input Range Options Depending on Sensor Type**



**NOTE: The input channels 3, 6, 7 and 8 have limited accuracy when used for detecting edges (Frequency / PWM measurements). The measurement accuracy can be enhanced using software filtering, but in case the Frequency or PWM duty cycle measurements need to have high accuracy, please avoid using these four channels.**



**NOTE: The input channels 3 & 8 and 6 & 7 share the timer peripheral used for Frequency / PWM measurements. This limits the Frequency and PWM measurement configuration options available for these inputs. Both inputs of the pair need to be configured to use the same frequency detection range.**

Objects 2020h **DI Pull-up/Pull-down Mode**, 2030h **DI Debounce Filter** and 2101h **AI Number of Pulses per Revolution** are used with frequency and PWM sensor types.

Object 2020h **DI Pull-up/Pull-down Mode** will determine the configuration of the internal Pull-up/Pull-down resistors. The options for object 2020h are shown in Table 9, with the default bolded.

Object 2030h **DI Debounce Filter** is used to select input capture filter applied to the input before the state is read by the processor. The options for object 2030h are shown in Table 4, with the default bolded.

Value	Meaning
0	Filter Disabled
1	Filter 111ns
2	<b>Filter 1.78 us</b>
3	Filter 14.22 us

**Table 4 – DI Debounce Filter Options**

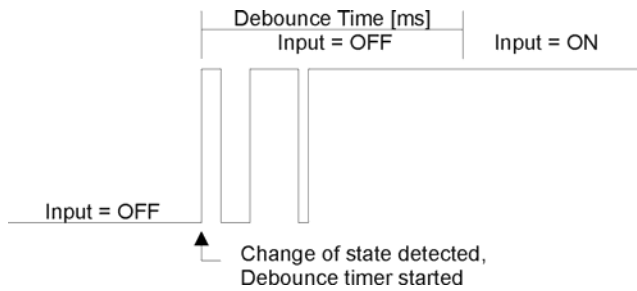

**Figure 3 – Digital Input Debouncing**

Frequency measurement can be changed to RPM, by setting object 2101h **AI Number of Pulses per Revolution** to a non-zero value.

All inputs can be further filtered once the raw data has been measured. Object 61A0h **AI Filter Type** determines what kind of filter is used per Table 5. By default, additional software filtering is disabled.

Value	Meaning
0	No Filter
1	Moving Average
2	Repeating Average

**Table 5 – Object 61A0h - AI Filter Type Options**

Object 61A1h **AI Filter Constant** is used with all three types of filters as per the formulas below:

Calculation with no filter:

$$\text{Value} = \text{Input}$$

The data is simply a ‘snapshot’ of the latest value measured by the ADC or timer.

Equation 1 - Moving Average Transfer Function:

$$\text{Value}_N = \text{Value}_{N-1} + \frac{(\text{Input} - \text{Value}_{N-1})}{\text{Filter Constant}}$$

This filter is called every 1ms. The value Filter Constant stored in object 61A1h is 10 by default.

Equation 2 - Repeating Average Transfer Function:

$$\text{Value} = \frac{\sum_0^N \text{Input}_N}{N}$$

At every reading of the input value, it is added to the sum. At every N<sup>th</sup> read, the sum is divided by N, and the result is the new input value. The value and counter will be set to zero for the next read. The value of N is stored in object 61A1h and is 10 by default. This filter is called every 1ms.

The value from the filter is shifted according to read-only object 2102h **AI Decimal Digits FV** and then written to read-only object 7100h **AI Input Field Value**.

The value of 2102h will depend on the **AI Sensor Type** and **Pulses per Revolution** selected and will be automatically updated per Table 7 when either 6110h or 2101h are changed. All other objects associated with the input field value also apply this object. These objects are 7120h **AI Scaling 1 FV**, 7122h **AI Scaling 2 FV**, 7148h **AI Span Start**, 7149h **AI Span End**, and 2111h **AI Error Clear Hysteresis**. These objects are also automatically updated when the Type or Pulses per Rev are changed.

Sensor Type	Decimal Digits
Voltage: All Ranges	3 [mV]
Current: All Ranges	3 [uA]
Frequency: 0.5Hz to 50Hz	2 [0.01 Hz]
Frequency: 10Hz to 1kHz	1 [0.1 Hz]
Frequency: 100Hz to 10kHz	0 [Hz]
Frequency: RPM Mode	1 [0.1 RPM]
Resistive	0 [1 kΩ]
PWM: All Ranges	1 [0.1 %]
Digital Input	0 [On/Off]

**Table 6 – Object 2102h AI Decimal Digits FV Depending on Sensor Type**

It is the **AI Input FV** which is used by the application for error detection, and as a control signal for other logic blocks (i.e. output control.) Object 7100h is mappable to a TPDO and is mapped to TPDO1 by default.

Read-only object 7130h **AI Input Process Value** is also mappable. However, the default values for objects 7121h **AI Scaling 1 PV** and 7123h **AI Scaling 2 PV** are set to equal 7120h and 7122h respectively, while object 6132h **AI Decimal Digits PV** is automatically initialize to equal 2102h. This means that the default relationship between the FV and PV is one-to-one, so object 7130h is not mapped to a TPDO by default.

Should a different linear relationship between what is measured versus what is sent to the CANopen bus be desired, objects 6132h, 7121h and 7123h can be changed. The linear relationship profile is shown in Figure 7 below. Should a non-linear response be desired, the lookup table function block can be used instead, as described in Section 2.3.

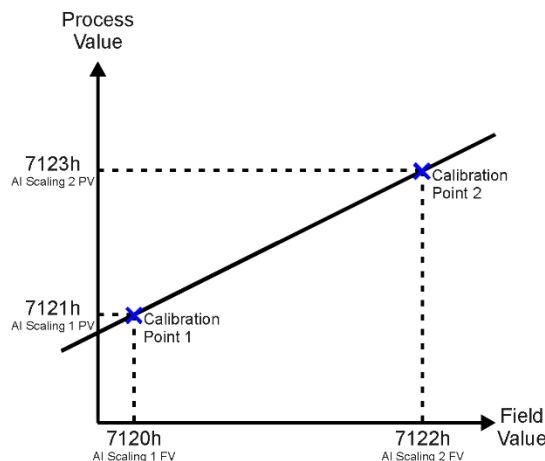

**Figure 4 – Analog Input Linear Scaling FV to PV**

As stated earlier, the FV scaling objects are automatically updated with the Sensor Type or Range changes. This is because objects 7120h and 7122h are not only used in a linear conversion from FV

to PV as described above, but also as the minimum and maximum limits when the input is used to control another logic block. Therefore, the values in these objects are important, even when the AI Input PV object is not being used.

The AI Span Start and AI Span End objects are used for fault detection, so they too are automatically updated for sensible values as the Type/Range changes. The Error Clear Hysteresis object is also updated, as it too is measured in the same unit as the AI Input FV object.

Table 7 lists the default values that are loaded into objects 7120h, 7122h, 7148h, 7149h, and 2111h for each Sensor Type and Pulses per Rev combination. Recall that these objects all have the decimal digits applied to them as outlined in Table 8.

Sensor Type/ Input Range	7148h AI Span Start (i.e. Error Min)	7120h AI Scaling 1 FV (i.e. Input Min)	7122h AI Scaling 2 FV (i.e. Input Max)	7149h AI Span End (i.e. Error Max)	2111h Error Clear Hysteresis
Voltage: 0 to 5V	200 [mV]	500 [mV]	4500 [mV]	4800 [mV]	100 [mV]
Voltage: 0 to 10V	200 [mV]	500 [mV]	9500 [mV]	9800 [mV]	200 [mV]
Current: 0 to 20mA	0 [uA]	0 [uA]	20000 [uA]	20000 [uA]	250 [uA]
Current: 4 to 20mA	1000 [uA]	4000 [uA]	20000 [uA]	21000 [uA]	250 [uA]
Freq: 0.5Hz to 50Hz	100 [0.01Hz]	500 [0.01Hz]	5000 [0.01Hz]	5500 [0.01Hz]	20 [0.01Hz]
Freq: 10Hz to 1kHz	50 [0.1Hz]	100 [0.1Hz]	10000 [0.1Hz]	11000 [0.1Hz]	50 [0.1Hz]
Freq: 100Hz to 10kHz	50 [Hz]	100 [Hz]	10000 [Hz]	10500 [Hz]	10 [Hz]
Freq: RPM Mode	500 [0.1RPM]	1000 [0.1RPM]	30000 [0.1RPM]	33000 [0.1RPM]	100 [0.1RPM]
Resistive	1[1kΩ]	0[1kΩ]	250 [1kΩ]	249 [1kΩ]	1[1kΩ]
PWM: 0 to 100%	10 [0.1%]	50 [0.1%]	950 [0.1%]	990 [0.1%]	10 [0.1%]
Digital Input	OFF	OFF	ON	ON	0

**Table 7 – AI Object Defaults Based on Sensor Type and Input Range**

It might not be desired in a particular application for the automatic updating of objects when a key object is changed, i.e. AI Sensor Type. In this case, object 5550h **Enable Automatic Updates** can be set to FALSE (true by default) in which case changing an object will have no impact on any other objects. In this mode, the user must manually change all the objects for sensible values or the controller will not work as expected.

When changing these objects, Table 8 outlines the range constraints places on each based on the Sensor Type and Input Range combination selected. In all cases, the MAX value is the upper end of the range (i.e. 50000Hz or ) Object 7122h cannot be set higher than MAX, whereas 7149h can be set up to 110% of MAX. Object 2111h on the other hand can only be set up to maximum value of 10% of MAX. Table 8 uses the base unit of the input, but recall the limits will also have object 2102h apply to them as per Table 6

Sensor Type/ Pulses per Rev	7148h	7120h	7122h	7149h	2111h
Voltage: 0 to 5V and 0 to 10V Current: 0 to 20mA and 4 to 20mA RPM: 0 to 6000RPM PWM: 0 to 100%	0 to 7120h	7148h to 7122h	7120h to 7149h If(7149h>MAX) 7120h to MAX	7122h to 110% of MAX	10% of MAX
Current: 4 to 20mA	0 to 7120h	7148h to 7122h If(7148h<4mA) 4mA to 7122h			
Freq: 0.5Hz to 50Hz	0.1Hz to 7120h	7148h to 7122h If(7148h<0.5Hz) 0.5Hz to 7122h			
Freq: 10Hz to 1kHz	5Hz to 7120h	7148h to 7122h If(7148h<10Hz) 10Hz to 7122h			
Freq: 100Hz to 10kHz	50Hz to 7120h	7148h to 7122h If(7148h<100Hz) 100Hz to 7122h			
Voltage: 0 to 5V and 0 to 10V Current: 0 to 20mA and 4 to 20mA RPM: 0 to 6000RPM PWM: 0 to 100%	0 to 7120h	7148h to 7122h			

**Table 8 – AI Object Ranges Based on Sensor Type and Input Range**

The last objects associated with the analog input block left to discuss are those associated with fault detection. Should the calculated input (after measuring and filtering) fall outside of the allowable range, as defined by the AI Span Start and AI Span End objects, an error flag will be set in the application if and only if object 2110h **AI Error Detect Enabled** is set to TRUE (1).

When (7100h AI Input FV < 7148h AI Span Start), an “Out of Range Low” flag is set. If the flag stays active for the 2112h **AI Error Reaction Delay** time, an Input Overload Emergency (EMCY) message will be added to object 1003h **Pre-Defined Error Field**. Similarly, when (7100h AI Input FV > 7149h AI Span End), an “Out of Range High” flag is set and will create an EMCY message should it stay active throughout the delay period. In either case, the application will react to the EMCY message as defined by object 1029h **Error Behaviour** at the sub-index corresponding to an Input Fault.

Once the fault has been detected, the associate flag will be cleared only once the input comes back into range. Object 2111h **AI Error Clear Hysteresis** is used here so that the error flag will not be set/cleared continuously while the AI Input FV hovers around the AI Span Start/End value.

To clear an “Out of Range Low” flag, AI Input FV >= (AI Span Start + AI Error Clear Hysteresis)

To clear an “Out of Range High” flag, AI Input FV <= (AI Span End - AI Error Clear Hysteresis)

Both flags cannot be active at once. Setting either one of these flags automatically clears the other.

### 2.1.1. Resistive Input

The controller has one Resistive Input in the 8 pin Deutsch connector that can measure resistances and it can be also configured to measure Digital On/Off states. The Digital On/Off state reading is done using an ADC and comparing the conversion results to built-in thresholds.

The preferred Digital Input voltages to the Resistive Input are 0V (low) and 5V (high).

When configured as a Resistive Input, the controller uses the ADC and internal reference current generator to measure the resistance between the Resistive Input pins.

The default resistive input measurement unit in object 7100h is kΩ.

### 2.1.2. Digital Input

The Digital Input located also in the 8 pin Deutsch connector is capable of detecting Digital On/Off states. It does not require any specific configuration, the 'on/off' state can be read directly from AI Input Field/Process Value objects and from object 6000h.

The Universal Inputs can operate as digital inputs using the digital input (DI) function block. It only becomes applicable on the input when object 6112h, **AI Operation**, is set to a digital input response.

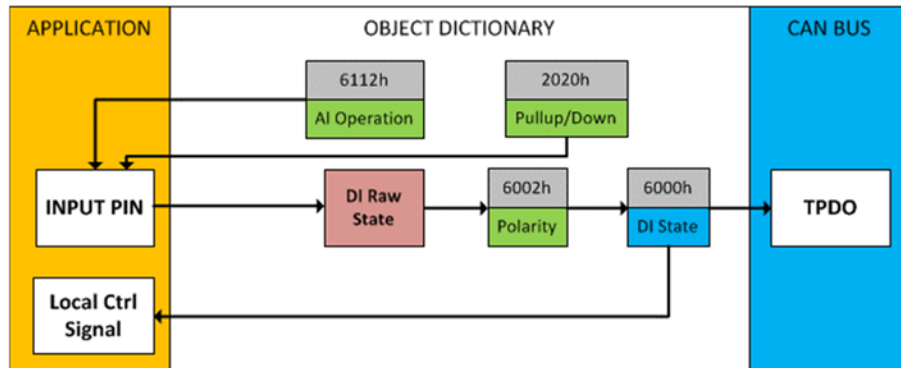

**Figure 5 – Digital Input Objects**

When object 6112h is set to 10 = *Digital Input*, object 2020h **DI Pull-up/Pull-down Mode** will determine the configuration of the internal Pull-up/Pull-down resistors. The options for object 2020h are shown in Table 9, with the default bolded.

Value	Meaning
<b>0</b>	<b>Pullup/Down Disabled (high impedance input)</b>
1	10kΩ Pullup Resistor Enabled
2	10kΩ Pulldown Resistor Enabled

**Table 9 – DI Pullup/Down Options**

Figure 6 shows the hysteresis on the input when switching a discrete signal. A digital input can be switched up to +Vcc (42Vmax.)

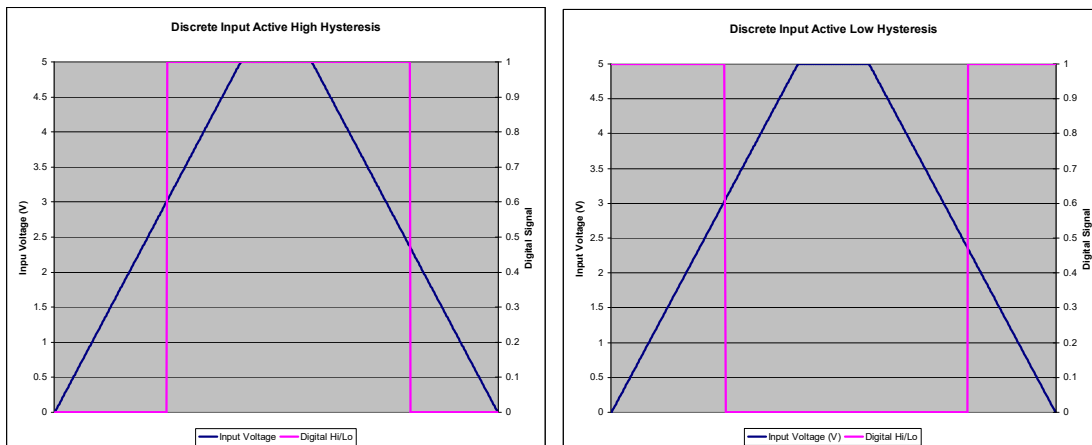

**Figure 6 – Discrete Input Hysteresis**

Once the raw state has been evaluated, the logical state of the input is determined by object 6002h **DI\_Polarity\_8\_Input\_Lines**. The options for object 6002h are shown in Table 10. The state of the DI will be written to read-only object 6000h **DI\_Read\_state\_8\_Input\_Lines**. By default, normal on/off logic is used.

Value	Meaning
0	Normal On/Off
1	Inverse On/Off

**Table 10 – Object 6002h DI Polarity 8 Input Lines Options**

The format to write to object 6002h is as follows:

Sub-index 1 will determine the following inputs polarities

Bit 7	Bit 6	Bit 5	Bit 4	Bit 3	Bit 2	Bit 1	Bit 0
-	-	-	-	-	-	UI2	UI1

The rest of the bits in sub-index 1 will be ignored.

As per the format of object 6002h, the bits in object 6000h **DI\_Read\_state\_8\_Input\_Lines** will be written to represent the same inputs' states.

There is another type of 'digital' input that can be selected when 6112h is set to 20 = Analog On/Off. However, in this case, the input is still configured as an analog input, and therefore the objects from the Analog Input (AI) block are applied instead of those discussed above. Here, objects 2020h, 2030h and 6030h are ignored, and 6000h is written as per the logic shown in Figure 7. In this case, the MIN parameter is set by object 7120h **AI Scaling 1 FV**, and the MAX is set by 7122h **AI Scaling 2 FV**. For all other operating modes, object 6000h will always be zero.

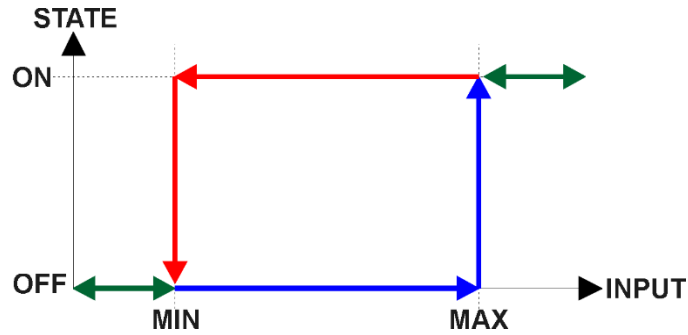

Figure 7 – Analog Input Reads as Digital

## 2.2. Output Function Blocks

The controller has eight signal outputs, capable of producing both voltage and current signals. The available voltage modes include both positive and negative voltages. In addition to output type configuration, user can select control, enable and override sources for each output. Also fault mode functionality can be configured.

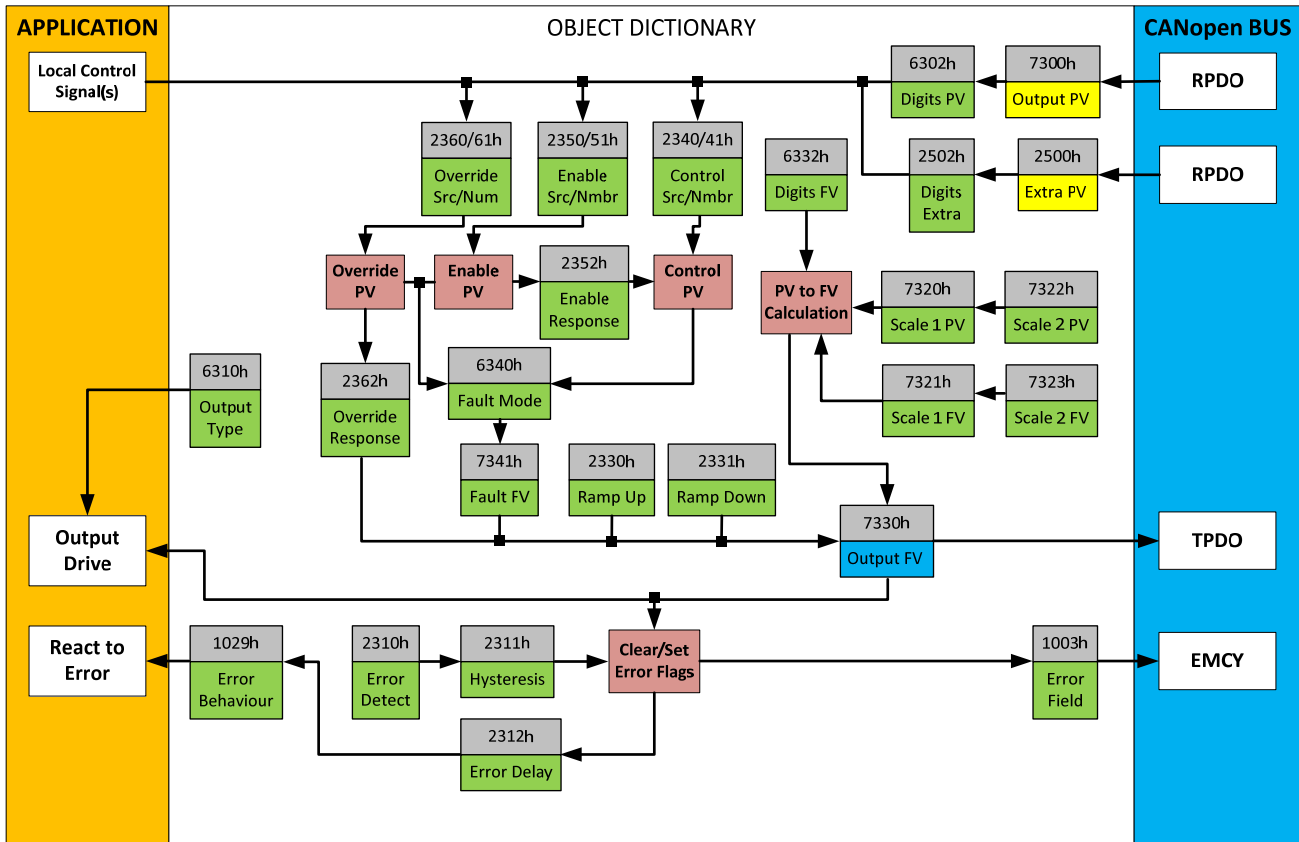

Figure 8 – Analog Output Objects

Together Objects 6310h **AO Output Type** and 2302h **AO Output Range** define how the output drive circuitry will be configured. Options for object 6310h **AO Output Type** are shown in Table 9. This table also shows the output unit and range for each type. By default, analog outputs are configured as voltage outputs.

Value	Meaning
0	Output Disabled
10	Output Voltage
20	Output Current

**Table 11 – Object 6310h AO Output Type Options**

The allowable ranges will depend on the output type selected. Table 3 shows the relationship between the output type, and the associated range options. The default value for each range is bolded, and object 2302h **AO Output Range** will automatically be updated with this value when 6310h is changed. The grayed cells mean that the associate value is not allowed for the range object when that output type has been selected.

Value	Voltage	Current
0	<b>0 to 5V</b>	<b>0 to 20mA</b>
1	0 to 10V	4 to 20mA
2	-5 to 5V	
3	-10 to 10V	

**Table 12 – AO Output Range Options Depending on Output Type**

When the output type is changed, all objects related to the output (scaling PV, Decimal Digits PV, etc) are automatically updated by default. Object 5550h enables/disables automatic updates. When disabled (set to False), the objects are to be manually configured.

Sensor Type/ Input Range	7320h AO Scaling 1 FV (i.e. Input Min)	7322h AO Scaling 2 FV (i.e. Input Max)	2300h AO Override Field Value	7341h AO Fault Field Value	6332h AO Decimal Digits FV
Voltage: 0 to 5V	0 [mV]	5000 [mV]	5000 [mV]	0 [mV]	3 [mV]
Voltage: 0 to 10V	0 [mV]	10000 [mV]	10000 [mV]	0 [mV]	3 [mV]
Voltage: -5 to 5V	-5000 [mV]	5000 [mV]	5000 [mV]	0 [mV]	3 [mV]
Voltage: -10 to 10V	-10000 [mV]	10000 [mV]	10000 [mV]	0 [mV]	3 [mV]
Current: 0 to 20mA	0 [uA]	20000 [uA]	20000 [uA]	0 [uA]	3 [uA]
Current: 4 to 20mA	4000 [uA]	20000 [uA]	20000 [uA]	4000 [uA]	3 [uA]

**Table 13 – AO Object Defaults Based on Output Type and Input Range**

The relationship between the Process Value (input) and the Field Value (output) is a linear one, as shown in Figure 8. However, the output will use the AO Scaling FV objects as limits to the drive, such that the output will hold at the minimum and maximum FV points, as shown in the figure.

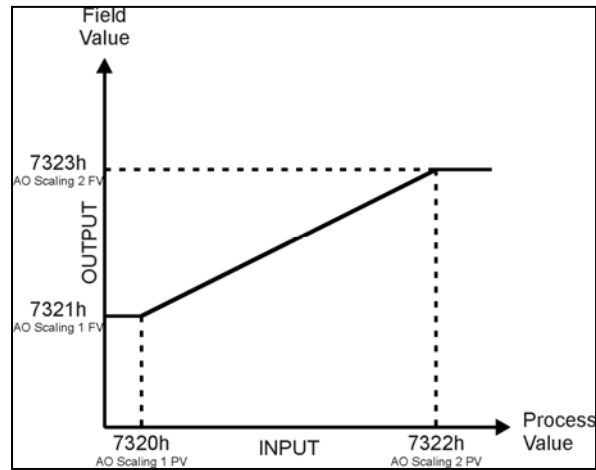

**Figure 9 – Analog Output Linear Scaling PV to FV**

The 12IN-8SOUT-CO controller allows for the PV input to be selected from the list of the logical function blocks supported by the controller. As a result, any output from one function block can be selected as the control source for another. Keep in mind that not all options make sense in all cases, but the complete list of control sources is shown in Table 23. By default, analog outputs are setup to respond to the corresponding CANopen RPDO message.

There are three inputs to the output function block, each one with a unique source and number object. For the control function (PV axis in Figure 9) objects 2340h **AO Control Input Source** and 2341h **AO Control Input Number** are used. For the enable function, objects 2350h **AO Enable Input Source** and 2351h **AO Enable Input Number** are used. Lastly, for the override function, objects 2360h **AO Override Input Source** and 2361h **AO Override Input Number** are used.

The output can be set to a custom FV value when output is disabled, either by Enable source being zero or module state being not Operational, using object 2353h **AO Disable Drive FV**.

### 2.2.1. Relay Output

The controller has one Relay output. The Relay is driven by the CPU. The Normally Closed, Normally Open and COMmon pins of the relay are available in the 8 pin Deutsch connector.

The Relay is capable of handling 5A/250VAC.

### 2.2.2. Reference Voltages

The controller has two user configurable reference voltage outputs. By default, with No Control Source or the Control Source value set to 0, the Reference Voltage is set to 10V.

When a 5V reference is used, the 5120h **VREF Control Source** and 5121h **VREF Control Number** objects for the reference voltage need to have a non-zero value. For example, setting the “**VRef #1 Control Source**” to “7 – Control Constant Data” and “**VRef #1 Control Number**” to “2 – Control Constant Data #2” will configure the reference voltage source #1 as a 5V reference.

### 2.3. PID Function Block

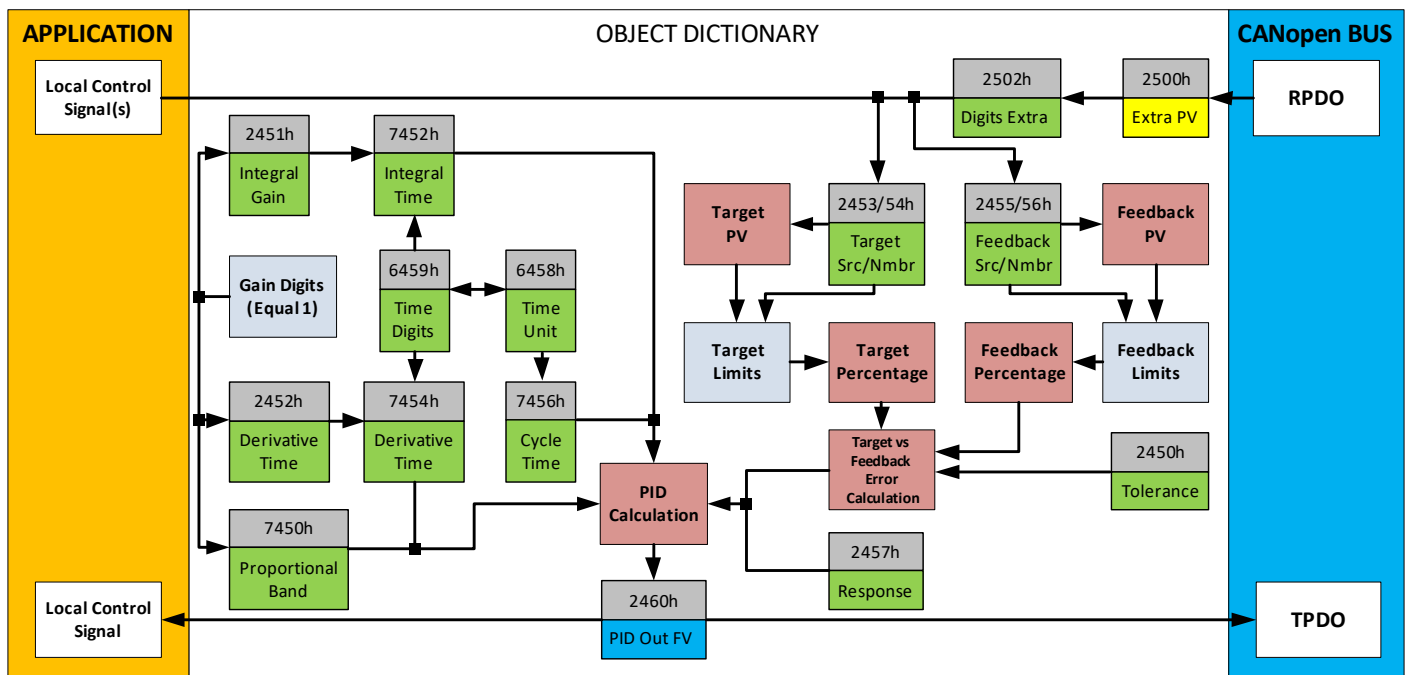

Figure 10 – PID Control Objects

As with the output function block, the PID control function has control inputs associate with it that can be mapped to the output from any other function block. Objects 2453h **PID Target Source** and 2454h **PID Target Number** define what value the PID loop will attempt to maintain. For example, in the case of a setpoint (fixed) control application, this input can be mapped to one of object 5010h, a Constant FV. In this case, since there is no pre-defined range associated with a constant, the scaling limits will be set equal to those of the feedback input. Otherwise, the target input units do not have to match the feedback units, so long as they are scaled relative to one another.

Objects 2355h **PID Feedback Source** and 2356h **PID Feedback Number** define the close-loop input. Both the target and feedback use Table 23 as the available options. Both inputs are normalized to a percentage based on the associated scaling limits as defined in Table 24.

Object 2450h **PID Tolerance** defines the acceptable difference between the target and feedback, as a percentage, whereby an absolute difference smaller than this is treated as a 0% error.

Unless both the target and feedback inputs have legitimate control sources selected, the PID loop is disabled. When active, however, the PID algorithm will be called every 7456h **PID Cycle Time**, the default being every 10ms.

Object 6458h **PID Physical Unit Timing** is a read-only value and is defined in Seconds. The default value for object 6459h **PID Decimal Digits Timing** is 3, which means the object 7456h, along with other PID timing objects, are interpreted in milliseconds. Other time objects associated with the PID control are 7452h **PID Integral Action Time (Ti)** and 7454h **PID Derivative Action Time (Td)**.

No time related objects use a fixed resolution of 1 decimal digit. These objects include 7450h PID Proportional Band (G), 2450h PID Tolerance, 2451h PID Integral Gain (Ki), and 2454h PID Derivative Gain (Kd).

By default, the PID loop is assumed to be controlling a single output which will increase/decrease as the feedback over/undershoots the target. However, some systems may require a push-pull response where one output comes on when over target, and the other when under. Object 2457h PID Control Response allows the user to select the response profile as needed from Table 14.

Value	Meaning
0	Single Output
1	On When Over Target
2	On When Below Target

**Table 14 – PID Control Response Options**

The PID algorithm used is shown below, with names in red being the object variables. The result PIDOutput<sub>k</sub> is written to the read-only mappable object 2460h **PID Output Field Value** and is interpreted as a percentage value with 1 decimal place resolution. It can be used as the control source for another function block, i.e. one of the analog outputs.

```

T = Loop_Update_Rate*0.001

P_Gain = G
I_Gain = Ki*T/Ti
D_Gain = Kd*T/Td
Note: If Ti is zero, I_Gain = 0

Errork = Target - Feedback

ErrorSumk = ErrorSumk-1 + Errork

Pk = Errork * P_Gain

Ik = ErrorSumk * I_Gain

Dk = (Errork-Errork-1) * D_Gain

PIDOutputk = Pk + Ik + Dk

```

**Figure 11 – PID Control Algorithm**

Each system will have to be tuned for the optimum output response. Response times, overshoots and other variables will have to be decided by the customer using an appropriate PID tuning strategy.

## 2.4. Lookup Table Function Block

The lookup table (LTz) function blocks are not used by default.

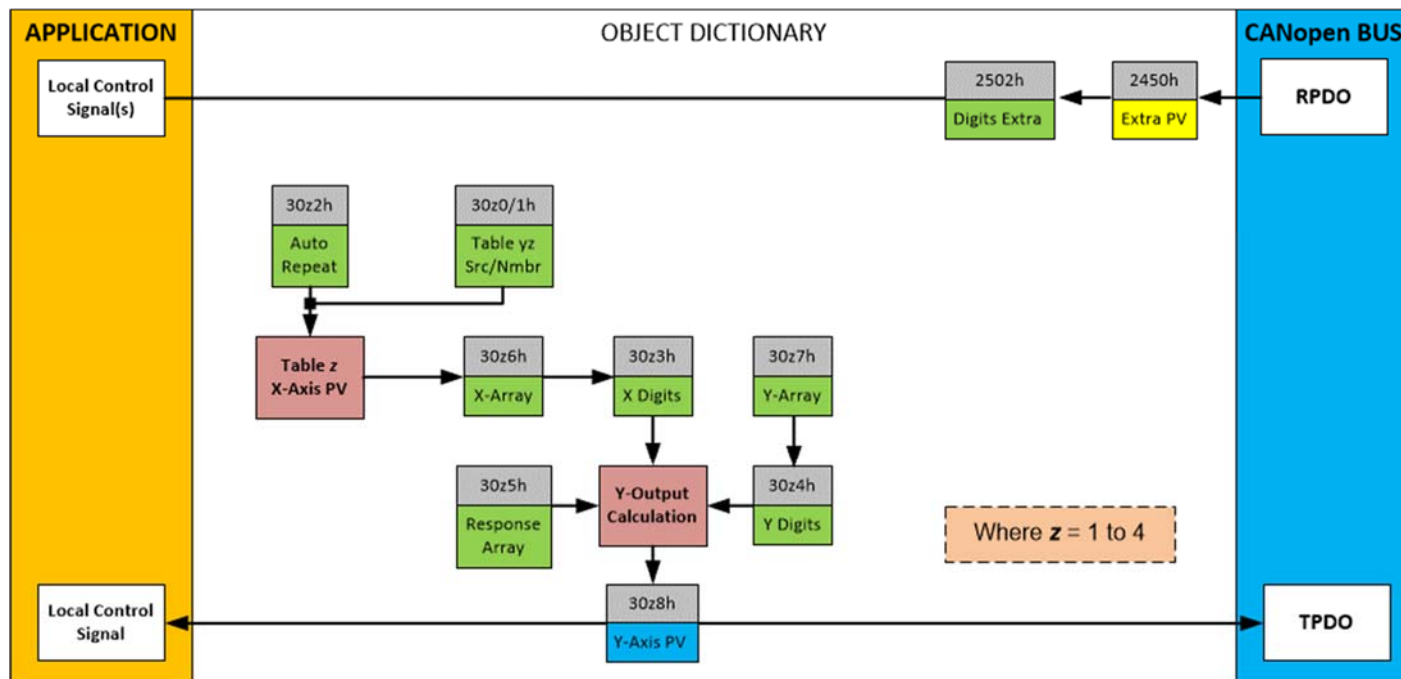

Figure 12 – Lookup Table Objects

**Lookup tables are used to give an output response of up to 10 slopes per input.** The array size of the objects 30z5h **LT0z Point Response**, 30z6h **LT0z Point X-Axis PV** and 30z7h **Point Y-Axis PV** shown in the block diagram above is therefore 11.

Note: If more than 10 slopes are required, a Programmable Logic Block can be used to combine up to three tables to get 30 slopes, as is described in Section 0.

A parameter that will affect the function block is object **30z5h sub-index 1** which defines the “**X-Axis Type**”. By default, the tables have a ‘*Data Response*’ output (0). Alternatively, it can be selected as a ‘*Time Response*’ (1).

There are two (or three) other key parameters that will affect how this function block will behave depending on the “**X-Axis Type**” chosen. If chosen ‘*Data Response*’, then the objects 30z0h **Lookup Table z Input X-Axis Source** and 30z1h **Lookup Table z Input X-Axis Number** together define the control source for the function block. When it is changed, the table values in object 30z6h need to be updated with new defaults based on the X-Axis source selected as described in Tables 15 and 16. If however, the “**X-Axis Type**” is chosen to be ‘*Time Response*’, an additional parameter is taken into consideration - object 30z2h, **Lookup Table z Auto Repeat**. These will be described in more detail in Section 2.4.4.

### 2.4.1. X-Axis, Input Data Response

In the case where the “**X-Axis Type**” = ‘*Data Response*’, the points on the X-Axis represents the data of the control source.

The constraint on the X-Axis data is that the next index value is greater than or equal to the one below it, as shown in the equation below. Therefore, when adjusting the X-Axis data, it is recommended that  $X_{11}$  is changed first, then lower indexes in descending order.

$$\text{MinInputRange} \leq X_1 \leq X_2 \leq X_3 \leq X_4 \leq X_5 \leq X_6 \leq X_7 \leq X_8 \leq X_9 \leq X_{10} \leq X_{11} \leq \text{MaxInputRange}$$

As stated earlier, MinInputRange and MaxInputRange will be determined by the scaling objects associated with X-Axis Source that has been selected, as outlined in Table 24.

### 2.4.2. Y-Axis, Lookup Table Output

By default, it is assumed that the output from the lookup table function block will be a percentage value in the range of 0 to 100.

In fact, so long as all the data in the Y-Axis is  $0 \leq Y[i] \leq 100$  (where  $i = 1$  to  $11$ ) then other function blocks using the lookup table as a control source will have 0 and 100 as the Scaling 1 and Scaling 2 values used in linear calculations shown in Table 24.

However, the Y-Axis has no constraints on the data that it represents. This means that inverse or increasing/decreasing or other responses can be easily established. The Y-Axis does not have to be a percentage output but could represent full scale process values instead.

In all cases, the controller looks at the entire range of the data in the Y-Axis sub-indexes and selects the lowest value as the MinOutRange and the highest value as the MaxOutRange. So long as they are not both within the 0 to 100 range, they are passed directly to other function blocks as the limits on the lookup table output. (i.e. Scaling 1 and Scaling 2 values in linear calculations.)

Even if some of the data points are ‘*Ignored*’ as described in Section 2.4.3, they are still used in the Y-Axis range determination. If not all the data points are going to be used, it is recommended that Y10 be set to the minimum end of the range, and Y11 to the maximum first. This way, the user can get predictable results when using the table to drive another function block, such as an analog output.

### 2.4.3. Point to Point Response

By default, all six lookup tables have a simple linear response from 0 to 100 in steps of 10 for both the X and Y axes. For a smooth linear response, each point in the 30z5h **LTz Point Response** array is setup for a ‘*Ramp To*’ output.

Alternatively, the user could select a ‘*Step To*’ response for 30z4h, where  $N = 2$  to  $11$ . In this case, any input value between  $X_{N-1}$  to  $X_N$  will result in an output from the lookup table function block of  $Y_N$ . (Recall: *LTz Point Response sub-index 1 defines the X-Axis type*)

Figure 13 shows the difference between these two response profiles with the default settings.

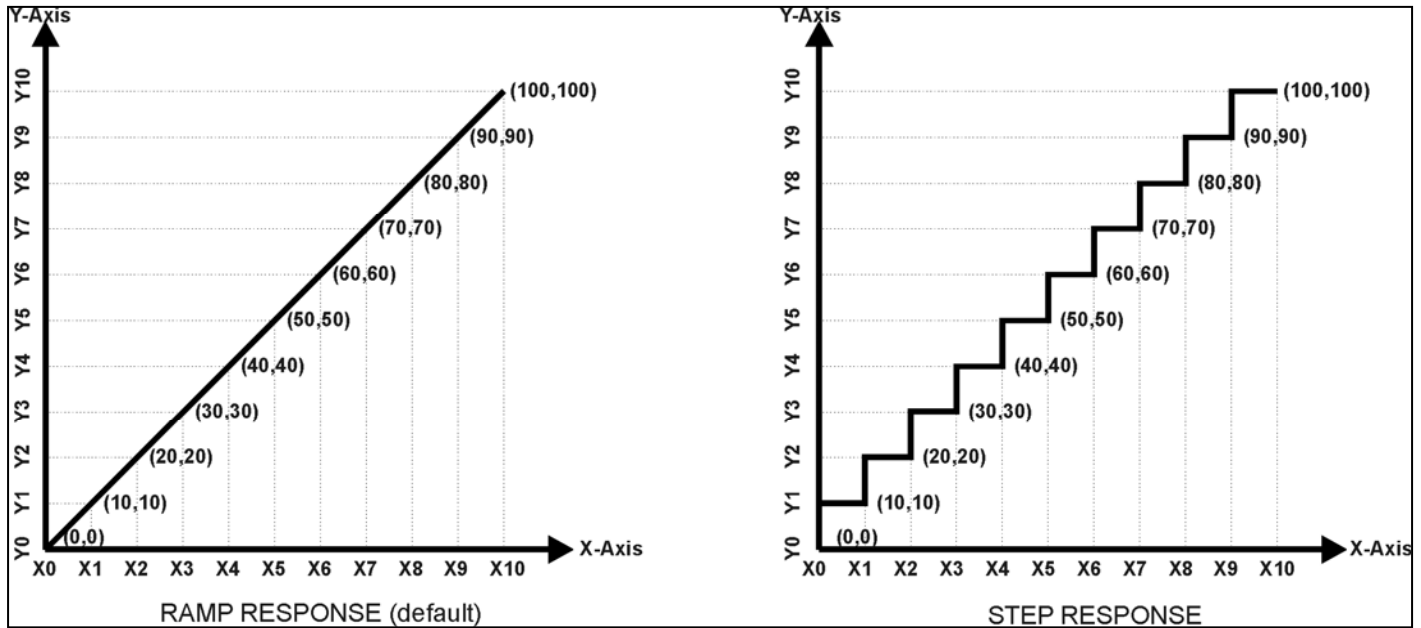

**Figure 13 – Lookup Table Defaults with Ramp and Step Responses**

Lastly, any point except (1,1) can be selected for an 'Ignore' response. If **LTz Point Response sub-index N** is set to ignore, then all points from  $(X_N, Y_N)$  to  $(X_{11}, Y_{11})$  will also be ignored. For all data greater than  $X_{N-1}$ , the output from the lookup table function block will be  $Y_{N-1}$ .

A combination of 'Ramp To', 'Jump To' and 'Ignore' responses can be used to create an application specific output profile. An example of where the same input is used as the X-Axis for two tables, but where the output profiles 'mirror' each other for a deadband joystick response is shown in Figure 14. The example shows a dual slope percentage output response for each side of the deadband, but additional slopes can be easily added as needed. (Note: In this case, since the analog outputs are responding directly to the profile from the lookup tables, both would have object 2342h AO Control Response set to a 'Single Output Profile.')

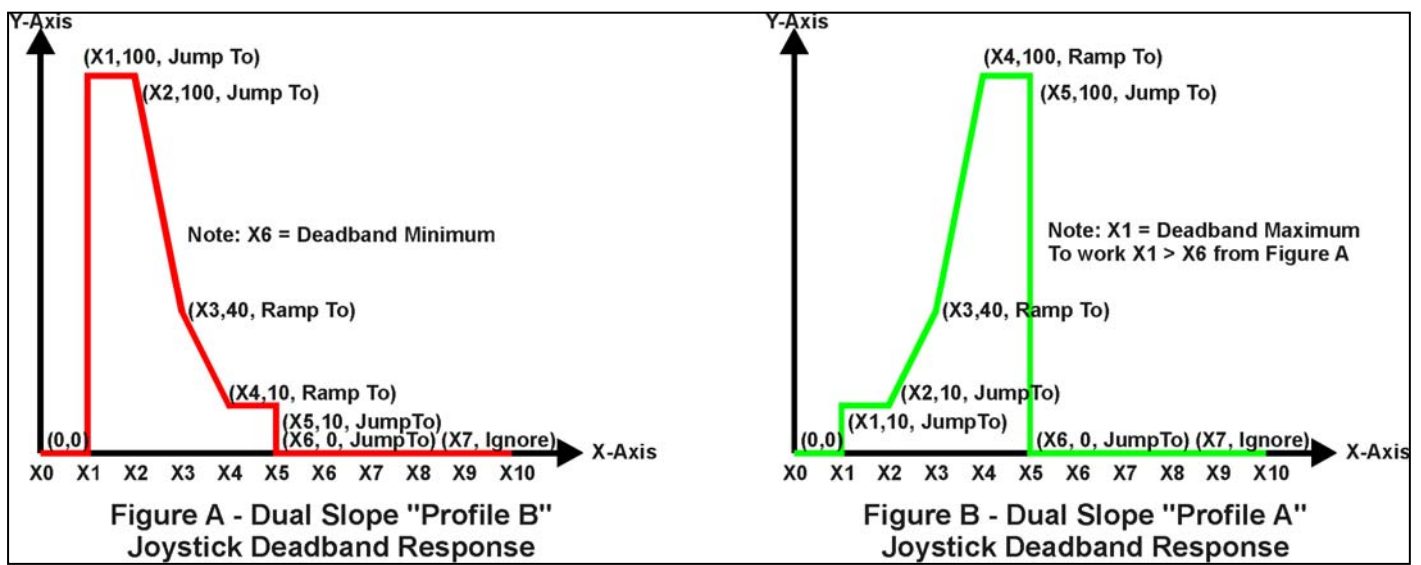

**Figure 14 – Lookup Table Examples to Setup for Dual-Slope Joystick Deadband Response**

To summarize, Table 15 outlines the different responses that can be selected for object 30z4h, both for the X-Axis type and for each point in the table.

Sub-Index	Value	Meaning
1	0	Data Response (X-Axis Type)
2 to 11		Ignore (this point and all following it)
1	1	Time Response (X-Axis Type)
2 to 11		Ramp To (this point)
1	2	N/A (not an allowed option)
2 to 11		Jump To (this point)

**Table 15 – LTyz Point Response Options**

#### 2.4.4. X-Axis, Time Response

A lookup table can also be used to get a custom output response where the “**X-Axis Type**” is a ‘*Time Response*’. When this is selected, the X-Axis now represents time, in units of milliseconds, while the Y-Axis still represents the output of the function block.

With this response, the sequence will start depending on two parameters:

- **Lookup Table z Input X-Axis Source** Object 30z0h and;
- **Lookup Table z Auto Repeat** Object 30z2h

By default, the “Auto Repeat” object is set to FALSE (0). In this case, the lookup table will react in the following way:

The X-Axis control source is treated as a digital input. When the control input is ON, the output will be changed over a period of time based on the profile in the lookup table. Once the profile has finished (i.e. reached index 11, or an ‘Ignored’ response), the output will remain at the last output at the end of the profile until the control input turns OFF.

**However**, when the “Auto Repeat” object is set to TRUE (1), the lookup table will react in the following way:

When the control input is ON, the output will be changed over a period of time based on the profile in the lookup table. Once the profile has finished (i.e. reached index 11, or an ‘Ignored’ response), the lookup table will revert back to the first point in the table and Auto Repeat the sequence. This will continue for as long as the input remains ON. Once the input turns OFF, the lookup table sequence will stop and the output of the lookup table is zero.

**Note:** When the control input is OFF, the output is always at zero. When the input comes ON, the profile will **ALWAYS** start at position (X<sub>1</sub>, Y<sub>1</sub>) which is 0 output for 0ms.

In a time response, the data in object 30z6h **LT0z Point X-Axis PV** is measured in milliseconds, and object 30z3h **LT0z X-Axis Decimal Digits PV** is automatically set to 0. A minimum value of 1ms must be selected for all points other than sub-index 1 which is automatically set to [0,0]. The interval time between each point on the X-axis can be set anywhere from 1ms to 24 hours. [86,400,000 ms]

## 2.5. Programmable Logic Function Block

The programmable logic blocks (LB(x-3)) functions are not used by default.

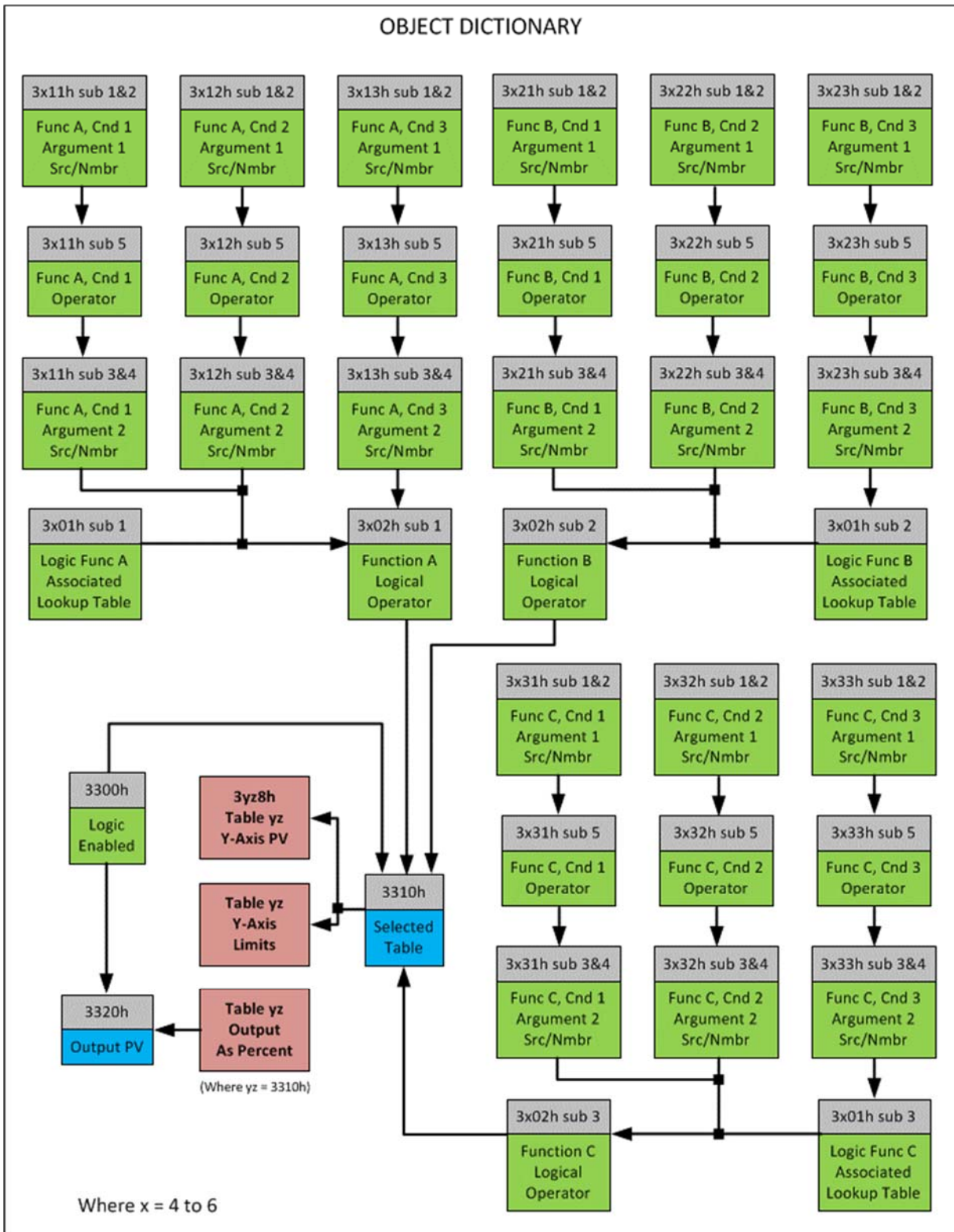

**Figure 15 – Logic Block Objects**

This function block is obviously the most complicated of them all, but very powerful. Any LB<sub>x</sub> (where X = 4 to 5) can be linked with up to three lookup tables, any one of which would be selected only under given conditions. Any three tables (of the available 6) can be associated with the logic, and which ones are used is fully configurable on object 3x01 LB(x-3) Lookup Table Number.

Should the conditions be such that a particular table (A, B or C) has been selected as described in Section 2.5.2, then the output from the selected table, at any given time, will be passed directly to LB(x-3)'s corresponding sub-index X in read-only mappable object 3320h Logic Block Output PV. The active table number can read from read-only object 3310h Logic Block Selected Table.

Note: In this document, the term LB(x-3) refers to Logic Blocks 1 to 2. Due to the CANopen Object indices, Logic Block 1 begins at 3401h where x, in this case, is 4.

Therefore, an LB<sub>x</sub> allows up to three different responses to the same input, or three different responses to different inputs, to become the control for another function block. Here, the "Control Source" for the reactive block would be selected to be the 'Programmable Logic Function Block,' as described in Section 2.5.2.

In order to enable any one of logic blocks, the corresponding sub-index in object 3300h Logic Block Enable must be set to TRUE. They are all disabled by default.

Logic is evaluated in the order shown in Figure 16. Only if a lower indexed table (A, B, C) has not been selected will the conditions for the next table be looked at. **The default table is always selected as soon as it is evaluated. It is therefore required that the default table always be the highest index in any configuration.**

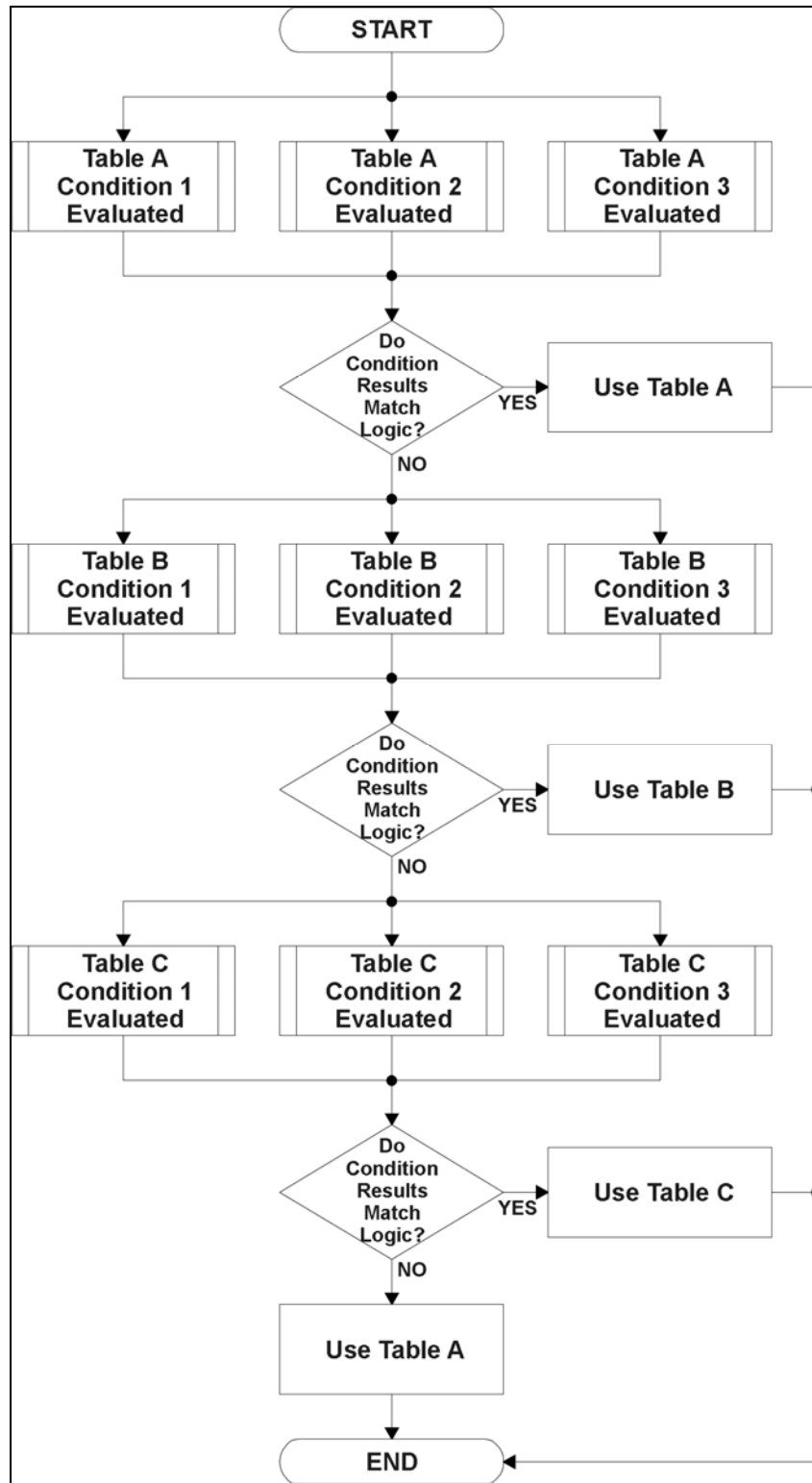

**Figure 16 – Logic Block Flowchart**

### 2.5.1. Conditions Evaluation

The first step in determining which table will be selected as the active table is to first evaluate the conditions associated with a given table. Each table has associated with it up to three conditions that can be evaluated. Conditional objects are custom DEFSTRUCT objects defined as shown in Table 15.

Index	Sub-Index	Name	Data Type
3xyz*	0	Highest sub-index supported	UNSIGNED8
	1	Argument 1 Source	UNSIGNED8
	2	Argument 1 Number	UNSIGNED8
	3	Argument 2 Source	UNSIGNED8
	4	Argument 2 Number	UNSIGNED8
	5	Operator	UNSIGNED8

\* Logic Block X Function Y Condition Z, where X = 4 to 7, Y = A, B or C, and Z = 1 to 3

**Table 16 – LB(x-3) Condition Structure Definition**

Objects 3x11h, 3x12h and 3x13h are the conditions evaluated for selecting Table A. Objects 3x21h, 3x22h and 3x23h are the conditions evaluated for selecting Table B. Objects 3x31h, 3x32h and 3x33h are the conditions evaluated for selecting Table C.

Argument 1 is always a logical output from another function block, as listed in Table 18. As always, the input is a combination of the functional block objects 3xyzh sub-index 1 “**Argument 1 Source**” and “**Argument 1 Number.**”

Argument 2 on the other hand, could either be another logical output such as with Argument 1, OR a constant value set by the user. To use a constant as the second argument in the operation, set “**Argument 2 Source**” to ‘Constant Function Block’, and “**Argument 2 Number**” to the desired sub-index. When defining the constant, make sure it uses the same resolution (decimal digits) as the Argument 1 input.

Argument 1 is evaluated against Argument 2 based on the “**Operator**” selected in sub-index 5 of the condition object. The options for the operator are listed in Table 17, and the default value is always ‘Equal’ for all condition objects.

Value	Meaning
0	=, Equal
1	!=, Not Equal
2	>, Greater Than
3	>=, Greater Than or Equal
4	<, Less Than
5	<=, Less Than or Equal

**Table 17 – LB(x-3) Condition Operator Options**

By default, both arguments are set to ‘Control Source Not Used’ which disables the condition, and automatically results in a value of N/A as the result. Although is generally considered that each condition will be evaluated as either TRUE or FALSE, the reality is that there could be four possible results, as described in Table 18.

Value	Meaning	Reason
0	False	(Argument 1) Operator (Argument 2) = False
1	True	(Argument 1) Operator (Argument 2) = True
2	Error	Argument 1 or 2 output was reported as being in an error state
3	Not Applicable	Argument 1 or 2 is not available (i.e. set to 'Control Source Not Used')

**Table 18 – LB(x-3) Condition Evaluation Results**

### 2.5.2. Table Selection

In order to, determine if a particular table will be selected, logical operations are performed on the results of the conditions as determined by the logic in Section 0. There are several logical combinations that can be selected, as listed in Table 19. The default value for object 3x02h **LB(x-3) Function Logical Operator** is dependent on the sub-index. For sub-index 1 (Table A) and 2 (Table B), the 'Cnd1 And Cnd2 And Cnd3' operator is used, whereas sub-index 3 (Table C) is setup as the 'Default Table' response.

Value	Meaning
0	Default Table
1	Cnd1 And Cnd2 And Cnd3
2	Cnd1 Or Cnd2 Or Cnd3
3	(Cnd1 And Cnd2) Or Cnd3
4	(Cnd1 Or Cnd2) And Cnd3

**Table 19 – LB(x-3) Function Logical Operator Options**

Not every evaluation is going to need all three conditions. The case given in the earlier section, for example, only has one condition listed, i.e. that the Engine RPM be below a certain value. Therefore, it is important to understand how the logical operators would evaluate an Error or N/A result for a condition, as outlined in Table 20.

Logical Operator	Select Conditions Criteria
Default Table	Associated table is automatically selected as soon as it is evaluated.
Cnd1 And Cnd2 And Cnd3	<p><b>Should be used when two or three conditions are relevant, and all must be True to select the table.</b></p> <p>If any condition equals False or Error, the table is not selected. An N/A is treated like a True. If all three conditions are True (or N/A), the table is selected.</p> <p>If((Cnd1==True) &amp;&amp;(Cnd2==True)&amp;&amp;(Cnd3==True)) Then Use Table</p>
Cnd1 Or Cnd2 Or Cnd3	<p><b>Should be used when only one condition is relevant. Can also be used with two or three relevant conditions.</b></p> <p>If any condition is evaluated as True, the table is selected. Error or N/A results are treated as False</p> <p>If((Cnd1==True)    (Cnd2==True)    (Cnd3==True)) Then Use Table</p>
(Cnd1 And Cnd2) Or Cnd3	<p><b>To be used only when all three conditions are relevant.</b></p> <p>If both Condition 1 and Condition 2 are True, OR Condition 3 is True, the table is selected. Error or N/A results are treated as False</p> <p>If( ((Cnd1==True)&amp;&amp;(Cnd2==True))    (Cnd3==True) ) Then Use Table</p>
(Cnd1 Or Cnd2) And Cnd3	<p><b>To be used only when all three conditions are relevant.</b></p> <p>If Condition 1 And Condition 3 are True, OR Condition 2 And Condition 3 are True, the table is selected. Error or N/A results are treated as False</p> <p>If( ((Cnd1==True)  ((Cnd2==True)) &amp;&amp; (Cnd3==True) ) Then Use Table</p>

**Table 20 – LB(x-3) Conditions Evaluation Based on Selected Logical Operator**

If the result of the function logic is TRUE, then the associated lookup table (see object 4x01h) is immediately selected as the source for the logic output. No further conditions for other tables are evaluated. For this reason, the 'Default Table' should always be setup as the highest letter table being used (A, B or C). If no default response has been setup, the Table A automatically becomes the default when no conditions are true for any table to be selected. This scenario should be avoided whenever possible to not result in unpredictable output responses.

The table number that has been selected as the output source is written to sub-index X of read-only object 4010h **Logic Block Selected Table**. This will change as different conditions result in different tables being used.

### 2.5.3. Logic Block Output

Recall that Table Y, where Y = A, B or C in the LB(x-3) function block does NOT mean lookup table 1 to 3. Each table has object 3x01h LB(x-3) **Lookup Table Number** which allows the user to select which lookup tables they want associated with a particular logic block. The default tables associated with each logic block are listed in Table 21.

<b>Programmable Logic Block Number</b>	<b>Table A – Lookup Table Block Number</b>	<b>Table B – Lookup Table Block Number</b>	<b>Table C – Lookup Table Block Number</b>
1	1	2	3
2	4	4	4

**Table 21 – LB(x-3) Default Lookup Tables**

If the associated Lookup Table YZ (where YZ equals 3310h sub-index X) does not have an “**X-Axis Source**” selected, then the output of LB(x-3) will always be “Not Available” so long as that table is selected. However, should LT0z be configured for a valid response to an input, be it Data or Time, the output of the LT0z function block (i.e. the Y-Axis data that has been selected based on the X-Axis value) will become the output of the LB(x-3) function block so long as that table is selected.

The LB(x-3) output is always setup as a percentage, based on the range of the Y-Axis for the associated table (see Section 2.4.2) It is written to sub-index X of read-only object 3320h **Logic Block Output PV** with a resolution of 1 decimal place.

## 2.6. Math Function Block

There are two mathematic function blocks that allow the user to define basic algorithms. Math function block Z = 1 to 2 will be enabled based on sub-index Z in object 4000h **Math Enable**.

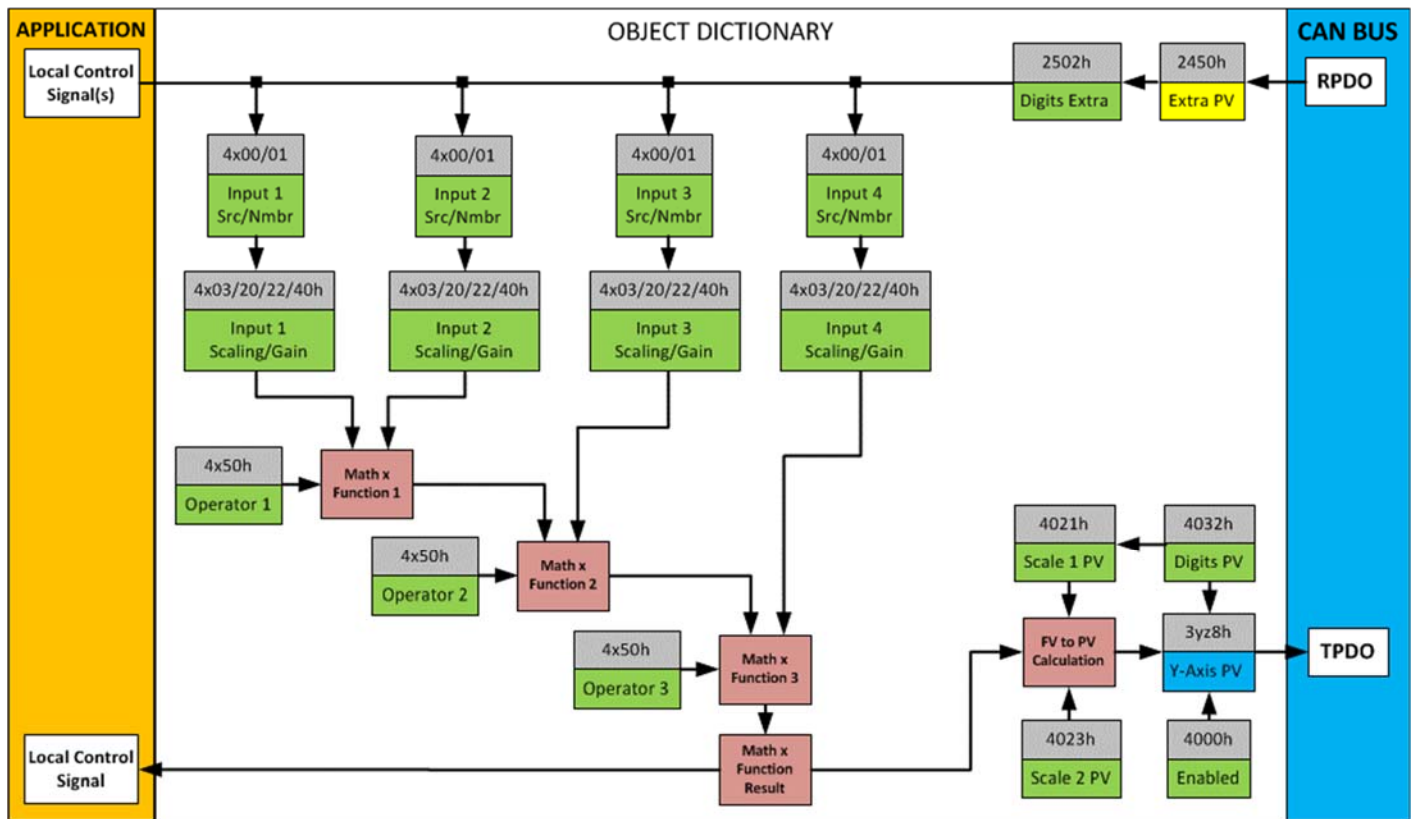

**Figure 17 – Math Function Block Objects**

A math function block can take up to four input signals, as listed in Table 23. Each input is then scaled according to the associated scaling and gain objects. A “Math Input X” is determined by the corresponding sub-index X = 1 to 2 of the objects 4y00h **Math Y Input Source** and 4y01h **Math Y Input Number**. Here, y = 1 to 2; corresponding to Math #1 - Math #2.

Inputs are converted into a percentage value based on objects 4y20h **Math Y Scaling 1 FV** and 4y22h **Math Y Scaling 2 FV**. Before being used in the calculation, these objects apply the resolution shift defined by object 4y02h **Math Y Decimal Digits FV**. As with any other function block using a control source for the X-Axis in a conversion, the scaling objects should be selected to match the values in the control’s corresponding objects as per Table 24.

For additional flexibility, the user can also adjust object 4y40h **Math Y Input Gain**. This object has a fixed decimal digit resolution of 2, and a range of -100 to 100. By default, each input has a gain of 1.0.

For each input pair, the appropriate arithmetic or logical operation is performed on the two inputs, InA and InB, according to the associated function in sub-index of InB in object 4y50h **Math Y Operator**. The list of selectable function operations is defined in Table 22.

0	=	True when InA Equals InB
1	!=	True when InA Not Equal InB
2	>	True when InA Greater Than InB
3	>=	True when InA Greater Than or Equal InB
4	<	True when InA Less Than InB
5	<=	True when InA Less Than or Equal InB
6	OR	True when InA or InB is True
7	AND	True when InA and InB are True
8	XOR	True when InA/InB is True, but not both
9	+	Result = InA plus InB
10	-	Result = InA minus InB
11	x	Result = InA times InB
12	/	Result = InA divided by InB
13	MIN	Result = Smallest of InA and InB
14	MAX	Result = Largest of InA and InB

**Table 22 – Object 4y50h Math Function Operators**

For Function 1, InA and InB are Math Inputs 1 and 2, respectively.

For Function 2, InA is the result of Function 2 and InB is Math Input 3, respectively.

For Function 3, InA is the result of Function 3 and InB is Math Input 4, respectively.

For a valid result in each Function, both inputs must be non-zero value (other than ‘Control Source Not Used’). Otherwise, the corresponding Function is ignored, and the “Output Data” for the math function block is the result of the earlier function scaled according to the output objects. For example, if Math Input 4 is not used, the math output would be the result of the Function 3 operation.

For logical operators (6 to 8), any SCALED input greater than or equal to 0.5 is treated as a TRUE input. For logic output operators (0 to 8), the result of the calculation for the function will always be 0 (FALSE) or 1 (TRUE).

Error data (i.e. input measured out of range) is always treated as a 0.0 input into the function.

For the arithmetic functions (9 to 14), it is recommended to scale the data such that the resulting operation will not exceed full scale (0 to 100%) and saturate the output result.

When dividing, a zero InB value will always result is a zero output value for the associated function. When subtracting, a negative result will always be treated as a zero, unless the function is multiplied by a negative one, or the inputs are scaled with a negative coefficient first.

The resulting final mathematical output calculation is in the appropriate physical units using object 4021h **Math Output Scaling 1 PV** and 4023h **Math Output Scaling 2 PV**. These objects are also considered the Min and Max values of the Math Block output and apply the resolution shift defined by object 4032h **Math Output Decimal Digits PV**. The result is written to read-only object 4030h **Math Output PV**. These scaling objects should also be taken into account when the Math Function is selected as the input source for another function block, as outlined in Table 24.

## 2.7. Miscellaneous Function Block

There are some other objects available which have not yet been discussed or mentioned briefly in passing (i.e. constants.) These objects are not necessarily associated with one another but are all discussed here.

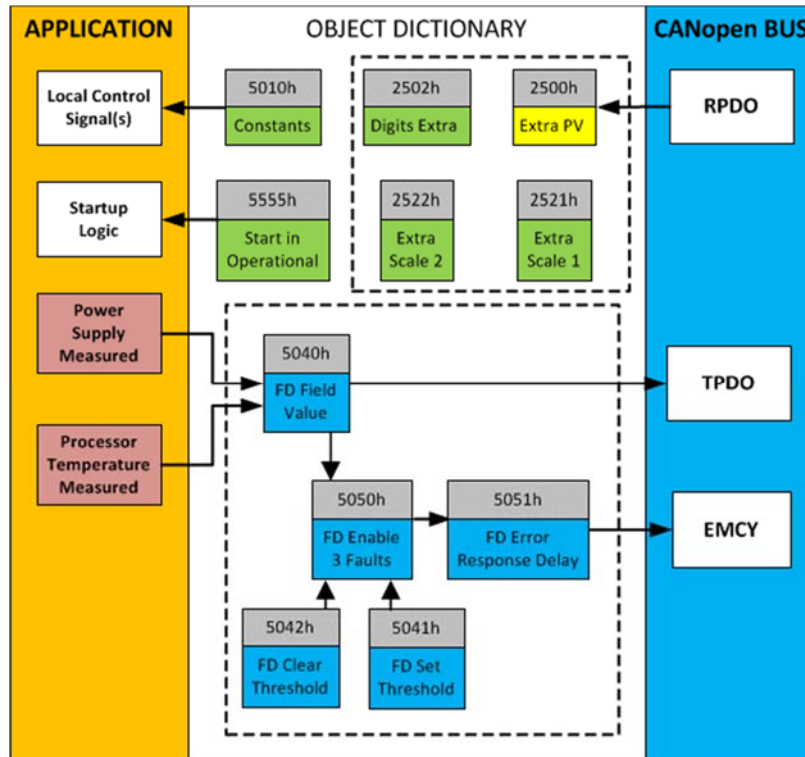

Figure 18 – Miscellaneous Objects

### Extra RPDO Messages

Objects 2500h **Extra Control Received PV**, 2502h **EC Decimal Digits PV**, 2502h **EC Scaling 1 PV** and **EC Scaling 2 PV** allow for additional data received on a CANopen® RPDO to be mapped independently to various function blocks as a control source. The scaling objects are provided to define the limits of the data when it is used by another function block, as shown in Table 24.

## Constant Values

Object 5010h **Constant Field Value** is provided to give the user the option for a fixed value that can be used by other function blocks. Sub-index 1 is fixed as FALSE (0) and sub-index 2 is always TRUE (1). There are 13 other sub-indexes provided for user selectable values.

The constants are read as 32-bit real (float) data, so no decimal digit object is provided. When setting up the constant, make sure to do it with the resolution of the object that will be compared with it.

The False/True constants are provided primarily to be used with the logic block. The variable constants are also useful with the logic or math blocks.

## Fault Detection Objects

Object 5040h **FD Field Value** is a read only object containing the field values of the over temperature, over and under voltage. Object 5041h **FD Set Threshold** sets the limit values for which the faults occur when reached. When any of these thresholds are reached, the faults will clear when the values have lowered to values set in object 5042h **FD Clear Threshold**.

For the 12IN-8SOUT-CO controller to begin monitoring fault detections, object 5050h **Error Check Detection** determines which Fault Detection is enabled through 1-byte data as bits. Once a fault is detected, object 5051h **Error Response Delay** will determine how long the fault needs to be present to flag and error.

## Startup

The object 5555h **Start in Operational** is provided as a 'cheat' when the unit is not intended to work with a CANopen network (i.e. a stand-alone control), or is working on a network comprised solely as slaves so the OPERATION command will never be received from a master. By default, this object is disabled (FALSE).

When using the 12IN-8SOUT-CO as a stand-alone controller where 5555h is set to TRUE, it is recommended to disable all TPDOs (set the Event Timer to zero) so that it does not run with a continuous CAN error when not connected to a bus.

## 2.8. Available Control Sources

Many of the Function Blocks have selectable input signals, which are determined with “[Name] Source” and “[Name] Number” objects. Together, these objects uniquely select how the I/O of the various function blocks are linked together. “[Name] Source” object determines the type of the source and “[Name] Number” selects the actual source if there is more than one of the same type. Available “[Name] Source” options and associated “[Name] Number” ranges are listed in Table 23. All sources, except “CAN message reception timeout”, are available for all blocks, including output control blocks and CAN Transmit messages. Thought input Sources are freely selectable, not all options would make sense for any input, and it is up to the user to program the controller in a logical and functional manner.

Sources	Number Range	Notes
<i>0: Control Not Used</i>	N/A	When this is selected, it disables all other setpoints associated with the signal in question.
<i>1: Received CAN Message</i>	1 to 18	First 9 are 7330h subindexes 1-9, the rest are read from 2500h, subindexes 1-9.
<i>2: Universal/Digital Input Measured</i>	1 to 12	
<i>3: PID Function Block</i>	1 to 2	User must enable the function block, as it is disabled by default.
<i>4: Lookup Table</i>	1 to 10	
<i>5: Programmable Logic Block</i>	1 to 2	User must enable the function block, as it is disabled by default.
<i>6: Math Function Block</i>	1 to 4	User must enable the function block, as it is disabled by default.
<i>7: Control Constant Data</i>	1 to 15	1 = FALSE, 2 = TRUE, 3 to 15 = User Selectable
<i>8: Diagnostic Trouble Code</i>	1 to 5	Will only be valid if the corresponding DTC has a non-zero SPN
<i>9: Output Target Drive</i>	1 to 9	Output drive target value.
<i>10: Measured Reference Voltage</i>	1 to 2	Measured reference voltage in Volts.
<i>11: Power Supply Measured</i>	0 to 255	Measured power supply value in Volts. The Parameter sets the threshold in Volts to compare with. In case Parameter is set to ‘0’, the measured value is used as is.
<i>12: Processor Temperature Measured</i>	0 to 255	Measured processor temperature in °C. The Parameter sets the threshold in Celcius to compare with. In case Parameter is set to ‘0’, the measured value is used as is.
<i>13: CAN Reception Timeout</i>	N/A	
<i>14: Control Variable Data</i>	N/A	Only available in J1939 version, AX030210
<i>15: DAC Status</i>	1 to 3	Signal Outputs’ DAC status. Number 3 reads ‘0’ if output fault is active.

**Table 23 – Available Control Sources and Numbers**

Control Source	Scaling 1	Scaling 2	Dec Digits
CANopen Message – Num 1 to 9	7320h	7322h	6302h
CANopen Message – Num 10 to 19	2520h	2522h	2502h
Constant Function Block	N/A	N/A	N/A (float)
PID Control Function Block	0%	100%	1 (fixed)
Lookup Table z Function Block (where z = 1 to 4)	0 or lowest from 30z6h <sup>(*)</sup>	100 or highest from 30z6h <sup>(**)</sup>	30z3h
Mathematical Function	4021h	4023h	4032h
Programmable Logic Function	0%	100%	1 (fixed)
Output Commanded Field Value	7320h	7322h	6302h
Power Supply Measured	N/A	N/A	1 (fixed)
Processor Temperature Measured	N/A	N/A	1 (fixed)

(\*) - Whichever value is smaller; (\*\*) - Whichever value is larger

**Table 24 – Scaling Limits per Control Source**

## 2.9. Diagnostics

There are fifteen built in CANopen EMCY messages available. The communications timeout, power supply voltage, CPU temperature (built-in temperature sensor) and out-of-range status for each of the inputs are monitored by the firmware.

If any of the variables are out of range, a corresponding CANopen EMY is sent.

EMCY Data	Meaning
0x 00 31 01 00 01 00 00 00	VPS out of range
0x 00 42 01 00 02 00 00 00	CPU temperature out of range
0x 10 F0 01 03 40 00 00 00	Input #1 out of range
0x 10 F0 01 04 41 00 00 00	Input #2 out of range
0x 10 F0 01 05 42 00 00 00	Input #3 out of range
0x 10 F0 01 06 43 00 00 00	Input #4 out of range
0x 10 F0 01 07 44 00 00 00	Input #5 out of range
0x 10 F0 01 08 45 00 00 00	Input #6 out of range
0x 10 F0 01 09 46 00 00 00	Input #7 out of range
0x 10 F0 01 0A 47 00 00 00	Input #8 out of range
0x 10 F0 01 0B 48 00 00 00	Input #9 out of range
0x 10 F0 01 0C 49 00 00 00	Input #10 out of range
0x 10 F0 01 0D 4A 00 00 00	Input #11 out of range
0x 10 F0 01 0E 4B 00 00 00	Input #12 out of range
0x 10 81 01 00 00 00 00 00	Communications error

**Table 25 – EMCY codes**

### 3. Installation Instructions

#### 3.1. Dimensions and Pinout

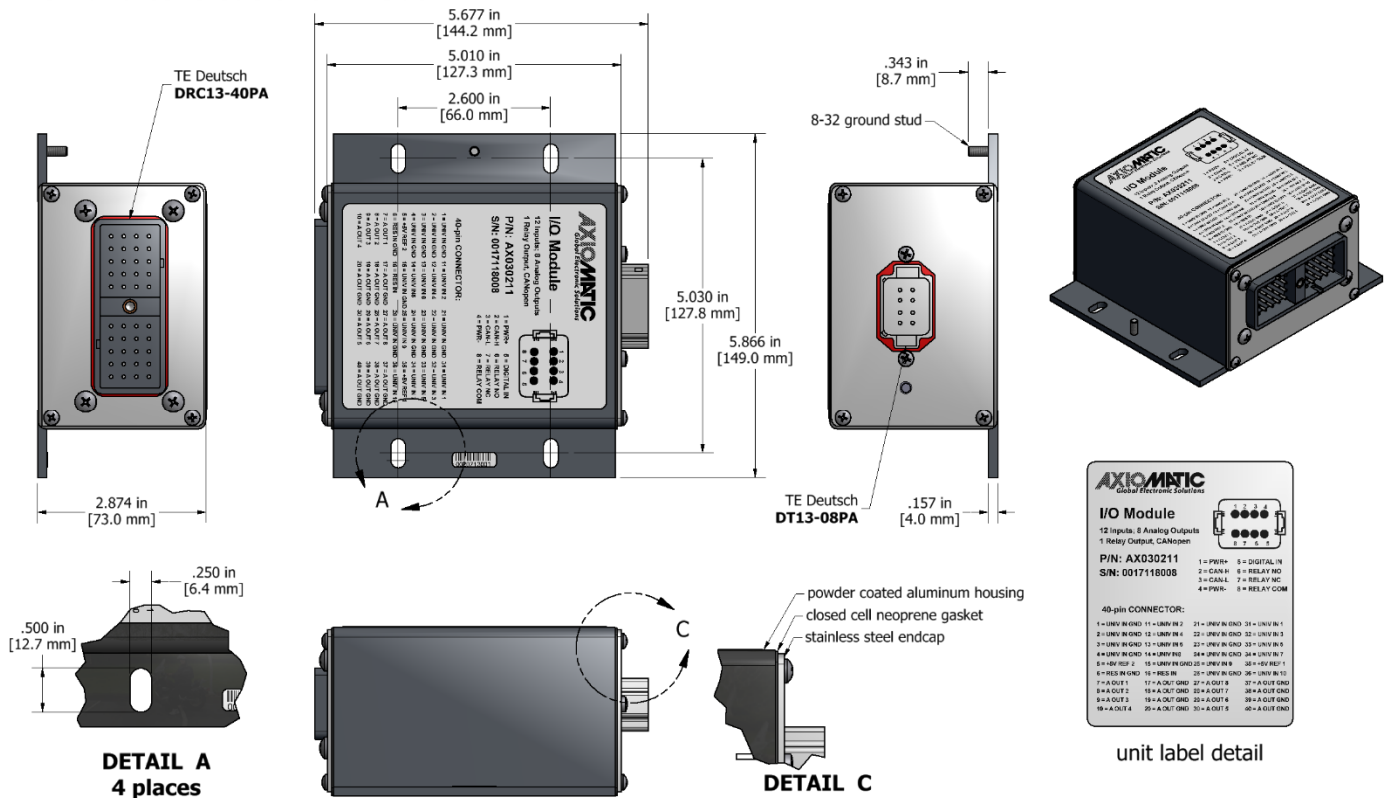

Figure 19 – AX030211 Dimensional Drawing

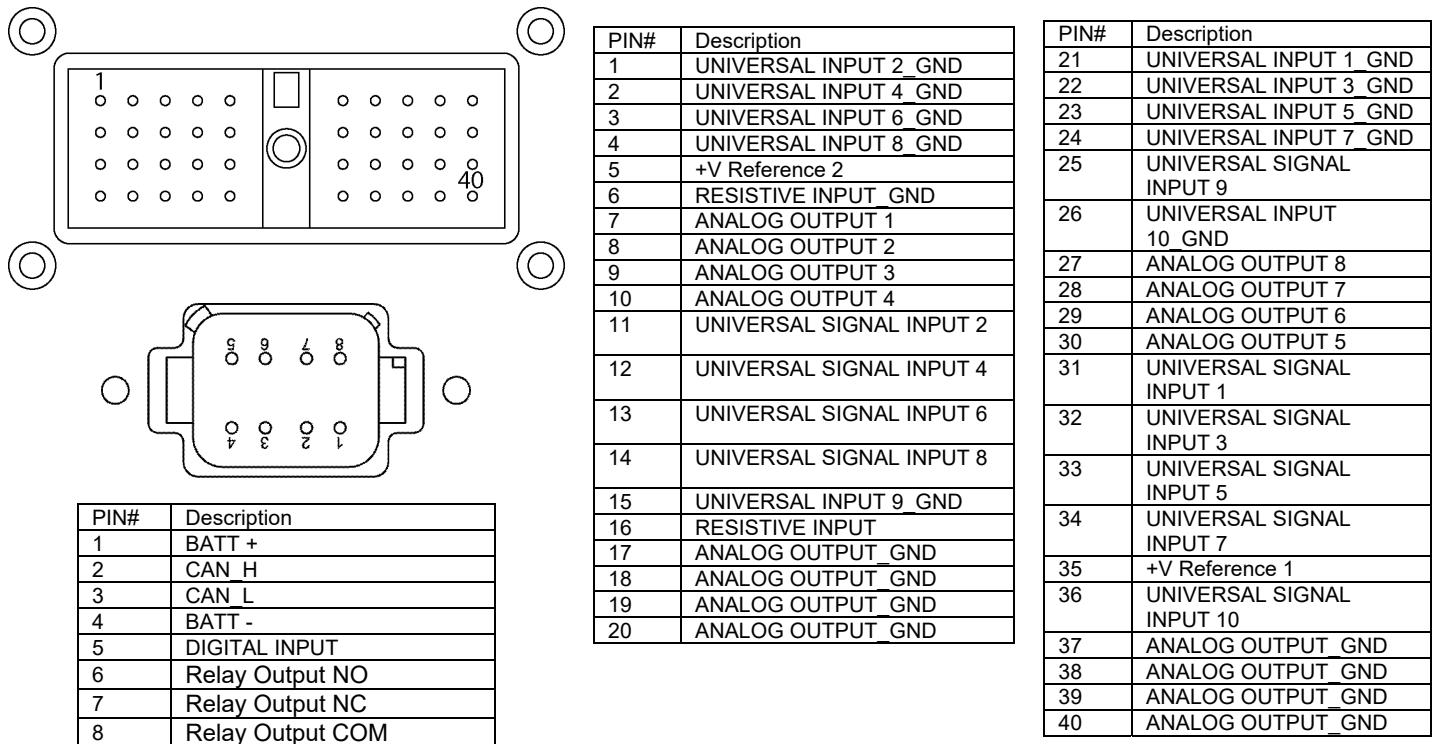

Table 26 – AX030211 Connector Pinouts

## 4. CANopen INTERFACE AND OBJECT DICTIONARY

The CANopen® object dictionary of the AX030211 Controller is based on CiA device profile DS-404 V4.1.0 (xxx device profile). The object dictionary includes Communication Objects beyond the minimum requirements in the profile, as well as several manufacturer-specific objects for extended functionality.

### 4.1. Node ID and Baud rate

By default, the AX030211 controller ships factory programmed with a

**Node ID = 127 (0x7F)**

and with

**Baud rate = 125 kbps.**

#### 4.1.1. LSS Protocol to Update

The only means by which the Node-ID and Baud rate can be changed is to use Layer Settling Services (LSS) and protocols as defined by CANopen® standard DS-305.

Follow the steps below to configure either variable using LSS protocol. If required, please refer to the standard for more detailed information about how to use the protocol

##### 4.1.1.1. Setting Node-ID

- Set the module state to LSS-configuration by **sending** the following message:

<i>Item</i>	<i>Value</i>
COB-ID	0x7E5
Length	2
Data 0	0x04 (cs=4 for switch state global)
Data 1	0x01 (switches to configuration state)

- Set the Node-ID by **sending** the following message:

<i>Item</i>	<i>Value</i>
COB-ID	0x7E5
Length	2
Data 0	0x11 (cs=17 for configure node-id)
Data 1	Node-ID (set new Node-ID as a hexadecimal number)

- The module will send the following response (any other response is a failure).

<i>Item</i>	<i>Value</i>
COB-ID	0x7E4
Length	3
Data 0	0x11 (cs=17 for configure node-id)
Data 1	0x00
Data 2	0x00

- Save the configuration by **sending** the following message:

<i>Item</i>	<i>Value</i>
COB-ID	0x7E5
Length	1
Data 0	0x17 (cs=23 for store configuration)

- The module will send the following response (any other response is a failure)

<i>Item</i>	<i>Value</i>
COB-ID	0x7E4
Length	3
Data 0	0x17 (cs=23 for store configuration)
Data 1	0x00
Data 2	0x00

- Set the module state to LSS-operation by **sending** the following message: (Note, the module will reset itself back to the pre-operational state)

<i>Item</i>	<i>Value</i>
COB-ID	0x7E5
Length	2
Data 0	0x04 (cs=4 for switch state global)
Data 1	0x00 (switches to waiting state)

#### 4.1.1.2. Setting Baud rate

- Set the module state to LSS-configuration by sending the following message:

<i>Item</i>	<i>Value</i>
COB-ID	0x7E5
Length	2
Data 0	0x04 (cs=4 for switch state global)
Data 1	0x01 (switches to configuration state)

- Set the baud rate by sending the following message:

<i>Item</i>	<i>Value</i>
COB-ID	0x7E5
Length	3
Data 0	0x13 (cs=19 for configure bit timing parameters)
Data 1	0x00 (switches to waiting state)
Data 2	Index (select baudrate index per Table 32)

<b>Index</b>	<b>Bit Rate</b>
<b>0</b>	1 Mbit/s
<b>1</b>	800 kbit/s
<b>2</b>	500 kbit/s
<b>3</b>	250 kbit/s
<b>4</b>	125 kbit/s (default)
<b>5</b>	reserved (100 kbit/s)
<b>6</b>	50 kbit/s
<b>7</b>	20 kbit/s
<b>8</b>	10 kbit/s

**Table 27 – LSS Baud rate Indices**

- The module will send the following response (any other response is a failure):

<b>Item</b>	<b>Value</b>
COB-ID	0x7E4
Length	3
Data 0	0x13 (cs=19 for configure bit timing parameters)
Data 1	0x00
Data 2	0x00

- Activate bit timing parameters by sending the following message:

<b>Item</b>	<b>Value</b>
COB-ID	0x7E5
Length	3
Data 0	0x15 (cs=19 for activate bit timing parameters)
Data 1	<delay_lsb>
Data 2	<delay_msb>

The delay individually defines the duration of the two periods of time to wait until the bit timing parameters switch is done (first period) and before transmitting any CAN message with the new bit timing parameters after performing the switch (second period). The time unit of switch delay is 1 ms.

- Save the configuration by sending the following message (on the NEW baud rate):

<b>Item</b>	<b>Value</b>
COB-ID	0x7E5
Length	1
Data 0	0x17 (cs=23 for store configuration)

- The module will send the following response (any other response is a failure):

<b>Item</b>	<b>Value</b>
COB-ID	0x7E4
Length	3
Data 0	0x17 (cs=23 for store configuration)
Data 1	0x00
Data 2	0x00

- Set the module state to LSS-operation by sending the following message: (Note, the module will reset itself back to the pre-operational state)

Item	Value
COB-ID	0x7E5
Length	2
Data 0	0x04 (cs=4 for switch state global)
Data 1	0x00 (switches to waiting state)

The following screen capture (left) shows the CAN data was sent (7E5h) and received (7E4h) by the tool when the baud rate was changed to 250 kbps using the LSS protocol. The other image (right) shows what was printed on an example debug RS-232 menu while the operation took place.

Between CAN Frame 98 and 99, the baud rate on the CAN Scope tool was changed from 125 to 250 kbps.

**Net0 | CAN USB331 | 250 - CANscope**

File Can Help

Add/Delete ID Area

from to Add > 0x000 <> 0x7FF Net: 0 - CAN\_USB331 Baud rate: 250

IDs decimal  29 >

Fram...	Absolute Time	RelTime	Id	Atr	L	d1	d2	d3	d4
95	11:42:45.248	6110	07E5		2	04	01		
96	11:42:54.468	9219	07E5		3	13	00	03	
97	11:42:54.468	0	07E4		3	13	00	00	
98	11:42:58.687	4218	07E5		3	15	88	13	
99	11:43:16.579	17891	07E5		1	17			
100	11:43:16.907	328	07E4		3	17	00	00	
101	11:43:23.017	6109	07E5		2	04	00		
102	11:43:23.017	0	0750		1	00			

Send ID:   29-Bit  RTR Len:  Data\$:

Fill: 102(10.2%) Bus: ok STARTED

File Edit Setup Control Window Help

```

===== Main Menu =====
Choose one of the following:
U: View Object Dictionary
D: Default Object Dictionary
T: Toggle RS-232 Stream On/Off
S: Show/Stop Diagnostics
L: Load New Software
M: Main Menu <this>

->Node Id = 80
->Baudrate= 125 [kbps]
CO: PRE-OPERATIONAL
Activating new baud = 250 [kbps]
CO: STOP
Restarting CAN in 5000 [ms]
CO: PRE-OPERATIONAL
Storing ID
Storing Factory Parameters

Storing Baud
Storing Factory Parameters

Storing Communication Parameters

->Node Id = 80
->Baudrate= 250 [kbps]
CO: PRE-OPERATIONAL

```

## 4.2. Communication Objects (DS-301)

<b>Index (hex)</b>	<b>Object</b>	<b>Object Type</b>	<b>Data Type</b>	<b>Access</b>	<b>PDO Mapping</b>
1000	Device Type	VAR	UNSIGNED32	RO	No
1001	Error Register	VAR	UNSIGNED8	RO	No
1002	Manufacturer Status Register	VAR	UNSIGNED32	RO	No
1003	Pre-Defined Error Field	ARRAY	UNSIGNED32	RO	No
1010	Store Parameters	ARRAY	UNSIGNED32	RW	No
1011	Restore Default Parameters	ARRAY	UNSIGNED32	RW	No
1016	Consumer Heartbeat Time	ARRAY	UNSIGNED32	RW	No
1017	Producer Heartbeat Time	VAR	UNSIGNED16	RW	No
1018	Identity Object	RECORD		RO	No
1020	Verify Configuration	ARRAY	UNSIGNED32	RO	No
1029	Error Behavior	ARRAY	UNSIGNED8	RW	No
1400	RPDO1 Communication Parameter	RECORD		RW	No
1401	RPDO2 Communication Parameter	RECORD		RW	No
1402	RPDO3 Communication Parameter	RECORD		RW	No
1403	RPDO4 Communication Parameter	RECORD		RW	No
1600	RPDO1 Mapping Parameter	RECORD		RO	No
1601	RPDO2 Mapping Parameter	RECORD		RO	No
1602	RPDO3 Mapping Parameter	RECORD		RO	No
1603	RPDO4 Mapping Parameter	RECORD		RO	No
1800	TPDO1 Communication Parameter	RECORD		RW	No
1801	TPDO2 Communication Parameter	RECORD		RW	No
1802	TPDO3 Communication Parameter	RECORD		RW	No
1803	TPDO4 Communication Parameter	RECORD		RW	No
1A00	TPDO1 Mapping Parameter	RECORD		RW	No
1A01	TPDO2 Mapping Parameter	RECORD		RW	No
1A02	TPDO3 Mapping Parameter	RECORD		RW	No
1A03	TPDO4 Mapping Parameter	RECORD		RW	No

### 4.2.1. 1000h Device Type

Index	Subindex	Data Type	Access	PDO Mapping	Value Range	Default Value	Description
1000	0	UINT32	RO	No	0x192	0x192	DS-402

### 4.2.2. 1001h Error Register

Index	Subindex	Data Type	Access	PDO Mapping	Value Range	Default Value	Description
1001	0	UINT8	RO	No	0, 1	0	Error register

### 4.2.3. 1002h Manufacturer Status Object

Index	Subindex	Data Type	Access	PDO Mapping	Value Range	Default Value	Description
1002	0	UINT32	RO	No	UINT32	0	Manufacturer debug information

### 4.2.4. 1003h Pre-Defined Error Field

Index	Subindex	Data Type	Access	PDO Mapping	Value Range	Default Value	Description
1003	0	UINT8	RW	No	15	15	Number of subindexes / reset error codes
	1	UINT32	RO		UINT32	0	EMCY error code #1
	2						EMCY error code #2
	3						EMCY error code #3
	4						EMCY error code #4
	5						EMCY error code #5
	6						EMCY error code #6
	7						EMCY error code #7
	8						EMCY error code #8
	9						EMCY error code #9
	10						EMCY error code #10
	11						EMCY error code #11
	12						EMCY error code #12
	13						EMCY error code #13
	14						EMCY error code #14
	15						EMCY error code #15

### 4.2.5. 1010h Store Parameters

Index	Subindex	Data Type	Access	PDO Mapping	Value Range	Default Value	Description
1010	0	UINT8	RO	No	4	4	Number of subindexes
	1	UINT32	RW		save	1	Write 0x65766173 ('e', 'v', 'a', 's') for storing ALL parameters
	2						Write 0x65766173 ('e', 'v', 'a', 's') for storing Communication parameters
	3						Write 0x65766173 ('e', 'v', 'a', 's') for storing Application parameters
	4						Write 0x65766173 ('e', 'v', 'a', 's') for storing Manufacturer parameters

#### 4.2.6. 1011h Restore Parameters

Index	Subindex	Data Type	Access	PDO Mapping	Value Range	Default Value	Description
1011	0	UINT8	RO	No	4	4	Number of subindexes
	1	UINT32	RW		load	1	Write 0x4616F6C ('d', 'a', 'o', 'l') for restoring ALL parameters
	2						Write 0x4616F6C ('d', 'a', 'o', 'l') for restoring Communication parameters
	3						Write 0x4616F6C ('d', 'a', 'o', 'l') for restoring Application parameters
	4						Write 0x4616F6C ('d', 'a', 'o', 'l') for restoring Manufacturer parameters

#### 4.2.7. 1016h Consumer Heartbeat Time

Index	Subindex	Data Type	Access	PDO Mapping	Value Range	Default Value	Description	
1016	0	UINT8	RO	No	4	4	Number of subindexes	
	1	UINT32	RW			UINT32	0	Consumer heartbeat time
	2							bits 31-24: reserved
	3							bits 23-16: Node ID
	4							bits 15-0: heartbeat time in milliseconds

#### 4.2.8. 1017h Producer Heartbeat Time

Index	Subindex	Data Type	Access	PDO Mapping	Value Range	Default Value	Description
1017	0	UINT16	RW	No	10-65000	0	Producer heartbeat time in milliseconds

#### 4.2.9. 1018h Identity Object

Index	Subindex	Data Type	Access	PDO Mapping	Value Range	Default Value	Description	
1018	0	UINT8	RO	No	4	4	Number of subindexes	
	1	UINT32				UINT32	0x55	Vendor ID (Axiomatic Technologies)
	2						0xAA100261	Product Code
	3							Revision Number
	4							Serial Number

#### 4.2.10. 1020h Verify Configuration

Index	Subindex	Data Type	Access	PDO Mapping	Value Range	Default Value	Description	
1020	0	UINT8	RO	No	4	4	Number of subindexes	
	1	UINT32				UINT32		Configuration date: DD-MM-YYYY
	2							Configuration time: HH-MM

#### 4.2.11. 1029h Error Behavior

Index	Subindex	Data Type	Access	PDO Mapping	Value Range	Default Value	Description
1029	0	UINT8	RO	No	6	4	Number of subindexes
	1		RW		0-2	1 (no change)	State transition on Comm. fault
	2						State transition on DI fault
	3						State transition on AI fault
	4						State transition on DO fault
	5						State transition on AO fault
6		State transition on other faults					

#### 4.2.12. 1400h RPDO 1 Communication Parameters

Index	Subindex	Data Type	Access	PDO Mapping	Value Range	Default Value	Description
1400	0	UINT8	RO	No	4	4	Number of subindexes
	1	UINT32	RW		UINT32	0x4000027F	COB-ID
	2	UINT8			UINT8	0xFF	Transmission type
	3	UINT16			UINT16	0	Inhibit time
	4	UINT8			UINT8	0	Compatibility entry
	5	UINT16			UINT16	0	Event timer

#### 4.2.13. 1401h RPDO 2 Communication Parameters

Index	Subindex	Data Type	Access	PDO Mapping	Value Range	Default Value	Description
1401	0	UINT8	RO	No	4	4	Number of subindexes
	1	UINT32	RW		UINT32	0x4000037F	COB-ID
	2	UINT8			UINT8	0xFF	Transmission type
	3	UINT16			UINT16	0	Inhibit time
	4	UINT8			UINT8	0	Compatibility entry
	5	UINT16			UINT16	0	Event timer

#### 4.2.14. 1402h RPDO 3 Communication Parameters

Index	Subindex	Data Type	Access	PDO Mapping	Value Range	Default Value	Description
1402	0	UINT8	RO	No	4	4	Number of subindexes
	1	UINT32	RW		UINT32	0xC000047F	COB-ID
	2	UINT8			UINT8	0xFF	Transmission type
	3	UINT16			UINT16	0	Inhibit time
	4	UINT8			UINT8	0	Compatibility entry
	5	UINT16			UINT16	0	Event timer

#### 4.2.15. 1403h RPDO 4 Communication Parameters

Index	Subindex	Data Type	Access	PDO Mapping	Value Range	Default Value	Description
1403	0	UINT8	RO	No	4	4	Number of subindexes
	1	UINT32	RW		UINT32	0xC000057F	COB-ID
	2	UINT8			UINT8	0xFF	Transmission type
	3	UINT16			UINT16	0	Inhibit time
	4	UINT8			UINT8	0	Compatibility entry
	5	UINT16			UINT16	0	Event timer

#### 4.2.16. 1600h RPDO 1 Mapping Parameters

Index	Subindex	Data Type	Access	PDO Mapping	Value Range	Default Value	Description
1600	0	UINT8	RW	No	0-4	2	Number of subindexes
	1	UINT32			UINT32	0x607E0008	Polarity
	2				0x60FF0020	Target velocity	
	3				0	Not used by default	
	4				0	Not used by default	

#### 4.2.17. 1601h RPDO 2 Mapping Parameters

Index	Subindex	Data Type	Access	PDO Mapping	Value Range	Default Value	Description
1601	0	UINT8	RW	No	0-4	4	Number of subindexes
	1	UINT32			UINT32	0x25000110	EC Extra Received PV Value 1
	2				0x25000210	EC Extra Received PV Value 2	
	3				0x25000310	EC Extra Received PV Value 3	
	4				0x25000410	EC Extra Received PV Value 4	

#### 4.2.18. 1602h RPDO 3 Mapping Parameters

Index	Subindex	Data Type	Access	PDO Mapping	Value Range	Default Value	Description
1602	0	UINT8	RW	No	0-4	0	Number of subindexes
	1	UINT32			UINT32	0	Not used by default
	2				0	Not used by default	
	3				0	Not used by default	
	4				0	Not used by default	

#### 4.2.19. 1603h RPDO 4 Mapping Parameters

Index	Subindex	Data Type	Access	PDO Mapping	Value Range	Default Value	Description
1603	0	UINT8	RW	No	0-4	0	Number of subindexes
	1	UINT32			UINT32	0	Not used by default
	2				0	Not used by default	
	3				0	Not used by default	
	4				0	Not used by default	

#### 4.2.20. 1800h TPDO 1 Communication Parameters

Index	Subindex	Data Type	Access	PDO Mapping	Value Range	Default Value	Description
1800	0	UINT8	RO	No	4	4	Number of subindexes
	1	UINT32	RW		UINT32	0x400001FF	COB-ID
	2	UINT8			UINT8	0xFE	Transmission type
	3	UINT16			UINT16	0	Inhibit time
	4	UINT8			UINT8	0	Compatibility entry
	5	UINT16			UINT16	0x64	Event timer

#### 4.2.21. 1801h TPDO 2 Communication Parameters

Index	Subindex	Data Type	Access	PDO Mapping	Value Range	Default Value	Description
1801	0	UINT8	RO	No	4	4	Number of subindexes
	1	UINT32	RW		UINT32	0x40002FF	COB-ID
	2	UINT8			UINT8	0xFE	Transmission type
	3	UINT16			UINT16	0	Inhibit time
	4	UINT8			UINT8	0	Compatibility entry
	5	UINT16			UINT16	0x64	Event timer

#### 4.2.22. 1802h TPDO 3 Communication Parameters

Index	Subindex	Data Type	Access	PDO Mapping	Value Range	Default Value	Description
1802	0	UINT8	RO	No	4	4	Number of subindexes
	1	UINT32	RW		UINT32	0x40003FF	COB-ID
	2	UINT8			UINT8	0xFE	Transmission type
	3	UINT16			UINT16	0	Inhibit time
	4	UINT8			UINT8	0	Compatibility entry
	5	UINT16			UINT16	0	Event timer

#### 4.2.23. 1803h TPDO 4 Communication Parameters

Index	Subindex	Data Type	Access	PDO Mapping	Value Range	Default Value	Description
1803	0	UINT8	RO	No	4	4	Number of subindexes
	1	UINT32	RW		UINT32	0xC0004FF	COB-ID
	2	UINT8			UINT8	0xFE	Transmission type
	3	UINT16			UINT16	0	Inhibit time
	4	UINT8			UINT8	0	Compatibility entry
	5	UINT16			UINT16	0	Event timer

#### 4.2.24. 1A00h TPDO 1 Mapping Parameters

Index	Subindex	Data Type	Access	PDO Mapping	Value Range	Default Value	Description
1A00	0	UINT8	RW	No	0-4	4	Number of subindexes
	1	UINT32			UINT32	0x71000110	Universal Input #1 FV
	2				0x71000210	Universal Input #2 FV	
	3				0x71000310	Universal Input #3 FV	
	4				0x71000410	Universal Input #4 FV	

#### 4.2.25. 1A01h TPDO 2 Mapping Parameters

Index	Subindex	Data Type	Access	PDO Mapping	Value Range	Default Value	Description
1A01	0	UINT8	RW	No	0-4	2	Number of subindexes
	1	UINT32			UINT32	0x60410010	PDS FSA Status Word
	2				0x606C0020	Velocity Actual Value	
	3				0	Not used by default	
	4				0	Not used by default	

#### 4.2.26. 1A02h TPDO 3 Mapping Parameters

Index	Subindex	Data Type	Access	PDO Mapping	Value Range	Default Value	Description
1A02	0	UINT8	RW	No	0-4	2	Number of subindexes
	1	UINT32			UINT32	0x50200020	Processor Temperature Field Value
	2				0x50300020	Power Supply Field Value	
	3				0	Not used by default	
	4				0	Not used by default	

#### 4.2.27. 1A03h TPDO 4 Mapping Parameters

Index	Subindex	Data Type	Access	PDO Mapping	Value Range	Default Value	Description
1A03	0	UINT8	RW	No	0-4	0	Number of subindexes
	1	UINT32			UINT32	0	Not used by default
	2				0	Not used by default	
	3				0	Not used by default	
	4				0	Not used by default	

### 4.3. Application Objects

<b>Index (hex)</b>	<b>Object</b>	<b>Object Type</b>	<b>Data Type</b>	<b>Access</b>	<b>PDO Mapping</b>
6000	DI Read State 8 Input Lines	VAR	UNSIGNED8	RO	Yes
6002	DI Polarity 8 Input Lines	VAR	UNSIGNED8	RW	No
6110	AI Sensor Type	ARRAY	UNSIGNED16	RW	No
6112	AI Operating Mode	ARRAY	UNSIGNED8	RW	No
6132	AI Decimal Digits PV	ARRAY	UNSIGNED8	RW	No
61A0	AI Filter Type	ARRAY	UNSIGNED8	RW	No
61A1	AI Filter Constant	ARRAY	UNSIGNED16	RW	No
6302	AO Decimal Digits PV	ARRAY	UNSIGNED8	RW	No
6310	AO Output Type	ARRAY	UNSIGNED8	RW	No
6332	AO Decimal Digits FV	ARRAY	UNSIGNED8	RW	No
6340	AO Fault Mode	ARRAY	UNSIGNED8	RW	No
6458	PID Physical Unit Timing	ARRAY	UNSIGNED32	RO	No
6459	PID Decimal Digits Timing	ARRAY	INTEGER8	RW	No
7100	AI Input Field Value	ARRAY	INTEGER16	RO	Yes
7120	AI Input Scaling 1 FV	ARRAY	INTEGER16	RW	No
7121	AI Input Scaling 1 PV	ARRAY	INTEGER16	RW	No
7122	AI Input Scaling 2 FV	ARRAY	INTEGER16	RW	No
7123	AI Input Scaling 2 PV	ARRAY	INTEGER16	RW	No
7130	AI Input Process Value	ARRAY	INTEGER16	RO	Yes
7148	AI Input Span Start	ARRAY	INTEGER16	RW	No
7149	AI Input Span End	ARRAY	INTEGER16	RW	No
7300	AO Output Field Value	ARRAY	INTEGER16	RO	Yes
7320	AO Output Scaling 1 PV	ARRAY	INTEGER16	RW	No
7321	AO Output Scaling 1 FV	ARRAY	INTEGER16	RW	No
7322	AO Output Scaling 2 PV	ARRAY	INTEGER16	RW	No
7323	AO Output Scaling 2 FV	ARRAY	INTEGER16	RW	No
7330	AO Output Process Value	ARRAY	INTEGER16	RO	Yes
7341	AO Output Fault FV	ARRAY	INTEGER16	RW	No
7450	PID Proportional Band	ARRAY	INTEGER16	RW	No
7452	PID Integral Action Time	ARRAY	INTEGER16	RW	No
7454	PID Derivative Action Time	ARRAY	INTEGER16	RW	No
7456	PID Cycle Time	ARRAY	INTEGER16	RW	No

### 4.3.1. 6000h DI Read State 8 Input Lines

Index	Subindex	Data Type	Access	PDO Mapping	Value Range	Default Value	Description
6000	0	UINT8	RO	No	2	2	Number of subindexes
	1				0-0xFF	0	Digital Input #1...#8 state bitmap, one bit per input
	2				0-0x0F	0	Digital Input #9...#12 state bitmap, one bit per input

### 4.3.2. 6002h DI Polarity 8 Input Lines

Index	Subindex	Data Type	Access	PDO Mapping	Value Range	Default Value	Description
6002	0	UINT8	RO	No	2	2	Number of subindexes
	1		RW		0-0xFF	0	Digital Input #1...#8 polarity bitmap, one bit per input
	2				0-0x0F	0	Digital Input #9...#12 polarity bitmap, one bit per input

### 4.3.3. 6110h AI Sensor Type

Index	Subindex	Data Type	Access	PDO Mapping	Value Range	Default Value	Description
6110	0	UINT8	RO	No	12	12	Number of subindexes
	1...12	UINT16	RW		40,50, 60,100, 10000, 10002	40	Input #1 ... #12 sensor type

### 4.3.4. 6112h AI Operating Mode

Index	Subindex	Data Type	Access	PDO Mapping	Value Range	Default Value	Description
6112	0	UINT8	RO	No	12	12	Number of subindexes
	1...12		RW		0-2, sensor type dependent.	1	Input #1 ... #12 operating mode

### 4.3.5. 6132h AI Decimal Digits PV

Index	Subindex	Data Type	Access	PDO Mapping	Value Range	Default Value	Description
6132	0	UINT8	RO	No	12	12	Number of subindexes
	1...12		RW		0-3	3	Input #1 ... #12 process value decimal digits

### 4.3.6. 61A0h AI Filter Type

Index	Subindex	Data Type	Access	PDO Mapping	Value Range	Default Value	Description
61A0	0	UINT8	RO	No	12	12	Number of subindexes
	1...12		RW		0-2	0	Input #1 ... #12 software filter type

### 4.3.7. 61A1h AI Filter Constant

Index	Subindex	Data Type	Access	PDO Mapping	Value Range	Default Value	Description
61A1	0	UINT8	RO	No	12	12	Number of subindexes
	1...12	UINT16	RW		1-1000	1	Input #1 ... #12 software filter constant

### 4.3.8. 6302h AO Decimal Digits PV

Index	Subindex	Data Type	Access	PDO Mapping	Value Range	Default Value	Description
6302	0	UINT8	RO	No	9	9	Number of subindexes
	1...9		RW		0-3	0	Output #1 ... #9 process value decimal digits

### 4.3.9. 6310h AO Output Type

Index	Subindex	Data Type	Access	PDO Mapping	Value Range	Default Value	Description
6310	0	UINT8	RO	No	9	9	Number of subindexes
	1...9	UINT16	RW		0, 10, 20	10	Output #1 ... #9 type, see Table 11 for details

### 4.3.10. 6332h AO Decimal Digits FV

Index	Subindex	Data Type	Access	PDO Mapping	Value Range	Default Value	Description
6332	0	UINT8	RO	No	9	9	Number of subindexes
	1...9		RW		0-3	0	Output #1 ... #9 field value decimal digits

### 4.3.1. 6340h AO Fault Mode

Index	Subindex	Data Type	Access	PDO Mapping	Value Range	Default Value	Description
6340	0	UINT8	RO	No	9	9	Number of subindexes
	1...9		RW		0-1	0	0 – no change on fault 1 – apply fault FV on fault (object 7341h)

### 4.3.2. 6458h PID Physical Unit Timing

Index	Subindex	Data Type	Access	PDO Mapping	Value Range	Default Value	Description
6458	0	UINT8	RO	No	2	2	Number of subindexes
	1...2	UINT32			12288	12288	Additional PID controller physical unit timing

### 4.3.3. 6459h PID Decimal Digits Timing

Index	Subindex	Data Type	Access	PDO Mapping	Value Range	Default Value	Description
6459	0	UINT8	RW	No	2	2	Number of subindexes
	1...2				0-4	3	Additional PID controller decimal digits timing

### 4.3.4. 7100h AI Input Field Value

Index	Subindex	Data Type	Access	PDO Mapping	Value Range	Default Value	Description
7100	0	UINT8	RO	No	12	12	Number of subindexes
	1...12	INT16	RW		INT16	0	Input #1 ... #12 field value

### 4.3.5. 7120h AI Input Scaling 1 FV

Index	Subindex	Data Type	Access	PDO Mapping	Value Range	Default Value	Description
7120	0	UINT8	RO	No	12	12	Number of subindexes
	1...12	INT16	RW		INT16	0	Input #1 ... #12 field value scaler 1

### 4.3.6. 7121h AI Input Scaling 1 PV

Index	Subindex	Data Type	Access	PDO Mapping	Value Range	Default Value	Description
7121	0	UINT8	RO	No	12	12	Number of subindexes
	1...12	INT16	RW		INT16	0	Input #1 ... #12 process value scaler 1

### 4.3.7. 7122h AI Input Scaling 2 FV

Index	Subindex	Data Type	Access	PDO Mapping	Value Range	Default Value	Description
7122	0	UINT8	RO	No	12	12	Number of subindexes
	1...12	INT16	RW		INT16	0	Input #1 ... #12 field value scaler 2

### 4.3.8. 7123h AI Input Scaling 2 PV

Index	Subindex	Data Type	Access	PDO Mapping	Value Range	Default Value	Description
7123	0	UINT8	RO	No	12	12	Number of subindexes
	1...12	INT16	RW		INT16	0	Input #1 ... #12 process value scaler 2

### 4.3.9. 7130h AI Input Process Value

Index	Subindex	Data Type	Access	PDO Mapping	Value Range	Default Value	Description
7130	0	UINT8	RO	No	6	6	Number of subindexes
	1...12	INT16	RW		Yes	INT16	0

#### 4.3.10. 7148h AI Input Span Start

Index	Subindex	Data Type	Access	PDO Mapping	Value Range	Default Value	Description
7148	0	UINT8	RO	No	12	12	Number of subindexes
	1...12	INT16	RW		Input type dependent	200	Input #1 ... #12 span start

#### 4.3.11. 7149h AI Input Span End

Index	Subindex	Data Type	Access	PDO Mapping	Value Range	Default Value	Description
7149	0	UINT8	RO	No	12	12	Number of subindexes
	1...12	INT16	RW		Input type dependent	4800	Input #1 ... #12 span end

#### 4.3.12. 7300h AO Output Process Value

Index	Subindex	Data Type	Access	PDO Mapping	Value Range	Default Value	Description
7300	0	UINT8	RO	No	9	9	Number of subindexes
	1...9	INT16	RW		INT16	0	Output #1 ... #9 process value

#### 4.3.13. 7320h AO Output Scaling 1 PV

Index	Subindex	Data Type	Access	PDO Mapping	Value Range	Default Value	Description
7320	0	UINT8	RO	No	9	9	Number of subindexes
	1...9	INT16	RW		INT16	0	Output #1 ... #9 process value scaler 1

#### 4.3.14. 7321h AO Output Scaling 2 FV

Index	Subindex	Data Type	Access	PDO Mapping	Value Range	Default Value	Description
7321	0	UINT8	RO	No	9	9	Number of subindexes
	1...9	INT16	RW		INT16	0	Output #1 ... #9 field value scaler 2

#### 4.3.15. 7322h AO Output Scaling 1 PV

Index	Subindex	Data Type	Access	PDO Mapping	Value Range	Default Value	Description
7322	0	UINT8	RO	No	9	9	Number of subindexes
	1...9	INT16	RW		INT16	0	Output #1 ... #9 process value scaler 1

#### 4.3.16. 7323h AO Output Scaling 2 FV

Index	Subindex	Data Type	Access	PDO Mapping	Value Range	Default Value	Description
7323	0	UINT8	RO	No	9	9	Number of subindexes
	1...9	INT16	RW		INT16	0	Output #1 ... #9 field value scaler 2

#### 4.3.17. 7330h AO Output Field Value

Index	Subindex	Data Type	Access	PDO Mapping	Value Range	Default Value	Description
7330	0	UINT8	RO	No	9	9	Number of subindexes
	1...9	INT16	RW	Yes	INT16	0	Output #1 ... #9 field value

#### 4.3.18. 7341h AO Output Fault FV

Index	Subindex	Data Type	Access	PDO Mapping	Value Range	Default Value	Description
7341	0	UINT8	RO	No	9	9	Number of subindexes
	1...9	INT16	RW		INT16	0	Output #1 ... #9 fault field value

#### 4.3.19. 7450h PID Proportional Band

Index	Subindex	Data Type	Access	PDO Mapping	Value Range	Default Value	Description
7450	0	UINT8	RO	No	2	2	Number of subindexes
	1...2	INT16	RW		0-100	5	Additional PID #1 ... #2 controller P gain

#### 4.3.20. 7452h PID Integral Action Time

Index	Subindex	Data Type	Access	PDO Mapping	Value Range	Default Value	Description
7452	0	UINT8	RO	No	2	2	Number of subindexes
	1...2	INT16	RW		0-1000	5	Additional PID #1 ... #2 controller integral action time

#### 4.3.21. 7454h PID Derivative Action Time

Index	Subindex	Data Type	Access	PDO Mapping	Value Range	Default Value	Description
7454	0	UINT8	RO	No	2	2	Number of subindexes
	1...2	INT16	RW		0-1000	1	Additional PID #1 ... #2 controller derivative action time

#### 4.3.22. 7456h PID Cycle Time

Index	Subindex	Data Type	Access	PDO Mapping	Value Range	Default Value	Description
7456	0	UINT8	RO	No	2	2	Number of subindexes
	1...2	INT16	RW		0-1000	1	Additional PID #1 ... #2 controller cycle time

#### 4.4. Manufacturer Objects

<b>Index (hex)</b>	<b>Object</b>	<b>Object Type</b>	<b>Data Type</b>	<b>Access</b>	<b>PDO Mapping</b>
2020	DI Pull Up Down Mode 1 Input Line	ARRAY	UNSIGNED8	RW	No
2100	AI Input Range	ARRAY	UNSIGNED8	RW	No
2101	AI Pulses Per Revolution	ARRAY	UNSIGNED8	RW	No
2102	AI Decimal Digits FV	ARRAY	UNSIGNED8	RW	No
2103	AI Debounce Filter	ARRAY	UNSIGNED8	RW	No
2110	AI Error Detect Enable	ARRAY	BOOLEAN	RW	No
2111	AI Error Clear Hysteresis	ARRAY	INTEGER16	RW	No
2112	AI Error Reaction Delay	ARRAY	UNSIGNED16	RW	No
2302	AO Output Range	ARRAY	UNSIGNED8	RW	No
2330	AO Ramp Up	ARRAY	UNSIGNED16	RW	No
2331	AO Ramp Down	ARRAY	UNSIGNED16	RW	No
2340	AO Control Input Source	ARRAY	UNSIGNED8	RW	No
2341	AO Control Input Number	ARRAY	UNSIGNED8	RW	No
2350	AO Enable Input Source	ARRAY	UNSIGNED8	RW	No
2351	AO Enable Input Number	ARRAY	UNSIGNED8	RW	No
2352	AO Enable Input Response	ARRAY	UNSIGNED8	RW	No
2353	AO Disable Drive FV	ARRAY	INTEGER16	RW	Yes
2360	AO Override Input Source	ARRAY	UNSIGNED8	RW	No
2361	AO Override Input Number	ARRAY	UNSIGNED8	RW	No
2362	AO Override Response	ARRAY	UNSIGNED8	RW	No
2450	PID Tolerance	VAR	INTEGER16	RW	No
2451	PID Integral Gain	VAR	INTEGER16	RW	No
2452	PID Derivative Gain	VAR	INTEGER16	RW	No
2453	PID Target Source	VAR	UNSIGNED8	RW	No
2454	PID Target Number	VAR	UNSIGNED8	RW	No
2455	PID Feedback Source	VAR	UNSIGNED8	RW	No
2456	PID Feedback Number	VAR	UNSIGNED8	RW	No
2457	PID Control Response	VAR	UNSIGNED8	RW	No
2460	PID Output Field Value	VAR	INTEGER16	RO	Yes
2500	EC Extra Received Process Value	ARRAY	INTEGER16	RW	Yes
2502	EC Decimal Digits PV	ARRAY	UNSIGNED8	RW	No
2520	EC Scaling 1 PV	ARRAY	INTEGER16	RW	No
2522	EC Scaling 2 PV	ARRAY	INTEGER16	RW	No
30z0	LT0z Input X-Axis Source	VAR	UNSIGNED8	RW	No
30z1	LT0z Input X-Axis Number	VAR	UNSIGNED8	RW	No
30z2	LT0z Auto Repeat	VAR	UNSIGNED8	RW	No
30z3	LT0z X-Axis Decimal Digits PV	VAR	UNSIGNED8	RW	No
30z4	LT0z Y-Axis Decimal Digits PV	VAR	UNSIGNED8	RW	No
30z5	LT0z Point Response	ARRAY	UNSIGNED8	RW	No
30z6	LT0z Point X-Axis PV	ARRAY	INTEGER32	RW	No
30z7	LT0z Point Y-Axis PV	ARRAY	INTEGER16	RW	No
30z8	LT0z Output Y-Axis PV	VAR	INTEGER16	RO	Yes
3300	Logic Block Enable	ARRAY	BOOLEAN	RW	No
3310	Logic Block Selected Table	ARRAY	UNSIGNED8	RO	Yes
3320	Logic Output Process Value	ARRAY	INTEGER16	RO	Yes

3x01	LB(x-3) Lookup Table Number	ARRAY	UNSIGNED8	RW	No
3x02	LB(x-3) Function Logical Operator	ARRAY	UNSIGNED8	RW	No
3x11	LB(x-3) Function A Condition 1	RECORD	UNSIGNED8	RW	No
3x12	LB(x-3) Function A Condition 2	RECORD	UNSIGNED8	RW	No
3x13	LB(x-3) Function A Condition 3	RECORD	UNSIGNED8	RW	No
3x21	LB(x-3) Function B Condition 1	RECORD	UNSIGNED8	RW	No
3x22	LB(x-3) Function B Condition 2	RECORD	UNSIGNED8	RW	No
3x23	LB(x-3) Function B Condition 3	RECORD	UNSIGNED8	RW	No
3x31	LB(x-3) Function C Condition 1	RECORD	UNSIGNED8	RW	No
3x32	LB(x-3) Function C Condition 2	RECORD	UNSIGNED8	RW	No
3x33	LB(x-3) Function C Condition 3	RECORD	UNSIGNED8	RW	No
4000	Math Block Enable	ARRAY	BOOLEAN	RW	No
4021	Math Output Scaling 1 PV	ARRAY	INTEGER16	RW	No
4023	Math Output Scaling 2 PV	ARRAY	INTEGER16	RW	No
4030	Math Output Process Value	ARRAY	INTEGER16	RO	Yes
4032	Math Output Decimal Digits PV	ARRAY	UNSIGNED8	RW	No
4y00	Math Y Input Source	ARRAY	UNSIGNED8	RW	No
4y01	Math Y Input Number	ARRAY	UNSIGNED8	RW	No
4y03	Math Y Input Decimal Digits FV	ARRAY	UNSIGNED8	RW	No
4y20	Math Y Input Scaling 1 FV	ARRAY	INTEGER16	RW	No
4y22	Math Y Input Scaling 2 FV	ARRAY	INTEGER16	RW	No
4y40	Math Y Input Gain	ARRAY	INTEGER8	RW	No
4y50	Math Y Operator	ARRAY	UNSIGNED8	RW	No
5010	Constant Field Value	ARRAY	FLOAT32	RW	No
5020	Power Supply FV	VAR	FLOAT32	RO	Yes
5030	CPU Temperature FV	VAR	FLOAT32	RO	Yes
5040	Fault Detection Field Value	ARRAY	UNSIGNED16	RO	Yes
5041	Fault Detection Set Threshold	ARRAY	UNSIGNED16	RW	No
5042	Fault Detection Clear Threshold	ARRAY	UNSIGNED16	RW	No
5050	Fault Detection Enable Err Check 3	ARRAY	UNSIGNED8	RW	No
5051	Fault Detection Error Response Delay	ARRAY	UNSIGNED16	RW	No
5120	VREF Control Source	ARRAY	UNSIGNED8	RW	No
5121	VREF Control Number	ARRAY	UNSIGNED8	RW	No
5555	Start in Operational Mode	VAR	BOOLEAN	RW	No
5556	Start in Operational NMT Delay	VAR	UNSIGNED16	RW	No

#### 4.4.1. 2020h DI Pull Up Down Mode 1 Input Line

Index	Subindex	Data Type	Access	PDO Mapping	Value Range	Default Value	Description
2020	0	UINT8	RO	No	12	12	Number of subindexes
	1		RW		0–no pull 1 – PU 2 – PD	0	Input #1...#12 pull up / down selection

#### 4.4.2. 2100h AI Input Range

Index	Subindex	Data Type	Access	PDO Mapping	Value Range	Default Value	Description
2100	0	UINT8	RO	No	12	12	Number of subindexes
	1...12		RW		Input type dependent	0	Input #1...#12 range selection

#### 4.4.3. 2101h AI Number of Pulses per Revolution

Index	Subindex	Data Type	Access	PDO Mapping	Value Range	Default Value	Description
2101	0	UINT8	RO	No	12	12	Number of subindexes
	1...12	UINT16	RW		0-1000	0	Input #1...#12 PPR. When 0, no rpm conversion done

#### 4.4.4. 2102h AI Decimal Digits FV

Index	Subindex	Data Type	Access	PDO Mapping	Value Range	Default Value	Description
2102	0	UINT8	RO	No	12	12	Number of subindexes
	1...12		RW		0-4	3	Input #1...#12 decimal digits FV

#### 4.4.5. 2103h AI Debounce Filter

Index	Subindex	Data Type	Access	PDO Mapping	Value Range	Default Value	Description
2103	0	UINT8	RO	No	12	12	Number of subindexes
	1...12		RW		0-4	3	Input #1...#12 debounce filter selection

#### 4.4.6. 2110h AI Error Detect Enable

Index	Subindex	Data Type	Access	PDO Mapping	Value Range	Default Value	Description
2110	0	UINT8	RO	No	12	12	Number of subindexes
	1...12		RW		0, 1	0	Input #1...#12 error detect enable

#### 4.4.7. 2111h AI Error Clear Hysteresis

Index	Subindex	Data Type	Access	PDO Mapping	Value Range	Default Value	Description
2111	0	UINT8	RO	No	12	12	Number of subindexes
	1...12	INT16	RW		0-32767	100	Input #1...#12 error clear hysteresis

#### 4.4.8. 2112h AI Error Reaction Delay

Index	Subindex	Data Type	Access	PDO Mapping	Value Range	Default Value	Description
2112	0	UINT8	RO	No	12	12	Number of subindexes
	1...12	UINT16	RW		0-60000	1000	Input #1...#12 error reaction delay in ms

#### 4.4.9. 2302h AO Output Range

Index	Subindex	Data Type	Access	PDO Mapping	Value Range	Default Value	Description
2302	0	UINT8	RO	No	9	9	Number of subindexes
	1...9		RW		0-4	3	Output #1...#9 range

#### 4.4.10. 2330h AO Ramp Up

Index	Subindex	Data Type	Access	PDO Mapping	Value Range	Default Value	Description
2330	0	UINT8	RO	No	9	9	Number of subindexes
	1...9	UINT16	RW		0-60000	1000	Output #1...#9 ramp up time in ms

#### 4.4.11. 2331h AO Ramp Down

Index	Subindex	Data Type	Access	PDO Mapping	Value Range	Default Value	Description
2331	0	UINT8	RO	No	9	9	Number of subindexes
	1...9	UINT16	RW		0-60000	1000	Output #1...#9 ramp down time in ms

#### 4.4.12. 2340h AO Control Input Source

Index	Subindex	Data Type	Access	PDO Mapping	Value Range	Default Value	Description
2340	0	UINT8	RO	No	9	9	Number of subindexes
	1...9		RW		0-15	0	Output #1...#9 control source, see Table 23 for details.

#### 4.4.13. 2341h AO Control Input Number

Index	Subindex	Data Type	Access	PDO Mapping	Value Range	Default Value	Description
2341	0	UINT8	RO	No	9	9	Number of subindexes
	1...9		RW		depends on Control Source	1	Output #1...#9 control number, see Table 23 for details.

#### 4.4.14. 2350h AO Enable Input Source

Index	Subindex	Data Type	Access	PDO Mapping	Value Range	Default Value	Description
2350	0	UINT8	RO	No	9	9	Number of subindexes
	1...9		RW		0-15	0	Output #1...#9 enable source, see Table 23 for details.

#### 4.4.15. 2351h AO Enable Input Number

Index	Subindex	Data Type	Access	PDO Mapping	Value Range	Default Value	Description
2351	0	UINT8	RO	No	9	9	Number of subindexes
	1...9		RW		depends on Enable Source	1	Output #1...#9 enable number, see Table 23 for details.

#### 4.4.16. 2352h AO Enable Response

Index	Subindex	Data Type	Access	PDO Mapping	Value Range	Default Value	Description
2352	0	UINT8	RO	No	9	9	Number of subindexes
	1...9		RW		0-1	0	0 – Enable when 'on' 1 – Enable when 'off'

#### 4.4.17. 2353h AO Disable Drive FV

Index	Subindex	Data Type	Access	PDO Mapping	Value Range	Default Value	Description
2353	0	INT16	RO	Yes	9	9	Number of subindexes
	1...9		RW		INT16	0	FV value when Enable Source is configured and output is not enabled or Controller output driving disabled because of the mode of operation.

#### 4.4.18. 2360h AO Override Input Source

Index	Subindex	Data Type	Access	PDO Mapping	Value Range	Default Value	Description
2360	0	UINT8	RO	No	9	9	Number of subindexes
	1...9		RW		0-15	0	Output #1...#9 override source, see Table 23 for details.

#### 4.4.19. 2361h AO Override Input Number

Index	Subindex	Data Type	Access	PDO Mapping	Value Range	Default Value	Description
2361	0	UINT8	RO	No	9	9	Number of subindexes
	1...9		RW		depends on Enable Source	1	Output #1...#9 override number, see Table 23 for details.

#### 4.4.20. 2362h AO Override Response

Index	Subindex	Data Type	Access	PDO Mapping	Value Range	Default Value	Description
2362	0	UINT8	RO	No	9	9	Number of subindexes
	1...9		RW		0-1	0	0 – Override when 'on' 1 – Override when 'off'

#### 4.4.21. 2450h PID Tolerance

Index	Subindex	Data Type	Access	PDO Mapping	Value Range	Default Value	Description
2450	0	UINT8	RO	No	2	2	Number of subindexes
	1...2	INT16	RW		0-100	10	Additional PID controller tolerance

#### 4.4.22. 2451h PID Integral Gain

Index	Subindex	Data Type	Access	PDO Mapping	Value Range	Default Value	Description
2451	0	UINT8	RO	No	2	2	Number of subindexes
	1...2	INT16	RW		0-100	10	Additional PID controller integral gain

#### 4.4.23. 2452h PID Derivative Gain

Index	Subindex	Data Type	Access	PDO Mapping	Value Range	Default Value	Description
2452	0	UINT8	RO	No	2	2	Number of subindexes
	1...2	INT16	RW		0-100	10	Additional PID controller derivative gain

#### 4.4.24. 2453h PID Target Source

Index	Subindex	Data Type	Access	PDO Mapping	Value Range	Default Value	Description
2453	0	UINT8	RO	No	2	2	Number of subindexes
	1...2		RW		0-10	0	By default disabled. See Table 23

#### 4.4.25. 2454h PID Target Number

Index	Subindex	Data Type	Access	PDO Mapping	Value Range	Default Value	Description
2454	0	UINT8	RO	No	2	2	Number of subindexes
	1...2		RW		0-16	1	By default disabled. See Table 23

#### 4.4.26. 2455h PID Feedback Source

Index	Subindex	Data Type	Access	PDO Mapping	Value Range	Default Value	Description
2455	0	UINT8	RO	No	2	2	Number of subindexes
	1...2		RW		0-10	0	By default disabled. See Table 23

#### 4.4.27. 2456h PID Feedback Number

Index	Subindex	Data Type	Access	PDO Mapping	Value Range	Default Value	Description
2456	0	UINT8	RO	No	2	2	Number of subindexes
	1...2		RW		0-16	1	By default disabled. See Table 23

#### 4.4.28. 2457h PID Control Response

Index	Subindex	Data Type	Access	PDO Mapping	Value Range	Default Value	Description
4257	0	UINT8	RO	No	2	2	Number of subindexes
	1...2		RW		0-3	0	Additional PID controller response selection

#### 4.4.29. 2460h PID Output FV

Index	Subindex	Data Type	Access	PDO Mapping	Value Range	Default Value	Description
4260	0	UINT8	RO	No	2	2	Number of subindexes
	1...2	INT16			0-1000	0	Additional PID controller output FV

#### 4.4.30. 2500h EC Extra Received PV

Index	Subindex	Data Type	Access	PDO Mapping	Value Range	Default Value	Description
2500	0	UINT8	RO	Yes	9	9	Number of subindexes
	1...9	INT16	RW		INT16	0	Extra received PV #1 ... #9

#### 4.4.31. 2502h EC Decimal Digits PV

Index	Subindex	Data Type	Access	PDO Mapping	Value Range	Default Value	Description
2502	0	UINT8	RO	No	9	9	Number of subindexes
	1...9		RW		0-3	1	Extra received PV #1 ... #9 decimal digits

#### 4.4.32. 2520h EC Scaling 1 PV

Index	Subindex	Data Type	Access	PDO Mapping	Value Range	Default Value	Description
2520	0	UINT8	RO	No	9	9	Number of subindexes
	1...9	INT16	RW		INT16	0	EC #1 ... #9 process value scaler 1

#### 4.4.33. 2522h EC Scaling 2 PV

Index	Subindex	Data Type	Access	PDO Mapping	Value Range	Default Value	Description
2522	0	UINT8	RO	No	9	9	Number of subindexes
	1...9	INT16	RW		INT16	0	EC #1 ... #9 process value scaler 2

#### 4.4.34. 30z0h LT0z Input X Axis Source

Index	Subindex	Data Type	Access	PDO Mapping	Value Range	Default Value	Description
30z0	0	UINT8	RO	No	1	1	Number of subindexes
	1		RW		0-15	0	LUT #z x axis data source, see Table 23 for details.

#### 4.4.35. 30z1h LT0z Input X Axis Number

Index	Subindex	Data Type	Access	PDO Mapping	Value Range	Default Value	Description
30z1	0	UINT8	RO	No	1	1	Number of subindexes
	1		RW		depends on Data Source	1	LUT #z x axis data number, see Table 23 for details.

#### 4.4.36. 30z2h LT0z Auto Repeat

Index	Subindex	Data Type	Access	PDO Mapping	Value Range	Default Value	Description
30z2	0	UINT8	RO	No	1	1	Number of subindexes
	1		RW		0, 1	0	LUT #z auto repeat

#### 4.4.37. 30z3h LT0z X Axis Decimal Digits

Index	Subindex	Data Type	Access	PDO Mapping	Value Range	Default Value	Description
30z3	0	UINT8	RO	No	1	1	Number of subindexes
	1		RW		0-3	1	LUT #z x-axis decimal digits

#### 4.4.38. 30z4h LT0z Y Axis Decimal Digits

Index	Subindex	Data Type	Access	PDO Mapping	Value Range	Default Value	Description
30z4	0	UINT8	RO	No	1	1	Number of subindexes
	1		RW		0-3	1	LUT #z y-axis decimal digits

#### 4.4.39. 30z5h LT0z Point Response

Index	Subindex	Data Type	Access	PDO Mapping	Value Range	Default Value	Description
30z5	0	UINT8	RO	No	12	12	Number of subindexes
	1...12		RW		0-2	1	LUT #z point response 0 – Ignore 1 – Ramp to 2 – Jump to

#### 4.4.40. 30z6h LT0z X Axis Process Value

Index	Subindex	Data Type	Access	PDO Mapping	Value Range	Default Value	Description
30z6	0	UINT8	RO	No	10	10	Number of subindexes
	1...10	INT32	RW		INT32	0	LUT #z x-axis PV #1 ... #10

#### 4.4.41. 30z7h LT0z Y Axis Process Value

Index	Subindex	Data Type	Access	PDO Mapping	Value Range	Default Value	Description
30z7	0	UINT8	RO	No	10	10	Number of subindexes
	1...10	INT32	RW		INT32	0	LUT #z y-axis PV #1 ... #10

#### 4.4.42. 30z8h LT0z Output Y Axis Process Value

Index	Subindex	Data Type	Access	PDO Mapping	Value Range	Default Value	Description
30z8	0	UINT8	RO	No	1	1	Number of subindexes
	1	INT16		Yes	INT16	0	LUT #z y-axis output process value

#### 4.4.43. 3300h Logic Block Enable

Index	Subindex	Data Type	Access	PDO Mapping	Value Range	Default Value	Description
3300	0	UINT8	RO	No	1	1	Number of subindexes
	1...2		RW		0, 1	0	Logic block #1 ... #2 enable

#### 4.4.44. 3310h Logic Block Selected Table

Index	Subindex	Data Type	Access	PDO Mapping	Value Range	Default Value	Description
3310	0	UINT8	RO	No	1	1	Number of subindexes
	1...2			Yes	0...2	0	Logic block #1 ... #2 selected table

#### 4.4.45. 3320h Logic Block Output Process Value

Index	Subindex	Data Type	Access	PDO Mapping	Value Range	Default Value	Description
3320	0	UINT8	RO	No	1	1	Number of subindexes
	1...2	INT16		Yes	INT16	0	Logic block #1 ... #2 output process value

#### 4.4.46. 3x01h Logic Block (x-3) Lookup Table Number

Index	Subindex	Data Type	Access	PDO Mapping	Value Range	Default Value	Description
3x01*	0	UINT8	RO	No	1	1	Number of subindexes
	1...3		RW		0...4	0	Logic block #(x-3) lookup table number #1 ... #3

\* objects 3401h, 3501h

#### 4.4.47. 3x02h Logic Block (x-3) Function Logical Operator

Index	Subindex	Data Type	Access	PDO Mapping	Value Range	Default Value	Description
3x02*	0	UINT8	RO	No	1	1	Number of subindexes
	1...3		RW		0...4	0	Logic block #(x-3) function logical operator, see Table 19 for details

\* objects 3402h, 3502h

#### 4.4.48. 3x11h Logic Block (x-3) Function A Condition 1

Index	Subindex	Data Type	Access	PDO Mapping	Value Range	Default Value	Description	
3x11*	0	UINT8	RO	No	5	5	Number of subindexes	
	1		RW		Table	23	0	LB(x-3) Function A Condition 1 Arg 1 Source
	2					1	LB(x-3) Function A Condition 1 Arg 1 Number	
	3					0	LB(x-3) Function A Condition 1 Arg 2 Source	
	4					1	LB(x-3) Function A Condition 1 Arg 2 Number	
	5					0	LB(x-3) Function A Condition 1 Operator	

\* objects 3411h, 3511h

#### 4.4.49. 3x12h Logic Block (x-3) Function A Condition 2

Index	Subindex	Data Type	Access	PDO Mapping	Value Range	Default Value	Description	
3x12*	0	UINT8	RO	No	5	5	Number of subindexes	
	1		RW		Table	0	0	LB(x-3) Function A Condition 2 Arg 1 Source
	2					1	1	LB(x-3) Function A Condition 2 Arg 1 Number
	3				23	0	0	LB(x-3) Function A Condition 2 Arg 2 Source
	4					1	1	LB(x-3) Function A Condition 2 Arg 2 Number
	5					17	0	0

\* objects 3412h, 3512h

#### 4.4.50. 3x13h Logic Block (x-3) Function A Condition 3

Index	Subindex	Data Type	Access	PDO Mapping	Value Range	Default Value	Description	
3x13*	0	UINT8	RO	No	5	5	Number of subindexes	
	1		RW		Table	0	0	LB(x-3) Function A Condition 3 Arg 1 Source
	2					1	1	LB(x-3) Function A Condition 3 Arg 1 Number
	3				23	0	0	LB(x-3) Function A Condition 3 Arg 2 Source
	4					1	1	LB(x-3) Function A Condition 3 Arg 2 Number
	5					17	0	0

\* objects 3413h, 3513h

#### 4.4.51. 3x21h Logic Block (x-3) Function B Condition 1

Index	Subindex	Data Type	Access	PDO Mapping	Value Range	Default Value	Description	
3x21*	0	UINT8	RO	No	5	5	Number of subindexes	
	1		RW		Table	0	0	LB(x-3) Function B Condition 1 Arg 1 Source
	2					1	1	LB(x-3) Function B Condition 1 Arg 1 Number
	3				23	0	0	LB(x-3) Function B Condition 1 Arg 2 Source
	4					1	1	LB(x-3) Function B Condition 1 Arg 2 Number
	5					17	0	0

\* objects 3421h, 3521h

#### 4.4.52. 3x22h Logic Block (x-3) Function B Condition 2

Index	Subindex	Data Type	Access	PDO Mapping	Value Range	Default Value	Description	
3x22*	0	UINT8	RO	No	5	5	Number of subindexes	
	1		RW		Table	0	0	LB(x-3) Function B Condition 2 Arg 1 Source
	2					1	1	LB(x-3) Function B Condition 2 Arg 1 Number
	3				23	0	0	LB(x-3) Function B Condition 2 Arg 2 Source
	4					1	1	LB(x-3) Function B Condition 2 Arg 2 Number
	5					17	0	0

\* objects 3422h, 3522h

#### 4.4.53. 3x23h Logic Block (x-3) Function B Condition 3

Index	Subindex	Data Type	Access	PDO Mapping	Value Range	Default Value	Description	
3x23*	0	UINT8	RO	No	5	5	Number of subindexes	
	1		RW		Table 23	0	0	LB(x-3) Function B Condition 3 Arg 1 Source
	2					1	1	LB(x-3) Function B Condition 3 Arg 1 Number
	3				Table 23	0	0	LB(x-3) Function B Condition 3 Arg 2 Source
	4					1	1	LB(x-3) Function B Condition 3 Arg 2 Number
	5					0	0	LB(x-3) Function B Condition 3 Operator

\* objects 3423h, 3523h

#### 4.4.54. 3x31h Logic Block (x-3) Function C Condition 1

Index	Subindex	Data Type	Access	PDO Mapping	Value Range	Default Value	Description	
3x31*	0	UINT8	RO	No	5	5	Number of subindexes	
	1		RW		Table 23	0	0	LB(x-3) Function C Condition 1 Arg 1 Source
	2					1	1	LB(x-3) Function C Condition 1 Arg 1 Number
	3				Table 23	0	0	LB(x-3) Function C Condition 1 Arg 2 Source
	4					1	1	LB(x-3) Function C Condition 1 Arg 2 Number
	5					0	0	LB(x-3) Function C Condition 1 Operator

\* objects 3431h, 3531h

#### 4.4.55. 3x32h Logic Block (x-3) Function C Condition 2

Index	Subindex	Data Type	Access	PDO Mapping	Value Range	Default Value	Description	
3x32*	0	UINT8	RO	No	5	5	Number of subindexes	
	1		RW		Table 23	0	0	LB(x-3) Function C Condition 2 Arg 1 Source
	2					1	1	LB(x-3) Function C Condition 2 Arg 1 Number
	3				Table 23	0	0	LB(x-3) Function C Condition 2 Arg 2 Source
	4					1	1	LB(x-3) Function C Condition 2 Arg 2 Number
	5					0	0	LB(x-3) Function C Condition 2 Operator

\* objects 3432h, 3532h

#### 4.4.56. 3x33h Logic Block (x-3) Function C Condition 3

Index	Subindex	Data Type	Access	PDO Mapping	Value Range	Default Value	Description	
3x33*	0	UINT8	RO	No	5	5	Number of subindexes	
	1		RW		Table 23	0	0	LB(x-3) Function C Condition 3 Arg 1 Source
	2					1	1	LB(x-3) Function C Condition 3 Arg 1 Number
	3				Table 23	0	0	LB(x-3) Function C Condition 3 Arg 2 Source
	4					1	1	LB(x-3) Function C Condition 3 Arg 2 Number
	5					0	0	LB(x-3) Function C Condition 3 Operator

\* objects 3433h, 3533h

#### 4.4.57. 4000h Math Function Enable

Index	Subindex	Data Type	Access	PDO Mapping	Value Range	Default Value	Description
4000	0	UINT8	RO	No	2	2	Number of subindexes
	1...2		RW		0, 1	0	Math block #1 ... #2 enable

#### 4.4.58. 4021h Math Function Output Scaling 1 PV

Index	Subindex	Data Type	Access	PDO Mapping	Value Range	Default Value	Description
4021	0	UINT8	RO	No	2	2	Number of subindexes
	1...2	INT16	RW		INT16	0	Math block #1 ... #2 output scaling 1 PV

#### 4.4.59. 4023h Math Function Output Scaling 2 PV

Index	Subindex	Data Type	Access	PDO Mapping	Value Range	Default Value	Description
4023	0	UINT8	RO	No	2	2	Number of subindexes
	1...2	INT16	RW		INT16	0	Math block #1 ... #2 output scaling 1 PV

#### 4.4.60. 4030h Math Function Output Process Value

Index	Subindex	Data Type	Access	PDO Mapping	Value Range	Default Value	Description
4030	0	UINT8	RO	No	2	2	Number of subindexes
	1...2	INT16		Yes	INT16	0	Math block #1 ... #2 output process value

#### 4.4.61. 4032h Math Function Output PV Decimal Digits

Index	Subindex	Data Type	Access	PDO Mapping	Value Range	Default Value	Description
4032	0	UINT8	RO	No	2	2	Number of subindexes
	1...2		RW		0-3	2	Math block #1 ... #2 output PV decimal digits

#### 4.4.62. 4y00h Math #y Input Source

Index	Subindex	Data Type	Access	PDO Mapping	Value Range	Default Value	Description
4y00	0	UINT8	RO	No	5	5	Number of subindexes
	1...5		RW		0-15	0	Math block #y input source, see Table 23 for details.

#### 4.4.63. 4y01h Math #y Input Number

Index	Subindex	Data Type	Access	PDO Mapping	Value Range	Default Value	Description
4y01	0	UINT8	RO	No	5	5	Number of subindexes
	1...5		RW		depends on input source	0	Math block #y input number, see Table 23 for details.

#### 4.4.64. 4y03h Math #y Input Decimal Digits FV

Index	Subindex	Data Type	Access	PDO Mapping	Value Range	Default Value	Description
4y03	0	UINT8	RO	No	5	5	Number of subindexes
	1...5		RW		0-3	2	Math block #y input field value decimal digits

#### 4.4.65. 4y20h Math #y Input Scaling 1 FV

Index	Subindex	Data Type	Access	PDO Mapping	Value Range	Default Value	Description
4y20	0	UINT8	RO	No	5	5	Number of subindexes
	1...5	INT16	RW		INT16	0	Math block #y input field value scaling 1

#### 4.4.66. 4y22h Math #y Input Scaling 2 FV

Index	Subindex	Data Type	Access	PDO Mapping	Value Range	Default Value	Description
4y22	0	UINT8	RO	No	5	5	Number of subindexes
	1...5	INT16	RW		INT16	0	Math block #y input field value scaling 2

#### 4.4.67. 4y40h Math #y Input Gain

Index	Subindex	Data Type	Access	PDO Mapping	Value Range	Default Value	Description
4y40	0	UINT8	RO	No	5	5	Number of subindexes
	1...5	INT8	RW		INT8	100	Math block #y input gain

#### 4.4.68. 4y50h Math #y Operator

Index	Subindex	Data Type	Access	PDO Mapping	Value Range	Default Value	Description
4y50	0	UINT8	RO	No	5	5	Number of subindexes
	1...5		RW		0-14	0	Math block #y operator, see Table 22 for details

#### 4.4.69. 5010h Constant Field Value

Index	Subindex	Data Type	Access	PDO Mapping	Value Range	Default Value	Description
5010	0	UINT8	RO	No	12	12	Number of subindexes
	1	FLOAT32	RW		FLOAT32	0.0	User modifiable constant values to be used in custom control application.
	2				1.0		
	3				10.0		
	4				20.0		
	5				30.0		
	6				40.0		
	7				50.0		
	8				60.0		
	9				70.0		
	10				80.0		
	11				90.0		
	12				100.0		

#### 4.4.70. 5020h Power Supply FV

Index	Subindex	Data Type	Access	PDO Mapping	Value Range	Default Value	Description
5020	0	FLOAT32	RO	Yes	FLOAT32	0	Measured power supply voltage

#### 4.4.71. 5030h CPU Temperature FV

Index	Subindex	Data Type	Access	PDO Mapping	Value Range	Default Value	Description
5030	0	FLOAT32	RO	Yes	FLOAT32	0	Measured CPU internal temperature

#### 4.4.72. 5040h FD Field Value

Index	Subindex	Data Type	Access	PDO Mapping	Value Range	Default Value	Description
5040	0	UINT8	RO	No	3	3	Number of subindexes
	1	FLOAT32			FLOAT32	0	FD Field Value 1
	2				FD Field Value 2		
	3				FD Field Value 3		

#### 4.4.73. 5041h FD Set Threshold

Index	Subindex	Data Type	Access	PDO Mapping	Value Range	Default Value	Description
5041	0	UINT8	RO	No	3	3	Number of subindexes
	1	UINT16	RW		UINT16	1100	FD Set Threshold 1 (Temperature SET)
	2					500	FD Set Threshold 2 (VPS SET High)
	3					90	FD Set Threshold 3 (VPS SET Low)

#### 4.4.74. 5042h FD Clear Threshold

Index	Subindex	Data Type	Access	PDO Mapping	Value Range	Default Value	Description
5042	0	UINT8	RO	No	3	3	Number of subindexes
	1	UINT16	RW		UINT16	850	FD Set Threshold 1 (Temperature CLR)
	2					480	FD Set Threshold 2 (VPS CLR High)
	3					120	FD Set Threshold 3 (VPS CLR Low)

#### 4.4.75. 5050h FD Enable 3 Faults

Index	Subindex	Data Type	Access	PDO Mapping	Value Range	Default Value	Description
5050	0	UINT8	RW	No	0-7	7	Enable diagnostics: bit 0 – VPS bit 1 – CPU temperature

#### 4.4.76. 5051h FD Error Response Delay

Index	Subindex	Data Type	Access	PDO Mapping	Value Range	Default Value	Description
5051	0	UINT8	RO	No	3	3	Number of subindexes
	1	INT16	RW		0-600	10	FD Error response delay 1 (Temperature)
	2					10	FD Error response delay 2 (VPS)
	3					10	FD Error response delay 3

#### 4.4.77. 5120h VREF Control Source

Index	Subindex	Data Type	Access	PDO Mapping	Value Range	Default Value	Description
5120	0	UINT8	RO	No	9	9	Number of subindexes
	1...2		RW		0-15	0	Reference voltage output #1...#2 control source, see Table 23 for details.

#### 4.4.78. 5121h VREF Control Number

Index	Subindex	Data Type	Access	PDO Mapping	Value Range	Default Value	Description
5121	0	UINT8	RO	No	9	9	Number of subindexes
	1...2		RW		depends on Control Source	1	Reference voltage output #1...#2 control number, see Table 23 for details.

#### 4.4.79. 5555h Start In Operational Mode

Index	Subindex	Data Type	Access	PDO Mapping	Value Range	Default Value	Description
5555	0	UINT8	RW	No	0-3	0	0 – No action, wait NMT commands 1 – Start directly in operational mode 2 – Start in operational mode and send NMT for starting also other devices 3 – Start in operational mode and set PDS FSA to Enabled Mode.

#### 4.4.80. 5556h Start In Operational NMT Delay

Index	Subindex	Data Type	Access	PDO Mapping	Value Range	Default Value	Description
5556	0	UINT16	RW	No	0-65000	1000	Delay in milliseconds before sending the NMT message in case object 5555h is set to '2'.

## 5. Firmware Reflashing Instructions



**WARNING!** The firmware reflashing can be carried out only using Axiomatic Technologies **Electronic Assistant kit AX070502** and **250k CAN baud rate**.

**DO NOT START THE BOOTLOADER WITHOUT THE KIT!**

The Electronic Assistant compatible J1939 bootloader can be started by writing '1' to subindex 0 of the object 55AAh:

1. To do so, the object 55AAh can be accessed using CANopen tools or by sending the following SDO write message using CAN Assistant – Scope (assuming default node id of 0x7F):

ID	Len	D0	D1	D2	D3	D4	D5	D6	D7
67F	8	2F	AA	55	00	01	00	00	00

If everything is correct, the controller acknowledges the writing operation and activates software reset after the message is sent.

2. Run the Electronic Assistant (EA) software and connect to the CAN port. **The CAN baud rate needs to be changed to 250k because the bootloader and EA use J1939 messaging.** The user should see the following screen:

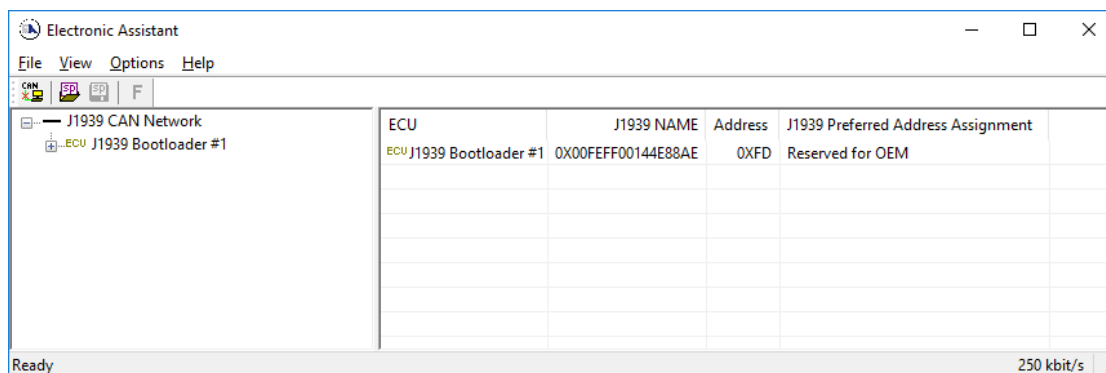

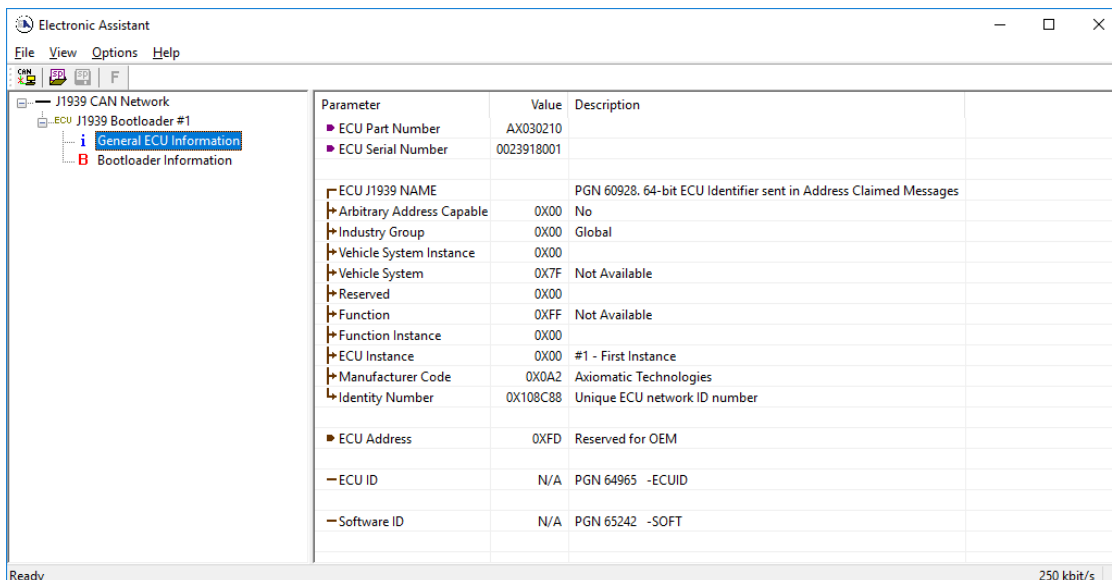

Note that the bootloader is NOT Arbitrary Address Capable. This means that if you want to have multiple bootloaders running simultaneously (not recommended) you would have to manually change the address for each one before activating the next, or there will be address conflicts. And only one ECU would show up as the bootloader. Once the 'active' bootloader returns to regular functionality, the other ECU(s) would have to be power cycled to re-activate the bootloader feature.

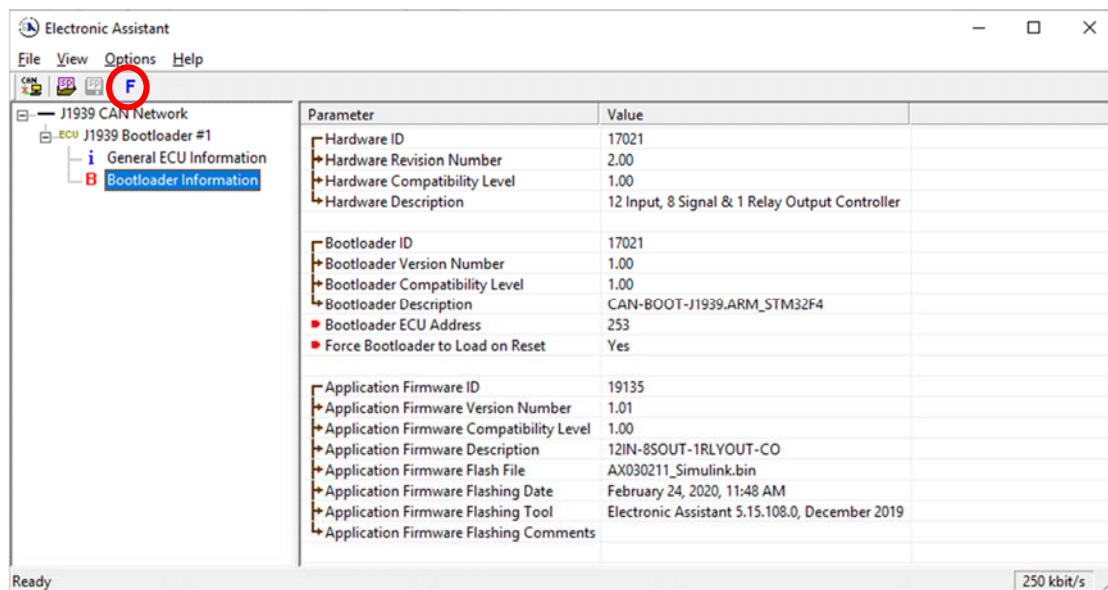

3. Select the **F** Flashing button and navigate to where you had saved the **AF-19135-x.xx.bin** (or equivalent) file sent from Axiomatic. (Note: only binary (.bin) files can be flashed using the EA tool.)
4. Once the Flash Application Firmware window opens, you can enter comments such as "Firmware upgraded by [Name]" if you so desire. This is not required, and you can leave the field blank if you do not want to use it.

Note: You do not have to date/time-stamp the file, as this is done automatically by the EA tool when you upload the new firmware.

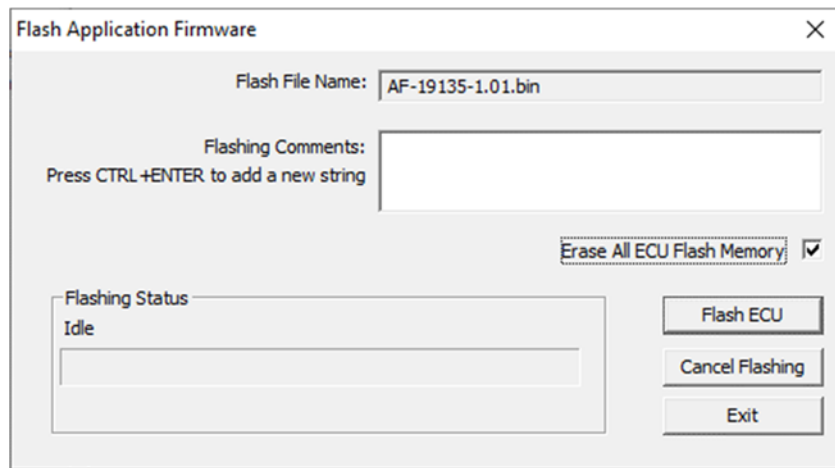

NOTE: It is good practice to tick the “Erase All ECU Flash Memory” box. Please note, that selecting this option will **erase ALL data stored in non-volatile flash**. It will also erase any configuration of the setpoints that might have been done to the ECU and reset all setpoints to their factory defaults. In case the controller contains custom settings, those settings need to be saved to PC before reflashing.

A progress bar will show how much of the firmware has been sent as the upload progresses. The more traffic there is on the J1939 network, the longer the upload process will take.

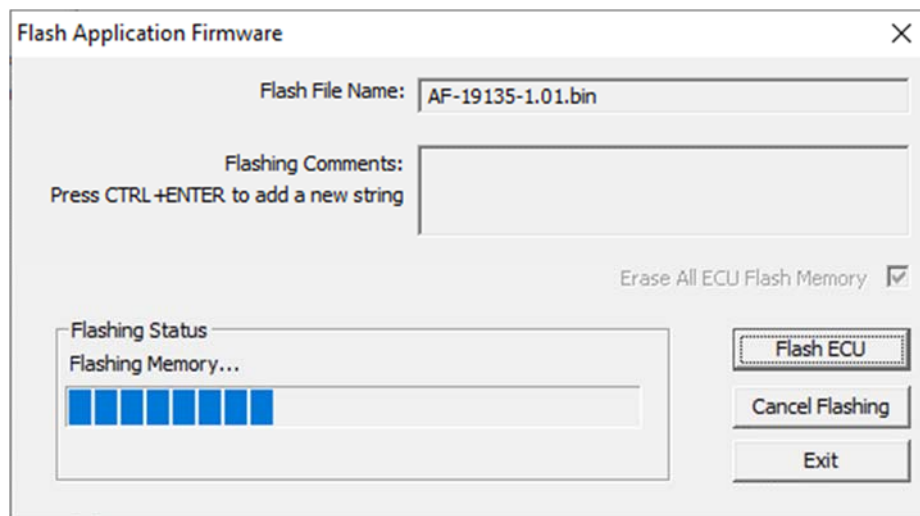

Once the firmware has finished uploading, a message will pop up indicating the successful operation. If you select to reset the ECU, the new version of the AX030211 application will start running, and the ECU will switch back to CANopen communications. Otherwise, the next time the ECU is power-cycled, the AX030211 application will run rather than the bootloader function.

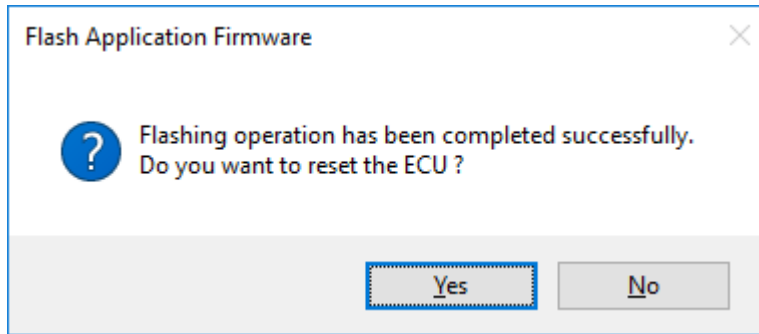

Note: If at any time during the upload the process is interrupted, the data is corrupted (bad checksum) or for any other reason the new firmware is not correct, i.e. bootloader detects that the file loaded was not designed to run on the hardware platform, the bad or corrupted application will not run. Rather, when the ECU is reset or power-cycled the **J1939 Bootloader** will continue to be the default application until valid firmware has been successfully uploaded into the unit.

## APPENDIX A - TECHNICAL SPECIFICATION

### Technical Specifications:

Specifications are indicative and subject to change. Actual performance will vary depending on the application and operating conditions. Users should satisfy themselves that the product is suitable for use in the intended application. All our products carry a limited warranty against defects in material and workmanship. Please refer to our Warranty, Application Approvals/Limitations and Return Materials Process as described on [www.axiomatic.com/service.html](http://www.axiomatic.com/service.html).

### Input Power

Power Supply Input - Nominal	<p>12, 24VDC nominal (8...36 VDC power supply range) Surge protection is provided.</p> <p>If batteries are used, an alternator or other battery-charging device is necessary to maintain a stable supply voltage. Central suppression of any surge events should be provided at the system level. The installation of the equipment must include overcurrent protection between the power source and the module by means of a series connection of properly rated fuses or circuit breakers. Input power switches must be arranged external to the Axiomatic Control Module.</p> <p>Power input wiring should be limited to 10 meters.</p>
Quiescent Current	<p>300 mA at 12 Vdc Typical 155 mA at 24 Vdc Typical Inrush does not exceed 500 mA.</p>
Protection	<p>Reverse polarity protection is provided. Power supply input section protects against transients, surges (per IEC 60533, Table 4) and short circuits and is isolated from inputs. Undervoltage protection is provided and hardware shuts down at 7.5Vdc. Over-voltage protection is provided, and hardware shuts down at 41Vdc.</p>

### Inputs

Universal Signal Inputs	<p>Up to 10 inputs are selectable by the user. All inputs, except for frequency, are sampled every 1ms. The user can select the type of filter that is applied to the measured data, before it is transmitted to the bus. The available filters are: Filter Type 0 = No Filter Filter Type 1 = Moving Average Filter Type 2 = Repeating Average</p>
Universal Signal Input Configuration	<p>Up to 10 inputs are available. Refer to Table 38.0. Each input can be configured for any one of the following options.</p> <ul style="list-style-type: none"> <li>• Disable input</li> <li>• 0...5VDC or 0...10VDC</li> <li>• 4...20mA or 0...20mA</li> <li>• Digital input</li> <li>• PWM signal</li> <li>• Pulse (Hz or RPM)</li> <li>• 16-bit Counter</li> </ul>
Input Protections	All inputs are protected against short circuits to GND or +Vcc.
Resistive Input	<p>One resistive type input 1 Ohm resolution +/- 1 % accuracy Self-calibrating in the range of 25 Ohms to 250 kOhms</p>
Analog GND	<p>10 Analog GND connections are provided. The grounds are connected internally in the module. 1 Resistive Input GND connection is provided.</p>
Voltage References	<p>2 +5V references (sourcing up to 100 mA) +/- 0.1% or 2 +10V references (sourcing up to 100 mA) +/-0.2%</p>
Input Scan Rate	1 mSec.
Digital Input	<p>One Digital Input Active High or Active Low Configurable 10 kΩpullup or pulldown resistor</p>

Input Type	Description
Analog Inputs	Up to 10 analog inputs are available. 0...5VDC or 0...10VDC 4...20mA or 0...20mA
Digital Inputs	Up to 10 digital inputs are available. The input accepted is active high or active low. Configurable 10 kΩpullup or pulldown resistor
PWM Signal Inputs	Up to 10 PWM inputs are available to interface to a PWM signal from an ECM, PLC, etc. PWM Signal Frequency: 0.50 – 10,000 Hz Amplitude: 5-12V PWM Duty Cycle: 0 to 100%
Pulse Inputs	Up to 10 pulse inputs are available. This input counts the number of pulses over the period of the measuring window setpoint and calculates the frequency of the pulses.  NOTE: The difference between Frequency and Counter mode is that the Frequency mode measures the number of pulses that occur in the Measuring Window period and calculates frequency, while the counter gives the period of time (in milliseconds) it takes for the number of pulses in the Measuring Window to be read at the input.
16-bit Counter Inputs	Up to ten 16-bit counter inputs are available. The input is configured to count pulses on the input until the value in the measuring window setpoint is reached.
Threshold Levels	For digital, PWM, pulse or counter inputs the voltage threshold levels are: <u>Input positive threshold (signal goes from low to high):</u> Min. 2.2V, typical 2.9V, max. 3.6V <u>Input negative threshold (signal goes from high to low):</u> Min. 1.2V, typical 1.7V, max. 2.3V
Input Accuracy	0-5V: +/- 1% 0-10V: +/- 1% 0-20mA or 4-20 mA: +/- 1% PWM, single channel: +/- 1% Frequency/RPM, single channel: +/- 1% 16-bit counter, single channel: +/- 3 mSec (@50 Hz)
Input Resolution	0-5V or 0-10V: 1 mV 0-20mA or 4-20 mA: 1μA
Input Impedance	Voltage 1 MOhm Current 124Ω PWM, frequency, 16-bit counter 1 MOhm

## Outputs

Analog Outputs	<p>8 Analog outputs 16-bit Digital to Analog User selectable (0-5V, 0-10V, +/-5V, +/-10V, 0-20 mA, 4-20 mA)</p> <p>Each analog output can be configured for one of the following options, and the properties and behavior of the output in each mode is described below in Table 2.0.</p> <table border="1"> <caption><i>Table 2.0 Analog Outputs</i></caption> <tbody> <tr> <td>0 to 5 Volts</td> <td>The output is configured to drive a voltage output in the range of 0V to 5V. If feedback messages are used to send the output value to the bus, then the message will be sent with a resolution of 1mV/bit, and a 0mV offset.</td> </tr> <tr> <td>-5 to 5 Volts</td> <td>The output is configured to drive a voltage output in the range of -5V to 5V. If feedback messages are used to send the output value to the bus, then the message will be sent with a resolution of 1mV/bit, and a -5000mV offset.</td> </tr> <tr> <td>0 to 10 Volts</td> <td>The output is configured to drive a voltage output in the range of 0V to 10V. If feedback messages are used to send the output value to the bus, then the message will be sent with a resolution of 1mV/bit, and a 0mV offset.</td> </tr> <tr> <td>-10 to 10 Volts</td> <td>The output is configured to drive a voltage output in the range of -10V to 10V. If feedback messages are used to send the output value to the bus, then the message will be sent with a resolution of 1mV/bit, and a -10000mV offset.</td> </tr> <tr> <td>0(4) to 20 Milliamps</td> <td>The output is configured to source a current in the range of 0(4)mA to 20mA. If feedback messages are used to send the output value to the bus, then the message will be sent with a resolution of 1uA/bit, and a 0uA offset. Compliance voltage is up to 32Vdc.</td> </tr> </tbody> </table>	0 to 5 Volts	The output is configured to drive a voltage output in the range of 0V to 5V. If feedback messages are used to send the output value to the bus, then the message will be sent with a resolution of 1mV/bit, and a 0mV offset.	-5 to 5 Volts	The output is configured to drive a voltage output in the range of -5V to 5V. If feedback messages are used to send the output value to the bus, then the message will be sent with a resolution of 1mV/bit, and a -5000mV offset.	0 to 10 Volts	The output is configured to drive a voltage output in the range of 0V to 10V. If feedback messages are used to send the output value to the bus, then the message will be sent with a resolution of 1mV/bit, and a 0mV offset.	-10 to 10 Volts	The output is configured to drive a voltage output in the range of -10V to 10V. If feedback messages are used to send the output value to the bus, then the message will be sent with a resolution of 1mV/bit, and a -10000mV offset.	0(4) to 20 Milliamps	The output is configured to source a current in the range of 0(4)mA to 20mA. If feedback messages are used to send the output value to the bus, then the message will be sent with a resolution of 1uA/bit, and a 0uA offset. Compliance voltage is up to 32Vdc.
0 to 5 Volts	The output is configured to drive a voltage output in the range of 0V to 5V. If feedback messages are used to send the output value to the bus, then the message will be sent with a resolution of 1mV/bit, and a 0mV offset.										
-5 to 5 Volts	The output is configured to drive a voltage output in the range of -5V to 5V. If feedback messages are used to send the output value to the bus, then the message will be sent with a resolution of 1mV/bit, and a -5000mV offset.										
0 to 10 Volts	The output is configured to drive a voltage output in the range of 0V to 10V. If feedback messages are used to send the output value to the bus, then the message will be sent with a resolution of 1mV/bit, and a 0mV offset.										
-10 to 10 Volts	The output is configured to drive a voltage output in the range of -10V to 10V. If feedback messages are used to send the output value to the bus, then the message will be sent with a resolution of 1mV/bit, and a -10000mV offset.										
0(4) to 20 Milliamps	The output is configured to source a current in the range of 0(4)mA to 20mA. If feedback messages are used to send the output value to the bus, then the message will be sent with a resolution of 1uA/bit, and a 0uA offset. Compliance voltage is up to 32Vdc.										

Output Accuracy	Voltage Output: +/- 0.2% Current Output: +/- 0.4%
Output Resolution	Voltage: 1 mV Current: 0.5 $\mu$ A
Output Grounds	8 Analog Output GNDs are connected internally.
Output Adjust Rate	Approximately 1 mSec.
Short Circuit Protection	Individual short circuit protection is provided.
Other Protection	Each output is protected against shorts to GND or +Vcc.
Output Short Circuit Protection	Fully protected (all physical pins, all inputs, outputs and power)
Relay Output	1 Form C Relay NC 3 contact pins per output Maximum electrical endurance at contact: 0.25A @ 250Vac 0.5A @ 125Vac 0.24A @ 125Vdc 2A @ 30Vdc

## General Specifications

Microprocessor	STM32F407ZG, ARM Cortex M4 32-bit, 1 Mbyte Flash Memory, 196 Kbyte SRAM												
Control Logic	Standard embedded software is provided. <i>Refer to the user manual for details.</i> (Application-specific control logic is available on request.)												
CAN Interface	1 CANopen® port Digital isolation is provided for the CAN line.												
Isolation	300Vrms Isolation for the CAN port												
User Interface	EDS file												
Reflashing	Axiomatic Electronic Assistant, AX070502												
Operating Conditions	-40 to 85°C (-40 to 185°F)												
Protection	IP67, Unit is conformally coated in the housing. Marine Type Approval Testing to IP56.												
Weight	2.20 lbs. (0.99 kg)												
Compliance	CE marking EMC compliant – Marine Type Approval testing Marine Type Approval – RINA												
Vibration	MIL-STD-202G, Test 204D and 214A (Sine and Random) 10 g peak (Sine); 7.86 Grms peak (Random)												
Shock	MIL-STD-202G, Test 213B, 50 g												
Enclosure, Dimensions and Pin Out	Aluminum extrusion with stainless steel end plates. Gaskets are open cell neoprene. For dimensions and pin out, Refer to the Installation Instructions section.												
Mating Plug Kit AX070200	Mating Plug Kit P/N: <b>AX070200</b> This kit includes the following items. These items are also available from a local Deutsch IPD distributor. <i>NB. The sealing plugs are only needed in cases where not all of the 40 pins are used.</i> A crimping tool from Deutsch IPD is required to connect wiring to the sockets, P/N: HDT 48-00 or equivalent (not supplied). <table border="1" data-bbox="488 1560 1230 1812"> <thead> <tr> <th><b>TE Deutsch P/N:</b></th> <th><b>Description:</b></th> </tr> </thead> <tbody> <tr> <td>0462-201-16141</td> <td>48 16AWG SOCKETS SOLID 16-20AWG WIRE 6mm</td> </tr> <tr> <td>114017</td> <td>24 SEALING PLUGS SIZE 12-16 CAVITIES 12-18 AWG</td> </tr> <tr> <td>DRC16-40S</td> <td>40-PIN PLUG, No Key</td> </tr> <tr> <td>DT06-08SA</td> <td>DT SERIES PLUG 8 CONTACTS</td> </tr> <tr> <td>W8S</td> <td>WEDGELOCK FOR DT 8 PIN PLUG</td> </tr> </tbody> </table>	<b>TE Deutsch P/N:</b>	<b>Description:</b>	0462-201-16141	48 16AWG SOCKETS SOLID 16-20AWG WIRE 6mm	114017	24 SEALING PLUGS SIZE 12-16 CAVITIES 12-18 AWG	DRC16-40S	40-PIN PLUG, No Key	DT06-08SA	DT SERIES PLUG 8 CONTACTS	W8S	WEDGELOCK FOR DT 8 PIN PLUG
<b>TE Deutsch P/N:</b>	<b>Description:</b>												
0462-201-16141	48 16AWG SOCKETS SOLID 16-20AWG WIRE 6mm												
114017	24 SEALING PLUGS SIZE 12-16 CAVITIES 12-18 AWG												
DRC16-40S	40-PIN PLUG, No Key												
DT06-08SA	DT SERIES PLUG 8 CONTACTS												
W8S	WEDGELOCK FOR DT 8 PIN PLUG												

Grounding	<p>Protective Earth (PE) must be connected to the grounding stud to reduce the risk of electric shock. The conductor providing the connection should have a ring lug and wire larger than or equal to 4 mm<sup>2</sup> (12 AWG). The ring lug should be placed between the nut and a star washer. (To secure the ground strap, use an 8-32 "K-LOK" locknut, stainless steel, 3/8" O.D.)</p> <p>All chassis grounding should go to a single ground point designated for the machine and all related equipment.</p> <p>The ground strap that provides a low impedance path for EMI should be a ½ inch wide, flat, hollow braid, no more than 12 inches long with a suitable sized ring lug for the module's grounding lug. It may be used in place of the PE grounding conductor and would then perform both PE and EMI grounding functions.</p>
Shielding	<p>The CAN wiring should be shielded using a twisted conductor pair. All wire shields should be terminated externally to the grounding lug on the mounting foot. The input wires should not be exposed for more than 2 inches (50 mm) without shielding. Shields can be ac grounded at one end and hard grounded at the opposite end to improve shielding. If the module is installed in a cabinet, shielded wiring can be terminated at the cabinet (earth ground), at the entry to the cabinet or at the module.</p>
CAN Wiring	<p>The CAN port is electrically isolated from all other circuits. The isolation is SELV rated with respect to product safety requirements. Refer to the CAN specification for more information.</p> <p>Use CAN compatible cabling.</p> <p>Shielded CAN cable is required. The module provides the CAN port shield connection ac coupled to chassis ground. The chassis ground stud located on the mounting foot must be tied directly to Earth Ground.</p>
Network Construction	<p>Axiomatic recommends that multi-drop networks be constructed using a "daisy chain" or "backbone" configuration with short drop lines.</p>
Termination	<p>It is necessary to terminate the network with external termination resistors. The resistors are 120 Ohm, 0.25W minimum, metal film or similar type. They should be placed between CAN_H and CAN_L terminals at both ends of the network.</p>
Mounting	<p>Mounting ledges include holes sized for ¼ inch or M6 bolts. The bolt length will be determined by the end-user's mounting plate thickness. Typically, ¾ inch (20 mm) is adequate.</p> <p>If the module is mounted without an enclosure, it should be mounted vertically with connectors facing left and right to reduce likelihood of moisture entry.</p> <p>The CAN wiring is considered intrinsically safe. The power wires are not considered intrinsically safe and so in hazardous locations, they need to be located in conduit or conduit trays at all times. The module must be mounted in an enclosure in hazardous locations for this purpose.</p> <p>No wire or cable harness should exceed 30 meters in length. The power input wiring should be limited to 10 meters.</p> <p>All field wiring should be suitable for the operating temperature range of the module.</p> <p>Install the unit with appropriate space available for servicing and for adequate wire harness access (6 inches or 15 cm) and strain relief (12 inches or 30 cm).</p>