

**4 Universal Signal Inputs, 5V/8V Voltage Reference,
CAN Controller with SAE J1939**

USER MANUAL

P/N: AX030440

ACRONYMS

ACK	Positive Acknowledgement
CSR	CAN Status Report
DM	Diagnostic Message (from SAE J1939 standard)
DTC	Diagnostic Trouble Code
FMI	Failure Mode Identifier
OC	Occurrence Count
EA	Axiomatic Electronic Assistant (Service Tool for Axiomatic ECUs)
ECU	Electronic Control Unit (from SAE J1939 standard)
MAP	Memory Access Protocol
NAK	Negative Acknowledgement
PDU1	A format for messages that are to be sent to a destination address, either specific or global
PDU2	A format used to send information that has been labeled using the Group Extension technique and does not contain a destination address.
PGN	Parameter Group Number (from SAE J1939 standard)
PropB	Message that uses a Proprietary B PGN
SPN	Suspect Parameter Number (from SAE J1939 standard)

TABLE OF CONTENTS

1.1. INTRODUCTION TO AX030440 FEATURES	4
1.2. J1939 NETWORK – DIAGNOSTIC BROADCAST	4
1.3. UNIVERSAL INPUT	5
1.3.1. Control Sources	5
1.3.2. Universal Input Type	5
1.3.3. Universal Input Range	5
1.3.4. Universal Input Analog Filter.....	6
1.3.5. Universal Input Error and Range	6
1.3.6. Universal Input Digital Input Parameters	6
1.3.7. Universal Input Frequency/PWM Parameters	7
1.3.8. Universal Input Data Filter	8
1.3.9. Universal Input Diagnostic Parameters	8
1.4. MISCELLANEOUS	9
1.5. DIAGNOSTICS	9
1.6. CONSTANT DATA	11
1.7. MATH FUNCTION BLOCK	11
1.8. PROGRAMMABLE LOGIC FUNCTION BLOCK	12
1.9. LOOKUP TABLE FUNCTION BLOCK	13
1.10. CONDITIONAL BLOCK	14
1.11. SET / RESET LATCH FUNCTION BLOCK	15
1.12. CAN TRANSMIT FUNCTION BLOCK	15
1.13. CAN RECEIVE FUNCTION BLOCK	16
2. OVERVIEW OF J1939 FEATURES	18
2.1. INTRODUCTION TO SUPPORTED MESSAGES	18
2.2. J1939 NAME, ADDRESS AND SOFTWARE ID	19
2.2.1. J1939 Name.....	19
2.2.2. ECU Address	19
2.2.3. Software Identifier	20
3. ECU SETPOINTS ACCESSED WITH ELECTRONIC ASSISTANT	21
3.1. J1939 NETWORK SETPOINTS	21
3.2. UNIVERSAL INPUT SETPOINTS	21
3.3. MISCELLANEOUS SETPOINTS	22
3.4. DIAGNOSTIC SETPOINTS	23
3.5. CONSTANT DATA LIST SETPOINTS	24
3.6. MATH FUNCTIONAL BLOCK SETPOINTS	24
3.7. PROGRAMMABLE LOGIC BLOCK SETPOINTS	26
3.8. LOOKUP TABLE SETPOINTS	28
3.9. CONDITIONAL BLOCK SETPOINTS	29
3.10. SET-RESET LATCH BLOCK	30
3.11. CAN TRANSMIT SETPOINTS	31
3.12. CAN RECEIVE SETPOINTS	33
3.13. 5V TO 8V REFERENCE SWITCH	34
4. REFLASHING OVER CAN WITH ELECTRONIC ASSISTANT BOOTLOADER	35
4.1. PREREQUISITES	35
4.2. RE-FLASHING PROCEDURE	35
5. INSTALLATION INSTRUCTIONS	40
6. TECHNICAL SPECIFICATIONS	41
Reverse polarity protection up to -100V	41
User selectable	41
+5V/+8V, 100 mA, 2% reference voltage output.....	41
7. VERSION HISTORY	43

GENERAL INFORMATION

1.1. Introduction to AX030440 Features

The 4UIN-8VREF-2CAN electronic control unit (ECU) is designed to provide a simple interface for Universal Inputs over a J1939 CAN Network, to be used in a power generator set or industrial environment. The hardware supports 4 Universal Inputs. The universal inputs accept voltage, current, resistance, frequency, PWM duty cycle, and discrete voltage levels. A +8V or +5V reference voltage output can be used to power external sensors/equipment. The voltage reference level can be configured using EA.

The ECU has been designed to allow the maximum amount of versatility to optimize the performance of the machine. Numerous configurable variables, called setpoints, have been provided which are accessible using Axiomatic Technologies' Electronic Assistant. Information about the setpoint defaults and ranges is outlined in Section 3. The EA communicates with the controller over J1939 CAN bus and uses Memory Access Protocol (MAP) to read/write each setpoint. Once the ECU has been setup as desired, the setpoints can be saved to a file, and flashed into other controllers using EA.

The ECU is an arbitrary address capable ECU, which can perform dynamic address allocation at the run time. It also provides all necessary network support required by the J1939 standard.

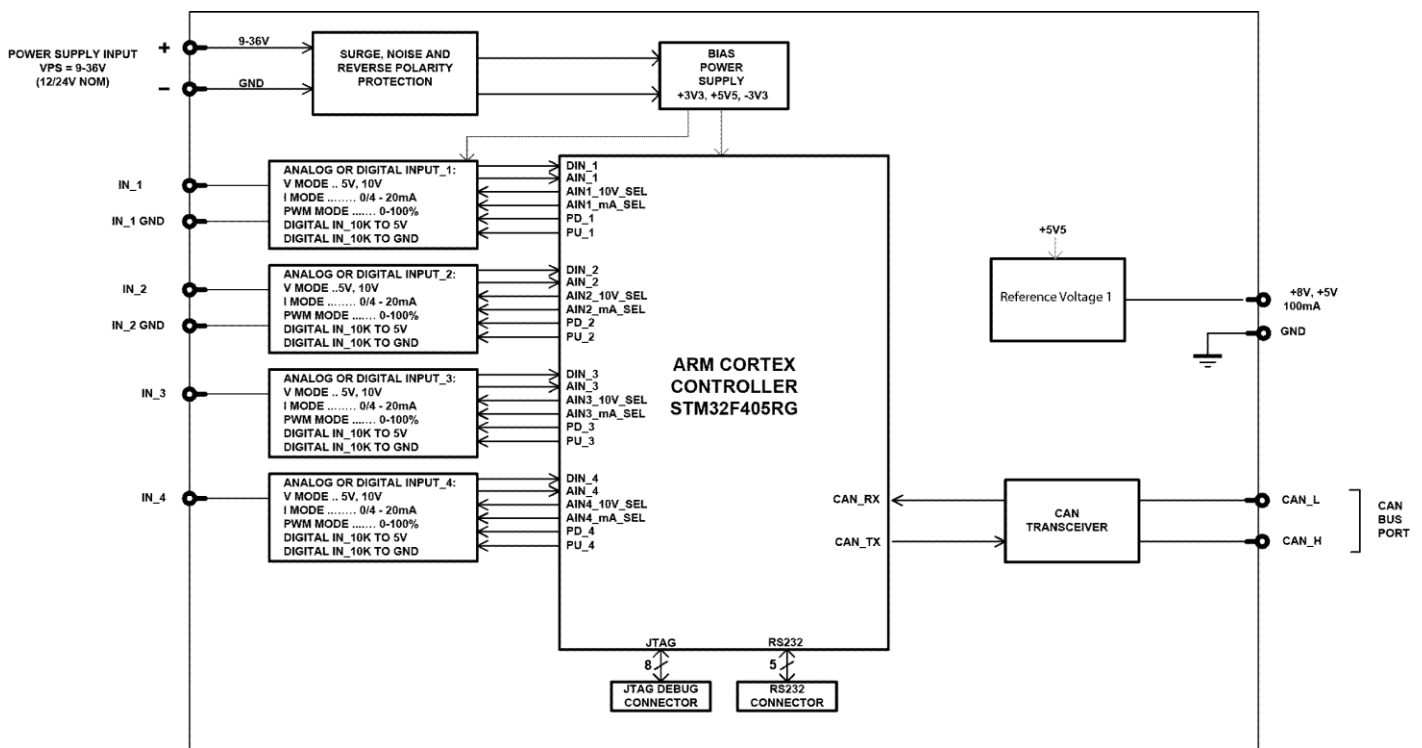

BLOCK DIAGRAM

1.2. J1939 Network – Diagnostic Broadcast

Diagnostic messages are triggered by the internal function blocks and then broadcasted on the CAN bus network. However, in some applications this broadcast may not be required and so the

user has the option to disable or enable this feature. Section 1.4 and 3.3 shows the configuration of this feature by using the Electronic Assistant tool.

1.3. Universal Input

1.3.1. Control Sources

The different function blocks in the ECU are commanded by a set of Control Sources. This section lists the different available control sources for these functions and their respective ranges.

Value	Meaning	Source Range
0	Control Not Used	[0]
1	Universal Input	[1...4]
2	CAN Receive	[1...10]
3	Constant Data	[1...15]
4	Math Block	[1...5]
5	Programmable Logic Block	[1...3]
6	Lookup Table	[1...10]
7	Conditional Logic Block	[1...10]
8	Set-Reset Latch	[1...5]
9	Power Supply Reading	[1]
10	Internal Temperature Reading	[1]

Table 1: Control Sources

While these sources are available for all functional blocks, it is not recommended to use Constant Data as a source in the Set-Reset Latch block.

1.3.2. Universal Input Type

The **Input Type** parameter allows the user to select how the controller responds to the behaviour of the input. Table 2 shows the different options for each input.

Value	Meaning
0	Input Disabled
1	Voltage Input
2	Current Input
3	Digital Input
4	Frequency Input
5	PWM Input
6	Resistive Input

Table 2: Universal Input Types

1.3.3. Universal Input Range

The **Input Range** parameter is used to specify the expected range of Voltage or Current inputs. It is disabled for other input types. Table 3 shows the options available for this parameter when a Voltage Input is selected, and Table 4 show the options for a Current Input.

Value	Meaning
0	0 - 5V Analog Input
1	0 - 10V Analog Input

Table 3: Voltage Input Ranges

Value	Meaning
0	0 - 20mA Analog Input
1	4 - 20mA Analog Input

Table 4: Current Input Ranges

Also, the **Pull Up/Down** parameter can be set when the **Input Type** is set to Voltage Input and **Input Range** is set to 0-5V Analog Input. It allows the ECU to work in two modes for this input range: 5V in High Impedance and 5V with 10kOhm Impedance.

*Note: It is only possible to set the pull-down resistor either high or low if the **Input Type** is set to Input Voltage. If 10kOhm pull-down is disabled, the ECU will run in 5V in High Impedance mode. Setting the pull-up resistor option is not available for this input type.*

1.3.4. Universal Input Analog Filter

The **Analog Filter** parameter is only applicable when a voltage or a current type is being measured. In these cases, the ADC will automatically filter as per Table 5, and is set for 50Hz noise rejection by default.

Value	Meaning
0	Input Filter Off
1	Filter 50Hz
2	Filter 60Hz
3	Filter 50Hz and 60Hz

Table 5: Analog Filter

1.3.5. Universal Input Error and Range

Each Input can have different Input Ranges which can be configured. The **Range Min** and **Range Max** parameters are used to set the range for the input. The **Error Min** and **Error Max** parameters are used to set when the accompanying diagnostic message will be triggered.

1.3.6. Universal Input Digital Input Parameters

If the Input is configured as a Digital Input, the following setpoints become available to help configure the input.

The **Pull Up/Down** parameter is used to change the configuration of internal resistors with the following options.

Value	Meaning
0	No Pull
1	Pull Up Network
2	Pull Down Network

Table 6: Digital Input Pull Up/Down

The **Logic Type** parameter is used to determine how the input is received when configured as a Digital Input.

Value	Meaning
0	Input Not Implemented
1	Normal Logic
2	Inverse Logic
3	Latched Logic
4	Inverse Latched Logic

Table 7: Digital Input Logic Type

By default, the *Normal Logic* type is used for the digital input.

In *Normal Logic* mode, the input state is 1 in case the input signal is interpreted as an ON-signal. The input state turns 0 if the input signal is interpreted as an OFF-signal.

For the *Inverse Logic* type, the opposite behavior applies. If the input signal is ON, the state turns 0 and if the input signal is OFF, the state turns 1.

Setting the Input to *Latched Logic*, the input state is toggled between 1 and 0 every time the input signal of the respective digital input changes from OFF to ON.

In *Inverse Latched Logic* mode, the opposite behaviour applies. The input state toggles between 1 and 0 every time the input signal changes from ON to OFF.

The Digital Input **Debounce Time** parameter is a useful parameter in cases where the digital input signal coming into the controller is noisy. Figure 1 shows how the Debounce Time helps detect a correct input signal.

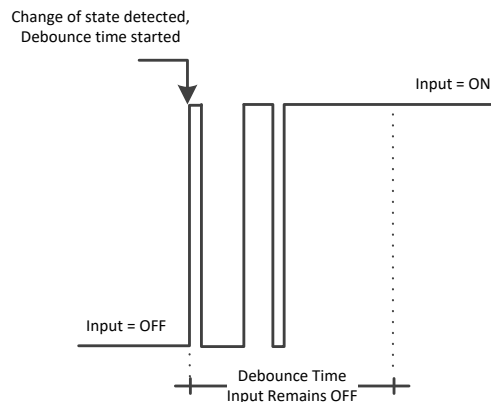

Figure 1: Digital Input Debounce Time

1.3.7. Universal Input Frequency/PWM Parameters

If the Input is configured as either a Frequency Input or a PWM Input, then the following parameters become available.

The **PWM Debounce Filter** is applied to the input before the state is read by the processor. The options for this setpoint are shown in Table 8.

Value	Meaning
0	Filter Disabled
1	Filter 111ns
2	Filter 1.78 us
3	Filter 14.22 us

Table 8: PWM Debounce Filter

The **Number of Pulses per Revolution** parameter, if greater than 0, will convert a frequency input into RPM instead of Hertz, based on the value entered.

1.3.8. Universal Input Data Filter

All analog inputs (Voltage or Current) can be further filtered once the raw data has been measured. The **Data Filter Type** parameter determines what kind of filter is used per Table 9. By default, additional software filtering is disabled.

Value	Meaning
0	No Filter
1	Moving Average
2	Repeating Average

Table 9: Data Filter Type

The **Data Filter Constant** is used with all types of filters as per the formulas below:

Calculation with no filter:

$$\text{Value} = \text{Input}$$

The data is simply a ‘snapshot’ of the latest value measured by the ADC or timer.

Calculation with the moving average filter:

$$\text{Value}_N = \text{Value}_{N-1} + \frac{(\text{Input} - \text{Value}_{N-1})}{\text{FilterConstant}}$$

This filter is called every 1ms

Calculation with the repeating average filter:

$$\text{Value} = \frac{\sum \text{Input}_N}{N}$$

At every reading of the input value, it is added to the sum. At every Nth read, the sum is divided by N, and the result is the new input value. The value and counter will be set to zero for the next read. This filter is called every 1ms.

1.3.9. Universal Input Diagnostic Parameters

The **Error Clear Hysteresis** is used to set the hysteresis value at which an input error can be cleared.

1.4. Miscellaneous

The Miscellaneous function block contains various parameters that affect the general diagnostic performance of the ECU.

The **Undervoltage Threshold**, **Overvoltage Threshold**, and **Shutdown Temperature** setpoints are used to set the limits for when their respective diagnostic messages are triggered.

Lastly, the **CAN Diagnostic Setting** parameter is used to control all diagnostics with one general setting for CAN Interface. This can be used to disable diagnostics entirely, only transmit messages without a blank SPN, or transmit diagnostic messages normally.

1.5. Diagnostics

The Diagnostic function block includes twelve faults, each representing a diagnostic message that the ECU is able to produce. Each Universal Input has a Voltage Out of Range Low and Voltage Out of Range High Fault. The remaining faults cover VPS Overvoltage and Undervoltage, Overtemperature, and other faults.

If and only if the **Event Generates a DTC in DM1** parameter is set to true will the other setpoints in the function block be enabled. They are all related to the data that is sent to the J1939 network as part of the DM1 message, Active Diagnostic Trouble Codes.

A Diagnostic Trouble Code (DTC) is defined by the J1939 standard as a 4-byte value which is a combination of:

SPN	Suspect Parameter Number	(first 19 bits of the DTC, LSB first)
FMI	Failure Mode Identifier	(next 5 bits of the DTC)
CM	Conversion Method	(1 bit, always set to 0)
OC	Occurrence Count	(7 bits, number of times the fault has happened)

In addition to supporting the DM1 message, the Controller also supports

DM2	Previously Active Diagnostic Trouble Codes	Sent only on request
DM3	Diagnostic Data Clear/Reset of Previously Active DTCs	Done only on request
DM11	Diagnostic Data Clear/Reset for Active DTCs	Done only on request

So long as even one Diagnostic function block has **Event Generates a DTC in DM1** set to true, the Controller will send the DM1 message every one second, regardless of whether there are any active faults, as recommended by the standard. While there are no active DTCs, the Controller will send the “No Active Faults” message. If a previously active DTC becomes inactive, a DM1 will be sent immediately to reflect this. As soon as the last active DTC goes inactive, it will send a DM1 indicating that there are no more active DTCs.

If there is more than one active DTC at any given time, the regular DM1 message will be sent using a multipacket Broadcast Announce Message (BAM). If the controller receives a request for a DM1 while this is true, it will send the multipacket message to the Requester Address using the Transport Protocol (TP).



At power up, the DM1 message will not be broadcast until after a 5 second delay. This is done to prevent any power up or initialization conditions from being flagged as an active error on the network.

The Diagnostic function block has a setpoint **Event Cleared Only by DM11**. By default, this is set to false, which means that as soon as the condition that caused an error flag to be set goes away, the DTC is automatically made Previously Active, and is no longer included in the DM1 message. However, when this setpoint is set to true, even if the flag is cleared, the DTC will not be made inactive, so it will continue to be sent on the DM1 message. Only when a DM11 has been requested will the DTC go inactive. This feature may be useful in a system where a critical fault needs to be clearly identified as having happened, even if the conditions that caused it went away.

In addition to all the active DTCs, another part of the DM1 message is the first byte, which reflects the Lamp Status. Each Diagnostic function block has the setpoint **Lamp Set by Event in DM1** which determines which lamp will be set in this byte while the DTC is active. The J1939 standard defines the lamps as *'Malfunction'*, *'Red Stop'*, *'Amber, Warning'* or *'Protect'*. By default, the *'Amber, Warning'* lamp is typically the one set by any active fault.

By default, every Diagnostic function block has associated with it a proprietary SPN. However, this setpoint **SPN for Event used in DTC** is fully configurable by the user should they wish it to reflect a standard SPN define in J1939-71 instead. If the SPN is change, the OC of the associate error log is automatically reset to zero.

Every Diagnostic function block also has associated with it a default FMI. The only setpoint for the user to change the FMI is **FMI for Event used in DTC**, even though some Diagnostic function blocks can have both high and low errors. In those cases, the FMI in the setpoint reflects that of the low-end condition, and the FMI used by the high fault will be determined per Table 10. If the FMI is changed, the OC of the associate error log is automatically reset to zero.

FMI for Event used in DTC – Low Fault	Corresponding FMI used in DTC – High Fault
FMI=1, Data Valid But Below Normal Operational Range – Most Severe Level	FMI=0, Data Valid But Above Normal Operational Range – Most Severe Level
FMI=4, Voltage Below Normal, Or Shorted To Low Source	FMI=3, Voltage Above Normal, Or Shorted To High Source
FMI=5, Current Below Normal Or Open Circuit	FMI=6, Current Above Normal Or Grounded Circuit
FMI=17, Data Valid But Below Normal Operating Range – Least Severe Level	FMI=15, Data Valid But Above Normal Operating Range – Least Severe Level
FMI=18, Data Valid But Below Normal Operating Range – Moderately Severe Level	FMI=16, Data Valid But Above Normal Operating Range – Moderately Severe Level
FMI=21, Data Drifted Low	FMI=20, Data Drifted High

Table 10: Low Fault FMI versus High Fault FMI



If the FMI used is anything other than one of those in Table 10, then both the low and the high faults will be assigned the same FMI. This condition should be avoided, as the log will still use different OC for the two types of faults, even though they will be reported the same in the DTC.

When the fault is linked to a DTC, a non-volatile log of the occurrence count (OC) is kept. As soon as the controller detects a new (previously inactive) fault, it will start decrementing the **Delay Before Sending DM1** timer for the Diagnostic function block. If the fault has remained present during the delay time, then the controller will set the DTC to active, and it will increment the OC in the log. A DM1 will immediately be generated that includes the new DTC. The timer is provided so that intermittent faults do not overwhelm the network as the fault comes and goes, since a DM1 message would be sent every time the fault shows up or goes away.

1.6. Constant Data

The Constant Data Block contains four configurable constant data setpoints which can be used as a control source for other functions. While they are available as a control source to all functions, it is recommended not to use constant data as a control source for the Set-Reset Latch Block.

1.7. Math Function Block

There are four mathematical function blocks that allow the user to define basic algorithms. A math function block can take up to six input signals. Each input is then scaled according to the associated limit and scaling setpoints.

Inputs are converted into percentage value based on the “**Input X Minimum**” and “**Input X Maximum**” values selected. For additional control the user can also adjust the “**Input X Decimal Digits**” setpoint to increase the resolution of the input data and the min and max values.

A mathematical function block includes three selectable functions, in which each implements equation $A \text{ operator } B$, where A and B are function inputs and operator is function selected with a setpoint “**Math Function X**”. Setpoint options are presented in Table 11. The functions are connected together, so that result of the preceding function goes into Input A of the next function. Thus Function 1 has both Input A and Input B selectable with setpoints, where Functions 2 to 4 have only Input B selectable. Input is selected by setting “**Function X Input Y Source**” and “**Function X Input Y Number**”. If “**Function X Input B Source**” is set to 0 ‘Control not used’ signal goes through function unchanged.

$$\text{Math Block Output} = (((A1 \text{ op1 } B1) \text{ op2 } B2) \text{ op3 } B3) \text{ op4 } B4$$

0	$=$, True when InA equals InB
1	\neq , True when InA not equal InB
2	$>$, True when InA greater than InB
3	\geq , True when InA greater than or equal InB
4	$<$, True when InA less than InB
5	\leq , True when InA less than or equal InB
6	OR, True when InA or InB is True
7	AND, True when InA and InB are True
8	XOR, True when either InA or InB is True, but not both

9	<i>+</i> , Result = InA plus InB
10	<i>-</i> , Result = InA minus InB
11	<i>x</i> , Result = InA times InB
12	<i>/</i> , Result = InA divided by InB
13	<i>MIN</i> , Result = Smallest of InA and InB
14	<i>MAX</i> , Result = Largest of InA and InB

Table 11: Math function X Operator Options

For logic operations (6, 7, and 8) scaled input greater than or equal to 1 is treated as TRUE. For logic operations (0 to 8), the result of the function will always be 0 (FALSE) or 1 (TRUE). For the arithmetic functions (9 to 14), it is recommended to scale the data such that the resulting operation will not exceed full scale (0 to 100%) and saturate the output result.

When dividing, a zero divider will always result in a 100% output value for the associated function. Lastly the resulting mathematical calculation, presented as a percentage value, can be scaled into the appropriate physical units using the “**Math Output Minimum Range**” and “**Math Output Maximum Range**” setpoints. These values are also used as the limits when the Math Function is selected as the input source for another function block.

1.8. Programmable Logic Function Block

The Programmable Logic Function Block is a powerful tool. Programmable Logic can be linked to up to three Lookup Tables, any of which would be selected only under given conditions. Thus, the output of a Programmable Logic at any given time will be the output of the Lookup Table selected by the defined logic. Therefore, up to three different responses to the same input, or three different responses to different inputs, can become the input to another function block.

In order to enable any one of the Programmable Logic blocks, the “**Logic Enabled**” setpoint must be set to ‘True’. By default, all Logic blocks are disabled.

The three associated tables are selected by setting “**Table Number X**” setpoint to desired Lookup Table number, for example selecting 1 would set Lookup Table 1 as TableX.

For each TableX there are three conditions that define the logic to select the associated Lookup Table as Logic output. Each condition implements function *Argument1 Operator Argument2* where Operator is logical operator defined by setpoint “**Table X – Condition Y Operator**”. Setpoint options are listed in Table 12. Condition arguments are selected with “**Table X – Condition Y Argument Z Source**” and “**Table X – Condition Y Argument Z Number**” setpoints. If ‘0 – Control not Used’ option is selected as “**Table x – Condition Y Argument Z Source**” the argument is interpreted as 0.

0	<i>=</i> , Equal
1	<i>!=</i> , Not Equal
2	<i>></i> , Greater Than
3	<i>>=</i> , Greater Than or Equal
4	<i><</i> , Less Than
5	<i><=</i> , Less Than or Equal

Table 12: Table X – Condition Y Operator Options

The three conditions are evaluated and if the result satisfies logical operation defined with “**Logical Operator X**” setpoint, given in Table 13, the associated Lookup Table is selected as output of the Logical block. Option ‘0 – Default Table’ selects associated Lookup Table in all conditions.

0	<i>Default Table (Table1)</i>
1	<i>Cnd1 And Cnd2 And Cnd3</i>

2	<i>Cnd1 Or Cnd2 Or Cnd3</i>
3	<i>(Cnd1 And Cnd2) Or Cnd3</i>
4	<i>(Cnd1 Or Cnd2) And Cnd3</i>

Table 13: Table X – Conditions Logical Operator Options

The three logical operations are evaluated in order and the first to satisfy gets selected, thus if Table1 logical operation is satisfied, the Lookup Table associated with Table1 gets selected regardless of two other logical operations. In addition, if none of the logical operations is satisfied the Lookup Table associated with Table1 gets selected.

1.9. Lookup Table Function Block

Lookup Tables are used to give output response up to 10 slopes per input. If more than 10 slopes are required, A Programmable Logic Block can be used to combine up to three tables to get 30 slopes as described in Section 1.8.

Lookup tables have two differing modes defined by “**X-Axis Type**” setpoint, given in Table 14. Option ‘0 – Data Response’ is the normal mode where block input signal is selected with the “**X-Axis Source**” and “**X-Axis Number**” setpoints and X values present directly input signal values. With option ‘1 – Time Response’ the input signal is time and X values present time in milliseconds. And selected input signal is used as digital enable.

0	<i>Data Response</i>
1	<i>Time Response</i>

Table 14: X-Axis Type Options

The slopes are defined with (x, y) points and associated point response. X value presents input signal value and Y value corresponding Lookup Table output value. “PointN – Response” setpoint defines type of the slope from preceding point to the point in question. Response options are given in Table 15. ‘Ramp To’ gives a linearized slope between points, whereas ‘Jump to’ gives a point to point response, where any input value between X_{N-1} and X_N will result Lookup Table output being Y_N . “Point0 – Response” is always ‘Jump To’ and cannot be edited. Choosing ‘Ignored’ response causes associated point and all the following points to be ignored.

0	<i>Ignore</i>
1	<i>Ramp To</i>
2	<i>Jump To</i>

Table 15: PointN – Response Options

The X values are limited by minimum and maximum range of the selected input source if the source is a Math Function Block. For the fore mentioned sources X-Axis data will be redefined when ranges are changed, therefore inputs should be adjusted before changing X-Axis values. For other sources Xmin and Xmax are -100000 and 1000000. The X-Axis is constraint to be in rising order, thus value of the next index is greater than or equal to preceding one. Therefore, when adjusting the X-Axis data, it is recommended that X_{10} is changed first, then lower indexes in descending order.

$X_{min} \leq X_0 \leq X_1 \leq X_2 \leq X_3 \leq X_4 \leq X_5 \leq X_6 \leq X_7 \leq X_8 \leq X_9 \leq X_{10} \leq X_{max}$
The Y-Axis has no constraints on the data it presents, thus inverse, decreasing, increasing or other response can be easily established. The Smallest of the Y-Axis values is used as Lookup Table output min and the largest of the Y-Axis values is used as Lookup Table output max (i.e. used as

Xmin and Xmax values in linear calculation.). Ignored points are not considered for min and max values.

1.10. Conditional Block

The Conditional Block compares up to four different input sources with different logical or relational operators. The result of each block can therefore only be true (1) or false (0). Figure 2 demonstrates the connections between all parameters.

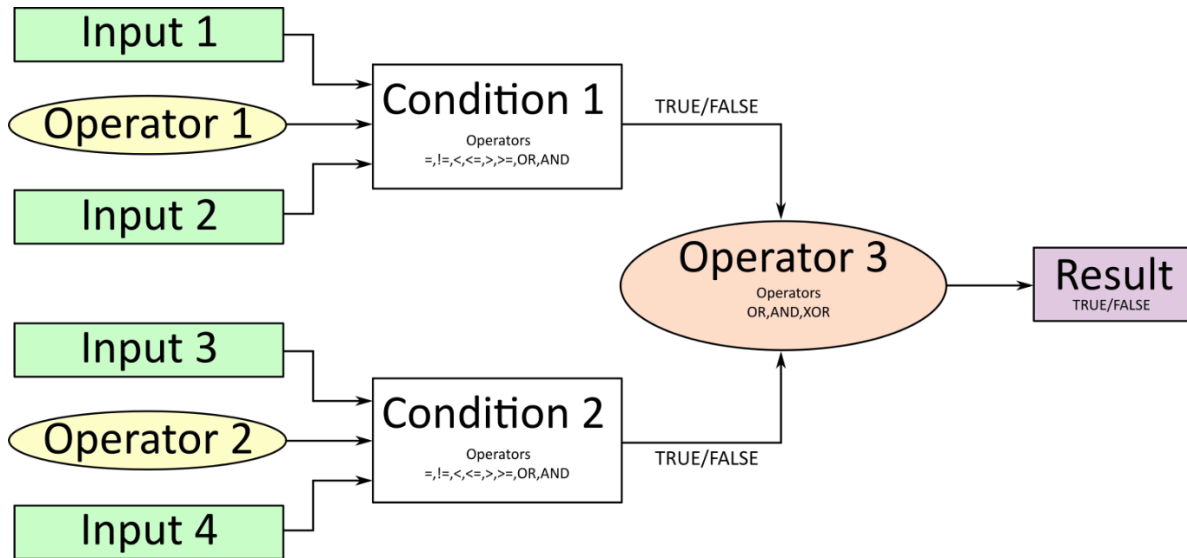

Figure 2: Conditional Block Diagram

Each Conditional Block offers two conditions. Both compare two inputs, which can hold a logical value or an integer value. The output of the conditions can only be true or false and will be compared by Operator 3 with a logical operator. This comparison is the result of the Conditional Block and can control any output source.

value of each source will then be compared to each other with an operator of Table 16. If no source is selected, the output value of an Input will be zero.

Value	Meaning
0	==, True when Argument 1 is equal to Argument 2
1	!=, True when Argument 1 is not equal to Argument 2
2	>, True when Argument 1 is greater than Argument 2
3	>=, True when Argument 1 is greater than Argument 2
4	<, True when Argument 1 is less than Argument 2
5	<=, True when Argument 1 is less than or equal Argument 2
6	OR, True when Argument 1 or Argument 2 is True
7	AND, True when Argument 1 and Argument 2 are True

Table 16: Input Operator Options

Operator 1 and Operator 2 are configured to OR by default. The table above cannot be used for comparing the conditions because they can only be compared with logical operators, which are listed in Table 17.

Value	Meaning
0	OR, True when Argument 1 or Argument 2 is True
1	AND, True when Argument 1 and Argument 2 are True
2	XOR, True when Argument 1 is not equal to Argument 2

Table 17: Condition Operator Options

If only one condition is used, it is to make sure that Operator 3 is set to **OR** so that the result is based solely on the condition which has been chosen.

1.11. Set / Reset Latch Function Block

Set-Reset Block consists of only 2 control sources: **Reset Source** and **Set Source**. The purpose of these blocks is to simulate a modified latching function in which the 'Reset Signal' has more precedence. The 'latching' function works as per the Table 18 below.

'Set Signal'	'Reset Signal'	'Set-Reset Block Output' (Initial State: OFF)
OFF	OFF	Latched State
OFF	ON	OFF
ON	OFF	ON
ON	ON	OFF

Table 18 – Set-Reset Function block operation

The **Reset** and **Set** sources have associated with them a minimum and maximum threshold values which determine the ON and OFF state. For the **Reset Source** are **Reset Minimum Threshold** and **Reset Maximum Threshold**. Similarly, for the **Set Source** are **Set Minimum Threshold** and **Set Maximum Threshold**. These setpoints also allow to have a dead band in between ON/OFF states and they are in terms of percentage of input selected.

As seen in Table 18 above, the 'Reset Signal' has more precedence over the 'Set Signal' - if the state of 'Reset Signal' is *ON*, the state of 'Set-Reset Block Output' will be *OFF*. To create an *ON* state in 'Set-Reset Block Output' the state of 'Reset Signal' must be *OFF* while the state of 'Set Signal' is *ON*. In this case, the state of 'Set-Reset Block Output' will remain *ON* even if 'Set Signal' turns *OFF* as long as 'Reset Signal' remains *OFF*. As soon as the 'Reset Signal' turns *ON* the 'Set-Reset Block Output' will turn *OFF* regardless of the state of 'Set Signal'.

1.12. CAN Transmit Function Block

The ECU provides up to 10 fully configurable CAN Transmit messages. Each block can have its own **PGN**. Different transmit messages that share a PGN will be broadcast together as one message.

The CAN transmit message is always enabled and the **Repetition Rate** defines which time in milliseconds the CAN transmit message is repeated. The CAN message will not transmit on the J1939 network in case all CAN transmits have the same PGN and the **Repetition Rate** of the first CAN transmit is set to zero. In the case of shared PGNs the rate of the lowest number CAN

Transmit is used, i.e. if CAN Transmit 1 and CAN Transmit 4 share a PGN, the Repetition Rate of CAN Transmit 1 is used.

The CAN Transmit messages can be sent on any Proprietary A or B PGN as broadcast messages. By default, the **Message Priority** is set to 6 (low priority).

The **Destination Address** of the J1939 Identifier can be changed to any value between 0...255.

The **Data Size**, **Data Index in Array (LSB)**, **Bit Index in Byte (LSB)**, **Resolution**, and **Offset** can all be used to map any SPN supported message by the J1939 standard from any **Data Source/Number** of the Transmit Function Block.

*Note: In this case, when the **Data Size** is set to 32 bits for all 4 control sources, each next value will erase the previous data in a CAN Transmit message at the place where they are overlapping.*

1.13. CAN Receive Function Block

The ECU supports up to 10 unique fully configurable CAN Receive Messages. The CAN Receive function block is designed to take any SPN from the J1939 network and use it as a **Control Source** for any relay outputs or CAN transmits.

The **Receive Message Enabled** is the most important setpoint associated with this function block and it should be selected first. Changing it will result in other setpoints being enabled/disabled as appropriate. By default, all receive messages are disabled.

Once a message has been enabled, a Lost Communication fault will be flagged if that message is not received within the **Receive Message Timeout** period if this has been set to 10ms or higher. This will trigger a Lost Communication event and the output data of the CAN Receive message will be set to 0. To avoid timeouts (if set to 10ms or higher) on a heavily saturated network, it is recommended to set the period at least three times longer than the expected update rate. To disable the timeout feature, simply set this value to zero, in which case the received message will never timeout and will never trigger a Lost Communication event.

By default, all control messages are expected to be sent to the ECU on Proprietary B PGNs. However, should a PDU1 message be selected, the ECU can be configured to receive it from any ECU by setting the **Specific Address that sends the PGN** to the Global Address (0xFF). If a specific address is selected instead, then any other ECU data on the PGN will be ignored.

The **Data Size**, **Data Index in Array (LSB)**, **Bit Index in Byte (LSB)**, **Resolution** and **Offset** can all be used to map any SPN supported by the J1939 standard to the output data of the Received function block.

The **Data Min** (Off Threshold) and **Data Max** (On Threshold) setpoints determine the minimum and maximum values of the control signal. As the names imply, they are also used as the ON/OFF thresholds for digital level types. These values are in whatever units the incoming data is **after** the resolution and offset are applied to the CAN Receive signal.

To have a CAN Receive message trigger, a relay output ON or OFF is to make sure the **Data Min (OFF Threshold)** and **Data Max (ON Threshold)** parameters are adjusted to the user's application. When the CAN Receive message (after having the resolution and offset applied to it), anything at **Data Max (ON Threshold)** parameter or higher, will trigger an ON command. Similarly,

anything at **Data Min (OFF Threshold)** parameter or lower will trigger an OFF command. Any data in between will not change the state, thus providing a hysteresis. Figure 3 illustrates this behaviour.

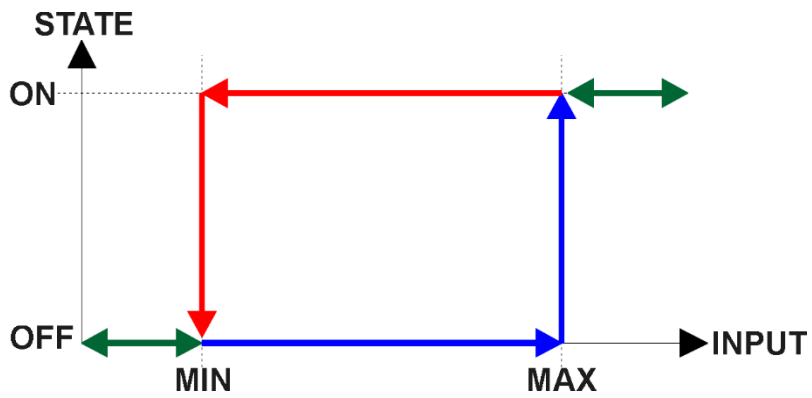

Figure 3: CAN Receive Message to Digital Output State

2. OVERVIEW OF J1939 FEATURES

The software was designed to provide flexibility to the user with respect to messages sent to and from the ECU by providing:

- Configurable ECU Instance in the NAME (to allow multiple ECUs on the same network)
- Configurable Transmit PGN and SPN Parameters
- Configurable Receive PGN and SPN Parameters
- Sending DM1 Diagnostic Message Parameters
- Reading and reacting to DM1 messages sent by other ECUs
- Diagnostic Log, maintained in non-volatile memory, for sending DM2 messages

2.1. Introduction To Supported Messages

The ECU is compliant with the standard SAE J1939, and supports the following PGNs

From J1939-21 - Data Link Layer

- | | |
|--|------------------|
| • Request | 59904 (\$00EA00) |
| • Acknowledgment | 59392 (\$00E800) |
| • Transport Protocol – Connection Management | 60416 (\$00EC00) |
| • Transport Protocol – Data Transfer Message | 60160 (\$00EB00) |
| • PropB Transmit, Default Digital I/O State Feedback | 65280 (\$00FF00) |
| • PropB Receive, Default Control Source Data Message | 65408 (\$00FF80) |
| • PropB Receive, Default Control Source Data Message | 65409 (\$00FF81) |
| • PropB Receive, Default Control Source Data Message | 65410 (\$00FF82) |
| • PropB Receive, Default Control Source Data Message | 65411 (\$00FF83) |
| • PropB Receive, Default Control Source Data Message | 65412 (\$00FF84) |
| • PropB Receive, Default Control Source Data Message | 65413 (\$00FF85) |
| • PropB Receive, Default Control Source Data Message | 65414 (\$00FF86) |
| • PropB Receive, Default Control Source Data Message | 65415 (\$00FF87) |

Note: Any Proprietary B PGN in the range 65280 to 65535 (\$00FF00 to \$00FFFF) can be selected

Note: The Proprietary A PGN 61184 (\$00EF00) can also be selected for any CAN Receive or CAN Transmit messages.

From J1939-73 - Diagnostics

- | | |
|--|------------------|
| • DM1 – Active Diagnostic Trouble Codes | 65226 (\$00FECA) |
| • DM2 – Previously Active Diagnostic Trouble Codes | 65227 (\$00FECB) |
| • DM3 – Diagnostic Data Clear/Reset for Previously Active DTCs | 65228 (\$00FECC) |
| • DM11 - Diagnostic Data Clear/Reset for Active DTCs | 65235 (\$00FED3) |
| • DM14 – Memory Access Request | 55552 (\$00D900) |
| • DM15 – Memory Access Response | 55296 (\$00D800) |
| • DM16 – Binary Data Transfer | 55040 (\$00D700) |

From J1939-81 - Network Management

- | | |
|--------------------------------|------------------|
| • Address Claimed/Cannot Claim | 60928 (\$00EE00) |
| • Commanded Address | 65240 (\$00FED8) |

From J1939-71 – Vehicle Application Layer

- | | |
|---------------------------|------------------|
| • Software Identification | 65242 (\$00FEDA) |
|---------------------------|------------------|

None of the application layer PGNs are supported as part of the default configurations, but they can be selected as desired for either transmit or received function blocks. Setpoints are accessed using standard Memory Access Protocol (MAP) with proprietary addresses. The Electronic Assistant (EA) allows for quick and easy configuration of the unit over the CAN network.

2.2. J1939 Name, Address and Software ID

The controller has a J1939 name which is broadcasted at power up and/or when its ECU Address has been changed. The Software ID PGN gives useful information regarding the controller.

2.2.1. J1939 Name

The ECU has the following defaults for the J1939 Name. The user should refer to the SAE J1939/81 standard for more information on these parameters and their ranges.

Arbitrary Address Capable	Yes
Industry Group	0, Global
Vehicle System Instance	0
Vehicle System	0, Non-specific system
Function	128, Axiomatic I/O Controller
Function Instance	31, AX030440 6UIN-8VREF-CAN
ECU Instance	0, First Instance
Manufacture Code	162, Axiomatic Technologies Corporation
Identity Number	Variable, uniquely assigned during factory programming for each ECU

The ECU Instance is a configurable setpoint associated with the NAME. Changing this value will allow multiple ECUs of this type to be distinguishable by other ECUs (including the Electronic Assistant) when they are all connected on the same network.

2.2.2. ECU Address

The default value of this setpoint is 128 (0x80), which is the preferred starting address for self-configurable ECUs as set by the SAE in J1939 tables B3 to B7. The EA will allow the selection of any address between 0 to 253, and ***it is the user's responsibility to select an address that complies with the standard.*** The user must also be aware that since the unit is arbitrary address capable, if another ECU with a higher priority NAME contends for the selected address, the controller will continue select the next highest address until it finds one that it can claim. See J1939/81 for more details about address claiming.

2.2.3. Software Identifier

PGN 65242	Software Identification	- SOFT
Transmission Repetition Rate:	On request	
Data Length:	Variable	
Extended Data Page:	0	
Data Page:	0	
PDU Format:	254	
PDU Specific:	218 PGN Supporting Information:	
Default Priority:	6	
Parameter Group Number:	65242 (0xFEDA)	
Start Position	Length	Parameter Name
1	1 Byte	Number of software identification fields
2-n	Variable	Software identification(s), Delimiter (ASCII “**”) 234
		SPN
		965
		234

For the ECU, Byte 1 is set to 1, and the identification fields are as follows

(Version)*

EA shows all this information in “General ECU Information”, as shown below

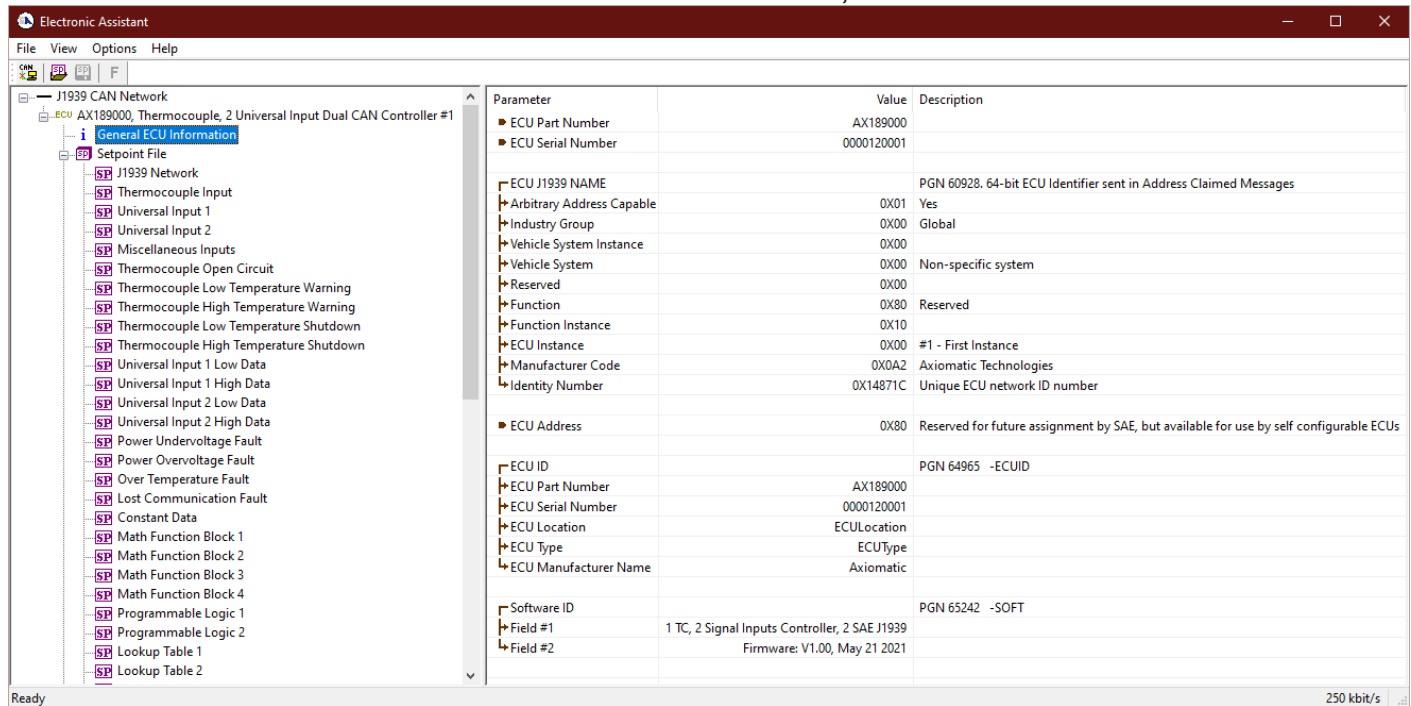

Note: The information provided in the Software ID is available for any J1939 service tool which supports the PGN -SOFT.

3. ECU SETPOINTS ACCESSED WITH ELECTRONIC ASSISTANT

Many setpoints have been reference throughout this manual. This section describes in detail each setpoint, their defaults and ranges. For more information on how each setpoint is used by the ECU, refer to the relevant section of the User Manual.

3.1. J1939 Network Setpoints

The J1939 Network setpoints deal with the setpoints such as *ECU Instance Number* and *ECU Address*. Figure 4 and Table 19 below will explain these setpoints and their ranges.

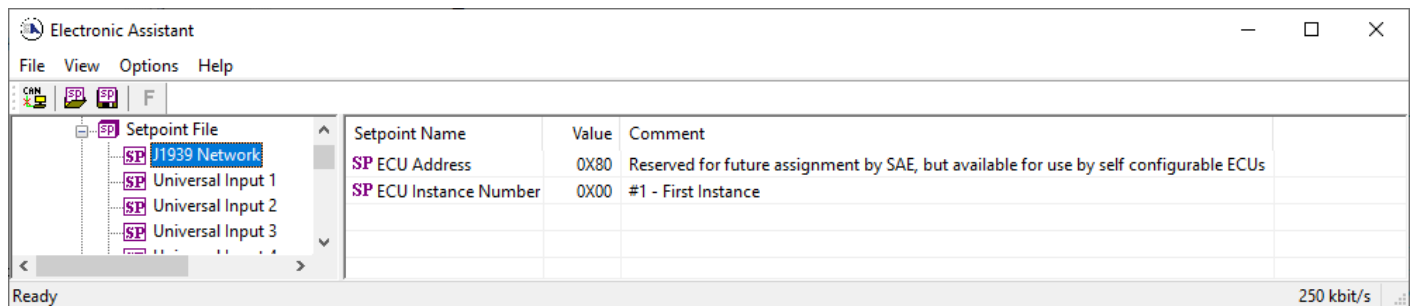

Figure 4: Screen Capture of Default J1939 Network Setpoints

Name	Range	Default	Notes
ECU Address	0 to 253	128 (0x80)	Preferred address for a self-configurable ECU
ECU Instance Number	Drop List	0, #1 – First Instance	Per J1939-81

Table 19: Default J1939 Network Setpoints

3.2. Universal Input Setpoints

The Universal Input setpoints are defined in Section 1.3. Refer to that section for detailed information on how these setpoints are used. The screen capture below in Figure 5 displays the available setpoints for each of the Universal Inputs. Table 20 below highlights the allowable ranges for each setpoint.

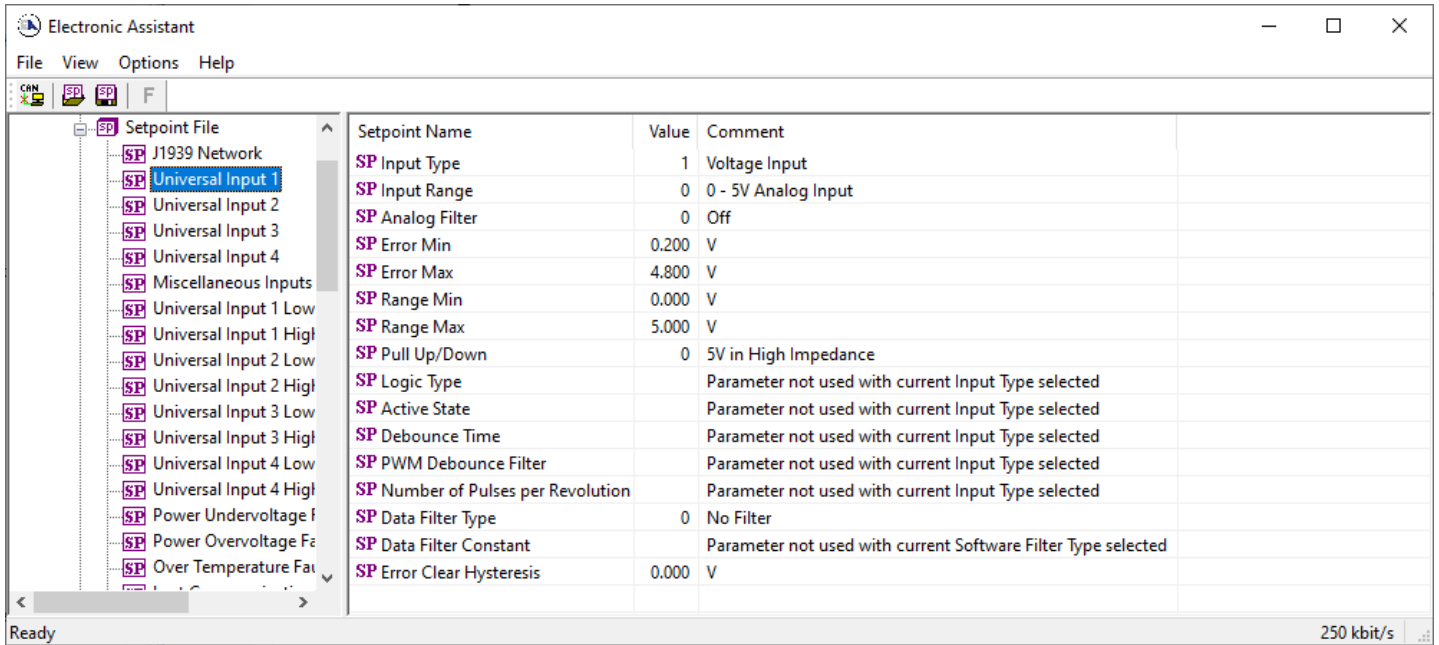

Figure 5: Screen Capture of Default Universal Input Setpoints

Name	Range	Default	Notes
Input Type	Drop List	Disabled	Refer to Section 1.3
Input Range	Drop List	0 (0-5V, or 0-20mA)	Refer to Section 1.3
Analog Filter	Drop List	Off	Refer to Section 1.3
Error Min	Depends on Input Type		Refer to Section 1.3
Error Max	Depends on Input Type		Refer to Section 1.3
Range Min	Depends on Input Type		Refer to Section 1.3
Range Max	Depends on Input Type		Refer to Section 1.3
Pull Up/Down	Drop List	No Pull	Refer to Section 1.3
Logic Type	Drop List	Input Not Implemented	Refer to Section 1.3
Active State	Drop List	Active High	Refer to Section 1.3
Debounce Time	0...65,000	10ms	Refer to Section 1.3
PWM Debounce Filter	Drop List	Off	Refer to Section 1.3
Number of Pulses per Revolution	0...1000	0	Refer to Section 1.3
Data Filter Type	Drop List	No Filter	Refer to Section 1.3
Data Filter Constant	1...1000	10	Refer to Section 1.3
Error Clear Hysteresis	Depends on Input Type	0	Refer to Section 1.3

Table 20: Default Universal Input Setpoints

3.3. Miscellaneous Setpoints

The Miscellaneous setpoints are defined in Section 1.4. Refer to that section for detailed information on how these setpoints are used. The screen capture below in Figure 6 displays the available setpoints. Table 21 highlights the allowable ranges for each setpoint.

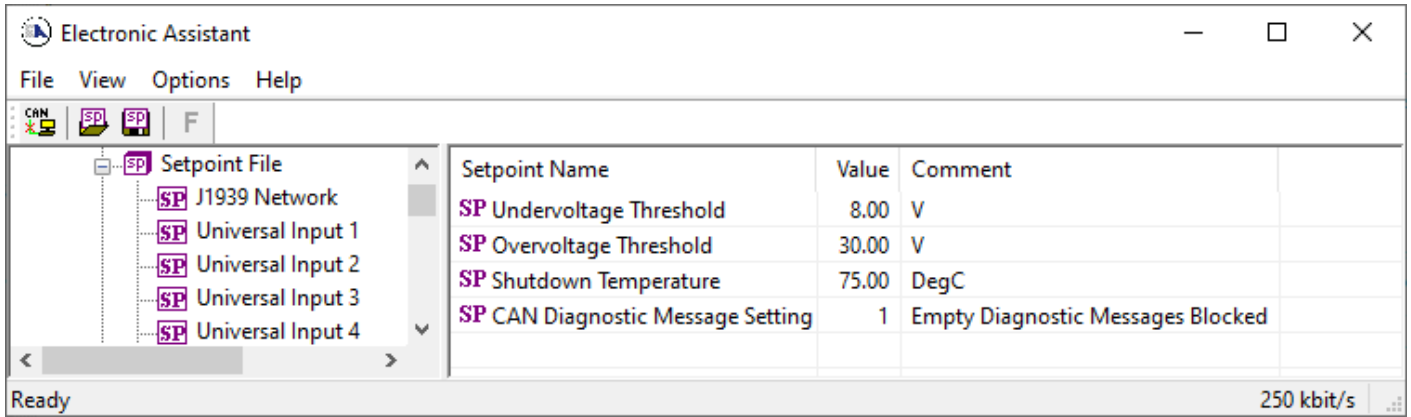

Figure 6: Screen Capture of Default Miscellaneous Setpoints

Name	Range	Default	Notes
Undervoltage Threshold	6.0...36.0	8.0	Units in [Volts]
Overvoltage Threshold	6.0...36.0	24.0	Units in [Volts]
Shutdown Temperature	40...125	85	Units in [Celsius]
Diagnostic Message Setting	Drop List	Diagnostics On	

Table 21: Default Miscellaneous Setpoints

3.4. Diagnostic Setpoints

The Diagnostic setpoints are defined in Section 1.5. Refer to that subsection for detailed information on how these setpoints are used. The screen capture below in Figure 7 displays the available setpoints for the Power Supply Diagnostic setpoints. Table 22 below highlights the allowable ranges for each setpoint.

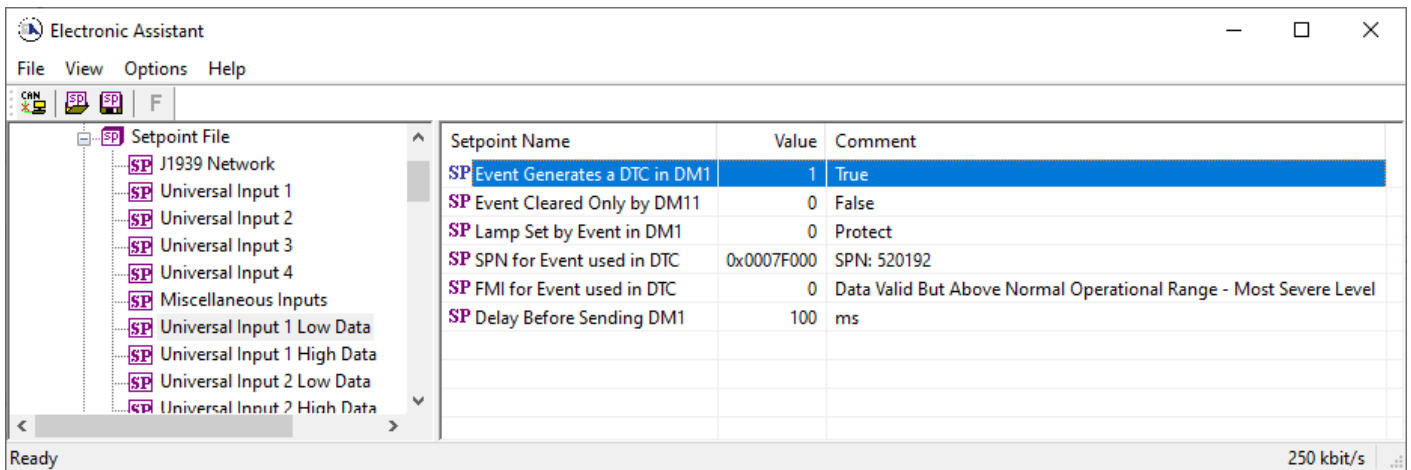

Figure 7: Screen Capture of Default Diagnostic Setpoints

Name	Range	Default	Notes
Event Generates a DTC in DM1	Drop List	False	Default changed to <i>True</i> for illustration purposes, Refer to Section 1.5
Event Cleared Only by DM11	Drop List	False	Refer to Section 1.5
Lamp Set by Event in DM1	Drop List	Amber, Warning	Refer to Section 1.5

SPN for Event used in DTC	0...524,287	520704	Refer to Section 1.5
FMI for Event used in DTC	Drop List	Voltage Below Normal, Or Shorted to Low Source	Refer to Table 10
Delay Before Sending DM1	0...84,600,000	1000	Units in [milliseconds]
Delay Before Clearing DM1	0...84,600,000	0	If digital output OFF after this time, a DTC will not be sent on a DM1 message anymore.

Table 22: Default Diagnostic Setpoints

3.5. Constant Data List Setpoints

The Constant Data List function block is provided to allow the user to select values as desired for various logic block functions. The four constants are fully user configurable to any value between +/- 1,000,000. The default values are displayed in the screen capture below.

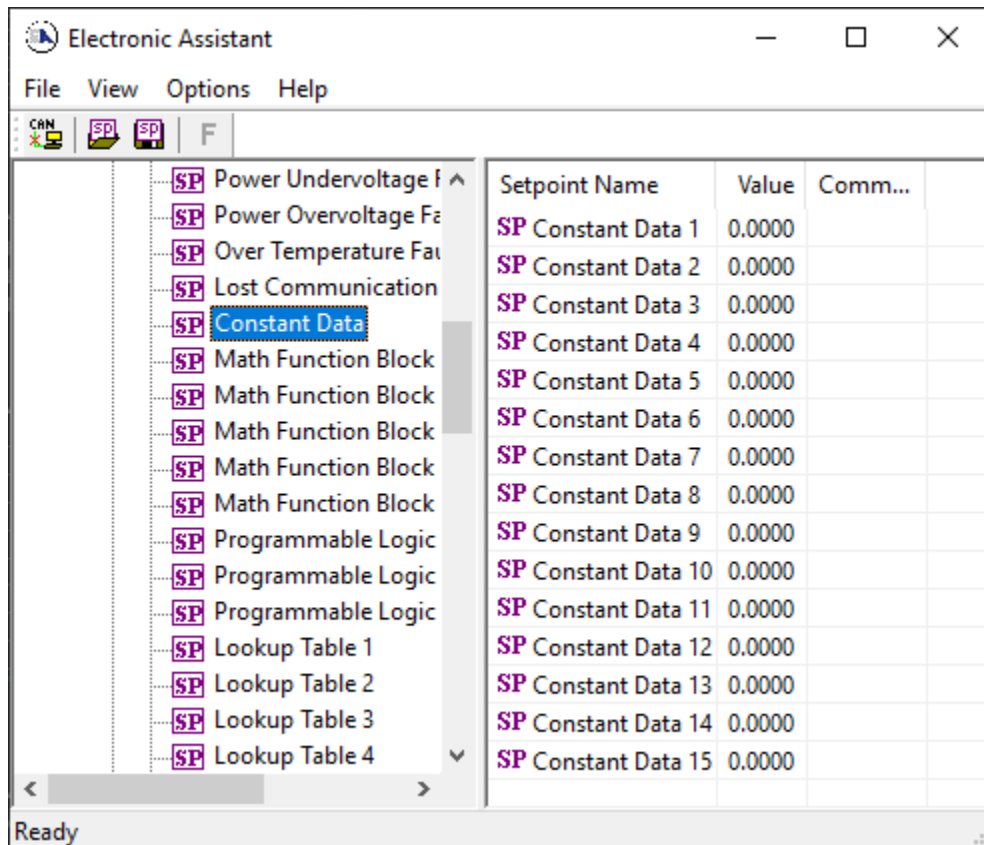

Figure 8: Screen Capture of Constant Data Setpoints

3.6. Math Functional Block Setpoints

The Math Functional Block setpoints are defined in Section 1.7. Refer to that section for detailed information on how these setpoints are used. The screen capture in Figure 9 displays the available setpoints for each of the Math Blocks. The table below the screen capture highlights the allowable ranges for each setpoint.

Note: Some setpoints were changed from their default values for informative purposes.

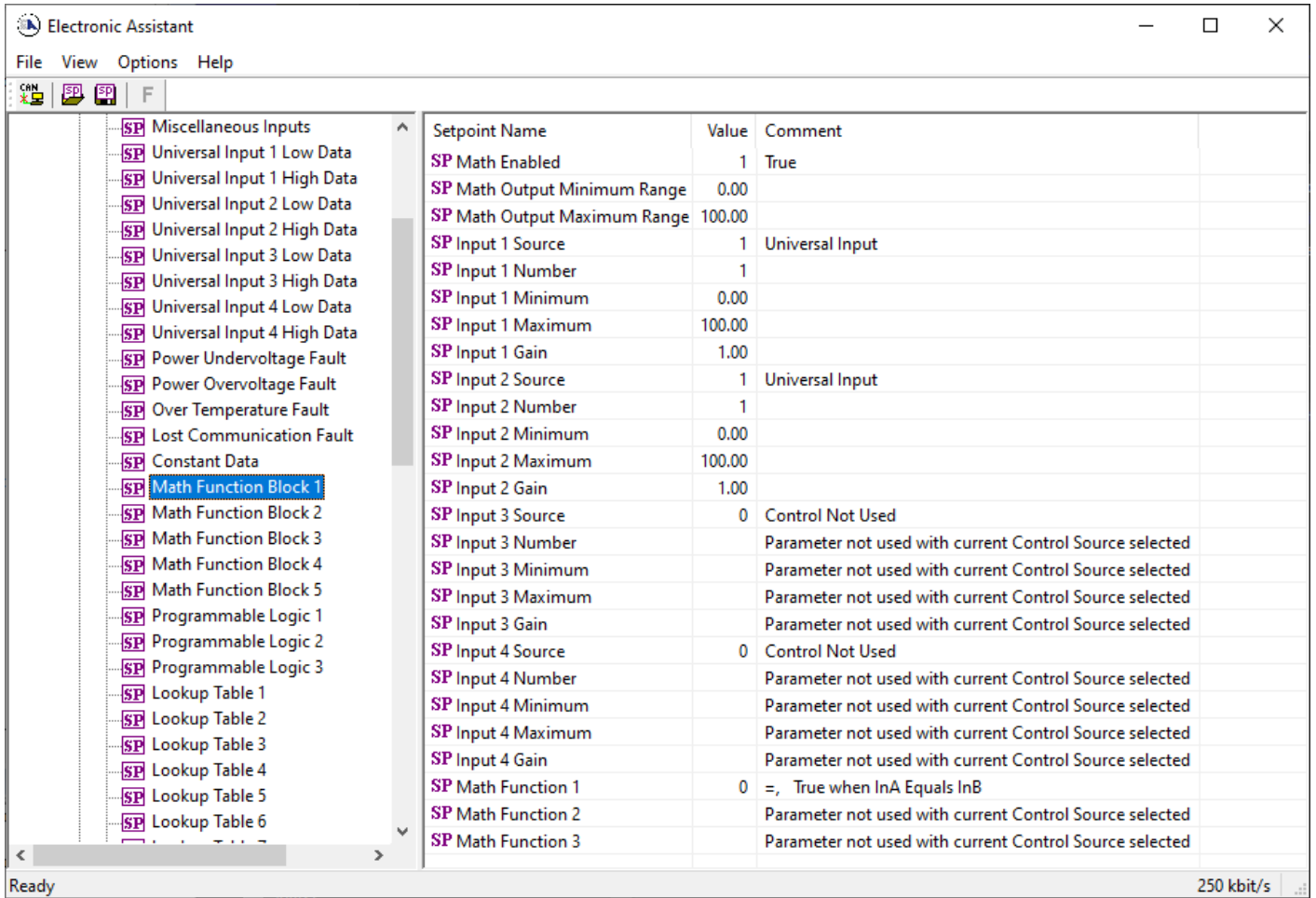

Figure 9: Screen Capture of Math Functional Block Setpoints

Name	Range	Default	Notes
Math Enabled	Drop List	False	
Math Output Minimum Range	-32768...32767	0	
Math Output Maximum Range	-32768...32767	100.0	
Input 1 Source	Drop List	Control not used	Refer to Table 1
Input 1 Number	Depends on control source	1	Refer to Table 1
Input 1 Minimum	-10 ⁶ ...10 ⁶	0.00	
Input 1 Maximum	-10 ⁶ ...10 ⁶	100.00	
Input 1 Gain	-100...100	1	
Input 2 Source	Drop List	Control not used	Refer to Table 1
Input 2 Number	Depends on control source	1	Refer to Table 1
Input 2 Minimum	-10 ⁶ ...10 ⁶	0.00	
Input 2 Maximum	-10 ⁶ ...10 ⁶	100.00	
Input 2 Gain	-100...100	1	
Input 3 Source	Drop List	Control not used	Refer to Table 1
Input 3 Number	Depends on control source	1	Refer to Table 1
Input 3 Minimum	-10 ⁶ ...10 ⁶	0.00	
Input 3 Maximum	-10 ⁶ ...10 ⁶	100.00	
Input 3 Gain	-100...100	1	
Input 4 Source	Drop List	Control not used	Refer to Table 1
Input 4 Number	Depends on control source	1	Refer to Table 1
Input 4 Minimum	-10 ⁶ ...10 ⁶	0.00	
Input 4 Maximum	-10 ⁶ ...10 ⁶	100.00	
Input 4 Gain	-100...100	1	

Math Function 1	Drop List	=, True When InA Equals InB	See Table 11
Math Function 2	Drop List	=, True When InA Equals InB	See Table 11
Math Function 3	Drop List	=, True When InA Equals InB	See Table 11

Table 23: Default Math Functional Block Setpoints

3.7. Programmable Logic Block Setpoints

The Programmable Logic Block setpoints are defined in Section 1.8. Refer to that section for detailed information on how these setpoints are used. The screen capture in Figure 10 displays the available setpoints for each of the Programmable Logic Blocks. The table below the screen capture highlights the allowable ranges for each setpoint.

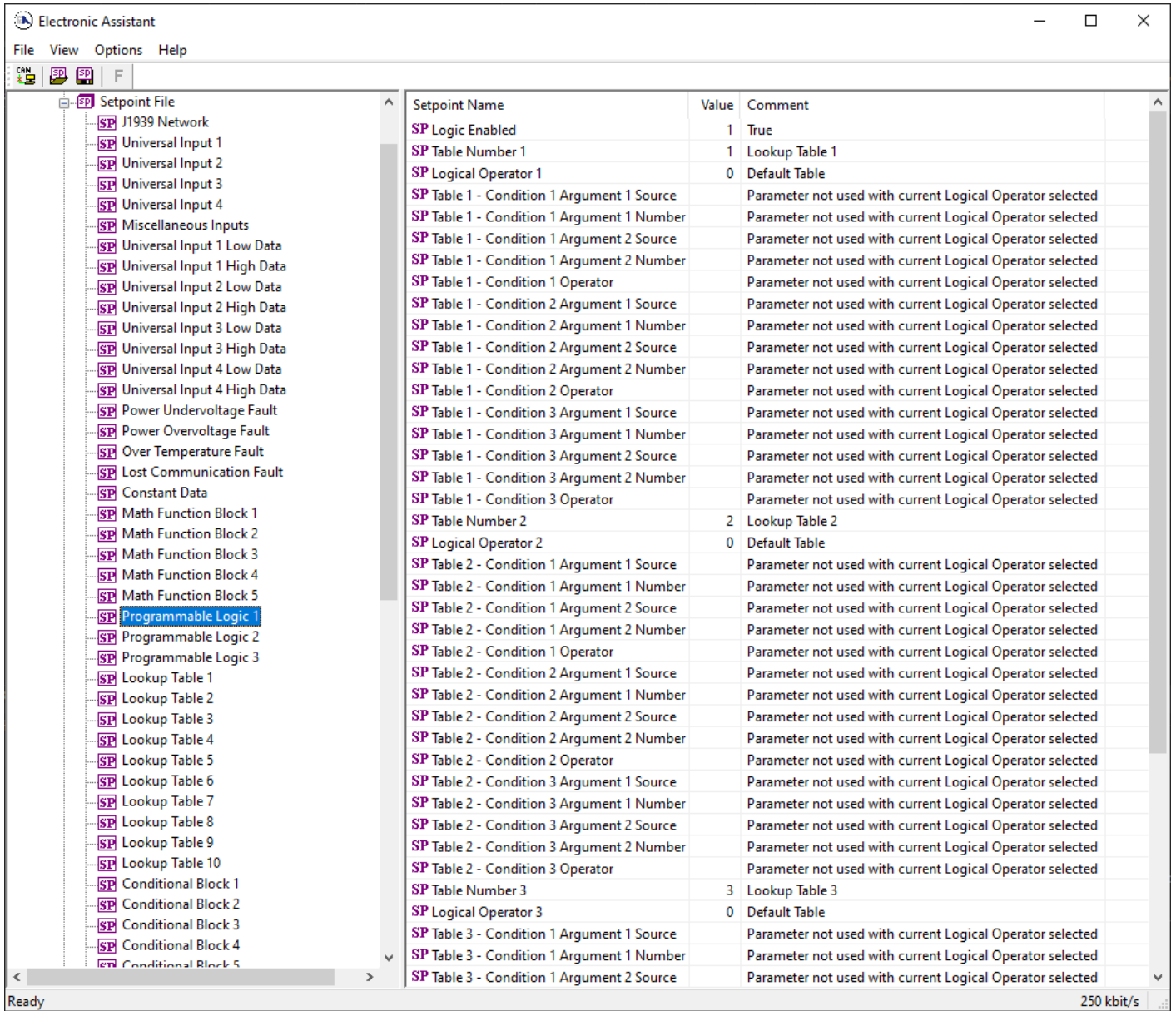

Figure 10: Screen Capture of Programmable Logic Block Setpoints

Name	Range	Default	Notes
Logic Enabled	Drop List	False	
Table Number 1	1 to 12	Lookup Table 1	
Logical Operator 1	Drop List	Default Table	See Table 13
Table 1 - Condition 1 Argument 1 Source	Drop List	Control Not Used	Refer to Table 1
Table 1 - Condition 1 Argument 1 Number	Depends on control source	1	Refer to Table 1
Table 1 - Condition 1 Argument 2 Source	Drop List	Control Not Used	Refer to Table 1
Table 1 - Condition 1 Argument 2 Number	Depends on control source	1	Refer to Table 1
Table 1 - Condition 1 Operator	Drop List	=, Equal	See Table 12
Table 1 - Condition 2 Argument 1 Source	Drop List	Control Not Used	Refer to Table 1
Table 1 - Condition 2 Argument 1 Number	Depends on control source	1	Refer to Table 1
Table 1 - Condition 2 Argument 2 Source	Drop List	Control Not Used	Refer to Table 1
Table 1 - Condition 2 Argument 2 Number	Depends on control source	1	Refer to Table 1
Table 1 - Condition 2 Operator	Drop List	=, Equal	See Table 12
Table 1 - Condition 3 Argument 1 Source	Drop List	Control Not Used	Refer to Table 1
Table 1 - Condition 3 Argument 1 Number	Depends on control source	1	Refer to Table 1

Table 1 - Condition 3 Argument 2 Source	Drop List	Control Not Used	Refer to Table 1
Table 1 - Condition 3 Argument 2 Number	Depends on control source	1	Refer to Table 1
Table 1 - Condition 3 Operator	Drop List	=, Equal	See Table 12

Table 24: Default Programmable Logic Block Setpoints

3.8. Lookup Table Setpoints

The Lookup Table Block setpoints are defined in Section 1.9. Refer to that section for detailed information on how these setpoints are used. The screen capture in Figure 11 displays the available setpoints for each of the Lookup Table Setpoints. The table below the screen capture highlights the allowable ranges for each setpoint.

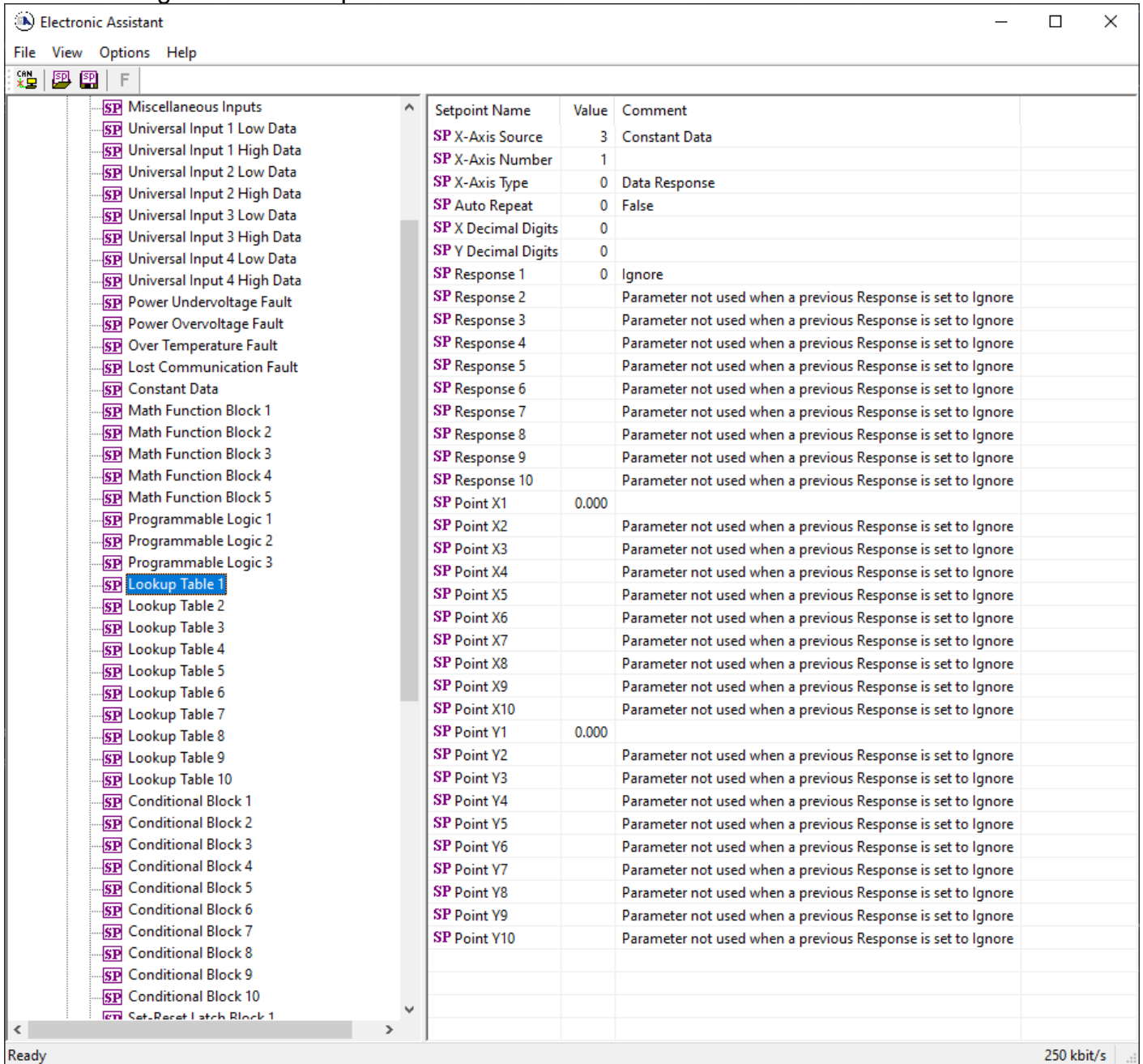

Figure 11: Screen Capture of Lookup Table Setpoints

Name	Range	Default	Notes
X-Axis Source	Drop List	Control Not Used	Refer to Table 1
X-Axis Number	Depends on control source	1	Refer to Table 1
X-Axis Type	Drop List	Data Response	See Table 14
Auto Repeat	Drop List	False	
X Decimal Digits	0...3	0	Resolution is 10^x , affects X points
Y Decimal Digits	0...3	0	Resolution is 10^x , affects Y points
Response 1	Drop List	Ramp To	See Table 15
Response 2	Drop List	Ramp To	See Table 15
Response 3	Drop List	Ramp To	See Table 15
Response 4	Drop List	Ramp To	See Table 15
Response 5	Drop List	Ramp To	See Table 15
Response 6	Drop List	Ramp To	See Table 15
Response 7	Drop List	Ramp To	See Table 15
Response 8	Drop List	Ramp To	See Table 15
Response 9	Drop List	Ramp To	See Table 15
Response 10	Drop List	Ramp To	See Table 15
Point X1	From X-Axis source minimum to Point 1 - X Value	X-Axis source minimum Depends on the Table number	See Section 1.9
Point X2	From Point 0 - X Value to Point 2 - X Value	Depends on the Table number	See Section 1.9
Point X3	From Point 1 - X Value to Point 3 - X Value	Depends on the Table number	See Section 1.9
Point X4	From Point 2 - X Value to Point 4 - X Value	Depends on the Table number	See Section 1.9
Point X5	From Point 3 - X Value to Point 5 - X Value source	Depends on the Table number	See Section 1.9
Point X6	From Point 4 - X Value to Point 6 - X Value	Depends on the Table number	See Section 1.9
Point X7	From Point 5 - X Value to Point 7 - X Value	Depends on the Table number	See Section 1.9
Point X8	From Point 6 - X Value to Point 8 - X Value	Depends on the Table number	See Section 1.9
Point X9	From Point 7 - X Value to Point 9 - X Value	Depends on the Table number	See Section 1.9
Point X10	From Point 8 - X Value to Point 10 - X Value	Depends on the Table number	See Section 1.9
Point Y1	-10^6 to 10^6	Depends on the Table number	
Point Y2	-10^6 to 10^6	Depends on the Table number	
Point Y3	-10^6 to 10^6	Depends on the Table number	
Point Y4	-10^6 to 10^6	Depends on the Table number	
Point Y5	-10^6 to 10^6	Depends on the Table number	
Point Y6	-10^6 to 10^6	Depends on the Table number	
Point Y7	-10^6 to 10^6	Depends on the Table number	
Point Y8	-10^6 to 10^6	Depends on the Table number	
Point Y9	-10^6 to 10^6	Depends on the Table number	
Point Y10	-10^6 to 10^6	Depends on the Table number	

Table 25: Default Lookup Table Setpoints

3.9. Conditional Block Setpoints

The Conditional Block setpoints are defined in Section 1.10. Refer to that section for detailed information on how these setpoints are used. The screen capture in Figure 12 displays the available setpoints for each of the Conditional Blocks. The table below the screen capture highlights the allowable ranges for each setpoint.

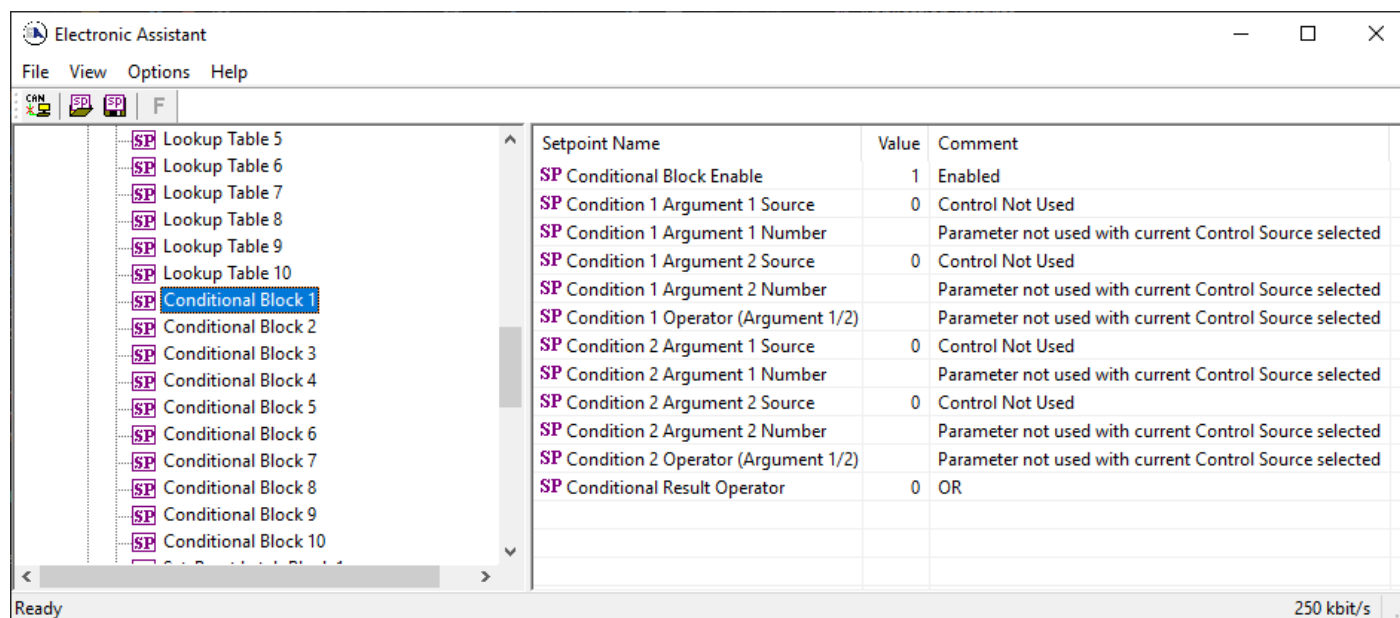

Figure 12: Screen Capture of Conditional Block Setpoints

Name	Range	Default	Notes
Conditional Function Enabled	Drop List	Disabled	
Condition 1 Argument 1 Source	Drop List	Digital Input	Refer to Table 1
Condition 1 Argument 1 Number	Depends on Source Selected	0	Refer to Table 1
Condition 1 Argument 2 Source	Drop List	Digital Input	Refer to Table 1
Condition 1 Argument 2 Number	Depends on Source Selected	0	Refer to Table 1
Condition 1 Operator (Argument 1/2)	Drop List	0	Refer to Table 16
Condition 2 Argument 1 Source	Drop List	Digital Input	Refer to Table 1
Condition 2 Argument 1 Number	Depends on Source Selected	0	Refer to Table 1
Condition 2 Argument 2 Source	Drop List	Digital Input	Refer to Table 1
Condition 2 Argument 2 Number	Depends on Source Selected	0	Refer to Table 1
Condition 2 Operator (Argument 1/2)	Drop List	0	Refer to Table 16
Conditional Result Operator	Drop List	OR	Refer to Table 17

Table 26: Default Conditional Block Setpoints

3.10. Set-Reset Latch Block

The Set-Reset Latch Block setpoints are defined in Section 1.11. Refer to that section for detailed information on how these setpoints are used. The screen capture in Figure 13 displays the available setpoints for each of the Set-Reset Latch Blocks. The table below the screen capture highlights the allowable ranges for each setpoint.

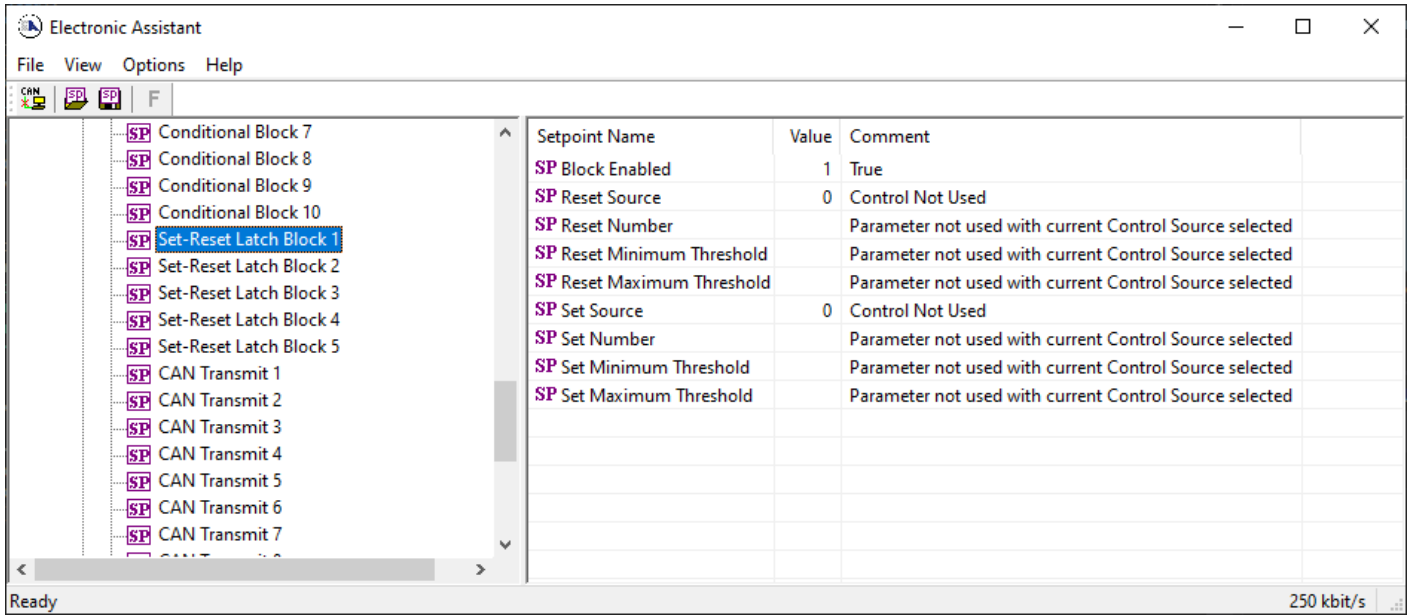

Figure 13: Screen Capture of Set-Reset Latch Block Setpoints

Name	Range	Default	Notes
Block Enabled	Drop List	False	
Reset Source	Drop List	Control Not Used	Refer to Table 1
Reset Number	Depends on Source Selected	1	Refer to Table 1
Reset Minimum Threshold	Drop List	0%	Refer to Section 1.11
Reset Maximum Threshold	Depends on Source Selected	100%	Refer to Section 1.11
Set Source	Drop List	Control Not Used	Refer to Table 1
Set Number	Drop List	1	Refer to Table 1
Set Minimum Threshold	Depends on Source Selected	0%	Refer to Section 1.11
Set Maximum Threshold	Drop List	100%	Refer to Section 1.11

Table 27: Default Set-Reset Latch Block Setpoints

3.11. CAN Transmit Setpoints

The CAN Transmit setpoints are defined in Section 1.12. Refer to that section for detailed information on how these setpoints are used. The screen capture below in Figure 14 displays the available setpoints for the CAN Transmit setpoints. Table 28 below highlights the allowable ranges for the first CAN Transmit setpoint.

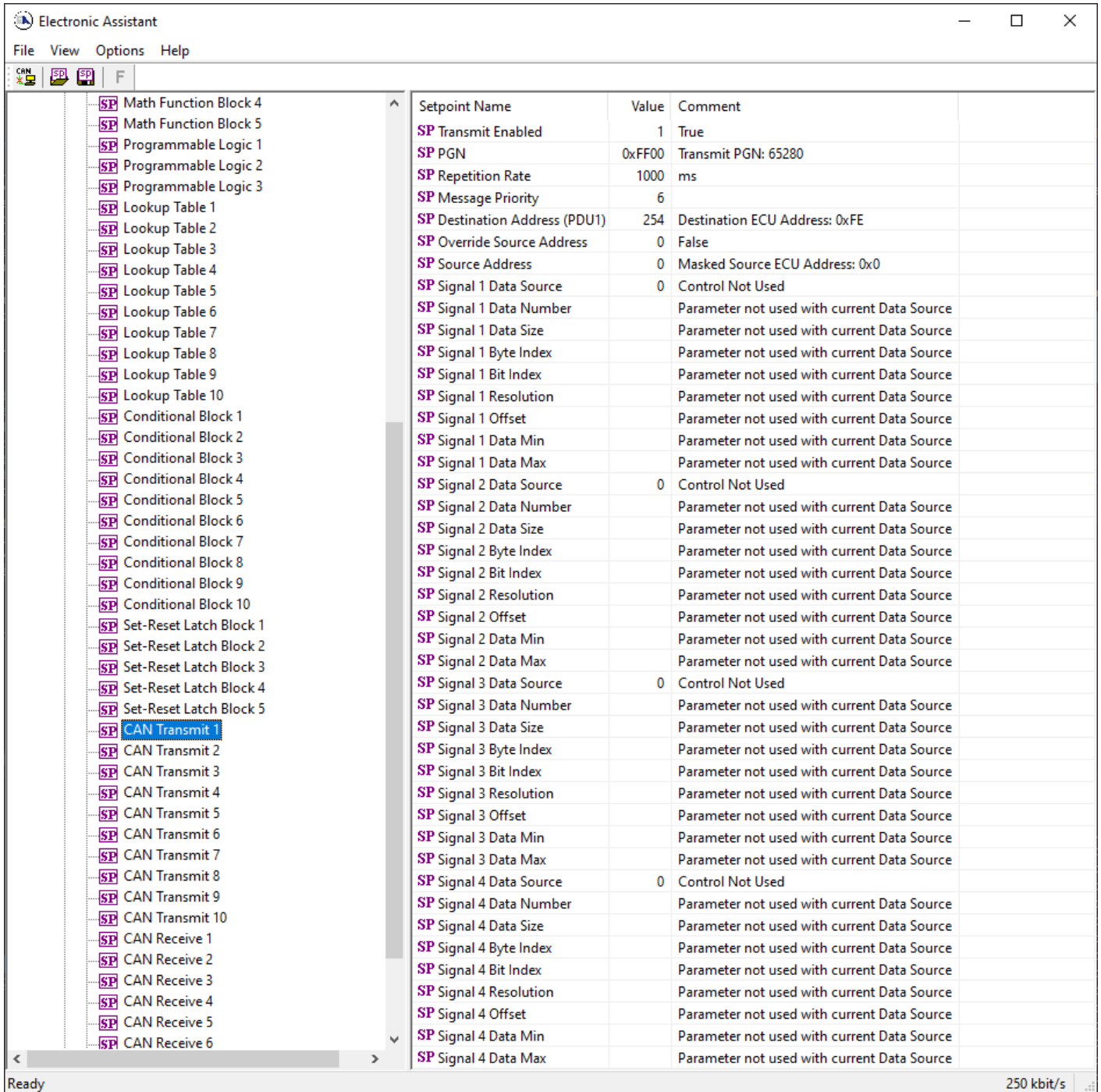

Figure 14: Screen Capture of Default CAN Transmit Setpoints

Name	Range	Default	Notes
PGN	0...65,535	65,280	Refer to Section 1.12
Repetition Rate	0...60,000	1000	Refer to Section 1.12
Message Priority	0...7	6	Refer to Section 1.12
Destination Address (PDU1)	0...255	254	Refer to Section 1.12
Data Source	Drop List	CAN Status Report	Refer to Table 1 Error! Reference source not found.
Data Number	Depends on Source Selected	1	Refer to Table 1
Data Size	0...32	0 bits	Refer to Section 1.12
Pos Byte	Depends on Source Selected	0	Refer to Section 1.12

Pos Bit	Depends on Source Selected	65,280	Refer to Section 1.12
Resolution	-100,000...100,000	1	Refer to Section 1.12
Offset	-100,000...100,000	0	Refer to Section 1.12

Table 28: Default CAN Transmit Setpoints

3.12. CAN Receive Setpoints

The CAN Receive setpoints are defined in Section 1.13. Refer to that section for detailed information on how these setpoints are used. The screen capture below in Figure 15 displays the available setpoints for the CAN Receive setpoints. Table 29 below highlights the allowable ranges for each setpoint.

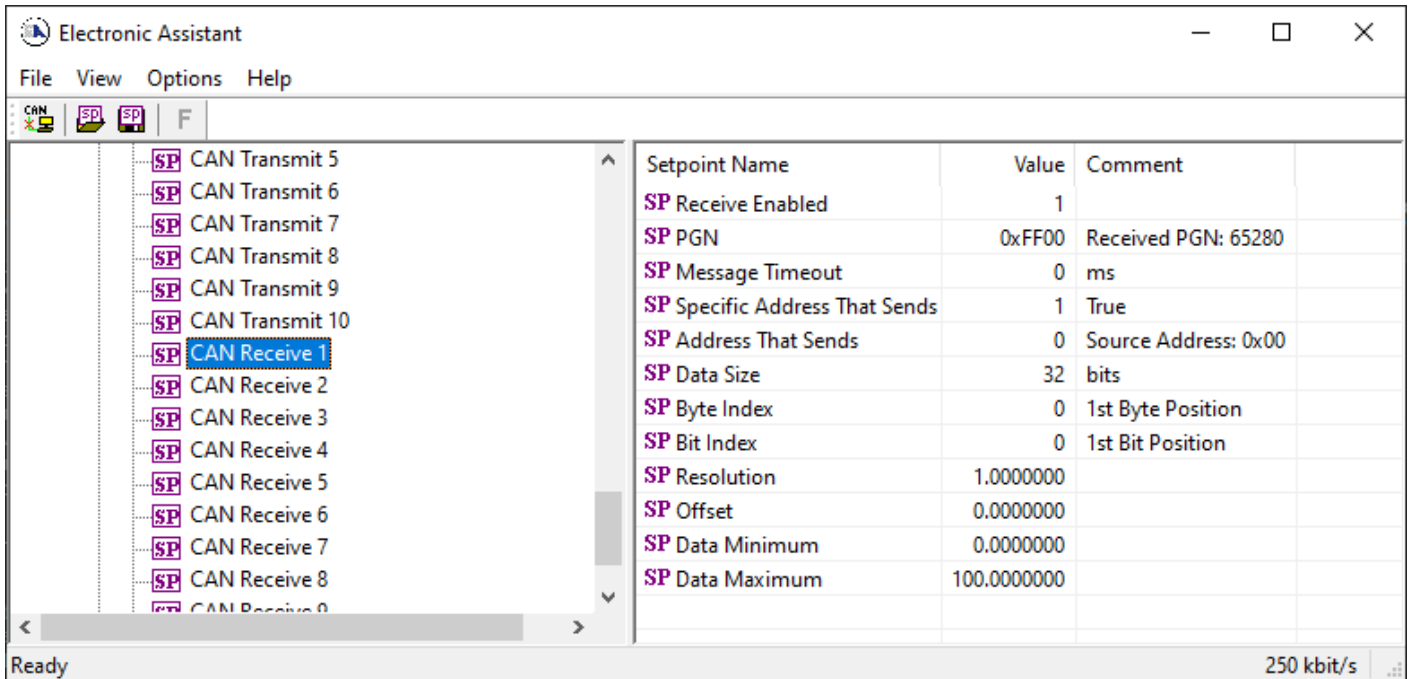

Figure 15: Screen Capture of Default CAN Receive Setpoints

Name	Range	Default	Notes
Message Enabled	Drop List	False	Default changed to <i>True</i> for illustration purposes. Refer to Section 1.13
PGN	0...65,535	65280	Refer to Section 1.13
Message Timeout	0...60,000	3000	Refer to Section 1.13
Data Size	0...32	0 bits	Refer to Section 1.13
Pos Byte	0...7	0	Refer to Section 1.13
Pos Bit	0...7	0	Refer to Section 1.13
Resolution	-0xFFFFFFFF...0xFFFFFFFF	1.0	Refer to Section 1.13
Offset	-0xFFFFFFFF...0xFFFFFFFF	0.0	Refer to Section 1.13
Data Minimum	-0xFFFFFFFF...Data Max	0.0	Refer to Section 1.13
Data Maximum	Data Min...0xFFFFFFFF	1.0	Refer to Section 1.13

Table 29: Default CAN Receive Setpoints

3.13. 5V to 8V Reference Switch

The 5V to 8V Reference Switch setpoint allows configuring the voltage reference output. Figure 16 and Table 30 below will explain these setpoints and their ranges.

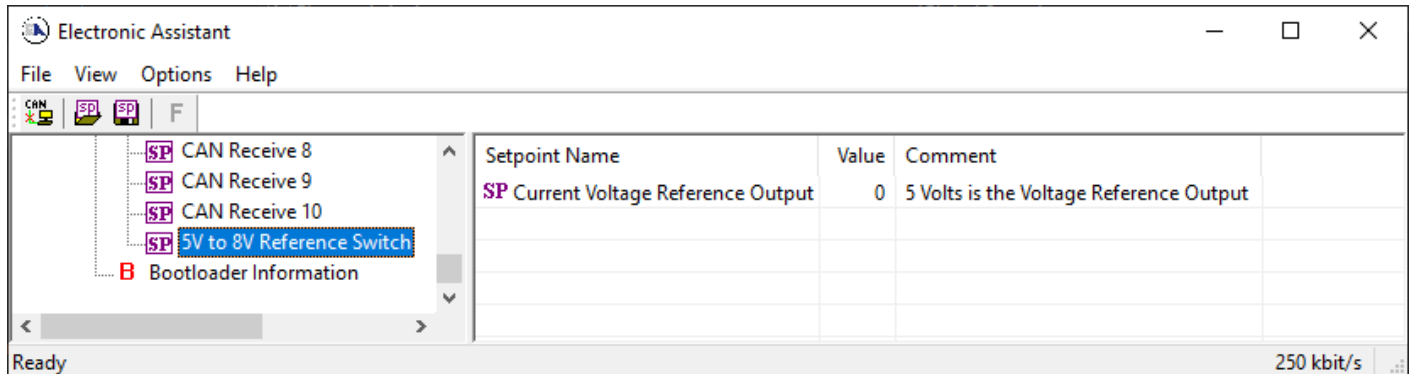

Figure 16: Screen Capture of Default 5V to 8V Reference Setpoint

Name	Range	Default	Notes
Current Voltage Reference Output	Drop List	0, 5V Reference	Can be either 0, 5V or 1, 8V reference

Table 30: Default 5V to 8V Reference Switch Setpoint

4. Reflashing over CAN with Electronic Assistant Bootloader

This chapter describes a procedure of re-programming an application firmware in CANJ1939 in the field.

4.1. Prerequisites

- A personal computer with a USB port running Windows operating system.
- A flash file for 6UIN-8VREF-CAN. It should have the following name: AF-21010-x.xx.bin, where x.xx – firmware version number, and sss are file comments information purposes.
- Axiomatic Electronic Assistant (EA) software, p/n AX070500.
- Axiomatic CAN Assistant – Scope software, p/n AX070501SCO.
- Axiomatic USB-CAN Converter, p/n AX070501. It should be connected to the USB port of the personal computer.
- Power supply to power the controllers.
- Wire harness to connect the controllers to the power supply and to the CAN port of the Axiomatic USB-CAN converter with proper termination resistance.

4.2. Re-flashing Procedure

1. Connect the ECU to the power supply and Axiomatic USB-CAN converter.
2. Open CAN port and start monitoring the CAN bus in CAN Assistant – Scope.
3. Power-up the controller.
4. Run the Electronic Assistant (EA) software and connect to the CAN port. The user should see the following screen:

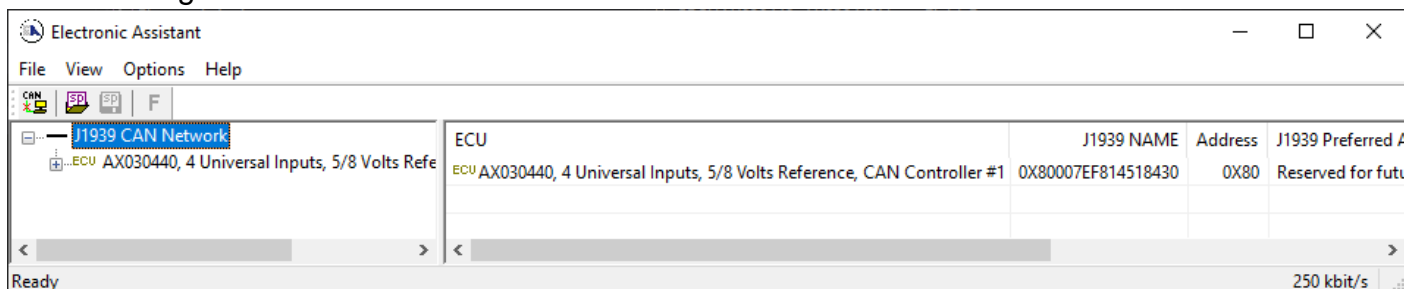

5. Click on *Bootloader Information* group in the left panel and then double click on *Force Bootloader to Load on Reset* and another window pops up. Select *OK* to switch to Bootloader Mode.

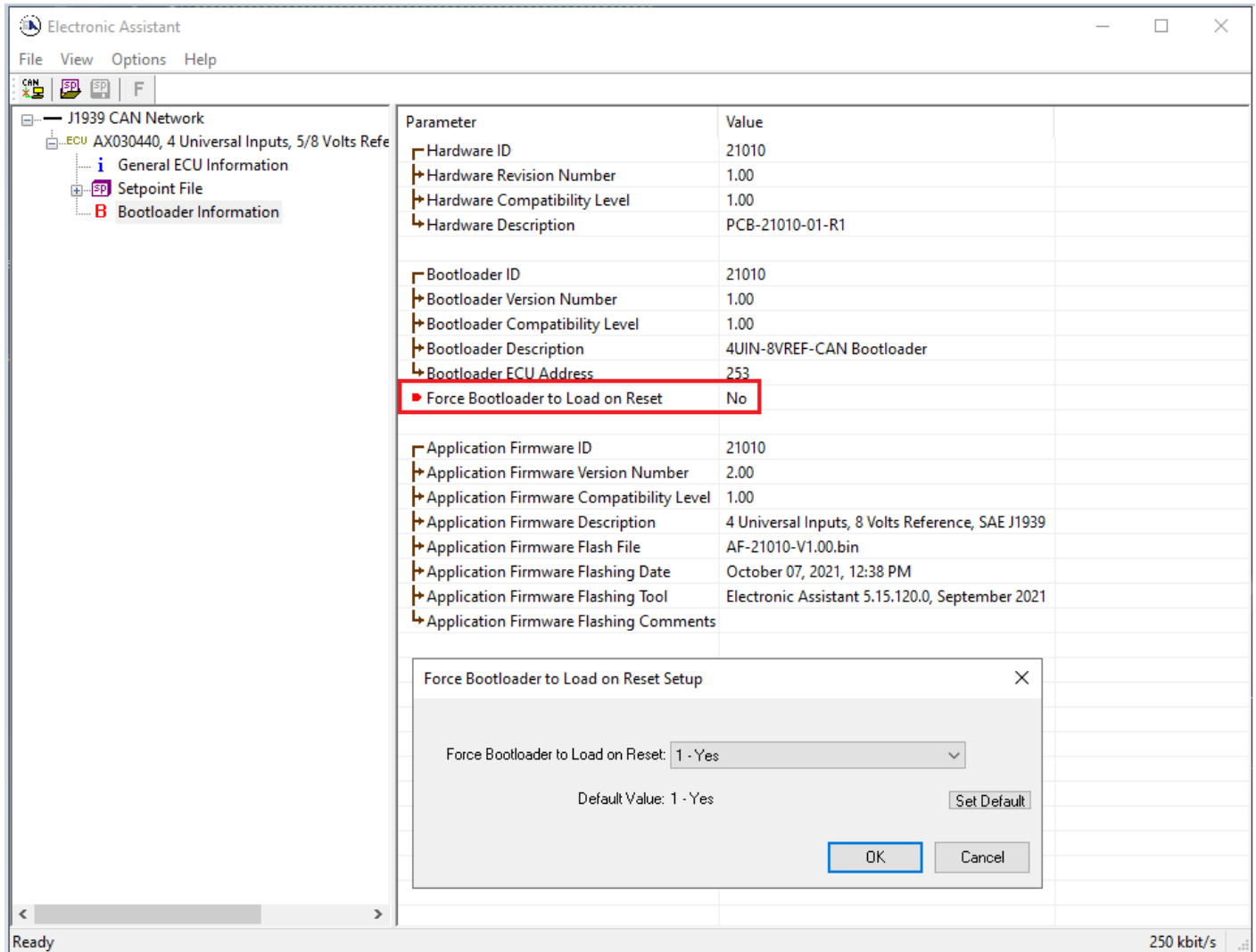

6. Cycle the power on to run the unit in Bootloader Mode. If you disconnect and reconnect the CAN connection in EA, you will only see the Bootloader ECU.

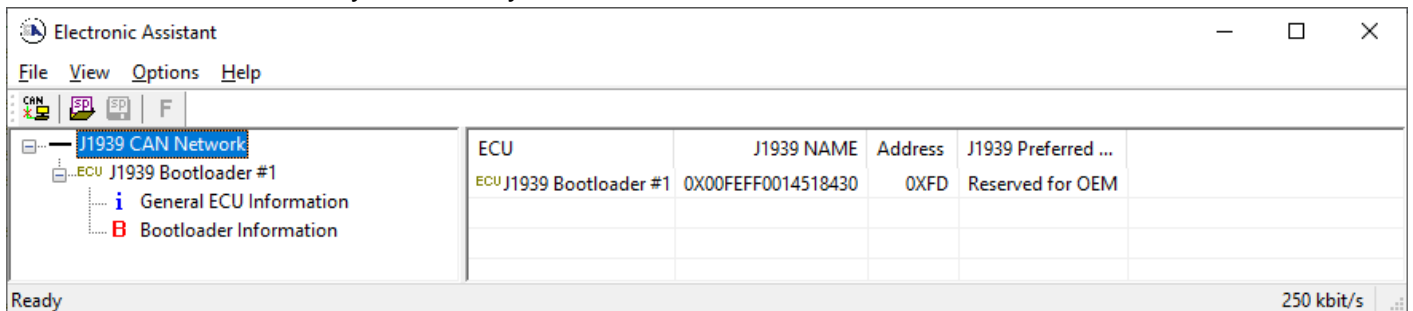

7. Click on the *Bootloader Information* group again and then on the **F** button in the EA toolbar. Select the flash file:

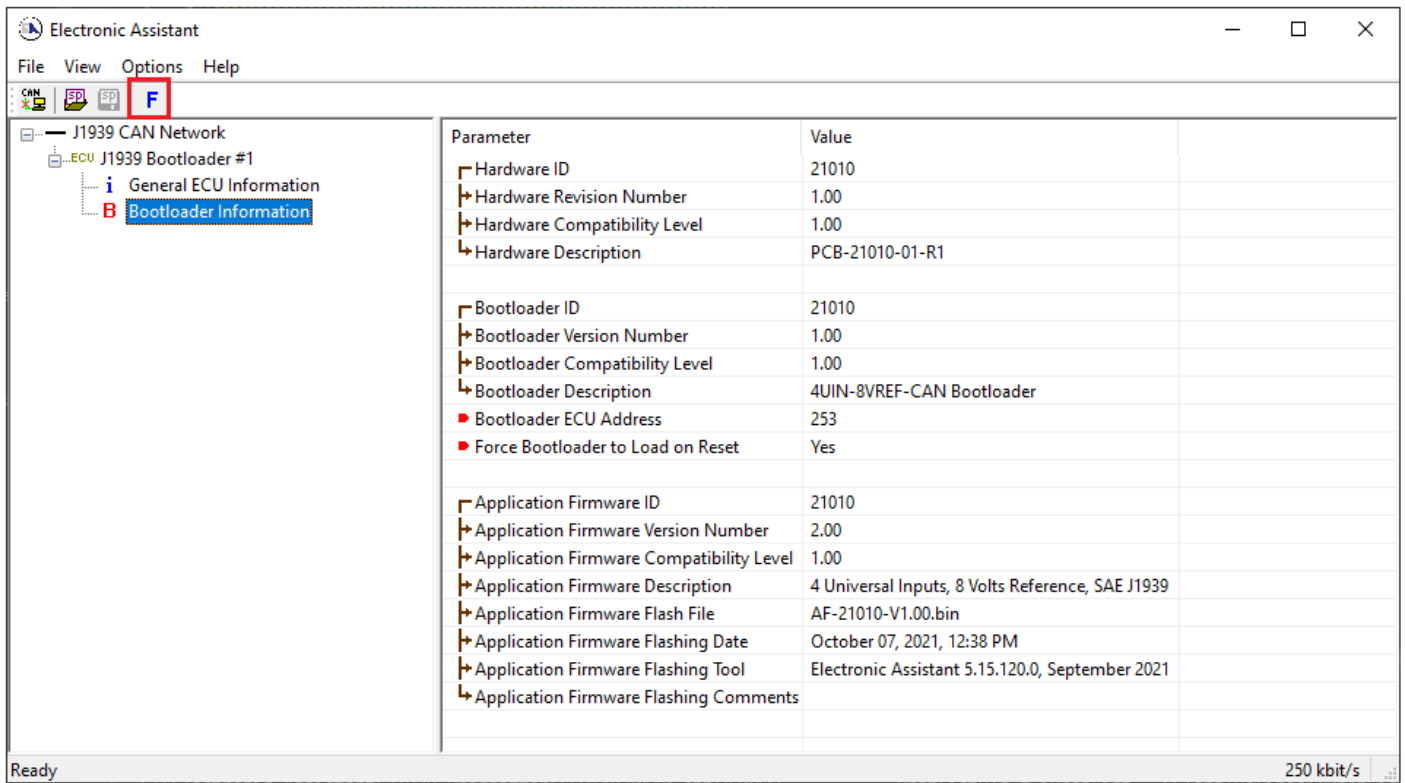

- Open the flash file and start flashing operation by pressing the *Flash ECU* button. **Make sure Erase All ECU Flash Memory is checked.**

Optionally, the user can write their comments in the *Flashing Comments* field.

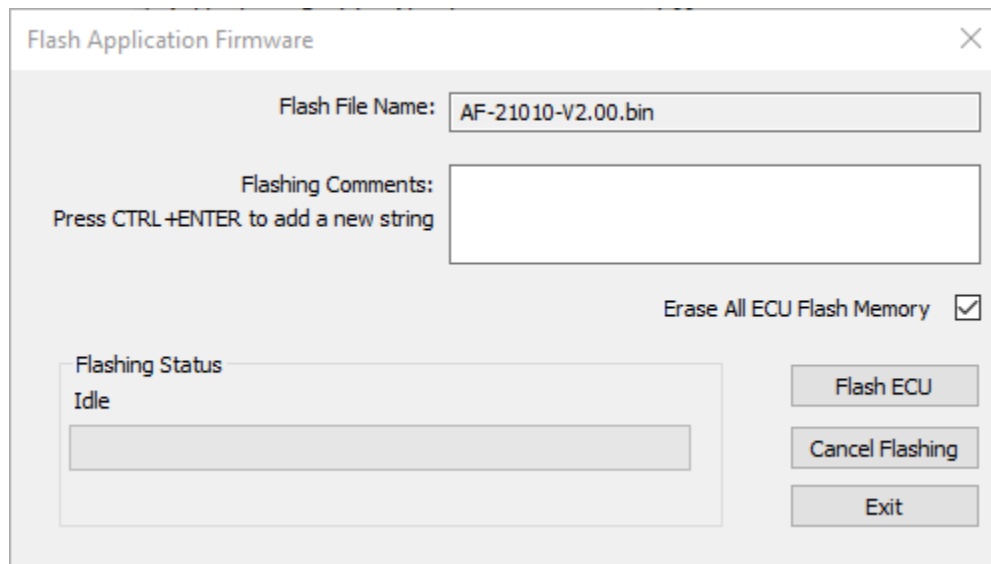

- Confirm the warning message from EA.

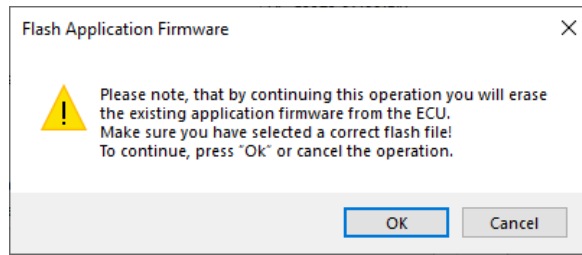

After confirming flashing, the user will see the flashing operation in dynamics on the EA screen.

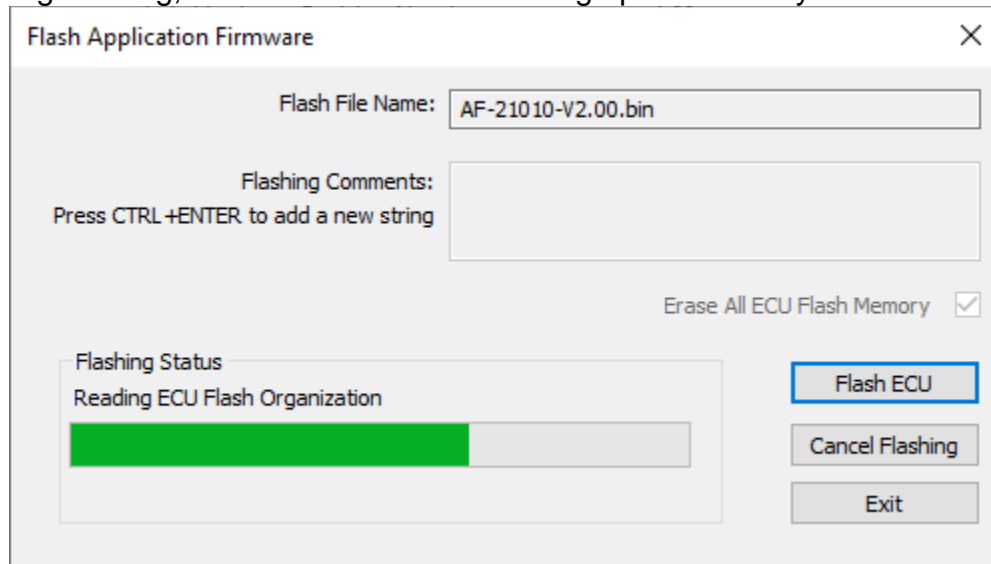

10. When flashing is done, reset the ECU and disconnect and reconnect the CAN connection.

The new firmware version should now be running on the unit, which can be reviewed by selecting Bootloader Information. The user can check the field *Application Firmware Flash File* to make sure that the uploaded firmware version is running on the unit.

Electronic Assistant

File View Options Help

CAN SP SP F

J1939 CAN Network

- ECU AX030440, 4 Universal Inputs, 5/8 Volts Refe
 - General ECU Information
 - Setpoint File
 - Bootloader Information**

Parameter	Value
Hardware ID	21010
Hardware Revision Number	1.00
Hardware Compatibility Level	1.00
Hardware Description	PCB-21010-01-R1
Bootloader ID	21010
Bootloader Version Number	1.00
Bootloader Compatibility Level	1.00
Bootloader Description	4UIN-8VREF-CAN Bootloader
Bootloader ECU Address	253
Force Bootloader to Load on Reset	No
Application Firmware ID	21010
Application Firmware Version Number	2.00
Application Firmware Compatibility Level	1.00
Application Firmware Description	4 Universal Inputs, 5/8 Volts Reference, SAE J1939
Application Firmware Flash File	AF-21010-V2.00.bin
Application Firmware Flashing Date	October 07, 2021, 02:56 PM
Application Firmware Flashing Tool	Electronic Assistant 5.15.121.0, October 2021
Application Firmware Flashing Comments	

Ready 250 kbit/s

5. INSTALLATION INSTRUCTIONS

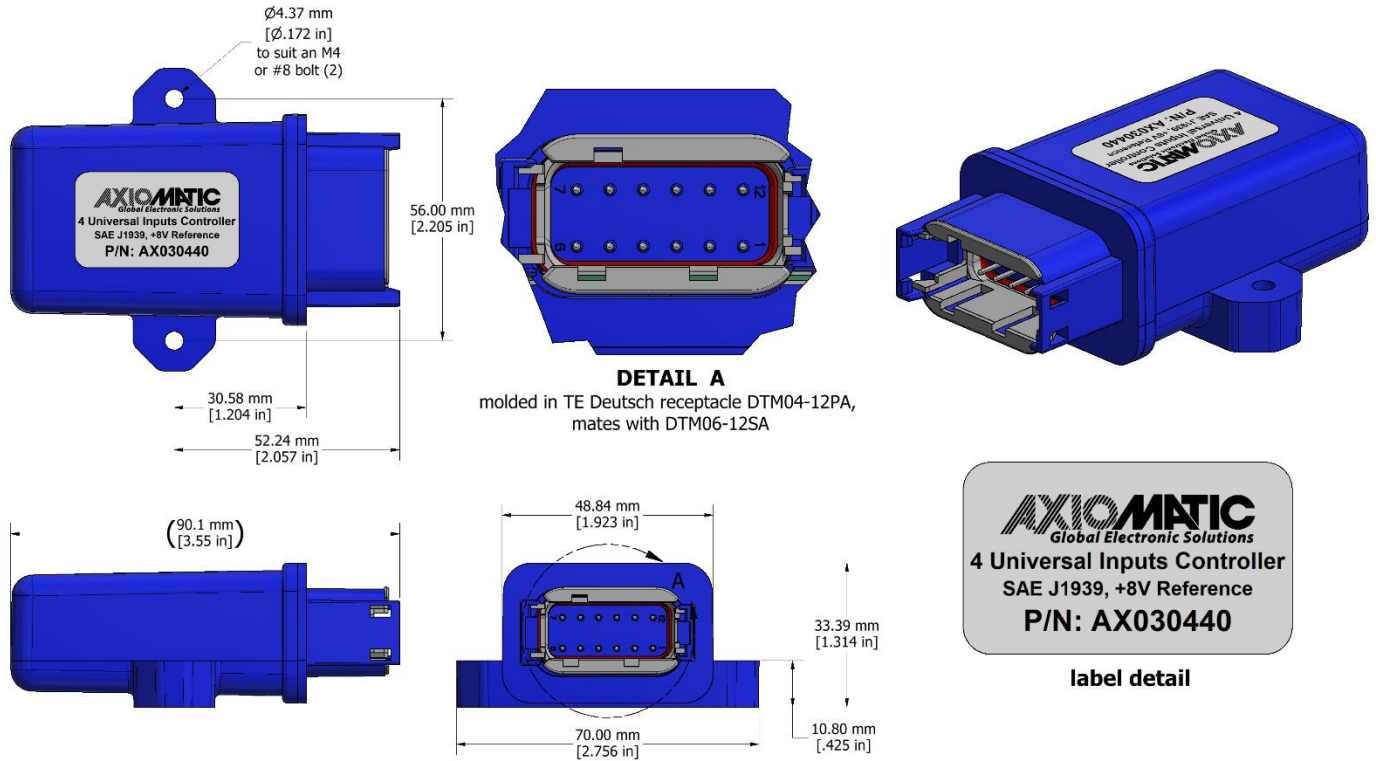

Integral TE Deutsch 12 pin receptacle (P/N: DTM04-12PA)

PIN #	FUNCTION
1	BATT -
2	+8V Reference
3	Input Ground
4	Input Ground
5	Input Ground
6	Universal Signal Input 1
7	Universal Signal Input 2
8	Universal Signal Input 4
9	Universal Signal Input 3
10	CAN_H
11	CAN_L
12	BATT +

6. TECHNICAL SPECIFICATIONS

Specifications are indicative and subject to change. Actual performance will vary depending on the application and operating conditions. Users should satisfy themselves that the product is suitable for use in the intended application. All our products carry a limited warranty against defects in material and workmanship. Please refer to our Warranty, Application Approvals/Limitations and Return Materials Process as described on www.axiomatic.com/service.html.

Power Supply

Power Supply Input	12 Vdc or 24 Vdc nominal 8...36 Vdc power supply range
Protection	Reverse polarity protection up to -100V. Undervoltage shutdown at 5Vdc. Overvoltage protection is up to 59 V.
Voltage Reference	User selectable +5V/+8V, 100 mA, 2% reference voltage output

Inputs

Inputs	4 Universal Signal Inputs Refer to Table 1.0.																								
Input Grounds	Three (3) are provided.																								
Protection	All inputs are protected against short to GND. All inputs are protected against shorts to Nominal Vps (36Vdc).																								
Input Accuracy and Resolution	<table border="1"> <thead> <tr> <th>Input Type</th> <th>Input Range</th> <th>Accuracy</th> <th>Resolution</th> </tr> </thead> <tbody> <tr> <td>Voltage</td> <td>0-5V, 0-10V</td> <td>+/-0.2%</td> <td>1 mV</td> </tr> <tr> <td>Current</td> <td>0(4)-20mA</td> <td>+/-0.2%</td> <td>1 µA</td> </tr> <tr> <td>Resistive</td> <td>30-250kΩ</td> <td>+/-2%</td> <td>1 Ω</td> </tr> <tr> <td>Frequency</td> <td>1Hz-10kHz</td> <td>+/-0.1%</td> <td>0.01%</td> </tr> <tr> <td>PWM</td> <td>Frequency</td> <td>+/-0.1%</td> <td>0.01%</td> </tr> </tbody> </table>	Input Type	Input Range	Accuracy	Resolution	Voltage	0-5V, 0-10V	+/-0.2%	1 mV	Current	0(4)-20mA	+/-0.2%	1 µA	Resistive	30-250kΩ	+/-2%	1 Ω	Frequency	1Hz-10kHz	+/-0.1%	0.01%	PWM	Frequency	+/-0.1%	0.01%
Input Type	Input Range	Accuracy	Resolution																						
Voltage	0-5V, 0-10V	+/-0.2%	1 mV																						
Current	0(4)-20mA	+/-0.2%	1 µA																						
Resistive	30-250kΩ	+/-2%	1 Ω																						
Frequency	1Hz-10kHz	+/-0.1%	0.01%																						
PWM	Frequency	+/-0.1%	0.01%																						

Table 1.0 –User Programmable Universal Inputs

Analog & Digital Input Functions	Voltage Input, Current Input, Resistive Input or Digital Input 12-bit Analog to Digital																																												
Voltage Input	0-5 V (Impedance > 1 GΩ or 10 kΩ pull-down) 0-10 V (Impedance 204 kΩ)																																												
Current Input	0-20 mA (Impedance 249 Ω) 4-20 mA (Impedance 249 Ω)																																												
Resistive	30 Ohms to 250 kOhms Self-calibrating																																												
Digital Input	Active High or Active Low with 10 kΩ pull-up or pull-down Accepts up to Vps																																												
PWM Input	1 Hz to 25 kHz 0 to 100% D.C. (Impedance 200 kΩ)																																												
Frequency/RPM Input	1 Hz to 25 kHz																																												
Maximum and Minimum Ratings	<table border="1"> <thead> <tr> <th>Characteristic</th> <th>Min</th> <th>Max</th> <th>Units</th> </tr> </thead> <tbody> <tr> <td>Power Supply</td> <td>9</td> <td>36</td> <td>V dc</td> </tr> <tr> <td>Voltage Input</td> <td>0</td> <td>36</td> <td>V dc</td> </tr> <tr> <td>Current Input 0(4)-20 mA</td> <td>0</td> <td>12</td> <td>Vdc</td> </tr> <tr> <td>Current Input 0-200 mA</td> <td>0</td> <td>1V</td> <td>Vdc</td> </tr> <tr> <td>Resistive Input</td> <td>20</td> <td>250 000</td> <td>Ω</td> </tr> <tr> <td>Digital Input</td> <td>0</td> <td>36</td> <td>Vdc</td> </tr> <tr> <td>PWM Duty Cycle</td> <td>0</td> <td>100</td> <td>%</td> </tr> <tr> <td>PWM Frequency</td> <td>5</td> <td>25 000</td> <td>Hz</td> </tr> <tr> <td>PWM Voltage pk - pk</td> <td>0</td> <td>36</td> <td>V dc</td> </tr> <tr> <td>RPM Frequency</td> <td>0.5</td> <td>10 000</td> <td>Hz</td> </tr> </tbody> </table>	Characteristic	Min	Max	Units	Power Supply	9	36	V dc	Voltage Input	0	36	V dc	Current Input 0(4)-20 mA	0	12	Vdc	Current Input 0-200 mA	0	1V	Vdc	Resistive Input	20	250 000	Ω	Digital Input	0	36	Vdc	PWM Duty Cycle	0	100	%	PWM Frequency	5	25 000	Hz	PWM Voltage pk - pk	0	36	V dc	RPM Frequency	0.5	10 000	Hz
Characteristic	Min	Max	Units																																										
Power Supply	9	36	V dc																																										
Voltage Input	0	36	V dc																																										
Current Input 0(4)-20 mA	0	12	Vdc																																										
Current Input 0-200 mA	0	1V	Vdc																																										
Resistive Input	20	250 000	Ω																																										
Digital Input	0	36	Vdc																																										
PWM Duty Cycle	0	100	%																																										
PWM Frequency	5	25 000	Hz																																										
PWM Voltage pk - pk	0	36	V dc																																										
RPM Frequency	0.5	10 000	Hz																																										

General Specifications:

Microprocessor	STM32F405RG
Typical Quiescent Current	51.51 mA @ 12Vdc typical; 27.2 mA @ 24Vdc typical
Control Logic	Standard embedded software is provided. (Application-specific control logic or a set point file is available on request.)
Communications	1 CAN port (SAE J1939) (CANopen® on request)
Baud Rate	CAN Baud rate: 250, 500, 667 kbit/s, 1 Mbit/s. Automatic baud rate detection.

Network Termination	It is necessary to terminate the network with external termination resistors. The resistors are 120 Ohm, 0.25W minimum, metal film or similar type. They should be placed between CAN_H and CAN_L terminals at both ends of the network.																										
User Interface and Software Reflashing	The Electronic Assistant, P/N: AX070502 , for <i>Windows</i> operating systems comes with a royalty-free license for use on multiple computers. It includes an Axiomatic USB-CAN converter to link the device's CAN port to a <i>Windows</i> -based PC.																										
Operating Conditions	-40 to 85 °C (-40 to 185 °F)																										
Storage Temperature	-55 to 125 °C (-67 to 257°F)																										
Protection	IP67																										
Vibration	MIL-STD-202G, Test 204D and 214A (Sine and Random) 10 g peak (Sine) 7.86 Grms peak (Random)																										
Shock	MIL-STD-202G, Test 213B 50g																										
Weight	0.15 lb. (0.068 kg) preliminary																										
Enclosure	Molded Enclosure, integral connector Nylon 6/6, 30% glass Ultrasonically welded 3.54 x 2.75 x 1.31 inches (90.09 x 70.00 x 33.35 mm) L x W x H including integral connector Refer to the dimensional drawing.																										
Electrical Connections	Integral TE Deutsch 12 pin receptacle (P/N: DTM04-12PA) <table border="1" data-bbox="440 730 938 1115"> <thead> <tr> <th>PIN #</th> <th>FUNCTION</th> </tr> </thead> <tbody> <tr> <td>1</td> <td>BATT -</td> </tr> <tr> <td>2</td> <td>+8V Reference</td> </tr> <tr> <td>3</td> <td>Input Ground</td> </tr> <tr> <td>4</td> <td>Input Ground</td> </tr> <tr> <td>5</td> <td>Input Ground</td> </tr> <tr> <td>6</td> <td>Universal Signal Input 1</td> </tr> <tr> <td>7</td> <td>Universal Signal Input 2</td> </tr> <tr> <td>8</td> <td>Universal Signal Input 4</td> </tr> <tr> <td>9</td> <td>Universal Signal Input 3</td> </tr> <tr> <td>10</td> <td>CAN_H</td> </tr> <tr> <td>11</td> <td>CAN_L</td> </tr> <tr> <td>12</td> <td>BATT +</td> </tr> </tbody> </table>	PIN #	FUNCTION	1	BATT -	2	+8V Reference	3	Input Ground	4	Input Ground	5	Input Ground	6	Universal Signal Input 1	7	Universal Signal Input 2	8	Universal Signal Input 4	9	Universal Signal Input 3	10	CAN_H	11	CAN_L	12	BATT +
PIN #	FUNCTION																										
1	BATT -																										
2	+8V Reference																										
3	Input Ground																										
4	Input Ground																										
5	Input Ground																										
6	Universal Signal Input 1																										
7	Universal Signal Input 2																										
8	Universal Signal Input 4																										
9	Universal Signal Input 3																										
10	CAN_H																										
11	CAN_L																										
12	BATT +																										
Mating Plug Kit	PL-DTM06-12SA Mating Plug Kit :1 DTM06-12SA, 1 WM-12S, 12 0462-201-20141, 6 0413-204-2005 Sealing Plug																										
Mounting	Mounting holes are sized for #8 or M4 bolts. The bolt length will be determined by the end-user's mounting plate thickness. The mounting flange of the controller is 0.425 inches (10.8 mm) thick. If the module is mounted without an enclosure, it should be mounted vertically with connectors facing left or right to reduce likelihood of moisture entry. The CAN wiring is considered intrinsically safe. The power wires are not considered intrinsically safe and so in hazardous locations, they need to be located in conduit or conduit trays at all times. The module must be mounted in an enclosure in hazardous locations for this purpose. No wire or cable harness should exceed 30 meters in length. The power input wiring should be limited to 10 meters. All field wiring should be suitable for the operating temperature range. Install the unit with appropriate space available for servicing and for adequate wire harness access (6 inches or 15 cm) and strain relief (12 inches or 30 cm).																										

7. VERSION HISTORY

Version	Date	Author	Modifications
1	August 20 th , 2021	Dmytro Tsebrii	Initial Draft
1A	September 09 th , 2021	Dmytro Tsebrii	Added the information to a CAN Transmit Function Block section. Changed the product drawing
2	October 07 th , 2021	Dmytro Tsebrii	Added a feature to switch between 5V and 8V reference. Updated the screenshots.
2A	October 12 th , 2021	Dmytro Tsebrii	Updated Technical specification section.
2B	November 1 st , 2021	Dmytro Tsebrii	Updated Technical specification section. Changed the name of the ECU
2C	March 17 th , 2022	Dmytro Tsebrii	Added the Power Supply Reading and Temperature Reading to the control source list

OUR PRODUCTS

AC/DC Power Supplies
Actuator Controls/Interfaces
Automotive Ethernet Converters
Battery Chargers
CAN Controls, Routers, Repeaters
CAN/WiFi, CAN/Bluetooth, Routers
Current/Voltage Converters
DC/DC Power Converters
Engine Temperature Scanners
Ethernet/CAN Converters,
Gateways, Switches
Fan Drive Controllers
Gateways, CAN/Modbus Protocols
Gyroscope Inclinometers
Hydraulic Valve Controllers
Inclinometers, Triaxial
I/O Controls
LVDT Signal Converters
Machine Controls
Modbus Controls
Motor Controls
Power Supplies, DC/DC, AC/DC
PWM Signal Converters/Isolators
Resolver Signal Conditioners
Service Tools
Signal Conditioners, Converters
Strain Gauge CAN Controls
Surge Suppressors

OUR COMPANY

Axiomatic provides electronic machine control components to the off-highway, commercial vehicle, electric vehicle, power generator set, material handling, renewable energy and industrial OEM markets. ***We innovate with engineered and off-the-shelf machine controls that add value for our customers.***

QUALITY DESIGN AND MANUFACTURING

We have an ISO9001:2015 registered design/manufacturing facility in Canada.

WARRANTY, APPLICATION APPROVALS/LIMITATIONS

Axiomatic Technologies Corporation reserves the right to make corrections, modifications, enhancements, improvements, and other changes to its products and services at any time and to discontinue any product or service without notice. Customers should obtain the latest relevant information before placing orders and should verify that such information is current and complete. Users should satisfy themselves that the product is suitable for use in the intended application. All our products carry a limited warranty against defects in material and workmanship. Please refer to our Warranty, Application Approvals/Limitations and Return Materials Process at <https://www.axiomatic.com/service/>.

COMPLIANCE

Product compliance details can be found in the product literature and/or on axiomatic.com. Any inquiries should be sent to sales@axiomatic.com.

SAFE USE

All products should be serviced by Axiomatic. Do not open the product and perform the service yourself.



This product can expose you to chemicals which are known in the State of California, USA to cause cancer and reproductive harm. For more information go to www.P65Warnings.ca.gov.

SERVICE

All products to be returned to Axiomatic require a Return Materials Authorization Number (RMA#) from sales@axiomatic.com. Please provide the following information when requesting an RMA number:

- Serial number, part number
- Hours of operation, description of problem
- Wiring set up diagram, application and other comments as needed

DISPOSAL

Axiomatic products are electronic waste. Please follow your local environmental waste and recycling laws, regulations and policies for safe disposal or recycling of electronic waste.

CONTACTS

Axiomatic Technologies Corporation
5915 Wallace Street
Mississauga, ON
CANADA L4Z 1Z8
TEL: +1 905 602 9270
FAX: +1 905 602 9279
www.axiomatic.com
sales@axiomatic.com

Axiomatic Technologies Oy
Höytämöntie 6
33880 Lempäälä
FINLAND
TEL: +358 103 375 750
FAX: +358 3 3595 660
www.axiomatic.com
salesfinland@axiomatic.com