



**USER MANUAL UMAX032000**  
**USER MANUAL UMAX032050**  
Version V2

# **18/16 CELL BATTERY SUBSTACK VOLTAGE MONITOR**

With SAEJ1939®

## **USER MANUAL**

**P/N: AX032000 – 18-Cell Battery Monitor**  
**P/N: AX032050 – 16-Cell Battery Monitor**

---

**In Europe:**  
Axiomatic Technologies Oy  
Höytämöntie 6  
33880 LEMPÄÄLÄ - Finland  
Tel. +358 103 375 750  
Fax. +358 3 3595 660  
[www.axiomatic.fi](http://www.axiomatic.fi)

**In North America:**  
Axiomatic Technologies Corporation  
5915 Wallace Street  
Mississauga, ON Canada L4Z 1Z8  
Tel. 1 905 602 9270  
Fax. 1 905 602 9279  
[www.axiomatic.com](http://www.axiomatic.com)

## ACCRONYMS

|       |   |
|-------|---|
| ACK   | Positive Acknowledgement (from SAE J1939 standard)  |
| CAN   | Controller Area Network   |
| DM    | Diagnostic Message (from SAE J1939 standard)  |
| DTC   | Diagnostic Trouble Code   |
| EA    | Electronic Assistant <sup>®</sup> , p/n AX070502 (A Service Tool for Axiomatic ECUs)  |
| ECU   | Electronic Control Unit (from SAE J1939 standard)   |
| FMI   | Failure Mode Identifier   |
| NAK   | Negative Acknowledgement (from SAE J1939 standard)  |
| PDU1  | A format for messages that are to be sent to a destination address, either specific or global (from SAE J1939 standard)                 |
| PDU2  | A format used to send information that has been labeled using the Group Extension technique and does not contain a destination address. |
| PGN   | Parameter Group Number (from SAE J1939 standard)  |
| PropA | Message that uses the Proprietary A PGN for peer-to-peer communication  |
| PropB | Message that uses a Proprietary B PGN for broadcast communication   |
| PWM   | Pulse Width Modulation  |
| OC    | Occurrence Count  |
| SPN   | Suspect Parameter Number (from SAE J1939 standard)  |
| VPS   | Voltage Power Supply  |

# TABLE OF CONTENTS

|  |                                     |
|--|-------------------------------------|
| <b>1. GENERAL INFORMATION</b>  | <b>4</b>                            |
| 1.1. Description of Battery Substack Voltage Monitor   | 4                                   |
| 1.2. Cell Group Input Function Block   | 5                                   |
| 1.3. Cell Input Function Block   | 6                                   |
| 1.4. Diagnostic Input Function Block   | 7                                   |
| 1.5. CAN Transmit Function Block   | 9                                   |
| 1.6. CAN Receive Function Block  | 11                                  |
| <b>2. OVERVIEW OF J1939 FEATURES</b>   | <b>13</b>                           |
| 2.1. Introduction to Supported Messages  | 13                                  |
| 2.2. Name, Address and Software ID   | 13                                  |
| 2.2.3. J1939 Name  | 13                                  |
| 2.2.3. ECU Address   | 14                                  |
| 2.2.3. Software Identifier   | 14                                  |
| <b>3. ECU SETPOINTS ACCESSED WITH ELECTRONIC ASSISTANT</b>   | <b>16</b>                           |
| 3.1. J1939 Network Setpoints   | 17                                  |
| 3.2. Cell Group Input Setpoints  | 16                                  |
| 3.3. Cell Input Setpoints  | 17                                  |
| 3.4. Diagnostic Input Setpoints  | 18                                  |
| 3.5. CAN Transmit Setpoints  | 18                                  |
| 3.6. CAN Receive Setpoints   | 20                                  |
| <b>4. REFLASHING OVER CAN WITH EA  BOOTLOADER</b> | <b>22</b>                           |
| <b>5. INSTALLATION INSTRUCTIONS</b>  | <b>27</b>                           |
| <b>6. TECHNICAL SPECIFICATIONS</b>   | <b>ERROR! BOOKMARK NOT DEFINED.</b> |
| 6.1. Input Specifications  | 29                                  |
| 6.2. General Specifications  | 29                                  |
| <b>7. VERSION HISTORY</b>  | <b>30</b>                           |

# 1. GENERAL INFORMATION

## 1.1. Description of Battery Substack Voltage Monitor

The Battery Substack Voltage Monitor (BATT-MON) Controller is designed to provide a J1939 CAN network interface for a controller to monitor and control up to 18 battery cells for back-up power or fuel systems.

Each battery cell can measure up to 5V, allowing the BATT-MON Controller to monitor up to 90V in total. In addition to monitoring the voltage of a cell, the BATT-MON Controller has a configurable cell balancing algorithm which is automated by default but allows for partial to full user-control.

For systems involving more than 18 cells and monitoring higher than 90V, multiple AX0320x0 units can be stacked in series to expand the monitoring coverage.

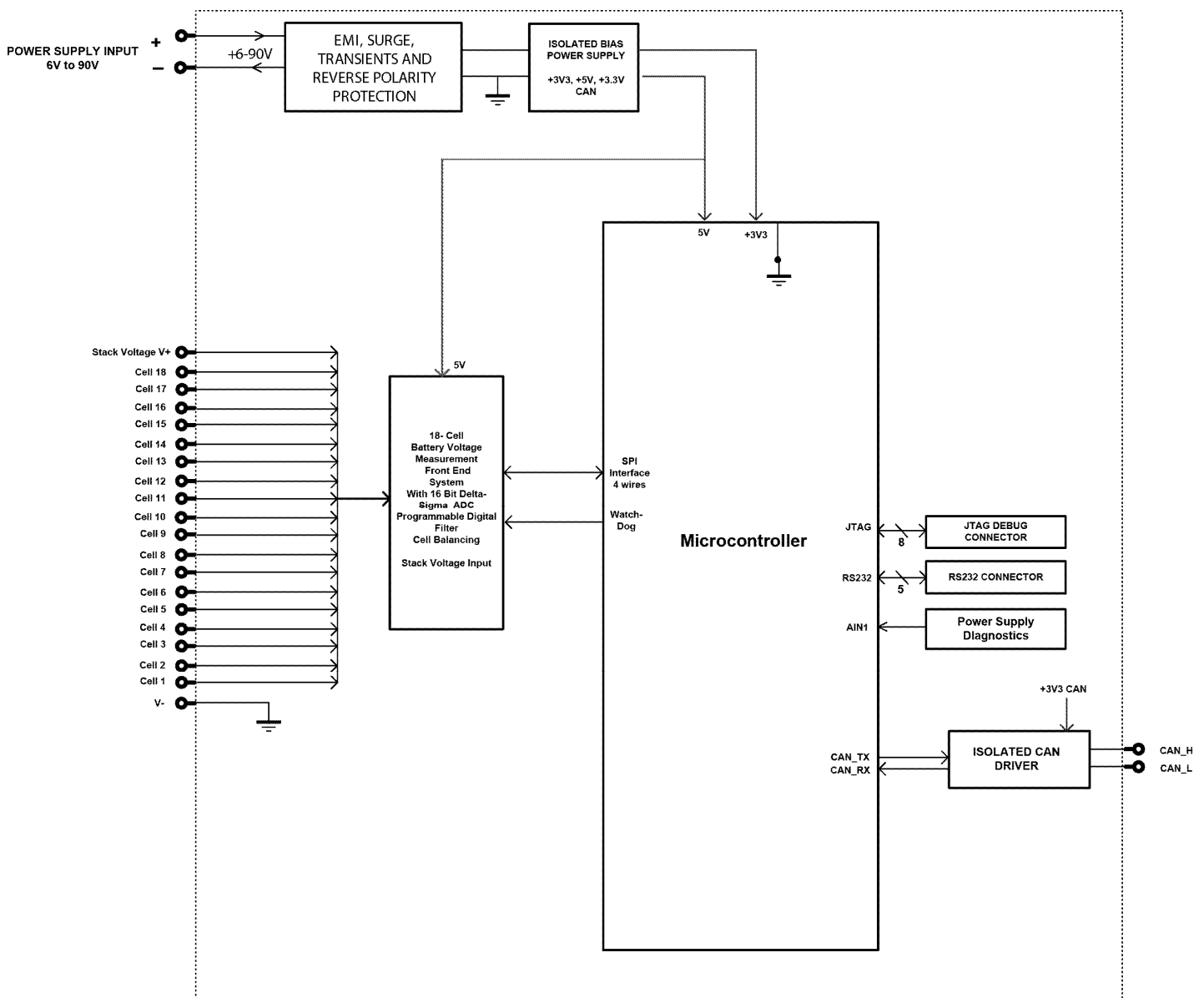

Figure 1 – Hardware Functional Block Diagram

The cell voltages are sampled within 25ms and are available for transmission on a single CAN port at a 250kHz baud rate.

The BATT-MON Controller can be ordered using the following part numbers depending on the application.

|          |                         |
|----------|-------------------------|
| AX032000 | 18-Cell Battery Monitor |
| AX032050 | 16-Cell Battery Monitor |

## 1.2. Cell Group Input Function Block

The Cell Group Input function block is used to configure data that applies to the function of all the cells as a group.

The **Monitor Only Setting** parameter allows for the features of the BATT-MON to be simplified so that no user control or self-balancing is implemented, and the controller only acts as a monitor. With this setting set to true cells cannot be controlled by CAN Receive messages and cannot be set to discharge automatically.

The **Cell Overvoltage** parameter controls how much voltage each individual cell can store before it will discharge. This value only applies to cells which are enabled and under automated control. If a cell's voltage is below this value it will be in a charging state, and if its voltage is above this value it will be in a discharging state. The discharge rate of a cell is determined in proportion to the cell overvoltage value, and is calculated as such:

$$\text{Discharge Rate} = \frac{\text{Cell Voltage} - \text{Overvoltage}}{4.5 - \text{Overvoltage}}$$

The Discharge Rate is then rounded up to the nearest 1/15 (6.67%) increment and applied to the cell.

In addition to each cell being in a discharging state, cells can be flagged as having undervoltage. The **Cell Undervoltage** parameter sets a global value for each cell to be compared against. If a cell's voltage is below the set Undervoltage value, the cell's corresponding flag is set and will be reported in a Diagnostic Message (DM1) based on the settings provided in diagnostic section of that cell's Cell Input function block.

The **VPS Overvoltage & VPS Undervoltage** parameters are used as values to flag when there is a Total Bank Voltage (V+/V-) error. When flagged, a DM1 message will be produced based on the diagnostic information set in the VPS Overvoltage Fault and VPS Undervoltage Fault function blocks. Similarly, the **Shutdown Temperature** parameter is used to flag when there is an Internal Temperature error. An error will trigger a DM1 message based on the settings provided in the Over Temperature Fault function block.

The **Rx Timeout Discharge Setting** parameter determines how a cell will operate if it is being user-controlled and the CAN Receive associated with that cell as a PWM Value Source times out. Table 1 shows the possible settings.

| Value | Meaning                        |
|-------|--------------------------------|
| 0     | Set Discharge Rate(s) to 0     |
| 1     | Automated Discharge Control    |
| 2     | Revert to last stored value(s) |

**Table 1 – Rx Timeout Discharge Settings**

The “Set Discharge Rate(s) to 0” setting will set the discharge rate of all user-controlled cells with CAN Receive sources that have timed out to 0 (they will not discharge). The “Automated Discharge Control” setting will make the user-controlled cells with CAN Receive sources that have timed out operate as though they were under automated control (discharge proportionally to the set Cell Overvoltage). The “Revert to last stored value(s)” setting will set the discharge rate of all user-controlled cells with CAN Receive sources that have timed out to the last value that was sent via the cell’s respective CAN Receive before the timeout occurred. If a new CAN Receive message is sent to clear the Lost Communication error, the discharge rate will return to being User-Controlled, and the setting will only apply while the CAN Receive Timeout is active.

The **Open Wire Check Period** parameter determines how often open wire checking is performed within the regular run cycle of the balancing algorithm. When this parameter is set to 0 seconds, open wire checking is not performed. Having the period set as low as possible (but above 0 seconds) will have a greater effect on the regular performance of the monitor. Regular cell readings are sampled within 25ms but while checking for open wires, cell readings are sampled at a rate of 200ms. So, at the start of a new period, the monitor will perform 4 conversions at 200ms to detect possible open wires at the cell inputs, and then revert to the regular 25ms sample rate for the remainder of the period. As such it is recommended to set the period as large as possible, or to 0, if keeping a more frequent sampling rate is more important than checking for open inputs.

If true, the **Block Empty DM1 Messages** parameter will block DM1 messages with no data, or with DM1 messages that have a set SPN of 0x00000. If false, all DM1 messages, including ones that report no data, will continue to be sent at their normal rate of 1 second.

### 1.3. Individual Cell Input Function Block

The Cell Input functions blocks for each individual cell are used to configure the operation of an individual cell, and setup the diagnostic message for that cell.

The first parameter, **Enable Cell**, is the most important in determining how the cell will operate. Disabled cells will not have their voltage reported, cannot be controlled by the user, and will report a zero value in any CAN Transmit message involved with that cell.

If a cell is enabled, it can be configured to one of two settings through the **Discharge Control** parameter, as shown in Table 2.

| Value | Meaning         |
|-------|-----------------|
| 0     | Automated       |
| 1     | User-Controlled |

Table 2 – Discharge Control Options

A cell with a setting of *Automated* will have its discharge rate calculated automatically based on the set Cell Overvoltage set in the Cell Group function block. A *User-Controlled* cell will be in a discharging state and will be set to a value given by its CAN Receive source.

If a cell is both enabled and set to User-Controlled, the **Discharge Value Source** parameter will control which CAN Receive message will be used as the source for that cell’s discharge value. Once set, the discharge rate value will be determined by taking the received data as a percentage of the set Data Minimum and Data Maximum parameters of that CAN Receive and rounding up to the nearest 1/15 (6.67%) increment.

$$\text{Discharge Rate} = \frac{\text{CAN Receive Data}}{\text{Data Maximum} - \text{Data Minimum}}$$

The remaining setpoints in this function block control the settings of the diagnostic message associated with the cell and are explained along with the other Diagnostic Input function blocks in the following section.

#### 1.4. Diagnostic Input Function Blocks

The Diagnostic Input function blocks are used to setup the diagnostic messages for the controller.

The 5 types of diagnostics supported by the BATT-MON Controller are shown in Table 3.

| Function Block           | Minimum Threshold | Maximum Threshold              |
|--------------------------|-------------------|--------------------------------|
| Cell Voltage Fault       | Cell Undervoltage | N/A                            |
| VPS Undervoltage Fault   | VPS Undervoltage  | N/A                            |
| VPS Overvoltage Fault    | N/A               | VPS Overvoltage                |
| Over Temperature Fault   | N/A               | Temperature Shutdown           |
| Lost Communication Fault | N/A               | Received Message Timeout (any) |

Table 3 – Fault Detection Thresholds

If and only if the **Event Generates a DTC in DM1** parameter is set to true will the other setpoints in the function block be enabled. They are all related to the data that's is sent to the J1939 network as part of the DM1 message, Active Diagnostic Trouble Codes.

A Diagnostic Trouble Code (DTC) is defined by the J1939 standard as a 4-byte value which is a combination of:

|     |                          |  |
|-----|--------------------------|--|
| SPN | Suspect Parameter Number | (first 19 bits of the DTC, LSB first)            |
| FMI | Failure Mode Identifier  | (next 5 bits of the DTC)                         |
| CM  | Conversion Method        | (1 bit, always set to 0)                         |
| OC  | Occurrence Count         | (7 bits, number of times the fault has happened) |

In addition to supporting the DM1 message, the BATT-MON Controller also supports

|      |   |                             |
|------|---|-----------------------------|
| DM2  | Previously Active Diagnostic Trouble Codes            | <b>Sent only on request</b> |
| DM3  | Diagnostic Data Clear/Reset of Previously Active DTCs | <b>Done only on request</b> |
| DM11 | Diagnostic Data Clear/Reset for Active DTCs           | <b>Done only on request</b> |

So long as even one Diagnostic function block has **Event Generates a DTC in DM1** set to true, the BATT-MON Controller will send the DM1 message every one second, regardless of whether there are any active faults, as recommended by the standard. While there are no active DTCs, the BATT-MON will send the "No Active Faults" message. If a previously active DTC becomes inactive, a DM1 will be sent immediately to reflect this. As soon as the last active DTC goes inactive, it will send a DM1 indicating that there are no more active DTCs.

If there is more than one active DTC at any given time, the regular DM1 message will be sent using a multipacket Broadcast Announce Message (BAM). If the controller receives a request for a DM1 while this is true, it will send the multipacket message to the Requester Address using the Transport Protocol (TP).



At power up, the DM1 message will not be broadcast until after a 5 second delay. This is done to prevent any power up or initialization conditions from being flagged as an active error on the network.

The Diagnostic function block has a setpoint **Event Cleared Only by DM11**. By default, this is set to false, which means that as soon as the condition that caused an error flag to be set goes away, the DTC is automatically made Previously Active, and is no longer included in the DM1 message. However, when this setpoint is set to true, even if the flag is cleared, the DTC will not be made inactive, so it will continue to be sent on the DM1 message. Only when a DM11 has been requested will the DTC go inactive. This feature may be useful in a system where a critical fault needs to be clearly identified as having happened, even if the conditions that caused it went away.

In addition to all the active DTCs, another part of the DM1 message is the first byte, which reflects the Lamp Status. Each Diagnostic function block has the setpoint **Lamp Set by Event in DM1** which determines which lamp will be set in this byte while the DTC is active. The J1939 standard defines the lamps as '*Malfunction*', '*Red Stop*', '*Amber, Warning*' or '*Protect*'. By default, the '*Amber, Warning*' lamp is typically the one set by any active fault.

By default, every Diagnostic function block has associated with it a proprietary SPN. However, this setpoint **SPN for Event used in DTC** is fully configurable by the user should they wish it to reflect a standard SPN define in J1939-71 instead. If the SPN is change, the OC of the associate error log is automatically reset to zero.

Every Diagnostic function block also has associated with it a default FMI. The only setpoint for the user to change the FMI is **FMI for Event used in DTC**, even though some Diagnostic function blocks can have both high and low errors. In those cases, the FMI in the setpoint reflects that of the low-end condition, and the FMI used by the high fault will be determined per Table 4. If the FMI is changed, the OC of the associate error log is automatically reset to zero.

| <b>FMI for Event used in DTC – Low Fault</b>                                  | <b>Corresponding FMI used in DTC – High Fault</b>                             |
|---|---|
| FMI=1, Data Valid But Below Normal Operational Range – Most Severe Level      | FMI=0, Data Valid But Above Normal Operational Range – Most Severe Level      |
| FMI=4, Voltage Below Normal, Or Shorted To Low Source                         | FMI=3, Voltage Above Normal, Or Shorted To High Source                        |
| FMI=5, Current Below Normal Or Open Circuit                                   | FMI=6, Current Above Normal Or Grounded Circuit                               |
| FMI=17, Data Valid But Below Normal Operating Range – Least Severe Level      | FMI=15, Data Valid But Above Normal Operating Range – Least Severe Level      |
| FMI=18, Data Valid But Below Normal Operating Range – Moderately Severe Level | FMI=16, Data Valid But Above Normal Operating Range – Moderately Severe Level |
| FMI=21, Data Drifted Low  | FMI=20, Data Drifted High   |

**Table 4 – Low Fault FMI versus High Fault FMI**



If the FMI used is anything other than one of those in Table 4, then both the low and the high faults will be assigned the same FMI. This condition should be avoided, as the log will still use different OC for the two types of faults, even though they will be reported the same in the DTC. It is the user's responsibility to make sure this does not happen.

When the fault is linked to a DTC, a non-volatile log of the occurrence count (OC) is kept. As soon as the controller detects a new (previously inactive) fault, it will start decrementing the **Delay Before Sending DM1** timer for the Diagnostic function block. If the fault has remained present during the delay time, then the controller will set the DTC to active, and it will increment the OC in the log. A DM1 will immediately be generated that includes the new DTC. The timer is provided so that intermittent faults do not overwhelm the network as the fault comes and goes, since a DM1 message would be sent every time the fault shows up or goes away.

### 1.5. CAN Transmit Function Block

The CAN Transmit function block is used to send data from the BATT-MON to the J1939 network.

Normally, to disable a transmit message, the **Transmit Repetition Rate** is set to zero. However, should the message share its Parameter Group Number (PGN) with another message, this is not necessarily true. In the case where multiple messages share the same **Transmit PGN**, the repetition rate selected in the message with the LOWEST number will be used for ALL the messages that use that PGN.

By default, all messages are sent on Proprietary B PGNs as broadcast messages. If all the data is not necessary, disable the entire message by setting the lowest channel using that PGN to zero. If some of the data is not necessary, simply change the PGN of the superfluous channel(s) to an unused value in the Proprietary B range.

Since the defaults are PropB messages, the **Transmit Message Priority** is always initialized to 6 (low priority) and the **Destination Address (for PDU1)** setpoint is not used. This setpoint is only valid when a PDU1 PGN has been select, and it can be set either to the Global Address (0xFF) for broadcasts or sent to a specific address as setup by the user.

Enabling the **Override Source Address**, allows the **Source Address** of the J1939 Identifier to be changed to any value between 0...255.

The **Transmit Data Size**, **Transmit Data Index in Array (LSB)**, **Transmit Bit Index in Byte (LSB)**, **Transmit Resolution** and **Transmit Offset** can all be used to map the data to any SPN supported message by the J1939 standard from any **Data Source** of the Transmit function block. Table 5 exhibits the possible **Data Sources** for use in CAN Transmits.

| Value | 18-Cell BATT-MON         | 16-Cell BATT-MON |
|-------|--------------------------|------------------|
|       | CAN Transmit Data Source |                  |
| 0     | Control Not Used         | Control Not Used |
| 1     | Cell Voltage 1           | Cell Voltage 1   |
| 2     | Cell Voltage 2           | Cell Voltage 2   |
| 3     | Cell Voltage 3           | Cell Voltage 3   |
| 4     | Cell Voltage 4           | Cell Voltage 4   |

|    |                             |                             |
|----|-----------------------------|-----------------------------|
| 5  | Cell Voltage 5              | Cell Voltage 5              |
| 6  | Cell Voltage 6              | Cell Voltage 6              |
| 7  | Cell Voltage 7              | Cell Voltage 7              |
| 8  | Cell Voltage 8              | Cell Voltage 8              |
| 9  | Cell Voltage 9              | Cell Voltage 9              |
| 10 | Cell Voltage 10             | Cell Voltage 10             |
| 11 | Cell Voltage 11             | Cell Voltage 11             |
| 12 | Cell Voltage 12             | Cell Voltage 12             |
| 13 | Cell Voltage 13             | Cell Voltage 13             |
| 14 | Cell Voltage 14             | Cell Voltage 14             |
| 15 | Cell Voltage 15             | Cell Voltage 15             |
| 16 | Cell Voltage 16             | Cell Voltage 16             |
| 17 | Cell Voltage 17             | Total Bank Voltage (V+/V-)  |
| 18 | Cell Voltage 18             | Internal Temperature        |
| 19 | Total Bank Voltage (V+/V-)  | Discharging Cells Indicator |
| 20 | Internal Temperature        | Open Wire Indicator         |
| 21 | Discharging Cells Indicator | Total Summed Voltage        |
| 22 | Open Wire Indicator         |                             |
| 23 | Total Summed Voltage        |                             |

**Table 5 – CAN Transmit Data Sources**

The *Cell Voltage* data sources give the 0 to 5V reading for each cell in terms of mV (a resolution of 0.001). The *Total Bank Voltage (V+/V-)* and *Internal Temperature* data sources have ranges of 0 to 90V and -45 to 150°C respectively, with the temperature reading also being offset by -45°C, and both sources having a resolution of 0.01. The *Discharging Cells Indicator* data source gives an 18-bit value with each bit representing whether its corresponding cell is currently discharging. For example, bit 0 (the least significant bit) will be 1 when Cell 1 is discharging, and 0 when it is not, and bit 17 (the most significant bit) follows the same logic but with Cell 18. The *Open Wire Indicator* follows the same bit formatting as the discharge indicator, but instead reports a 1 when there is an open wire detected on the corresponding cell input.

The BATT-MON supports up to 10 unique CAN Transmit Messages, all of which can be programmed to send any available data to the CAN network. Each CAN Transmit Message is setup to send data from 4 configurable sources, and if each of the 4 sources is used, each source can have a size as large as 2-Bytes. Only the first 6 CAN Transmit Messages are configured by default, with the remaining 4 set to unused; the default list is shown in Table 6 below.

| CAN Transmit # | 18-Cell BATT-MON      |                 | 16-Cell BATT-MON      |                 | PGN    |
|----------------|-----------------------|-----------------|-----------------------|-----------------|--------|
|                | Default Transmit Data | Byte Position   | Default Transmit Data | Byte Position   |        |
| 1              | Cell 1 Voltage        | 1 <sup>st</sup> | Cell 1 Voltage        | 1 <sup>st</sup> | 0xFF00 |
|                | Cell 2 Voltage        | 3 <sup>rd</sup> | Cell 2 Voltage        | 3 <sup>rd</sup> |        |
|                | Cell 3 Voltage        | 5 <sup>th</sup> | Cell 3 Voltage        | 5 <sup>th</sup> |        |
|                | Cell 4 Voltage        | 7 <sup>th</sup> | Cell 4 Voltage        | 7 <sup>th</sup> |        |
| 2              | Cell 5 Voltage        | 1 <sup>st</sup> | Cell 5 Voltage        | 1 <sup>st</sup> | 0xFF01 |
|                | Cell 6 Voltage        | 3 <sup>rd</sup> | Cell 6 Voltage        | 3 <sup>rd</sup> |        |
|                | Cell 7 Voltage        | 5 <sup>th</sup> | Cell 7 Voltage        | 5 <sup>th</sup> |        |

|         |                             |                 |                             |                 |                        |
|---------|-----------------------------|-----------------|-----------------------------|-----------------|------------------------|
|         | Cell 8 Voltage              | 7 <sup>th</sup> | Cell 8 Voltage              | 7 <sup>th</sup> |                        |
| 3       | Cell 9 Voltage              | 1 <sup>st</sup> | Cell 9 Voltage              | 1 <sup>st</sup> | 0xFF02                 |
|         | Cell 10 Voltage             | 3 <sup>rd</sup> | Cell 10 Voltage             | 3 <sup>rd</sup> |                        |
|         | Cell 11 Voltage             | 5 <sup>th</sup> | Cell 11 Voltage             | 5 <sup>th</sup> |                        |
|         | Cell 12 Voltage             | 7 <sup>th</sup> | Cell 12 Voltage             | 7 <sup>th</sup> |                        |
| 4       | Cell 13 Voltage             | 1 <sup>st</sup> | Cell 13 Voltage             | 1 <sup>st</sup> | 0xFF03                 |
|         | Cell 14 Voltage             | 3 <sup>rd</sup> | Cell 14 Voltage             | 3 <sup>rd</sup> |                        |
|         | Cell 15 Voltage             | 5 <sup>th</sup> | Cell 15 Voltage             | 5 <sup>th</sup> |                        |
|         | Cell 16 Voltage             | 7 <sup>th</sup> | Cell 16 Voltage             | 7 <sup>th</sup> |                        |
| 5       | Cell 17 Voltage             | 1 <sup>st</sup> | Total Bank Voltage (V+/V-)  | 1 <sup>st</sup> | 0xFF04                 |
|         | Cell 18 Voltage             | 3 <sup>rd</sup> | Internal Temperature        | 3 <sup>rd</sup> |                        |
|         | Total Bank Voltage (V+/V-)  | 5 <sup>th</sup> | Discharging Cells Indicator | 5 <sup>th</sup> |                        |
|         | Internal Temperature        | 7 <sup>th</sup> | Control Not Used            | --              |                        |
| 6       | Discharging Cells Indicator | 1 <sup>st</sup> | Control Not Used            | --              | 0xFF05                 |
|         | Control Not Used            | --              | Control Not Used            | --              |                        |
|         | Control Not Used            | --              | Control Not Used            | --              |                        |
|         | Control Not Used            | --              | Control Not Used            | --              |                        |
| 7 to 10 | Control Not Used            | --              | Control Not Used            | --              | 0xFF06<br>to<br>0xFF09 |
|         | Control Not Used            | --              | Control Not Used            | --              |                        |
|         | Control Not Used            | --              | Control Not Used            | --              |                        |
|         | Control Not Used            | --              | Control Not Used            | --              |                        |

Table 6 – Default CAN Transmit Messages

## 1.6. CAN Receive Function Block

The CAN Receive function block is designed to take any SPN from the J1939 network and use it as a control/enable/override source for any relay outputs or CAN Transmits.

The **Receive Message Enabled** is the most important setpoint associated with this function block and it should be selected first. Changing it will result in other setpoints being enabled/disabled as appropriate. By default, all receive messages are enabled.

Once a message has been enabled, a Lost Communication fault will be flagged if that message is not received within the **Receive Message Timeout** period. This will trigger a Lost Communication event if the cell input associated with the CAN Receive message is set to User Controlled under Rx Timeout Setting. In order to avoid timeouts on a heavily saturated network, it is recommended to set the period at least three times longer than the expected update rate. To disable the timeout feature, simply set this value to zero, in which case the received message will never timeout and will never trigger a Lost Communication fault.

By default, all control messages are expected to be sent to the BATT-MON on Proprietary B PGNs. However, should a PDU1 message be selected, the BATT-MON can be setup to receive it from any ECY by setting the **Specific Address that sends the PGN** to the Global Address (0xFF). If a specific address is selected instead, then any other ECU data on the PGN will be ignored.

The **Receive Data Size**, **Receive Data Index in Array (LSB)**, **Receive Bit Index in Byte (LSB)**, **Receive Resolution** and **Receive Offset** can all be used to map any SPN supported by the J1939 standard to the output data of the Received function block.

As mentioned earlier, a CAN receive function block can be selected as the source of the control input for the output function blocks. When this is the case the **Receive Data Minimum** (Off Threshold) and **Receive Data Maximum** (On Threshold) setpoints determine the minimum and maximum values of the control signal. As the names imply, they are also used as the On/Off thresholds for digital output types. These values are in whatever units the data is AFTER the resolution and offset is applied to the CAN Receive signal. The BATT-MON supports 18 and 16 Unique CAN Receive messages for the 18-Cell BATT-MON and 16-Cell BATT-MON respectively.

## 2. OVERVIEW OF J1939 FEATURES

---

The software was designed to provide flexibility to the user with respect to messages sent to and from the ECU by providing:

- Configurable ECU Instance in the NAME (to allow multiple ECUs on the same network)
- Configurable Transmit PGN and SPN Parameters

### 2.1. Introduction to Supported Messages

The ECU is compliant with the standard SAE J1939, and supports the following PGNs

#### From J1939-21 - Data Link Layer

- Request 59904 (\$00EA00)
- Acknowledgment 59392 (\$00E800)
- Transport Protocol – Connection Management 60416 (\$00EC00)
- Transport Protocol – Data Transfer Message 60160 (\$00EB00)

Note: Any Proprietary B PGN in the range 65280 to 65535 (\$00FF00 to \$00FFFF) can be selected

#### From J1939-73 – Diagnostics

- DM1 – Active Diagnostic Trouble Codes 65226 (\$00FECA)
- DM2 – Previously Active Diagnostic Trouble Codes 65227 (\$00FECB)
- DM3 – Diagnostic Data Clear/Reset for Previously Active DTCs 65228 (\$00FECC)
- DM11 – Diagnostic Data Clear/Reset for Active DTCs 65235 (\$00FED3)

#### From J1939-81 - Network Management

- Address Claimed/Cannot Claim 60928 (\$00EE00)
- Commanded Address 65240 (\$00FED8)

#### From J1939-71 – Vehicle Application Layer

- Software Identification 65242 (\$00FEDA)

None of the application layer PGNs are supported as part of the default configurations, but they can be selected as desired for either transmit or received function blocks.

Setpoints are accessed using standard Memory Access Protocol (MAP) with proprietary addresses. The Electronic Assistant<sup>®</sup>  (EA) allows for quick and easy configuration of the unit over the CAN network.

### 2.2. NAME, Address and Software ID

#### 2.2.1. J1939 Name

The BATT-MON ECU has the following defaults for the J1939 NAME. The user should refer to the SAE J1939/81 standard for more information on these parameters and their ranges.

|                           | 18-Cell BATT-MON       | 16-Cell BATT-MON       |
|---------------------------|------------------------|------------------------|
| Arbitrary Address Capable | Yes                    | Yes                    |
| Industry Group            | 0, Global              | 0, Global              |
| Vehicle System Instance   | 0                      | 0                      |
| Vehicle System            | 0, Non-specific system | 0, Non-specific system |

|                     |   |   |
|---------------------|---|---|
| Function            | 126, Axiomatic IO Controller  | 126, Axiomatic IO Controller  |
| Function Instance   | 6, Axiomatic AX032000, Battery Monitoring System                    | 8, Axiomatic AX032050, 16-Cell Battery Monitoring System            |
| <b>ECU Instance</b> | <b>0, First Instance</b>  | <b>0, First Instance</b>  |
| Manufacture Code    | 162, Axiomatic Technologies Corporation                             | 162, Axiomatic Technologies Corporation                             |
| Identity Number     | Variable, uniquely assigned during factory programming for each ECU | Variable, uniquely assigned during factory programming for each ECU |

**Table 7 – Default J1939 NAME**

The ECU Instance is a configurable setpoint associated with the NAME. Changing this value will allow multiple ECUs of this type to be distinguishable by other ECUs (including the Electronic Assistant <sup>®</sup> (EA)) when they are all connected on the same network.

### 2.2.2. ECU Address

The default value of this setpoint is 128 (0x80), which is the preferred starting address for self-configurable ECUs as set by the SAE in J1939 tables B3 to B7. The EA will allow the selection of any address between 0 to 253, and **it is the user's responsibility to select an address that complies with the standard**. The user must also be aware that since the unit is arbitrary address capable, if another ECU with a higher priority NAME contends for the selected address, the BATT-MON will continue select the next highest address until it finds one that it can claim. See J1939/81 for more details about address claiming.

### 2.2.3. Software Identifier

|                               |                                 |   |     |
|-------------------------------|---------------------------------|---|-----|
| PGN 65242                     | Software Identification         | - SOFT  |     |
| Transmission Repetition Rate: | On request                      |   |     |
| Data Length:                  | Variable                        |   |     |
| Extended Data Page:           | 0                               |   |     |
| Data Page:                    | 0                               |   |     |
| PDU Format:                   | 254                             |   |     |
| PDU Specific:                 | 218 PGN Supporting Information: |   |     |
| Default Priority:             | 6                               |   |     |
| Parameter Group Number:       | 65242 (0xFEDA)                  |   |     |
| Start Position                | Length                          | Parameter Name                                    | SPN |
| 1                             | 1 Byte                          | Number of software identification fields          | 965 |
| 2-n                           | Variable                        | Software identification(s), Delimiter (ASCII “*”) | 234 |

For the BATT-MON ECU, Byte 1 is set to 5, and the identification fields are as follows

**(Part Number)\*(Version)\*(Date)\*(Owner)\*(Description)**

EA shows all this information in “General ECU Information”, as shown below

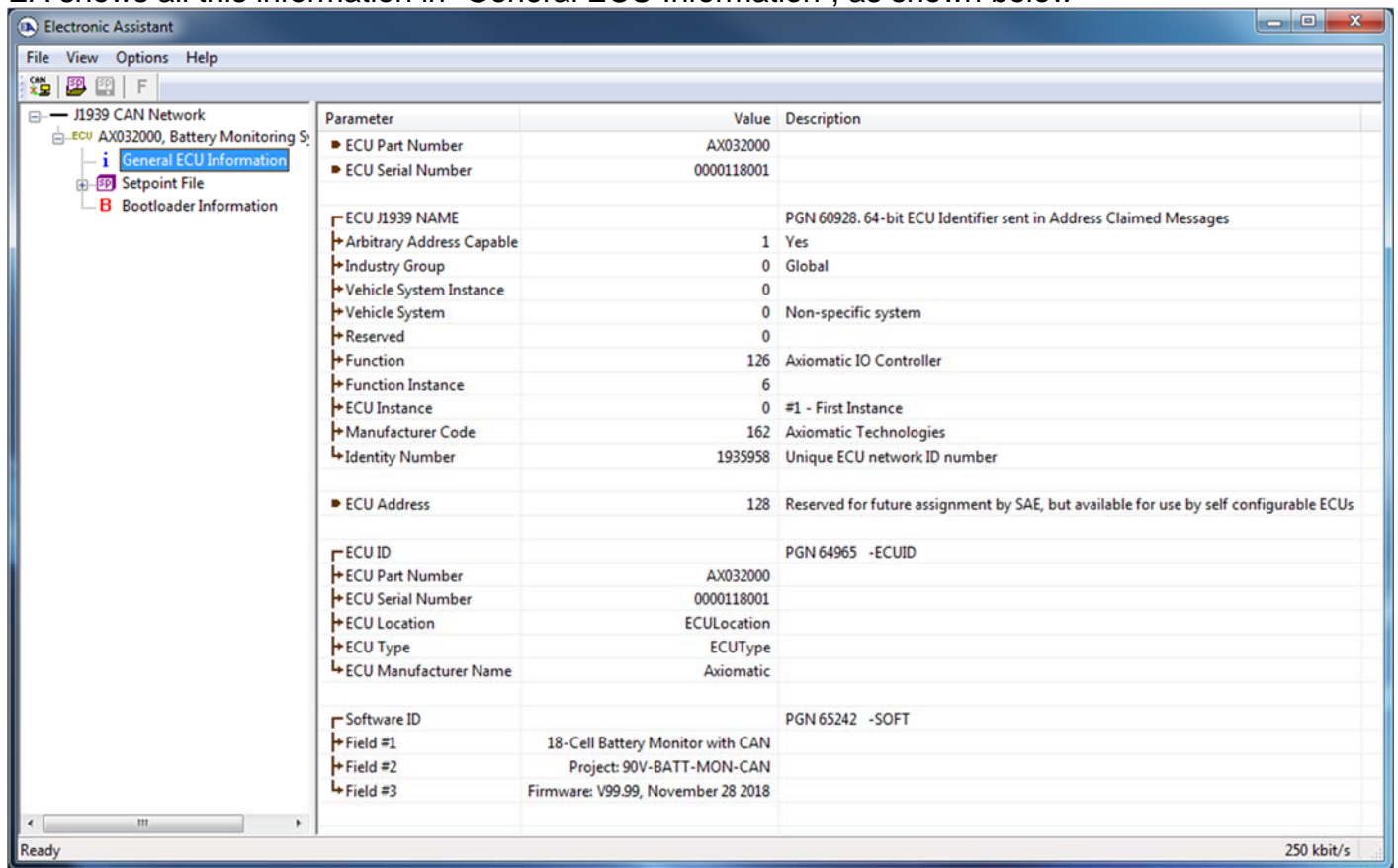

*Note: The information provided in the Software ID is available for any J1939 service tool which supports the PGN -SOFT.*

### 3. ECU SETPOINTS ACCESSED WITH ELECTRONIC ASSISTANT

Many setpoints have been referenced throughout this manual. This section describes in detail each setpoint, their defaults and ranges. For more information on how each setpoint is used by the BATT-MON, refer to the relevant section of the user manual.

#### 3.1. J1939 Network Setpoints

The J1939 Network function block is detailed in section 2.2. Please refer to that section for detailed information on how these setpoints are used

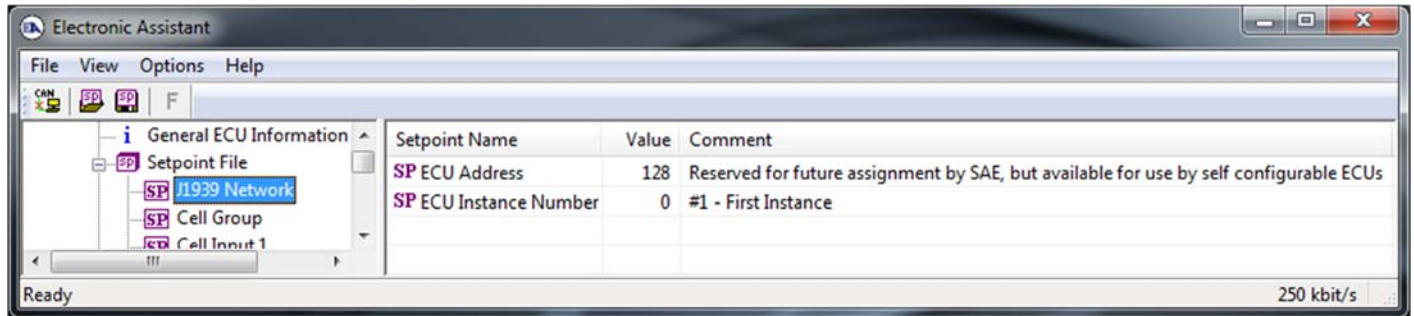

Screen Capture of Default J1939 Network Setpoints

| Name                | Range   | Default | Notes                  |
|---------------------|---------|---------|------------------------|
| ECU Address         | 0...255 | 128     | Refer to Section 2.2.2 |
| ECU Instance Number | 0...6   | 0       | Refer to Section 2.2.1 |

Table 8 – Default J1939 Network Setpoints

#### 3.2. Cell Group Input Setpoints

The Cell Group Input function block is defined in Section 1.2. Please refer to that section for detailed information on how these setpoints are used.

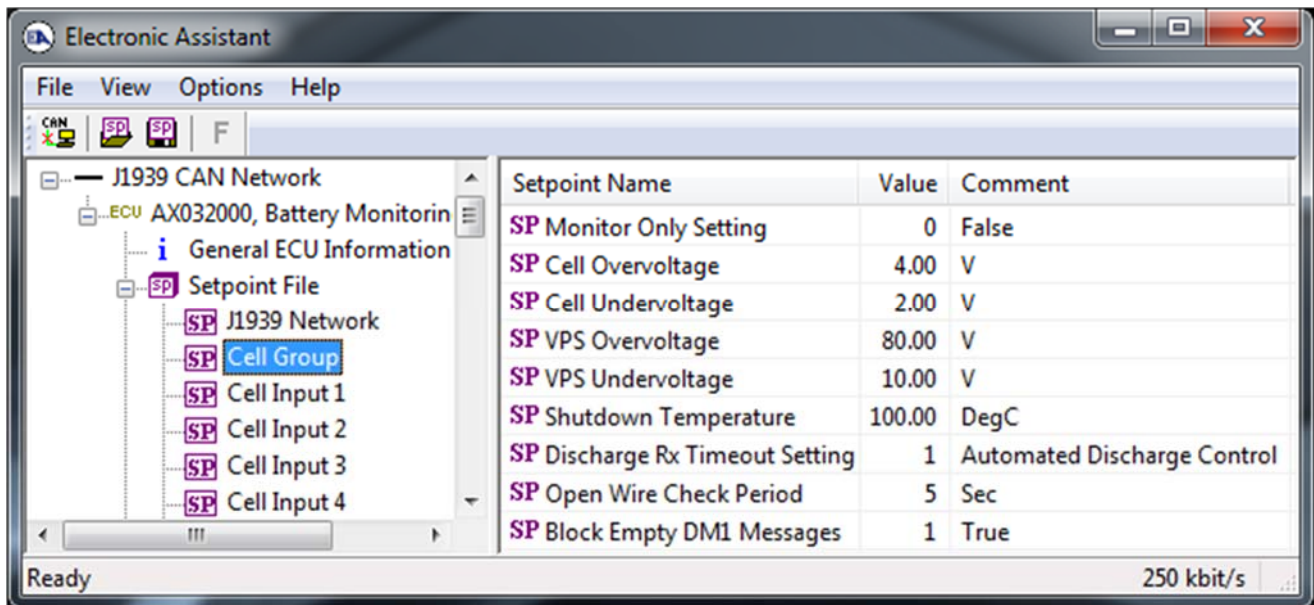

Screen Capture of Default Cell Group Input Setpoints

| Name                         | Range                 | Default                     | Notes                         |
|------------------------------|-----------------------|-----------------------------|-------------------------------|
| Monitor Only Setting         | False/True            | False                       | Refer to Section 1.2          |
| Cell Overvoltage             | 0...4.5               | 4 V                         | Refer to Section 1.2          |
| Cell Undervoltage            | 0...4.5               | 2 V                         | Refer to Section 1.2          |
| VPS Overvoltage              | VPS Undervoltage...90 | 80 V                        | Refer to Section 1.2          |
| VPS Undervoltage             | 0...VPS Overvoltage   | 10 V                        | Refer to Section 1.2          |
| Shutdown Temperature         | 0...150               | 100°C                       | Refer to Section 1.2          |
| Discharge Rx Timeout Setting | Drop List             | Automated Discharge Control | Refer to Section 1.2, Table 1 |
| Open Wire Check Period       | 0...60                | 5 seconds                   | Refer to Section 1.2          |
| Block Empty DM1 Messages     | False/True            | True                        | Refer to Section 1.2          |

**Table 9 – Default Cell Group Input Setpoints**

### 3.3. Cell Input Setpoints

The Cell Input function block is defined in Section 1.3. Please refer there for detailed information about how all these setpoints are used.

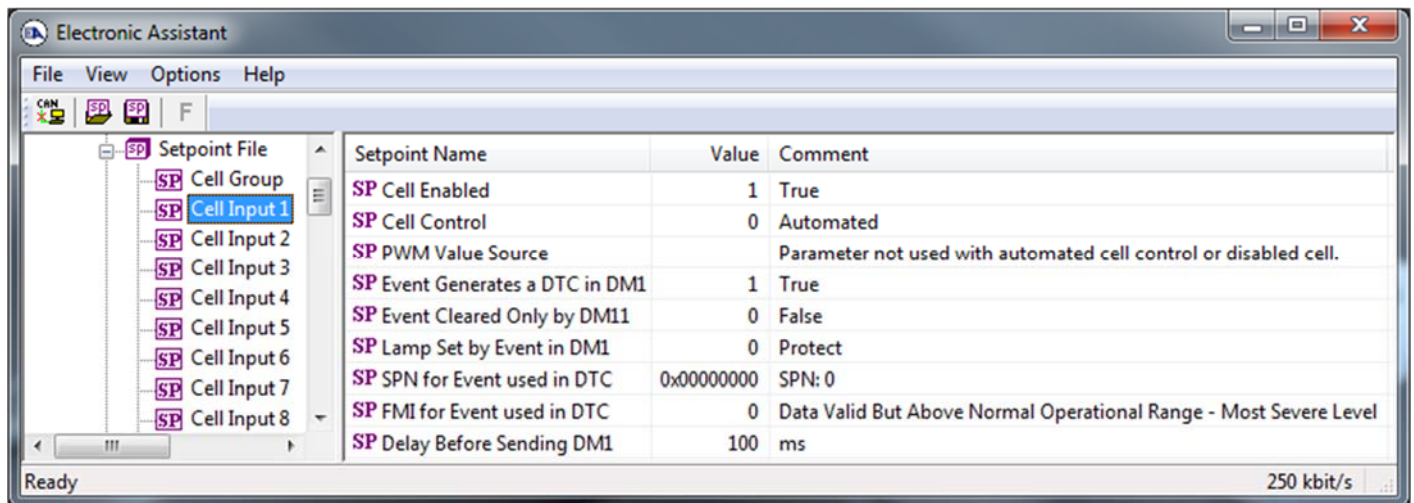

**Screen Capture of Default Cell Input Setpoints**

| Name                         | Range      | Default                | Notes                         |
|------------------------------|------------|------------------------|-------------------------------|
| Cell Enabled                 | False/True | True                   | Refer to Section 1.3          |
| Cell Control                 | Drop List  | Automated              | Refer to Section 1.3, Table 3 |
| PWM Value Source             | Drop List  | Depends on Cell Number | Refer to Section 1.3          |
| Event Generates a DTC in DM1 | False/True | True                   | Refer to Section 1.3          |
| Event Only Cleared by DM11   | False/True | False                  | Refer to Section 1.4          |
| Lamp Set by Event in DM1     | Drop List  | 0                      | Refer to Section 1.4          |
| SPN for Event used in DTC    | 0...524287 | 0                      | Refer to Section 1.4          |
| FMI for Event used in DTC    | Drop List  | 0                      | Refer to Section 1.4, Table 4 |
| Delay Before Sending DM1     | 0...60000  | 100                    | Refer to Section 1.4          |

Table 10 – Default Cell Input Setpoints

### 3.4. Diagnostic Input Setpoints

The Diagnostic Input function block is defined in Section 1.4. Please refer to that section for detailed information about how all these setpoints are used.

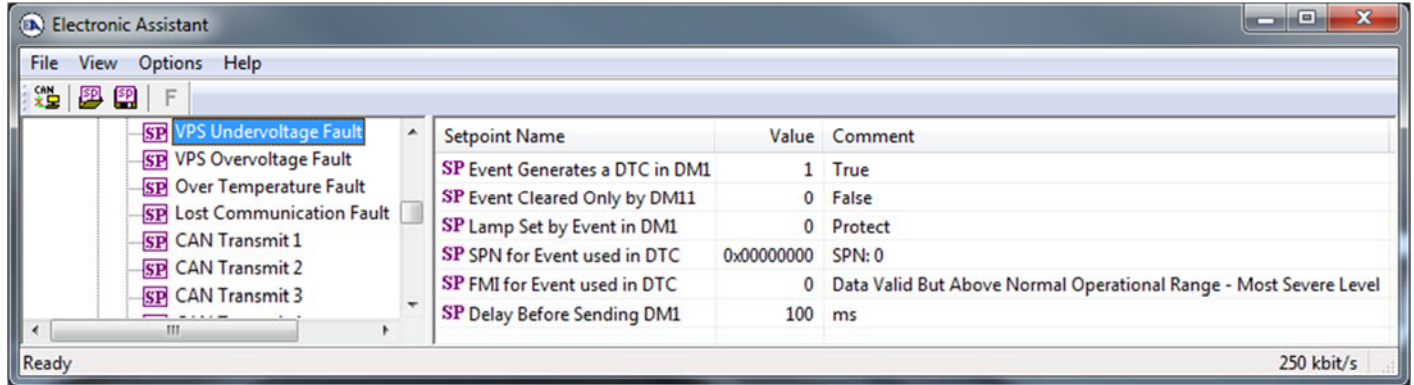

Screen Capture of Diagnostic Input Setpoints

| Name                         | Range      | Default | Notes                         |
|------------------------------|------------|---------|-------------------------------|
| Event Generates a DTC in DM1 | False/True | True    | Refer to Section 1.4          |
| Event Only Cleared by DM11   | False/True | False   | Refer to Section 1.4          |
| Lamp Set by Event in DM1     | Drop List  | 0       | Refer to Section 1.4          |
| SPN for Event used in DTC    | 0...524287 | 0       | Refer to Section 1.4          |
| FMI for Event used in DTC    | Drop List  | 0       | Refer to Section 1.4, Table 4 |
| Delay Before Sending DM1     | 0...60000  | 100     | Refer to Section 1.4          |

Table 11 – Default Diagnostic Input Setpoints

### 3.5. CAN Transmit Setpoints

The CAN Transmit function block is defined in Section 1.5. Please refer to that section for detailed information about how all these setpoints are used.

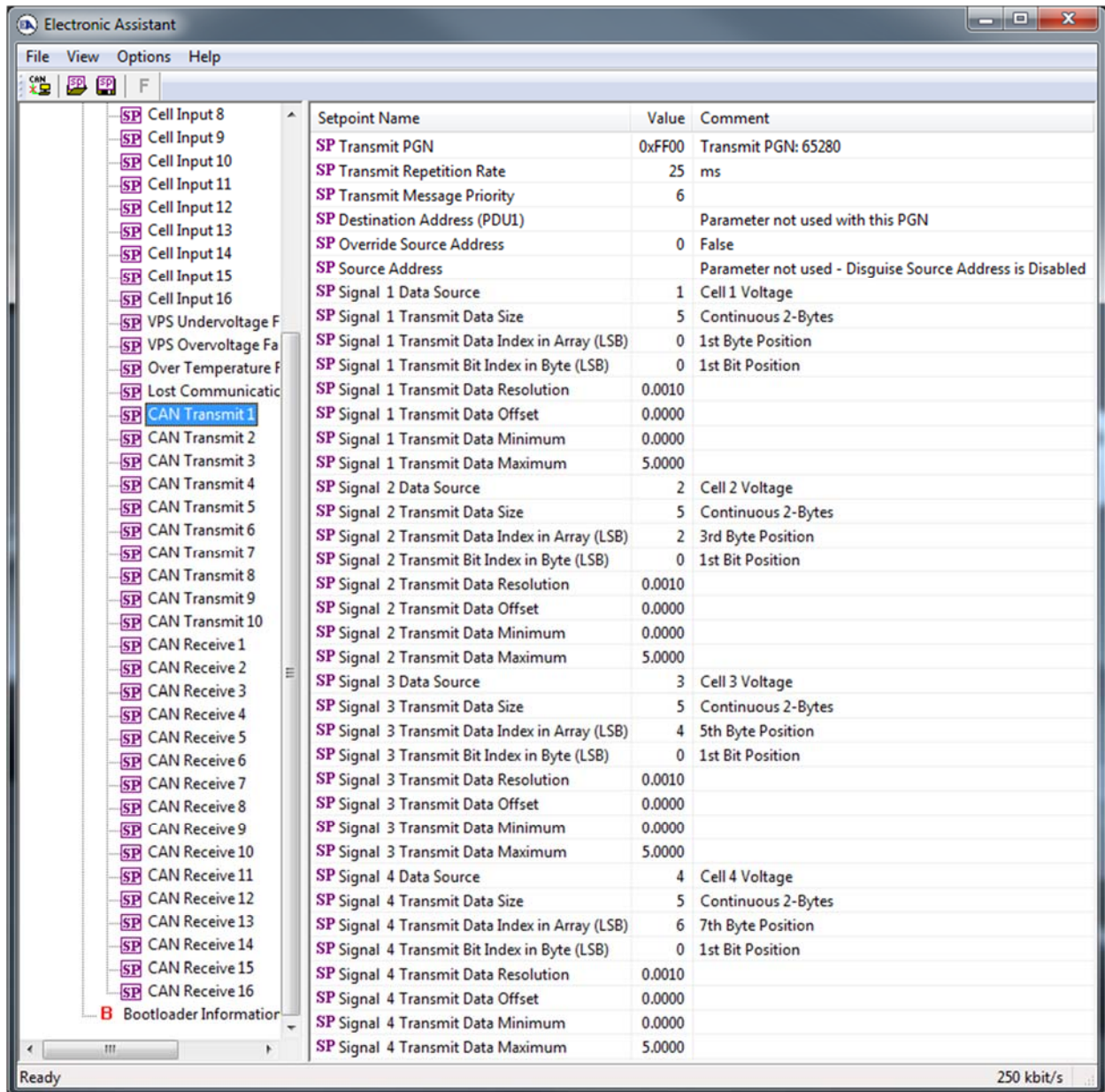

**Screen Capture of CAN Transmit Setpoints**

| Name                        | Range      | Default                  | Notes                         |
|-----------------------------|------------|--------------------------|-------------------------------|
| Transmit PGN                | 0..65535   | 65280 (\$FF00)           | Refer to Section 1.5          |
| Transmit Repetition Rate    | 0..60,000  | 0                        | Refer to Section 1.5          |
| Transmit Message Priority   | 0..7       | 6                        | Refer to Section 1.5          |
| Destination Address (PDU1)  | 0..255     | 254                      | Refer to Section 1.5          |
| Override Source Address     | False/True | False                    | Refer to Section 1.5          |
| Source Address              | 0..255     | 0                        | Refer to Section 1.5          |
| Signal x Data Source        | Drop List  | Depends on signal number | Refer to Section 1.5, Table 5 |
| Signal x Transmit Data Size | Drop List  | Continuous 2-Byte        | Refer to Section 1.5          |

|   |                                     |  |                      |
|---|-------------------------------------|--|----------------------|
| Signal x Transmit Data Index in Array (LSB) | 0 to 8-DataSize                     | Depends on signal number                                 | Refer to Section 1.5 |
| Signal x Transmit Bit Index in Byte (LSB)   | 0 to 8-DataSize                     | 0  | Refer to Section 1.5 |
| Signal x Transmit Data Resolution           | -10 <sup>6</sup> to 10 <sup>6</sup> | 0.001 for Cell Voltages,<br>0.01 for other signals       | Refer to Section 1.5 |
| Signal x Transmit Data Offset               | -10 <sup>4</sup> to 10 <sup>4</sup> | -45 for Temperature Shutdown,<br>0 for all other signals | Refer to Section 1.5 |
| Signal x Transmit Data Minimum              | -0xFFFFFFFF...DataMax               | 255  | Refer to Section 1.5 |
| Signal x Transmit Data Maximum              | DataMin...0xFFFFFFFF                | 0  | Refer to Section 1.5 |

**Table 12 – Default CAN Transmit Setpoints**

### 3.6. CAN Receive Setpoints

The CAN Receive function block is defined in Section 1.6. Please refer to that section for detailed information about how all these setpoints are used.

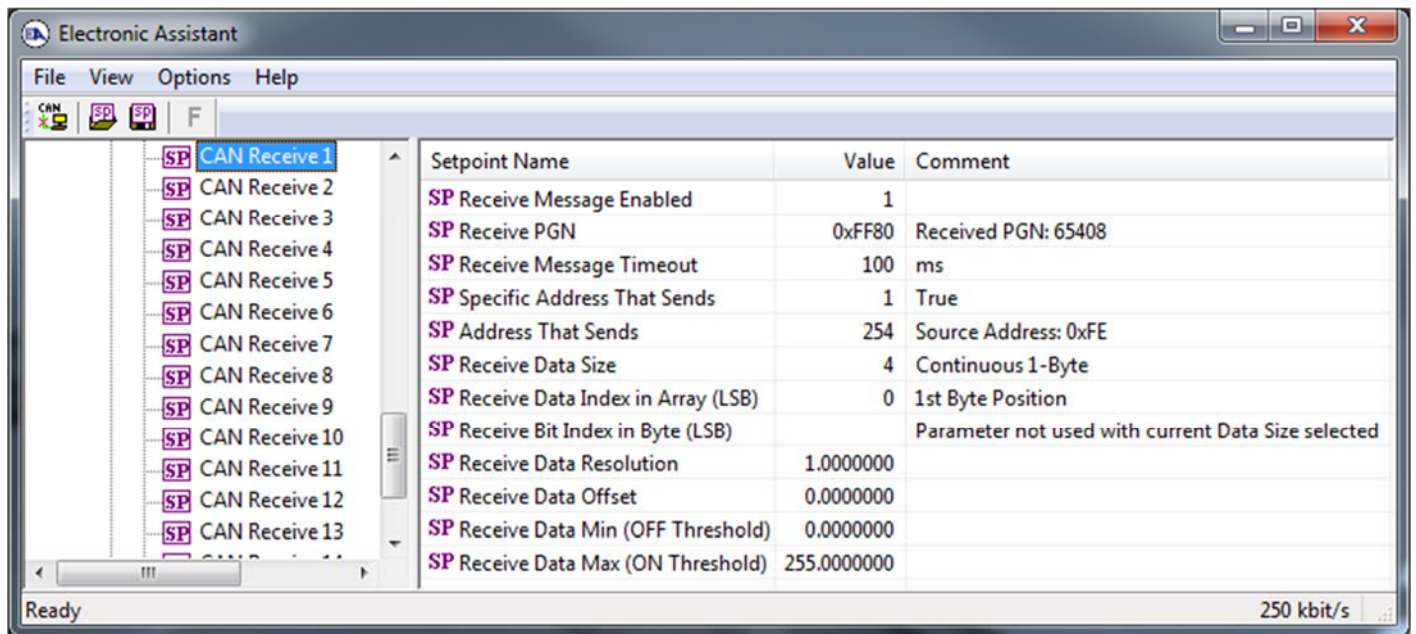

**Screen Capture of CAN Receive Setpoints**

| Name                        | Range      | Default           | Notes                |
|-----------------------------|------------|-------------------|----------------------|
| Receive Message Enable      | False/True | True              | Refer to Section 1.6 |
| Receive PGN                 | 0...65535  | 65408 (\$FF80)    | Refer to Section 1.6 |
| Receive Message Timeout     | 0...60000  | 100               | Refer to Section 1.6 |
| Specific Address That Sends | False/True | True              | Refer to Section 1.6 |
| Address That Sends          | 0...255    | 254 (\$FE)        | Refer to Section 1.6 |
| Receive Data Size           | Drop List  | Continuous 1-Byte | Refer to Section 1.6 |

|                                   |                                     |        |                      |
|-----------------------------------|-------------------------------------|--------|----------------------|
| Receive Data Index in Array (LSB) | 0...8-DataSize                      | Byte 1 | Refer to Section 1.6 |
| Receive Bit Index in Byte (LSB)   | 0...8-DataSize                      | 0      | Refer to Section 1.6 |
| Receive Data Resolution           | -10 <sup>6</sup> to 10 <sup>6</sup> | 1      | Refer to Section 1.6 |
| Receive Data Offset               | -10 <sup>4</sup> to 10 <sup>4</sup> | 0      | Refer to Section 1.6 |
| Receive Data Minimum              | -0xFFFFFFFF...DataMax               | 0      | Refer to Section 1.6 |

**Table 13 – Default CAN Receive Setpoints**

#### 4. REFLASHING OVER CAN WITH EA BOOTLOADER

The AX0320x0 can be upgraded with new application firmware using the **Bootloader Information** section. This section details the simple step-by-step instructions to upload new firmware provided by Axiomatic onto the unit via CAN, without requiring it to be disconnected from the J1939 network.

1. When EA first connects to the ECU, the **Bootloader Information** section will display the following information.

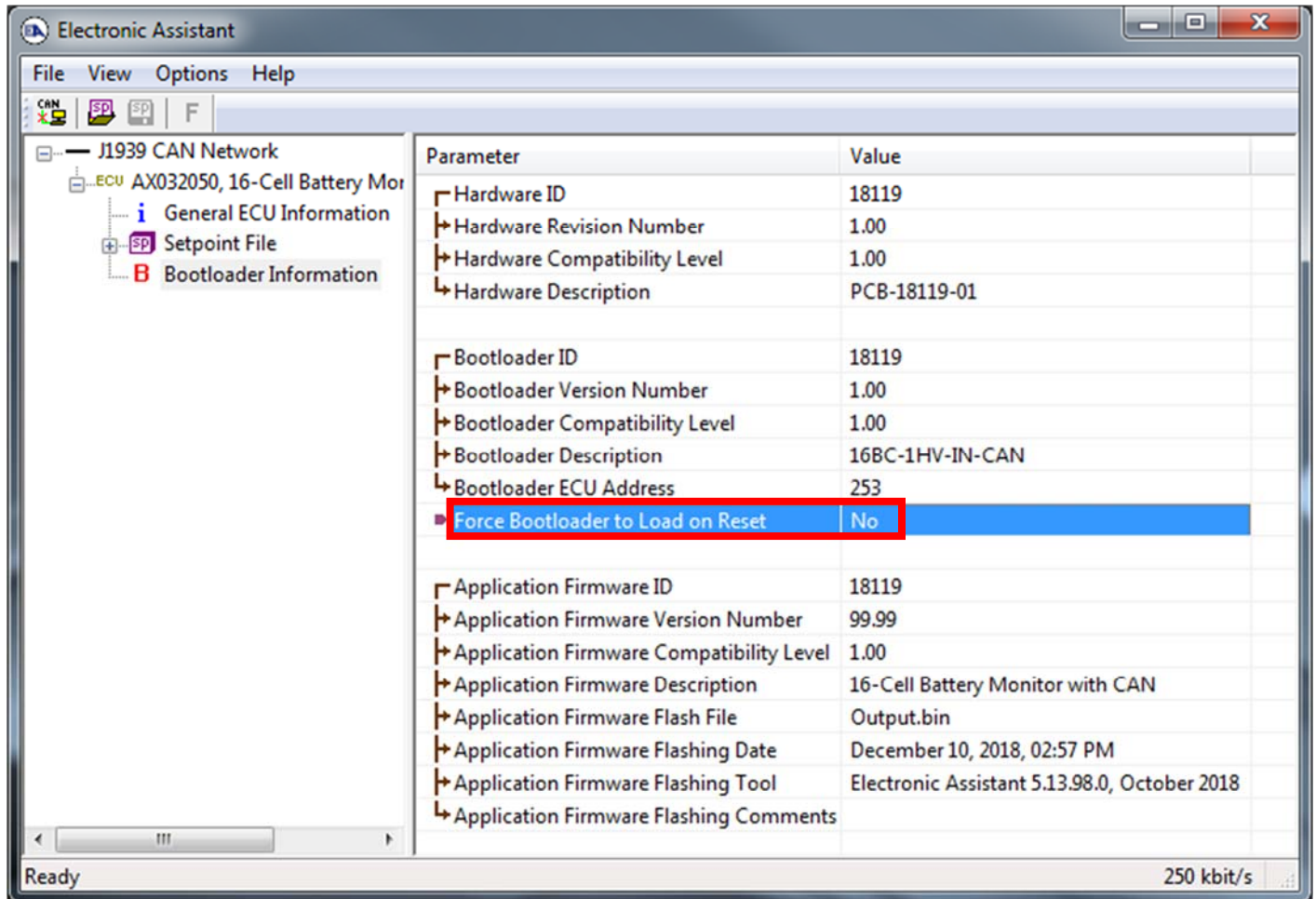

2. To use the bootloader to upgrade the firmware running on the ECU, change the variable **“Force Bootloader to Load on Reset”** to **Yes**.

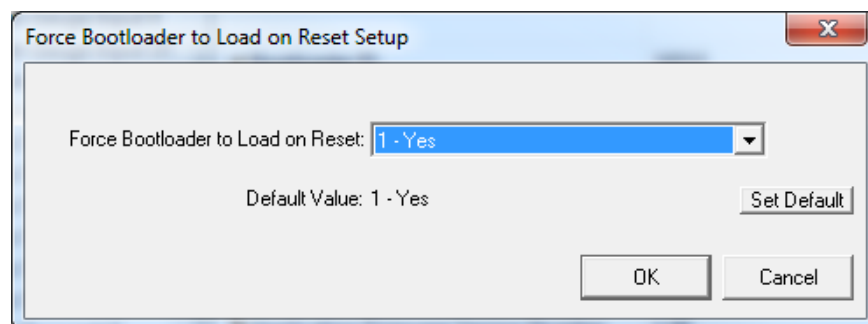

3. When the prompt box asks if you want to reset the ECU, select **Yes**.

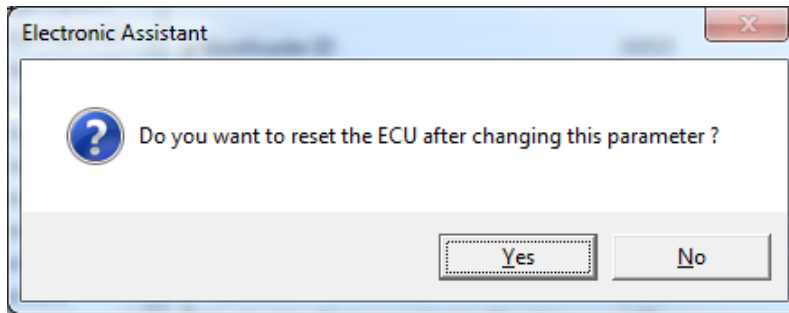

- Upon reset, the ECU will no longer show up on the J1939 network as an AX0320x0 but rather as **J1939 Bootloader #1**.

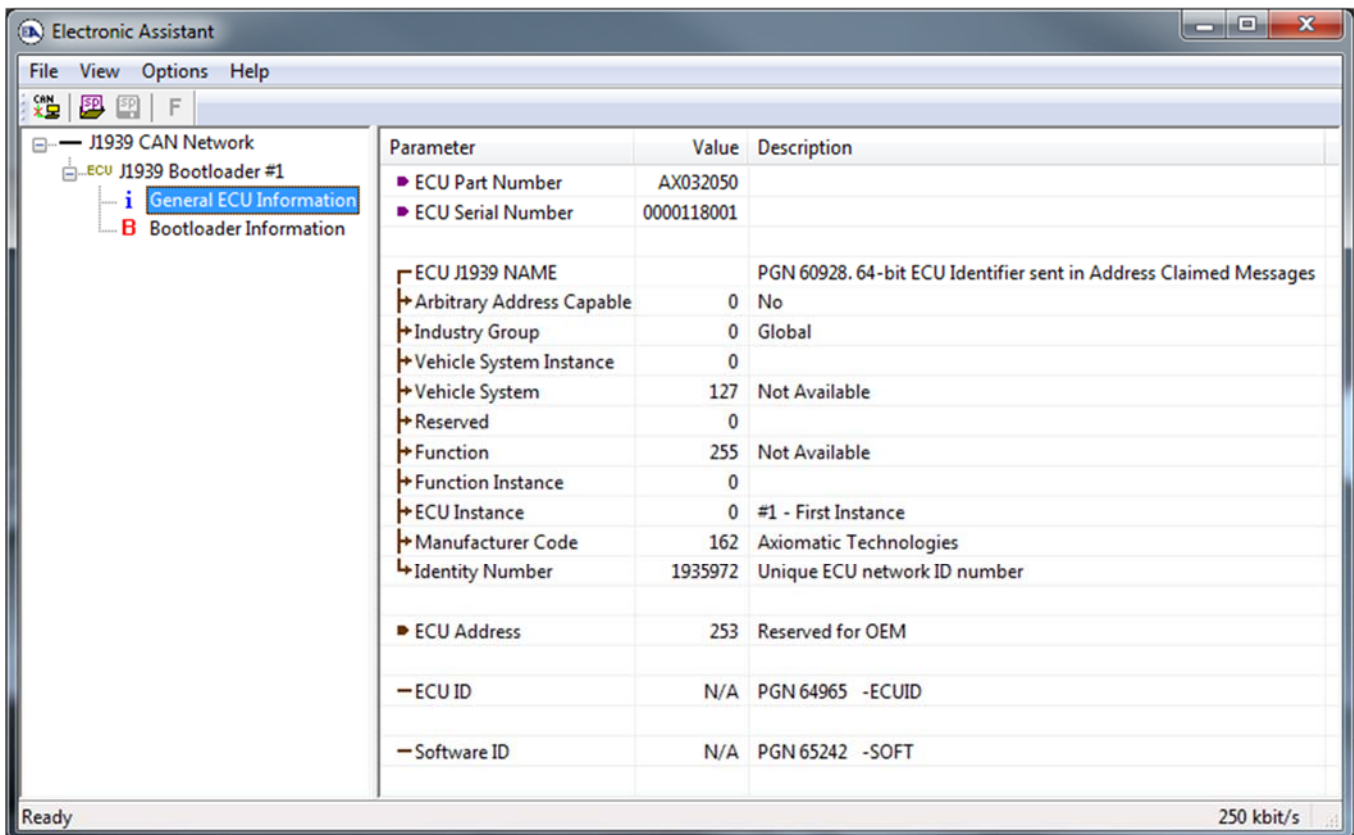
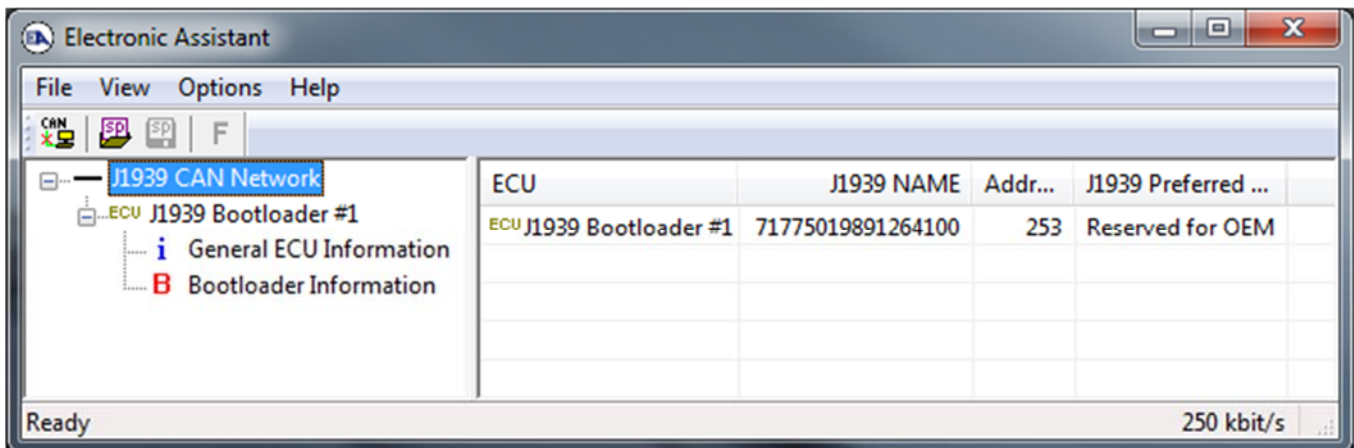

Note that the bootloader is **NOT** Arbitrary Address Capable. This means that if you want to have multiple bootloaders running simultaneously (not recommended) you would have to manually change the address for each one before activating the next, or there will be address conflicts, and only one ECU would show up as the bootloader. Once the ‘active’ bootloader returns to regular functionality, the other ECU(s) would have to be power cycled to re-activate the bootloader feature.

- When the **Bootloader Information** section is selected, the same information is shown as when it was running the AX0320x0 firmware, but in this case the **Flashing** feature has been enabled.

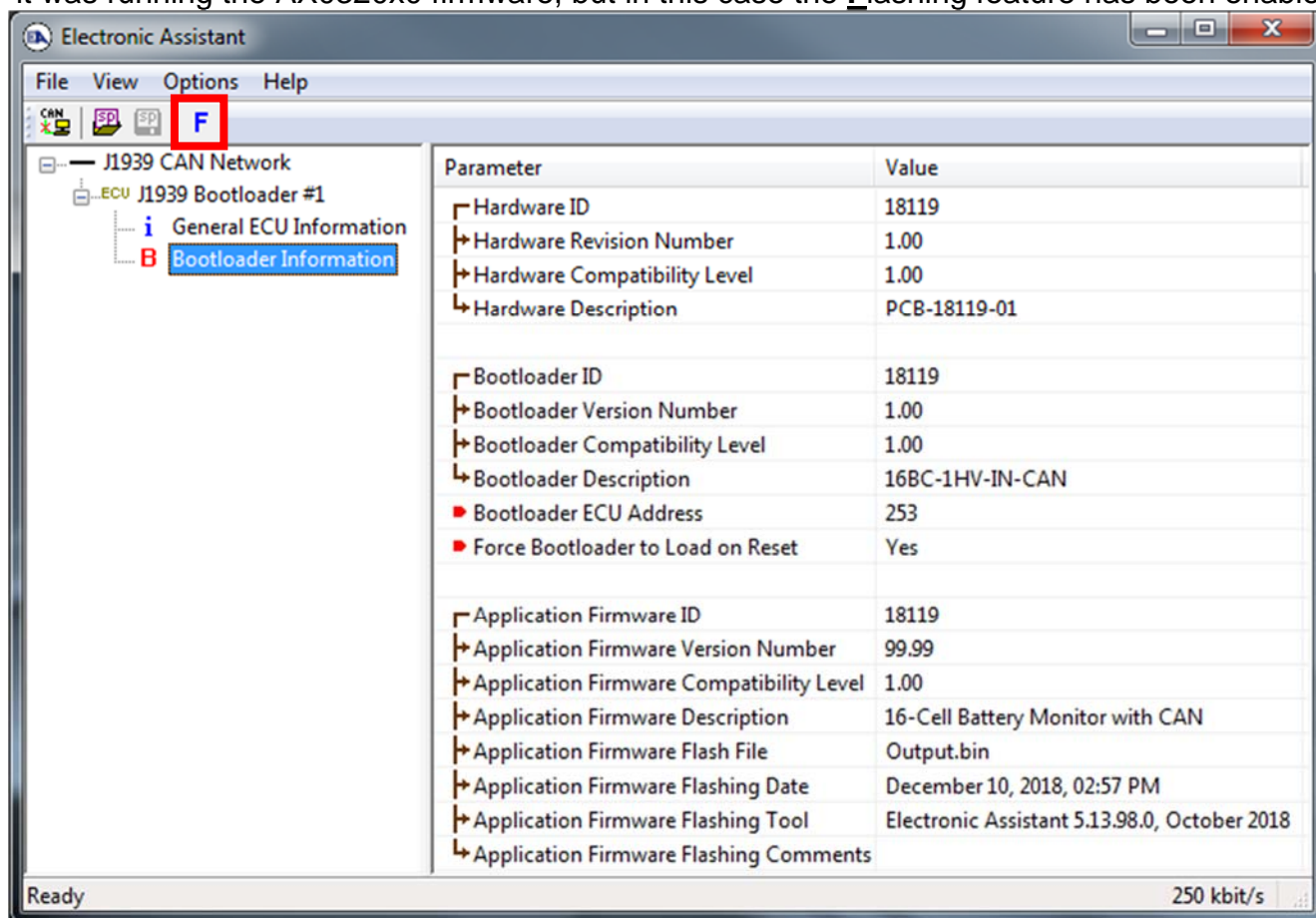

- Select the **Flashing** button and navigate to where you had saved the **AF-18009-x.yy.bin** or **AF-18119-x.yy.bin** file sent from Axiomatic. (Note: only binary (.bin) files can be flashed using the EA tool)
- Once the Flash Application Firmware window opens, you can enter comments such as “Firmware upgraded by [Name]” if you so desire. This is not required, and you can leave the field blank if you do not want to use it.

Note: You do not have to date/time-stamp the file, as this is done automatically by the EA tool when you upload the new firmware.

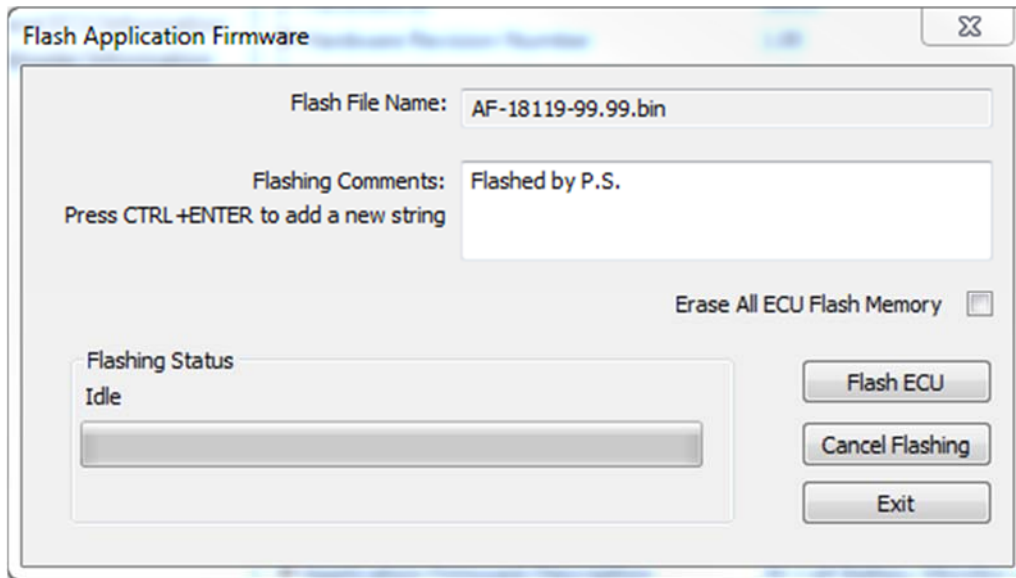

**WARNING:** Do not check the “Erase All ECU Flash Memory” box unless instructed to do so by your Axiomatic contact. Selecting this will erase ALL data stored in non-volatile flash. It will also erase any configuration of the setpoints that might have been done to the ECU and reset all setpoints to their factory defaults. By leaving this box unchecked, none of the setpoints will be changed when the new firmware is uploaded.

8. A progress bar will show how much of the firmware has been sent as the upload progresses. The more traffic there is on the J1939 network, the longer the upload process will take.

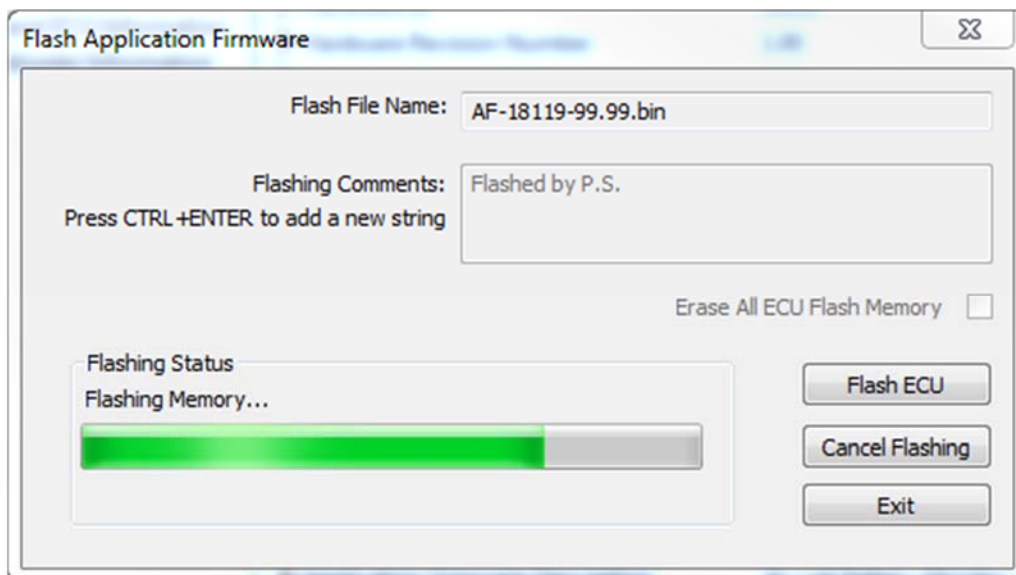

9. Once the firmware has finished uploading, a message will popup indicating the successful operation. If you select to reset the ECU, the new version of the AX0320x0 application will start running, and the ECU will be identified as such by EA. Otherwise, the next time the ECU is power-cycled, the AX0320x0 application will run rather than the bootloader function.

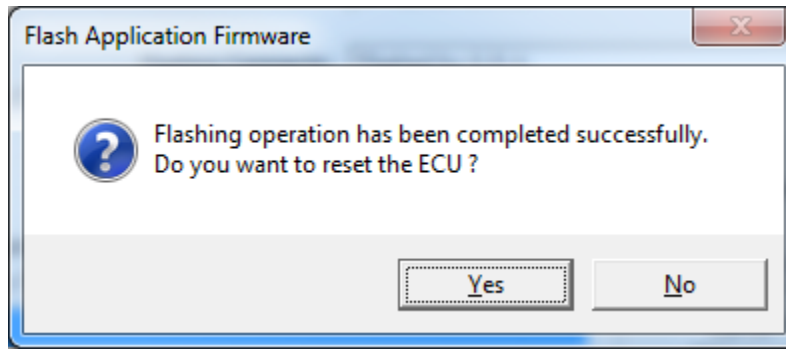

Note: If at any time during the upload the process is interrupted, the data is corrupted (bad checksum) or for any other reason the new firmware is not correct, i.e. bootloader detects that the file loaded was not designed to run on the hardware platform, the bad or corrupted application will not run. Rather, when the ECU is reset or power-cycled the **J1939 Bootloader** will continue to be the default application until valid firmware has been successfully uploaded into the unit.

## 5. INSTALLATION INSTRUCTIONS

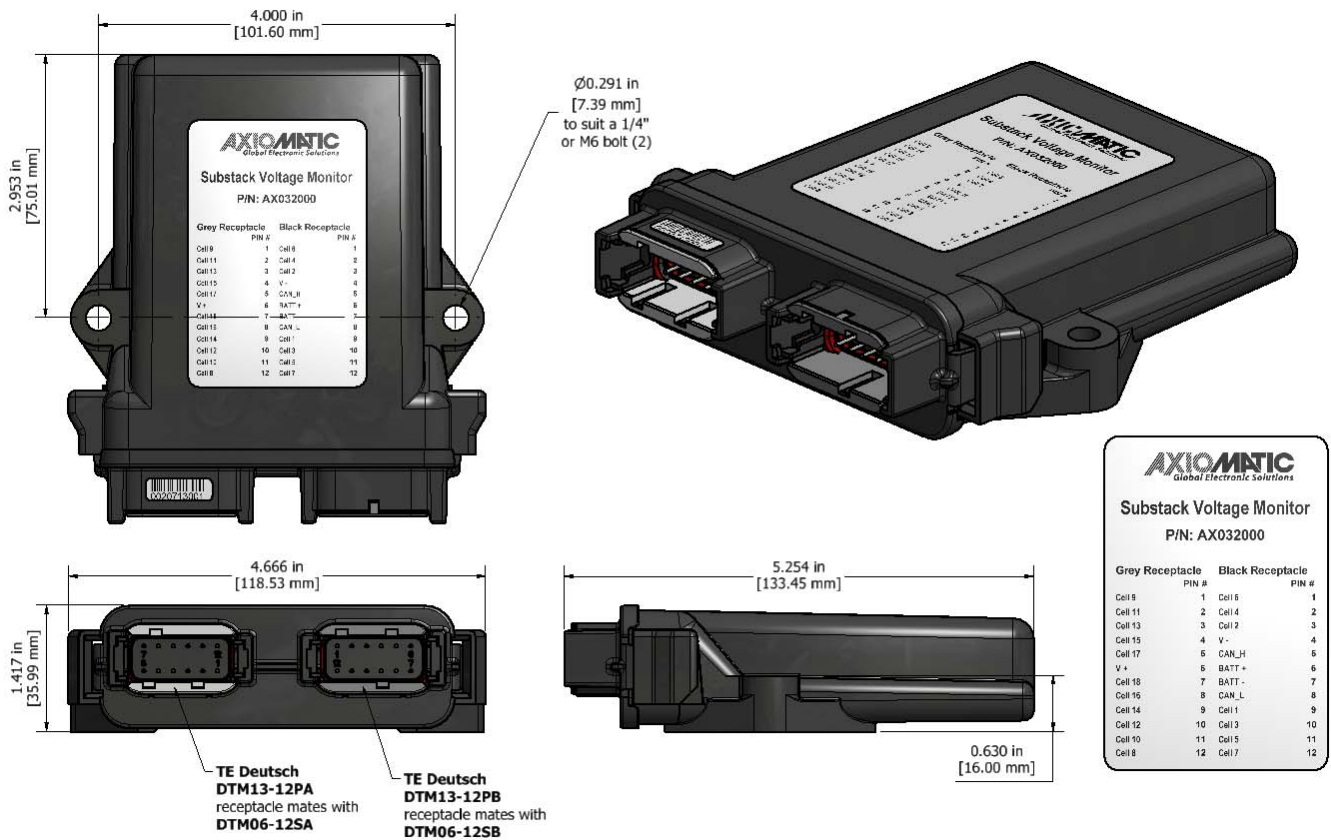
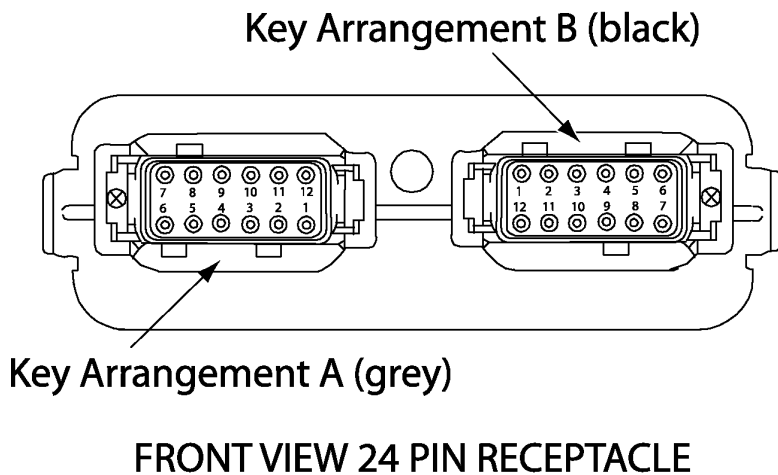

Figure 1.0 - Dimensional Drawing – Model AX032000 is shown.

### Electrical Connections

Deutsch DTM series 24 pin receptacle (DTM13-12PA-12PB-R008)  
Mating plug: Deutsch DTM06-12SA and DTM06-12SB  
with 2 wedgelocks (WM12S) and 24 contacts (0462-201-20141).  
20 AWG wire is recommended for use with contacts 0462-201-20141.



### 18-Cell Connector Pinout

| Grey Connector |         | Black Connector |        |
|----------------|---------|-----------------|--------|
| 1              | Cell 9  | 1               | Cell 6 |
| 2              | Cell 11 | 2               | Cell 4 |
| 3              | Cell 13 | 3               | Cell 2 |
| 4              | Cell 15 | 4               | V -    |
| 5              | Cell 17 | 5               | CAN_H  |
| 6              | V +     | 6               | BATT + |
| 7              | Cell 18 | 7               | BATT - |
| 8              | Cell 16 | 8               | CAN_L  |
| 9              | Cell 14 | 9               | Cell 1 |
| 10             | Cell 12 | 10              | Cell 3 |
| 11             | Cell 10 | 11              | Cell 5 |
| 12             | Cell 8  | 12              | Cell 7 |

### 16-Cell Connector Pinout

| Grey Connector |          | Black Connector |          |
|----------------|----------|-----------------|----------|
| 1              | Cell 8   | 1               | Cell 5   |
| 2              | Cell 10  | 2               | Cell 3   |
| 3              | Cell 12  | 3               | Not Used |
| 4              | Cell 14  | 4               | V -      |
| 5              | Cell 16  | 5               | CAN_H    |
| 6              | V +      | 6               | BATT +   |
| 7              | Not Used | 7               | BATT -   |
| 8              | Cell 15  | 8               | CAN_L    |
| 9              | Cell 13  | 9               | Cell 1   |
| 10             | Cell 11  | 10              | Cell 2   |
| 11             | Cell 9   | 11              | Cell 4   |
| 12             | Cell 7   | 12              | Cell 6   |

## 6. TECHNICAL SPECIFICATIONS

### 6.1. Input Specifications

|                              |   |
|------------------------------|---|
| Power Supply Input - Nominal | 12V, 24Vdc nominal (6...90Vdc power supply range)   |
| Isolation                    | Isolated power supply up to 1,000 V   |
| Protection                   | Surge and reverse polarity protection are provided.   |
| All Inputs                   | <p>18 Differential Battery Cell Inputs<br/>           19 Input Pins are provided to permit multiple units to be connected in series.<br/>           16-bit Sigma-delta ADC with third order noise programmable digital filter<br/>           Cell measurement range 0-5Vdc<br/>           Scan rate is programmable from 1 to 200 milliseconds for all 18 cells.<br/>           Total measurement error is 2.2mV maximum.</p> <p>Passive cell balancing up to 1A (max.) with individual programmable pulse width modulation duty cycle control for each cell.</p> <p>Suitable for most battery chemistries.</p> |
| Battery Stack Voltage Input  | <p>1 0-90Vdc voltage input measurement<br/>           12-bit ADC<br/>           0.5% accuracy</p>   |

### 6.2. General Specifications

|                           |   |
|---------------------------|---|
| Microprocessor            | STM32F405RG   |
| Control Logic             | Standard control logic  |
| User Interface (PC-based) | <p>Electronic Assistant® for <i>Windows</i> operating systems<br/>           It comes with a royalty-free license for use.<br/>           The Electronic Assistant® requires an Axiomatic USB-CAN converter to link the device's CAN port to a <i>Windows</i>-based PC. This is included in the Configuration KIT P/N AX070502.</p> |
| CAN Communications        | <p>1 CAN port (SAE J1939)<br/>           Isolated up to 1,000 V</p>   |
| Quiescent Current Draw    | <p>23 mA @ 24V<br/>           46 mA @ 12V</p>   |
| Compliance                | <p>RoHS Directive<br/>           Pending CE marking for EMC Directive</p>   |
| Vibration                 | <p>Pending<br/>           Random Vibration: 7.7 Grms peak<br/>           Sinusoidal Component: 10 g peak<br/>           Based on MIL-STD-202G, Methods 204G and 214A</p>  |
| Shock                     | <p>Pending<br/>           50 g half sine pulse, 6 x 6ms per axis<br/>           Based on MIL-STD-202G, Method 213B, Test Condition A</p>  |
| Network Termination       | <p>It is necessary to terminate the network with external termination resistors. The resistors are 120 Ohm, 0.25W minimum, metal film or similar type. They should be placed between CAN_H and CAN_L terminals at both ends of the network.</p>   |
| Operating Conditions      | -40 to 85 °C (-40 to 185 °F)  |
| Protection                | IP67, PCB is conformal coated and protected by the housing.   |
| Weight                    | 0.50 lb. (0.23 kg) (to be confirmed)  |
| Enclosure and Dimensions  | <p>High Temperature Nylon housing - Deutsch IPD PCB Enclosure (EEC-325X4B)<br/>           4.66 x 5.25 x 1.42 inches 118.53 x 133.45 x 35.99 mm<br/>           (W x L x H excluding mating plugs)</p>  |

## 7. VERSION HISTORY

---

| <b>Version</b> | <b>Date</b>       | <b>Author</b>   | <b>Modifications</b>                    |
|----------------|-------------------|-----------------|---|
| 1              | December 12, 2018 | Peter Sotirakos | Initial Draft                           |
| -              | January 31, 2019  | Amanda Wilkins  | Marketing Review, Unit Weight           |
| -              | January 31, 2019  | Peter Sotirakos | Added Installation Instructions         |
| 2              | February 15, 2019 | Peter Sotirakos | Added changes for firmware version 2.00 |



## OUR PRODUCTS

Actuator Controls  
Battery Chargers  
CAN bus Controls, Gateways  
CAN/Wifi, CAN/Bluetooth  
CAN/Ethernet  
Current Converters  
DC/DC Power Converters  
DC Voltage/Current Signal Converters  
Engine Temperature Scanners  
Ethernet/CAN Converters  
Fan Drive Controllers  
Hydraulic Valve Controllers  
I/O Controls  
LVDT Simulators  
Machine Controls  
Motor Controls  
PID Controls  
Position Sensors, Angle Measurement Inclinometers, Gyroscopes  
Power Supplies  
PWM Signal Converters/Isolators  
Resolver Signal Conditioners  
Service Tools  
Signal Conditioners  
Strain Gauge CAN Controls  
Surge Suppressors

## OUR COMPANY

Axiomatic provides electronic machine controls, components, and systems to the off-highway, commercial vehicle, electric vehicle, power generator set, material handling, renewable energy and industrial OEM markets.

We provide efficient, innovative solutions that focus on adding value for our customers.

We emphasize service and partnership with our customers, suppliers, and employees to build long term relationships and mutual trust.

## QUALITY DESIGN AND MANUFACTURING

Axiomatic is an ISO 9001:2015 registered facility.

## SERVICE

All products to be returned to Axiomatic require a Return Materials Authorization Number (RMA#).

Please provide the following information when requesting an RMA number:

- Serial number, part number
- Axiomatic invoice number and date
- Hours of operation, description of problem
- Wiring set up diagram, application
- Other comments as needed

When preparing the return shipping paperwork, please note the following. The commercial invoice for customs (and packing slip) should state the harmonized international HS (tariff code), valuation and return goods terminology, as shown in italics below. The value of the units on the commercial invoice should be identical to their purchase price.

*Goods Made In Canada (or Finland)  
Returned Goods for Warranty Evaluation, HS: 9813.00  
Valuation Identical Goods  
Axiomatic RMA#*

## WARRANTY, APPLICATION APPROVALS/LIMITATIONS

Axiomatic Technologies Corporation reserves the right to make corrections, modifications, enhancements, improvements, and other changes to its products and services at any time and to discontinue any product or service without notice. Customers should obtain the latest relevant information before placing orders and should verify that such information is current and complete. Users should satisfy themselves that the product is suitable for use in the intended application. All our products carry a limited warranty against defects in material and workmanship. Please refer to our Warranty, Application Approvals/Limitations and Return Materials Process as described on [www.axiomatic.com/service.html](http://www.axiomatic.com/service.html).

## CONTACTS

**Axiomatic Technologies Corporation**  
5915 Wallace Street  
Mississauga, ON  
CANADA L4Z 1Z8  
TEL: +1 905 602 9270  
FAX: +1 905 602 9279  
[www.axiomatic.com](http://www.axiomatic.com)

**Axiomatic Technologies Oy**  
Höytämöntie 6  
33880 Lempäälä  
FINLAND  
TEL: +358 103 375 750  
FAX: +358 3 3595 660  
[www.axiomatic.fi](http://www.axiomatic.fi)