

USER MANUAL

2 Bipolar, 8 Universal Signal Input Controller, CAN (SAE J1939), Ethernet (Modbus TCP/IP), Two +5V References, DIN Rail Mount

P/N: AX032100

In Europe:
Axiomatic Technologies Oy
Höytämöntie 6
33880 Lempäälä - Finland
Tel. +358 103 375 750
Fax. +358 3 3595 660
www.axiomatic.fi

In North America:
Axiomatic Technologies Corporation
5915 Wallace Street
Mississauga, ON Canada L4Z 1Z8
Tel. 1 905 602 9270
Fax. 1 905 602 9279
www.axiomatic.com

ACRONYMS

ARP	Address Resolution Protocol
ASCII	American Standard Code for Information Interchange
AWG	American wire gauge
CAN	Controller Area Network
CE	Conformité Européenne (European Conformity)
CMOS	Complementary metal-oxide-semiconductor
DC	Direct Current
DIN	German Institute for Standardization
DM	Diagnostic message. Defined in J1939/73 standard
EA	Electronic Assistant [®] . PC application software from Axiomatic
ECU	Electronic control unit
EEPROM	Electrically Erasable Programmable Read-Only Memory
EMI	Electromagnetic Interference
EN	European Standard
GPL	General Public License
ICMP	Internet Control Message Protocol
ID	Identifier
IEC	International Electrotechnical Commission
IEEE	Institute of Electrical and Electronics Engineers
IP	Internet Protocol or Ingress Protection (for housing)
ISO	International Organization for Standardization
LAN	Local Area Network
LED	Light-emitting diode
LoZ	Low resistance
LSB	Less Significant Byte
MAC	Media Access Control (address)
MDIX	Medium Dependent Interface Crossover (MDI-X)
PC	Personal Computer
PGN	Parameter Group Number. Defined in J1939/73 standard
PHY	Physical Layer Transceiver (Ethernet chip)
P/N	Part Number
PWM	Pulse-width modulation
RoHS	Restriction of Hazardous Substances
RTOS	Real-Time Operating System
SAE J1939	CAN-based higher-level protocol designed and supported by the Society of automobile Engineers (SAE)
S/N	Serial Number
TBD	To be determined
TCP	Transmission Control Protocol
UDP	User Datagram Protocol
UL	Underwriters Laboratories (safety organization)
USB	Universal Serial Bus
VDC	Volt Direct Current
UTP	Unshielded twisted pair

TABLE OF CONTENTS

1	INTRODUCTION.....	5
2	CONTROLLER DESCRIPTION	6
2.1	Hardware Block Diagram	6
2.2	Software Organization	7
2.3	CAN Interface	7
2.3.1	CAN Baud Rate	8
2.3.2	J1939 Name and Address	8
2.3.3	Slew Rate Control.....	9
2.3.4	Network Bus Terminating Resistors.....	9
2.4	Modbus TCP Interface	9
2.5	Discovery Protocol.....	10
2.6	LED Indicators	11
2.6.1	Ethernet LED	11
2.6.2	CAN/System LED	11
2.7	Default Settings.....	11
3	CONTROLLER LOGICAL STRUCTURE	12
3.1	Function Block Signals.....	13
3.2	Output Signal Sources	13
3.3	Bipolar Inputs.....	14
3.3.1	Voltage Measurements	16
3.3.2	Current Measurements	17
3.3.3	Discrete Voltage Level.....	17
3.3.4	Frequency and PWM	17
3.3.4.1	Special Conditions.....	18
3.4	Universal Inputs	19
3.4.1	Voltage Measurements	21
3.4.2	Current Measurements	22
3.4.3	Resistance Measurements	22
3.4.4	Discrete Voltage Level.....	23
3.4.5	Frequency and PWM	23
3.4.5.1	Special Conditions.....	25
3.5	Binary Functions	26
3.6	Global Parameters	28
3.7	J1939 Network.....	29
3.7.1	ECU Network Parameters.....	29
3.7.2	CAN Network Parameters.....	30
3.8	Ethernet	30
3.9	CAN Input Signals.....	31
3.10	CAN Output Messages	32
4	CONTROLLER CONFIGURATION.....	36
4.1	Modbus Configuration	36
4.2	CAN Configuration	36
4.3	Function blocks in EA	38
4.4	Setpoint File	39
4.5	Configuration Example.....	40
4.5.1	User Requirements.....	40

4.5.2	Configuration Steps	40
5	FLASHING NEW FIRMWARE	44
6	TECHNICAL SPECIFICATIONS	48
6.1	Power Supply.....	48
6.2	Bipolar Inputs.....	48
6.3	Universal Inputs	49
6.4	Voltage Reference Outputs.....	50
6.5	Ethernet Interface	50
6.6	CAN Interface	50
6.7	General Specifications	51
6.8	Enclosure.....	52
6.9	Electrical Connections	52
6.10	Installation.....	52
7	MODBUS ADDRESS MAP	53
8	THIRD-PARTY SOFTWARE LICENSE NOTICES.....	123
9	VERSION HISTORY	125

1 INTRODUCTION

The following user manual describes architecture, functionality, configuration parameters and flashing instructions for the 2 Bipolar, 8 Universal Signal Input Controller with SAE J1939 CAN and Modbus TCP/IP Ethernet communication links. It also contains controller technical specifications and installation instructions to help users build a custom solution on the base of this controller.

The user should check whether the application firmware installed in the controller is covered by this user manual. It can be done through CAN bus using Axiomatic Electronic Assistant® (EA) software or using Ethernet Modbus TCP/IP link.

The user manual is valid for application firmware with the same major version number as the user manual. For example, this user manual is valid for any converter application firmware V1.xx. Updates specific to the user manual are done by adding letters: A, B, ..., Z to the user manual version number.

It is assumed, that the user is familiar with Modbus and J1939 CAN groups of standards. The terminology from these standards is widely used in this manual.

2 CONTROLLER DESCRIPTION

The controller is designed to convert physical signals from bipolar and universal inputs into J1939 CAN signals and input register data for the Modbus TCP interface. The bipolar and universal inputs accept voltage, current, resistance (only universal inputs), frequency, PWM duty cycle, and discrete voltage levels. Two independent +5V reference voltage outputs can be used to power user equipment.

The J1939 CAN network can operate at standard 250 and 500 kbit/s and non-standard 667kbit/s and 1Mbit/s baud rates. The required baud rate is detected automatically upon connection to the CAN network.

The Modbus TCP/IP interface runs on a standard 10/100 Mbit/s Ethernet link providing up to 5 simultaneous client connections.

The controller can be configured through a set of configuration parameters over CAN or Ethernet interface to fit the user-specific application requirements.

2.1 Hardware Block Diagram

The controller contains 2 bipolar, 8 universal signal inputs, one CAN and one Ethernet port, two +5V reference voltage outputs, and a protected power supply. An embedded 32-bit microcontroller provides necessary processing power to the controller.

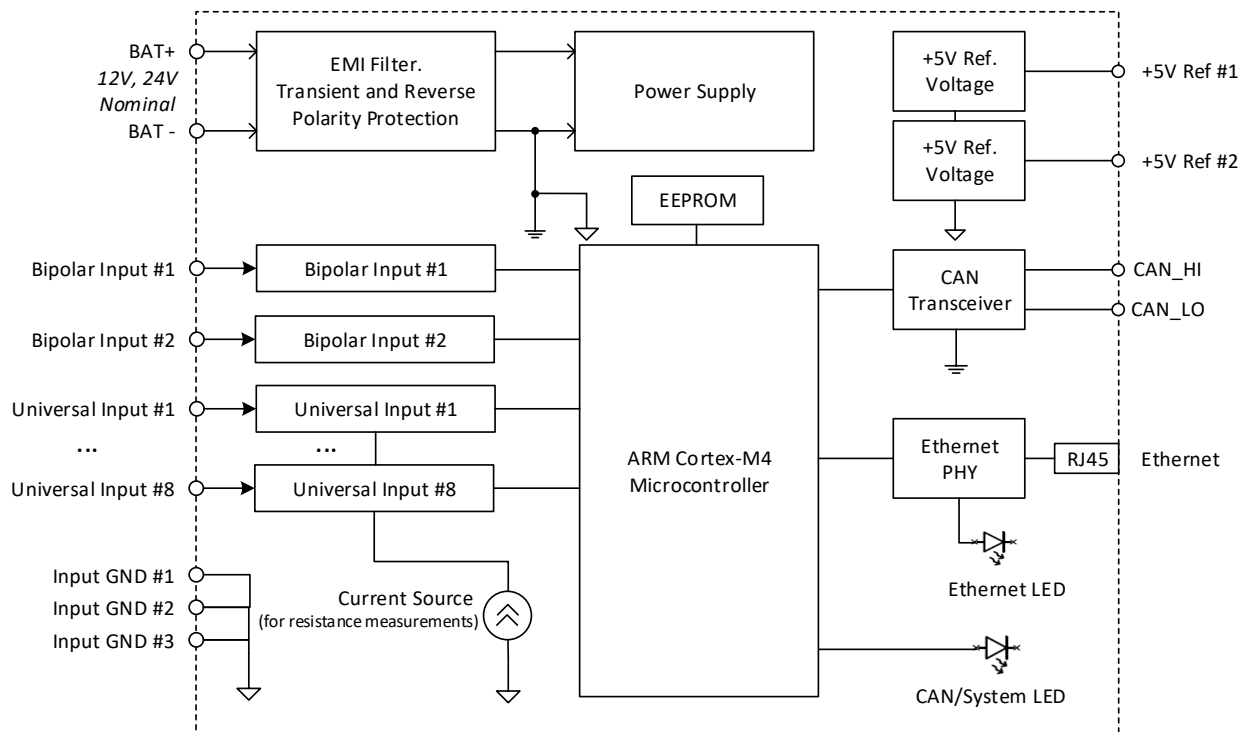

Figure 1. The Controller Hardware Block Diagram

The controller has a wide range of protection features including a transient and reverse polarity protection, see TECHNICAL SPECIFICATIONS section.

2.2 Software Organization

The controller belongs to a family of Axiomatic smart controllers with configurable internal architecture. This architecture allows building of a signal converting algorithm based on a set of predefined internal configurable function blocks without the need of a custom software.

The user can configure the controller internal structure and individual function blocks using PC-based Axiomatic Electronic Assistant® (EA) software through CAN interface, without disconnecting the converter from the user system. Alternatively, the user can configure the controller through the Modbus link.

The controller application firmware can be updated through CAN interface in the field using EA, see FLASHING NEW FIRMWARE section. Updating firmware over Modbus is currently not implemented.

2.3 CAN Interface

The CAN interface is compliant with Bosch CAN protocol specification, Rev.2.0, Part B, and the following SAE J1939 standards:

Table 1. CAN Standard Implementation

ISO/OSI Network Model Layer	J1939 Standard
Physical	J1939/11 – Physical Layer, 250K bit/s, Twisted Shielded Pair. Rev. SEP 2006. J1939/15 - Reduced Physical Layer, 250K bits/sec, Un-Shielded Twisted Pair (UTP). Rev. AUG 2008. J1939/14 - Physical Layer, 500 Kbps. Rev. OCT 2011. J1939/16 – Automatic Baud Rate Detection Process. Rev. NOV 2018.
Data Link	J1939/21 – Data Link Layer. Rev. DEC 2006 The controller supports Transport Protocol for Commanded Address messages (PGN 65240), ECU identification messages -ECUID (PGN 64965), and software identification messages -SOFT (PGN 65242). It also supports responses on PGN Requests (PGN 59904). Please note that the Proprietary A PGN (PGN 61184) is taken by Axiomatic Simple Proprietary Protocol and is not available for the user.
Network	J1939, Appendix B – Address and Identity Assignments. Rev. FEB 2010. J1939/81 – Network Management. Rev. MAR2017. The controller is an Arbitrary Address Capable ECU. It can dynamically change its network address in real-time to resolve an address conflict with other ECUs. The controller supports: Address Claimed Messages (PGN 60928), Requests for Address Claimed Messages (PGN 59904) and Commanded Address Messages (PGN 65240).
Transport	N/A in J1939.
Session	N/A in J1939.
Presentation	N/A in J1939.
Application	J1939/71 – Vehicle Application Layer. Rev. APR 2014 with J1939DA – Digital Annex. Rev. OCT 2014. The controller can receive and transmit application-specific PGNs. All application-specific PGNs are user-programmable.

ISO/OSI Network Model Layer	J1939 Standard
	J1939/73 – Application Layer – Diagnostics. Rev. FEB 2010 Memory access protocol (MAP) support. DM14, DM15, DM16 are used by EA to program configuration parameters. DM13 support is provided to temporarily suppress transmission of application-specific PGNs.

2.3.1 CAN Baud Rate

The controller can operate at J1939 standard 250 and 500 kbit/s baud rates. It can also run at 667kbit/s and 1Mbit/s – the maximum baud rate supported by the CAN hardware.

The baud rate selection is performed automatically upon connection to the CAN network using passive and active automatic baud rate detection process described in J1939/16. Once detected, the baud rate is stored in non-volatile memory and used on the next controller power-up.

The baud rate detection can be disabled for permanently installed units to maintain the desired baud rate on the CAN network.

2.3.2 J1939 Name and Address

Before sending and receiving any application data, the converter claims its network address with a unique J1939 Name. The Name fields are presented in the table below:

Table 2. J1939 Name Fields

Field Name	Field Length	Field Value	Configurable
Arbitrary Address Capable	1 bit	1 (Capable)	No
Industry Group	3 bit	0 (Global)	No
Vehicle System Instance	4 bit	0 (First Instance)	No
Vehicle System	7 bit	0 (Nonspecific System)	No
Reserved	1 bit	0	No
Function	8 bit	126 (IO Controller, Axiomatic proprietary)	No
Function Instance	5 bit	20 (AX032100, Axiomatic proprietary)	No
ECU Instance	3 bit	0 (First Instance)	Yes
Manufacturer Code	11 bit	162 (Axiomatic Technologies Corp.)	No
Identity Number	21 bit	Calculated on the base of the microcontroller unique ID	No

The user can change the controller *ECU Instance* using EA to accommodate multiple signal input controllers on the same CAN network.

The controller takes its network *ECU Address* from a pool of addresses assigned to self-configurable ECUs. The default address can be changed during an arbitration process or upon receiving a commanded address message. The new address value will be stored in a non-volatile memory and used next time for claiming the network address. The *ECU Address* can also be changed in EA.

2.3.3 Slew Rate Control

The controller has an ability to adjust the CAN transceiver slew rate for better performance on the CAN physical network, see J1939 Network function block for further details.

2.3.4 Network Bus Terminating Resistors

The controller does not have an embedded 120 Ohm CAN bus terminating resistor.

Terminating resistors should be installed externally on both ends of the CAN twisted pair cable according to the J1939/11(15) standards to avoid communication errors.

Even if the length of the CAN network is short and the signal reflection from both ends of the cable can be ignored, at least one 120 Ohm resistor is required for the majority of CAN transceivers to operate properly.

2.4 Modbus TCP Interface

The Modbus TCP/IP interface¹ runs over a standard 10/100 Mbit/s Ethernet link. The controller is presented as a slave device (a server) on the Modbus network. It supports with up to 8 simultaneous client connections from master devices.

¹The interface is compliant with:

- MODBUS Messaging on TCP/IP Implementation Guide V1.0b. Modbus Organization. October 24, 2006, 46p.
- MODBUS Application Protocol Specification V1.1b3. Modbus Organization. April 26, 2012, 50p.

The following Modbus functions are supported by the controller.

Table 3. Modbus Functions Supported by the Controller

Name	Function Code/Subcode	Description
Read Discrete Inputs	2	Reads values of the universal inputs when they are in the discrete voltage level mode
Read Input Registers	4	Reads values of the universal inputs
Read Holding Registers	3	Reads one or several configuration parameters
Write Single Register	6	Writes a configuration parameter
Write Multiple Registers	16	Writes one or several configuration parameters
Read/Write Multiple Registers	23	Writes and then reads configuration parameters
Encapsulated Interface Transport	43/14	Reads Device Identification

The Modbus addresses are presented in the MODBUS ADDRESS MAP section.

The Unit Identifier in the Modbus TCP header is ignored.

Floating-point variables are presented in a standard IEEE 754 single-precision 32-bit format, most significant word first. Double-word 32-bit integers are also presented with the most significant word first.

Reading and writing operations on variables occupying more than one word (a 16-bit Modbus register) are buffered. The buffering is made transparent to the user. However, it should be taken into consideration that writing to a non-volatile memory is not performed until all registers assigned to the variable are written. The writing operation should be performed without overlapping (writing to the same register twice) and without breaking the writing operation sequence with a reading operation or a writing operation to a different variable.

The Modbus functions “Write Multiple Registers” and “Read/Write Multiple Registers”, when they include all registers assigned to a variable in one function call, meet the abovementioned writing requirements.

The Modbus writing operations are subject to a validity check. If a configuration parameter value is not in a valid range, the Modbus operation will succeed, but the configuration parameter will not be written.

The following device identification information can be read using the Encapsulated Interface Transport 43/14 function.

Table 4. Modbus Device Identification

Object ID	Object Name	Description
0x00	VendorName	“Axiomatic”
0x01	ProductCode	Controller P/N. “AX032100”
0x02	MajorMinorRevision	Current firmware version. For example, “V1.00”
0x03	VendorUrl	“www.axiomatic.com”
0x04	ProductName	“IO Controller”
0x05	ModelName	Same as ProductCode. Controller P/N. “AX032100”
0x06	UserApplicationName	Firmware description. Depends on the firmware version. For V1.xx: “2 Bipolar, 8 Universal Signal Input Controller, SAE J1939, Ethernet”
0x80	SerialNumber	Private Object. Controller S/N. For example, “0012020016”

All device identification objects are presented in ASCII strings.

2.5 Discovery Protocol

The controller supports an Axiomatic proprietary protocol that allows the discovery of Axiomatic controllers on a LAN by sending a global UDP request on port 35100¹.

¹ O. Bogush, "Ethernet to CAN Converter Discovery Protocol. CAN-ENET, AX140900, Project 15129. Document version: 1," Axiomatic Technologies Corporation, October 26, 2016.

Axiomatic provides a Windows console application `AxioDisc.exe` that can be used to discover the controller. The application shows the controller MAC address, IP address, web server port (not used), device port (Modbus port), device port type (TCP), the controller part number and serial number, see Figure 2.

The `AxioDisc.exe`. application is available upon request.

```

Command Prompt
-----
Program: AxioDisc V1.0.0
(c) 2016, Axiomatic Technologies Corporation

This program discovers Axiomatic units on the LAN
using: "Ethernet to CAN Converter Discovery Protocol V1".
-----
          MAC          IP    WebPort    DevPort    DevPortType          P/N          S/N
-----
B4:37:D1:A0:00:01    192.168.0.34          0          502          TCP          AX032100    0012020016

```

Figure 2. Discovery of the Controller on LAN Using *AxioDisc.exe* Application

2.6 LED Indicators

The controller has two LED Indicators: Ethernet and CAN/System LEDs.

2.6.1 Ethernet LED

The Ethernet LED is a bi-color green-yellow indicator that shows Ethernet link and speed status. The green color presents the Ethernet link status and the yellow color – the Ethernet speed, see the table below.

Table 5. Ethernet LED

LED	Description
Off	No Link
Green	Link On. Speed 10Mbit/s
Blinking Green	Activity. Speed 10Mbit/s
Green and Yellow	Link On. Speed 100Mbit/s
Blinking Green and Yellow	Activity. Speed 100Mbit/s

The Ethernet bi-color LED is hard wired to the Ethernet PHY.

2.6.2 CAN/System LED

The CAN/System LED is a bi-color green-red indicator that shows CAN bus status and some global system conditions, see the table below.

Table 6. CAN/System LED

LED	Status	Description
Constant Green	CAN	CAN link is established
Blinking Green		CAN activity. CAN communication is running
Constant Red		CAN error
Flashing Red	System	Unrecoverable system error. Device failure
Flashing Green/Red		Device is in the bootloader mode

2.7 Default Settings

The controller *Bipolar* and *Universal Inputs* are configured to input voltages in the 0...5V voltage range by default. These voltages can be read through Modbus interface.

The CAN output messages are not set up by default. They can be configured to accommodate user-specific application requirements, see Configuration Example in CONTROLLER CONFIGURATION section.

3 CONTROLLER LOGICAL STRUCTURE

The controller is internally organized as a set of function blocks, which can be individually configured and arbitrarily connected together to achieve the required system functionality, see Figure 3.

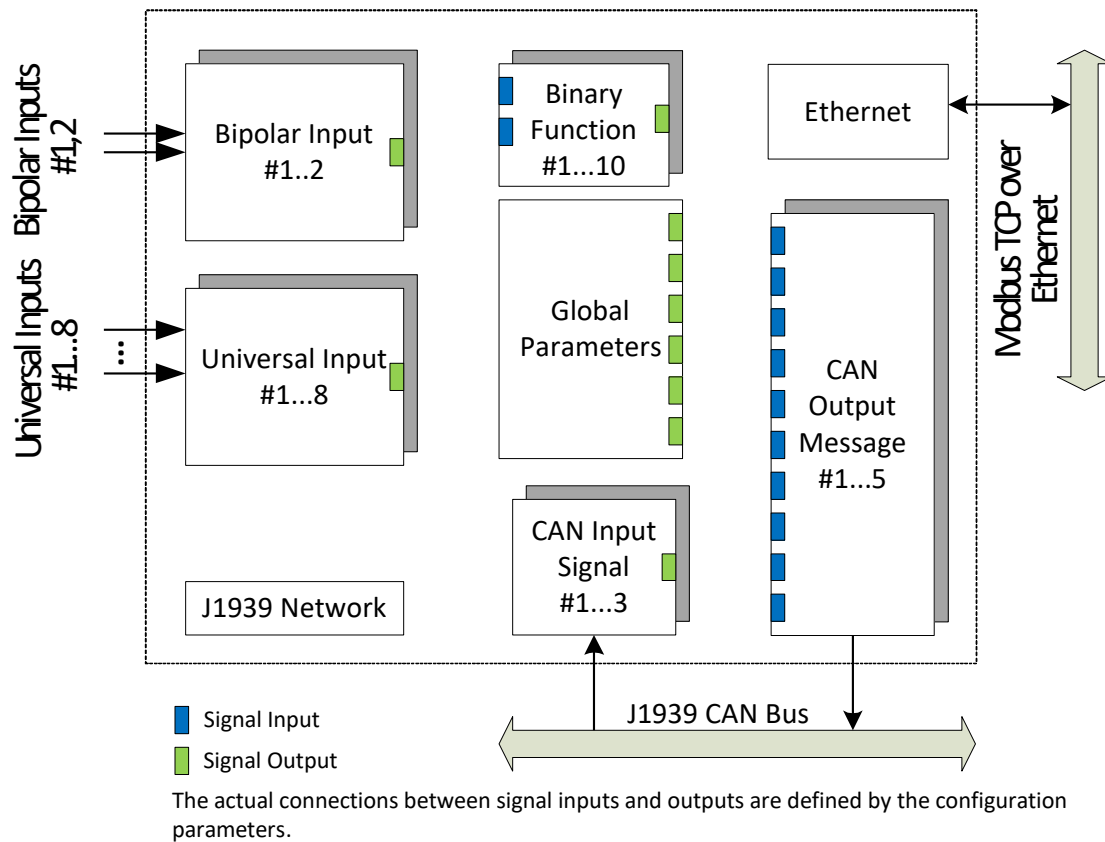

Figure 3. The Controller Logical Block Diagram

Each function block is absolutely independent and has its own set of configuration parameters, aka setpoints. The configuration parameters can be viewed and changed through CAN bus using Axiomatic Electronic Assistant® (EA) software or over Modbus interface.

The *Bipolar* and *Universal Input* function blocks present the controller physical input channels. Both function blocks can measure multiple physical parameters. The difference between them is in voltage and resistance measurements, see the table below.

Table 7. Bipolar vs Universal Function Blocks

Function Block	Voltage Measurements	Resistance Measurements
Bipolar	Bipolar	Absent
Universal	Unipolar, only positive voltages	Present

The J1939 CAN interface is presented by the *CAN Input Signal*, *CAN Output Message* and *J1939 Network* function blocks. The *CAN Input Signal* functional blocks are used to receive CAN signals transmitted on the CAN bus. They have one signal output, which is updated once the signal is received. The *CAN Output Message* function blocks are used to transmit CAN signals on the CAN bus. Each CAN message can hold up to ten individual CAN output signals, receiving data from their own signal inputs.

The Modbus interface is presented by the *Ethernet* function block that contains Modbus TCP/IP network settings.

For data processing, when required, there are ten *Binary Function* blocks. They can take two input signals and combine them together in one output signal using different functions.

The converter also has a *Global Parameters* function block containing four constant output signals and other auxiliary outputs.

3.1 Function Block Signals

The controller function blocks can communicate with each other through internal signal inputs and outputs. Each signal input of one function block can be connected to any signal output of another function block using an appropriate configuration parameter. There is no limitation on the number of signal inputs connected to one signal output.

When a signal input is connected to a signal output, data from the signal output of one function block is available on the signal input of another function block.

Function block signals can be “Undefined”, “Discrete” or “Continuous”. The “Undefined” signal type is reserved for a disconnected signal source or a no-signal transient condition. The “Discrete” and “Continuous” signal types are used to communicate discrete and continuous signals, respectively.

Discrete signals present data with a finite number of states. They are stored in four-byte unsigned integer variables that can present any state in the 0...0xFFFFFFFF range.

Continuous signals present continuous data, usually physical parameters. They are stored in single-precision floating-point variables. The continuous signals are not normalized and usually present data in physical units.

When a discrete signal output is connected to a continuous signal input, the discrete signal is converted into a positive continuous signal of the same value.

When a continuous signal output is connected to a discrete signal input, the following rules apply. A positive continuous signal is converted into the same value discrete signal. A fractional part of the continuous signal is truncated. If the continuous signal is above the maximum discrete signal value, it is saturated to the maximum discrete signal value: 0xFFFFFFFF. All negative continuous signals are converted into zeros.

The undefined signals are converted into zeros unless the function block can process the undefined signal state, for example: *CAN Output Message* function block will output all ones for undefined signals or *Binary Function* block will use default signal configuration parameters to define the signal value when the signal is in the undefined state.

3.2 Output Signal Sources

The controller output signal sources of all function blocks are presented in the table below.

Table 8. Controller Signal Sources

Signal Source Number	Signal Name	Signal Type
0	Not Connected	Undefined
1	Bipolar Input #1	Discrete or Continuous ¹
2	Bipolar Input #2	Discrete or Continuous ¹
3	Universal Input #1	Discrete or Continuous ¹
4	Universal Input #2	Discrete or Continuous ¹
5	Universal Input #3	Discrete or Continuous ¹
6	Universal Input #4	Discrete or Continuous ¹
7	Universal Input #5	Discrete or Continuous ¹
8	Universal Input #6	Discrete or Continuous ¹
9	Universal Input #7	Discrete or Continuous ¹
10	Universal Input #8	Discrete or Continuous ¹
11	Binary Function #1	Continuous
12	Binary Function #2	Continuous
13	Binary Function #3	Continuous
14	Binary Function #4	Continuous
15	Binary Function #5	Continuous
16	Binary Function #6	Continuous
17	Binary Function #7	Continuous
18	Binary Function #8	Continuous
19	Binary Function #9	Continuous
20	Binary Function #10	Continuous
21	CAN Input Signal #1	Any ²
22	CAN Input Signal #2	Any ²
23	CAN Input Signal #3	Any ²
24	Global Discrete Constant Signal	Discrete
25	Global Continuous Constant Signal	Continuous
26	Global Constant Signal = 0	Continuous
27	Global Constant Signal = 1	Continuous
28	Supply Voltage	Continuous
29	Microcontroller Temperature	Continuous

¹ Depends on the *Input Parameter*.

² Depends on the *Signal Type* configuration parameter.

3.3 Bipolar Inputs

The *Bipolar Input* function block translates physical input signals into the internal function block output signal that can be used by other function blocks of the controller. The *Bipolar Input* can measure bipolar voltages and other physical parameters but cannot measure input resistance.

There are two independent *Bipolar Input* function blocks presenting their own bipolar physical inputs.

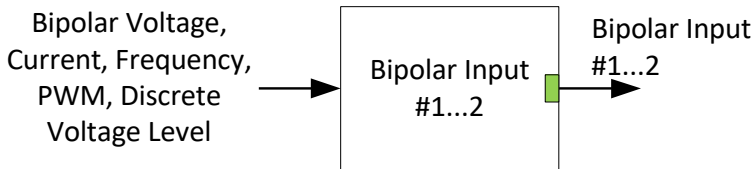

Figure 4. Bipolar Input Function Block

The internal function block output signal type and units of measurement are presented below.

Table 9. Bipolar Input Function Block Output Signal

Input Parameter	Signal Type	Units
Voltage	Continuous	V
Current	Continuous	mA
Discrete Voltage Level	Discrete	{0,1}
Frequency	Continuous	Hz
PWM Duty Cycle	Continuous	%

Each *Bipolar Input* function block has the following configuration parameters.

Table 10. Bipolar Input Function Block Configuration Parameters

Parameter	Default Value	Range	Units	Description
Input Parameter	1 - Voltage	0 - Input Disabled, 1 - Voltage, 2 - Current, 4 - Discrete Voltage Level, 5 - Frequency, 6 - PWM Duty Cycle	–	Defines the input physical parameter that will be measured by the function block.
Voltage Range	0 - 0...5V	0 - 0...5 V, 1 - 0...10 V, 2 - -5...5 V, 3 - -10...10 V	bit/s	Used in the "Voltage" mode
Current Range ¹	0 - 0...20 mA	0 - 0...20mA, 1 - 4...20 mA	mA	Used in the "Current" mode
Voltage LoZ Input	0 - No	0 - No, 1 - Yes	–	Activates a 10kOhm pull-down resistor to avoid ghost voltages in the "Voltage" mode. Warning: Measurement accuracy will be decreased!
Analog Input Filter	0 - Disabled	0 - Disabled, 1 - 50Hz Noise Rejection, 2 - 60Hz Noise Rejection, 3 - Both: 60Hz and 50Hz Noise Rejection	–	Noise Rejection in "Voltage" and "Current" modes
Pull-Up/Pull-Down Resistor	0 - Disabled	0 - Disabled, 1 - 10kOhm Pull-Up, 2 - 10kOhm Pull-Down	–	Used in "Discrete Voltage Level", "Frequency", and

Parameter	Default Value	Range	Units	Description
				"PWM Duty Cycle" modes.
Input Polarity	0 - Active High	0 - Active High, 1 - Active Low	–	Used in "Discrete Voltage Level", "Frequency", and "PWM Duty Cycle" modes.
Discrete Input Debounce Time	50ms	0...1000	ms	Used in "Discrete Voltage Level" mode. If 0 - no debouncing.
Frequency Range ² for <i>Bipolar Input #1</i>	0 - 1Hz...10kHz	0 - 1Hz...10kHz	Hz	One extended range is available due to 32-bit counter. Used in "Frequency", and "PWM Duty Cycle" modes.
Frequency Range ² for <i>Bipolar Input #2</i>	0 - 100Hz...10kHz	0 - 100Hz...10kHz, 1 - 10Hz...1kHz, 2 - 1Hz...100Hz	Hz	A 16-bit shared counter is used. The parameter is configured in <i>Universal Input #3</i> . Used in "Frequency", and "PWM Duty Cycle" modes.
Frequency/PWM Debounce Filter	0 - Disabled	0 - Disabled, 1 - 142ns, 2 - 1.14us, 3 - 6.10us	–	Used in "Frequency", and "PWM Duty Cycle" modes.
Frequency/PWM Averaging	0 - No Averaging	0 - No Averaging, 1 - 3 Readings, 2 - 5 Readings, 3 - 10 Readings	–	Defines a moving average filter used in "Frequency", and "PWM Duty Cycle" modes.

¹ Input currents below 3mA are output as 0mA when 4...20 mA current range is set.

² The *Frequency Range* parameter is different for *Bipolar Input #1* and *#2*.

3.3.1 Voltage Measurements

The *Bipolar Inputs* can measure voltages in voltage ranges set by the *Voltage Range* configuration parameter.

To avoid an influence of ghost voltages, the *Voltage LoZ Input* configuration parameter can be activated. This will reduce the accuracy of voltage measurements due to the influence of the 10kOhm pull-down shunt resistor and should be used only after careful consideration of the shunt resistor influence on the measured circuit.

The user can set the *Analog Input Filter* configuration parameter to reduce noise in voltage and other analog signal measurements. The filter is designed to suppress noise from industrial offline voltages. Even when the analog input filter is disabled, the minimum signal filtering is still performed by the function block. The parameters of the analog input filter are presented below.

Table 11. Bipolar Input Analog Input Filter Parameters

Analog Input Filter	Cut-off Frequency (at -3dB)	Settling Time (to 100% of Final Value)	Output Signal Update Rate
Disabled ¹	70Hz	10ms	1.67ms
50Hz Noise Rejection	12Hz	76.7ms	3.33ms
60Hz Noise Rejection	14Hz	63.3ms	3.33ms
Both: 60Hz and 50Hz Noise Rejection	2.3Hz	396.7ms	16.67ms

¹ Minimum signal filtering is still performed.

3.3.2 Current Measurements

There are two standard current ranges available for current measurements. When the current is below 3mA in the “4...20mA” current range, the output will be forced to zero to facilitate detection of an open circuit condition on the *Bipolar Input*.

The *Analog Input Filter* can be set to reduce the input noise.

3.3.3 Discrete Voltage Level

The *Bipolar Inputs* can accept discrete voltage levels. The user should specify the input polarity and define whether the pull-up/pull-down resistor is necessary on the input.

When the “10kOhm Pull-Up” is selected, the pull-up resistor is connected to the internal +14V power supply.

The input states are sampled every 1ms. If debouncing is required, it is set by the *Discrete Input Debounce Time* configuration parameter. If the *Discrete Input Debounce Time* is zero, the discrete voltage level input is not debounced.

3.3.4 Frequency and PWM

The frequency and PWM duty cycle measurements are performed by counting high-frequency internal clock pulses on every period of the input signal. The bipolar input channels have different internal organization due to limited hardware resources.

The *Bipolar Input #1* uses a 32-bit dedicated counter and has the widest frequency range among all bipolar and universal inputs of the controller. The *Bipolar Input #2* uses a standard 16-bit counter and shares its *Frequency Range* and *Frequency/PWM Debounce Filter* settings with the *Universal Input #3*, see the table below.

Table 12. Bipolar Input Function Block Counters

Function Block	Counter	Frequency Range	Counter Base	Shared Input	Frequency Range and Debounce Filter Setting
Bipolar Input #1	32-bit	1Hz...10kHz	Dedicated	N/A	Same input
Bipolar Input #2	16-bit	100Hz...10kHz, 10Hz...1kHz, 1Hz...100Hz	Shared Only	Universal Input #3	Universal Input #3

When the counter base is dedicated, the counter is synchronized with the input signal. This allows more accurate frequency and PWM duty cycle measurements. If the counter base is shared, the counter is free running. This causes a small jitter in the input measurements. To

avoid this jitter, use counters with the dedicated counter base when possible in the customer's applications.

To measure frequency or PWM duty cycle, the user should select the *Frequency Range* (only for *Bipolar Input #2* through the *Universal Input #3*) and then define how the *Input Polarity*, *Pull-Up/Pull-Down Resistor*, *Frequency/PWM Debounce Filter*, and the *Frequency/PWM Averaging* parameters should be set.

The *Input Polarity* defines the active edge of the input signal. The *Pull-Up/Pull-Down Resistor* can be used to pull the input to a no-signal state to avoid an undefined input condition when the signal source is disconnected. The *Input Polarity* and *Pull-Up/Pull-Down Resistor* are normally set the following way.

Table 13. Setting Pull-Up/Pull-Down Resistor for Selected Input Polarity. Bipolar Inputs

Input Polarity	Pull-Up/Pull-Down Resistor
Active High	"Disabled" or "10kOhm Pull-Down"
Active Low	"Disabled" or "10kOhm Pull-Up"

The frequency/PWM debounce filter is used to filter out parasitic spikes that can be present in a noisy input signal. It can be helpful to prevent the input from going into the Recovery state (see 3.3.4.1 Special Conditions) when, for example, mechanical switches are used to commutate the input signal.

The debounce filter should be used with caution since it can reduce the accuracy and resolution of frequency and PWM measurements if the debouncing time is not significantly less than the period of the input signal or the PWM pulse duration.

For the *Bipolar Input #2*, the *Frequency/PWM Debounce Filter* configuration parameter is set in the *Universal Input #3* function block.

When a frequency or PWM signal presents a slowly changing parameter, setting an additional moving average filter using the *Frequency/PWM Averaging* configuration parameter can be helpful in smoothing the results of the input measurements.

3.3.4.1 Special Conditions

Frequencies below the Minimum Frequency value will be measured as zero and frequencies above the Maximum Frequency value will saturate at the Maximum Frequency value for the selected *Frequency Range*, see Table 14 and Table 15.

Table 14. Maximum, Minimum Frequencies and Maximum Recovery Time for Bipolar Inputs

Frequency Range	Counter	Minimum Frequency	Maximum Frequency	Maximum Recovery Time
1Hz...10kHz	32-bit	0.5Hz	12.5kHz	2s
100Hz...10kHz	16-bit	91.55Hz	12.5kHz	10.9ms
10Hz...1kHz		9.155Hz	1.25kHz	109ms
1Hz...100Hz		0.9155Hz	125Hz	1.09s

Frequencies above the Maximum Frequency value will switch the input to the Recovery state. The input will stay in the Recovery state until the upcoming counter saturation event when the

frequency will be measured again. The input will leave the Recovery state if the measured frequency value is below the Maximum Frequency.

Table 15. Frequency and PWM Measurements for Bipolar Inputs. Special Conditions

Input Mode	Signal Frequency (F_s)			
	$F_s = 0$ Zero Frequency (DC)	$0 < F_s < F_{min}$ Below Minimum Frequency F_{min}	$F_{min} \leq F_s \leq F_{max}$ Working Frequency	$F_s > F_{max}$ Above Maximum Frequency F_{max}
Measured Frequency F_m	$F_m = 0$	$F_m = 0$	$F_m = F_s$	$F_m = F_{max}$ Recovery state
Measured PWM Duty Cycle D_m	$D_m = \{0, 100\}$	Undefined (not allowed)	$D_m = D_s$, D_s – signal duty cycle	$D_m = 0$ Recovery state

The time between two consequent counter saturation events defines the Maximum Recovery Time, see Table 14. This time is the maximum transient time when the measured frequency will stay equal to the Maximum Frequency value.

When the PWM signal is absent, the duty cycle is measured as 0 or 100% based on the voltage level on the input and the selected *Input Polarity*. The voltage level is sampled on the counter saturation events until the PWM signal is back on the input.

The transient time between the PWM signal duty cycle and the duty cycle of the DC level when the signal disappears can be up to the Maximum Recovery Time. During the transient time, the measured value will stay equal to the last measured value of the PWM signal duty cycle.

The PWM input signal with a frequency above zero but below the Minimum Frequency value is not allowed. The duty cycle will not be measured, instead, it will be jumping between 0% and 100% depending on the voltage level at the input on the counter saturation events.

When the PWM input signal frequency exceeds the Maximum Frequency value, the input goes into the Recovery state and the PWM duty cycle is measured as 0%. Similar to frequency measurements, the input will stay in the Recovery state for up to the Maximum Recovery Time before the duty cycle is measured again.

3.4 Universal Inputs

The *Universal Input* function block translates physical input signals into the internal function block output signal that can be used by other function blocks of the controller. In comparison with *Bipolar Inputs*, *Universal Inputs* can measure resistance, but the voltage measurements are limited to unipolar positive voltages.

There are 8 independent *Universal Input* function blocks presenting their own universal physical inputs.

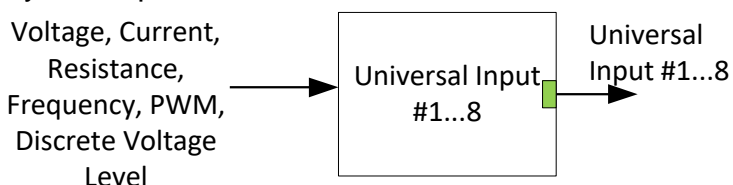

Figure 5. Universal Input Function Block

The internal function block output signal type and units of measurement are presented below.

Table 16. Universal Input Function Block Output Signal

Input Parameter	Type	Units
Voltage	Continuous	V
Current	Continuous	mA
Resistance	Continuous	Ohm
Discrete Voltage Level	Discrete	{0,1}
Frequency	Continuous	Hz
PWM Duty Cycle	Continuous	%

Each *Universal Input* function block has the following configuration parameters.

Table 17. Universal Input Function Block Configuration Parameters

Parameter	Default Value	Range	Units	Description
Input Parameter	1 - Voltage	0 - Input Disabled, 1 - Voltage, 2 - Current, 3 - Resistance, 4 - Discrete Voltage Level, 5 - Frequency, 6 - PWM Duty Cycle	–	Defines the input physical parameter that will be measured by the function block.
Voltage Range	0 - 0...5V	0 - 0...5 V, 1 - 0...10 V, 2 - -5...5 V, 3 - -10...10 V	bit/s	Used in the "Voltage" mode
Current Range ¹	0 - 0...20 mA	0 - 0...20mA, 1 - 4...20 mA	mA	Used in the "Current" mode
Resistance Range ²	0 - Auto Range	0 - Auto Range, 1 - 0...250Ohm, 2 - 0...2.5kOhm, 3 - 0...25kOhm, 4 - 0...250kOhm	Ohm	Used in the "Resistance" mode
Voltage LoZ Input	0 - No	0 - No, 1 - Yes	–	Activates a 10kOhm pull-down resistor to avoid ghost voltages in the "Voltage" mode. Warning: Measurement accuracy will be decreased!
Analog Input Filter	0 - Disabled	0 - Disabled, 1 - 50Hz Noise Rejection, 2 - 60Hz Noise Rejection, 3 - Both: 60Hz and 50Hz Noise Rejection	–	Noise Rejection in "Voltage", "Current" and "Resistance" modes
Pull-Up/Pull-Down Resistor	0 - Disabled	0 - Disabled, 1 - 10kOhm Pull-Up, 2 - 10kOhm Pull-Down	–	Used in "Discrete Voltage Level", "Frequency", and

Parameter	Default Value	Range	Units	Description
				"PWM Duty Cycle" modes.
Input Polarity	0 - Active High	0 - Active High, 1 - Active Low	–	Used in "Discrete Voltage Level", "Frequency", and "PWM Duty Cycle" modes.
Discrete Input Debounce Time	50ms	0...1000	ms	Used in "Discrete Voltage Level" mode. If 0 - no debouncing.
Frequency Range ³	0 - 100Hz...10kHz	0 - 100Hz...10kHz, 1 - 10Hz...1kHz, 2 - 1Hz...100Hz	Hz	A 16-bit counter is used. Used in "Frequency", and "PWM Duty Cycle" modes.
Frequency/PWM Debounce Filter ³	0 - Disabled	0 - Disabled, 1 - 142ns, 2 - 1.14us, 3 - 6.10us	–	Used in "Frequency", and "PWM Duty Cycle" modes.
Frequency/PWM Averaging	0 - No Averaging	0 - No Averaging, 1 - 3 Readings, 2 - 5 Readings, 3 - 10 Readings	–	Defines a moving average filter used in "Frequency", and "PWM Duty Cycle" modes.

¹ Input currents below 3mA are output as 0mA when 4...20 mA current range is set.

² Resistance below 10Ohm will be measured as 0 in the "Auto Range" or "0...250Ohm" resistance range.

³ Read-only in the *Universal Input #5* and *8*. Set in the *Universal Input #2* and *#1*, respectively.

3.4.1 Voltage Measurements

The *Universal Inputs* can measure voltages in voltage ranges set by the *Voltage Range* configuration parameter.

To avoid an influence of ghost voltages, the *Voltage LoZ Input* configuration parameter can be activated. This will reduce the accuracy of voltage measurements due to the influence of the 10kOhm pull-down shunt resistor and should be used only after careful consideration of the shunt resistor influence on the measured circuit.

The user can set the *Analog Input Filter* configuration parameter to reduce noise in voltage and other analog signal measurements. The filter is designed to suppress noise from industrial offline voltages. Even when the analog input filter is disabled, the minimum signal filtering is performed by the function block. The parameters of the analog input filter are presented below.

Table 18. *Universal Input Analog Input Filter Parameters*

Analog Input Filter	Cut-off Frequency (at -3dB)	Settling Time (to 100% of Final Value)	Output Signal Update Rate
Disabled ¹	70Hz	10ms	1.67ms
50Hz Noise Rejection	12Hz	76.7ms	3.33ms
60Hz Noise Rejection	14Hz	63.3ms	3.33ms
Both: 60Hz and 50Hz Noise Rejection	2.3Hz	396.7ms	16.67ms

¹ Minimum filtering is still performed.

3.4.2 Current Measurements

There are two standard current ranges available for current measurements. When the current is below 3mA in the “4...20mA” current range, the output will be forced to zero to facilitate detection of an open circuit condition on the *Universal Input*.

The *Analog Input Filter* can be set to reduce the input noise.

3.4.3 Resistance Measurements

The *Universal Inputs* can measure slowly changing input resistance, for example, a signal coming from a resistive temperature sensor.

The resistance measurements can be done in an auto-range or a predefined range mode set by the *Resistance Range* configuration parameter.

When the *Resistance Range* is set to “Auto Range”, a special algorithm is used to dynamically switch between resistance ranges to ensure that the resistance value is measured with the best accuracy and resolution, see the table below.

Table 19. Resistance Ranges as a Function of Input Resistance in the Auto Range Mode

Input Resistance	Resistance Range	
	Low-to-High Resistance Change	High-to-Low Resistance Change
< 225 Ohm	0...250Ohm	
225...275Ohm	0...250Ohm	0...2.5kOhm
275Ohm...2.25kOhm	0...2.5kOhm	
2.25kOhm...2.75kOhm	0...2.5kOhm	0...25kOhm
2.75kOhm...22.5kOhm	0...25kOhm	
22.5kOhm...27.5kOhm	0...25kOhm	0...250kOhm
>27.5kOhm	0...250kOhm	

If switching between the measurement ranges is not desirable or it is necessary to reduce the measurement time, the *Resistance Range* can be set to one of the predefined measurement ranges.

The *Analog Input Filter* configuration parameter can be used to reduce the measurement noise. However, it can also add a delay that can be significant when several universal inputs are used to measure resistance.

There is only one current source shared with all *Universal Inputs* for resistance measurements, see Figure 1. When more than one *Universal Input* is used to measure resistance, the current source is switched between inputs dramatically increasing the measurement time, see the table below.

Table 20. Universal Input Resistance Measurement Delay

Resistance Measurement	Measurement Delay
No channel or range switching	0 – No delay

Resistance Measurement	Measurement Delay
Range switching only	$\begin{cases} T_{sw} + T_s, & \text{during range switching only} \\ 0, & \text{all other time – no delay} \end{cases}$ $T_{sw} = 30ms - \text{switching time}, T_s - \text{analog filter settling time}$
Channel switching (with or without range switching)	$\sum_{n=1}^N (T_{sw} + T_{sn}), \quad N > 1, \quad N - \text{number of channels}$ $n - \text{channel number}$

For example, if 5 universal inputs are used to measure resistance and *Analog Input Filter* is set to “Both: 60Hz and 50Hz Noise Rejection” in all universal inputs, the total delay between consequent measurements will be $5 * (30 + 396.7) = 2133.5 \text{ ms}$ or more than 2 seconds.

3.4.4 Discrete Voltage Level

The *Universal Inputs* can accept discrete voltage levels. The user should specify the input polarity and define whether the pull-up/pull-down resistor is necessary on the input.

When the “10kOhm Pull-Up” is selected, the pull-up resistor is connected to the internal +14V power supply.

The input states are sampled every 1ms. If debouncing is required, it is set by the *Discrete Input Debounce Time* configuration parameter. If the *Discrete Input Debounce Time* is zero, the discrete voltage level input is not debounced.

3.4.5 Frequency and PWM

The frequency and PWM duty cycle measurements are performed by counting high-frequency internal clock pulses on every period of the input signal. The universal input channels have different internal organization due to limited hardware resources.

All universal inputs use 16-bit counters with the same set of frequency ranges configured by the *Frequency Range* configuration parameter. *Universal Inputs #4,6, and 7* have their own dedicated counter base. *Universal Inputs #1,2,3,5, and 8* share their counter base together with the *Frequency Range* and *Frequency/PWM Debounce Filter* settings with other inputs, see the table below.

Table 21. Universal Input Function Block Counters

Function Block	Counter	Frequency Range	Counter Base	Shared Input	Frequency Range and Debounce Filter Setting
Universal Input #1	16-bit	100Hz...10kHz, 10Hz...1kHz, 1Hz...100Hz	Dedicated or Shared	Universal Input #8	Same input
Universal Input #2			Shared Only	Universal Input #5	Same input
Universal Input #3			Dedicated or Shared	Bipolar Input #2	Same input
Universal Input #4			Dedicated	N/A	Same input
Universal Input #5			Shared Only	Universal Input #2	Universal Input #2

Function Block	Counter	Frequency Range	Counter Base	Shared Input	Frequency Range and Debounce Filter Setting
Universal Input #6			Dedicated	N/A	Same input
Universal Input #7			Dedicated	N/A	Same input
Universal Input #8			Shared Only	Universal Input #1	Universal Input #1

When the counter base is in the dedicated mode, the counter is synchronized with the input signal. This allows more accurate frequency and PWM duty cycle measurements. If the counter base is shared, the counter is free running. This causes a small jitter in the input measurements. To avoid this jitter, use counters with the dedicated counter base when possible in the customer's applications.

Universal Inputs #1 and #3 run in the dedicated counter base mode if their shared inputs are not used for frequency or PWM measurements. *Universal Input #2* can run only in the shared counter base mode.

To measure frequency or PWM duty cycle, the user should first select the *Frequency Range* parameter and then define how the *Pull-Up/Pull-Down Resistor*, *Frequency/PWM Debounce Filter*, and the *Frequency/PWM Averaging* parameters should be set.

For the *Universal Inputs #5 and #8*, with the shared only counter base, the user should configure the *Frequency Range* and *Frequency/PWM Debounce Filter* parameters in the *Universal Input #2 and #1* function blocks, respectively. These settings will be shared between inputs.

The *Input Polarity* defines the active edge of the input signal. The *Pull-Up/Pull-Down Resistor* can be used to pull the input to a no-signal state to avoid an undefined input condition when the signal source is disconnected. The *Input Polarity* and *Pull-Up/Pull-Down Resistor* are normally set the following way.

Table 22. Setting Pull-Up/Pull-Down Resistor for Selected Input Polarity. Universal Inputs

Input Polarity	Pull-Up/Pull-Down Resistor
Active High	"Disabled" or "10kOhm Pull-Down"
Active Low	"Disabled" or "10kOhm Pull-Up"

The frequency/PWM debounce filter is used to filter out parasitic spikes that can be present in a noisy input signal. It can be helpful to prevent the input from going into the Recovery state (see 3.4.5.1 Special Conditions) when, for example, mechanical switches are used to commutate the input signal.

The debounce filter should be used with caution since it can reduce the accuracy and resolution of frequency and PWM measurements if the debouncing time is not significantly less than the period of the input signal.

When a frequency or PWM signal presents a slowly changing parameter, setting an additional moving average filter using the *Frequency/PWM Averaging* configuration parameter can be helpful in smoothing the results of the input measurements.

3.4.5.1 Special Conditions

Frequencies below the Minimum Frequency value will be measured as zero and frequencies above the Maximum Frequency value will saturate at the Maximum Frequency value for the selected *Frequency Range*, see Table 23 and Table 24.

Table 23. Maximum, Minimum Frequencies and Maximum Recovery Time for Universal Inputs

Frequency Range	Counter	Minimum Frequency	Maximum Frequency	Maximum Recovery Time
100Hz...10kHz	16-bit	91.55Hz	12.5kHz	10.9ms
10Hz...1kHz		9.155Hz	1.25kHz	109ms
1Hz...100Hz		0.9155Hz	125Hz	1.09s

Frequencies above the Maximum Frequency value will switch the input to the Recovery state. The input will stay in the Recovery state until the upcoming counter saturation event when the frequency will be measured again. The input will leave the Recovery state if the measured frequency value is below the Maximum Frequency.

Table 24. Frequency and PWM Measurements for Universal Inputs. Special Conditions

Input Mode	Signal Frequency (F_s)			
	$F_s = 0$ Zero Frequency (DC)	$0 < F_s < F_{min}$ Below Minimum Frequency F_{min}	$F_{min} \leq F_s \leq F_{max}$ Working Frequency	$F_s > F_{max}$ Above Maximum Frequency F_{max}
Measured Frequency F_m	$F_m = 0$	$F_m = 0$	$F_m = F_s$	$F_m = F_{max}$ Recovery state
Measured PWM Duty Cycle D_m	$D_m = \{0, 100\}$	Undefined (not allowed)	$D_m = D_s$, D_s – signal duty cycle	$D_m = 0$ Recovery state

The time between two consequent counter saturation events defines the Maximum Recovery Time, see Table 23Table 14. This time is the maximum transient time when the measured frequency will stay equal to the Maximum Frequency value.

When the PWM signal is absent, the duty cycle is measured as 0 or 100% based on the voltage level on the input and the selected *Input Polarity*. The voltage level is sampled on the counter saturation events until the PWM signal is back on the input.

The transient time between the PWM signal duty cycle and the duty cycle of the DC level when the signal disappears can be up to the Maximum Recovery Time. During the transient time, the measured value will stay equal to the last measured value of the PWM signal duty cycle.

The PWM input signal with a frequency above zero but below the Minimum Frequency value is not allowed. The duty cycle will not be measured, instead, it will be jumping between 0% and 100% depending on the voltage level at the input on the counter saturation events.

When the PWM input signal frequency exceeds the Maximum Frequency value, the input goes into the Recovery state and the PWM duty cycle is measured as 0%. Similar to frequency

measurements, the input will stay in the Recovery state for up to the Maximum Recovery Time before the duty cycle is measured again.

3.5 Binary Functions

There are ten *Binary Function* blocks available to the user for performing simple data conversions. Each *Binary Function* block has two signal inputs and one signal output.

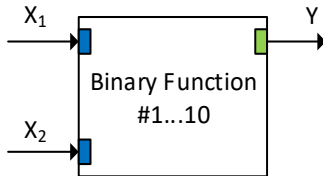

Figure 6. Binary Function Block

The *Binary Function* block performs the following data conversion:

$$Y = A \cdot F[a_1 \cdot f_1(X_1) + b_1; a_2 \cdot f_2(X_2) + b_2] + B, \quad n = 1,2; \quad (1)$$

- where:
- X_n – Input signal;
 - $f_n(X_n)$ – Unary function;
 - a_n – Scale;
 - b_n – Offset;
 - $F[x; y]$ – Binary Function;
 - A – Output Scale;
 - B – Output Offset.

The function block input signals can be undefined. The user can specify a default signal value that will be used when the signal is not defined. If the default signal value is not specified, the output signal of the function block will become undefined too.

The following unary functions can be used to process the input signals.

Table 25. Unary Functions

Function Number	Function Name	Description	Comment
0	Undefined	$f(x) = x$	Signal is not processed
1	! Logical Not	$f(x) = !x$	x is converted into 4-byte unsigned integer before function is applied
2	~ Bitwise Not	$f(x) = \sim x$	x is converted into 4-byte unsigned integer before function is applied
3	abs(x) Absolute	$f(x) = x, \text{ if } x \geq 0$ $f(x) = -x, \text{ if } x < 0$	

The following binary functions are defined in the function block:

Table 26. Binary Functions

Function Number	Function Name	Description	Comment
0	Undefined	$F[x; y] = \text{Undefined}$	Output signal is undefined

Function Number	Function Name	Description	Comment
1	+ Addition	$F[x;y] = x + y$	
2	- Subtraction	$F[x;y] = x - y$	
3	* Multiplication	$F[x;y] = x * y$	
4	/ Division	$F[x;y] = x / y$	Division by 0 gives 0
5	% Modulus	$F[x;y] = x \% y$	x and y are converted into 4-byte unsigned integers before function is applied
6	max(x,y) Maximum	$F[x;y] = x$, if $x \geq y$ $F[x;y] = y$, if $x < y$	
7	min(x,y) Minimum	$F[x;y] = x$, if $x \leq y$ $F[x;y] = y$, if $x > y$	
8	== Equal	$F[x;y] = 1$, if $x = y$ $F[x;y] = 0$, if $x \neq y$	
9	!= Not Equal	$F[x;y] = 1$, if $x \neq y$ $F[x;y] = 0$, if $x = y$	
10	> Great	$F[x;y] = 1$, if $x > y$ $F[x;y] = 0$, if $x \leq y$	
11	>= Great Equal	$F[x;y] = 1$, if $x \geq y$ $F[x;y] = 0$, if $x < y$	
12	< Less	$F[x;y] = 1$, if $x < y$ $F[x;y] = 0$, if $x \geq y$	
13	<= Less Equal	$F[x;y] = 1$, if $x \leq y$ $F[x;y] = 0$, if $x > y$	
14	Logical OR	$F[x;y] = x \vee y$	x and y are converted into 4-byte unsigned integers before function is applied
15	&& Logical AND	$F[x;y] = x \wedge y$	x and y are converted into 4-byte unsigned integers before function is applied
16	Bitwise OR	$F[x;y] = x y$	x and y are converted into 4-byte unsigned integers before function is applied
17	& Bitwise AND	$F[x;y] = x \& y$	x and y are converted into 4-byte unsigned integers before function is applied
18	^ Bitwise XOR	$F[x;y] = x \wedge y$	x and y are converted into 4-byte unsigned integers before function is applied
19	<< Left Shift	$F[x;y] = x \ll y$	x and y are converted into 4-byte unsigned integers before function is applied
20	>> Right Shift	$F[x;y] = x \gg y$	x and y are converted into 4-byte unsigned integers before function is applied

The *Binary Function* has the following set of configuration parameters.

Table 27. Binary Function Block Configuration Parameters

Name	Default Value	Range	Units	Description
Binary Function	0 - Undefined	See Binary Function table	–	$F[x;y]$ – Binary function
Output Scale	1	Any value	–	A – Output Scale
Output Offset	0	Any value	–	B – Output Offset
Input #1 Signal Source	0 - Not Connected	Any signal output of any function block or "Not Connected". See Signal Source table.	–	X_1 – Input Signal #1

Name	Default Value	Range	Units	Description
Input #1 Signal Default	0 - No	0 - No, 1 - Yes	–	Defines whether the default signal value for X_1 is defined.
Input #1 Signal Default Value	0	Any value	–	X_1 default value, if <i>Input #1 Signal Default</i> is <i>Yes</i> .
Unary Function #1	0 - Undefined	See Unary Function table	–	$f_1(x)$ – Unary function #1
Scale #1	1	Any value	–	a_1 – Scale #1
Offset #1	0	Any value	–	b_1 – Offset #1
Input #2 Signal Source	0 - Not Connected	Any signal output of any function block or “Not Connected”. See Signal Source table.	–	X_2 – Input Signal #2
Input #2 Signal Default	1 - Yes	0 - No, 1 - Yes	–	Defines whether the default signal value for X_2 is defined.
Input #2 Signal Default Value	1	Any value	–	X_2 default value, if <i>Input #2 Signal Default</i> is <i>Yes</i> .
Unary Function #2	0 - Undefined	See Unary Function table	–	$f_2(x)$ – Unary function #2
Scale #2	1	Any value	–	a_2 – Scale #2
Offset #2	0	Any value	–	b_2 – Offset #2

3.6 Global Parameters

The *Global Parameters* functional block gives the user access to a set of global constants, unit supply voltage and the microcontroller internal temperature.

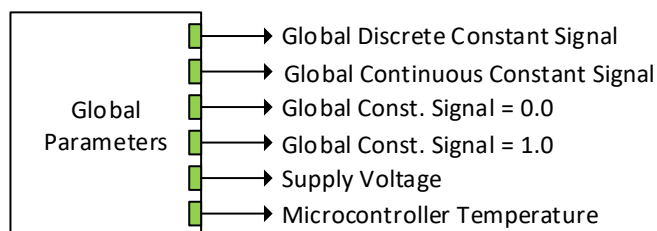

Figure 7. *Global Parameters Function Block*

The function block provides two pre-set (for 0 and 1) and two configurable global constant signals. It also provides the “Supply Voltage” signal presenting the controller supply voltage in [V] and the “Microcontroller Temperature” signal presenting the internal microcontroller temperature in [°C].

Please note, that the “Supply Voltage” signal does not present the voltage on the controller power supply connector pins. It shows an internal voltage measured after the EMI filter, reverse polarity, and transient protection circuit. It is always less than the actual power supply voltage by approximately 0.4 V.

The *Global Parameters* function block has the following configuration parameters.

Table 28. Global Parameters Function Block Configuration Parameters

Name	Default Value	Range	Units	Description
Global Continuous Constant Signal	0	Any value	–	Signal value of the <i>Global Continuous Constant Signal</i> .
Global Discrete Constant Signal	0	0... 4294967295 (0xFFFFFFFF)	–	Signal value of the <i>Global Discrete Constant Signal</i> .

3.7 J1939 Network

The *J1939 Network* function block defines the global J1939 CAN bus settings. It does not have signal inputs and outputs.

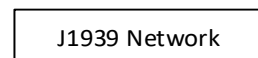

Figure 8. J1939 Network Function Block

Configuration parameters of the *J1939 Network* function block are presented below. They contain *ECU Network* and *CAN Network Parameters*.

Table 29. J1939 Network Function Block Configuration Parameters

Name	Default Value	Range	Units	Description
ECU Instance Number	0 - Instance #1	0...7	–	ECU Instance field of the J1939 ECU Name.
ECU Address	128	0...253	–	J1939 ECU address.
Baud Rate ¹	250	{250, 500, 667, 1000}	kbit/s	Current baud rate on the CAN network.
Automatic Baud Rate Detection	1 - Yes	0 - No, 1 - Yes	–	Set to “No” once ECU is permanently installed on the CAN network.
Slew Rate	0 - Low	0 - Low, 1 - High	–	Slew rate control of the CAN transceiver.

¹ Read-only parameter.

3.7.1 ECU Network Parameters

The user can change the *ECU Instance Number* and *ECU Address* to adjust the unit on the CAN network.

Changing the *ECU Instance Number* is necessary to accommodate multiple inclinometers on the same CAN network. The list of available ECU instances is shown in the *ECU Instance Number Setup* dialog window in EA. The user should select the required ECU instance number and then press OK or double-click the selected instance number.

The *ECU Address* is automatically adjusted as the result of an address arbitration process on the J1939 CAN network. It can also be changed by a commanded address message. The user can also manually change the ECU address using the *ECU Address* configuration parameter.

The user selects the new ECU address from the list of available ECU addresses in the *ECU Address Setup* dialog window in EA. After the required ECU address is selected, the user should press OK button or double-click the selected address.

3.7.2 CAN Network Parameters

The *Baud Rate* read-only configuration parameter shows the current baud rate on the CAN network.

The *Automatic Baud Rate Detection* parameter defines whether the ECU will try to detect the CAN baud rate in case of communication errors. The baud rate is detected from the list of supported CAN baud rates.

To avoid an arbitrary selection of the CAN baud rate by ECUs involved in the automatic baud rate detection process, it is necessary to disable the automatic baud rate detection in ECUs that are already permanently installed on the CAN network.

The *Slew Rate* configuration parameter defines the slew rate of the CAN transceiver the following way:

Table 30. Slew Rates

Slew Rate Value	Transceiver Slew Rate	Note
Fast	~40 V/μs	Available for all baud rates.
Slow	~6 V/ μs	Only available for 250kbit/s baud rate.

The user can select the *Slew Rate* only when the inclinometer operates at 250 kbit/s baud rate. For baud rates higher than 250 kbit/s, the *Slew Rate* is always set to “Fast” independently of the *Slew Rate* configuration parameter.

The “Slow” slew rate is preferable at 250 kbit/s baud rate in the majority of applications due to the reduced EMI of the CAN transceiver. The “Fast” slew rate, in this case, is used when the distance between CAN nodes substantially exceeds 40 m – the maximum value defined by the J1939/11(15) standard.

3.8 Ethernet

The *Ethernet* function block defines the Modbus TCP interface settings. It does not have signal inputs and outputs.

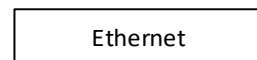

Figure 9. Ethernet Function Block

Configuration parameters of the *Ethernet* function block are presented below.

Table 31. Ethernet Function Block Configuration Parameters

Name	Default Value	Range	Units	Description
MAC Address	Set at the factory	Any valid MAC address	–	Ethernet MAC Address. Set at the factory. Read-only parameter.
IP Address	192.168.0.34	Any IP address	–	The device IP address
Subnet Mask	255.255.255.0	Any IP address	–	The device subnet mask
Gateway	192.168.0.1	Any IP address	–	The device default gateway
Modbus Port	502	Any port value except the	–	The Modbus listening port

Name	Default Value	Range	Units	Description
		Discovery Port (35100)		
Modbus Timeout	1000	1...10000	ms	The Modbus communication timeout. Not used in the current firmware.

Any updates to the function block configuration parameters will require a manual reset of the controller to apply the new Ethernet settings.

3.9 CAN Input Signals

There are three *CAN Input Signal* function blocks available to the user. Each function block represents one CAN input signal that can be received from the CAN bus. The function block has one signal output.

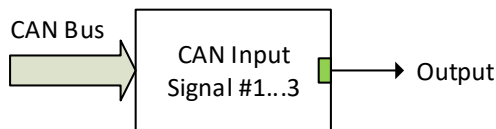

Figure 10. CAN Input Signal Function Block

The *CAN Input Signal* function block reads single-frame application-specific CAN messages and extracts CAN signal data presented in a user-defined data format. Different *CAN Input Signal* function blocks can read and process the same CAN message to extract different CAN signal data.

The CAN messages transmitted by the unit itself are also processed by *CAN Input Signal* function blocks. The only difference in processing of the internal messages is that they are not sampled from the CAN bus and therefore their processing does not depend on the state of the CAN bus.

Configuration parameters of the *CAN Input Signal* function block are presented below.

Table 32. CAN Input Signal Function Block Configuration Parameters

Name	Default Value	Range	Units	Description
Signal Type	0 - Undefined	0 - Undefined, 1 - Discrete, 2 - Continuous	–	CAN input signal type
PGN	65535	Any J1939 PGN value ¹	–	Signal message PGN value
PGN From Selected Address	0 - No	0 - No, 1 - Yes	–	Only CAN messages from the selected address will be accepted, if “Yes”
Selected Address	0	0...253	–	Address of the ECU transmitting CAN messages if <i>PGN From Selected Address</i> is set to “Yes”
Data Position Byte	1	1...8	–	Start byte of the CAN input signal in the CAN message data frame

Name	Default Value	Range	Units	Description
Data Position Bit	1	1...8	–	Start bit of the CAN input signal in the <i>Data Position Byte</i>
Size	1	1...32	bit	CAN input signal size.
Resolution	1	Any value	signal units / bit	CAN input signal resolution for continuous input signals
Offset	0	Any value	signal units	CAN input signal offset for continuous input signals
Autoreset Time	500	0...10000	ms	Function block signal output auto-reset time. If <i>Autoreset Time</i> is 0, the auto-reset is disabled.

¹*Proprietary A PGN (61184) is excluded. It is taken by Axiomatic Simple Proprietary Protocol and therefore cannot be used in function blocks.*

The CAN input signal position is defined within the CAN message data frame by the *Data Position Byte* and *Data Position Bit* configuration parameters the same way as in the J1939 standard. The start and stop bits of the CAN signal in the 64-bit CAN message data frame are calculated using the formulas:

$$StartBit = (DataPositionByte - 1) \cdot 8 + (DataPositionBit - 1), \quad (2)$$

$$StopBit = StartBit + Size - 1, \text{ where: } StartBit, StopBit \in [0 \dots 63].$$

Resolution and *Offset* configuration parameters are set for continuous CAN input signals. They are not used for discrete CAN signals.

The following rules apply when converting the CAN signal data to the function block output signal:

- Undefined CAN signals with all bits set to 1 are ignored.
- Discrete CAN signals can take any value except the one reserved for the undefined signal (all bits set to 1).
- Continuous CAN signals can take only values from the range reserved for continuous signals in the J1939 standard. If the CAN signal code is outside of this range presenting a special condition or an error, the signal is ignored.

When the *Autoreset Time* is not equal to 0, the function block will auto-reset the output signal to the undefined state if the output signal has not been updated within the auto-reset time frame by the new CAN message data.

3.10 CAN Output Messages

There are five *CAN Output Message* function blocks available to the user. Each function block presents one single frame CAN output message that can be sent on the CAN bus. The message can contain up to ten CAN output signals. Each CAN output signal is presented by its own signal input in the function block.

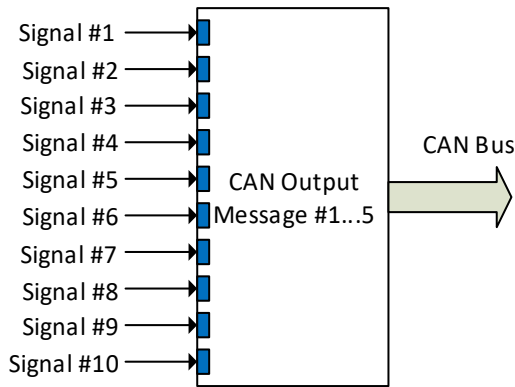

Figure 11. CAN Output Message Function Block

Configuration parameters of the *CAN Output Message* function block are presented below.

Table 33. CAN Output Message Function Block Configuration Parameters

Name	Default Value	Range	Units	Description
PGN	65535	Any J1939 PGN value ¹	–	CAN message PGN.
Transmission Enable	0 - No	0 - No, 1 - Yes	–	Enables the CAN output message transmission.
Transmission Rate	10	0...10000	ms	CAN output message transmission rate. If 0 – transmission is upon request.
Destination Address	255	0...255	–	Destination address of the PDU1 PGN messages.
Length	8	0...8	byte	CAN message data frame length.
Priority	6	0...7	–	CAN message priority.
Signal #1 Type	0 - Undefined	0 - Undefined, 1 - Discrete, 2 - Continuous	–	Type of the 1-st CAN output signal.
Signal #1 Source	0 - Not Connected	Any signal output of any function block or "Not Connected". See Signal Source table.	–	Input signal source of the 1-st CAN output signal.
Signal #1 Byte Position	1	1...8	–	Byte position of the 1-st CAN output signal.
Signal #1 Bit Position	1	1...8	–	Bit position of the 1-st CAN output signal.
Signal #1 Size	1	1...32	bit	Size of the 1-st CAN output signal.
Signal #1 Resolution	1	Any value	signal units / bit	Resolution of the 1-st CAN continuous output signal.
Signal #1 Offset	0	Any value	signal units	Offset of the 1-st CAN continuous output signal.
Signal #2 Type	0 - Undefined	0 - Undefined, 1 - Discrete,	–	Type of the 2-nd CAN output signal.

Name	Default Value	Range	Units	Description
		2 - Continuous		
Signal #2 Source	0 - Not Connected	Any signal output of any function block or "Not Connected". See Signal Source table.	–	Input signal source of the 2-nd CAN output signal.
Signal #2 Byte Position	1	1...8	–	Byte position of the 2-nd CAN output signal.
Signal #2 Bit Position	1	1...8	–	Bit position of the 2-nd CAN output signal.
Signal #2 Size	1	1...32	bit	Size of the 2-nd CAN output signal.
Signal #2 Resolution	0	Any value	signal units / bit	Resolution of the 2-nd CAN continuous output signal.
Signal #2 Offset	1	Any value	signal units	Offset of the 2-nd CAN continuous output signal.
...
Signal #10 Type	0 - Undefined	0 - Undefined, 1 - Discrete, 2 - Continuous	–	Type of the 10-th CAN output signal.
Signal #10 Source	0 - Not Connected	Any signal output of any function block or "Not Connected". See Signal Source table.	–	Input signal source of the 10-th CAN output signal.
Signal #10 Byte Position	1	1...8	–	Byte position of the 10-th CAN output signal.
Signal #10 Bit Position	1	1...8	–	Bit position of the 10-th CAN output signal.
Signal #10 Size	1	1...32	bit	Size of the 10-th CAN output signal.
Signal #10 Resolution	1	Any value	signal units / bit	Resolution of the 10-th CAN continuous output signal.
Signal #10 Offset	0	Any value	signal units	Offset of the 10-th CAN continuous output signal.

¹Proprietary A PGN (61184) is excluded. It is taken by Axiomatic Simple Proprietary Protocol and therefore cannot be used in function blocks.

Configuration parameters: *Signal #1...10 Byte Position* and *Signal #1...10 Bit Position*, together with the *Signal #1...10 Size* have the same meaning as in the *CAN Input Signal* function block. The user should be careful not to overlap the output signals.

The following rules apply when converting function block output signal data to the CAN signal code:

- Undefined signals are presented in the CAN signal code with all bits set to 1.
- Discrete signals are directly assigned to the CAN signal code without any conversion.
- Continuous signals are converted to the CAN signal code based on the *Signal #1...10 Resolution* and *Signal #1...10 Offset* configuration parameters. They are saturated to the

CAN continuous signal code boundaries defined in the J1939 standard when they go out of range.

4 CONTROLLER CONFIGURATION

The controller can be configured in two independent ways: through the Modbus or CAN interface.

4.1 Modbus Configuration

The controller can be configured through the Modbus TCP interface using any third-party software tools.

The configuration parameters are grouped by the function blocks, see the MODBUS ADDRESS MAP section.

The controller checks configuration parameters for validity before accepting them and writing in a non-volatile memory. If a configuration parameter is invalid, the Modbus writing function will succeed, but the configuration parameter will not be written.

The controller will reset all relevant function blocks after each change of the configuration parameters. The exception is the *Ethernet* function block that maintains the Ethernet connection. The user will need to perform a manual reset by cycling the controller power to start using the new Ethernet settings.

Any changes in CAN function blocks through Modbus will restart CAN communication of the controller.

4.2 CAN Configuration

The controller supports the J1939 memory access protocol for configuring the unit through the CAN interface. The Axiomatic PC-based Electronic Assistant® (EA) software can be used for viewing and changing the controller configuration parameters.

Axiomatic provides PC-based Electronic Assistant® (EA) software to communicate with a wide range of Axiomatic products. The software can be downloaded from the Axiomatic website www.axiomatic.com.

The EA uses the Axiomatic USB-CAN converter P/N AX070501 to connect to the CAN network. The converter with cables can be ordered as an EA kit P/N AX070502.

Please, refer to the user manual UMAX07050X for the description of the EA and associated products, and for the CAN network connection troubleshooting.

The user should use EA software version 5.15.113.0 or higher, which supports this controller firmware. The most recent EA software version can be downloaded from the Axiomatic website.

Before connecting to the CAN network, the user should ensure that the EA baud rate is the same as the baud rate used by ECUs on the network. The EA baud rate is displayed in the bottom-right corner of the EA screen and can be changed in the *Options* menu.

If the controller is the only one ECU on a temporary network set for configuring the unit, the EA baud rate should be set to the baud rate of the CAN network where the controller is planned to

be deployed. This baud rate will be stored in the ECU non-volatile memory and used by the unit on the next power-up.

Upon connection, EA will show the controller on the list of ECUs that are present on the J1939 CAN network. If the controller is the only one ECU on the network, the following screen will appear, see Figure 12.

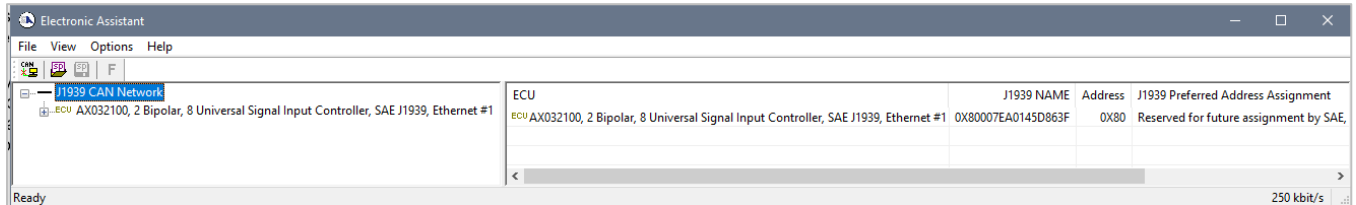

Figure 12. 2 Bipolar, 8 Universal Signal Input Controller with SAE J1939 and Ethernet in EA

The user can then browse through the ECU parameters, read *General ECU Information* and *Bootloader Information* groups, view and modify configuration parameters, see Figure 13.

The configuration parameters are grouped into function blocks. Please, refer to the appropriate section of this manual describing the required function block.

In the *General ECU Information* group, the user will see the version number of the application firmware. Please, make sure that the user manual version number matches with the most significant part of the application firmware version number. Otherwise, a different user manual is required to work with this controller.

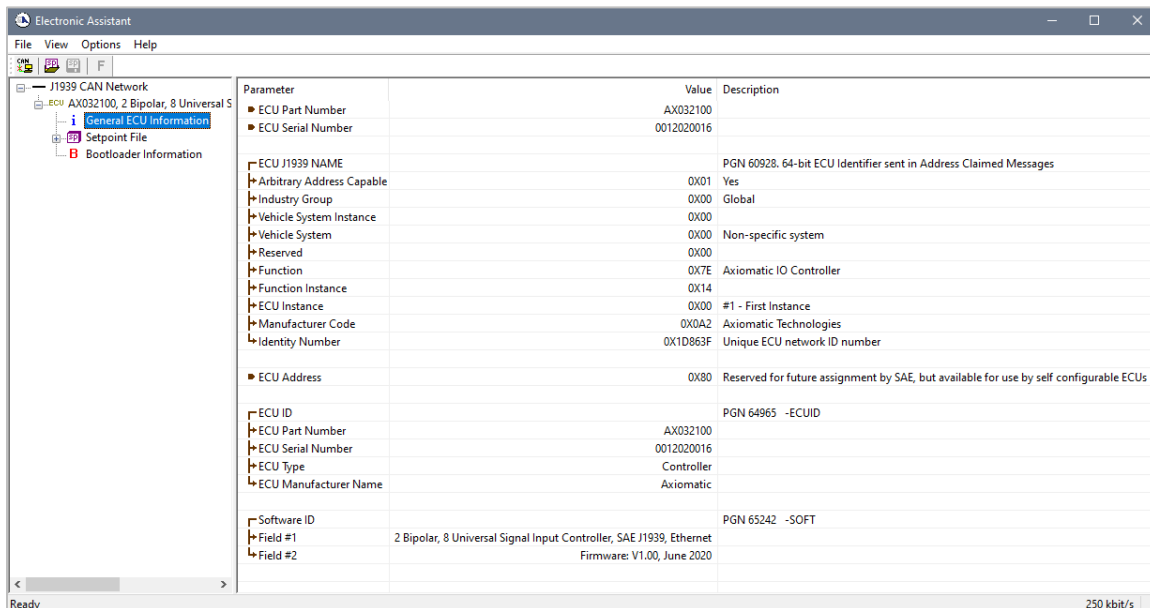

Figure 13. General ECU Information Screen

4.3 Function blocks in EA

Each controller function block is presented by its own setpoint group in the *Setpoint File* main group. Individual configuration parameters (setpoints) of a function block can be accessed through the function block setpoint group, see Figure 14.

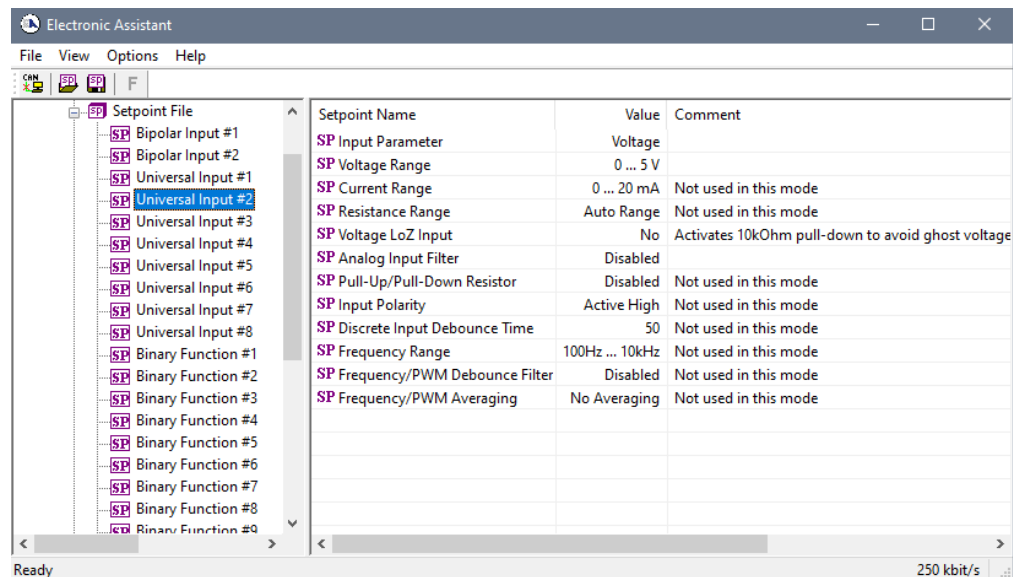

Figure 14. Bipolar Input #1 Function Block in EA

The user can view and, when necessary, change configuration parameters by double-clicking on the appropriate setpoint name. A pop-up dialog window will appear, see Figure 15.

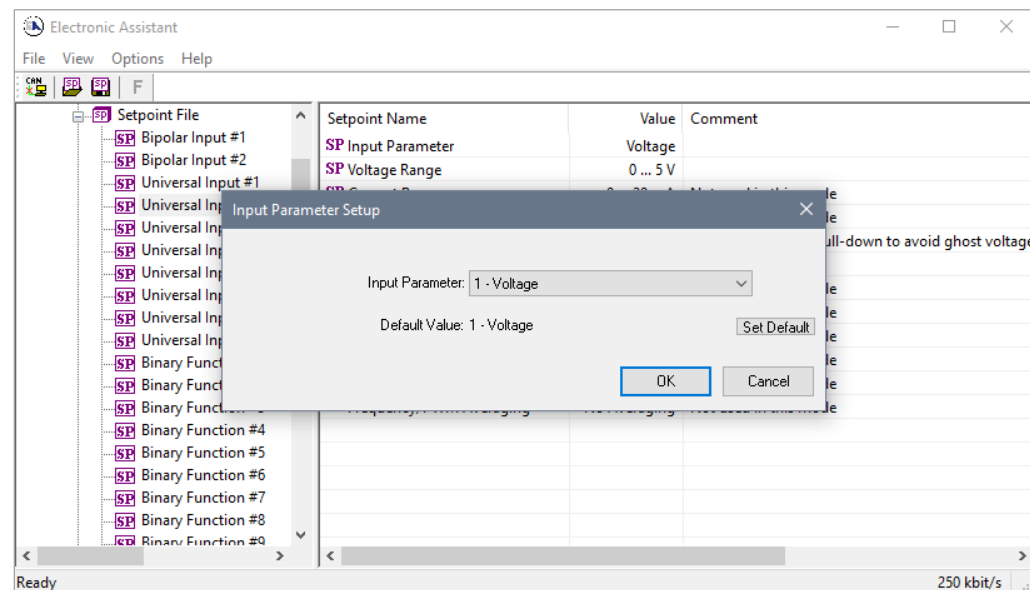

Figure 15. Changing a Configuration Parameter in EA

If the user changes the configuration parameter, the new value will be stored in a non-volatile memory and used immediately by the converter.

The controller will reset all relevant function blocks after each change of the configuration parameters. The exception is the *Ethernet* function block that requires a manual reset by cycling the controller power to apply the new Ethernet configuration parameters.

If the new configuration parameter affects the CAN network identification, the controller will reclaim its network address with a new network identification message.

4.4 Setpoint File

The EA can store all converter configuration parameters in one setpoint file and then flash them into the controller in one operation.

The setpoint file is created and stored on disk using a command *Save Setpoint File* from the EA menu or toolbar. The user then can open the setpoint file, view or print it, and also flash the setpoint file into the controller, see Figure 16.

The CAN network identification and “read-only” configuration parameters are not transferrable using this operation. Also, the controller will perform one or several internal resets of all function blocks during the setpoint flashing operation.

There can be small differences in configuration parameters between different versions of the application firmware. It is recommended that the user manually inspect all configuration parameters after flashing if the setpoint file was created by a different version of the application firmware.

Electronic Assistant

ECU Setpoint File

ECU Name: AX032100, 2 Bipolar, 8 Universal Signal Input Controller, SAE J1939, Ethernet #1
 Setpoint File: C:\Users\IOBogush\Documents\AX032100, 2 Bipolar, 8 Universal Signal Input Controller, SAE J1939, Ethernet #1-Setpoints.xml

ECU Identification

ECU J1939 NAME (PGN 60928): 0X80007EA0145D863F - 64-bit ECU Identifier

Field Name	Value	Description
Arbitrary Address Capable	0X01	Yes
Industry Group	0X00	Global
Vehicle System Instance	0X00	-
Vehicle System	0X00	Non-specific system
Reserved	0X00	-
Function	0X7E	Axiomatic IO Controller
Function Instance	0X14	-
ECU Instance	0X00	#1 - First Instance
Manufacturer Code	0X0A2	Axiomatic Technologies
Identity Number	0X1D863F	Unique ECU network ID number

ECU Address: 0X80 - Reserved for future assignment by SAE, but available for use by self configurable ECUs

ECU ID (PGN 64965 - ECUID):

Field Name	Value
ECU Part Number	AX032100
ECU Serial Number	0012020016
ECU Type	Controller
ECU Manufacturer Name	Axiomatic

Software ID (PGN 65242 -SOFT):

Field Number	Value
1	2 Bipolar, 8 Universal Signal Input Controller, SAE J1939, Ethernet
2	Firmware: V1.00, June 2020

Figure 16. EA Setpoint File

A setpoint file containing default configuration parameters is available upon request.

4.5 Configuration Example

A simple configuration example configuring CAN messages to output the controller input signals is presented below.

4.5.1 User Requirements

Let the controller is required to output two voltages in -10...10V range from *Binary Input #1* and *#2* in a proprietary PGN 65280 and a discrete voltage level from *Universal Input #1* in a proprietary PGN 65281. The PGN details are presented below.

Transmission Repetition Rate: 100 ms
 Data Length: 8
 Default Priority: 6
 Parameter Group Number: 65520 (Proprietary B)

Start Position	Length	Parameter Name	SPN
1	2 byte	VoltageOnBiIn1	N/A
3	2 byte	VoltageOnBiIn2	N/A

Parameter Name: VoltageOnBiIn1, VoltageOnBiIn2
 Data Length: 2 byte
 Resolution: 0.01 V/bit
 Offset: -321.27 V
 Type: Measured

Transmission Repetition Rate: 500 ms
 Data Length: 8
 Default Priority: 6
 Parameter Group Number: 65521 (Proprietary B)

Start Position	Length	Parameter Name	SPN
1.1	2 bits	DiscreteVLevelOnUIIn1	N/A

Parameter Name: DiscreteVLevelOnUIIn1
 Data Length: 2 bits

Bit 2	Bit 1	
0	0	Off – No voltage on <i>Universal Input #1</i> . Input is disconnected.
0	1	On – Positive voltage on <i>Universal Input #1</i>
1	0	Error
1	1	Not available

Type: Status

4.5.2 Configuration Steps

As a first step, we need to create a block diagram of the required unit configuration using the function blocks, see Figure 17. Limit our block diagram to the function blocks affected by the user requirements.

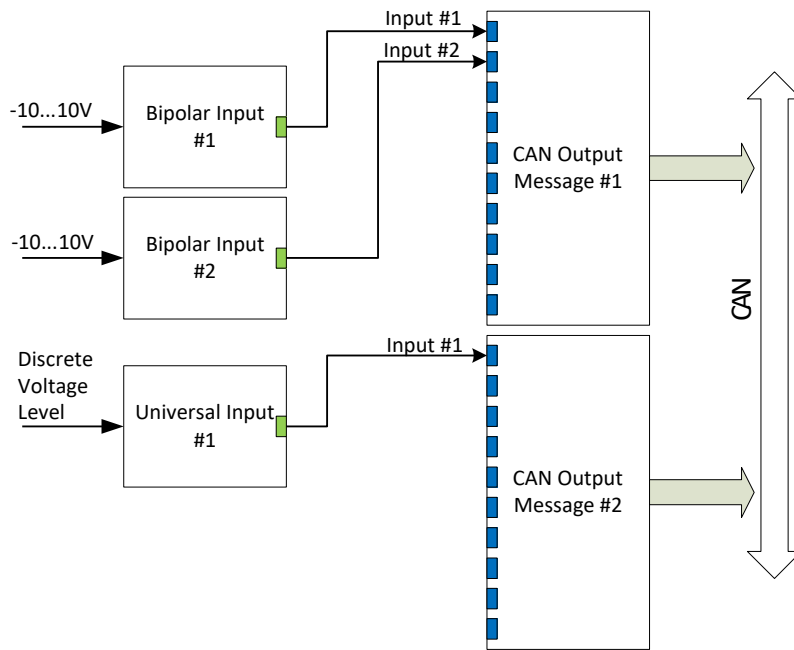

Figure 17. Block Diagram of the Example Configuration

Then configure each individual function block. Start with the *Bipolar Input #1*.

Set the *Input Parameter* to “Voltage” and *Voltage Range* to “-10...10V”. Keep the *Voltage LoZ Input* and *Analog Input Filter* at default settings, see Figure 18.

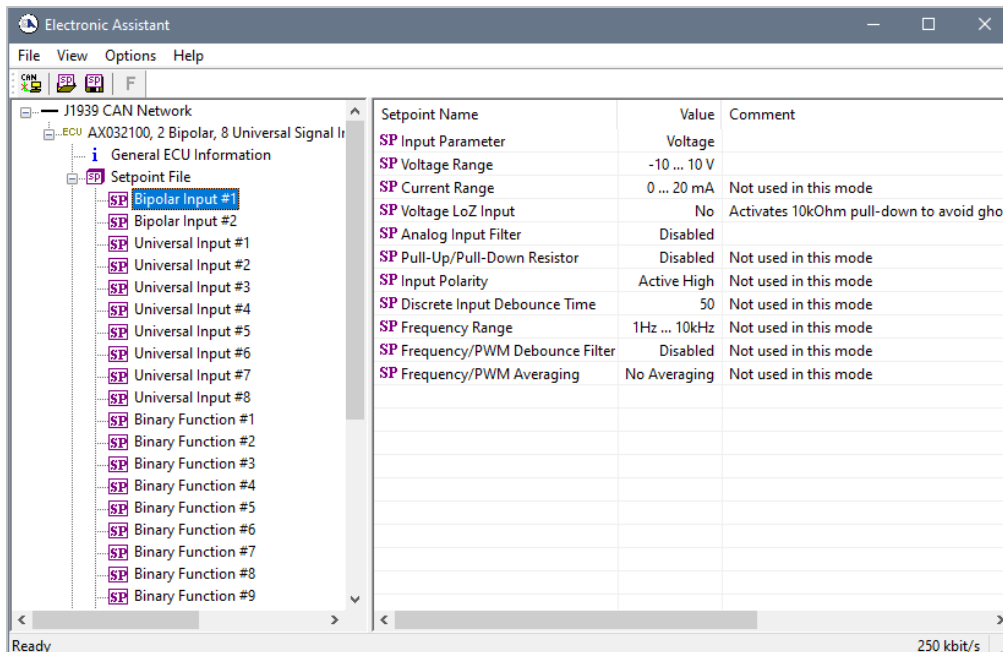

Figure 18. Bipolar Input #1 Example Configuration

Configure the *Bipolar Input #2* the same way as *Bipolar Input #1*. Then configure the *Universal Input #1* to input the discrete voltage level. Set the *Input Parameter* to “Discrete Voltage Level” and *Pull-Up/Pull-Down Resistor* to “10 kOhm Pull-Down” to maintain zero voltage level when

the input is disconnected. Keep the *Input Polarity* at “Active High” and *Discrete Input Debounce Time* at the default value, see Figure 19.

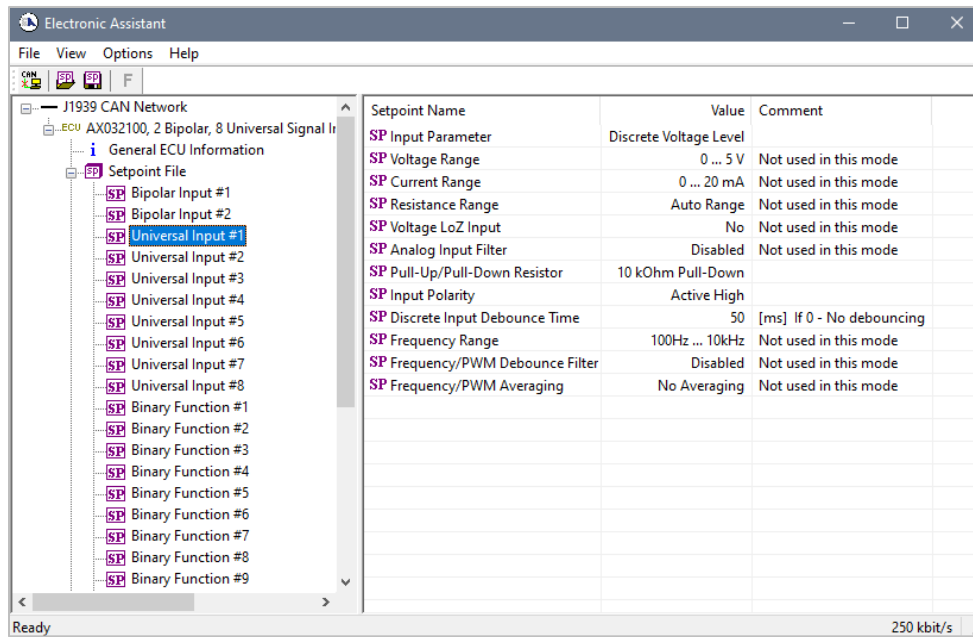

Figure 19. Universal Input #1 Example Configuration

Now configure CAN output messages. Configure *CAN Output Message #1*. First set common parameters to all CAN output signals. Set *PGN* to 65520, *Transmission Enable* to “Yes”, *Transmission Rate* to 100 ms. Keep default values for *Length* (8 bytes) and *Priority* (6), see Figure 20.

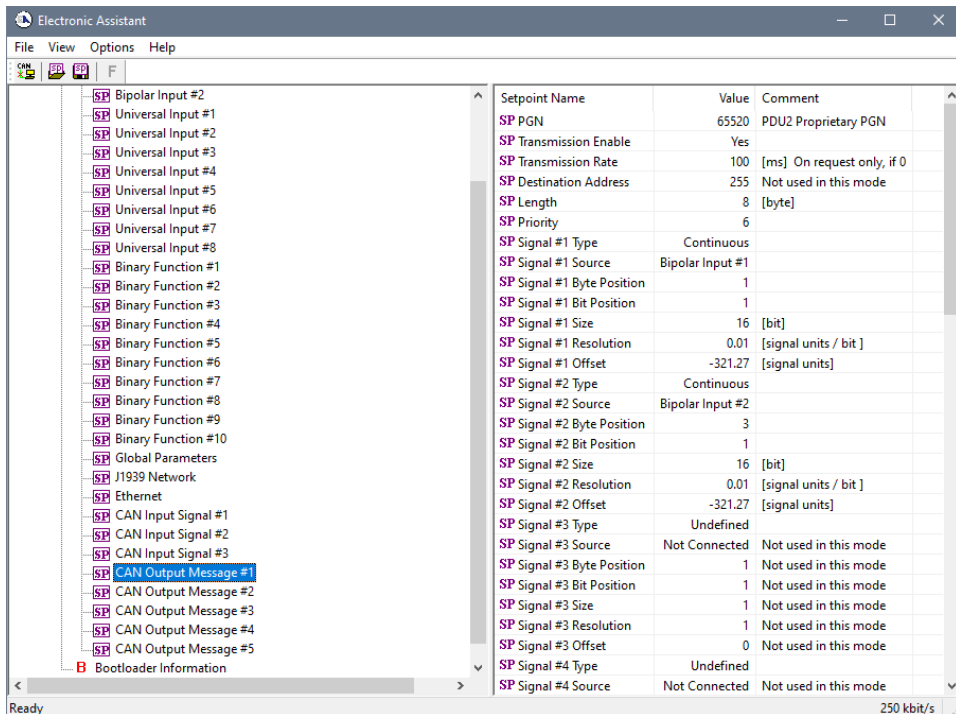

Figure 20. CAN Output Message #1 Example Configuration

Then configure the first CAN output signal. Set the *Signal #1 Type* to “Continuous”, connect the signal input to the *Bipolar Input #1* by setting *Signal #1 Source* to “Bipolar Input #1”, set *Signal #1 Byte Position* to 1, *Signal #1 Bit Position* to 1, *Signal #1 Size* to 16 bit, *Signal #1 Resolution* to 0.01 V/bit and *Signal #1 Offset* to -321.27 V.

In a similar way, configure signal #2. Set the *Signal #2 Type* to “Continuous”, *Signal #2 Source* to “Bipolar Input #2”, *Signal #2 Byte Position* to 3, *Signal #2 Bit Position* to 1, *Signal #2 Size* to 16 bit, *Signal #2 Resolution* to 0.01 V/bit and *Signal #2 Offset* to -321.27 V. Keep all other CAN signals in the default undefined state.

Then configure *CAN Output Message #2*. Set common parameters: *PGN* to 65521, *Transmission Enable* to “Yes”, *Transmission Rate* to 500 ms. Keep default values for *Length* (8 bytes) and *Priority* (6), see Figure 21.

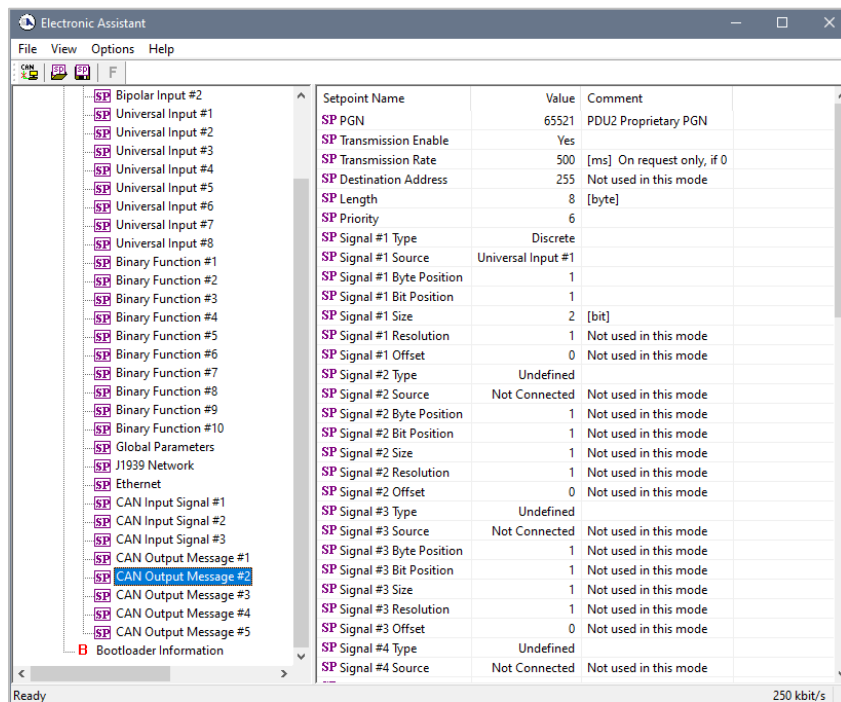

Figure 21. CAN Output Message #2 Example Configuration

Set the CAN output signal. Set the *Signal #1 Type* to “Discrete”, connect the signal input to the *Universal Input #1* by setting *Signal #1 Source* to “Universal Input #1”, set *Signal #1 Byte Position* to 1, *Signal #1 Bit Position* to 1, and *Signal #1 Size* to 2 bits. Keep all other CAN signals in the default undefined state.

The controller configuration is finished. Now the controller operates according to the new user requirements. The configuration parameters are already written to the non-volatile controller memory. The users can write them to a setpoint file for future use, if necessary.

The setpoint file for this example is available upon request. The user can monitor the controller performance using Axiomatic CAN Assistant – Scope (P/N AX070501SCO) and CAN Assistant – Visual (P/N AX070501VIS). The software is available for download from the Axiomatic website www.axiomatic.com.

5 FLASHING NEW FIRMWARE

When the new firmware becomes available, the user can replace the inclinometer firmware in the field using the unit embedded bootloader. The firmware file can be received from Axiomatic on request.

To flash the new firmware, the user should activate the embedded bootloader. To do so, start the EA and, in the *Bootloader Information* group screen, click on the *Force Bootloader to Load on Reset* parameter. The following dialog will appear, see Figure 22.

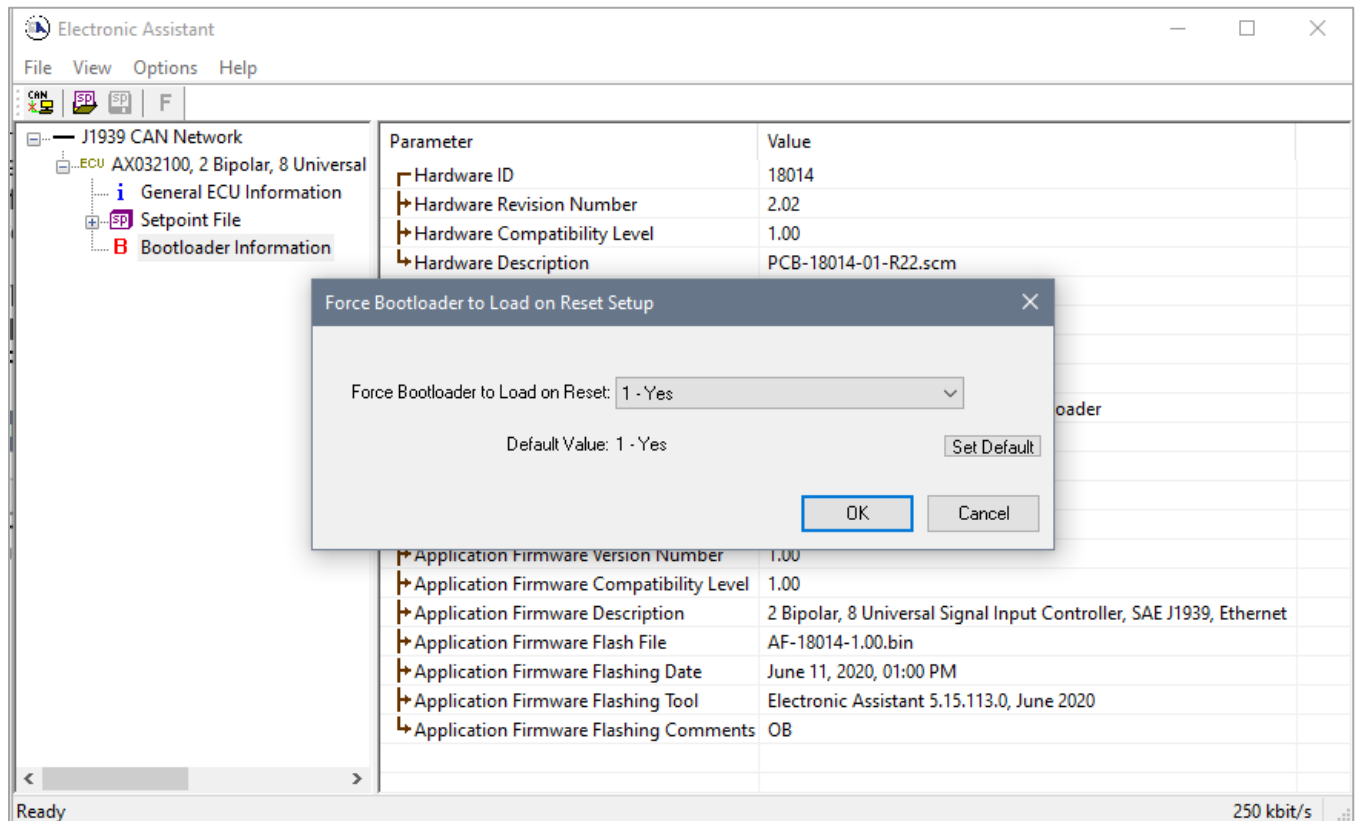

Figure 22. Bootloader Activation. First Step

The EA will prompt the user to change the *Force Bootloader to Load on Reset* parameter flag to “Yes”. This will automatically activate the bootloader on the next ECU reset. After accepting the change, the next screen will ask the user if the reset is actually required, see Figure 23. Select “Yes”.

After automatic reset, instead of *2 Bipolar, 8 Universal Signal Input Controller, SAE J1939, Ethernet*, the user will see *J1939 Bootloader* ECU in the *J1939 CAN Network* top-level group in the EA. This means that the bootloader is activated and ready to accept the new firmware.

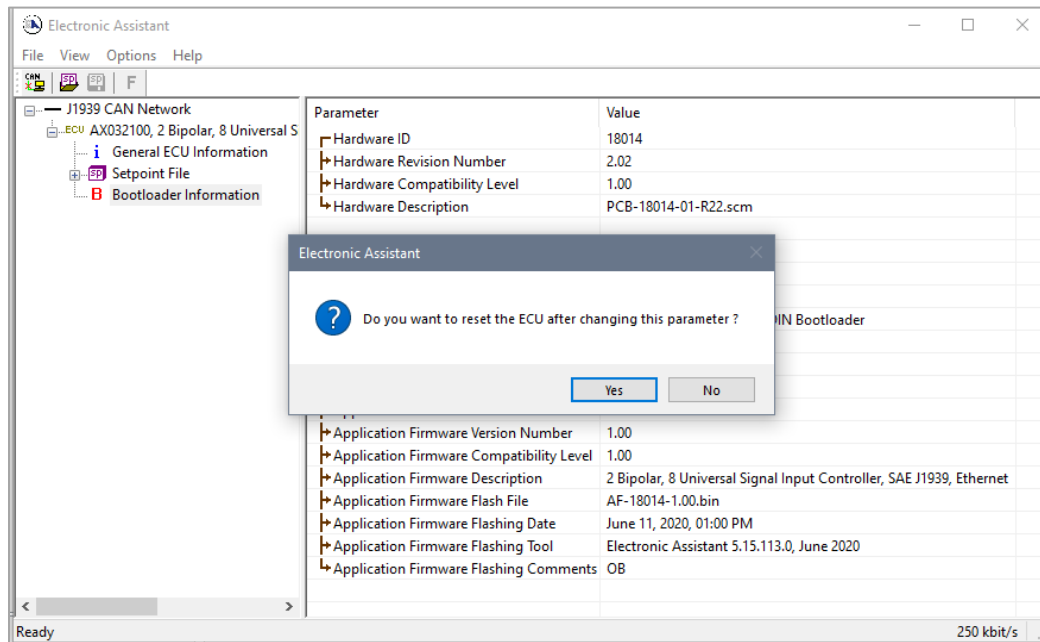

Figure 23. Bootloader Activation. Final Reset

All the bootloader specific information: controller hardware, bootloader details, and the currently installed application firmware remains the same in the bootloader mode and the user can read it in the *Bootloader Information* group screen, see Figure 24. The information can be slightly different for different versions of the bootloader.

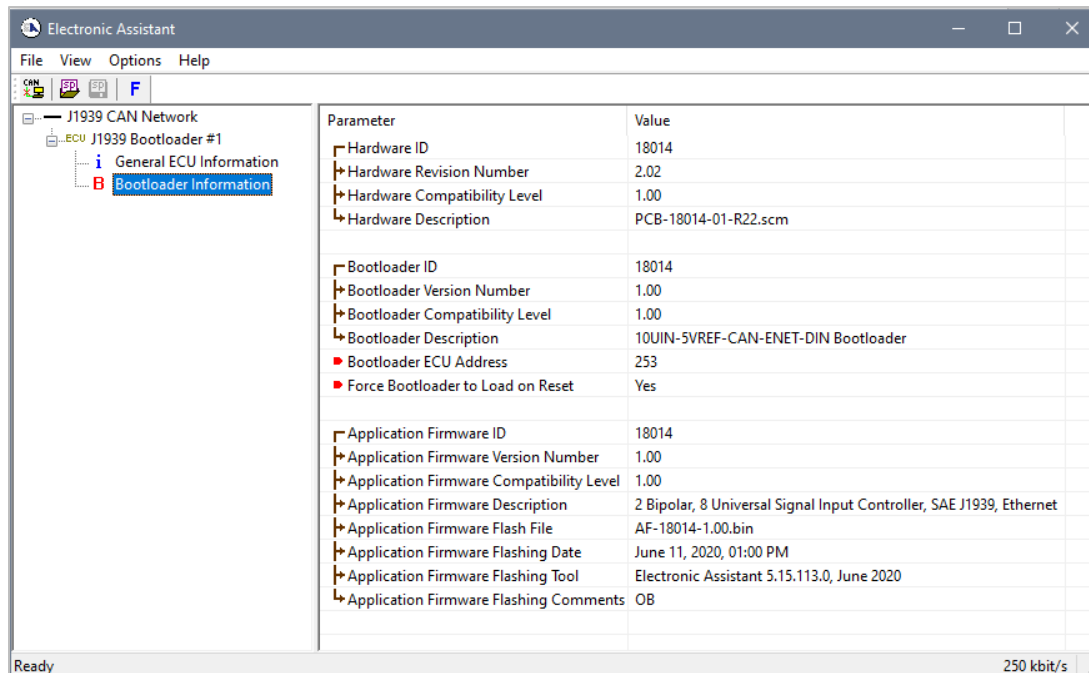

Figure 24. Bootloader Information Screen

At this point, the user can return to the installed controller firmware by changing the *Force Bootloader to Load on Reset* flag back to *No* and resetting the ECU.

To flash the new firmware, the user should click on **F** toolbar icon or from the *File* menu select the *Open Flash File* command. The *Open Application Firmware Flash File* dialog will appear. Pick up the flash file with the new converter firmware and confirm the selection by pressing the *Open* button. The *Flash Application Firmware* dialog window will appear¹, see Figure 25.

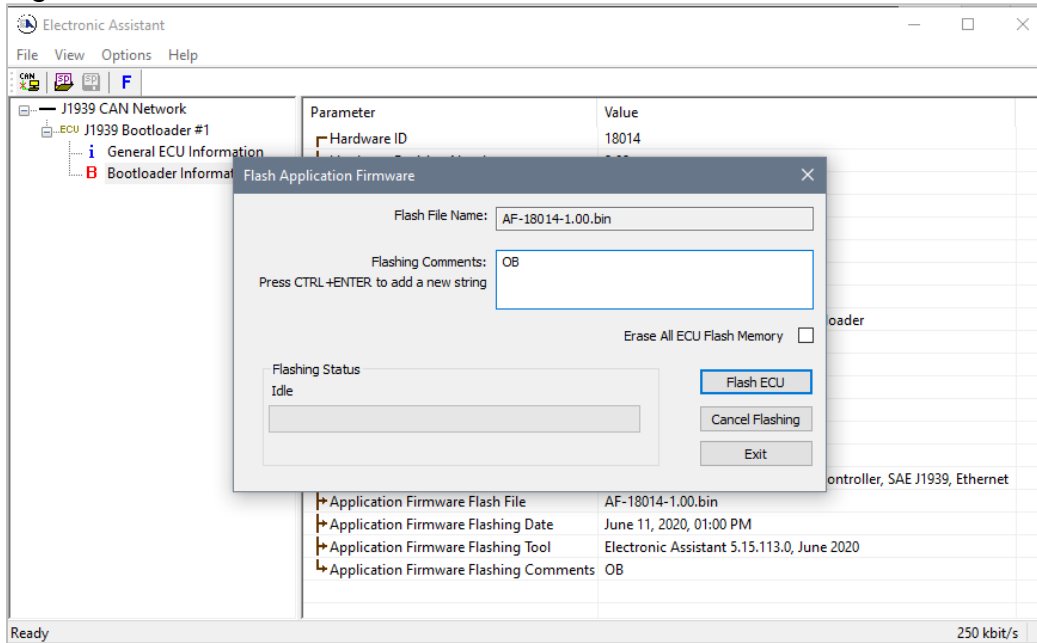

Figure 25. Flashing New Firmware. Preparation

¹ In this example, instead of the new firmware, the old firmware V1.00 is being simply re-flashed.

Now the user can add any comments to the flashing operation in the *Flashing Comments* field. They will be stored in the *Bootloader Information* group after flashing.

The user can also check the *Erase All ECU Flash Memory* flag to erase all inclinometer flash memory. This operation, used in other products to reset configuration parameters kept in the flash memory to their default values, has no effect on this product. This is because the configuration parameters of the inclinometer are stored in a separate EEPROM memory.

Select the *Flash ECU* button to start flashing. A reminder that the old application firmware will be destroyed by the flashing operation will appear. Press *Ok* to continue and watch the dynamics of the flashing operation in the *Flashing Status* field. When flashing is done, the following screen will appear prompting the user to reset the ECU, see Figure 26.

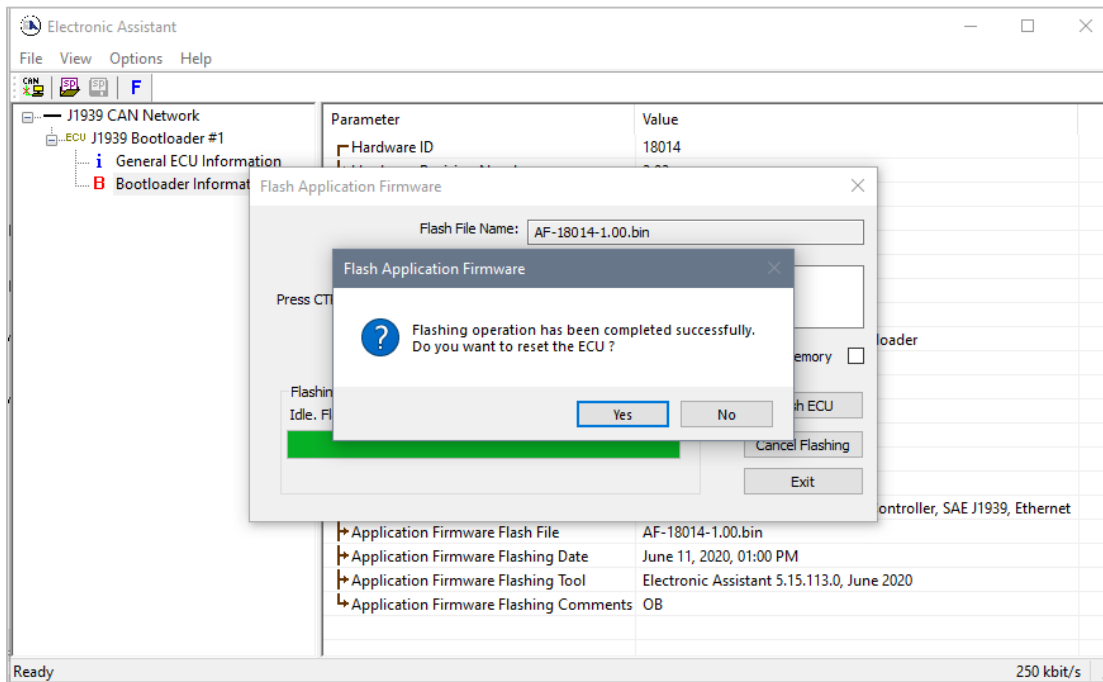

Figure 26. Flashing New Firmware. Final Reset.

Select Yes and see the ECU running the new firmware, see Figure 27. This will indicate that the flashing operation has been performed successfully.

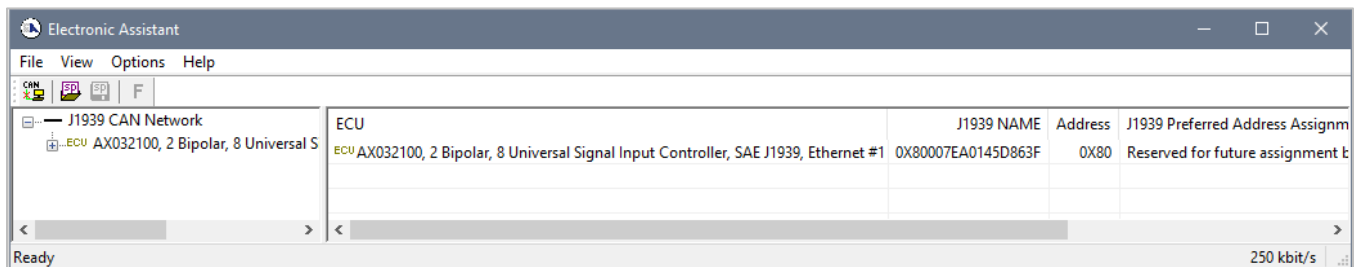

Figure 27. Firmware has been Updated. New Firmware Screen

For more information, see the *J1939 Bootloader* section of the EA user manual.

6 TECHNICAL SPECIFICATIONS

Stated at 25°C unless otherwise specified.

6.1 Power Supply

Table 34. Power Supply

Parameter	Value	Remarks
Supply Voltage	8...36 VDC	12V, 24V – nominal.
Supply Current	50 mA 100 mA	Typical at 24V. Typical at 12V.
Protection	Reverse polarity, Transients	

6.2 Bipolar Inputs

Table 35. Bipolar Inputs

Parameter	Value							
Analog Input Modes	Voltage, Current							
Voltage Input	Input Range	Input Impedance	Resolution	Accuracy				
	0...5V	1 MOhm ¹	<1.5mV	TBD				
	0...10V		<3 mV	TBD				
	-5...5V		<3 mV	TBD				
	-10...10V		<6 mV	TBD				
¹ 10kOhm LoZ option is available.								
Current Input	Input Range	Input Impedance	Resolution	Accuracy				
	0...20mA	124Ohm	<12uA	TBD				
	4...20mA							
Analog Update Rate	1.67ms minimum ¹ ¹ Depends on the analog filter settings							
Digital Input Modes	Discrete Voltage Level, Frequency, PWM Duty Cycle							
Input Polarity	Active High, Active Low							
Input Impedance	1MOhm – High Z, 10kOhm pull down, 10kOhm pull-up to +14V							
Input Level	5V CMOS Compatible. A direct connection to the power supply is acceptable.							
Discrete Voltage Level Input	1ms sampling rate. Configurable debouncing							
Frequency Input	Input Number	Counter Resolution	Frequency Range	Resolution ^{1,2}	Accuracy			
	Bipolar Input #1	32-bit	1Hz...10kHz	<0.0000012...0.012%	<0.01%			
			Bipolar Input #2			16-bit	100Hz...10kHz	<0.0017...0.17%
							10Hz...1kHz	
1Hz...100Hz								
PWM Duty Cycle Input	Input Number	Counter Resolution	Frequency Range	Resolution ^{1,2}	Accuracy			
	Bipolar Input #1	32-bit	1Hz...10kHz	<0.0000012...0.012%	TBD			
			Bipolar Input #2			16-bit	100Hz...10kHz	TBD
							10Hz...1kHz	
	1Hz...100Hz							

Parameter	Value
	0...100% Duty Cycle Range. DC is included.
Protection	+/-36V maximum. Forward and reverse polarity protection

¹ The relative resolution value is linearly proportional to the signal frequency: 0.0000012% at 100Hz and 0.012% at 10kHz for the 32-bit counter.

² Resolution can be affected by the debouncing filter settings.

6.3 Universal Inputs

Table 36. Universal Inputs

Parameter	Value				
Analog Input Modes	Voltage, Current, Resistance				
Voltage Input	Input Range	Input Impedance	Resolution	Accuracy	
	0...5V	>1M Ω (High Z) ¹	<1.5mV	TBD	
	0...10V	204k Ω ¹	<3 mV	TBD	
	¹ 10k Ω LoZ option is available.				
Current Input	Input Range	Input Impedance	Resolution	Accuracy	
	0...20mA	249 Ω	<12 μ A	TBD	
	4...20mA				
Resistance Input	Input Range	Resolution	Accuracy		
	Auto Range	–	–		
	10...250k Ω ^{1,2}				
	0...250 Ω ²	<0.15 Ω	TBD		
	0...2.5k Ω	<1.5 Ω	TBD		
	0...25k Ω	<15 Ω	TBD		
	0...250k Ω	<150 Ω	TBD		
¹ Resolution and accuracy depend on the automatically selected Input Range. ² Resistance <10 Ω is measured as 0.					
Analog Update Rate	1.67ms minimum ¹ . ¹ Depends on the analog filter settings. In resistive mode also depends on the number of resistive inputs.				
Digital Input Modes	Discrete Voltage Level, Frequency, PWM Duty Cycle				
Input Polarity	Active High, Active Low				
Input Impedance	>1M Ω – High Z, 10k Ω pull down, 10k Ω pull-up to +14V				
Input Level	5V CMOS Compatible. A direct connection to the power supply is acceptable.				
Discrete Voltage Level Input	1ms sampling rate. Configurable debouncing				
Frequency Input	Input Number	Counter Resolution	Frequency Range	Resolution ^{1,2}	Accuracy
	Universal Input #1...8	16-bit	100Hz...10kHz	<0.0017...0.17%	<0.01%
			10Hz...1kHz		
			1Hz...100Hz		

Parameter	Value				
PWM Duty Cycle Input	Input Number	Counter Resolution	Frequency Range	Resolution ^{1,2}	Accuracy
	Universal Input #1...8	16-bit	100Hz...10kHz	<0.0017...0.17%	TBD
			10Hz...1kHz		TBD
			1Hz...100Hz		TBD
0...100% Duty Cycle Range. DC is included.					
Protection	+36V maximum. Forward voltage only. No reverse polarity protection				

¹ The relative resolution value is linearly proportional to the signal frequency: 0.0017% at 100Hz and 0.17% at 10kHz for the 16-bit counter.

² Resolution can be affected by the debouncing filter settings.

6.4 Voltage Reference Outputs

Table 37. Voltage Reference Outputs

Parameter	Value	Remarks
Number of Outputs	2	
Output Voltage	+5V	
Voltage tolerance	1%	At 1mA
Supply Current	100mA	Nominal
Protection	Short circuit	Connection to the power supply is prohibited.

6.5 Ethernet Interface

Parameter	Value	Remarks
Number of Ports	1	Reading inputs, configuring the device.
Port Type	10BASE-T, 100BASE-TX	10 Mbit/s and 100Mbit/s Auto-configuration and full-duplex supported
MDIX	Auto-MDIX	Auto-crossover to eliminate cabling mismatch
LED Indicators	Speed/Link (Activity)	Yellow/Green
Protocols	Ethernet IEEE 802.3, IP, ICMP, ARP, UDP, TCP, Modbus TCP, Proprietary Discovery Protocol	Axiomatic Proprietary Discovery Protocol on port 35100
Modbus TCP/IP	Server mode (slave device). Supported Function codes:	
	2, 4	Reading Bipolar/Universal Inputs
	3, 6, 16, 23	Reading/Changing configuration parameters
	43/14	Reading controller ID, S/N on a private object 0x80
		Up to 8 simultaneous client connections

6.6 CAN Interface

Table 38. CAN Parameters

Parameter	Value	Remarks
Number of Ports	1	Reading inputs, configuring the device, updating firmware
LED Indicator	Error/Link (Activity)	Red/Green

Parameter	Value	Remarks
Communication Standards	SAE J1939	Full support for J1939 ECU. User-configurable PGNs.
	Baud Rate	250, 500, 667kbit/s, 1Mbit/s. Automatic baud rate detection
	ISO 11898	120Ohm terminated twisted pair, baud rate up to 1Mbit/s. External 120Ohm termination is required.
	Bosch CAN protocol specification 2.0, Part A, B.	For the internal CAN controller.
Protection	Short circuit to ground	
	Connection to the power supply	Only for 12V systems, 24V max.

6.7 General Specifications

Table 39. General Specifications

Parameter	Value	Remarks	
Internal Logic	User-Configurable	Interface	
		J1939 CAN	Axiomatic Electronic Assistant®, P/N: AX070502
		Modbus TCP	Third-party software
Firmware Update	In-system, through J1939 CAN	Axiomatic Electronic Assistant®, P/N: AX070502. Modbus TCP – currently not supported	
LED Indicators	CAN/System	Red/Green – CAN or System error/CAN link(activity). Flashing green/red– bootloader mode.	
	Ethernet	Yellow/Green – Ethernet speed/link(activity)	
Operating Temperature	-40...+85 °C	Industrial temperature range	
Environmental Protection	IP20	EN 60259	
Housing	Phoenix Contact ME MAX 22,5 G 2-2 KMGY - 2713638	Polyamide, Flammability V0 UL94, UL Recognized, EAC, China RoHS	
Electrical Connectors	Phoenix Contact MCO 1,5/5-G1L-3,5 - 2278380	J3 (Power/CAN/Ref#1), J5 (Bi/Univ Inputs)	
	Phoenix Contact MCO 1,5/5-G1R-3,5 - 2278351	J4 (Univ Inputs), J6 (Univ Inputs/Ref#2)	
	RJ-45	Ethernet, CAT5 (IEC 11801:2002)	
Installation	DIN Rail TH35-7.5 or TH35-15	EN 60715. Mounting Rail: 35 x 7.5mm or 35 x 15mm.	
Size	114.5 x 22.5 x 99 mm (4.508 x 0.89 x 3.898 in)	L(D) x W x H. See dimensional drawing	
	107 mm (4.213 in)	Depth from the top edge of DIN rail. See dimensional drawing	
Weight	0.136 kg (0.30 lb)		
Compliance	CE mark (pending) RoHS Directive		

6.8 Enclosure

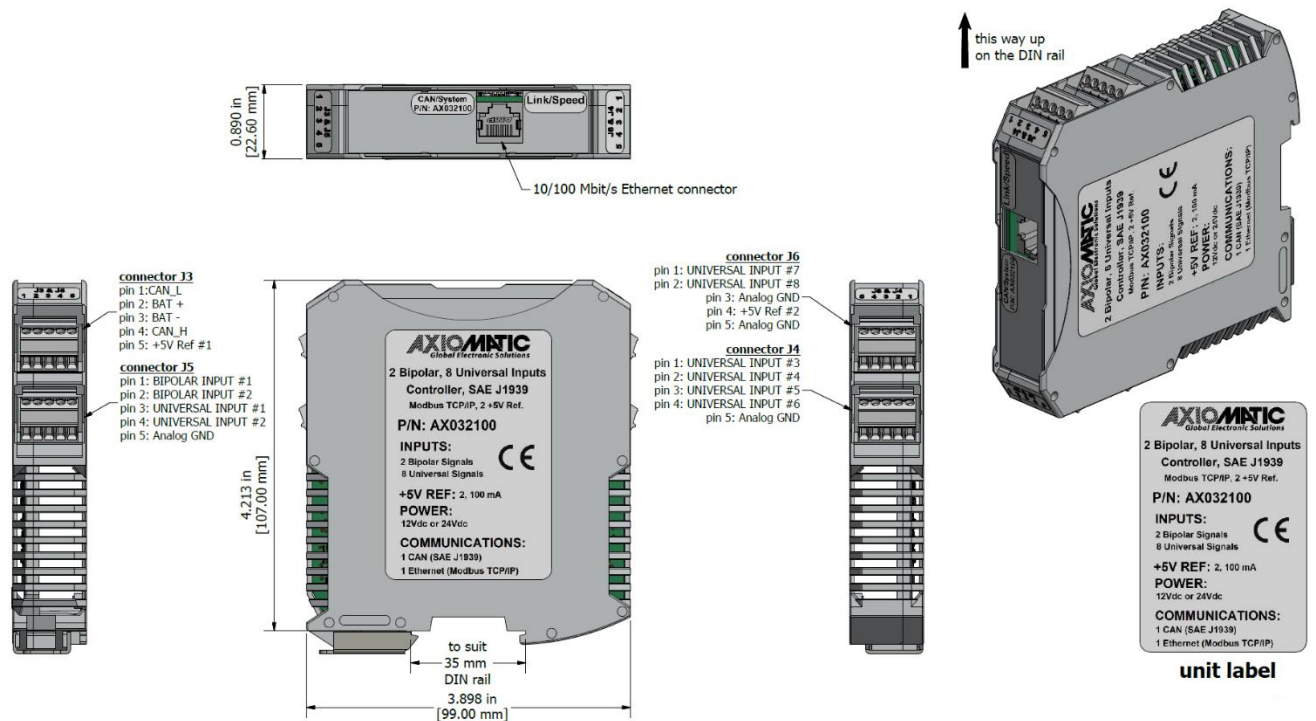

Figure 28. Dimensional Drawing

6.9 Electrical Connections

The controller has four 5-pin electrical connectors (except Ethernet) with the following pinouts.

Table 40. Connector Pinouts

Connector Pin Number	Connector Name			
	J3 (Power/CAN/Ref#1)	J5 (Bi/Univ Inputs)	J4 (Univ Inputs)	J6 (Univ Inputs/Ref#2)
1	CAN_L	Bipolar Input #1	Universal Input #3	Universal Input #7
2	BAT+	Bipolar Input #2	Universal Input #4	Universal Input #8
3	BAT-	Universal Input #1	Universal Input #5	Analog GND
4	CAN_H	Universal Input #2	Universal Input #6	+5V Ref #2
5	+5V Ref #1	Analog GND	Analog GND	Analog GND

Recommended mating connectors for J3...J6 are 5-pin 3.5 mm Phoenix Contact MC 1,5/5-ST-3,5 GY7035 – 1769087 screw terminal connectors with tension sleeves. They accept 28-16 AWG wires. A standard RJ-45 CAT5 or better plug can be used as a mating Ethernet connector.

6.10 Installation

For mechanical installation see information on the dimensional drawing. The CAN bus should be terminated on both sides with 120 Ohm resistors (0.25W minimum, metal film or similar type) between CAN_H and CAN_L.

7 MODBUS ADDRESS MAP

The following Modbus Address Map is used for the Modbus TCP communication with the controller.

Table 41. Modbus Address Map

Bit/Reg Address	Modbus Address		# of Reg	Name	Format	Default	Range	Units or Res.	Access	Description
	Dec	Hex								
Input Section										
Discrete Inputs										
101025	1024	0x0400	N/A	Bipolar Input #1	Bit	N/A	0...1	State	RO	
101026	1025	0x0401	N/A	Bipolar Input #2	Bit	N/A	0...1	State	RO	
101027	1026	0x0402	N/A	Universal Input #1	Bit	N/A	0...1	State	RO	
101028	1027	0x0403	N/A	Universal Input #2	Bit	N/A	0...1	State	RO	
101029	1028	0x0404	N/A	Universal Input #3	Bit	N/A	0...1	State	RO	
101030	1029	0x0405	N/A	Universal Input #4	Bit	N/A	0...1	State	RO	
101031	1030	0x0406	N/A	Universal Input #5	Bit	N/A	0...1	State	RO	
101032	1031	0x0407	N/A	Universal Input #6	Bit	N/A	0...1	State	RO	
101033	1032	0x0408	N/A	Universal Input #7	Bit	N/A	0...1	State	RO	
101034	1033	0x0409	N/A	Universal Input #8	Bit	N/A	0...1	State	RO	
Discrete Inputs										
301025	1024	0x0400	1	Discrete Inputs	Bits	N/A	0...0x3ff	1 bit per input	RO	Bit 0 (LSB) - Bipolar Input #1, Bit 1 -Bipolar Input #2, Bit 2 - Universal Input #1, ... Bit 9 - Universal Input #8. When an input is not in "Discrete Voltage Level" mode, the input state is 0.
Bipolar/Universal Inputs										
301026	1025	0x0401	2	Bipolar Input #1	Float	N/A	See input config	See config	RO	
301028	1027	0x0403	2	Bipolar Input #2	Float	N/A	See input config	See config	RO	
301030	1029	0x0405	2	Universal Input #1	Float	N/A	See input config	See config	RO	

Bit/Reg Address	Modbus Address		# of Reg	Name	Format	Default	Range	Units or Res.	Access	Description
	Dec	Hex								
301032	1031	0x0407	2	Universal Input #2	Float	N/A	See input config	See config	RO	
301034	1033	0x0409	2	Universal Input #3	Float	N/A	See input config	See config	RO	
301036	1035	0x040B	2	Universal Input #4	Float	N/A	See input config	See config	RO	
301038	1037	0x040D	2	Universal Input #5	Float	N/A	See input config	See config	RO	
301040	1039	0x040F	2	Universal Input #6	Float	N/A	See input config	See config	RO	
301042	1041	0x0411	2	Universal Input #7	Float	N/A	See input config	See config	RO	
301044	1043	0x0413	2	Universal Input #8	Float	N/A	See input config	See config	RO	
301046	1045	0x0415	11	Reserved	N/A	N/A	N/A	N/A	RO	Reserved for future use. Reading results in 0
Binary Function Outputs										
301057	1056	0x0420	2	Binary Function Output #1	Float	N/A	N/A	N/A	RO	
301059	1058	0x0422	2	Binary Function Output #2	Float	N/A	N/A	N/A	RO	
301061	1060	0x0424	2	Binary Function Output #3	Float	N/A	N/A	N/A	RO	
301063	1062	0x0426	2	Binary Function Output #4	Float	N/A	N/A	N/A	RO	
301065	1064	0x0428	2	Binary Function Output #5	Float	N/A	N/A	N/A	RO	
301067	1066	0x042A	2	Binary Function Output #6	Float	N/A	N/A	N/A	RO	
301069	1068	0x042C	2	Binary Function Output #7	Float	N/A	N/A	N/A	RO	
301071	1070	0x042E	2	Binary Function Output #8	Float	N/A	N/A	N/A	RO	
301073	1072	0x0430	2	Binary Function Output #9	Float	N/A	N/A	N/A	RO	
301075	1074	0x0432	2	Binary Function Output #10	Float	N/A	N/A	N/A	RO	

Bit/Reg Address	Modbus Address		# of Reg	Name	Format	Default	Range	Units or Res.	Access	Description
	Dec	Hex								
301077	1076	0x0434	12	Reserved	N/A	N/A	N/A	N/A	RO	Reserved for future use. Reading results in 0
CAN Inputs										
301089	1088	0x0440	2	CAN Input Signal #1	Float	N/A	See input config	See In config	RO	
301091	1090	0x0442	2	CAN Input Signal #2	Float	N/A	See input config	See In config	RO	
301093	1092	0x0444	2	CAN Input Signal #3	Float	N/A	See input config	See In config	RO	
301095	1094	0x0446	10	Reserved	N/A	N/A	N/A	N/A	RO	Reserved for future use. Reading results in 0
Auxiliary Signals										
301105	1104	0x0450	2	Global Discrete Constant Signal	Dword	N/A	N/A	N/A	RO	Equals to the <i>Global Discrete Constant Signal</i> configuration parameter
301107	1106	0x0452	2	Global Continuous Constant Signal	Float	N/A	N/A	N/A	RO	Equals to the <i>Global Continuous Constant Signal</i> configuration parameter
301109	1108	0x0454	2	Global Constant Signal = 0	Float	N/A	N/A	N/A	RO	Equals to zero
301111	1110	0x0456	2	Global Constant Signal = 1	Float	N/A	N/A	N/A	RO	Equals to one
301113	1112	0x0458	2	Supply Voltage	Float	N/A	Not Rated	V	RO	Covers rated supply voltage range
301115	1114	0x045A	2	Microcontroller Temperature	Float	N/A	Not Rated	Deg.C	RO	Covers rated temperature range
301117	1116	0x045C	4	Reserved	N/A	N/A	N/A	N/A	RO	Reserved for future use. Reading results in 0
Configuration Section										
Bipolar Input #1										
401025	1024	0x0400	1	Input Parameter	Byte	1 - Voltage	0 - Input Disabled, 1 - Voltage,	N/A	R/W	Defines the input parameter that will be measured by the input.

Bit/Reg Address	Modbus Address		# of Reg	Name	Format	Default	Range	Units or Res.	Access	Description
	Dec	Hex								
							2 - Current, 3 - Resistance (not used), 4 - Discrete Voltage Level, 5 - Frequency, 6 - PWM Duty Cycle			"Resistance" is not used. Writing "Resistance" will disable the input.
401026	1025	0x0401	1	Voltage Range	Byte	0 - 0...5V	0 - 0...5 V, 1 - 0...10 V, 2 - -5...5 V, 3 - -10...10 V	V	R/W	Used when Input Parameter is "Voltage"
401027	1026	0x0402	1	Current Range	Byte	0 - 0...20 mA	0 - 0...20mA, 1 - 4...20 mA	mA	R/W	Used when Input Parameter is "Current"
401028	1027	0x0403	1	Resistance Range	Byte	0	0	N/A	RO	Not used in Bipolar Inputs. Reading will always return 0, writing is allowed, but does not change the value.
401029	1028	0x0404	1	Voltage LoZ Input	Byte	0 - No	0 - No, 1 - Yes	N/A	R/W	Activates a 10kOhm pull-down resistor to avoid ghost voltages in the "Voltage" mode. Warning: Measurement accuracy will be decreased!
401030	1029	0x0405	1	Analog Input Filter	Byte	0 - Disabled	0 - Disabled, 1 - 50Hz Noise Rejection, 2 - 60Hz Noise Rejection, 3 - Both: 60Hz and 50Hz Noise Rejection	N/A	R/W	Noise Rejection in "Voltage" and "Current" mode.
401031	1030	0x0406	1	Pull-Up/Pull-Down Resistor	Byte	0 - Disabled	0 - Disabled, 1 - 10kOhm Pull-Up,	N/A	R/W	Used in "Discrete Voltage Level", "Frequency", and

Bit/Reg Address	Modbus Address		# of Reg	Name	Format	Default	Range	Units or Res.	Access	Description
	Dec	Hex								
							2 - 10kOhm Pull-Down			"PWM Duty Cycle" modes.
401032	1031	0x0407	1	Input Polarity	Byte	0 - Active High	0 - Active High, 1 - Active Low	N/A	R/W	Used in "Discrete Voltage Level", "Frequency", and "PWM Duty Cycle" modes.
401033	1032	0x0408	1	Discrete Input Debounce Time	Word	50ms	0...1000ms	ms	R/W	Used in "Discrete Voltage Level". If 0 - no debouncing.
401034	1033	0x0409	1	Frequency Range	Byte	0 - 1Hz...10kHz	0 - 1Hz...10kHz	Hz	R/W	One extended range is available due to 32bit counter. Used in "Frequency", and "PWM Duty Cycle" modes.
401035	1034	0x040A	1	Frequency/PWM Debounce Filter	Byte	0 - Disabled	0 - Disabled, 1 - 142ns, 2 - 1.14us, 3 - 6.10us	N/A	R/W	Used in "Frequency", and "PWM Duty Cycle" modes.
401036	1035	0x040B	1	Frequency/PWM Averaging	Byte	0 - No Averaging	0 - No Averaging, 1 - 3 Readings, 2 - 5 Readings, 3 - 10 Readings	N/A	R/W	Defines a moving average filter used in "Frequency", and "PWM Duty Cycle" modes.
401037	1036	0x040C	20	Reserved	N/A	N/A	N/A	N/A	RO	Reserved for future use. Reading results in 0. Writing is allowed but does not change the value.
Bipolar Input #2										
401057	1056	0x0420	1	Input Parameter	Byte	1 - Voltage	0 - Input Disabled, 1 - Voltage, 2 - Current, 3 -Resistance (not used), 4 - Discrete Voltage Level,	N/A	R/W	Defines the input parameter that will be measured by the input. "Resistance" is not used. Writing "Resistance" will disable the input.

Bit/Reg Address	Modbus Address		# of Reg	Name	Format	Default	Range	Units or Res.	Access	Description
	Dec	Hex								
							5 - Frequency, 6 - PWM Duty Cycle			
401058	1057	0x0421	1	Voltage Range	Byte	0 - 0...5V	0 - 0...5 V, 1 - 0...10 V, 2 - -5...5 V, 3 - -10...10 V	V	R/W	Used when Input Parameter is "Voltage"
401059	1058	0x0422	1	Current Range	Byte	0 - 0...20 mA	0 - 0...20mA, 1 - 4...20 mA	mA	R/W	Used when Input Parameter is "Current"
401060	1059	0x0423	1	Resistance Range	Byte	0	0	N/A	RO	Not used in Bipolar Inputs. Reading will always return 0, writing is allowed, but does not change the value.
401061	1060	0x0424	1	Voltage LoZ Input	Byte	0 - No	0 - No, 1 - Yes	N/A	R/W	Activates a 10kOhm pull-down resistor to avoid ghost voltages in the "Voltage" mode. Warning: Measurement accuracy will be decreased!
401062	1061	0x0425	1	Analog Input Filter	Byte	0 - Disabled	0 - Disabled, 1 - 50Hz Noise Rejection, 2 - 60Hz Noise Rejection, 3 - Both: 60Hz and 50Hz Noise Rejection	N/A	R/W	Noise Rejection in "Voltage" and "Current" modes.
401063	1062	0x0426	1	Pull-Up/Pull-Down Resistor	Byte	0 - Disabled	0 - Disabled, 1 - 10kOhm Pull-Up, 2 - 10 kOhm Pull-Down	N/A	R/W	Used in "Discrete Voltage Level", "Frequency", and "PWM Duty Cycle" modes.
401064	1063	0x0427	1	Input Polarity	Byte	0 - Active High	0 - Active High, 1 - Active Low	N/A	R/W	Used in "Discrete Voltage Level", "Frequency", and

Bit/Reg Address	Modbus Address		# of Reg	Name	Format	Default	Range	Units or Res.	Access	Description
	Dec	Hex								
										"PWM Duty Cycle" modes.
401065	1064	0x0428	1	Discrete Input Debounce Time	Word	50	0...1000ms	ms	R/W	Used in "Discrete Voltage Level". If 0 - no debouncing.
401066	1065	0x0429	1	Frequency Range	Byte	0 - 100Hz...10kHz	0 - 100Hz...10kHz, 1 - 10Hz...1kHz, 2 - 1Hz...100Hz	Hz	RO	A 16-bit shared counter is used. The parameter is configured in Universal Input #3. Writing is allowed but does not change the value. Used in "Frequency", and "PWM Duty Cycle" modes.
401067	1066	0x042A	1	Frequency/PWM Debounce Filter	Byte	0 - Disabled	0 - Disabled, 1 - 142ns, 2 - 1.14us, 3 - 6.10us	N/A	RO	The parameter is configured in Universal Input #3. Writing is allowed but does not change the value. Used in "Frequency", and "PWM Duty Cycle" modes.
401068	1067	0x042B	1	Frequency/PWM Averaging	Byte	0 - No Averaging	0 - No Averaging, 1 - 3 Readings, 2 - 5 Readings, 3 - 10 Readings	N/A	R/W	Defines a moving average filter. Used in "Frequency", and "PWM Duty Cycle" modes.
401069	1068	0x042C	20	Reserved	N/A	N/A	N/A	N/A	RO	Reserved for future use. Reading results in 0. Writing is allowed but does not change the value.
Universal Input #1										
401089	1088	0x0440	1	Input Parameter	Byte	1 - Voltage	0 - Input Disabled, 1 - Voltage, 2 - Current,	N/A	R/W	Defines the input parameter that will be measured by the input.

Bit/Reg Address	Modbus Address		# of Reg	Name	Format	Default	Range	Units or Res.	Access	Description
	Dec	Hex								
							3 - Resistance, 4 - Discrete Voltage Level, 5 - Frequency, 6 - PWM Duty Cycle			
401090	1089	0x0441	1	Voltage Range	Byte	0 - 0...5V	0 - 0...5 V, 1 - 0...10 V	V	R/W	Used when Input Parameter is "Voltage"
401091	1090	0x0442	1	Current Range	Byte	0 - 0...20 mA	0 - 0...20mA, 1 - 4...20 mA	mA	R/W	Used when Input Parameter is "Current"
401092	1091	0x0443	1	Resistance Range	Byte	0 - Auto Range	0 - Auto Range, 1 - 0...250Ohm, 2 - 0...2.5kOhm, 3 - 0...25kOhm, 4 - 0...250kOhm	Ohm	R/W	Used when Input Parameter is "Resistance"
401093	1092	0x0444	1	Voltage LoZ Input	Byte	0 - No	0 - No, 1 - Yes	N/A	R/W	Activates a 10kOhm pull-down resistor to avoid ghost voltages in the "Voltage" mode. Warning: Measurement accuracy will be decreased!
401094	1093	0x0445	1	Analog Input Filter	Byte	0 - Disabled	0 - Disabled, 1 - 50Hz Noise Rejection, 2 - 60Hz Noise Rejection, 3 - Both: 60Hz and 50Hz Noise Rejection	N/A	R/W	Noise Rejection in "Voltage", "Current" and "Resistance" modes.
401095	1094	0x0446	1	Pull-Up/Pull-Down Resistor	Byte	0 - Disabled	0 - Disabled, 1 - 10kOhm Pull-Up, 2 - 10 kOhm Pull-Down	N/A	R/W	Used in "Discrete Voltage Level", "Frequency", and "PWM Duty Cycle" modes.
401096	1095	0x0447	1	Input Polarity	Byte	0 - Active High	0 - Active High, 1 - Active Low	N/A	R/W	Used in "Discrete Voltage Level", "Frequency", and

Bit/Reg Address	Modbus Address		# of Reg	Name	Format	Default	Range	Units or Res.	Access	Description
	Dec	Hex								
										"PWM Duty Cycle" modes.
401097	1096	0x0448	1	Discrete Input Debounce Time	Word	50	0...1000ms	ms	R/W	Used in "Discrete Voltage Level". If 0 - no debouncing.
401098	1097	0x0449	1	Frequency Range	Byte	0 - 100Hz...10kHz	0 - 100Hz...10kHz, 1 - 10Hz...1kHz, 2 - 1Hz...100Hz	Hz	R/W	A 16-bit counter is shared with Universal Input #8. Used in "Frequency", and "PWM Duty Cycle" modes.
401099	1098	0x044A	1	Frequency/PWM Debounce Filter	Byte	0 - Disabled	0 - Disabled, 1 - 142ns, 2 - 1.14us, 3 - 6.10us	N/A	R/W	Shared with Universal Input #8. Used in "Frequency", and "PWM Duty Cycle" modes.
401100	1099	0x044B	1	Frequency/PWM Averaging	Byte	0 - No Averaging	0 - No Averaging, 1 - 3 Readings, 2 - 5 Readings, 3 - 10 Readings	N/A	R/W	Defines a moving average filter. Used in "Frequency", and "PWM Duty Cycle" modes.
401101	1100	0x044C	20	Reserved	N/A	N/A	N/A	N/A	RO	Reserved for future use. Reading results in 0. Writing is allowed but does not change the value.
Universal Input #2										
401121	1120	0x0460	1	Input Parameter	Byte	1 - Voltage	0 - Input Disabled, 1 - Voltage, 2 - Current, 3 -Resistance, 4 - Discrete Voltage Level, 5 - Frequency, 6 - PWM Duty Cycle	N/A	R/W	Defines the input parameter that will be measured by the input.
401122	1121	0x0461	1	Voltage Range	Byte	0 - 0...5V	0 - 0...5 V, 1 - 0...10 V	V	R/W	Used when Input Parameter is "Voltage"

Bit/Reg Address	Modbus Address		# of Reg	Name	Format	Default	Range	Units or Res.	Access	Description
	Dec	Hex								
401123	1122	0x0462	1	Current Range	Byte	0 - 0...20 mA	0 - 0...20mA, 1 - 4...20 mA	mA	R/W	Used when Input Parameter is "Current"
401124	1123	0x0463	1	Resistance Range	Byte	0 - Auto Range	0 - Auto Range, 1 -0...250Ohm, 2-0...2.5kOhm, 3- 0...25kOhm, 4-0...250kOhm	Ohm	R/W	Used when Input Parameter is "Resistance"
401125	1124	0x0464	1	Voltage LoZ Input	Byte	0 - No	0 - No, 1 - Yes	N/A	R/W	Activates a 10kOhm pull-down resistor to avoid ghost voltages in the "Voltage" mode. Warning: Measurement accuracy will be decreased!
401126	1125	0x0465	1	Analog Input Filter	Byte	0 - Disabled	0 - Disabled, 1 - 50Hz Noise Rejection, 2 - 60Hz Noise Rejection, 3 - Both: 60Hz and 50Hz Noise Rejection	N/A	R/W	Noise Rejection in "Voltage", "Current" and "Resistance" modes.
401127	1126	0x0466	1	Pull-Up/Pull-Down Resistor	Byte	0 - Disabled	0 - Disabled, 1 - 10kOhm Pull-Up, 2 - 10 kOhm Pull-Down	N/A	R/W	Used in "Discrete Voltage Level", "Frequency", and "PWM Duty Cycle" modes.
401128	1127	0x0467	1	Input Polarity	Byte	0 - Active High	0 - Active High, 1 - Active Low	N/A	R/W	Used in "Discrete Voltage Level", "Frequency", and "PWM Duty Cycle" modes.
401129	1128	0x0468	1	Discrete Input Debounce Time	Word	50	0...1000ms	ms	R/W	Used in "Discrete Voltage Level". If 0 - no debouncing.
401130	1129	0x0469	1	Frequency Range	Byte	0 - 100Hz...10kHz	0 - 100Hz...10kHz, 1 - 10Hz...1kHz, 2 - 1Hz...100Hz	Hz	R/W	A 16-bit counter is shared with Universal Input #5. Used in "Frequency",

Bit/Reg Address	Modbus Address		# of Reg	Name	Format	Default	Range	Units or Res.	Access	Description
	Dec	Hex								
										and "PWM Duty Cycle" modes.
401131	1130	0x046A	1	Frequency/PWM Debounce Filter	Byte	0 - Disabled	0 - Disabled, 1 - 142ns, 2 - 1.14us, 3 - 6.10us	N/A	R/W	Shared with Universal Input #5. Used in "Frequency", and "PWM Duty Cycle" modes.
401132	1131	0x046B	1	Frequency/PWM Averaging	Byte	0 - No Averaging	0 - No Averaging, 1 - 3 Readings, 2 - 5 Readings, 3 - 10 Readings	N/A	R/W	Defines a moving average filter. Used in "Frequency", and "PWM Duty Cycle" modes.
401133	1132	0x046C	20	Reserved	N/A	N/A	N/A	N/A	RO	Reserved for future use. Reading results in 0. Writing is allowed, but does not change the value.
Universal Input #3										
401153	1152	0x0480	1	Input Parameter	Byte	1 - Voltage	0 - Input Disabled, 1 - Voltage, 2 - Current, 3 -Resistance, 4 - Discrete Voltage Level, 5 - Frequency, 6 - PWM Duty Cycle	N/A	R/W	Defines the input parameter that will be measured by the input.
401154	1153	0x0481	1	Voltage Range	Byte	0 - 0...5V	0 - 0...5 V, 1 - 0...10 V	V	R/W	Used when Input Parameter is "Voltage"
401155	1154	0x0482	1	Current Range	Byte	0 - 0...20 mA	0 - 0...20mA, 1 - 4...20 mA	mA	R/W	Used when Input Parameter is "Current"
401156	1155	0x0483	1	Resistance Range	Byte	0 - Auto Range	0 - Auto Range, 1 -0...250Ohm, 2-0...2.5kOhm, 3- 0...25kOhm, 4-0...250kOhm	Ohm	R/W	Used when Input Parameter is "Resistance"
401157	1156	0x0484	1	Voltage LoZ Input	Byte	0 - No	0 - No, 1 - Yes	N/A	R/W	Activates a 10kOhm pull-down resistor to

Bit/Reg Address	Modbus Address		# of Reg	Name	Format	Default	Range	Units or Res.	Access	Description
	Dec	Hex								
										avoid ghost voltages in the "Voltage" mode. Warning: Measurement accuracy will be decreased!
401158	1157	0x0485	1	Analog Input Filter	Byte	0 - Disabled	0 - Disabled, 1 - 50Hz Noise Rejection, 2 - 60Hz Noise Rejection, 3 - Both: 60Hz and 50Hz Noise Rejection	N/A	R/W	Noise Rejection in "Voltage", "Current" and "Resistance" modes.
401159	1158	0x0486	1	Pull-Up/Pull-Down Resistor	Byte	0 - Disabled	0 - Disabled, 1 - 10kOhm Pull-Up, 2 - 10 kOhm Pull-Down	N/A	R/W	Used in "Discrete Voltage Level", "Frequency", and "PWM Duty Cycle" modes.
401160	1159	0x0487	1	Input Polarity	Byte	0 - Active High	0 - Active High, 1 - Active Low	N/A	R/W	Used in "Discrete Voltage Level", "Frequency", and "PWM Duty Cycle" modes.
401161	1160	0x0488	1	Discrete Input Debounce Time	Word	50	0...1000ms	ms	R/W	Used in "Discrete Voltage Level". If 0 - no debouncing.
401162	1161	0x0489	1	Frequency Range	Byte	0 - 100Hz...10kHz	0 - 100Hz...10kHz, 1 - 10Hz...1kHz, 2 - 1Hz...100Hz	Hz	R/W	A 16-bit counter is shared with Bipolar Input #2. Used in "Frequency", and "PWM Duty Cycle" modes.
401163	1162	0x048A	1	Frequency/PWM Debounce Filter	Byte	0 - Disabled	0 - Disabled, 1 - 142ns, 2 - 1.14us, 3 - 6.10us	N/A	R/W	Shared with Bipolar Input #2. Used in "Frequency", and "PWM Duty Cycle" modes.
401164	1163	0x048B	1	Frequency/PWM Averaging	Byte	0 - No Averaging	0 - No Averaging, 1 - 3 Readings,	N/A	R/W	Defines a moving average filter.

Bit/Reg Address	Modbus Address		# of Reg	Name	Format	Default	Range	Units or Res.	Access	Description
	Dec	Hex								
							2 - 5 Readings, 3 - 10 Readings			Used in "Frequency", and "PWM Duty Cycle" modes.
401165	1164	0x048C	20	Reserved	N/A	N/A	N/A	N/A	RO	Reserved for future use. Reading results in 0. Writing is allowed but does not change the value.
Universal Input #4										
401185	1184	0x04A0	1	Input Parameter	Byte	1 - Voltage	0 - Input Disabled, 1 - Voltage, 2 - Current, 3 -Resistance, 4 - Discrete Voltage Level, 5 - Frequency, 6 - PWM Duty Cycle	N/A	R/W	Defines the input parameter that will be measured by the input.
401186	1185	0x04A1	1	Voltage Range	Byte	0 - 0...5V	0 - 0...5 V, 1 - 0...10 V	V	R/W	Used when Input Parameter is "Voltage"
401187	1186	0x04A2	1	Current Range	Byte	0 - 0...20 mA	0 - 0...20mA, 1 - 4...20 mA	mA	R/W	Used when Input Parameter is "Current"
401188	1187	0x04A3	1	Resistance Range	Byte	0 - Auto Range	0 - Auto Range, 1 -0...250Ohm, 2-0...2.5kOhm, 3-0...25kOhm, 4-0...250kOhm	Ohm	R/W	Used when Input Parameter is "Resistance"
401189	1188	0x04A4	1	Voltage LoZ Input	Byte	0 - No	0 - No, 1 - Yes	N/A	R/W	Activates a 10kOhm pull-down resistor to avoid ghost voltages in the "Voltage" mode. Warning: Measurement accuracy will be decreased!
401190	1189	0x04A5	1	Analog Input Filter	Byte	0 - Disabled	0 - Disabled, 1 - 50Hz Noise Rejection, 2 - 60Hz Noise	N/A	R/W	Noise Rejection in "Voltage", "Current" and "Resistance" modes.

Bit/Reg Address	Modbus Address		# of Reg	Name	Format	Default	Range	Units or Res.	Access	Description
	Dec	Hex								
							Rejection, 3 - Both: 60Hz and 50Hz Noise Rejection			
401191	1190	0x04A6	1	Pull-Up/Pull-Down Resistor	Byte	0 - Disabled	0 - Disabled, 1 - 10kOhm Pull-Up, 2 - 10 kOhm Pull-Down	N/A	R/W	Used in "Discrete Voltage Level", "Frequency", and "PWM Duty Cycle" modes.
401192	1191	0x04A7	1	Input Polarity	Byte	0 - Active High	0 - Active High, 1 - Active Low	N/A	R/W	Used in "Discrete Voltage Level", "Frequency", and "PWM Duty Cycle" modes.
401193	1192	0x04A8	1	Discrete Input Debounce Time	Word	50	0...1000ms	ms	R/W	Used in "Discrete Voltage Level". If 0 - no debouncing.
401194	1193	0x04A9	1	Frequency Range	Byte	0 - 100Hz...10kHz	0 - 100Hz...10kHz, 1 - 10Hz...1kHz, 2 - 1Hz...100Hz	Hz	R/W	A 16-bit counter is used. Used in "Frequency", and "PWM Duty Cycle" modes.
401195	1194	0x04AA	1	Frequency/PWM Debounce Filter	Byte	0 - Disabled	0 - Disabled, 1 - 142ns, 2 - 1.14us, 3 - 6.10us	N/A	R/W	Used in "Frequency", and "PWM Duty Cycle" modes.
401196	1195	0x04AB	1	Frequency/PWM Averaging	Byte	0 - No Averaging	0 - No Averaging, 1 - 3 Readings, 2 - 5 Readings, 3 - 10 Readings	N/A	R/W	Defines a moving average filter. Used in "Frequency", and "PWM Duty Cycle" modes.
401197	1196	0x04AC	20	Reserved	N/A	N/A	N/A	N/A	RO	Reserved for future use. Reading results in 0. Writing is allowed but does not change the value.

Universal Input #5

Bit/Reg Address	Modbus Address		# of Reg	Name	Format	Default	Range	Units or Res.	Access	Description
	Dec	Hex								
401217	1216	0x04C0	1	Input Parameter	Byte	1 - Voltage	0 - Input Disabled, 1 - Voltage, 2 - Current, 3 -Resistance, 4 - Discrete Voltage Level, 5 - Frequency, 6 - PWM Duty Cycle	N/A	R/W	Defines the input parameter that will be measured by the input.
401218	1217	0x04C1	1	Voltage Range	Byte	0 - 0...5V	0 - 0...5 V, 1 - 0...10 V	V	R/W	Used when Input Parameter is "Voltage"
401219	1218	0x04C2	1	Current Range	Byte	0 - 0...20 mA	0 - 0...20mA, 1 - 4...20 mA	mA	R/W	Used when Input Parameter is "Current"
401220	1219	0x04C3	1	Resistance Range	Byte	0 - Auto Range	0 - Auto Range, 1 -0...250Ohm, 2-0...2.5kOhm, 3- 0...25kOhm, 4-0...250kOhm	Ohm	R/W	Used when Input Parameter is "Resistance"
401221	1220	0x04C4	1	Voltage LoZ Input	Byte	0 - No	0 - No, 1 - Yes	N/A	R/W	Activates a 10kOhm pull-down resistor to avoid ghost voltages in the "Voltage" mode. Warning: Measurement accuracy will be decreased!
401222	1221	0x04C5	1	Analog Input Filter	Byte	0 - Disabled	0 - Disabled, 1 - 50Hz Noise Rejection, 2 - 60Hz Noise Rejection, 3 - Both: 60Hz and 50Hz Noise Rejection	N/A	R/W	Noise Rejection in "Voltage", "Current" and "Resistance" modes.
401223	1222	0x04C6	1	Pull-Up/Pull-Down Resistor	Byte	0 - Disabled	0 - Disabled, 1 - 10kOhm Pull-Up, 2 - 10 kOhm Pull-Down	N/A	R/W	Used in "Discrete Voltage Level", "Frequency", and "PWM Duty Cycle" modes.

Bit/Reg Address	Modbus Address		# of Reg	Name	Format	Default	Range	Units or Res.	Access	Description
	Dec	Hex								
401224	1223	0x04C7	1	Input Polarity	Byte	0 - Active High	0 - Active High, 1 - Active Low	N/A	R/W	Used in "Discrete Voltage Level", "Frequency", and "PWM Duty Cycle" modes.
401225	1224	0x04C8	1	Discrete Input Debounce Time	Word	50	0...1000ms	ms	R/W	Used in "Discrete Voltage Level". If 0 - no debouncing.
401226	1225	0x04C9	1	Frequency Range	Byte	0 - 100Hz...10kHz	0 - 100Hz...10kHz, 1 - 10Hz...1kHz, 2 - 1Hz...100Hz	Hz	RO	A 16-bit shared counter is used. The parameter is configured in Universal Input #2. Writing is allowed but does not change the value. Used in "Frequency", and "PWM Duty Cycle" modes.
401227	1226	0x04CA	1	Frequency/PWM Debounce Filter	Byte	0 - Disabled	0 - Disabled, 1 - 142ns, 2 - 1.14us, 3 - 6.10us	N/A	RO	The parameter is configured in Universal Input #2. Writing is allowed but does not change the value. Used in "Frequency", and "PWM Duty Cycle" modes.
401228	1227	0x04CB	1	Frequency/PWM Averaging	Byte	0 - No Averaging	0 - No Averaging, 1 - 3 Readings, 2 - 5 Readings, 3 - 10 Readings	N/A	R/W	Defines a moving average filter. Used in "Frequency", and "PWM Duty Cycle" modes.
401229	1228	0x04CC	20	Reserved	N/A	N/A	N/A	N/A	RO	Reserved for future use. Reading results in 0. Writing is allowed but does not change the value.

Universal Input #6

Bit/Reg Address	Modbus Address		# of Reg	Name	Format	Default	Range	Units or Res.	Access	Description
	Dec	Hex								
401249	1248	0x04E0	1	Input Parameter	Byte	1 - Voltage	0 - Input Disabled, 1 - Voltage, 2 - Current, 3 -Resistance, 4 - Discrete Voltage Level, 5 - Frequency, 6 - PWM Duty Cycle	N/A	R/W	Defines the input parameter that will be measured by the input.
401250	1249	0x04E1	1	Voltage Range	Byte	0 - 0...5V	0 - 0...5 V, 1 - 0...10 V	V	R/W	Used when Input Parameter is "Voltage"
401251	1250	0x04E2	1	Current Range	Byte	0 - 0...20 mA	0 - 0...20mA, 1 - 4...20 mA	mA	R/W	Used when Input Parameter is "Current"
401252	1251	0x04E3	1	Resistance Range	Byte	0 - Auto Range	0 - Auto Range, 1 -0...250Ohm, 2-0...2.5kOhm, 3 -0...25kOhm, 4-0...250kOhm	Ohm	R/W	Used when Input Parameter is "Resistance"
401253	1252	0x04E4	1	Voltage LoZ Input	Byte	0 - No	0 - No, 1 - Yes	N/A	R/W	Activates a 10kOhm pull-down resistor to avoid ghost voltages in the "Voltage" mode. Warning: Measurement accuracy will be decreased!
401254	1253	0x04E5	1	Analog Input Filter	Byte	0 - Disabled	0 - Disabled, 1 - 50Hz Noise Rejection, 2 - 60Hz Noise Rejection, 3 - Both: 60Hz and 50Hz Noise Rejection	N/A	R/W	Noise Rejection in "Voltage", "Current" and "Resistance" modes.
401255	1254	0x04E6	1	Pull-Up/Pull-Down Resistor	Byte	0 - Disabled	0 - Disabled, 1 - 10kOhm Pull-Up, 2 - 10 kOhm Pull-Down	N/A	R/W	Used in "Discrete Voltage Level", "Frequency", and "PWM Duty Cycle" modes.

Bit/Reg Address	Modbus Address		# of Reg	Name	Format	Default	Range	Units or Res.	Access	Description
	Dec	Hex								
401256	1255	0x04E7	1	Input Polarity	Byte	0 - Active High	0 - Active High, 1 - Active Low	N/A	R/W	Used in "Discrete Voltage Level", "Frequency", and "PWM Duty Cycle" modes.
401257	1256	0x04E8	1	Discrete Input Debounce Time	Word	50	0...1000ms	ms	R/W	Used in "Discrete Voltage Level". If 0 - no debouncing.
401258	1257	0x04E9	1	Frequency Range	Byte	0 - 100Hz...10kHz	0 - 100Hz...10kHz, 1 - 10Hz...1kHz, 2 - 1Hz...100Hz	Hz	R/W	A 16-bit counter is used. Used in "Frequency", and "PWM Duty Cycle" modes.
401259	1258	0x04EA	1	Frequency/PWM Debounce Filter	Byte	0 - Disabled	0 - Disabled, 1 - 142ns, 2 - 1.14us, 3 - 6.10us	N/A	R/W	Used in "Frequency", and "PWM Duty Cycle" modes.
401260	1259	0x04EB	1	Frequency/PWM Averaging	Byte	0 - No Averaging	0 - No Averaging, 1 - 3 Readings, 2 - 5 Readings, 3 - 10 Readings	N/A	R/W	Defines a moving average filter. Used in "Frequency", and "PWM Duty Cycle" modes.
401261	1260	0x04EC	20	Reserved	N/A	N/A	N/A	N/A	RO	Reserved for future use. Reading results in 0. Writing is allowed but does not change the value.
Universal Input #7										
401281	1280	0x0500	1	Input Parameter	Byte	1 - Voltage	0 - Input Disabled, 1 - Voltage, 2 - Current, 3 -Resistance, 4 - Discrete Voltage Level, 5 - Frequency, 6 - PWM Duty Cycle	N/A	R/W	Defines the input parameter that will be measured by the input.

Bit/Reg Address	Modbus Address		# of Reg	Name	Format	Default	Range	Units or Res.	Access	Description
	Dec	Hex								
401282	1281	0x0501	1	Voltage Range	Byte	0 - 0...5V	0 - 0...5 V, 1 - 0...10 V	V	R/W	Used when Input Parameter is "Voltage"
401283	1282	0x0502	1	Current Range	Byte	0 - 0...20 mA	0 - 0...20mA, 1 - 4...20 mA	mA	R/W	Used when Input Parameter is "Current"
401284	1283	0x0503	1	Resistance Range	Byte	0 - Auto Range	0 - Auto Range, 1- 0...250Ohm, 2-0...2.5kOhm, 3 -0...25kOhm, 4-0...250kOhm	Ohm	R/W	Used when Input Parameter is "Resistance"
401285	1284	0x0504	1	Voltage LoZ Input	Byte	0 - No	0 - No, 1 - Yes	N/A	R/W	Activates a 10kOhm pull-down resistor to avoid ghost voltages in the "Voltage" mode. Warning: Measurement accuracy will be decreased!
401286	1285	0x0505	1	Analog Input Filter	Byte	0 - Disabled	0 - Disabled, 1 - 50Hz Noise Rejection, 2 - 60Hz Noise Rejection, 3 - Both: 60Hz and 50Hz Noise Rejection	N/A	R/W	Noise Rejection in "Voltage", "Current" and "Resistance" modes.
401287	1286	0x0506	1	Pull-Up/Pull-Down Resistor	Byte	0 - Disabled	0 - Disabled, 1 - 10kOhm Pull-Up, 2 - 10 kOhm Pull-Down	N/A	R/W	Used in "Discrete Voltage Level", "Frequency", and "PWM Duty Cycle" modes.
401288	1287	0x0507	1	Input Polarity	Byte	0 - Active High	0 - Active High, 1 - Active Low	N/A	R/W	Used in "Discrete Voltage Level", "Frequency", and "PWM Duty Cycle" modes.
401289	1288	0x0508	1	Discrete Input Debounce Time	Word	50	0...1000ms	ms	R/W	Used in "Discrete Voltage Level". If 0 - no debouncing.
401290	1289	0x0509	1	Frequency Range	Byte	0 - 100Hz...10kHz	0 - 100Hz...10kHz,	Hz	R/W	A 16-bit counter is used.

Bit/Reg Address	Modbus Address		# of Reg	Name	Format	Default	Range	Units or Res.	Access	Description
	Dec	Hex								
							1 - 10Hz...1kHz, 2 - 1Hz...100Hz			Used in "Frequency", and "PWM Duty Cycle" modes.
401291	1290	0x050A	1	Frequency/PWM Debounce Filter	Byte	0 - Disabled	0 - Disabled, 1 - 142ns, 2 - 1.14us, 3 - 6.10us	N/A	R/W	Used in "Frequency", and "PWM Duty Cycle" modes.
401292	1291	0x050B	1	Frequency/PWM Averaging	Byte	0 - No Averaging	0 - No Averaging, 1 - 3 Readings, 2 - 5 Readings, 3 - 10 Readings	N/A	R/W	Defines a moving average filter. Used in "Frequency", and "PWM Duty Cycle" modes.
401293	1292	0x050C	20	Reserved	N/A	N/A	N/A	N/A	RO	Reserved for future use. Reading results in 0. Writing is allowed but does not change the value.
Universal Input #8										
401313	1312	0x0520	1	Input Parameter	Byte	1 - Voltage	0 - Input Disabled, 1 - Voltage, 2 - Current, 3 -Resistance, 4 - Discrete Voltage Level, 5 - Frequency, 6 - PWM Duty Cycle	N/A	R/W	Defines the input parameter that will be measured by the input.
401314	1313	0x0521	1	Voltage Range	Byte	0 - 0...5V	0 - 0...5 V, 1 - 0...10 V	V	R/W	Used when Input Parameter is "Voltage"
401315	1314	0x0522	1	Current Range	Byte	0 - 0...20 mA	0 - 0...20mA, 1 - 4...20 mA	mA	R/W	Used when Input Parameter is "Current"
401316	1315	0x0523	1	Resistance Range	Byte	0 - Auto Range	0 - Auto Range, 1 -0...250Ohm, 2-0...2.5kOhm, 3- 0...25kOhm, 4-0...250kOhm	Ohm	R/W	Used when Input Parameter is "Resistance"
401317	1316	0x0524	1	Voltage LoZ Input	Byte	0 - No	0 - No, 1 - Yes	N/A	R/W	Activates a 10kOhm pull-down resistor to

Bit/Reg Address	Modbus Address		# of Reg	Name	Format	Default	Range	Units or Res.	Access	Description
	Dec	Hex								
										avoid ghost voltages in the "Voltage" mode. Warning: Measurement accuracy will be decreased!
401318	1317	0x0525	1	Analog Input Filter	Byte	0 - Disabled	0 - Disabled, 1 - 50Hz Noise Rejection, 2 - 60Hz Noise Rejection, 3 - Both: 60Hz and 50Hz Noise Rejection	N/A	R/W	Noise Rejection in "Voltage", "Current" and "Resistance" modes.
401319	1318	0x0526	1	Pull-Up/Pull-Down Resistor	Byte	0 - Disabled	0 - Disabled, 1 - 10kOhm Pull-Up, 2 - 10 kOhm Pull-Down	N/A	R/W	Used in "Discrete Voltage Level", "Frequency", and "PWM Duty Cycle" modes.
401320	1319	0x0527	1	Input Polarity	Byte	0 - Active High	0 - Active High, 1 - Active Low	N/A	R/W	Used in "Discrete Voltage Level", "Frequency", and "PWM Duty Cycle" modes.
401321	1320	0x0528	1	Discrete Input Debounce Time	Word	50	0...1000ms	ms	R/W	Used in "Discrete Voltage Level". If 0 - no debouncing.
401322	1321	0x0529	1	Frequency Range	Byte	0 - 100Hz...10kHz	0 - 100Hz...10kHz, 1 - 10Hz...1kHz, 2 - 1Hz...100Hz	Hz	RO	A 16-bit shared counter is used. The parameter is configured in Universal Input #1. Writing is allowed but does not change the value. Used in "Frequency", and "PWM Duty Cycle" modes.
401323	1322	0x052A	1	Frequency/PWM Debounce Filter	Byte	0 - Disabled	0 - Disabled, 1 - 142ns,	N/A	RO	The parameter is configured in Universal Input #1.

Bit/Reg Address	Modbus Address		# of Reg	Name	Format	Default	Range	Units or Res.	Access	Description
	Dec	Hex								
							2 - 1.14us, 3 - 6.10us			Writing is allowed but does not change the value. Used in "Frequency", and "PWM Duty Cycle" modes.
401324	1323	0x052B	1	Frequency/PWM Averaging	Byte	0 - No Averaging	0 - No Averaging, 1 - 3 Readings, 2 - 5 Readings, 3 - 10 Readings	N/A	R/W	Defines a moving average filter. Used in "Frequency", and "PWM Duty Cycle" modes.
401325	1324	0x052C	20	Reserved	N/A	N/A	N/A	N/A	RO	Reserved for future use. Reading results in 0. Writing is allowed but does not change the value.
Binary Function #1										
401345	1344	0x0540	1	Binary Function	Byte	0 - Undefined	See Table 26. Binary Functions	N/A	R/W	F[x;y] – Binary function
401346	1345	0x0541	2	Output Scale	Float	1	Any value	N/A	R/W	A – Output Scale
401348	1347	0x0543	2	Output Offset	Float	0	Any value	N/A	R/W	B – Output Offset
401350	1349	0x0545	1	Input #1 Signal Source	Byte	0 - Not Connected	Any signal output of any function block or "Not connected". See Table 8. Controller Signal Sources	N/A	R/W	X1 – Input Signal #1
401351	1350	0x0546	1	Input #1 Signal Default	Byte	0 - No	0 - No, 1 - Yes	N/A	R/W	Defines whether the default signal value for X1 is defined.
401352	1351	0x0547	2	Input #1 Signal Default Value	Float	0	Any value	N/A	R/W	X1 default value, if Input #1 Signal Default is "Yes".
401354	1353	0x0549	1	Unary Function #1	Byte	0 - Undefined	See Table 25. Unary Functions	N/A	R/W	f1(x) – Unary function #1
401355	1354	0x054A	2	Scale #1	Float	1	Any value	N/A	R/W	a1 – Scale #1
401357	1356	0x054C	2	Offset #1	Float	0	Any value	N/A	R/W	b1 – Offset #1

Bit/Reg Address	Modbus Address		# of Reg	Name	Format	Default	Range	Units or Res.	Access	Description
	Dec	Hex								
401359	1358	0x054E	1	Input #2 Signal Source	Byte	0 - Not Connected	Any signal output of any function block or "Not connected". See Table 8. Controller Signal Sources	N/A	R/W	X2 – Input Signal #2
401360	1359	0x054F	1	Input #2 Signal Default	Byte	0 - No	0 - No, 1 - Yes	N/A	R/W	Defines whether the default signal value for X2 is defined.
401361	1360	0x0550	2	Input #2 Signal Default Value	Float	0	Any value	N/A	R/W	X2 default value, if Input #2 Signal Default is Yes.
401363	1362	0x0552	1	Unary Function #2	Byte	0 - Undefined	See Table 25. Unary Functions	N/A	R/W	f2(x) – Unary function #2
401364	1363	0x0553	2	Scale #2	Float	1	Any value	N/A	R/W	a2 – Scale #2
401366	1365	0x0555	2	Offset #2	Float	0	Any value	N/A	R/W	b2 – Offset #2
401368	1367	0x0557	9	Reserved	N/A	N/A	N/A	N/A	RO	Reserved for future use. Reading results in 0. Writing is allowed but does not change the value.
Binary Function #2										
401377	1376	0x0560	1	Binary Function	Byte	0 - Undefined	See Table 26. Binary Functions	N/A	R/W	F[x;y] – Binary function
401378	1377	0x0561	2	Output Scale	Float	1	Any value	N/A	R/W	A – Output Scale
401380	1379	0x0563	2	Output Offset	Float	0	Any value	N/A	R/W	B – Output Offset
401382	1381	0x0565	1	Input #1 Signal Source	Byte	0 - Not Connected	Any signal output of any function block or "Not connected". See Table 8. Controller Signal Sources	N/A	R/W	X1 – Input Signal #1
401383	1382	0x0566	1	Input #1 Signal Default	Byte	0 - No	0 - No, 1 - Yes	N/A	R/W	Defines whether the default signal value for X1 is defined.

Bit/Reg Address	Modbus Address		# of Reg	Name	Format	Default	Range	Units or Res.	Access	Description
	Dec	Hex								
401384	1383	0x0567	2	Input #1 Signal Default Value	Float	0	Any value	N/A	R/W	X1 default value, if Input #1 Signal Default is "Yes".
401386	1385	0x0569	1	Unary Function #1	Byte	0 - Undefined	See Table 25. Unary Functions	N/A	R/W	f1(x) – Unary function #1
401387	1386	0x056A	2	Scale #1	Float	1	Any value	N/A	R/W	a1 – Scale #1
401389	1388	0x056C	2	Offset #1	Float	0	Any value	N/A	R/W	b1 – Offset #1
401391	1390	0x056E	1	Input #2 Signal Source	Byte	0 - Not Connected	Any signal output of any function block or "Not connected". See Table 8. Controller Signal Sources	N/A	R/W	X2 – Input Signal #2
401392	1391	0x056F	1	Input #2 Signal Default	Byte	0 - No	0 - No, 1 - Yes	N/A	R/W	Defines whether the default signal value for X2 is defined.
401393	1392	0x0570	2	Input #2 Signal Default Value	Float	0	Any value	N/A	R/W	X2 default value, if Input #2 Signal Default is Yes.
401395	1394	0x0572	1	Unary Function #2	Byte	0 - Undefined	See Table 25. Unary Functions	N/A	R/W	f2(x) – Unary function #2
401396	1395	0x0573	2	Scale #2	Float	1	Any value	N/A	R/W	a2 – Scale #2
401398	1397	0x0575	2	Offset #2	Float	0	Any value	N/A	R/W	b2 – Offset #2
401400	1399	0x0577	9	Reserved	N/A	N/A	N/A	N/A	RO	Reserved for future use. Reading results in 0. Writing is allowed but does not change the value.
Binary Function #3										
401409	1408	0x0580	1	Binary Function	Byte	0 - Undefined	See Table 26. Binary Functions	N/A	R/W	F[x;y] – Binary function
401410	1409	0x0581	2	Output Scale	Float	1	Any value	N/A	R/W	A – Output Scale
401412	1411	0x0583	2	Output Offset	Float	0	Any value	N/A	R/W	B – Output Offset
401414	1413	0x0585	1	Input #1 Signal Source	Byte	0 - Not Connected	Any signal output of any function block or "Not connected". See Table 8.	N/A	R/W	X1 – Input Signal #1

Bit/Reg Address	Modbus Address		# of Reg	Name	Format	Default	Range	Units or Res.	Access	Description
	Dec	Hex								
							Controller Signal Sources			
401415	1414	0x0586	1	Input #1 Signal Default	Byte	0 - No	0 - No, 1 - Yes	N/A	R/W	Defines whether the default signal value for X1 is defined.
401416	1415	0x0587	2	Input #1 Signal Default Value	Float	0	Any value	N/A	R/W	X1 default value, if Input #1 Signal Default is "Yes".
401418	1417	0x0589	1	Unary Function #1	Byte	0 - Undefined	See Table 25. Unary Functions	N/A	R/W	f1(x) – Unary function #1
401419	1418	0x058A	2	Scale #1	Float	1	Any value	N/A	R/W	a1 – Scale #1
401421	1420	0x058C	2	Offset #1	Float	0	Any value	N/A	R/W	b1 – Offset #1
401423	1422	0x058E	1	Input #2 Signal Source	Byte	0 - Not Connected	Any signal output of any function block or "Not connected". See Table 8. Controller Signal Sources	N/A	R/W	X2 – Input Signal #2
401424	1423	0x058F	1	Input #2 Signal Default	Byte	0 - No	0 - No, 1 - Yes	N/A	R/W	Defines whether the default signal value for X2 is defined.
401425	1424	0x0590	2	Input #2 Signal Default Value	Float	0	Any value	N/A	R/W	X2 default value, if Input #2 Signal Default is Yes.
401427	1426	0x0592	1	Unary Function #2	Byte	0 - Undefined	See Table 25. Unary Functions	N/A	R/W	f2(x) – Unary function #2
401428	1427	0x0593	2	Scale #2	Float	1	Any value	N/A	R/W	a2 – Scale #2
401430	1429	0x0595	2	Offset #2	Float	0	Any value	N/A	R/W	b2 – Offset #2
401432	1431	0x0597	9	Reserved	N/A	N/A	N/A	N/A	RO	Reserved for future use. Reading results in 0. Writing is allowed but does not change the value.
Binary Function #4										
401441	1440	0x05A0	1	Binary Function	Byte	0 - Undefined	See Table 26. Binary Functions	N/A	R/W	F[x;y] – Binary function
401442	1441	0x05A1	2	Output Scale	Float	1	Any value	N/A	R/W	A – Output Scale
401444	1443	0x05A3	2	Output Offset	Float	0	Any value	N/A	R/W	B – Output Offset

Bit/Reg Address	Modbus Address		# of Reg	Name	Format	Default	Range	Units or Res.	Access	Description
	Dec	Hex								
401446	1445	0x05A5	1	Input #1 Signal Source	Byte	0 - Not Connected	Any signal output of any function block or "Not connected". See Table 8. Controller Signal Sources	N/A	R/W	X1 – Input Signal #1
401447	1446	0x05A6	1	Input #1 Signal Default	Byte	0 - No	0 - No, 1 - Yes	N/A	R/W	Defines whether the default signal value for X1 is defined.
401448	1447	0x05A7	2	Input #1 Signal Default Value	Float	0	Any value	N/A	R/W	X1 default value, if Input #1 Signal Default is "Yes".
401450	1449	0x05A9	1	Unary Function #1	Byte	0 - Undefined	See Table 25. Unary Functions	N/A	R/W	f1(x) – Unary function #1
401451	1450	0x05AA	2	Scale #1	Float	1	Any value	N/A	R/W	a1 – Scale #1
401453	1452	0x05AC	2	Offset #1	Float	0	Any value	N/A	R/W	b1 – Offset #1
401455	1454	0x05AE	1	Input #2 Signal Source	Byte	0 - Not Connected	Any signal output of any function block or "Not connected". See Table 8. Controller Signal Sources	N/A	R/W	X2 – Input Signal #2
401456	1455	0x05AF	1	Input #2 Signal Default	Byte	0 - No	0 - No, 1 - Yes	N/A	R/W	Defines whether the default signal value for X2 is defined.
401457	1456	0x05B0	2	Input #2 Signal Default Value	Float	0	Any value	N/A	R/W	X2 default value, if Input #2 Signal Default is Yes.
401459	1458	0x05B2	1	Unary Function #2	Byte	0 - Undefined	See Table 25. Unary Functions	N/A	R/W	f2(x) – Unary function #2
401460	1459	0x05B3	2	Scale #2	Float	1	Any value	N/A	R/W	a2 – Scale #2
401462	1461	0x05B5	2	Offset #2	Float	0	Any value	N/A	R/W	b2 – Offset #2
401464	1463	0x05B7	9	Reserved	N/A	N/A	N/A	N/A	RO	Reserved for future use. Reading results in 0. Writing is allowed but does not change the value.

Bit/Reg Address	Modbus Address		# of Reg	Name	Format	Default	Range	Units or Res.	Access	Description
	Dec	Hex								
Binary Function #5										
401473	1472	0x05C0	1	Binary Function	Byte	0 - Undefined	See Table 26. Binary Functions	N/A	R/W	F[x;y] – Binary function
401474	1473	0x05C1	2	Output Scale	Float	1	Any value	N/A	R/W	A – Output Scale
401476	1475	0x05C3	2	Output Offset	Float	0	Any value	N/A	R/W	B – Output Offset
401478	1477	0x05C5	1	Input #1 Signal Source	Byte	0 - Not Connected	Any signal output of any function block or "Not connected". See Table 8. Controller Signal Sources	N/A	R/W	X1 – Input Signal #1
401479	1478	0x05C6	1	Input #1 Signal Default	Byte	0 - No	0 - No, 1 - Yes	N/A	R/W	Defines whether the default signal value for X1 is defined.
401480	1479	0x05C7	2	Input #1 Signal Default Value	Float	0	Any value	N/A	R/W	X1 default value, if Input #1 Signal Default is "Yes".
401482	1481	0x05C9	1	Unary Function #1	Byte	0 - Undefined	See Table 25. Unary Functions	N/A	R/W	f1(x) – Unary function #1
401483	1482	0x05CA	2	Scale #1	Float	1	Any value	N/A	R/W	a1 – Scale #1
401485	1484	0x05CC	2	Offset #1	Float	0	Any value	N/A	R/W	b1 – Offset #1
401487	1486	0x05CE	1	Input #2 Signal Source	Byte	0 - Not Connected	Any signal output of any function block or "Not connected". See Table 8. Controller Signal Sources	N/A	R/W	X2 – Input Signal #2
401488	1487	0x05CF	1	Input #2 Signal Default	Byte	0 - No	0 - No, 1 - Yes	N/A	R/W	Defines whether the default signal value for X2 is defined.
401489	1488	0x05D0	2	Input #2 Signal Default Value	Float	0	Any value	N/A	R/W	X2 default value, if Input #2 Signal Default is Yes.
401491	1490	0x05D2	1	Unary Function #2	Byte	0 - Undefined	See Table 25. Unary Functions	N/A	R/W	f2(x) – Unary function #2
401492	1491	0x05D3	2	Scale #2	Float	1	Any value	N/A	R/W	a2 – Scale #2
401494	1493	0x05D5	2	Offset #2	Float	0	Any value	N/A	R/W	b2 – Offset #2

Bit/Reg Address	Modbus Address		# of Reg	Name	Format	Default	Range	Units or Res.	Access	Description
	Dec	Hex								
401496	1495	0x05D7	9	Reserved	N/A	N/A	N/A	N/A	RO	Reserved for future use. Reading results in 0. Writing is allowed but does not change the value.
Binary Function #6										
401505	1504	0x05E0	1	Binary Function	Byte	0 - Undefined	See Table 26. Binary Functions	N/A	R/W	F[x;y] – Binary function
401506	1505	0x05E1	2	Output Scale	Float	1	Any value	N/A	R/W	A – Output Scale
401508	1507	0x05E3	2	Output Offset	Float	0	Any value	N/A	R/W	B – Output Offset
401510	1509	0x05E5	1	Input #1 Signal Source	Byte	0 - Not Connected	Any signal output of any function block or "Not connected". See Table 8. Controller Signal Sources	N/A	R/W	X1 – Input Signal #1
401511	1510	0x05E6	1	Input #1 Signal Default	Byte	0 - No	0 - No, 1 - Yes	N/A	R/W	Defines whether the default signal value for X1 is defined.
401512	1511	0x05E7	2	Input #1 Signal Default Value	Float	0	Any value	N/A	R/W	X1 default value, if Input #1 Signal Default is "Yes".
401514	1513	0x05E9	1	Unary Function #1	Byte	0 - Undefined	See Table 25. Unary Functions	N/A	R/W	f1(x) – Unary function #1
401515	1514	0x05EA	2	Scale #1	Float	1	Any value	N/A	R/W	a1 – Scale #1
401517	1516	0x05EC	2	Offset #1	Float	0	Any value	N/A	R/W	b1 – Offset #1
401519	1518	0x05EE	1	Input #2 Signal Source	Byte	0 - Not Connected	Any signal output of any function block or "Not connected". See Table 8. Controller Signal Sources	N/A	R/W	X2 – Input Signal #2
401520	1519	0x05EF	1	Input #2 Signal Default	Byte	0 - No	0 - No, 1 - Yes	N/A	R/W	Defines whether the default signal value for X2 is defined.

Bit/Reg Address	Modbus Address		# of Reg	Name	Format	Default	Range	Units or Res.	Access	Description
	Dec	Hex								
401521	1520	0x05F0	2	Input #2 Signal Default Value	Float	0	Any value	N/A	R/W	X2 default value, if Input #2 Signal Default is Yes.
401523	1522	0x05F2	1	Unary Function #2	Byte	0 - Undefined	See Table 25. Unary Functions	N/A	R/W	f2(x) – Unary function #2
401524	1523	0x05F3	2	Scale #2	Float	1	Any value	N/A	R/W	a2 – Scale #2
401526	1525	0x05F5	2	Offset #2	Float	0	Any value	N/A	R/W	b2 – Offset #2
401528	1527	0x05F7	9	Reserved	N/A	N/A	N/A	N/A	RO	Reserved for future use. Reading results in 0. Writing is allowed but does not change the value.

Binary Function #7

401537	1536	0x0600	1	Binary Function	Byte	0 - Undefined	See Table 26. Binary Functions	N/A	R/W	F[x;y] – Binary function
401538	1537	0x0601	2	Output Scale	Float	1	Any value	N/A	R/W	A – Output Scale
401540	1539	0x0603	2	Output Offset	Float	0	Any value	N/A	R/W	B – Output Offset
401542	1541	0x0605	1	Input #1 Signal Source	Byte	0 - Not Connected	Any signal output of any function block or "Not connected". See Table 8. Controller Signal Sources	N/A	R/W	X1 – Input Signal #1
401543	1542	0x0606	1	Input #1 Signal Default	Byte	0 - No 1 - Yes	0 - No, 1 - Yes	N/A	R/W	Defines whether the default signal value for X1 is defined.
401544	1543	0x0607	2	Input #1 Signal Default Value	Float	0	Any value	N/A	R/W	X1 default value, if Input #1 Signal Default is "Yes".
401546	1545	0x0609	1	Unary Function #1	Byte	0 - Undefined	See Table 25. Unary Functions	N/A	R/W	f1(x) – Unary function #1
401547	1546	0x060A	2	Scale #1	Float	1	Any value	N/A	R/W	a1 – Scale #1
401549	1548	0x060C	2	Offset #1	Float	0	Any value	N/A	R/W	b1 – Offset #1
401551	1550	0x060E	1	Input #2 Signal Source	Byte	0 - Not Connected	Any signal output of any function block or "Not connected". See Table 8.	N/A	R/W	X2 – Input Signal #2

Bit/Reg Address	Modbus Address		# of Reg	Name	Format	Default	Range	Units or Res.	Access	Description
	Dec	Hex								
							Controller Signal Sources			
401552	1551	0x060F	1	Input #2 Signal Default	Byte	0 - No	0 - No, 1 - Yes	N/A	R/W	Defines whether the default signal value for X2 is defined.
401553	1552	0x0610	2	Input #2 Signal Default Value	Float	0	Any value	N/A	R/W	X2 default value, if Input #2 Signal Default is Yes.
401555	1554	0x0612	1	Unary Function #2	Byte	0 - Undefined	See Table 25. Unary Functions	N/A	R/W	f2(x) – Unary function #2
401556	1555	0x0613	2	Scale #2	Float	1	Any value	N/A	R/W	a2 – Scale #2
401558	1557	0x0615	2	Offset #2	Float	0	Any value	N/A	R/W	b2 – Offset #2
401560	1559	0x0617	9	Reserved	N/A	N/A	N/A	N/A	RO	Reserved for future use. Reading results in 0. Writing is allowed but does not change the value.
Binary Function #8										
401569	1568	0x0620	1	Binary Function	Byte	0 - Undefined	See Table 26. Binary Functions	N/A	R/W	F[x;y] – Binary function
401570	1569	0x0621	2	Output Scale	Float	1	Any value	N/A	R/W	A – Output Scale
401572	1571	0x0623	2	Output Offset	Float	0	Any value	N/A	R/W	B – Output Offset
401574	1573	0x0625	1	Input #1 Signal Source	Byte	0 - Not Connected	Any signal output of any function block or "Not connected". See Table 8. Controller Signal Sources	N/A	R/W	X1 – Input Signal #1
401575	1574	0x0626	1	Input #1 Signal Default	Byte	0 - No	0 - No, 1 - Yes	N/A	R/W	Defines whether the default signal value for X1 is defined.
401576	1575	0x0627	2	Input #1 Signal Default Value	Float	0	Any value	N/A	R/W	X1 default value, if Input #1 Signal Default is "Yes".
401578	1577	0x0629	1	Unary Function #1	Byte	0 - Undefined	See Table 25. Unary Functions	N/A	R/W	f1(x) – Unary function #1
401579	1578	0x062A	2	Scale #1	Float	1	Any value	N/A	R/W	a1 – Scale #1
401581	1580	0x062C	2	Offset #1	Float	0	Any value	N/A	R/W	b1 – Offset #1

Bit/Reg Address	Modbus Address		# of Reg	Name	Format	Default	Range	Units or Res.	Access	Description
	Dec	Hex								
401583	1582	0x062E	1	Input #2 Signal Source	Byte	0 - Not Connected	Any signal output of any function block or "Not connected". See Table 8. Controller Signal Sources	N/A	R/W	X2 – Input Signal #2
401584	1583	0x062F	1	Input #2 Signal Default	Byte	0 - No	0 - No, 1 - Yes	N/A	R/W	Defines whether the default signal value for X2 is defined.
401585	1584	0x0630	2	Input #2 Signal Default Value	Float	0	Any value	N/A	R/W	X2 default value, if Input #2 Signal Default is Yes.
401587	1586	0x0632	1	Unary Function #2	Byte	0 - Undefined	See Table 25. Unary Functions	N/A	R/W	f2(x) – Unary function #2
401588	1587	0x0633	2	Scale #2	Float	1	Any value	N/A	R/W	a2 – Scale #2
401590	1589	0x0635	2	Offset #2	Float	0	Any value	N/A	R/W	b2 – Offset #2
401592	1591	0x0637	9	Reserved	N/A	N/A	N/A	N/A	RO	Reserved for future use. Reading results in 0. Writing is allowed but does not change the value.
Binary Function #9										
401601	1600	0x0640	1	Binary Function	Byte	0 - Undefined	See Table 26. Binary Functions	N/A	R/W	F[x;y] – Binary function
401602	1601	0x0641	2	Output Scale	Float	1	Any value	N/A	R/W	A – Output Scale
401604	1603	0x0643	2	Output Offset	Float	0	Any value	N/A	R/W	B – Output Offset
401606	1605	0x0645	1	Input #1 Signal Source	Byte	0 - Not Connected	Any signal output of any function block or "Not connected". See Table 8. Controller Signal Sources	N/A	R/W	X1 – Input Signal #1
401607	1606	0x0646	1	Input #1 Signal Default	Byte	0 - No	0 - No, 1 - Yes	N/A	R/W	Defines whether the default signal value for X1 is defined.

Bit/Reg Address	Modbus Address		# of Reg	Name	Format	Default	Range	Units or Res.	Access	Description
	Dec	Hex								
401608	1607	0x0647	2	Input #1 Signal Default Value	Float	0	Any value	N/A	R/W	X1 default value, if Input #1 Signal Default is "Yes".
401610	1609	0x0649	1	Unary Function #1	Byte	0 - Undefined	See Table 25. Unary Functions	N/A	R/W	f1(x) – Unary function #1
401611	1610	0x064A	2	Scale #1	Float	1	Any value	N/A	R/W	a1 – Scale #1
401613	1612	0x064C	2	Offset #1	Float	0	Any value	N/A	R/W	b1 – Offset #1
401615	1614	0x064E	1	Input #2 Signal Source	Byte	0 - Not Connected	Any signal output of any function block or "Not connected". See Table 8. Controller Signal Sources	N/A	R/W	X2 – Input Signal #2
401616	1615	0x064F	1	Input #2 Signal Default	Byte	0 - No	0 - No, 1 - Yes	N/A	R/W	Defines whether the default signal value for X2 is defined.
401617	1616	0x0650	2	Input #2 Signal Default Value	Float	0	Any value	N/A	R/W	X2 default value, if Input #2 Signal Default is Yes.
401619	1618	0x0652	1	Unary Function #2	Byte	0 - Undefined	See Table 25. Unary Functions	N/A	R/W	f2(x) – Unary function #2
401620	1619	0x0653	2	Scale #2	Float	1	Any value	N/A	R/W	a2 – Scale #2
401622	1621	0x0655	2	Offset #2	Float	0	Any value	N/A	R/W	b2 – Offset #2
401624	1623	0x0657	9	Reserved	N/A	N/A	N/A	N/A	RO	Reserved for future use. Reading results in 0. Writing is allowed but does not change the value.
Binary Function #10										
401633	1632	0x0660	1	Binary Function	Byte	0 - Undefined	See Table 26. Binary Functions	N/A	R/W	F[x;y] – Binary function
401634	1633	0x0661	2	Output Scale	Float	1	Any value	N/A	R/W	A – Output Scale
401636	1635	0x0663	2	Output Offset	Float	0	Any value	N/A	R/W	B – Output Offset
401638	1637	0x0665	1	Input #1 Signal Source	Byte	0 - Not Connected	Any signal output of any function block or "Not connected". See Table 8.	N/A	R/W	X1 – Input Signal #1

Bit/Reg Address	Modbus Address		# of Reg	Name	Format	Default	Range	Units or Res.	Access	Description
	Dec	Hex								
							Controller Signal Sources			
401639	1638	0x0666	1	Input #1 Signal Default	Byte	0 - No	0 - No, 1 - Yes	N/A	R/W	Defines whether the default signal value for X1 is defined.
401640	1639	0x0667	2	Input #1 Signal Default Value	Float	0	Any value	N/A	R/W	X1 default value, if Input #1 Signal Default is "Yes".
401642	1641	0x0669	1	Unary Function #1	Byte	0 - Undefined	See Table 25. Unary Functions	N/A	R/W	f1(x) – Unary function #1
401643	1642	0x066A	2	Scale #1	Float	1	Any value	N/A	R/W	a1 – Scale #1
401645	1644	0x066C	2	Offset #1	Float	0	Any value	N/A	R/W	b1 – Offset #1
401647	1646	0x066E	1	Input #2 Signal Source	Byte	0 - Not Connected	Any signal output of any function block or "Not connected". See Table 8. Controller Signal Sources	N/A	R/W	X2 – Input Signal #2
401648	1647	0x066F	1	Input #2 Signal Default	Byte	0 - No	0 - No, 1 - Yes	N/A	R/W	Defines whether the default signal value for X2 is defined.
401649	1648	0x0670	2	Input #2 Signal Default Value	Float	0	Any value	N/A	R/W	X2 default value, if Input #2 Signal Default is Yes.
401651	1650	0x0672	1	Unary Function #2	Byte	0 - Undefined	See Table 25. Unary Functions	N/A	R/W	f2(x) – Unary function #2
401652	1651	0x0673	2	Scale #2	Float	1	Any value	N/A	R/W	a2 – Scale #2
401654	1653	0x0675	2	Offset #2	Float	0	Any value	N/A	R/W	b2 – Offset #2
401656	1655	0x0677	9	Reserved	N/A	N/A	N/A	N/A	RO	Reserved for future use. Reading results in 0. Writing is allowed but does not change the value.
Global Parameters										
401665	1664	0x0680	2	Global Continuous Constant Signal	Float	0	Any value	N/A	R/W	Output signal value of the Global Continuous Constant Signal

Bit/Reg Address	Modbus Address		# of Reg	Name	Format	Default	Range	Units or Res.	Access	Description
	Dec	Hex								
401667	1666	0x0682	2	Global Discrete Constant Signal	DWord	0	Any value [0...4294967295 (0xFFFFFFFF)]	N/A	R/W	Output signal value of the Global Discrete Constant Signal
401669	1668	0x0684	12	Reserved	N/A	N/A	N/A	N/A	RO	Reserved for future use. Reading results in 0. Writing is allowed but does not change the value.
J1939 Network										
401681	1680	0x0690	1	ECU Instance Number	Byte	0 - Instance #1	0...7 0 - Instance #1, ... 7 - Instance #8	N/A	R/W	ECU Instance field of the J1939 ECU Name
401682	1681	0x0691	1	ECU Address	Byte	128	0...253	N/A	R/W	J1939 ECU address
401683	1682	0x0692	1	Baud Rate	Word	250	{250, 500, 667, 1000}	kbit/s	RO	Current baud rate on the CAN network. Writing is allowed but does not change the value.
401684	1683	0x0693	1	Automatic Baud Rate Detection	Byte	1 - Yes	0 - No, 1 - Yes	N/A	R/W	Set to "No" once ECU is permanently installed on the CAN network.
401685	1684	0x0694	1	Slew Rate	Byte	0 - Low	0 - Low, 1 - High	N/A	R/W	Slew rate control of the CAN transceiver
401686	1685	0x0695	11	Reserved	N/A	N/A	N/A	N/A	RO	Reserved for future use. Reading results in 0. Writing is allowed but does not change the value.
Ethernet										
401697	1696	0x06A0	3	MAC Address	Byte[6]	Set at the factory	Any valid MAC address	N/A	RO	Ethernet MAC Address. Set at the factory. Writing is allowed but does not change the value.
401700	1699	0x06A3	2	IP Address	Byte[4]	192.168.0.34	Any IP address	N/A	R/W	The device IP address
401702	1701	0x06A5	2	Subnet Mask	Byte[4]	255.255.255.0	Any IP address	N/A	R/W	The device subnet mask

Bit/Reg Address	Modbus Address		# of Reg	Name	Format	Default	Range	Units or Res.	Access	Description
	Dec	Hex								
401704	1703	0x06A7	2	Gateway	Byte[4]	192.168.0.1	Any IP address	N/A	R/W	The device default gateway
401706	1705	0x06A9	1	Modbus Port	Word	502	Any port value except the Discovery Port (35100)	N/A	R/W	The Modbus listening port
401707	1706	0x06AA	1	Modbus Timeout	Word	1000	1...10000	ms	R/W	The Modbus communication timeout
401708	1707	0x06AB	21	Reserved	N/A	N/A	N/A	N/A	RO	Reserved for future use. Reading results in 0. Writing is allowed but does not change the value.
CAN Input Signal #1										
401729	1728	0x06C0	1	Signal Type	Byte	0 - Undefined	0 - Undefined, 1 - Discrete, 2 - Continuous	N/A	R/W	CAN input signal type
401730	1729	0x06C1	2	PGN	Dword	65535	Any J1939 PGN value	N/A	R/W	Signal message PGN value
401732	1731	0x06C3	1	PGN From Selected Address	Byte	0 - No	0 - No, 1 - Yes	N/A	R/W	Only CAN messages from the selected address will be accepted, if "Yes".
401733	1732	0x06C4	1	Selected Address	Byte	0	0...253	N/A	R/W	Address of the ECU transmitting CAN messages if PGN From Selected Address is set to "Yes".
401734	1733	0x06C5	1	Data Position Byte	Byte	1	1...8	N/A	R/W	Start byte of the CAN input signal in the CAN message data frame
401735	1734	0x06C6	1	Data Position Bit	Byte	1	1...8	N/A	R/W	Start bit of the CAN input signal in the Data Position Byte
401736	1735	0x06C7	1	Size	Byte	1	1...32	N/A	R/W	CAN input signal size
401737	1736	0x06C8	2	Resolution	Float	1	Any value	signal units / bit	R/W	CAN input signal resolution for continuous input signals.

Bit/Reg Address	Modbus Address		# of Reg	Name	Format	Default	Range	Units or Res.	Access	Description
	Dec	Hex								
401739	1738	0x06CA	2	Offset	Float	0	Any value	signal units	R/W	CAN input signal offset for continuous input signals.
401741	1740	0x06CC	1	Autoreset Time	Word	500	0...10000	ms	R/W	Function block signal output auto-reset time. If Autoreset Time is 0, the auto-reset is disabled.
401742	1741	0x06CD	19	Reserved	N/A	N/A	N/A	N/A	RO	Reserved for future use. Reading results in 0. Writing is allowed but does not change the value.
CAN Input Signal #2										
401761	1760	0x06E0	1	Signal Type	Byte	0 - Undefined	0 - Undefined, 1 - Discrete, 2 - Continuous	N/A	R/W	CAN input signal type
401762	1761	0x06E1	2	PGN	Dword	65535	Any J1939 PGN value	N/A	R/W	Signal message PGN value
401764	1763	0x06E3	1	PGN From Selected Address	Byte	0 - No	0 - No, 1 - Yes	N/A	R/W	Only CAN messages from the selected address will be accepted, if "Yes".
401765	1764	0x06E4	1	Selected Address	Byte	0	0...253	N/A	R/W	Address of the ECU transmitting CAN messages if PGN From Selected Address is set to "Yes".
401766	1765	0x06E5	1	Data Position Byte	Byte	1	1...8	N/A	R/W	Start byte of the CAN input signal in the CAN message data frame
401767	1766	0x06E6	1	Data Position Bit	Byte	1	1...8	N/A	R/W	Start bit of the CAN input signal in the Data Position Byte
401768	1767	0x06E7	1	Size	Byte	1	1...32	N/A	R/W	CAN input signal size
401769	1768	0x06E8	2	Resolution	Float	1	Any value	signal units / bit	R/W	CAN input signal resolution for continuous input signals.

Bit/Reg Address	Modbus Address		# of Reg	Name	Format	Default	Range	Units or Res.	Access	Description
	Dec	Hex								
401771	1770	0x06EA	2	Offset	Float	0	Any value	signal units	R/W	CAN input signal offset for continuous input signals.
401773	1772	0x06EC	1	Autoreset Time	Word	500	0...10000	ms	R/W	Function block signal output auto-reset time. If Autoreset Time is 0, the auto-reset is disabled.
401774	1773	0x06ED	19	Reserved	N/A	N/A	N/A	N/A	RO	Reserved for future use. Reading results in 0. Writing is allowed but does not change the value.
CAN Input Signal #3										
401793	1792	0x0700	1	Signal Type	Byte	0 - Undefined	0 - Undefined, 1 - Discrete, 2 - Continuous	N/A	R/W	CAN input signal type
401794	1793	0x0701	2	PGN	Dword	65535	Any J1939 PGN value	N/A	R/W	Signal message PGN value
401796	1795	0x0703	1	PGN From Selected Address	Byte	0 - No	0 - No, 1 - Yes	N/A	R/W	Only CAN messages from the selected address will be accepted, if "Yes".
401797	1796	0x0704	1	Selected Address	Byte	0	0...253	N/A	R/W	Address of the ECU transmitting CAN messages if PGN From Selected Address is set to "Yes".
401798	1797	0x0705	1	Data Position Byte	Byte	1	1...8	N/A	R/W	Start byte of the CAN input signal in the CAN message data frame
401799	1798	0x0706	1	Data Position Bit	Byte	1	1...8	N/A	R/W	Start bit of the CAN input signal in the Data Position Byte
401800	1799	0x0707	1	Size	Byte	1	1...32	bit	R/W	CAN input signal size
401801	1800	0x0708	2	Resolution	Float	1	Any value	signal units / bit	R/W	CAN input signal resolution for continuous input signals.

Bit/Reg Address	Modbus Address		# of Reg	Name	Format	Default	Range	Units or Res.	Access	Description
	Dec	Hex								
401803	1802	0x070A	2	Offset	Float	0	Any value	signal units	R/W	CAN input signal offset for continuous input signals.
401805	1804	0x070C	1	Autoreset Time	Word	500	0...10000	ms	R/W	Function block signal output auto-reset time. If Autoreset Time is 0, the auto-reset is disabled.
401806	1805	0x070D	19	Reserved	N/A	N/A	N/A	N/A	RO	Reserved for future use. Reading results in 0. Writing is allowed but does not change the value.
CAN Output Message #1										
401825	1824	0x0720	2	PGN	Dword	65535	Any J1939 PGN value	N/A	R/W	CAN message PGN
401827	1826	0x0722	1	Transmission Enable	Byte	0 - No	0 - No, 1 - Yes	N/A	R/W	Transmission Enable. Enables the CAN output message transmission
401828	1827	0x0723	1	Transmission Rate	Word	0	0...10000	ms	R/W	CAN output message transmission rate. If 0 – transmission is upon request.
401829	1828	0x0724	1	Destination Address	Byte	255	0...255	N/A	R/W	Destination address of the PDU1 PGN messages
401830	1829	0x0725	1	Length	Byte	8	0...8	byte	R/W	CAN message data frame length
401831	1830	0x0726	1	Priority	Byte	6	0...7	N/A	R/W	CAN message priority
401832	1831	0x0727	1	Signal #1 Type	Byte	0 - Undefined	0 - Undefined, 1 - Discrete, 2 - Continuous	N/A	R/W	CAN message data frame length. Type of the 1-st CAN output signal
401833	1832	0x0728	1	Signal #1 Source	Byte	0 - Not Connected	Any signal output of any function block or "Not connected". See Table 8.	N/A	R/W	Input signal source of the 1-st CAN output signal

Bit/Reg Address	Modbus Address		# of Reg	Name	Format	Default	Range	Units or Res.	Access	Description
	Dec	Hex								
							Controller Signal Sources			
401834	1833	0x0729	1	Signal #1 Byte Position	Byte	1	1...8	N/A	R/W	Byte position of the 1-st CAN output signal
401835	1834	0x072A	1	Signal #1 Bit Position	Byte	1	1...8	N/A	R/W	Bit position of the 1-st CAN output signal
401836	1835	0x072B	1	Signal #1 Size	Byte	1	1...32	bit	R/W	Size of the 1-st CAN output signal
401837	1836	0x072C	2	Signal #1 Resolution	Float	1	Any value	signal units / bit	R/W	Resolution of the 1-st CAN continuous output signal
401839	1838	0x072E	2	Signal #1 Offset	Float	0	Any value	signal units	R/W	Offset of the 1-st CAN continuous output signal
401841	1840	0x0730	1	Signal #2 Type	Byte	0 - Undefined	0 - Undefined, 1 - Discrete, 2 - Continuous	N/A	R/W	Type of the 2-nd CAN output signal
401842	1841	0x0731	1	Signal #2 Source	Byte	0 - Not Connected	Any signal output of any function block or "Not connected". See Table 8. Controller Signal Sources	N/A	R/W	Input signal source of the 2-nd CAN output signal
401843	1842	0x0732	1	Signal #2 Byte Position	Byte	1	1...8	N/A	R/W	Byte position of the 2-nd CAN output signal
401844	1843	0x0733	1	Signal #2 Bit Position	Byte	1	1...8	N/A	R/W	Bit position of the 2-nd CAN output signal
401845	1844	0x0734	1	Signal #2 Size	Byte	1	1...32	bit	R/W	Size of the 2-nd CAN output signal
401846	1845	0x0735	2	Signal #2 Resolution	Float	1	Any value	signal units / bit	R/W	Resolution of the 2-nd CAN continuous output signal
401848	1847	0x0737	2	Signal #2 Offset	Float	0	Any value	signal units	R/W	Offset of the 2-nd CAN continuous output signal
401850	1849	0x0739	1	Signal #3 Type	Byte	0 - Undefined	0 - Undefined, 1 - Discrete, 2 - Continuous	N/A	R/W	Type of the 3-rd CAN output signal

Bit/Reg Address	Modbus Address		# of Reg	Name	Format	Default	Range	Units or Res.	Access	Description
	Dec	Hex								
401851	1850	0x073A	1	Signal #3 Source	Byte	0 - Not Connected	Any signal output of any function block or "Not connected". See Table 8. Controller Signal Sources	N/A	R/W	Input signal source of the 3-rd CAN output signal
401852	1851	0x073B	1	Signal #3 Byte Position	Byte	1	1...8	N/A	R/W	Byte position of the 3-rd CAN output signal
401853	1852	0x073C	1	Signal #3 Bit Position	Byte	1	1...8	N/A	R/W	Bit position of the 3-rd CAN output signal
401854	1853	0x073D	1	Signal #3 Size	Byte	1	1...32	bit	R/W	Size of the 3-rd CAN output signal
401855	1854	0x073E	2	Signal #3 Resolution	Float	1	Any value	signal units / bit	R/W	Resolution of the 3-rd CAN continuous output signal
401857	1856	0x0740	2	Signal #3 Offset	Float	0	Any value	signal units	R/W	Offset of the 3-rd CAN continuous output signal
401859	1858	0x0742	1	Signal #4 Type	Byte	0 - Undefined	0 - Undefined, 1 - Discrete, 2 - Continuous	N/A	R/W	Type of the 4-th CAN output signal
401860	1859	0x0743	1	Signal #4 Source	Byte	0 - Not Connected	Any signal output of any function block or "Not connected". See Table 8. Controller Signal Sources	N/A	R/W	Input signal source of the 4-th CAN output signal
401861	1860	0x0744	1	Signal #4 Byte Position	Byte	1	1...8	N/A	R/W	Byte position of the 4-th CAN output signal
401862	1861	0x0745	1	Signal #4 Bit Position	Byte	1	1...8	N/A	R/W	Bit position of the 4-th CAN output signal
401863	1862	0x0746	1	Signal #4 Size	Byte	1	1...32	bit	R/W	Size of the 4-th CAN output signal
401864	1863	0x0747	2	Signal #4 Resolution	Float	1	Any value	signal units / bit	R/W	Resolution of the 4-th CAN continuous output signal

Bit/Reg Address	Modbus Address		# of Reg	Name	Format	Default	Range	Units or Res.	Access	Description
	Dec	Hex								
401866	1865	0x0749	2	Signal #4 Offset	Float	0	Any value	signal units	R/W	Offset of the 4-th CAN continuous output signal
401868	1867	0x074B	1	Signal #5 Type	Byte	0 - Undefined	0 - Undefined, 1 - Discrete, 2 - Continuous	N/A	R/W	Type of the 5-th CAN output signal
401869	1868	0x074C	1	Signal #5 Source	Byte	0 - Not Connected	Any signal output of any function block or "Not connected". See Table 8. Controller Signal Sources	N/A	R/W	Input signal source of the 5-th CAN output signal
401870	1869	0x074D	1	Signal #5 Byte Position	Byte	1	1...8	N/A	R/W	Byte position of the 5-th CAN output signal
401871	1870	0x074E	1	Signal #5 Bit Position	Byte	1	1...8	N/A	R/W	Bit position of the 5-th CAN output signal
401872	1871	0x074F	1	Signal #5 Size	Byte	1	1...32	bit	R/W	Size of the 5-th CAN output signal
401873	1872	0x0750	2	Signal #5 Resolution	Float	1	Any value	signal units / bit	R/W	Resolution of the 5-th CAN continuous output signal
401875	1874	0x0752	2	Signal #5 Offset	Float	0	Any value	signal units	R/W	Offset of the 5-th CAN continuous output signal
401877	1876	0x0754	1	Signal #6 Type	Byte	0 - Undefined	0 - Undefined, 1 - Discrete, 2 - Continuous	N/A	R/W	Type of the 6-th CAN output signal
401878	1877	0x0755	1	Signal #6 Source	Byte	0 - Not Connected	Any signal output of any function block or "Not connected". See Table 8. Controller Signal Sources	N/A	R/W	Input signal source of the 6-th CAN output signal
401879	1878	0x0756	1	Signal #6 Byte Position	Byte	1	1...8	N/A	R/W	Byte position of the 6-th CAN output signal
401880	1879	0x0757	1	Signal #6 Bit Position	Byte	1	1...8	N/A	R/W	Bit position of the 6-th CAN output signal

Bit/Reg Address	Modbus Address		# of Reg	Name	Format	Default	Range	Units or Res.	Access	Description
	Dec	Hex								
401881	1880	0x0758	1	Signal #6 Size	Byte	1	1...32	bit	R/W	Size of the 6-th CAN output signal
401882	1881	0x0759	2	Signal #6 Resolution	Float	1	Any value	signal units / bit	R/W	Resolution of the 6-th CAN continuous output signal
401884	1883	0x075B	2	Signal #6 Offset	Float	0	Any value	signal units	R/W	Offset of the 6-th CAN continuous output signal
401886	1885	0x075D	1	Signal #7 Type	Byte	0 - Undefined	0 - Undefined, 1 - Discrete, 2 - Continuous	N/A	R/W	Type of the 7-th CAN output signal
401887	1886	0x075E	1	Signal #7 Source	Byte	0 - Not Connected	Any signal output of any function block or "Not connected". See Table 8. Controller Signal Sources	N/A	R/W	Input signal source of the 7-th CAN output signal
401888	1887	0x075F	1	Signal #7 Byte Position	Byte	1	1...8	N/A	R/W	Byte position of the 7-th CAN output signal
401889	1888	0x0760	1	Signal #7 Bit Position	Byte	1	1...8	N/A	R/W	Bit position of the 7-th CAN output signal
401890	1889	0x0761	1	Signal #7 Size	Byte	1	1...32	bit	R/W	Size of the 7-th CAN output signal
401891	1890	0x0762	2	Signal #7 Resolution	Float	1	Any value	signal units / bit	R/W	Resolution of the 7-th CAN continuous output signal
401893	1892	0x0764	2	Signal #7 Offset	Float	0	Any value	signal units	R/W	Offset of the 7-th CAN continuous output signal
401895	1894	0x0766	1	Signal #8 Type	Byte	0 - Undefined	0 - Undefined, 1 - Discrete, 2 - Continuous	N/A	R/W	Type of the 8-th CAN output signal
401896	1895	0x0767	1	Signal #8 Source	Byte	0 - Not Connected	Any signal output of any function block or "Not connected". See Table 8.	N/A	R/W	Input signal source of the 8-th CAN output signal

Bit/Reg Address	Modbus Address		# of Reg	Name	Format	Default	Range	Units or Res.	Access	Description
	Dec	Hex								
							Controller Signal Sources			
401897	1896	0x0768	1	Signal #8 Byte Position	Byte	1	1...8	N/A	R/W	Byte position of the 8-th CAN output signal
401898	1897	0x0769	1	Signal #8 Bit Position	Byte	1	1...8	N/A	R/W	Bit position of the 8-th CAN output signal
401899	1898	0x076A	1	Signal #8 Size	Byte	1	1...32	bit	R/W	Size of the 8-th CAN output signal
401900	1899	0x076B	2	Signal #8 Resolution	Float	1	Any value	signal units / bit	R/W	Resolution of the 8-th CAN continuous output signal
401902	1901	0x076D	2	Signal #8 Offset	Float	0	Any value	signal units	R/W	Offset of the 8-th CAN continuous output signal
401904	1903	0x076F	1	Signal #9 Type	Byte	0 - Undefined	0 - Undefined, 1 - Discrete, 2 - Continuous	N/A	R/W	Type of the 9-th CAN output signal
401905	1904	0x0770	1	Signal #9 Source	Byte	0 - Not Connected	Any signal output of any function block or "Not connected". See Table 8. Controller Signal Sources	N/A	R/W	Input signal source of the 9-th CAN output signal
401906	1905	0x0771	1	Signal #9 Byte Position	Byte	1	1...8	N/A	R/W	Byte position of the 9-th CAN output signal
401907	1906	0x0772	1	Signal #9 Bit Position	Byte	1	1...8	N/A	R/W	Bit position of the 9-th CAN output signal
401908	1907	0x0773	1	Signal #9 Size	Byte	1	1...32	bit	R/W	Size of the 9-th CAN output signal
401909	1908	0x0774	2	Signal #9 Resolution	Float	1	Any value	signal units / bit	R/W	Resolution of the 9-th CAN continuous output signal
401911	1910	0x0776	2	Signal #9 Offset	Float	0	Any value	signal units	R/W	Offset of the 9-th CAN continuous output signal
401913	1912	0x0778	1	Signal #10 Type	Byte	0 - Undefined	0 - Undefined, 1 - Discrete, 2 - Continuous	N/A	R/W	Type of the 10-th CAN output signal

Bit/Reg Address	Modbus Address		# of Reg	Name	Format	Default	Range	Units or Res.	Access	Description
	Dec	Hex								
401914	1913	0x0779	1	Signal #10 Source	Byte	0 - Not Connected	Any signal output of any function block or "Not connected". See Table 8. Controller Signal Sources	N/A	R/W	Input signal source of the 10-th CAN output signal
401915	1914	0x077A	1	Signal #10 Byte Position	Byte	1	1...8	N/A	R/W	Byte position of the 10-th CAN output signal
401916	1915	0x077B	1	Signal #10 Bit Position	Byte	1	1...8	N/A	R/W	Bit position of the 10-th CAN output signal
401917	1916	0x077C	1	Signal #10 Size	Byte	1	1...32	bit	R/W	Size of the 10-th CAN output signal
401918	1917	0x077D	2	Signal #10 Resolution	Float	1	Any value	signal units / bit	R/W	Resolution of the 10-th CAN continuous output signal
401920	1919	0x077F	2	Signal #10 Offset	Float	0	Any value	signal units	R/W	Offset of the 10-th CAN continuous output signal
401922	1921	0x0781	15	Reserved	N/A	N/A	N/A	N/A	RO	Reserved for future use. Reading results in 0. Writing is allowed but does not change the value.
CAN Output Message #2										
401937	1936	0x0790	2	PGN	Dword	65535	Any J1939 PGN value	N/A	R/W	CAN message PGN
401939	1938	0x0792	1	Transmission Enable	Byte	0 - No	0 - No, 1 - Yes	N/A	R/W	Transmission Enable. Enables the CAN output message transmission
401940	1939	0x0793	1	Transmission Rate	Word	0	0...10000	ms	R/W	CAN output message transmission rate. If 0 – transmission is upon request.
401941	1940	0x0794	1	Destination Address	Byte	255	0...255	N/A	R/W	Destination address of the PDU1 PGN messages

Bit/Reg Address	Modbus Address		# of Reg	Name	Format	Default	Range	Units or Res.	Access	Description
	Dec	Hex								
401942	1941	0x0795	1	Length	Byte	8	0...8	byte	R/W	CAN message data frame length
401943	1942	0x0796	1	Priority	Byte	6	0...7	N/A	R/W	CAN message priority
401944	1943	0x0797	1	Signal #1 Type	Byte	0 - Undefined	0 - Undefined, 1 - Discrete, 2 - Continuous	N/A	R/W	CAN message data frame length. Type of the 1-st CAN output signal
401945	1944	0x0798	1	Signal #1 Source	Byte	0 - Not Connected	Any signal output of any function block or "Not connected". See Table 8. Controller Signal Sources	N/A	R/W	Input signal source of the 1-st CAN output signal
401946	1945	0x0799	1	Signal #1 Byte Position	Byte	1	1...8	N/A	R/W	Byte position of the 1-st CAN output signal
401947	1946	0x079A	1	Signal #1 Bit Position	Byte	1	1...8	N/A	R/W	Bit position of the 1-st CAN output signal
401948	1947	0x079B	1	Signal #1 Size	Byte	1	1...32	bit	R/W	Size of the 1-st CAN output signal
401949	1948	0x079C	2	Signal #1 Resolution	Float	1	Any value	signal units / bit	R/W	Resolution of the 1-st CAN continuous output signal
401951	1950	0x079E	2	Signal #1 Offset	Float	0	Any value	signal units	R/W	Offset of the 1-st CAN continuous output signal
401953	1952	0x07A0	1	Signal #2 Type	Byte	0 - Undefined	0 - Undefined, 1 - Discrete, 2 - Continuous	N/A	R/W	CAN message data frame length. Type of the 2-nd CAN output signal
401954	1953	0x07A1	1	Signal #2 Source	Byte	0 - Not Connected	Any signal output of any function block or "Not connected". See Table 8. Controller Signal Sources	N/A	R/W	Input signal source of the 2-nd CAN output signal
401955	1954	0x07A2	1	Signal #2 Byte Position	Byte	1	1...8	N/A	R/W	Byte position of the 2-nd CAN output signal

Bit/Reg Address	Modbus Address		# of Reg	Name	Format	Default	Range	Units or Res.	Access	Description
	Dec	Hex								
401956	1955	0x07A3	1	Signal #2 Bit Position	Byte	1	1...8	N/A	R/W	Bit position of the 2-nd CAN output signal
401957	1956	0x07A4	1	Signal #2 Size	Byte	1	1...32	bit	R/W	Size of the 2-nd CAN output signal
401958	1957	0x07A5	2	Signal #2 Resolution	Float	1	Any value	signal units / bit	R/W	Resolution of the 2-nd CAN continuous output signal
401960	1959	0x07A7	2	Signal #2 Offset	Float	0	Any value	signal units	R/W	Offset of the 2-nd CAN continuous output signal
401962	1961	0x07A9	1	Signal #3 Type	Byte	0 - Undefined	0 - Undefined, 1 - Discrete, 2 - Continuous	N/A	R/W	CAN message data frame length. Type of the 3-rd CAN output signal
401963	1962	0x07AA	1	Signal #3 Source	Byte	0 - Not Connected	Any signal output of any function block or "Not connected". See Table 8. Controller Signal Sources	N/A	R/W	Input signal source of the 3-rd CAN output signal
401964	1963	0x07AB	1	Signal #3 Byte Position	Byte	1	1...8	N/A	R/W	Byte position of the 3-rd CAN output signal
401965	1964	0x07AC	1	Signal #3 Bit Position	Byte	1	1...8	N/A	R/W	Bit position of the 3-rd CAN output signal
401966	1965	0x07AD	1	Signal #3 Size	Byte	1	1...32	bit	R/W	Size of the 3-rd CAN output signal
401967	1966	0x07AE	2	Signal #3 Resolution	Float	1	Any value	signal units / bit	R/W	Resolution of the 3-rd CAN continuous output signal
401969	1968	0x07B0	2	Signal #3 Offset	Float	0	Any value	signal units	R/W	Offset of the 3-rd CAN continuous output signal
401971	1970	0x07B2	1	Signal #4 Type	Byte	0 - Undefined	0 - Undefined, 1 - Discrete, 2 - Continuous	N/A	R/W	Type of the 4-th CAN output signal
401972	1971	0x07B3	1	Signal #4 Source	Byte	0 - Not Connected	Any signal output of any function block or "Not	N/A	R/W	Input signal source of the 4-th CAN output signal

Bit/Reg Address	Modbus Address		# of Reg	Name	Format	Default	Range	Units or Res.	Access	Description
	Dec	Hex								
							connected". See Table 8. Controller Signal Sources			
401973	1972	0x07B4	1	Signal #4 Byte Position	Byte	1	1...8	N/A	R/W	Byte position of the 4-th CAN output signal
401974	1973	0x07B5	1	Signal #4 Bit Position	Byte	1	1...8	N/A	R/W	Bit position of the 4-th CAN output signal
401975	1974	0x07B6	1	Signal #4 Size	Byte	1	1...32	bit	R/W	Size of the 4-th CAN output signal
401976	1975	0x07B7	2	Signal #4 Resolution	Float	1	Any value	signal units / bit	R/W	Resolution of the 4-th CAN continuous output signal
401978	1977	0x07B9	2	Signal #4 Offset	Float	0	Any value	signal units	R/W	Offset of the 4-th CAN continuous output signal
401980	1979	0x07BB	1	Signal #5 Type	Byte	0 - Undefined	0 - Undefined, 1 - Discrete, 2 - Continuous	N/A	R/W	Type of the 5-th CAN output signal
401981	1980	0x07BC	1	Signal #5 Source	Byte	0 - Not Connected	Any signal output of any function block or "Not connected". See Table 8. Controller Signal Sources	N/A	R/W	Input signal source of the 5-th CAN output signal
401982	1981	0x07BD	1	Signal #5 Byte Position	Byte	1	1...8	N/A	R/W	Byte position of the 5-th CAN output signal
401983	1982	0x07BE	1	Signal #5 Bit Position	Byte	1	1...8	N/A	R/W	Bit position of the 5-th CAN output signal
401984	1983	0x07BF	1	Signal #5 Size	Byte	1	1...32	bit	R/W	Size of the 5-th CAN output signal
401985	1984	0x07C0	2	Signal #5 Resolution	Float	1	Any value	signal units / bit	R/W	Resolution of the 5-th CAN continuous output signal
401987	1986	0x07C2	2	Signal #5 Offset	Float	0	Any value	signal units	R/W	Offset of the 5-th CAN continuous output signal

Bit/Reg Address	Modbus Address		# of Reg	Name	Format	Default	Range	Units or Res.	Access	Description
	Dec	Hex								
401989	1988	0x07C4	1	Signal #6 Type	Byte	0 - Undefined	0 - Undefined, 1 - Discrete, 2 - Continuous	N/A	R/W	Type of the 6-th CAN output signal
401990	1989	0x07C5	1	Signal #6 Source	Byte	0 - Not Connected	Any signal output of any function block or "Not connected". See Table 8. Controller Signal Sources	N/A	R/W	Input signal source of the 6-th CAN output signal
401991	1990	0x07C6	1	Signal #6 Byte Position	Byte	1	1...8	N/A	R/W	Byte position of the 6-th CAN output signal
401992	1991	0x07C7	1	Signal #6 Bit Position	Byte	1	1...8	N/A	R/W	Bit position of the 6-th CAN output signal
401993	1992	0x07C8	1	Signal #6 Size	Byte	1	1...32	bit	R/W	Size of the 6-th CAN output signal
401994	1993	0x07C9	2	Signal #6 Resolution	Float	1	Any value	signal units / bit	R/W	Resolution of the 6-th CAN continuous output signal
401996	1995	0x07CB	2	Signal #6 Offset	Float	0	Any value	signal units	R/W	Offset of the 6-th CAN continuous output signal
401998	1997	0x07CD	1	Signal #7 Type	Byte	0 - Undefined	0 - Undefined, 1 - Discrete, 2 - Continuous	N/A	R/W	Type of the 7-th CAN output signal
401999	1998	0x07CE	1	Signal #7 Source	Byte	0 - Not Connected	Any signal output of any function block or "Not connected". See Table 8. Controller Signal Sources	N/A	R/W	Input signal source of the 7-th CAN output signal
402000	1999	0x07CF	1	Signal #7 Byte Position	Byte	1	1...8	N/A	R/W	Byte position of the 7-th CAN output signal
402001	2000	0x07D0	1	Signal #7 Bit Position	Byte	1	1...8	N/A	R/W	Bit position of the 7-th CAN output signal
402002	2001	0x07D1	1	Signal #7 Size	Byte	1	1...32	bit	R/W	Size of the 7-th CAN output signal

Bit/Reg Address	Modbus Address		# of Reg	Name	Format	Default	Range	Units or Res.	Access	Description
	Dec	Hex								
402003	2002	0x07D2	2	Signal #7 Resolution	Float	1	Any value	signal units / bit	R/W	Resolution of the 7-th CAN continuous output signal
402005	2004	0x07D4	2	Signal #7 Offset	Float	0	Any value	signal units	R/W	Offset of the 7-th CAN continuous output signal
402007	2006	0x07D6	1	Signal #8 Type	Byte	0 - Undefined	0 - Undefined, 1 - Discrete, 2 - Continuous	N/A	R/W	Type of the 8-th CAN output signal
402008	2007	0x07D7	1	Signal #8 Source	Byte	0 - Not Connected	Any signal output of any function block or "Not connected". See Table 8. Controller Signal Sources	N/A	R/W	Input signal source of the 8-th CAN output signal
402009	2008	0x07D8	1	Signal #8 Byte Position	Byte	1	1...8	N/A	R/W	Byte position of the 8-th CAN output signal
402010	2009	0x07D9	1	Signal #8 Bit Position	Byte	1	1...8	N/A	R/W	Bit position of the 8-th CAN output signal
402011	2010	0x07DA	1	Signal #8 Size	Byte	1	1...32	bit	R/W	Size of the 8-th CAN output signal
402012	2011	0x07DB	2	Signal #8 Resolution	Float	1	Any value	signal units / bit	R/W	Resolution of the 8-th CAN continuous output signal
402014	2013	0x07DD	2	Signal #8 Offset	Float	0	Any value	signal units	R/W	Offset of the 8-th CAN continuous output signal
402016	2015	0x07DF	1	Signal #9 Type	Byte	0 - Undefined	0 - Undefined, 1 - Discrete, 2 - Continuous	N/A	R/W	Type of the 9-th CAN output signal
402017	2016	0x07E0	1	Signal #9 Source	Byte	0 - Not Connected	Any signal output of any function block or "Not connected". See Table 8. Controller Signal Sources	N/A	R/W	Input signal source of the 9-th CAN output signal

Bit/Reg Address	Modbus Address		# of Reg	Name	Format	Default	Range	Units or Res.	Access	Description
	Dec	Hex								
402018	2017	0x07E1	1	Signal #9 Byte Position	Byte	1	1...8	N/A	R/W	Byte position of the 9-th CAN output signal
402019	2018	0x07E2	1	Signal #9 Bit Position	Byte	1	1...8	N/A	R/W	Bit position of the 9-th CAN output signal
402020	2019	0x07E3	1	Signal #9 Size	Byte	1	1...32	bit	R/W	Size of the 9-th CAN output signal
402021	2020	0x07E4	2	Signal #9 Resolution	Float	1	Any value	signal units / bit	R/W	Resolution of the 9-th CAN continuous output signal
402023	2022	0x07E6	2	Signal #9 Offset	Float	0	Any value	signal units	R/W	Offset of the 9-th CAN continuous output signal
402025	2024	0x07E8	1	Signal #10 Type	Byte	0 - Undefined	0 - Undefined, 1 - Discrete, 2 - Continuous	N/A	R/W	Type of the 10-th CAN output signal
402026	2025	0x07E9	1	Signal #10 Source	Byte	0 - Not Connected	Any signal output of any function block or "Not connected". See Table 8. Controller Signal Sources	N/A	R/W	Input signal source of the 10-th CAN output signal
402027	2026	0x07EA	1	Signal #10 Byte Position	Byte	1	1...8	N/A	R/W	Byte position of the 10-th CAN output signal
402028	2027	0x07EB	1	Signal #10 Bit Position	Byte	1	1...8	N/A	R/W	Bit position of the 10-th CAN output signal
402029	2028	0x07EC	1	Signal #10 Size	Byte	1	1...32	bit	R/W	Size of the 10-th CAN output signal
402030	2029	0x07ED	2	Signal #10 Resolution	Float	1	Any value	signal units / bit	R/W	Resolution of the 10-th CAN continuous output signal
402032	2031	0x07EF	2	Signal #10 Offset	Float	0	Any value	signal units	R/W	Offset of the 10-th CAN continuous output signal
402034	2033	0x07F1	15	Reserved	N/A	N/A	N/A	N/A	RO	Reserved for future use. Reading results in 0. Writing is allowed but does not change the value.

Bit/Reg Address	Modbus Address		# of Reg	Name	Format	Default	Range	Units or Res.	Access	Description
	Dec	Hex								
CAN Output Message #3										
402049	2048	0x0800	2	PGN	Dword	65535	Any J1939 PGN value	N/A	R/W	CAN message PGN
402051	2050	0x0802	1	Transmission Enable	Byte	0 - No	0 - No, 1 - Yes	N/A	R/W	Transmission Enable. Enables the CAN output message transmission
402052	2051	0x0803	1	Transmission Rate	Word	0	0...10000	ms	R/W	CAN output message transmission rate. If 0 – transmission is upon request.
402053	2052	0x0804	1	Destination Address	Byte	255	0...255	N/A	R/W	Destination address of the PDU1 PGN messages
402054	2053	0x0805	1	Length	Byte	8	0...8	byte	R/W	CAN message data frame length
402055	2054	0x0806	1	Priority	Byte	6	0...7	N/A	R/W	CAN message priority
402056	2055	0x0807	1	Signal #1 Type	Byte	0 - Undefined	0 - Undefined, 1 - Discrete, 2 - Continuous	N/A	R/W	CAN message data frame length. Type of the 1-st CAN output signal
402057	2056	0x0808	1	Signal #1 Source	Byte	0 - Not Connected	Any signal output of any function block or "Not connected". See Table 8. Controller Signal Sources	N/A	R/W	Input signal source of the 1-st CAN output signal
402058	2057	0x0809	1	Signal #1 Byte Position	Byte	1	1...8	N/A	R/W	Byte position of the 1-st CAN output signal
402059	2058	0x080A	1	Signal #1 Bit Position	Byte	1	1...8	N/A	R/W	Bit position of the 1-st CAN output signal
402060	2059	0x080B	1	Signal #1 Size	Byte	1	1...32	bit	R/W	Size of the 1-st CAN output signal
402061	2060	0x080C	2	Signal #1 Resolution	Float	1	Any value	signal units / bit	R/W	Resolution of the 1-st CAN continuous output signal

Bit/Reg Address	Modbus Address		# of Reg	Name	Format	Default	Range	Units or Res.	Access	Description
	Dec	Hex								
402063	2062	0x080E	2	Signal #1 Offset	Float	0	Any value	signal units	R/W	Offset of the 1-st CAN continuous output signal
402065	2064	0x0810	1	Signal #2 Type	Byte	0 - Undefined	0 - Undefined, 1 - Discrete, 2 - Continuous	N/A	R/W	CAN message data frame length. Type of the 2-nd CAN output signal
402066	2065	0x0811	1	Signal #2 Source	Byte	0 - Not Connected	Any signal output of any function block or "Not connected". See Table 8. Controller Signal Sources	N/A	R/W	Input signal source of the 2-nd CAN output signal
402067	2066	0x0812	1	Signal #2 Byte Position	Byte	1	1...8	N/A	R/W	Byte position of the 2-nd CAN output signal
402068	2067	0x0813	1	Signal #2 Bit Position	Byte	1	1...8	N/A	R/W	Bit position of the 2-nd CAN output signal
402069	2068	0x0814	1	Signal #2 Size	Byte	1	1...32	bit	R/W	Size of the 2-nd CAN output signal
402070	2069	0x0815	2	Signal #2 Resolution	Float	1	Any value	signal units / bit	R/W	Resolution of the 2-nd CAN continuous output signal
402072	2071	0x0817	2	Signal #2 Offset	Float	0	Any value	signal units	R/W	Offset of the 2-nd CAN continuous output signal
402074	2073	0x0819	1	Signal #3 Type	Byte	0 - Undefined	0 - Undefined, 1 - Discrete, 2 - Continuous	N/A	R/W	CAN message data frame length. Type of the 3-rd CAN output signal
402075	2074	0x081A	1	Signal #3 Source	Byte	0 - Not Connected	Any signal output of any function block or "Not connected". See Table 8. Controller Signal Sources	N/A	R/W	Input signal source of the 3-rd CAN output signal
402076	2075	0x081B	1	Signal #3 Byte Position	Byte	1	1...8	N/A	R/W	Byte position of the 3-rd CAN output signal

Bit/Reg Address	Modbus Address		# of Reg	Name	Format	Default	Range	Units or Res.	Access	Description
	Dec	Hex								
402077	2076	0x081C	1	Signal #3 Bit Position	Byte	1	1...8	N/A	R/W	Bit position of the 3-rd CAN output signal
402078	2077	0x081D	1	Signal #3 Size	Byte	1	1...32	bit	R/W	Size of the 3-rd CAN output signal
402079	2078	0x081E	2	Signal #3 Resolution	Float	1	Any value	signal units / bit	R/W	Resolution of the 3-rd CAN continuous output signal
402081	2080	0x0820	2	Signal #3 Offset	Float	0	Any value	signal units	R/W	Offset of the 3-rd CAN continuous output signal
402083	2082	0x0822	1	Signal #4 Type	Byte	0 - Undefined	0 - Undefined, 1 - Discrete, 2 - Continuous	N/A	R/W	Type of the 4-th CAN output signal
402084	2083	0x0823	1	Signal #4 Source	Byte	0 - Not Connected	Any signal output of any function block or "Not connected". See Table 8. Controller Signal Sources	N/A	R/W	Input signal source of the 4-th CAN output signal
402085	2084	0x0824	1	Signal #4 Byte Position	Byte	1	1...8	N/A	R/W	Byte position of the 4-th CAN output signal
402086	2085	0x0825	1	Signal #4 Bit Position	Byte	1	1...8	N/A	R/W	Bit position of the 4-th CAN output signal
402087	2086	0x0826	1	Signal #4 Size	Byte	1	1...32	bit	R/W	Size of the 4-th CAN output signal
402088	2087	0x0827	2	Signal #4 Resolution	Float	1	Any value	signal units / bit	R/W	Resolution of the 4-th CAN continuous output signal
402090	2089	0x0829	2	Signal #4 Offset	Float	0	Any value	signal units	R/W	Offset of the 4-th CAN continuous output signal
402092	2091	0x082B	1	Signal #5 Type	Byte	0 - Undefined	0 - Undefined, 1 - Discrete, 2 - Continuous	N/A	R/W	Type of the 5-th CAN output signal
402093	2092	0x082C	1	Signal #5 Source	Byte	0 - Not Connected	Any signal output of any function block or "Not connected". See	N/A	R/W	Input signal source of the 5-th CAN output signal

Bit/Reg Address	Modbus Address		# of Reg	Name	Format	Default	Range	Units or Res.	Access	Description
	Dec	Hex								
							Table 8. Controller Signal Sources			
402094	2093	0x082D	1	Signal #5 Byte Position	Byte	1	1...8	N/A	R/W	Byte position of the 5-th CAN output signal
402095	2094	0x082E	1	Signal #5 Bit Position	Byte	1	1...8	N/A	R/W	Bit position of the 5-th CAN output signal
402096	2095	0x082F	1	Signal #5 Size	Byte	1	1...32	bit	R/W	Size of the 5-th CAN output signal
402097	2096	0x0830	2	Signal #5 Resolution	Float	1	Any value	signal units / bit	R/W	Resolution of the 5-th CAN continuous output signal
402099	2098	0x0832	2	Signal #5 Offset	Float	0	Any value	signal units	R/W	Offset of the 5-th CAN continuous output signal
402101	2100	0x0834	1	Signal #6 Type	Byte	0 - Undefined	0 - Undefined, 1 - Discrete, 2 - Continuous	N/A	R/W	Type of the 6-th CAN output signal
402102	2101	0x0835	1	Signal #6 Source	Byte	0 - Not Connected	Any signal output of any function block or "Not connected". See Table 8. Controller Signal Sources	N/A	R/W	Input signal source of the 6-th CAN output signal
402103	2102	0x0836	1	Signal #6 Byte Position	Byte	1	1...8	N/A	R/W	Byte position of the 6-th CAN output signal
402104	2103	0x0837	1	Signal #6 Bit Position	Byte	1	1...8	N/A	R/W	Bit position of the 6-th CAN output signal
402105	2104	0x0838	1	Signal #6 Size	Byte	1	1...32	bit	R/W	Size of the 6-th CAN output signal
402106	2105	0x0839	2	Signal #6 Resolution	Float	1	Any value	signal units / bit	R/W	Resolution of the 6-th CAN continuous output signal
402108	2107	0x083B	2	Signal #6 Offset	Float	0	Any value	signal units	R/W	Offset of the 6-th CAN continuous output signal

Bit/Reg Address	Modbus Address		# of Reg	Name	Format	Default	Range	Units or Res.	Access	Description
	Dec	Hex								
402110	2109	0x083D	1	Signal #7 Type	Byte	0 - Undefined	0 - Undefined, 1 - Discrete, 2 - Continuous	N/A	R/W	Type of the 7-th CAN output signal
402111	2110	0x083E	1	Signal #7 Source	Byte	0 - Not Connected	Any signal output of any function block or "Not connected". See Table 8. Controller Signal Sources	N/A	R/W	Input signal source of the 7-th CAN output signal
402112	2111	0x083F	1	Signal #7 Byte Position	Byte	1	1...8	N/A	R/W	Byte position of the 7-th CAN output signal
402113	2112	0x0840	1	Signal #7 Bit Position	Byte	1	1...8	N/A	R/W	Bit position of the 7-th CAN output signal
402114	2113	0x0841	1	Signal #7 Size	Byte	1	1...32	bit	R/W	Size of the 7-th CAN output signal
402115	2114	0x0842	2	Signal #7 Resolution	Float	1	Any value	signal units / bit	R/W	Resolution of the 7-th CAN continuous output signal
402117	2116	0x0844	2	Signal #7 Offset	Float	0	Any value	signal units	R/W	Offset of the 7-th CAN continuous output signal
402119	2118	0x0846	1	Signal #8 Type	Byte	0 - Undefined	0 - Undefined, 1 - Discrete, 2 - Continuous	N/A	R/W	Type of the 8-th CAN output signal
402120	2119	0x0847	1	Signal #8 Source	Byte	0 - Not Connected	Any signal output of any function block or "Not connected". See Table 8. Controller Signal Sources	N/A	R/W	Input signal source of the 8-th CAN output signal
402121	2120	0x0848	1	Signal #8 Byte Position	Byte	1	1...8	N/A	R/W	Byte position of the 8-th CAN output signal
402122	2121	0x0849	1	Signal #8 Bit Position	Byte	1	1...8	N/A	R/W	Bit position of the 8-th CAN output signal
402123	2122	0x084A	1	Signal #8 Size	Byte	1	1...32	bit	R/W	Size of the 8-th CAN output signal

Bit/Reg Address	Modbus Address		# of Reg	Name	Format	Default	Range	Units or Res.	Access	Description
	Dec	Hex								
402124	2123	0x084B	2	Signal #8 Resolution	Float	1	Any value	signal units / bit	R/W	Resolution of the 8-th CAN continuous output signal
402126	2125	0x084D	2	Signal #8 Offset	Float	0	Any value	signal units	R/W	Offset of the 8-th CAN continuous output signal
402128	2127	0x084F	1	Signal #9 Type	Byte	0 - Undefined	0 - Undefined, 1 - Discrete, 2 - Continuous	N/A	R/W	Type of the 9-th CAN output signal
402129	2128	0x0850	1	Signal #9 Source	Byte	0 - Not Connected	Any signal output of any function block or "Not connected". See Table 8. Controller Signal Sources	N/A	R/W	Input signal source of the 9-th CAN output signal
402130	2129	0x0851	1	Signal #9 Byte Position	Byte	1	1...8	N/A	R/W	Byte position of the 9-th CAN output signal
402131	2130	0x0852	1	Signal #9 Bit Position	Byte	1	1...8	N/A	R/W	Bit position of the 9-th CAN output signal
402132	2131	0x0853	1	Signal #9 Size	Byte	1	1...32	bit	R/W	Size of the 9-th CAN output signal
402133	2132	0x0854	2	Signal #9 Resolution	Float	1	Any value	signal units / bit	R/W	Resolution of the 9-th CAN continuous output signal
402135	2134	0x0856	2	Signal #9 Offset	Float	0	Any value	signal units	R/W	Offset of the 9-th CAN continuous output signal
402137	2136	0x0858	1	Signal #10 Type	Byte	0 - Undefined	0 - Undefined, 1 - Discrete, 2 - Continuous	N/A	R/W	Type of the 10-th CAN output signal
402138	2137	0x0859	1	Signal #10 Source	Byte	0 - Not Connected	Any signal output of any function block or "Not connected". See Table 8. Controller Signal Sources	N/A	R/W	Input signal source of the 10-th CAN output signal

Bit/Reg Address	Modbus Address		# of Reg	Name	Format	Default	Range	Units or Res.	Access	Description
	Dec	Hex								
402139	2138	0x085A	1	Signal #10 Byte Position	Byte	1	1...8	N/A	R/W	Byte position of the 10-th CAN output signal
402140	2139	0x085B	1	Signal #10 Bit Position	Byte	1	1...8	N/A	R/W	Bit position of the 10-th CAN output signal
402141	2140	0x085C	1	Signal #10 Size	Byte	1	1...32	bit	R/W	Size of the 10-th CAN output signal
402142	2141	0x085D	2	Signal #10 Resolution	Float	1	Any value	signal units / bit	R/W	Resolution of the 10-th CAN continuous output signal
402144	2143	0x085F	2	Signal #10 Offset	Float	0	Any value	signal units	R/W	Offset of the 10-th CAN continuous output signal
402146	2145	0x0861	15	Reserved	N/A	N/A	N/A	N/A	RO	Reserved for future use. Reading results in 0. Writing is allowed but does not change the value.
CAN Output Message #4										
402161	2160	0x0870	2	PGN	Dword	65535	Any J1939 PGN value	N/A	R/W	CAN message PGN
402163	2162	0x0872	1	Transmission Enable	Byte	0 - No	0 - No, 1 - Yes	N/A	R/W	Transmission Enable. Enables the CAN output message transmission
402164	2163	0x0873	1	Transmission Rate	Word	0	0...10000	ms	R/W	CAN output message transmission rate. If 0 – transmission is upon request.
402165	2164	0x0874	1	Destination Address	Byte	255	0...255	N/A	R/W	Destination address of the PDU1 PGN messages
402166	2165	0x0875	1	Length	Byte	8	0...8	byte	R/W	CAN message data frame length
402167	2166	0x0876	1	Priority	Byte	6	0...7	N/A	R/W	CAN message priority
402168	2167	0x0877	1	Signal #1 Type	Byte	0 - Undefined	0 - Undefined, 1 - Discrete, 2 - Continuous	N/A	R/W	CAN message data frame length. Type of the 1-st CAN output signal

Bit/Reg Address	Modbus Address		# of Reg	Name	Format	Default	Range	Units or Res.	Access	Description
	Dec	Hex								
402169	2168	0x0878	1	Signal #1 Source	Byte	0 - Not Connected	Any signal output of any function block or "Not connected". See Table 8. Controller Signal Sources	N/A	R/W	Input signal source of the 1-st CAN output signal
402170	2169	0x0879	1	Signal #1 Byte Position	Byte	1	1...8	N/A	R/W	Byte position of the 1-st CAN output signal
402171	2170	0x087A	1	Signal #1 Bit Position	Byte	1	1...8	N/A	R/W	Bit position of the 1-st CAN output signal
402172	2171	0x087B	1	Signal #1 Size	Byte	1	1...32	bit	R/W	Size of the 1-st CAN output signal
402173	2172	0x087C	2	Signal #1 Resolution	Float	1	Any value	signal units / bit	R/W	Resolution of the 1-st CAN continuous output signal
402175	2174	0x087E	2	Signal #1 Offset	Float	0	Any value	signal units	R/W	Offset of the 1-st CAN continuous output signal
402177	2176	0x0880	1	Signal #2 Type	Byte	0 - Undefined	0 - Undefined, 1 - Discrete, 2 - Continuous	N/A	R/W	CAN message data frame length. Type of the 2-nd CAN output signal
402178	2177	0x0881	1	Signal #2 Source	Byte	0 - Not Connected	Any signal output of any function block or "Not connected". See Table 8. Controller Signal Sources	N/A	R/W	Input signal source of the 2-nd CAN output signal
402179	2178	0x0882	1	Signal #2 Byte Position	Byte	1	1...8	N/A	R/W	Byte position of the 2-nd CAN output signal
402180	2179	0x0883	1	Signal #2 Bit Position	Byte	1	1...8	N/A	R/W	Bit position of the 2-nd CAN output signal
402181	2180	0x0884	1	Signal #2 Size	Byte	1	1...32	bit	R/W	Size of the 2-nd CAN output signal
402182	2181	0x0885	2	Signal #2 Resolution	Float	1	Any value	signal units / bit	R/W	Resolution of the 2-nd CAN continuous output signal

Bit/Reg Address	Modbus Address		# of Reg	Name	Format	Default	Range	Units or Res.	Access	Description
	Dec	Hex								
402184	2183	0x0887	2	Signal #2 Offset	Float	0	Any value	signal units	R/W	Offset of the 2-nd CAN continuous output signal
402186	2185	0x0889	1	Signal #3 Type	Byte	0 - Undefined	0 - Undefined, 1 - Discrete, 2 - Continuous	N/A	R/W	CAN message data frame length. Type of the 3-rd CAN output signal
402187	2186	0x088A	1	Signal #3 Source	Byte	0 - Not Connected	Any signal output of any function block or "Not connected". See Table 8. Controller Signal Sources	N/A	R/W	Input signal source of the 3-rd CAN output signal
402188	2187	0x088B	1	Signal #3 Byte Position	Byte	1	1...8	N/A	R/W	Byte position of the 3-rd CAN output signal
402189	2188	0x088C	1	Signal #3 Bit Position	Byte	1	1...8	N/A	R/W	Bit position of the 3-rd CAN output signal
402190	2189	0x088D	1	Signal #3 Size	Byte	1	1...32	bit	R/W	Size of the 3-rd CAN output signal
402191	2190	0x088E	2	Signal #3 Resolution	Float	1	Any value	signal units / bit	R/W	Resolution of the 3-rd CAN continuous output signal
402193	2192	0x0890	2	Signal #3 Offset	Float	0	Any value	signal units	R/W	Offset of the 3-rd CAN continuous output signal
402195	2194	0x0892	1	Signal #4 Type	Byte	0 - Undefined	0 - Undefined, 1 - Discrete, 2 - Continuous	N/A	R/W	Type of the 4-th CAN output signal
402196	2195	0x0893	1	Signal #4 Source	Byte	0 - Not Connected	Any signal output of any function block or "Not connected". See Table 8. Controller Signal Sources	N/A	R/W	Input signal source of the 4-th CAN output signal
402197	2196	0x0894	1	Signal #4 Byte Position	Byte	1	1...8	N/A	R/W	Byte position of the 4-th CAN output signal

Bit/Reg Address	Modbus Address		# of Reg	Name	Format	Default	Range	Units or Res.	Access	Description
	Dec	Hex								
402198	2197	0x0895	1	Signal #4 Bit Position	Byte	1	1...8	N/A	R/W	Bit position of the 4-th CAN output signal
402199	2198	0x0896	1	Signal #4 Size	Byte	1	1...32	bit	R/W	Size of the 4-th CAN output signal
402200	2199	0x0897	2	Signal #4 Resolution	Float	1	Any value	signal units / bit	R/W	Resolution of the 4-th CAN continuous output signal
402202	2201	0x0899	2	Signal #4 Offset	Float	0	Any value	signal units	R/W	Offset of the 4-th CAN continuous output signal
402204	2203	0x089B	1	Signal #5 Type	Byte	0 - Undefined	0 - Undefined, 1 - Discrete, 2 - Continuous	N/A	R/W	Type of the 5-th CAN output signal
402205	2204	0x089C	1	Signal #5 Source	Byte	0 - Not Connected	Any signal output of any function block or "Not connected". See Table 8. Controller Signal Sources	N/A	R/W	Input signal source of the 5-th CAN output signal
402206	2205	0x089D	1	Signal #5 Byte Position	Byte	1	1...8	N/A	R/W	Byte position of the 5-th CAN output signal
402207	2206	0x089E	1	Signal #5 Bit Position	Byte	1	1...8	N/A	R/W	Bit position of the 5-th CAN output signal
402208	2207	0x089F	1	Signal #5 Size	Byte	1	1...32	bit	R/W	Size of the 5-th CAN output signal
402209	2208	0x08A0	2	Signal #5 Resolution	Float	1	Any value	signal units / bit	R/W	Resolution of the 5-th CAN continuous output signal
402211	2210	0x08A2	2	Signal #5 Offset	Float	0	Any value	signal units	R/W	Offset of the 5-th CAN continuous output signal
402213	2212	0x08A4	1	Signal #6 Type	Byte	0 - Undefined	0 - Undefined, 1 - Discrete, 2 - Continuous	N/A	R/W	Type of the 6-th CAN output signal
402214	2213	0x08A5	1	Signal #6 Source	Byte	0 - Not Connected	Any signal output of any function block or "Not connected". See	N/A	R/W	Input signal source of the 6-th CAN output signal

Bit/Reg Address	Modbus Address		# of Reg	Name	Format	Default	Range	Units or Res.	Access	Description
	Dec	Hex								
							Table 8. Controller Signal Sources			
402215	2214	0x08A6	1	Signal #6 Byte Position	Byte	1	1...8	N/A	R/W	Byte position of the 6-th CAN output signal
402216	2215	0x08A7	1	Signal #6 Bit Position	Byte	1	1...8	N/A	R/W	Bit position of the 6-th CAN output signal
402217	2216	0x08A8	1	Signal #6 Size	Byte	1	1...32	bit	R/W	Size of the 6-th CAN output signal
402218	2217	0x08A9	2	Signal #6 Resolution	Float	1	Any value	signal units / bit	R/W	Resolution of the 6-th CAN continuous output signal
402220	2219	0x08AB	2	Signal #6 Offset	Float	0	Any value	signal units	R/W	Offset of the 6-th CAN continuous output signal
402222	2221	0x08AD	1	Signal #7 Type	Byte	0 - Undefined	0 - Undefined, 1 - Discrete, 2 - Continuous	N/A	R/W	Type of the 7-th CAN output signal
402223	2222	0x08AE	1	Signal #7 Source	Byte	0 - Not Connected	Any signal output of any function block or "Not connected". See Table 8. Controller Signal Sources	N/A	R/W	Input signal source of the 7-th CAN output signal
402224	2223	0x08AF	1	Signal #7 Byte Position	Byte	1	1...8	N/A	R/W	Byte position of the 7-th CAN output signal
402225	2224	0x08B0	1	Signal #7 Bit Position	Byte	1	1...8	N/A	R/W	Bit position of the 7-th CAN output signal
402226	2225	0x08B1	1	Signal #7 Size	Byte	1	1...32	bit	R/W	Size of the 7-th CAN output signal
402227	2226	0x08B2	2	Signal #7 Resolution	Float	1	Any value	signal units / bit	R/W	Resolution of the 7-th CAN continuous output signal
402229	2228	0x08B4	2	Signal #7 Offset	Float	0	Any value	signal units	R/W	Offset of the 7-th CAN continuous output signal

Bit/Reg Address	Modbus Address		# of Reg	Name	Format	Default	Range	Units or Res.	Access	Description
	Dec	Hex								
402231	2230	0x08B6	1	Signal #8 Type	Byte	0 - Undefined	0 - Undefined, 1 - Discrete, 2 - Continuous	N/A	R/W	Type of the 8-th CAN output signal
402232	2231	0x08B7	1	Signal #8 Source	Byte	0 - Not Connected	Any signal output of any function block or "Not connected". See Table 8. Controller Signal Sources	N/A	R/W	Input signal source of the 8-th CAN output signal
402233	2232	0x08B8	1	Signal #8 Byte Position	Byte	1	1...8	N/A	R/W	Byte position of the 8-th CAN output signal
402234	2233	0x08B9	1	Signal #8 Bit Position	Byte	1	1...8	N/A	R/W	Bit position of the 8-th CAN output signal
402235	2234	0x08BA	1	Signal #8 Size	Byte	1	1...32	bit	R/W	Size of the 8-th CAN output signal
402236	2235	0x08BB	2	Signal #8 Resolution	Float	1	Any value	signal units / bit	R/W	Resolution of the 8-th CAN continuous output signal
402238	2237	0x08BD	2	Signal #8 Offset	Float	0	Any value	signal units	R/W	Offset of the 8-th CAN continuous output signal
402240	2239	0x08BF	1	Signal #9 Type	Byte	0 - Undefined	0 - Undefined, 1 - Discrete, 2 - Continuous	N/A	R/W	Type of the 9-th CAN output signal
402241	2240	0x08C0	1	Signal #9 Source	Byte	0 - Not Connected	Any signal output of any function block or "Not connected". See Table 8. Controller Signal Sources	N/A	R/W	Input signal source of the 9-th CAN output signal
402242	2241	0x08C1	1	Signal #9 Byte Position	Byte	1	1...8	N/A	R/W	Byte position of the 9-th CAN output signal
402243	2242	0x08C2	1	Signal #9 Bit Position	Byte	1	1...8	N/A	R/W	Bit position of the 9-th CAN output signal
402244	2243	0x08C3	1	Signal #9 Size	Byte	1	1...32	bit	R/W	Size of the 9-th CAN output signal

Bit/Reg Address	Modbus Address		# of Reg	Name	Format	Default	Range	Units or Res.	Access	Description
	Dec	Hex								
402245	2244	0x08C4	2	Signal #9 Resolution	Float	1	Any value	signal units / bit	R/W	Resolution of the 9-th CAN continuous output signal
402247	2246	0x08C6	2	Signal #9 Offset	Float	0	Any value	signal units	R/W	Offset of the 9-th CAN continuous output signal
402249	2248	0x08C8	1	Signal #10 Type	Byte	0 - Undefined	0 - Undefined, 1 - Discrete, 2 - Continuous	N/A	R/W	Type of the 10-th CAN output signal
402250	2249	0x08C9	1	Signal #10 Source	Byte	0 - Not Connected	Any signal output of any function block or "Not connected". See Table 8. Controller Signal Sources	N/A	R/W	Input signal source of the 10-th CAN output signal
402251	2250	0x08CA	1	Signal #10 Byte Position	Byte	1	1...8	N/A	R/W	Byte position of the 10-th CAN output signal
402252	2251	0x08CB	1	Signal #10 Bit Position	Byte	1	1...8	N/A	R/W	Bit position of the 10-th CAN output signal
402253	2252	0x08CC	1	Signal #10 Size	Byte	1	1...32	bit	R/W	Size of the 10-th CAN output signal
402254	2253	0x08CD	2	Signal #10 Resolution	Float	1	Any value	signal units / bit	R/W	Resolution of the 10-th CAN continuous output signal
402256	2255	0x08CF	2	Signal #10 Offset	Float	0	Any value	signal units	R/W	Offset of the 10-th CAN continuous output signal
402258	2257	0x08D1	15	Reserved	N/A	N/A	N/A	N/A	RO	Reserved for future use. Reading results in 0. Writing is allowed but does not change the value.
CAN Output Message #5										
402273	2272	0x08E0	2	PGN	Dword	65535	Any J1939 PGN value	N/A	R/W	CAN message PGN
402275	2274	0x08E2	1	Transmission Enable	Byte	0 - No	0 - No, 1 - Yes	N/A	R/W	Transmission Enable. Enables the CAN

Bit/Reg Address	Modbus Address		# of Reg	Name	Format	Default	Range	Units or Res.	Access	Description
	Dec	Hex								
										output message transmission
402276	2275	0x08E3	1	Transmission Rate	Word	0	0...10000	ms	R/W	CAN output message transmission rate. If 0 – transmission is upon request.
402277	2276	0x08E4	1	Destination Address	Byte	255	0...255	N/A	R/W	Destination address of the PDU1 PGN messages
402278	2277	0x08E5	1	Length	Byte	8	0...8	byte	R/W	CAN message data frame length
402279	2278	0x08E6	1	Priority	Byte	6	0...7	N/A	R/W	CAN message priority
402280	2279	0x08E7	1	Signal #1 Type	Byte	0 - Undefined	0 - Undefined, 1 - Discrete, 2 - Continuous	N/A	R/W	CAN message data frame length. Type of the 1-st CAN output signal
402281	2280	0x08E8	1	Signal #1 Source	Byte	0 - Not Connected	Any signal output of any function block or "Not connected". See Table 8. Controller Signal Sources	N/A	R/W	Input signal source of the 1-st CAN output signal
402282	2281	0x08E9	1	Signal #1 Byte Position	Byte	1	1...8	N/A	R/W	Byte position of the 1-st CAN output signal
402283	2282	0x08EA	1	Signal #1 Bit Position	Byte	1	1...8	N/A	R/W	Bit position of the 1-st CAN output signal
402284	2283	0x08EB	1	Signal #1 Size	Byte	1	1...32	bit	R/W	Size of the 1-st CAN output signal
402285	2284	0x08EC	2	Signal #1 Resolution	Float	1	Any value	signal units / bit	R/W	Resolution of the 1-st CAN continuous output signal
402287	2286	0x08EE	2	Signal #1 Offset	Float	0	Any value	signal units	R/W	Offset of the 1-st CAN continuous output signal
402289	2288	0x08F0	1	Signal #2 Type	Byte	0 - Undefined	0 - Undefined, 1 - Discrete, 2 - Continuous	N/A	R/W	CAN message data frame length. Type of the 2-nd CAN output signal

Bit/Reg Address	Modbus Address		# of Reg	Name	Format	Default	Range	Units or Res.	Access	Description
	Dec	Hex								
402290	2289	0x08F1	1	Signal #2 Source	Byte	0 - Not Connected	Any signal output of any function block or "Not connected". See Table 8. Controller Signal Sources	N/A	R/W	Input signal source of the 2-nd CAN output signal
402291	2290	0x08F2	1	Signal #2 Byte Position	Byte	1	1...8	N/A	R/W	Byte position of the 2-nd CAN output signal
402292	2291	0x08F3	1	Signal #2 Bit Position	Byte	1	1...8	N/A	R/W	Bit position of the 2-nd CAN output signal
402293	2292	0x08F4	1	Signal #2 Size	Byte	1	1...32	bit	R/W	Size of the 2-nd CAN output signal
402294	2293	0x08F5	2	Signal #2 Resolution	Float	1	Any value	signal units / bit	R/W	Resolution of the 2-nd CAN continuous output signal
402296	2295	0x08F7	2	Signal #2 Offset	Float	0	Any value	signal units	R/W	Offset of the 2-nd CAN continuous output signal
402298	2297	0x08F9	1	Signal #3 Type	Byte	0 - Undefined	0 - Undefined, 1 - Discrete, 2 - Continuous	N/A	R/W	CAN message data frame length. Type of the 3-rd CAN output signal
402299	2298	0x08FA	1	Signal #3 Source	Byte	0 - Not Connected	Any signal output of any function block or "Not connected". See Table 8. Controller Signal Sources	N/A	R/W	Input signal source of the 3-rd CAN output signal
402300	2299	0x08FB	1	Signal #3 Byte Position	Byte	1	1...8	N/A	R/W	Byte position of the 3-rd CAN output signal
402301	2300	0x08FC	1	Signal #3 Bit Position	Byte	1	1...8	N/A	R/W	Bit position of the 3-rd CAN output signal
402302	2301	0x08FD	1	Signal #3 Size	Byte	1	1...32	bit	R/W	Size of the 3-rd CAN output signal
402303	2302	0x08FE	2	Signal #3 Resolution	Float	1	Any value	signal units / bit	R/W	Resolution of the 3-rd CAN continuous output signal

Bit/Reg Address	Modbus Address		# of Reg	Name	Format	Default	Range	Units or Res.	Access	Description
	Dec	Hex								
402305	2304	0x0900	2	Signal #3 Offset	Float	0	Any value	signal units	R/W	Offset of the 3-rd CAN continuous output signal
402307	2306	0x0902	1	Signal #4 Type	Byte	0 - Undefined	0 - Undefined, 1 - Discrete, 2 - Continuous	N/A	R/W	Type of the 4-th CAN output signal
402308	2307	0x0903	1	Signal #4 Source	Byte	0 - Not Connected	Any signal output of any function block or "Not connected". See Table 8. Controller Signal Sources	N/A	R/W	Input signal source of the 4-th CAN output signal
402309	2308	0x0904	1	Signal #4 Byte Position	Byte	1	1...8	N/A	R/W	Byte position of the 4-th CAN output signal
402310	2309	0x0905	1	Signal #4 Bit Position	Byte	1	1...8	N/A	R/W	Bit position of the 4-th CAN output signal
402311	2310	0x0906	1	Signal #4 Size	Byte	1	1...32	bit	R/W	Size of the 4-th CAN output signal
402312	2311	0x0907	2	Signal #4 Resolution	Float	1	Any value	signal units / bit	R/W	Resolution of the 4-th CAN continuous output signal
402314	2313	0x0909	2	Signal #4 Offset	Float	0	Any value	signal units	R/W	Offset of the 4-th CAN continuous output signal
402316	2315	0x090B	1	Signal #5 Type	Byte	0 - Undefined	0 - Undefined, 1 - Discrete, 2 - Continuous	N/A	R/W	Type of the 5-th CAN output signal
402317	2316	0x090C	1	Signal #5 Source	Byte	0 - Not Connected	Any signal output of any function block or "Not connected". See Table 8. Controller Signal Sources	N/A	R/W	Input signal source of the 5-th CAN output signal
402318	2317	0x090D	1	Signal #5 Byte Position	Byte	1	1...8	N/A	R/W	Byte position of the 5-th CAN output signal
402319	2318	0x090E	1	Signal #5 Bit Position	Byte	1	1...8	N/A	R/W	Bit position of the 5-th CAN output signal

Bit/Reg Address	Modbus Address		# of Reg	Name	Format	Default	Range	Units or Res.	Access	Description
	Dec	Hex								
402320	2319	0x090F	1	Signal #5 Size	Byte	1	1...32	bit	R/W	Size of the 5-th CAN output signal
402321	2320	0x0910	2	Signal #5 Resolution	Float	1	Any value	signal units / bit	R/W	Resolution of the 5-th CAN continuous output signal
402323	2322	0x0912	2	Signal #5 Offset	Float	0	Any value	signal units	R/W	Offset of the 5-th CAN continuous output signal
402325	2324	0x0914	1	Signal #6 Type	Byte	0 - Undefined	0 - Undefined, 1 - Discrete, 2 - Continuous	N/A	R/W	Type of the 6-th CAN output signal
402326	2325	0x0915	1	Signal #6 Source	Byte	0 - Not Connected	Any signal output of any function block or "Not connected". See Table 8. Controller Signal Sources	N/A	R/W	Input signal source of the 6-th CAN output signal
402327	2326	0x0916	1	Signal #6 Byte Position	Byte	1	1...8	N/A	R/W	Byte position of the 6-th CAN output signal
402328	2327	0x0917	1	Signal #6 Bit Position	Byte	1	1...8	N/A	R/W	Bit position of the 6-th CAN output signal
402329	2328	0x0918	1	Signal #6 Size	Byte	1	1...32	bit	R/W	Size of the 6-th CAN output signal
402330	2329	0x0919	2	Signal #6 Resolution	Float	1	Any value	signal units / bit	R/W	Resolution of the 6-th CAN continuous output signal
402332	2331	0x091B	2	Signal #6 Offset	Float	0	Any value	signal units	R/W	Offset of the 6-th CAN continuous output signal
402334	2333	0x091D	1	Signal #7 Type	Byte	0 - Undefined	0 - Undefined, 1 - Discrete, 2 - Continuous	N/A	R/W	Type of the 7-th CAN output signal
402335	2334	0x091E	1	Signal #7 Source	Byte	0 - Not Connected	Any signal output of any function block or "Not connected". See Table 8.	N/A	R/W	Input signal source of the 7-th CAN output signal

Bit/Reg Address	Modbus Address		# of Reg	Name	Format	Default	Range	Units or Res.	Access	Description
	Dec	Hex								
							Controller Signal Sources			
402336	2335	0x091F	1	Signal #7 Byte Position	Byte	1	1...8	N/A	R/W	Byte position of the 7-th CAN output signal
402337	2336	0x0920	1	Signal #7 Bit Position	Byte	1	1...8	N/A	R/W	Bit position of the 7-th CAN output signal
402338	2337	0x0921	1	Signal #7 Size	Byte	1	1...32	bit	R/W	Size of the 7-th CAN output signal
402339	2338	0x0922	2	Signal #7 Resolution	Float	1	Any value	signal units / bit	R/W	Resolution of the 7-th CAN continuous output signal
402341	2340	0x0924	2	Signal #7 Offset	Float	0	Any value	signal units	R/W	Offset of the 7-th CAN continuous output signal
402343	2342	0x0926	1	Signal #8 Type	Byte	0 - Undefined	0 - Undefined, 1 - Discrete, 2 - Continuous	N/A	R/W	Type of the 8-th CAN output signal
402344	2343	0x0927	1	Signal #8 Source	Byte	0 - Not Connected	Any signal output of any function block or "Not connected". See Table 8. Controller Signal Sources	N/A	R/W	Input signal source of the 8-th CAN output signal
402345	2344	0x0928	1	Signal #8 Byte Position	Byte	1	1...8	N/A	R/W	Byte position of the 8-th CAN output signal
402346	2345	0x0929	1	Signal #8 Bit Position	Byte	1	1...8	N/A	R/W	Bit position of the 8-th CAN output signal
402347	2346	0x092A	1	Signal #8 Size	Byte	1	1...32	bit	R/W	Size of the 8-th CAN output signal
402348	2347	0x092B	2	Signal #8 Resolution	Float	1	Any value	signal units / bit	R/W	Resolution of the 8-th CAN continuous output signal
402350	2349	0x092D	2	Signal #8 Offset	Float	0	Any value	signal units	R/W	Offset of the 8-th CAN continuous output signal
402352	2351	0x092F	1	Signal #9 Type	Byte	0 - Undefined	0 - Undefined, 1 - Discrete, 2 - Continuous	N/A	R/W	Type of the 9-th CAN output signal

Bit/Reg Address	Modbus Address		# of Reg	Name	Format	Default	Range	Units or Res.	Access	Description
	Dec	Hex								
402353	2352	0x0930	1	Signal #9 Source	Byte	0 - Not Connected	Any signal output of any function block or "Not connected". See Table 8. Controller Signal Sources	N/A	R/W	Input signal source of the 9-th CAN output signal
402354	2353	0x0931	1	Signal #9 Byte Position	Byte	1	1...8	N/A	R/W	Byte position of the 9-th CAN output signal
402355	2354	0x0932	1	Signal #9 Bit Position	Byte	1	1...8	N/A	R/W	Bit position of the 9-th CAN output signal
402356	2355	0x0933	1	Signal #9 Size	Byte	1	1...32	bit	R/W	Size of the 9-th CAN output signal
402357	2356	0x0934	2	Signal #9 Resolution	Float	1	Any value	signal units / bit	R/W	Resolution of the 9-th CAN continuous output signal
402359	2358	0x0936	2	Signal #9 Offset	Float	0	Any value	signal units	R/W	Offset of the 9-th CAN continuous output signal
402361	2360	0x0938	1	Signal #10 Type	Byte	0 - Undefined	0 - Undefined, 1 - Discrete, 2 - Continuous	N/A	R/W	Type of the 10-th CAN output signal
402362	2361	0x0939	1	Signal #10 Source	Byte	0 - Not Connected	Any signal output of any function block or "Not connected". See Table 8. Controller Signal Sources	N/A	R/W	Input signal source of the 10-th CAN output signal
402363	2362	0x093A	1	Signal #10 Byte Position	Byte	1	1...8	N/A	R/W	Byte position of the 10-th CAN output signal
402364	2363	0x093B	1	Signal #10 Bit Position	Byte	1	1...8	N/A	R/W	Bit position of the 10-th CAN output signal
402365	2364	0x093C	1	Signal #10 Size	Byte	1	1...32	bit	R/W	Size of the 10-th CAN output signal
402366	2365	0x093D	2	Signal #10 Resolution	Float	1	Any value	signal units / bit	R/W	Resolution of the 10-th CAN continuous output signal

Bit/Reg Address	Modbus Address		# of Reg	Name	Format	Default	Range	Units or Res.	Access	Description
	Dec	Hex								
402368	2367	0x093F	2	Signal #10 Offset	Float	0	Any value	signal units	R/W	Offset of the 10-th CAN continuous output signal
402370	2369	0x0941	15	Reserved	N/A	N/A	N/A	N/A	RO	Reserved for future use. Reading results in 0. Writing is allowed but does not change the value.

8 THIRD-PARTY SOFTWARE LICENSE NOTICES

This section contains Third-Party Software License Notices and/or Additional Terms and Conditions for licensed third-party software components included in the 2 Bipolar, 8 Universal Signal Input Controller with SAE J1939 and Ethernet firmware.

Table 42. Third-Party Software License Notices

Third-Party Software	License Notice/Terms
STMicroelectronics microcontroller support software	<p>COPYRIGHT(c) 2017 STMicroelectronics</p> <p>Redistribution and use in source and binary forms, with or without modification, are permitted provided that the following conditions are met: Redistributions of source code must retain the above copyright notice, this list of conditions and the following disclaimer. Redistributions in binary form must reproduce the above copyright notice, this list of conditions and the following disclaimer in the documentation and/or other materials provided with the distribution. Neither the name of STMicroelectronics nor the names of its contributors may be used to endorse or promote products derived from this software without specific prior written permission.</p> <p>THIS SOFTWARE IS PROVIDED BY THE COPYRIGHT HOLDERS AND CONTRIBUTORS "AS IS" AND ANY EXPRESS OR IMPLIED WARRANTIES, INCLUDING, BUT NOT LIMITED TO, THE IMPLIED WARRANTIES OF MERCHANTABILITY AND FITNESS FOR A PARTICULAR PURPOSE ARE DISCLAIMED. IN NO EVENT SHALL THE COPYRIGHT HOLDER OR CONTRIBUTORS BE LIABLE FOR ANY DIRECT, INDIRECT, INCIDENTAL, SPECIAL, EXEMPLARY, OR CONSEQUENTIAL DAMAGES (INCLUDING, BUT NOT LIMITED TO, PROCUREMENT OF SUBSTITUTE GOODS OR SERVICES; LOSS OF USE, DATA, OR PROFITS; OR BUSINESS INTERRUPTION) HOWEVER CAUSED AND ON ANY THEORY OF LIABILITY, WHETHER IN CONTRACT, STRICT LIABILITY, OR TORT (INCLUDING NEGLIGENCE OR OTHERWISE) ARISING IN ANY WAY OUT OF THE USE OF THIS SOFTWARE, EVEN IF ADVISED OF THE POSSIBILITY OF SUCH DAMAGE.</p> <p>Licensed under MCD-ST Liberty SW License Agreement V2, (the "License"); You may not use this file except in compliance with the License. You may obtain a copy of the License at: http://www.st.com/software_license_agreement_liberty_v2</p> <p>Unless required by applicable law or agreed to in writing, software distributed under the License is distributed on an "AS IS" BASIS, WITHOUT WARRANTIES OR CONDITIONS OF ANY KIND, either express or implied. See the License for the specific language governing permissions and limitations under the License.</p>
FreeRTOS Kernel V10.2.0	<p>Copyright (C) 2019 Amazon.com, Inc. or its affiliates. All Rights Reserved.</p> <p>Permission is hereby granted, free of charge, to any person obtaining a copy of this software and associated documentation files (the "Software"), to deal in the Software without restriction, including without limitation the rights to use, copy, modify, merge, publish, distribute, sublicense, and/or sell copies of the Software, and to permit persons to whom the Software is furnished to do so, subject to the following conditions:</p> <p>The above copyright notice and this permission notice shall be included in all copies or substantial portions of the Software.</p>

Third-Party Software	License Notice/Terms
	<p>THE SOFTWARE IS PROVIDED "AS IS", WITHOUT WARRANTY OF ANY KIND, EXPRESS OR IMPLIED, INCLUDING BUT NOT LIMITED TO THE WARRANTIES OF MERCHANTABILITY, FITNESS FOR A PARTICULAR PURPOSE AND NONINFRINGEMENT. IN NO EVENT SHALL THE AUTHORS OR COPYRIGHT HOLDERS BE LIABLE FOR ANY CLAIM, DAMAGES OR OTHER LIABILITY, WHETHER IN AN ACTION OF CONTRACT, TORT OR OTHERWISE, ARISING FROM, OUT OF OR IN CONNECTION WITH THE SOFTWARE OR THE USE OR OTHER DEALINGS IN THE SOFTWARE.</p>
FreeRTOS+TCP V2.2.0	<p>Copyright (C) 2017 Amazon.com, Inc. or its affiliates. All Rights Reserved.</p> <p>Permission is hereby granted, free of charge, to any person obtaining a copy of this software and associated documentation files (the "Software"), to deal in the Software without restriction, including without limitation the rights to use, copy, modify, merge, publish, distribute, sublicense, and/or sell copies of the Software, and to permit persons to whom the Software is furnished to do so, subject to the following conditions:</p> <p>The above copyright notice and this permission notice shall be included in all copies or substantial portions of the Software.</p> <p>THE SOFTWARE IS PROVIDED "AS IS", WITHOUT WARRANTY OF ANY KIND, EXPRESS OR IMPLIED, INCLUDING BUT NOT LIMITED TO THE WARRANTIES OF MERCHANTABILITY, FITNESS FOR A PARTICULAR PURPOSE AND NONINFRINGEMENT. IN NO EVENT SHALL THE AUTHORS OR COPYRIGHT HOLDERS BE LIABLE FOR ANY CLAIM, DAMAGES OR OTHER LIABILITY, WHETHER IN AN ACTION OF CONTRACT, TORT OR OTHERWISE, ARISING FROM, OUT OF OR IN CONNECTION WITH THE SOFTWARE OR THE USE OR OTHER DEALINGS IN THE SOFTWARE.</p>

9 VERSION HISTORY

User Manual Version	Firmware version	Electronic Assistant® (EA) version	Date	Author	Modifications
1D	1.xx	5.15.113.0 or higher	Nov. 12, 2021	Olek Bogush	<ul style="list-style-type: none"> Corrected pinout (swapped J4 and J6) on <i>Dimensional Drawing</i>.
1C	1.xx	5.15.113.0 or higher	Feb 10, 2021	Olek Bogush	<ul style="list-style-type: none"> Updated the controller title. Updated <i>Introduction</i> section
1B	1.xx	5.15.113.0 or higher	Sep 14, 2020	Olek Bogush	<ul style="list-style-type: none"> Added notes excluding Proprietary A PGN (61184) from customer's use in function blocks. Updated <i>CAN Standard Implementation</i> table, <i>CAN Input Signal</i> and <i>CAN Output Message</i> function blocks
1A	1.xx	5.15.113.0 or higher	July 17, 2020	Olek Bogush	<ul style="list-style-type: none"> Added weight in <i>General Specifications</i>
1	1.xx	5.15.113.0 or higher	June 23, 2020	Olek Bogush	<ul style="list-style-type: none"> Initial release

OUR PRODUCTS

AC/DC Power Supplies
Actuator Controls/Interfaces
Automotive Ethernet Converters
Battery Chargers
CAN Controls, Routers, Repeaters
CAN/WiFi, CAN/Bluetooth
Current/Voltage Converters
DC/DC Power Converters
Engine Temperature Scanners
Ethernet/CAN Converters,
Gateways, Switches
Fan Drive Controllers
Gateways, CAN/Modbus Protocols
Gyroscope Inclinometers
Hydraulic Valve Controllers
Inclinometers, Triaxial
I/O Controls
LVDT Signal Converters
Machine Controls
Modbus Controls
Motor Controls
Power Supplies, DC/DC, AC/DC
PWM Signal Converters/Isolators
Resolver Signal Conditioners
Service Tools
Signal Conditioners, Converters
Strain Gauge CAN Controls
Surge Suppressors

OUR COMPANY

Axiomatic provides electronic machine control components to the off-highway, commercial vehicle, electric vehicle, power generator set, material handling, renewable energy and industrial OEM markets. ***We innovate with engineered and off-the-shelf machine controls that add value for our customers.***

QUALITY DESIGN AND MANUFACTURING

Axiomatic in Canada has an ISO 9001:2015 design and manufacturing facility.

SERVICE

All products to be returned to Axiomatic require a Return Materials Authorization Number (RMA#) from sales@axiomatic.com. Please provide the following information when requesting an RMA number:

- Serial number, part number
- Hours of operation, description of problem
- Wiring set up diagram, application and other comments as needed

SAFE USE

All products should be serviced by Axiomatic. Do not open the product and perform the service yourself.



This product can expose you to chemicals which are known in the State of California, USA to cause cancer and reproductive harm. For more information go to www.P65Warnings.ca.gov.

DISPOSAL

Axiomatic products are electronic waste. Please follow your local environmental waste and recycling laws, regulations and policies for safe disposal or recycling of electronic waste.

WARRANTY, APPLICATION APPROVALS/LIMITATIONS

Axiomatic Technologies Corporation reserves the right to make corrections, modifications, enhancements, improvements, and other changes to its products and services at any time and to discontinue any product or service without notice. Customers should obtain the latest relevant information before placing orders and should verify that such information is current and complete. Users should satisfy themselves that the product is suitable for use in the intended application. All our products carry a limited warranty against defects in material and workmanship. Please refer to our Warranty, Application Approvals/Limitations and Return Materials Process as described on www.axiomatic.com/service.html.

CONTACTS

Axiomatic Technologies Corporation
5915 Wallace Street
Mississauga, ON
CANADA L4Z 1Z8
TEL: +1 905 602 9270
FAX: +1 905 602 9279
www.axiomatic.com
sales@axiomatic.com

Axiomatic Technologies Oy
Höytämöntie 6
33880 Lempäälä
FINLAND
TEL: +358 103 375 750
FAX: +358 3 3595 660
www.axiomatic.com
salesfinland@axiomatic.com