

USER MANUAL

2 Bipolar, 8 Universal Signal Input Controller, CAN (CANopen), Ethernet (Modbus TCP/IP), Two +5V References, DIN Rail Mount

P/N: AX032101

In Europe:
Axiomatic Technologies Oy
Höytämöntie 6
33880 Lempäälä - Finland
Tel. +358 103 375 750
Fax. +358 3 3595 660
www.axiomatic.fi

In North America:
Axiomatic Technologies Corporation
5915 Wallace Street
Mississauga, ON Canada L4Z 1Z8
Tel. 1 905 602 9270
Fax. 1 905 602 9279
www.axiomatic.com

ACRONYMS

ARP	Address Resolution Protocol
ASCII	American Standard Code for Information Interchange
AWG	American wire gauge
CAN	Controller Area Network
CE	Conformité Européenne (European Conformity)
CMOS	Complementary metal-oxide-semiconductor
DC	Direct Current
DIN	German Institute for Standardization
DM	Diagnostic message. Defined in J1939/73 standard
EA	Electronic Assistant. PC application software from Axiomatic
ECU	Electronic control unit
EEPROM	Electrically Erasable Programmable Read-Only Memory
EMI	Electromagnetic Interference
EN	European Standard
GPL	General Public License
ICMP	Internet Control Message Protocol
ID	Identifier
IEC	International Electrotechnical Commission
IEEE	Institute of Electrical and Electronics Engineers
IP	Internet Protocol or Ingress Protection (for housing)
ISO	International Organization for Standardization
LAN	Local Area Network
LED	Light-emitting diode
LoZ	Low resistance
LSB	Less Significant Byte
MAC	Media Access Control (address)
MDIX	Medium Dependent Interface Crossover (MDI-X)
PC	Personal Computer
PGN	Parameter Group Number. Defined in J1939/73 standard
PHY	Physical Layer Transceiver (Ethernet chip)
P/N	Part Number
PWM	Pulse-width modulation
RoHS	Restriction of Hazardous Substances
RTOS	Real-Time Operating System
SAE J1939	CAN-based higher-level protocol designed and supported by the Society of automobile Engineers (SAE)
S/N	Serial Number
TBD	To be determined
TCP	Transmission Control Protocol
UDP	User Datagram Protocol
UL	Underwriters Laboratories (safety organization)
USB	Universal Serial Bus
VDC	Volt Direct Current
UTP	Unshielded twisted pair

TABLE OF CONTENTS

1	INTRODUCTION.....	7
2	CONTROLLER DESCRIPTION	8
2.1	Hardware Block Diagram	8
2.2	Software Organization	9
2.3	Modbus TCP Interface	9
2.4	Discovery Protocol	10
2.5	LED Indicators	11
2.5.1	Ethernet LED	11
2.5.2	CAN/System LED	11
2.6	Default Settings.....	11
3	CONTROLLER LOGICAL STRUCTURE	12
3.1	Internal Signals	13
3.2	Output Signal Sources	13
3.3	Universal Inputs	14
3.3.1	Digital Input Modes	15
3.3.2	Analog Input Modes.....	17
3.3.3	Special Conditions	21
3.4	Binary Functions	22
3.5	Miscellaneous Function Block.....	25
3.5.1	Extra RPDO Messages.....	25
3.5.2	Startup	26
3.5.3	Global Parameters	26
3.6	Ethernet	27
4	Communication Objects (DS-301).....	28
4.1	1000h Device Type	29
4.2	1001h Error Register.....	29
4.3	1002h Manufacturer Status Object	29
4.4	1003h Pre-Defined Error Field	29
4.5	100Ch Guard Time	29
4.6	100Dh Life Time Factor	30
4.7	1010h Store Parameters.....	30
4.8	1011h Restore Parameters.....	30
4.9	1016h Consumer Heartbeat Time.....	31
4.10	1017h Producer Heartbeat Time.....	31
4.11	1018h Identity Object	31
4.12	1020h Verify Configuration.....	31
4.13	1029h Error Behavior	32
4.14	1400h RPDO 1 Communication Parameters	32
4.15	1401h RPDO 2 Communication Parameters	32
4.16	1402h RPDO 3 Communication Parameters	33
4.17	1600h RPDO 1 Mapping Parameters	33
4.18	1601h RPDO 2 Mapping Parameters	33
4.19	1602h RPDO 3 Mapping Parameters	33
4.20	1800h TPDO 1 Communication Parameters.....	34
4.21	1801h TPDO 2 Communication Parameters.....	34
4.22	1802h TPDO 3 Communication Parameters.....	34

4.23	1803h TPDO 4 Communication Parameters	35
4.24	1804h TPDO 5 Communication Parameters	35
4.25	1A00h TPDO 1 Mapping Parameters	35
4.26	1A01h TPDO 2 Mapping Parameters	36
4.27	1A02h TPDO 3 Mapping Parameters	36
4.28	1A03h TPDO 4 Mapping Parameters	36
5	Application Objects (DS-404 Inputs)	37
5.1	6000h DI Read State 8 Input Lines	37
5.2	6002h DI Polarity 8 Input Lines	37
5.3	7100h AI Input Field Value	38
5.4	6110h AI Sensor Type	38
5.5	6112h AI Operating Mode	39
5.6	7120h AI Input Scaling 1 FV	39
5.7	7121h AI Input Scaling 1 PV	40
5.8	7122h AI Input Scaling 2 FV	40
5.9	7123h AI Input Scaling 2 PV	41
5.10	7124h AI Input Offset	41
5.11	7130h AI Input Process Value	42
5.12	6132h AI Decimal Digits PV	42
6	Manufacturer Objects	43
6.1	2020h DI Pull Up Down Mode 1 Input Line	45
6.2	2030h DI Debounce Filter	45
6.3	2040h DI Debounce Time	46
6.4	2050h AI Frequency Averaging	46
6.5	2100h AI Input Range	47
6.6	2101h AI Analog LoZ Input	47
6.7	2102h AI Decimal Digits FV	48
6.8	2103h AI Analog Input Filter	48
6.9	3000h BF Binary Output FV	49
6.10	300Ah BF Output Function	49
6.11	300Bh BF Output Scale	50
6.12	300Ch BF Output Offset	50
6.13	30x0h BF Signal Source ¹	51
6.14	30x1h BF Is Default Signal ¹	51
6.15	30x2h BF Default Signal Value ¹	51
6.16	30x3h BF Unary Function Name ¹	51
6.17	30x4h BF Unary Input Scale ¹	52
6.18	30x5h BF Unary Function Offset ¹	52
6.19	4000h ENET MAC Address	52
6.20	4001h ENET IP Address	52
6.21	4002h ENET Subnet Mask	53
6.22	4003h ENET Default Gateway	53
6.23	4005h ENET Modbus Port	53
6.24	4005h ENET Modbus Timeout	53
6.25	2500h EC Extra Received PV	54
6.26	2502h EC Decimal Digits PV	54
6.27	2520h EC Scaling 1 PV	55
6.28	2522h EC Scaling 2 PV	55
6.29	5010h Constant Field Value 1	56

6.30	5020h Power Supply FV	56
6.31	5030h CPU Temperature FV	56
6.32	5040h Constant Field Value 2	56
6.33	5500h SPP Command	56
6.34	5510h SPP Response.....	57
6.35	5550h Enable Auto Update	57
6.36	5555h Start In Operational Mode	57
6.37	55AAh Start Bootloader	57
6.38	5B50h Change Baud Rate	57
6.39	5B51h Change Node ID	58
7	CONTROLLER CONFIGURATION.....	59
7.1	Modbus Configuration	59
7.2	CANopen Configuration	59
8	TECHNICAL SPECIFICATIONS	60
8.1	Power Supply	60
8.2	Bipolar Inputs	60
8.3	Universal Inputs	61
8.4	Voltage Reference Outputs.....	62
8.5	Ethernet Interface	62
8.6	CAN Interface	62
8.7	General Specifications	63
8.8	Enclosure	64
8.9	Electrical Connections	64
8.10	Installation.....	64
9	MODBUS ADDRESS MAP	65
10	THIRD-PARTY SOFTWARE LICENSE NOTICES	126
11	VERSION HISTORY	127

1 INTRODUCTION

The following user manual describes architecture, functionality, configuration parameters and flashing instructions for the 2 Bipolar, 8 Universal Signal Input Controller with CANopen CAN and Modbus TCP/IP Ethernet communication links. It also contains controller technical specifications and installation instructions to help users build a custom solution on the base of this controller.

The user should check whether the application firmware installed in the controller is covered by this user manual. It can be done through CAN bus using Axiomatic Electronic Assistant® (EA) software or using Ethernet Modbus TCP/IP link.

The user manual is valid for application firmware with the same major version number as the user manual. For example, this user manual is valid for any converter application firmware V1.xx. Updates specific to the user manual are done by adding letters: A, B, ..., Z to the user manual version number.

It is assumed, that the user is familiar with Modbus and CANopen groups of standards. The terminology from these standards is widely used in this manual.

2 CONTROLLER DESCRIPTION

The controller is designed to convert physical signals from bipolar and universal inputs into CANopen signals and input register data for the Modbus TCP interface. The bipolar and universal inputs accept voltage, current, resistance (only universal inputs), frequency, PWM duty cycle, and discrete voltage levels. Two independent +5V reference voltage outputs can be used to power user equipment.

The CANopen network can operate at standard 125kbit/s and supports the following baud rates: 10, 20, 50, 250, 500, 800, and 1000kbit/s. The required baud rate can be set by setting writing the object 5B50.

The Modbus TCP/IP interface runs on a standard 10/100 Mbit/s Ethernet link providing up to 5 simultaneous client connections.

The controller can be configured through a set of configuration parameters over CAN or Ethernet interface to fit the user-specific application requirements.

2.1 Hardware Block Diagram

The controller contains 2 bipolar, 8 universal signal inputs, one CAN and one Ethernet port, two +5V reference voltage outputs, and a protected power supply. An embedded 32-bit microcontroller provides necessary processing power to the controller.

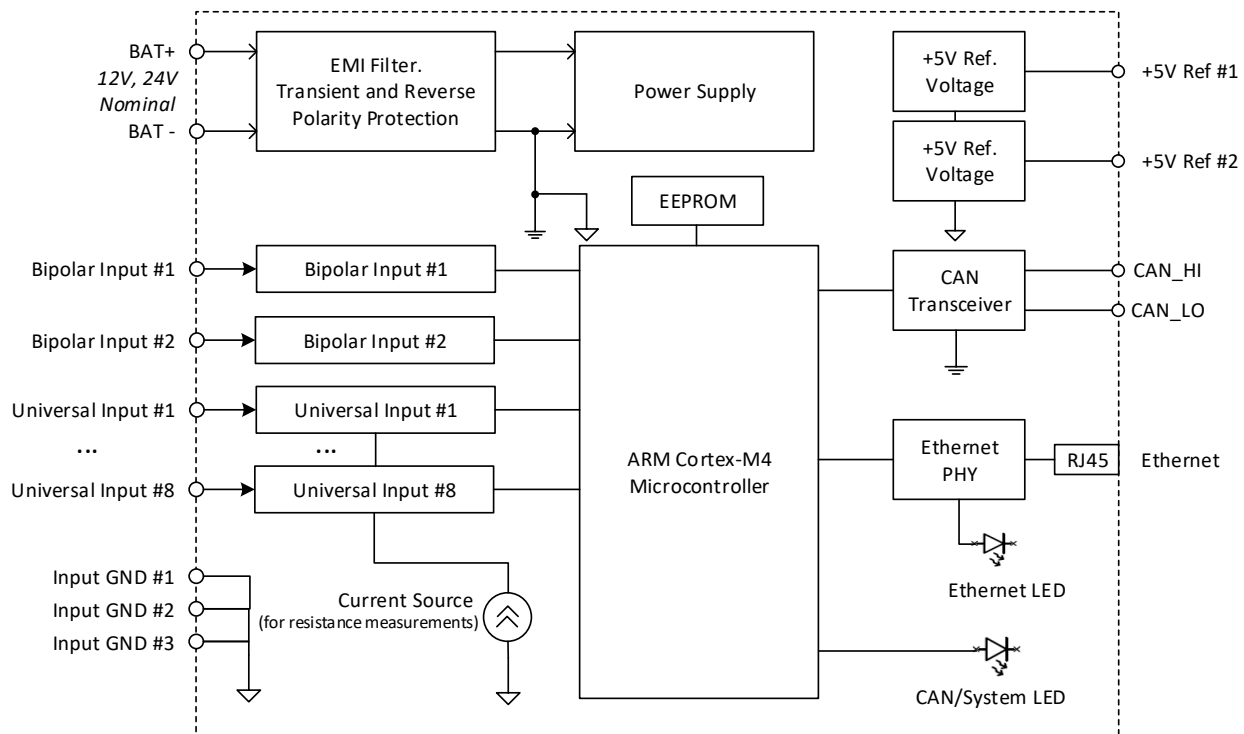

Figure 1. The Controller Hardware Block Diagram

The controller has a wide range of protection features including a transient and reverse polarity protection, see TECHNICAL SPECIFICATIONS section.

2.2 Software Organization

The controller belongs to a family of Axiomatic smart controllers with configurable internal architecture. This architecture allows building of a signal converting algorithm based on a set of predefined internal configurable function blocks without the need of a custom software.

All CANopen objects supported by the AX032101 are user configurable using standard commercially available tools that can interact with a CANopen ® Object Dictionary via an .EDS file.

2.3 Modbus TCP Interface

The Modbus TCP/IP interface¹ runs over a standard 10/100 Mbit/s Ethernet link. The controller is presented as a slave device (a server) on the Modbus network. It supports with up to 8 simultaneous client connections from master devices.

¹The interface is compliant with:

- MODBUS Messaging on TCP/IP Implementation Guide V1.0b. Modbus Organization. October 24, 2006, 46p.
- MODBUS Application Protocol Specification V1.1b3. Modbus Organization. April 26, 2012, 50p.

The following Modbus functions are supported by the controller.

Table 1. Modbus Functions Supported by the Controller

Name	Function Code/Subcode	Description
Read Discrete Inputs	2	Reads values of the universal inputs when they are in the discrete voltage level mode
Read Input Registers	4	Reads values of the universal inputs
Read Holding Registers	3	Reads one or several configuration parameters
Write Single Register	6	Writes a configuration parameter
Write Multiple Registers	16	Writes one or several configuration parameters
Read/Write Multiple Registers	23	Writes and then reads configuration parameters
Encapsulated Interface Transport	43/14	Reads Device Identification

The Modbus addresses are presented in the MODBUS ADDRESS MAP section.

The Unit Identifier in the Modbus TCP header is ignored.

Floating-point variables are presented in a standard IEEE 754 single-precision 32-bit format, most significant word first. Double-word 32-bit integers are also presented with the most significant word first.

Reading and writing operations on variables occupying more than one word (a 16-bit Modbus register) are buffered. The buffering is made transparent to the user. However, it should be taken into consideration that writing to a non-volatile memory is not performed until all registers assigned to the variable are written. The writing operation should be performed without

overlapping (writing to the same register twice) and without breaking the writing operation sequence with a reading operation or a writing operation to a different variable.

The Modbus functions “Write Multiple Registers” and “Read/Write Multiple Registers”, when they include all registers assigned to a variable in one function call, meet the abovementioned writing requirements.

The Modbus writing operations are subject to a validity check. If a configuration parameter value is not in a valid range, the Modbus operation will succeed, but the configuration parameter will not be written.

The following device identification information can be read using the Encapsulated Interface Transport 43/14 function.

Table 2. Modbus Device Identification

Object ID	Object Name	Description
0x00	VendorName	“Axiomatic”
0x01	ProductCode	Controller P/N. “AX032101”
0x02	MajorMinorRevision	Current firmware version. For example, “V1.00”
0x03	VendorUrl	“www.axiomatic.com”
0x04	ProductName	“IO Controller”
0x05	ModelName	Same as ProductCode. Controller P/N. “AX032101”
0x06	UserApplicationName	Firmware description. Depends on the firmware version. For V1.xx: “2 Bipolar, 8 Universal Signal Input Controller, CANopen, Ethernet”
0x80	SerialNumber	Private Object. Controller S/N. For example, “0012020016”

All device identification objects are presented in ASCII strings.

2.4 Discovery Protocol

The controller supports an Axiomatic proprietary protocol that allows the discovery of Axiomatic controllers on a LAN by sending a global UDP request on port 35100¹.

¹ O. Bogush, "Ethernet to CAN Converter Discovery Protocol. CAN-ENET, AX140900, Project 15129. Document version: 1," Axiomatic Technologies Corporation, October 26, 2016.

Axiomatic provides a Windows console application `AxioDisc.exe` that can be used to discover the controller. The application shows the controller MAC address, IP address, web server port (not used), device port (Modbus port), device port type (TCP), the controller part number and serial number, see Figure 2.

The `AxioDisc.exe`. application is available upon request.

```

Command Prompt
-----
Program: AxioDisc V1.0.0
(c) 2016, Axiomatic Technologies Corporation

This program discovers Axiomatic units on the LAN
using: "Ethernet to CAN Converter Discovery Protocol V1".
-----

          MAC          IP    WebPort    DevPort    DevPortType          P/N          S/N
-----
B4:37:D1:A0:00:01    192.168.0.34          0          502          TCP          AX032100    0012020016

```

Figure 2. Discovery of the Controller on LAN Using AxioDisc.exe Application

2.5 LED Indicators

The controller has two LED Indicators: Ethernet and CAN/System LEDs.

2.5.1 Ethernet LED

The Ethernet LED is a bi-color green-yellow indicator that shows Ethernet link and speed status. The green color presents the Ethernet link status and the yellow color – the Ethernet speed, see the table below.

Table 3. Ethernet LED

LED	Description
Off	No Link
Green	Link On. Speed 10Mbit/s
Blinking Green	Activity. Speed 10Mbit/s
Green and Yellow	Link On. Speed 100Mbit/s
Blinking Green and Yellow	Activity. Speed 100Mbit/s

The Ethernet bi-color LED is hard wired to the Ethernet PHY.

2.5.2 CAN/System LED

The CAN/System LED is a bi-color green-red indicator that shows CAN bus status and some global system conditions, see the table below.

Table 4. CAN/System LED

LED	Status	Description
Constant Green	CAN	CAN link is established
Blinking Green		CAN activity. CAN communication is running
Constant Red		CAN error
Flashing Red	System	Unrecoverable system error. Device failure
Flashing Green/Red		Device is in the bootloader mode

2.6 Default Settings

The controller *Bipolar* and *Universal Inputs* are configured to input voltages in the 0...5V voltage range by default. These voltages can be read through Modbus interface.

The ECU Starts in PRE-OPERATIONAL mode. All objects can be configured to accommodate user-specific application requirements, see **Error! Reference source not found.** in Communication, Manufacturer, or Application Objects section.

3 CONTROLLER LOGICAL STRUCTURE

The controller is internally organized as a set of function blocks, which can be individually configured and arbitrarily connected together to achieve the required system functionality, see Figure 3.

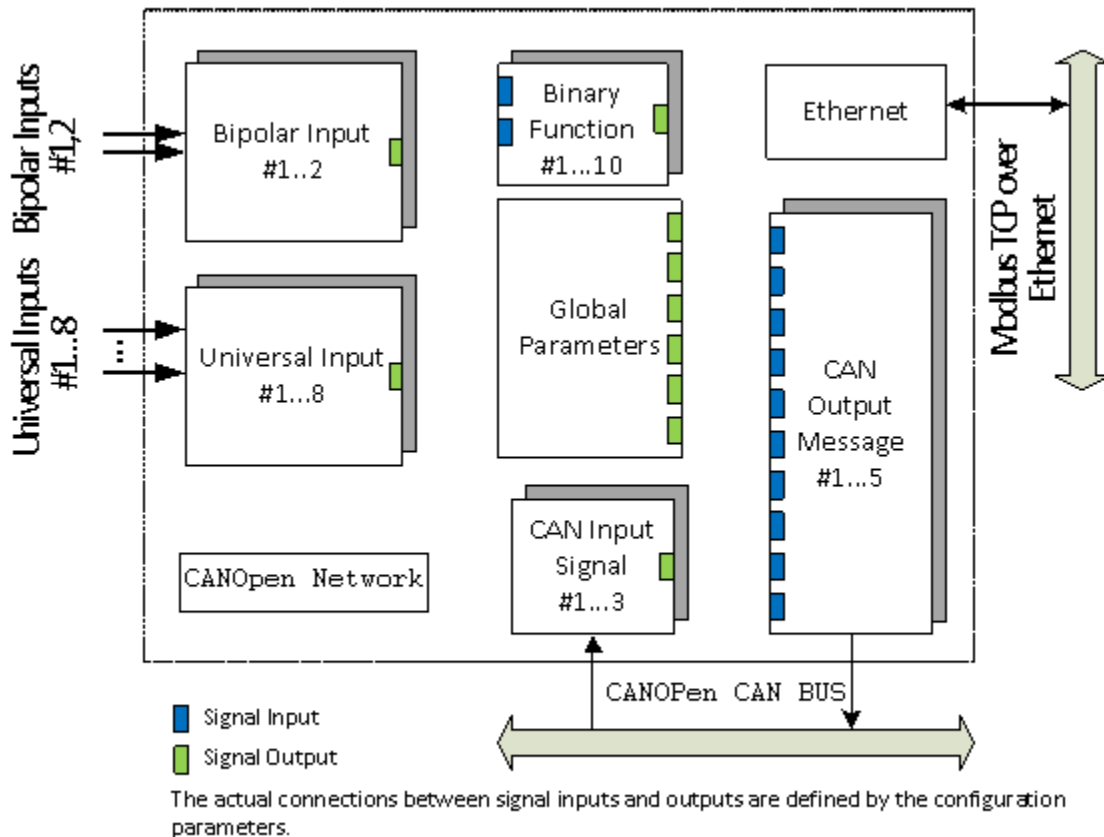

Figure 3. The Controller Logical Block Diagram

Each function block is absolutely independent and has its own set of communication, application, and manufacturer objects. The configuration parameters can be viewed and changed through CAN bus by using standard commercially available tools that can interact with a CANopen® Object Dictionary via an .EDS file or over Modbus interface.

The *Bipolar* and *Universal Input* function blocks present the controller physical input channels. Both function blocks can measure multiple physical parameters. The difference between them is in voltage and resistance measurements, see the table below.

Table 5. Bipolar vs Universal Function Blocks

Function Block	Voltage Measurements	Resistance Measurements
Bipolar	Bipolar	Absent
Universal	Unipolar, only positive voltages	Present

The Modbus interface is presented by the *Ethernet* function block that contains Modbus TCP/IP network settings.

For data processing, when required, there are ten *Binary Function* blocks. They can take two input signals and combine them together in one output signal using different functions.

The converter also has a *Global Parameters* function block containing four constant output signals and other auxiliary outputs.

3.1 Internal Signals

The controller objects can communicate with each other through internal signal inputs and outputs. Each signal input of one function block can be connected to any signal output of another function block using an appropriate configuration parameter. There is no limitation on the number of signal inputs connected to one signal output.

When a signal input is connected to a signal output, data from the signal output of one function block is available on the signal input of another function block.

Function block signals can be “Undefined”, “Discrete” or “Continuous”. The “Undefined” signal type is reserved for a disconnected signal source or a no-signal transient condition. The “Discrete” and “Continuous” signal types are used to communicate discrete and continuous signals, respectively.

Discrete signals present data with a finite number of states. They are stored in four-byte unsigned integer variables that can present any state in the 0...0xFFFFFFFF range.

Continuous signals present continuous data, usually physical parameters. They are stored in single-precision floating-point variables. The continuous signals are not normalized and usually present data in physical units.

When a discrete signal output is connected to a continuous signal input, the discrete signal is converted into a positive continuous signal of the same value.

When a continuous signal output is connected to a discrete signal input, the following rules apply. A positive continuous signal is converted into the same value discrete signal. A fractional part of the continuous signal is truncated. If the continuous signal is above the maximum discrete signal value, it is saturated to the maximum discrete signal value: 0xFFFFFFFF. All negative continuous signals are converted into zeros.

3.2 Output Signal Sources

The controller output signal sources of all function blocks are presented in the table below.

Table 6. Controller Signal Sources

Signal Source Number	Signal Name	Signal Type
0	Not Connected	Undefined
1	Bipolar Input #1	Discrete or Continuous ¹

Signal Source Number	Signal Name	Signal Type
2	Bipolar Input #2	Discrete or Continuous ¹
3	Unipolar Input #1	Discrete or Continuous ¹
4	Unipolar Input #2	Discrete or Continuous ¹
5	Unipolar Input #3	Discrete or Continuous ¹
6	Unipolar Input #4	Discrete or Continuous ¹
7	Unipolar Input #5	Discrete or Continuous ¹
8	Unipolar Input #6	Discrete or Continuous ¹
9	Unipolar Input #7	Discrete or Continuous ¹
10	Unipolar Input #8	Discrete or Continuous ¹
11	Binary Function #1	Continuous
12	Binary Function #2	Continuous
13	Binary Function #3	Continuous
14	Binary Function #4	Continuous
15	Binary Function #5	Continuous
16	Binary Function #6	Continuous
17	Binary Function #7	Continuous
18	Binary Function #8	Continuous
19	Binary Function #9	Continuous
20	Binary Function #10	Continuous
21	CAN Input Signal #1	Any ²
22	CAN Input Signal #2	Any ²
23	CAN Input Signal #3	Any ²
24	Global Discrete Constant Signal	Discrete
25	Global Continuous Constant Signal	Continuous
26	Global Constant Signal = 0	Continuous
27	Global Constant Signal = 1	Continuous
28	Supply Voltage	Continuous
29	Microcontroller Temperature	Continuous

¹ Depends on the *Input Parameter*.

² Depends on the *Signal Type* configuration parameter.

3.3 Universal Inputs

The unit has overall 10 inputs, 2 of which are bipolar (inputs 1 and 2) and 8 are unipolar (inputs 3...10). All the differences will be mentioned later in this section. The bipolar and unipolar input types are shown on the Figure 4.

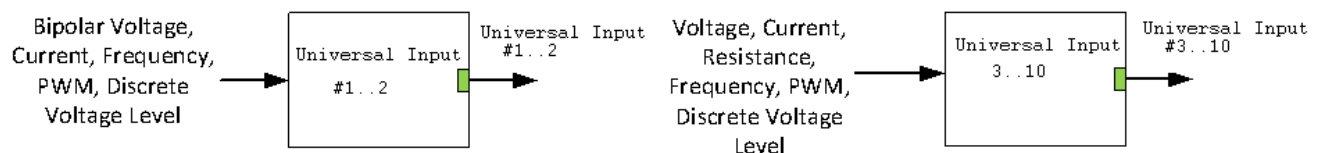

Figure 4. Universal and Bipolar Input Types

3.3.1 Digital Input Modes

The digital input (DI) function block only becomes applicable on the input when object 6112h **AI Operation**, is set to a digital input response.

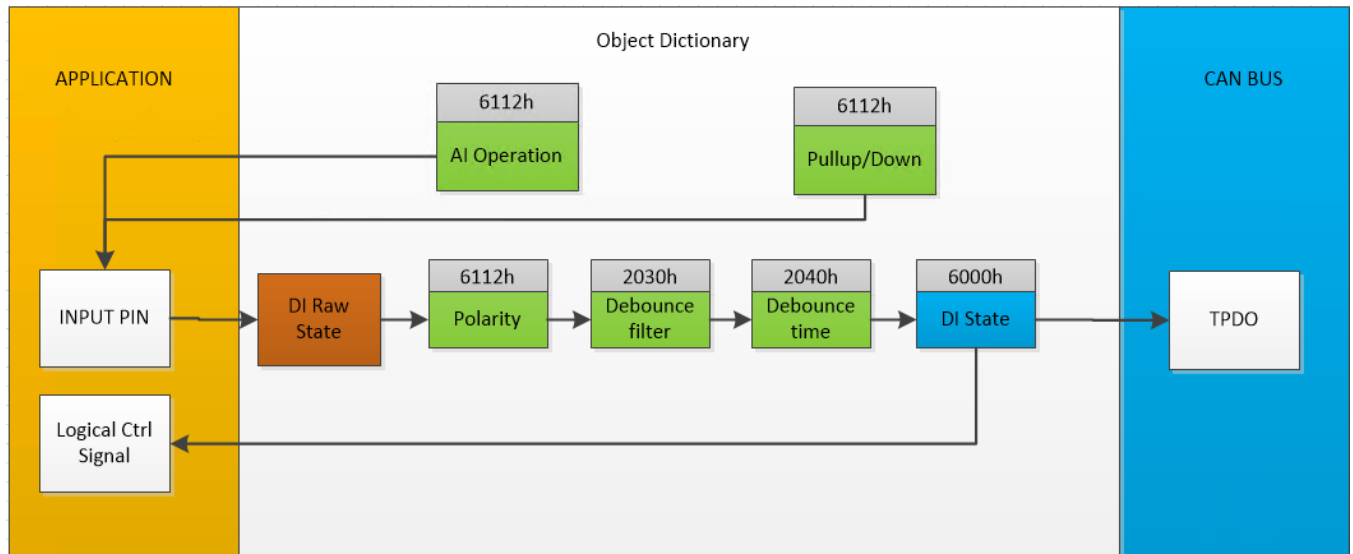

Figure 5 – Digital Input Objects

When object 6112h is set to 10 = *Digital Input*, object 2020h **DI Pull-up/Pull-down Mode** will determine the configuration of the internal Pull-up/Pull-down resistors. The options for object 2020h are shown in Table 7, with the default **bolded**.

Table 7 – DI Pullup/Down Options

Value	Meaning
0	Pullup/Down Disabled (high impedance input)
1	10kΩ Pullup Resistor Enabled
2	10kΩ Pulldown Resistor Enabled

Figure 6 shows the hysteresis on the input when switching a discrete signal. A digital input can be switched up to +Vcc

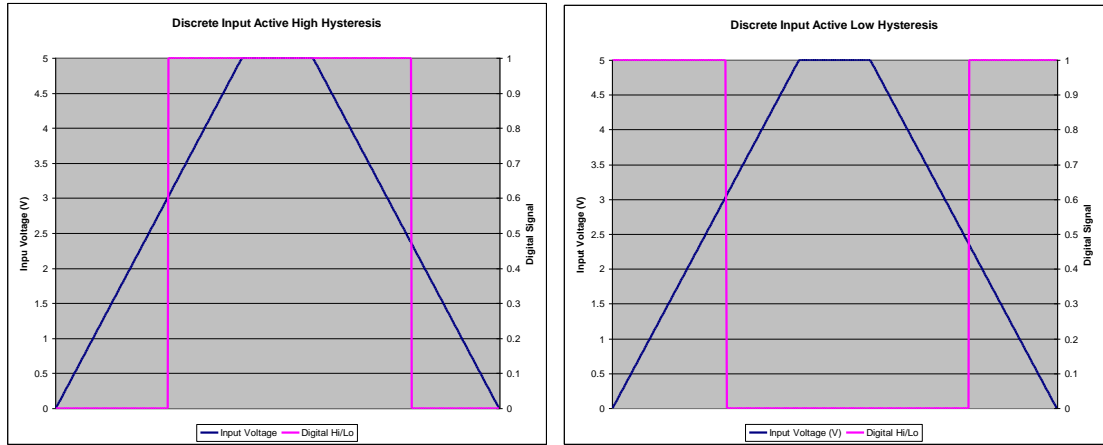

Figure 6 – Discrete Input Hysteresis

Once the raw state has been evaluated, the logical state of the input is determined by object 6002h **DI Polarity 8 Input Lines**. The options for object 6002h are shown in Table 8. The state of the DI will be written to read-only object 6000h **DI Read State 8 Input Lines**. By default, normal on/off logic is used.

Table 8 – Object 6002h DI Polarity 8 Input Lines Options

Value	Meaning
0	Normal On/Off
1	Inverse On/Off

The format to write to object 6002h is as follows:

Sub-index 1 will determine the following inputs polarities

Bit 7	Bit 6	Bit 5	Bit 4	Bit 3	Bit 2	Bit 1	Bit 0
UI8	UI7	UI6	UI5	UI4	UI3	UI2	UI1
-	-	-	-	-	-	UI10	UI9

As per the format of object 6002h, the bits in object 6000h **DI Read State 8 Input Lines** will be written to represent the same inputs' states.

There is another type of 'digital' input that can be selected when 6112h is set to 20 = Analog On/Off. However, in this case, the input is still configured as an analog input, and therefore the objects from the Analog Input (AI) block are applied instead of those discussed above. Here, objects 2020h, 2030h and 6030h are ignored, and 6000h is written as per the logic shown in Figure 7. In this case, the MIN parameter is set by object 7120h **AI Scaling 1 FV**, and the MAX is set by 7122h **AI Scaling 2 FV**. For all other operating modes, object 6000h will always be zero.

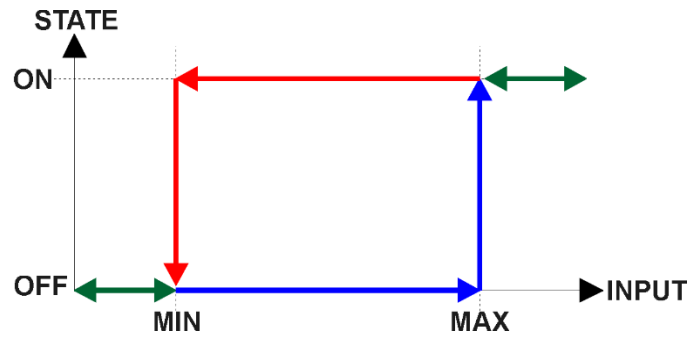

Figure 7 – Analog Input Reads as Digital

The *Universal Inputs* can accept discrete voltage levels. The user should specify the input polarity and define whether the pull-up/pull-down resistor is necessary on the input.

When the “10kOhm Pull-Up” is selected, the pull-up resistor is connected to the internal +14V power supply.

The input states are sampled every 1ms. If debouncing is required, it is set by the *Discrete Input Debounce Time* configuration object 2040h. If the *Discrete Input Debounce Time* is zero, the discrete voltage level input is not debounced.

The *Universal Input* function block translates physical input signals into the internal function block output signal that can be used by other function blocks of the controller. In comparison with *Bipolar Inputs*, *Unipolar Inputs* can measure resistance, but the voltage measurements are limited to unipolar positive voltages.

3.3.2 Analog Input Modes

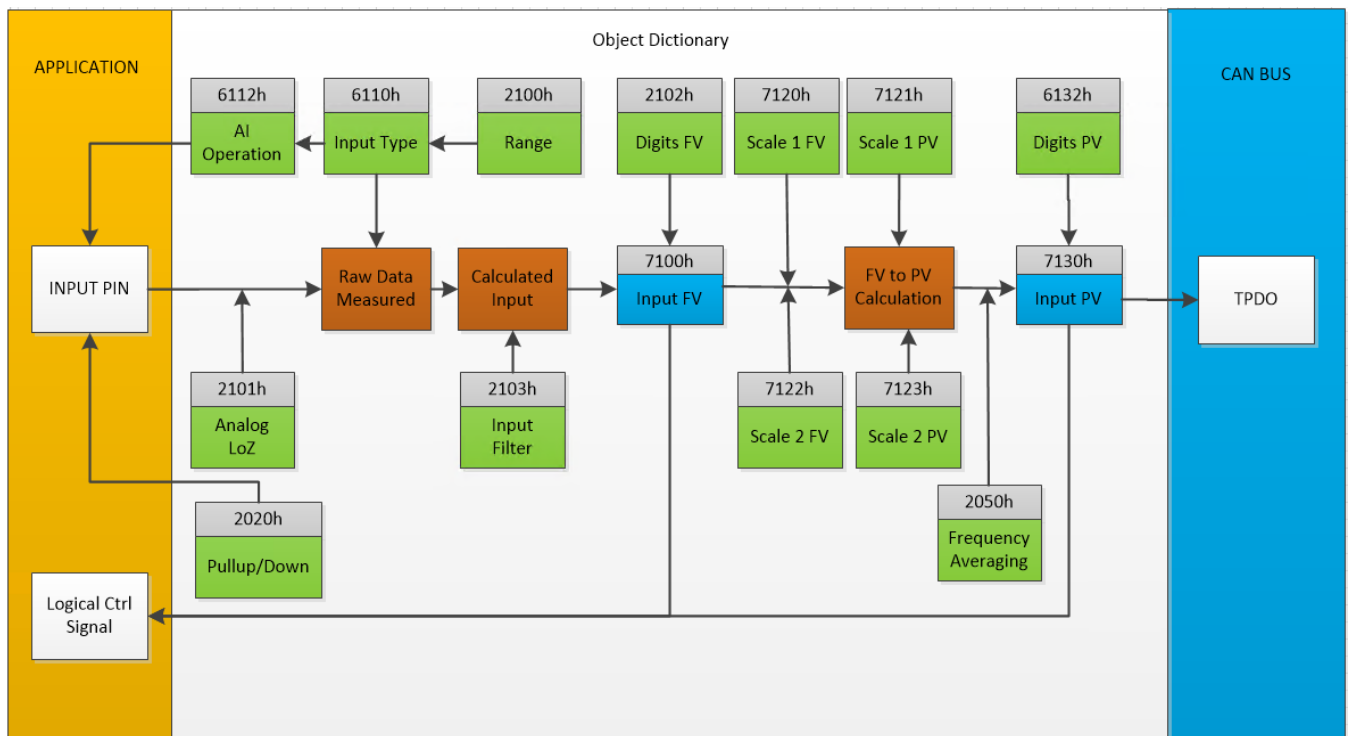

Figure 8 – Analog Input Objects

Object 6112h **AI Operating Mode** determines whether the AI or DI block is associated with an input. The options for object 6112h are shown in Table 9. No values other than what are shown here will be accepted.

Table 9 – Object 6112h - AI Operating Mode Options

Value	Meaning
0	Channel Off
1	Normal Operation (analog)
10	Digital Input (on/off)
20	Analog and On/Off

The most important object associate with the AI function block is object 6110h **AI Sensor Type**. By changing this value, and associated with its object 2100h **AI Input Range**, other objects will be automatically updated by the controller. The options for object 6110h are shown in Table 10, and no values other than what are shown here will be accepted. The inputs are setup to measure voltage by default.

Note: The resistive input works only for unipolar inputs, and the ECU will not accept 100 in case of bipolar inputs.

Table 10 – Object 6110h - AI Sensor Type Options

Value	Meaning
40	Voltage Input
50	Current Input
60	Frequency Input (or RPM)
120	Resistive
10000	PWM Input

The allowable ranges will depend on the input sensor type selected. Table 11 shows the relationship between the sensor type, and the associated range options. The default value for each range is bolded, and object 2100h **AI Range** will automatically be updated with this value when 6110h is changed. The grayed cells mean that the associate value is not allowed for the range object when that sensor type has been selected.

Table 11 – AI Input Range Options Depending on Sensor Type

Value	Voltage	Current	Frequency	Resistive
0	0 to 5V	0 to 20mA	100Hz to 10kHz¹	Auto Range³
1	0 to 10V	4 to 20mA	10Hz to 1kHz	0Ohm to 250Ohm ³
2	-5 to +5V ²		1Hz to 100Hz	250Ohm to 2.5kOhm ³
3	-10 to +10V ²			2.5kOhm to 25kOhm ³
4				25kOhm to 250kOhm ³

1. For bipolar input 1 (Universal Input 1) There is only one range 1Hz...10kHz that is set by default.

2. Available only for bipolar inputs

3. Available only for unipolar inputs

The unipolar inputs can measure slowly changing input resistance, for example, a signal coming from a resistive temperature sensor.

The resistance measurements can be done in an auto-range or a predefined range mode set by the *Resistance Range* configuration parameter.

When the object 2100h **AI Input Range** is set to 0, and object 6110h **AI Sensor Type** is set to 100, the auto-range is enabled. It is a special algorithm is used to dynamically switch between resistance ranges to ensure that the resistance value is measured with the best accuracy and resolution, see the table below.

Table 12. Resistance Ranges as a Function of Input Resistance in the Auto Range Mode

Input Resistance	Resistance Range	
	Low-to-High Resistance Change	High-to-Low Resistance Change
< 225 Ohm	0...250Ohm	
225...275Ohm	0...250Ohm	0...2.5kOhm
275Ohm...2.25kOhm	0...2.5kOhm	
2.25kOhm...2.75kOhm	0...2.5kOhm	0...25kOhm
2.75kOhm...22.5kOhm	0...25kOhm	
22.5kOhm...27.5kOhm	0...25kOhm	0...250kOhm
>27.5kOhm	0...250kOhm	

If switching between the measurement ranges is not desirable or it is necessary to reduce the measurement time, the *Resistance Range* can be set to one of the predefined measurement ranges.

The *Analog Input Filter* configuration parameter can be used to reduce the measurement noise. However, it can also add a delay that can be significant when several universal inputs are used to measure resistance.

There is only one current source shared with all *Universal Inputs* for resistance measurements, see Figure 1. When more then one *Universal Input* is used to measure resistance, the current source is switched between inputs dramatically increasing the measurement time, see the table below.

Table 13. Universal Input Resistance Measurement Delay

Resistance Measurement	Measurement Delay
No channel or range switching	0 – No delay
Range switching only	$\begin{cases} T_{sw} + T_s, & \text{during range switching only} \\ 0, & \text{all other time – no delay} \end{cases}$ $T_{sw} = 30ms - \text{switching time}, T_s - \text{analog filter settling time}$
Channel switching (with or without range switching)	$\sum_{n=1}^N (T_{sw} + T_{s_n}), \quad N > 1, \quad N - \text{number of channels}$ $n - \text{channel number}$

For example, if 5 universal inputs are used to measure resistance and *Analog Input Filter* is set to “Both: 60Hz and 50Hz Noise Rejection” in all universal inputs, the total delay between consequent measurements will be $5 * (30 + 396.7) = 2133.5 \text{ ms}$ or more than 2 seconds.

Objects 2020h **DI Pull-up/Pull-down Mode** is used with frequency and PWM sensor types.

Object 2020h **DI Pull-up/Pull-down Mode** will determine the configuration of the internal Pull-up/Pull-down resistors. The options for object 2020h are shown in Table 7, with the default bolded.

When a frequency or PWM signal presents a slowly changing parameter, setting an additional moving average filter using the *Frequency/PWM Averaging* configuration parameter can be helpful in smoothing the results of the input measurements. Object 2050h **AI Frequency Averaging** has the parameters shown in the table below.

Table 14 – Object 2050h - AI Frequency Averaging

Value	Meaning
0	Averaging OFF
1	Averaging 3 Readings
2	Averaging 5 Readings
3	Averaging 10 Readings

The user can set the object 2102h **AI Analog Input Filter** to reduce noise in voltage and other analog signal measurements. The filter is designed to suppress noise from industrial offline voltages. Even when the analog input filter is disabled, the minimum signal filtering is performed by the function block. The parameters of the analog input filter are presented below.

Table 15. Universal Input Analog Input Filter Parameters

Analog Input Filter	Cut-off Frequency (at -3dB)	Settling Time (to 100% of Final Value)	Output Signal Update Rate
Disabled ¹	70Hz	10ms	1.67ms
50Hz Noise Rejection	12Hz	76.7ms	3.33ms
60Hz Noise Rejection	14Hz	63.3ms	3.33ms
Both: 60Hz and 50Hz Noise Rejection	2.3Hz	396.7ms	16.67ms

¹ Minimum filtering is still performed.

The options for object 2102h **AI Analog Input Filter** are shown in the Table 16.

Table 16 – Object 2050h - AI Analog Input Filter

Value	Meaning
0	Input Filter OFF
1	Input Filter 50Hz
2	Input Filter 60Hz
3	Input Filter 50-60Hz

To avoid an influence of ghost voltages, the *Voltage LoZ Input* configuration parameter can be activated. This will reduce the accuracy of voltage measurements due to the influence of the 10kOhm pull-down shunt resistor and should be used only after careful consideration of the shunt resistor influence on the measured circuit. The object 2101h **AI Analog LoZ Input** will determine the state of pull-down resistor. If the value of this object is set to 0, then the pull-down resistor is disabled; to enable it, the 1 should be written in this object.

3.3.3 Special Conditions

Frequencies below the Minimum Frequency value will be measured as zero and frequencies above the Maximum Frequency value will saturate at the Maximum Frequency based on the values stored in object 6110h **AI Sensor Type** and 2100h **AI Input Range**, see Table 17 and Table 18.

Table 17. Maximum, Minimum Frequencies and Maximum Recovery Time for Universal Inputs

Frequency Range	Counter	Minimum Frequency	Maximum Frequency	Maximum Recovery Time
100Hz...10kHz	16-bit	91.55Hz	12.5kHz	10.9ms
10Hz...1kHz		9.155Hz	1.25kHz	109ms
1Hz...100Hz		0.9155Hz	125Hz	1.09s

Frequencies above the Maximum Frequency value will switch the input to the Recovery state. The input will stay in the Recovery state until the upcoming counter saturation event when the frequency will be measured again. The input will leave the Recovery state if the measured frequency value is below the Maximum Frequency.

Table 18. Frequency and PWM Measurements for Universal Inputs. Special Conditions

Input Mode	Signal Frequency (F_s)			
	$F_s = 0$ Zero Frequency (DC)	$0 < F_s < F_{min}$ Below Minimum Frequency F_{min}	$F_{min} \leq F_s \leq F_{max}$ Working Frequency	$F_s > F_{max}$ Above Maximum Frequency F_{max}
Measured Frequency F_m	$F_m = 0$	$F_m = 0$	$F_m = F_s$	$F_m = F_{max}$ Recovery state
Measured PWM Duty Cycle D_m	$D_m = \{0, 100\}$	Undefined (not allowed)	$D_m = D_s$, D_s – signal duty cycle	$D_m = 0$ Recovery state

The time between two consequent counter saturation events defines the Maximum Recovery Time, see Table 17. This time is the maximum transient time when the measured frequency will stay equal to the Maximum Frequency value.

When the PWM signal is absent, the duty cycle is measured as 0 or 100% based on the voltage level on the input and the selected polarity in object 6002h **DI Polarity 8 Input Lines**. The voltage level is sampled on the counter saturation events until the PWM signal is back on the input.

The transient time between the PWM signal duty cycle and the duty cycle of the DC level when the signal disappears can be up to the Maximum Recovery Time. During the transient time, the measured value will stay equal to the last measured value of the PWM signal duty cycle.

The PWM input signal with a frequency above zero but below the Minimum Frequency value is not allowed. The duty cycle will not be measured, instead, it will be jumping between 0% and 100% depending on the voltage level at the input on the counter saturation events.

When the PWM input signal frequency exceeds the Maximum Frequency value, the input goes into the Recovery state and the PWM duty cycle is measured as 0%. Similar to frequency measurements, the input will stay in the Recovery state for up to the Maximum Recovery Time before the duty cycle is measured again.

3.4 Binary Functions

There are ten *Binary Function* blocks available to the user for performing simple data conversions. Each *Binary Function* block has two signal inputs and one signal output.

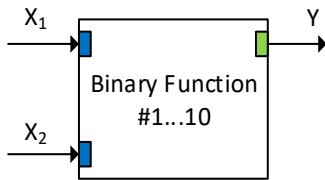

Figure 9. Binary Function Block

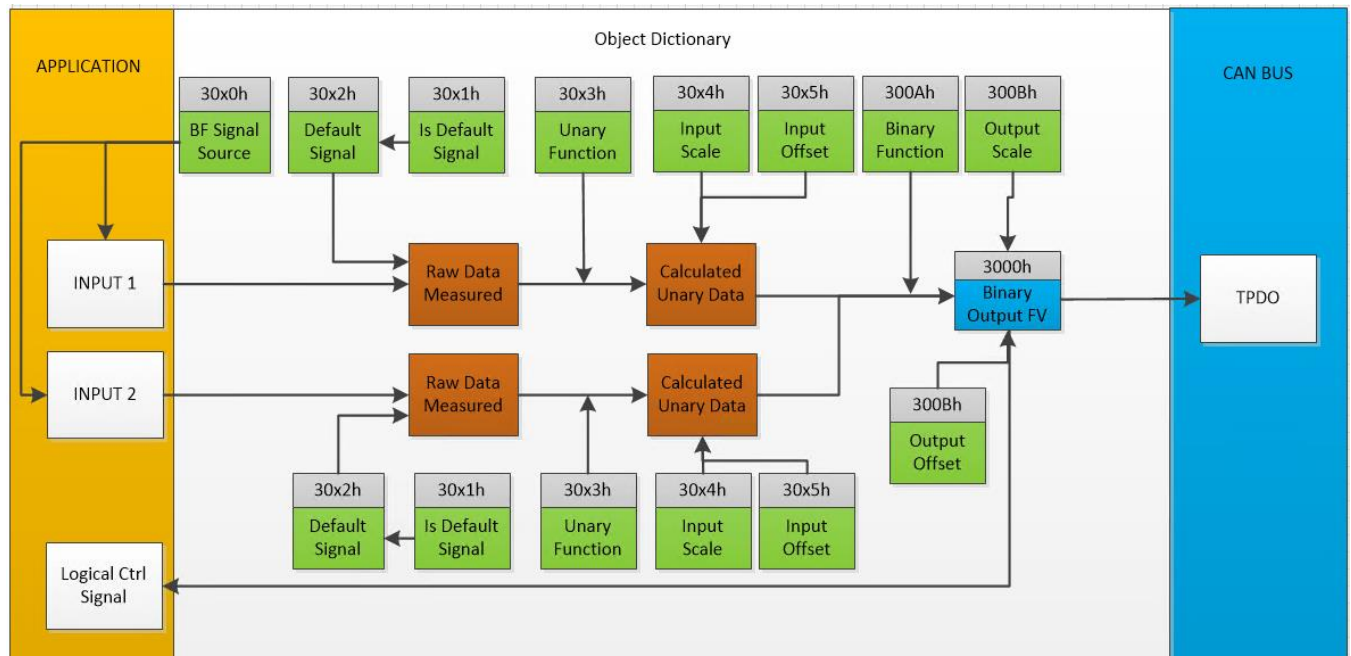

Figure 10 – Binary Function Objects

The *Binary Function* block performs the following data conversion:

$$Y = A \cdot F[a_1 \cdot f_1(X_1) + b_1; a_2 \cdot f_2(X_2) + b_2] + B, \quad n = 1,2; \quad (1)$$

where:

- X_n – Input signal;
- $f_n(X_n)$ – Unary function;
- a_n – Scale;
- b_n – Offset;
- $F[x; y]$ – Binary Function;
- A – Output Scale;
- B – Output Offset.

The function block input signals can be undefined. The user can specify a default signal value that will be used when the signal is not defined. If the default signal value is not specified, the output signal of the function block will become undefined too. The object 30x2h **BF Unary**

Function Name is used to set the unary function name. The options for the object 30x2 are listed in Table 19.

The following unary functions can be used to process the input signals.

Table 19. Unary Functions

Function Number	Function Name	Description	Comment
0	Undefined	$f(x) = x$	Signal is not processed
1	! Logical Not	$f(x) = !x$	x is converted into 4-byte unsigned integer before function is applied
2	~ Bitwise Not	$f(x) = \sim x$	x is converted into 4-byte unsigned integer before function is applied
3	abs(x) Absolute	$f(x) = x, \text{ if } x \geq 0$ $f(x) = -x, \text{ if } x < 0$	

The object 300Ah **BF Binary Function** holds the parameters to set the binary function. The options for object 300Ah are shown in Table 20.

Table 20. Binary Functions

Function Number	Function Name	Description	Comment
0	Undefined	$F[x;y] = \text{Undefined}$	Output signal is undefined
1	+ Addition	$F[x;y] = x + y$	
2	- Subtraction	$F[x;y] = x - y$	
3	* Multiplication	$F[x;y] = x * y$	
4	/ Division	$F[x;y] = x / y$	Division by 0 gives 0
5	% Modulus	$F[x;y] = x \% y$	x and y are converted into 4-byte unsigned integers before function is applied
6	max(x,y) Maximum	$F[x;y] = x, \text{ if } x \geq y$ $F[x;y] = y, \text{ if } x < y$	
7	min(x,y) Minimum	$F[x;y] = x, \text{ if } x \leq y$ $F[x;y] = y, \text{ if } x > y$	
8	== Equal	$F[x;y] = 1, \text{ if } x = y$ $F[x;y] = 0, \text{ if } x \neq y$	
9	!= Not Equal	$F[x;y] = 1, \text{ if } x \neq y$ $F[x;y] = 0, \text{ if } x = y$	
10	> Great	$F[x;y] = 1, \text{ if } x > y$ $F[x;y] = 0, \text{ if } x \leq y$	
11	>= Great Equal	$F[x;y] = 1, \text{ if } x \geq y$ $F[x;y] = 0, \text{ if } x < y$	
12	< Less	$F[x;y] = 1, \text{ if } x < y$ $F[x;y] = 0, \text{ if } x \geq y$	
13	<= Less Equal	$F[x;y] = 1, \text{ if } x \leq y$ $F[x;y] = 0, \text{ if } x > y$	
14	Logical OR	$F[x;y] = x \vee y$	x and y are converted into 4-byte unsigned integers before function is applied
15	&& Logical AND	$F[x;y] = x \wedge y$	x and y are converted into 4-byte unsigned integers before function is applied

Function Number	Function Name	Description	Comment
16	Bitwise OR	$F[x;y] = x y$	x and y are converted into 4-byte unsigned integers before function is applied
17	& Bitwise AND	$F[x;y] = x \& y$	x and y are converted into 4-byte unsigned integers before function is applied
18	^ Bitwise XOR	$F[x;y] = x \wedge y$	x and y are converted into 4-byte unsigned integers before function is applied
19	<< Left Shift	$F[x;y] = x \ll y$	x and y are converted into 4-byte unsigned integers before function is applied
20	>> Right Shift	$F[x;y] = x \gg y$	x and y are converted into 4-byte unsigned integers before function is applied

The *Binary Function* has the following set of configuration parameters.

Table 21. Binary Function Block Configuration Parameters

Name	Default Value	Range	Description	Configuration object
Binary Function	0 - Undefined	See Binary Function table	$F[x;y]$ – Binary function	300Ah
Output Scale	1	Any value	A – Output Scale	300Bh
Output Offset	0	Any value	B – Output Offset	300Ch
Input #1 Signal Source	0 - Not Connected	Any signal output of any function block or "Not Connected". See Signal Source table.	X_1 – Input Signal #1	30x0h
Input #1 Signal Default	0 - No	0 - No, 1 - Yes	Defines whether the default signal value for X_1 is defined.	30x1h
Input #1 Signal Default Value	0	Any value	X_1 default value, if <i>Input #1 Signal Default</i> is Yes.	30x2h
Unary Function #1	0 - Undefined	See Unary Function table	$f_1(x)$ – Unary function #1	30x3h
Scale #1	1	Any value	a_1 – Scale #1	30x4h
Offset #1	0	Any value	b_1 – Offset #1	30x5h
Input #2 Signal Source	0 - Not Connected	Any signal output of any function block or "Not Connected". See Signal Source table.	X_2 – Input Signal #2	30x0h
Input #2 Signal Default	1 - Yes	0 - No, 1 - Yes	Defines whether the default signal value for X_2 is defined.	30x1h
Input #2 Signal Default Value	1	Any value	X_2 default value, if <i>Input #2 Signal Default</i> is Yes.	30x2h
Unary Function #2	0 - Undefined	See Unary Function table	$f_2(x)$ – Unary function #2	30x3h

Name	Default Value	Range	Description	Configuration object
Scale #2	1	Any value	a ₂ – Scale #2	30x4h
Offset #2	0	Any value	b ₂ – Offset #2	30x5h

Objects 30x0h...30x5h holds values for both inputs. To set a specific binary function, the 'x' in the object address should be replaced with values 1...Ah, where 1 will represent Binary Function 1, and Ah will represent Binary Function 10.

3.5 Miscellaneous Function Block

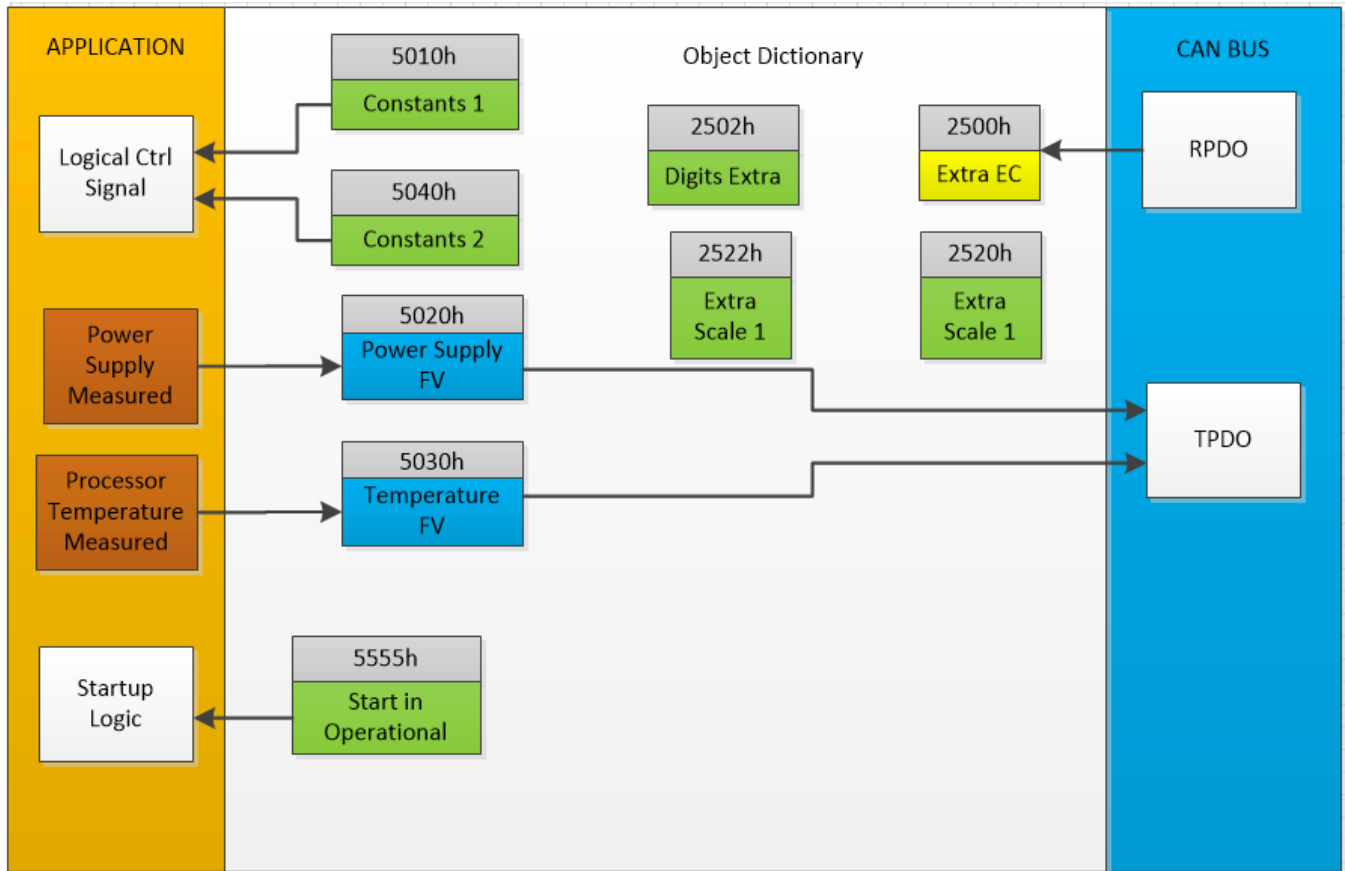

Figure 11 – Miscellaneous Objects

3.5.1 Extra RPDO Messages

Objects 2500h **Extra Control Received PV**, 2502h **EC Decimal Digits PV**, 2502h **EC Scaling 1 PV** and **EC Scaling 2 PV** allow for additional data received on a CANopen ® RPDO to be mapped independently to various function blocks as a control source. The scaling objects are provided to define the limits of the data when it is used by another function block, as shown in Figure 11.

3.5.2 Startup

The last object 5555h **Start in Operational** is provided as a ‘cheat’ when the unit is not intended to work with a CANopen network (i.e. a stand-alone control) or is working on a network comprised solely as slaves so the OPERATION command will never be received from a master. By default, this object is disabled (FALSE).

When using the AX100261 as a stand-alone controller where 5555h is set to TRUE, it is recommended to disable all TPDOs (set the Event Timer to zero) so that it does not run with a continuous CAN error when not connected to a bus.

3.5.3 Global Parameters

The *Global Parameters* objects give the user access to a set of global constants, unit supply voltage and the microcontroller internal temperature.

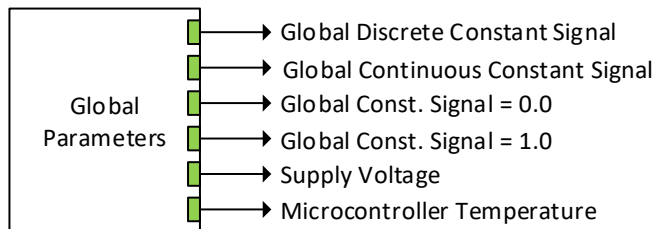

Figure 12. Global Parameters Function Block

Object 5010h **Constant Field Value** is provided to give the user the option for a fixed value that can be used by other function blocks. Sub-index 1 is fixed as FALSE (0) and sub-index 2 is always TRUE (1). There are 13 other sub-indexes provided for user selectable values.

The constants are read as 32-bit real (float) data, so no decimal digit object is provided. When setting up the constant, make sure to do it with the resolution of the object that will be compared with it.

The False/True constants are mappable, so the ECU is capable to use it as a control source for Binary Function and CAN Output.

The ECU also provides the “Supply Voltage” signal presenting the controller supply voltage in [V] and the “Microcontroller Temperature” signal presenting the internal microcontroller temperature in [°C]. Object 5040h **FD Temperature Field Value** holds the temperature measurements. Voltage level is stored in object 5041h **FD Voltage Field Value**.

Please note, that the “Supply Voltage” signal does not present the voltage on the controller power supply connector pins. It shows an internal voltage measured after the EMI filter, reverse polarity, and transient protection circuit. It is always less than the actual power supply voltage by approximately 0.4 V.

Additionally, object 5020h **Constant Field Value 2** holds the configurable constants. Parameters that stored in this object are listed in Table 22.

Table 22. Global Parameters Function Block Configuration Parameters

Name	Default Value	Range	Units	Description
Global Continuous Constant Signal	0	Any value	–	Signal value of the <i>Global Continuous Constant Signal</i> .
Global Discrete Constant Signal	0	0... 4294967295 (0xFFFFFFFF)	–	Signal value of the <i>Global Discrete Constant Signal</i> .

3.6 Ethernet

The *Ethernet* function block defines the Modbus TCP interface settings. It does not have signal inputs and outputs.

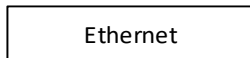

Figure 13. Ethernet Function Block

Configuration parameters of the *Ethernet* function block and respective objects are presented below.

Table 23. Ethernet Function Block Configuration Parameters

Name	Default Value	Range	Units	Description	Object description
MAC Address	Set at the factory	Any valid MAC address	–	Ethernet MAC Address. Set at the factory. Read-only parameter.	4000h ENET MAC Address
IP Address	192.168.0.34	Any IP address	–	The device IP address	4001h ENET IP Address
Subnet Mask	255.255.255.0	Any IP address	–	The device subnet mask	4002h ENET Subnet Mask
Gateway	192.168.0.1	Any IP address	–	The device default gateway	4003h ENET Gateway Address
Modbus Port	502	Any port value except the Discovery Port (35100)	–	The Modbus listening port	4004h ENET Modbus Port
Modbus Timeout	1000	1...10000	ms	The Modbus communication timeout. Not used in the current firmware.	4005h ENET Modbus Timeout

Any updates to the function block configuration parameters will require a manual reset of the controller to apply the new Ethernet settings.

4 Communication Objects (DS-301)

The communication objects supported by the AX032101 Controller are listed in the following table. A more detailed description of some of the objects is given in the following subchapters. Only those objects that have device-profile specific information are described. For more information on the other objects, refer to the generic CANopen protocol specification DS-301.

Index (hex)	Object	Object Type	Data Type	Access	PDO Mapping
1000	Device Type	VAR	UNSIGNED32	RO	No
1001	Error Register	VAR	UNSIGNED8	RO	No
1002	Manufacturer Status Register	VAR	UNSIGNED32	RO	No
1003	Pre-Defined Error Field	ARRAY	UNSIGNED32	RO	No
100C	Guard Time	VAR	UNSIGNED16	RW	No
100D	Life Time Factor	VAR	UNSIGNED8	RW	No
1010	Store Parameters	ARRAY	UNSIGNED32	RW	No
1011	Restore Default Parameters	ARRAY	UNSIGNED32	RW	No
1016	Consumer Heartbeat Time	ARRAY	UNSIGNED32	RW	No
1017	Producer Heartbeat Time	VAR	UNSIGNED16	RW	No
1018	Identity Object	RECORD		RO	No
1020	Verify Configuration	ARRAY	UNSIGNED32	RO	No
1029	Error Behavior	ARRAY	UNSIGNED8	RW	No
1400	RPDO1 Communication Parameter	RECORD		RW	No
1401	RPDO2 Communication Parameter	RECORD		RW	No
1402	RPDO3 Communication Parameter	RECORD		RW	No
1600	RPDO1 Mapping Parameter	RECORD		RO	No
1601	RPDO2 Mapping Parameter	RECORD		RO	No
1602	RPDO3 Mapping Parameter	RECORD		RO	No
1800	TPDO1 Communication Parameter	RECORD		RW	No
1801	TPDO2 Communication Parameter	RECORD		RW	No
1802	TPDO3 Communication Parameter	RECORD		RW	No
1803	TPDO4 Communication Parameter	RECORD		RW	No
1805	TPDO5 Communication Parameter	RECORD		RW	No
1A00	TPDO1 Mapping Parameter	RECORD		RW	No
1A01	TPDO2 Mapping Parameter	RECORD		RW	No
1A02	TPDO3 Mapping Parameter	RECORD		RW	No
1A03	TPDO4 Mapping Parameter	RECORD		RW	No
1A04	TPDO5 Mapping Parameter	RECORD		RW	No

4.1 1000h Device Type

Index	Subindex	Data Type	Access	PDO Mapping	Value Range	Default Value	Description
1000	0	UINT32	RO	No	0x194	0x194	DS-404

4.2 1001h Error Register

Index	Subindex	Data Type	Access	PDO Mapping	Value Range	Default Value	Description
1001	0	UINT8	RO	No	0, 1	0	Error register

4.3 1002h Manufacturer Status Object

Index	Subindex	Data Type	Access	PDO Mapping	Value Range	Default Value	Description
1002	0	UINT32	RO	No	UINT32	0	Manufacturer debug information

4.4 1003h Pre-Defined Error Field

Index	Subindex	Data Type	Access	PDO Mapping	Value Range	Default Value	Description	
1003	0	UINT8	RW	No	15	15	Number of subindexes / reset error codes	
	1	UINT32	RO			UINT32	0	EMCY error code #1
	2							EMCY error code #2
	3							EMCY error code #3
	4							EMCY error code #4
	5							EMCY error code #5

4.5 100Ch Guard Time

Index	Subindex	Data Type	Access	PDO Mapping	Value Range	Default Value	Description
100C	0	UINT16	RW	No	UINT16	0	The guard time in milliseconds. The access is RO, if it is not supported

4.6 100Dh Life Time Factor

Index	Subindex	Data Type	Access	PDO Mapping	Value Range	Default Value	Description
100D	0	UINT8	RW	No	UINT8	0	The life time factor multiplied with the guard time gives the life time for the node guarding protocol. It is 0 if not used.

4.7 1010h Store Parameters

Index	Subindex	Data Type	Access	PDO Mapping	Value Range	Default Value	Description
1010	0	UINT8	RO	No	4	4	Number of subindexes
	1	UINT32	RW		save	1	Write 0x65766173 ('e', 'v', 'a', 's') for storing ALL parameters
	2						Write 0x65766173 ('e', 'v', 'a', 's') for storing Communication parameters
	3						Write 0x65766173 ('e', 'v', 'a', 's') for storing Application parameters
	4						Write 0x65766173 ('e', 'v', 'a', 's') for storing Manufacturer parameters
	5						Write 0x65766173 ('e', 'v', 'a', 's') for storing Manufacturer parameters 2

4.8 1011h Restore Parameters

Index	Subindex	Data Type	Access	PDO Mapping	Value Range	Default Value	Description
1011	0	UINT8	RO	No	4	4	Number of subindexes
	1	UINT32	RW		load	1	Write 0x4616F6C ('d', 'a', 'o', 'l') for restoring ALL parameters
	2						Write 0x4616F6C ('d', 'a', 'o', 'l') for restoring Communication parameters
	3						Write 0x4616F6C ('d', 'a', 'o', 'l') for restoring Application parameters
	4						Write 0x4616F6C ('d', 'a', 'o', 'l') for restoring Manufacturer parameters
	5						Write 0x4616F6C ('d', 'a', 'o', 'l') for restoring Manufacturer parameters 2

4.9 1016h Consumer Heartbeat Time

Index	Subindex	Data Type	Access	PDO Mapping	Value Range	Default Value	Description	
1016	0	UINT8	RO	No	4	4	Number of subindexes	
	1	UINT32	RW			UINT32	0	Consumer heartbeat time
	2							bits 31-24: reserved
	3							bits 23-16: Node ID
	4							bits 15-0: heartbeat time in milliseconds

4.10 1017h Producer Heartbeat Time

Index	Subindex	Data Type	Access	PDO Mapping	Value Range	Default Value	Description
1017	0	UINT16	RW	No	10-65000	0	Producer heartbeat time in milliseconds

4.11 1018h Identity Object

Index	Subindex	Data Type	Access	PDO Mapping	Value Range	Default Value	Description	
1018	0	UINT8	RO	No	4	4	Number of subindexes	
	1	UINT32				UINT32	0x55	Vendor ID (Axiomatic Technologies)
	2						0xAA100261	Product Code
	3							Revision Number
	4							Serial Number

4.12 1020h Verify Configuration

Index	Subindex	Data Type	Access	PDO Mapping	Value Range	Default Value	Description	
1020	0	UINT8	RO	No	4	4	Number of subindexes	
	1	UINT32				UINT32		Configuration date: DD-MM-YYYY
	2							Configuration time: HH-MM

4.13 1029h Error Behavior

Index	Subindex	Data Type	Access	PDO Mapping	Value Range	Default Value	Description
1029	0	UINT8	RO	No	6	4	Number of subindexes
	1		RW		0-2	1 (no change)	State transition on Comm. fault
	2						State transition on DI fault
	3						State transition on AI fault
	4						State transition on DO fault
	5						State transition on AO fault
	6						State transition on other faults

4.14 1400h RPDO 1 Communication Parameters

Index	Subindex	Data Type	Access	PDO Mapping	Value Range	Default Value	Description
1400	0	UINT8	RO	No	5	5	Number of subindexes
	1	UINT32	RW		UINT32	0x4000027F	COB-ID
	2	UINT8			UINT8	0xFF	Transmission type
	3	UINT16			UINT16	0	Inhibit time
	4	UINT8			UINT8	0	Compatibility entry
	5	UINT16			UINT16	0	Event timer

4.15 1401h RPDO 2 Communication Parameters

Index	Subindex	Data Type	Access	PDO Mapping	Value Range	Default Value	Description
1401	0	UINT8	RO	No	5	5	Number of subindexes
	1	UINT32	RW		UINT32	0x4000037F	COB-ID
	2	UINT8			UINT8	0xFF	Transmission type
	3	UINT16			UINT16	0	Inhibit time
	4	UINT8			UINT8	0	Compatibility entry
	5	UINT16			UINT16	0	Event timer

4.16 1402h RPDO 3 Communication Parameters

Index	Subindex	Data Type	Access	PDO Mapping	Value Range	Default Value	Description
1402	0	UINT8	RO	No	5	5	Number of subindexes
	1	UINT32	RW		UINT32	0x4000047F	COB-ID
	2	UINT8			UINT8	0xFF	Transmission type
	3	UINT16			UINT16	0	Inhibit time
	4	UINT8			UINT8	0	Compatibility entry
	5	UINT16			UINT16	0	Event timer

4.17 1600h RPDO 1 Mapping Parameters

Index	Subindex	Data Type	Access	PDO Mapping	Value Range	Default Value	Description
1600	0	UINT8	RW	No	0-4	4	Not used by default
	1	UINT32			UINT32	0x25000110	EC Extra Received PV #1
	2					0x25000210	EC Extra Received PV #2
	3					0x25000310	EC Extra Received PV #3
	4					0x25000410	EC Extra Received PV #4

4.18 1601h RPDO 2 Mapping Parameters

Index	Subindex	Data Type	Access	PDO Mapping	Value Range	Default Value	Description
1601	0	UINT8	RW	No	0-4	4	Number of subindexes
	1	UINT32			UINT32	0x25000510	EC Extra Received PV #5
	2					0x25000610	EC Extra Received PV #6
	3					0x25000710	EC Extra Received PV #7
	4					0x25000810	EC Extra Received PV #8

4.19 1602h RPDO 3 Mapping Parameters

Index	Subindex	Data Type	Access	PDO Mapping	Value Range	Default Value	Description
1602	0	UINT8	RW	No	0-4	4	Number of subindexes
	1	UINT32			UINT32	0x25000910	EC Extra Received PV #9

	2					0x25000A10	EC Extra Received PV #10
	3					0x25000B10	EC Extra Received PV #11
	4					0x25000C10	EC Extra Received PV #12

4.20 1800h TPDO 1 Communication Parameters

Index	Subindex	Data Type	Access	PDO Mapping	Value Range	Default Value	Description
1800	0	UINT8	RO	No	5	5	Number of subindexes
	1	UINT32	RW		UINT32	0x400001FF	COB-ID
	2	UINT8			UINT8	0xFE	Transmission type
	3	UINT16			UINT16	0	Inhibit time
	4	UINT8			UINT8	0	Compatibility entry
	5	UINT16			UINT16	0xFA	Event timer

4.21 1801h TPDO 2 Communication Parameters

Index	Subindex	Data Type	Access	PDO Mapping	Value Range	Default Value	Description
1801	0	UINT8	RO	No	5	5	Number of subindexes
	1	UINT32	RW		UINT32	0x400002FF	COB-ID
	2	UINT8			UINT8	0xFE	Transmission type
	3	UINT16			UINT16	0	Inhibit time
	4	UINT8			UINT8	0	Compatibility entry
	5	UINT16			UINT16	0xFA	Event timer

4.22 1802h TPDO 3 Communication Parameters

Index	Subindex	Data Type	Access	PDO Mapping	Value Range	Default Value	Description
1802	0	UINT8	RO	No	5	5	Number of subindexes
	1	UINT32	RW		UINT32	0x400003FF	COB-ID
	2	UINT8			UINT8	0xFE	Transmission type
	3	UINT16			UINT16	0	Inhibit time
	4	UINT8			UINT8	0xFA	Compatibility entry

	5	UINT16			UINT16	0	Event timer
--	---	--------	--	--	--------	---	-------------

4.23 1803h TPDO 4 Communication Parameters

Index	Subindex	Data Type	Access	PDO Mapping	Value Range	Default Value	Description
1803	0	UINT8	RO	No	5	5	Number of subindexes
	1	UINT32	RW		UINT32	0xC00004FF	COB-ID
	2	UINT8			UINT8	0xFE	Transmission type
	3	UINT16			UINT16	0	Inhibit time
	4	UINT8			UINT8	0	Compatibility entry
	5	UINT16			UINT16	0xFA	Event timer

4.24 1804h TPDO 5 Communication Parameters

Index	Subindex	Data Type	Access	PDO Mapping	Value Range	Default Value	Description
1803	0	UINT8	RO	No	5	5	Number of subindexes
	1	UINT32	RW		UINT32	0xC00005FF	COB-ID
	2	UINT8			UINT8	0xFE	Transmission type
	3	UINT16			UINT16	0	Inhibit time
	4	UINT8			UINT8	0	Compatibility entry
	5	UINT16			UINT16	0	Event timer

4.25 1A00h TPDO 1 Mapping Parameters

Index	Subindex	Data Type	Access	PDO Mapping	Value Range	Default Value	Description
1A00	0	UINT8	RW	No	0-4	4	Number of subindexes
	1	UINT32			UINT32	0x71300110	AI Input PV #1
	2					0x71300210	AI Input PV #2
	3					0x71300310	AI Input PV #3
	4					0x71300410	AI Input PV #4

4.26 1A01h TPDO 2 Mapping Parameters

Index	Subindex	Data Type	Access	PDO Mapping	Value Range	Default Value	Description
1A01	0	UINT8	RW	No	0-4	4	Number of subindexes
	1	UINT32			UINT32	0x71300510	AI Input PV #5
	2					0x71300610	AI Input PV #6
	3					0x71300710	AI Input PV #7
	4					0x71300810	AI Input PV #8

4.27 1A02h TPDO 3 Mapping Parameters

Index	Subindex	Data Type	Access	PDO Mapping	Value Range	Default Value	Description
1A02	0	UINT8	RW	No	0-4	2	Number of subindexes
	1	UINT32			UINT32	0x71300910	AI Input PV #9
	2					0x71300A10	AI Input PV #10
	3					0	Not used by default
	4					0	Not used by default

4.28 1A03h TPDO 4 Mapping Parameters

Index	Subindex	Data Type	Access	PDO Mapping	Value Range	Default Value	Description
1A03	0	UINT8	RW	No	0-4	2	Number of subindexes
	1	UINT32			UINT32	0x60000108	DI Input 1-8
	2					0x60000208	DI Input 9-10
	3					0	Not used by default
	4					0	Not used by default

5 Application Objects (DS-404 Inputs)

Index (hex)	Object	Object Type	Data Type	Access	PDO Mapping
6000	DI Read State 8 Input Lines	VAR	UNSIGNED8	RO	Yes
6002	DI Polarity 8 Input Lines	VAR	UNSIGNED8	RW	No
7100	AI Input Field Value	ARRAY	INTEGER16	RO	Yes
6110	AI Sensor Type	ARRAY	UNSIGNED16	RW	No
6112	AI Operating Mode	ARRAY	UNSIGNED8	RW	No
7120	AI Input Scaling 1 FV	ARRAY	INTEGER16	RW	No
7121	AI Input Scaling 1 PV	ARRAY	INTEGER16	RW	No
7122	AI Input Scaling 2 FV	ARRAY	INTEGER16	RW	No
7123	AI Input Scaling 2 PV	ARRAY	INTEGER16	RW	No
7124	AI Input Offset	ARRAY	INTEGER16	RW	No
7130	AI Input Process Value	ARRAY	INTEGER16	RO	Yes
6132	AI Decimal Digits PV	ARRAY	UNSIGNED8	RW	No

5.1 6000h DI Read State 8 Input Lines

Index	Subindex	Data Type	Access	PDO Mapping	Value Range	Default Value	Description
6000	0	UINT8	RO	Yes	0...2	2	Number of subindexes
	1	UINT8	RM	Yes	0x0 ... 0xFF	0	Digital Input state bitmap, one bit per input. Covers inputs 1...8
	2	UINT8	RM	Yes	0x0 ... 0x03	0	Digital Input state bitmap, one bit per input. Covers inputs 9-10

5.2 6002h DI Polarity 8 Input Lines

Index	Subindex	Data Type	Access	PDO Mapping	Value Range	Default Value	Description
6002	0	UINT8	RW	No	0x0 ... 0x3F	2	Digital Input state polarity bitmap, one bit per input. Inputs 5 & 6 are gate driver's active low fault lines.
	1	UINT8	RW	No	0x0 ... 0xFF	0	Digital Input state polarity bitmap, one bit per input. Covers inputs 1...8
	2	UINT8	RW	No	0x0 ... 0x03	0	Digital Input state polarity bitmap, one bit per input. Covers inputs 9-10

5.3 7100h AI Input Field Value

Index	Subindex	Data Type	Access	PDO Mapping	Value Range	Default Value	Description
7100	0	UINT8	RO	Yes	10	10	Number of subindexes
	1	INT16	RM		INT16	0	Input #1 field value
	2						Input #2 field value
	3						Input #3 field value
	4						Input #4 field value
	5						Input #5 field value
	6						Input #6 field value
	7						Input #7 field value
	8						Input #8 field value
	9						Input #9 field value
	10						Input #10 field value

5.4 6110h AI Sensor Type

Index	Subindex	Data Type	Access	PDO Mapping	Value Range	Default Value	Description
6110	0	UINT8	RO	No	10	10	Number of subindexes
	1	UINT16	RW		40,50,60,10000	40	Input #1 sensor type
	2						Input #2 sensor type
	3						Input #3 sensor type
	4						Input #4 sensor type
	5						Input #5 sensor type
	6						Input #6 sensor type
	7						Input #7 sensor type
	8						Input #8 sensor type
	9						Input #9 sensor type
	10						Input #10 sensor type

1. Unipolar inputs has additional parameter – resistive input

5.5 6112h AI Operating Mode

Index	Subindex	Data Type	Access	PDO Mapping	Value Range	Default Value	Description
6112	0	UINT8	RO	No	10	10	Number of subindexes
	1	UINT16	RW		0, 1, 10, 20	1	Input #1 operating mode
	2						Input #2 operating mode
	3						Input #3 operating mode
	4						Input #4 operating mode
	5						Input #5 operating mode
	6						Input #6 operating mode
	7						Input #7 operating mode
	8						Input #8 operating mode
	9						Input #9 operating mode
	10						Input #10 operating mode

5.6 7120h AI Input Scaling 1 FV

Index	Subindex	Data Type	Access	PDO Mapping	Value Range	Default Value	Description
7120	0	UINT8	RO	No	10	10	Number of subindexes
	1	INT16	RW		INT16	0	Input #1 field value scaler 1
	2						Input #2 field value scaler 1
	3						Input #3 field value scaler 1
	4						Input #4 field value scaler 1
	5						Input #5 field value scaler 1
	6						Input #6 field value scaler 1
	7						Input #7 field value scaler 1
	8						Input #8 field value scaler 1
	9						Input #9 field value scaler 1
	10						Input #10 field value scaler 1

5.7 7121h AI Input Scaling 1 PV

Index	Subindex	Data Type	Access	PDO Mapping	Value Range	Default Value	Description
7121	0	UINT8	RO	No	10	10	Number of subindexes
	1	INT16	RW		INT16	0	Input #1 process value scaler 1
	2						Input #2 process value scaler 1
	3						Input #3 process value scaler 1
	4						Input #4 process value scaler 1
	5						Input #5 process value scaler 1
	6						Input #6 process value scaler 1
	7						Input #7 process value scaler 1
	8						Input #8 process value scaler 1
	9						Input #9 process value scaler 1
	10						Input #10 process value scaler 1

5.8 7122h AI Input Scaling 2 FV

Index	Subindex	Data Type	Access	PDO Mapping	Value Range	Default Value	Description
7122	0	UINT8	RO	No	10	10	Number of subindexes
	1	INT16	RW		INT16	0	Input #1 field value scaler 2
	2						Input #2 field value scaler 2
	3						Input #3 field value scaler 2
	4						Input #4 field value scaler 2
	5						Input #5 field value scaler 2
	6						Input #6 field value scaler 2
	7						Input #7 field value scaler 2
	8						Input #8 field value scaler 2
	9						Input #9 field value scaler 2
	10						Input #10 field value scaler 2

5.9 7123h AI Input Scaling 2 PV

Index	Subindex	Data Type	Access	PDO Mapping	Value Range	Default Value	Description
7123	0	UINT8	RO	No	10	10	Number of subindexes
	1	INT16	RW		INT16	0	Input #1 process value scaler 2
	2						Input #2 process value scaler 2
	3						Input #3 process value scaler 2
	4						Input #4 process value scaler 2
	5						Input #5 process value scaler 2
	6						Input #6 process value scaler 2
	7						Input #7 process value scaler 2
	8						Input #8 process value scaler 2
	9						Input #9 process value scaler 2
	10						Input #10 process value scaler 2

5.10 7124h AI Input Offset

Index	Subindex	Data Type	Access	PDO Mapping	Value Range	Default Value	Description
7124	0	UINT8	RO	No	10	10	Number of subindexes
	1	INT16	RW		INT16	0	Input #1 input offset 1
	2						Input #2 input offset 2
	3						Input #3 input offset 3
	4						Input #4 input offset 4
	5						Input #5 input offset 5
	6						Input #6 input offset 6
	7						Input #7 input offset 7
	8						Input #8 input offset 8
	9						Input #9 input offset 9
	10						Input #10 input offset 10

5.11 7130h AI Input Process Value

Index	Subindex	Data Type	Access	PDO Mapping	Value Range	Default Value	Description
7130	0	UINT8	RO	No	10	10	Number of subindexes
	1	INT16	RM	Yes	INT16	0	Input #1 process value
	2						Input #2 process value
	3						Input #3 process value
	4						Input #4 process value
	5						Input #5 process value
	6						Input #6 process value
	7						Input #7 process value
	8						Input #8 process value
	9						Input #9 process value
	10						Input #10 process value

5.12 6132h AI Decimal Digits PV

Index	Subindex	Data Type	Access	PDO Mapping	Value Range	Default Value	Description
6132	0	UINT8	RO	No	6	6	Number of subindexes
	1	INT16	RW		0-3	3	Input #1 PV decimal digits
	2				Input #2 PV decimal digits		
	3				Input #3 PV decimal digits		
	4				Input #4 PV decimal digits		
	5				Input #5 PV decimal digits		
	6				Input #6 PV decimal digits		
	7				Input #7 PV decimal digits		
	8				Input #8 PV decimal digits		
	9				Input #9 PV decimal digits		
	10				Input #10 PV decimal digits		

6 Manufacturer Objects

Index (hex)	Object	Object Type	Data Type	Access	PDO Mapping
2020	DI Pull Up Down Mode 1 Input Line	ARRAY	UNSIGNED8	RW	No
2030	DI Debounce Filter	ARRAY	UNSIGNED8	RW	No
2040	DI Debounce Time	ARRAY	UNSIGNED16	RW	No
2050	AI Frequency Averaging	ARRAY	UNSIGNED8	RW	No
2100	AI Input Range	ARRAY	UNSIGNED8	RW	No
2101	AI Analog LoZ Input	ARRAY	UNSIGNED8	RW	No
2102	AI Decimal Digits FV	ARRAY	UNSIGNED8	RW	No
2103	AI Analog Input Filter	ARRAY	UNSIGNED8	RW	No
3000	BF Binary Output FV	ARRAY	UNSIGNED8	RM	Yes
300A	BF Binary Output Function	ARRAY	UNSIGNED8	RW	No
300B	BF Binary Output Scale	ARRAY	FLOAT32	RW	No
300C	BF Binary Output Offset	ARRAY	FLOAT32	RW	No
3010	BF Signal Source 1	ARRAY	UNSIGNED8	RW	No
3020	BF Signal Source 2	ARRAY	UNSIGNED8	RW	No
3030	BF Signal Source 3	ARRAY	UNSIGNED8	RW	No
3040	BF Signal Source 4	ARRAY	UNSIGNED8	RW	No
3050	BF Signal Source 5	ARRAY	UNSIGNED8	RW	No
3060	BF Signal Source 6	ARRAY	UNSIGNED8	RW	No
3070	BF Signal Source 7	ARRAY	UNSIGNED8	RW	No
3080	BF Signal Source 8	ARRAY	UNSIGNED8	RW	No
3090	BF Signal Source 9	ARRAY	UNSIGNED8	RW	No
30A0	BF Signal Source 10	ARRAY	UNSIGNED8	RW	No
3011	BF Is Default Signal 1	ARRAY	UNSIGNED8	RW	No
3021	BF Is Default Signal 2	ARRAY	UNSIGNED8	RW	No
3031	BF Is Default Signal 3	ARRAY	UNSIGNED8	RW	No
3041	BF Is Default Signal 4	ARRAY	UNSIGNED8	RW	No
3051	BF Is Default Signal 5	ARRAY	UNSIGNED8	RW	No
3061	BF Is Default Signal 6	ARRAY	UNSIGNED8	RW	No
3071	BF Is Default Signal 7	ARRAY	UNSIGNED8	RW	No
3081	BF Is Default Signal 8	ARRAY	UNSIGNED8	RW	No
3091	BF Is Default Signal 9	ARRAY	UNSIGNED8	RW	No
30A1	BF Is Default Signal 10	ARRAY	UNSIGNED8	RW	No
3012	BF Default Signal 1	ARRAY	FLOAT32	RW	No
3022	BF Default Signal 2	ARRAY	FLOAT32	RW	No
3032	BF Default Signal 3	ARRAY	FLOAT32	RW	No
3042	BF Default Signal 4	ARRAY	FLOAT32	RW	No
3052	BF Default Signal 5	ARRAY	FLOAT32	RW	No
3062	BF Default Signal 6	ARRAY	FLOAT32	RW	No
3072	BF Default Signal 7	ARRAY	FLOAT32	RW	No
3082	BF Default Signal 8	ARRAY	FLOAT32	RW	No
3092	BF Default Signal 9	ARRAY	FLOAT32	RW	No
30A2	BF Default Signal 10	ARRAY	FLOAT32	RW	No

3013	BF Unary Function Name 1	ARRAY	UNSIGNED8	RW	No
3023	BF Unary Function Name 2	ARRAY	UNSIGNED8	RW	No
3033	BF Unary Function Name 3	ARRAY	UNSIGNED8	RW	No
3043	BF Unary Function Name 4	ARRAY	UNSIGNED8	RW	No
3053	BF Unary Function Name 5	ARRAY	UNSIGNED8	RW	No
3063	BF Unary Function Name 6	ARRAY	UNSIGNED8	RW	No
3073	BF Unary Function Name 7	ARRAY	UNSIGNED8	RW	No
3083	BF Unary Function Name 8	ARRAY	UNSIGNED8	RW	No
3093	BF Unary Function Name 9	ARRAY	UNSIGNED8	RW	No
30A3	BF Unary Function Name 10	ARRAY	UNSIGNED8	RW	No
3014	BF Unary Input Scale 1	ARRAY	FLOAT32	RW	No
3024	BF Unary Input Scale 2	ARRAY	FLOAT32	RW	No
3034	BF Unary Input Scale 3	ARRAY	FLOAT32	RW	No
3044	BF Unary Input Scale 4	ARRAY	FLOAT32	RW	No
3054	BF Unary Input Scale 5	ARRAY	FLOAT32	RW	No
3064	BF Unary Input Scale 6	ARRAY	FLOAT32	RW	No
3074	BF Unary Input Scale 7	ARRAY	FLOAT32	RW	No
3084	BF Unary Input Scale 8	ARRAY	FLOAT32	RW	No
3094	BF Unary Input Scale 9	ARRAY	FLOAT32	RW	No
30A4	BF Unary Input Scale 10	ARRAY	FLOAT32	RW	No
3015	BF Unary Input Offset 1	ARRAY	FLOAT32	RW	No
3025	BF Unary Input Offset 2	ARRAY	FLOAT32	RW	No
3035	BF Unary Input Offset 3	ARRAY	FLOAT32	RW	No
3045	BF Unary Input Offset 4	ARRAY	FLOAT32	RW	No
3055	BF Unary Input Offset 5	ARRAY	FLOAT32	RW	No
3065	BF Unary Input Offset 6	ARRAY	FLOAT32	RW	No
3075	BF Unary Input Offset 7	ARRAY	FLOAT32	RW	No
3085	BF Unary Input Offset 8	ARRAY	FLOAT32	RW	No
3095	BF Unary Input Offset 9	ARRAY	FLOAT32	RW	No
30A5	BF Unary Input Offset 10	ARRAY	FLOAT32	RW	No
2500	EC Extra Received Process Value	ARRAY	INTEGER16	RM	Yes
2502	EC Decimal Digits PV	ARRAY	UNSIGNED8	RW	No
2520	EC Scaling 1 PV	ARRAY	INTEGER16	RW	No
2522	EC Scaling 2 PV	ARRAY	INTEGER16	RW	No
4000	ENET MAC Address	ARRAY	UNSIGNED8	RW	No
4001	ENET IP Address	ARRAY	UNSIGNED8	RW	No
4002	ENET Subnet Mask	ARRAY	UNSIGNED8	RW	No
4003	ENET Gateway Address	ARRAY	UNSIGNED8	RW	No
4004	ENET Modbus Port	ARRAY	UNSIGNED16	RW	No
4005	ENET Modbus Timeout	ARRAY	UNSIGNED16	RW	No
5010	Constant Field Value	ARRAY	FLOAT32	RW	No
5020	Power Supply FV	VAR	FLOAT32	RO	Yes
5030	CPU Temperature FV	VAR	FLOAT32	RO	Yes
5040	Constant Field Value 2	ARRAY	UNSIGNED16	RWM	Yes
5041	Fault Detection Set Threshold	ARRAY	UNSIGNED16	RW	No
5500	SPP Command	ARRAY	UNSIGNED32	RWP	No
5510	SPP Response	ARRAY	UNSIGNED32	ROP	No

5550	Enable Auto Updates	VAR	BOOLEAN	RWP	No
5555	Start in Operational Mode	VAR	BOOLEAN	RWP	No
55AA	Start Bootloader	VAR	UNSIGNED8	RWP	No
5B50	Change Baud Rate	VAR	UNSIGNED8	RWP	No
5B51	Change Node ID	VAR	UNSIGNED8	RWP	No

6.1 2020h DI Pull Up Down Mode 1 Input Line

Index	Subindex	Data Type	Access	PDO Mapping	Value Range	Default Value	Description
2020	0	UINT8	RO	No	10	10	Number of subindexes
	1		RW		0-2	0	Input #1 pull up down mode
	2		Input #2 pull up down mode				
	3		Input #3 pull up down mode				
	4		Input #4 pull up down mode				
	5		Input #5 pull up down mode				
	6		Input #6 pull up down mode				
	7		Input #7 pull up down mode				
	8		Input #8 pull up down mode				
	9		Input #9 pull up down mode				
	10		Input #10 pull up down mode				

6.2 2030h DI Debounce Filter

Index	Subindex	Data Type	Access	PDO Mapping	Value Range	Default Value	Description
2030	0	UINT8	RO	No	10	10	Number of subindexes
	1		RW		0-3	0	Input #1 debounce filter
	2		Input #2 debounce filter				
	3		Input #3 debounce filter				
	4		Input #4 debounce filter				
	5		Input #5 debounce filter				
	6		Input #6 debounce filter				
	7		Input #7 debounce filter				
	8		Input #8 debounce filter				
	9		Input #9 debounce filter				
	10		Input #10 debounce filter				

6.3 2040h DI Debounce Time

Index	Subindex	Data Type	Access	PDO Mapping	Value Range	Default Value	Description
2040	0	UINT8	RO	No	10	10	Number of subindexes
	1	UINT16	RW		0...1000	0	Input #1 debounce time
	2				Input #2 debounce time		
	3				Input #3 debounce time		
	4				Input #4 debounce time		
	5				Input #5 debounce time		
	6				Input #6 debounce time		
	7				Input #7 debounce time		
	8				Input #8 debounce time		
	9				Input #9 debounce time		
	10				Input #10 debounce time		

6.4 2050h AI Frequency Averaging

Index	Subindex	Data Type	Access	PDO Mapping	Value Range	Default Value	Description
2030	0	UINT8	RO	No	10	10	Number of subindexes
	1		RW		0-3	0	Input #1 frequency averaging
	2				Input #2 frequency averaging		
	3				Input #3 frequency averaging		
	4				Input #4 frequency averaging		
	5				Input #5 frequency averaging		
	6				Input #6 frequency averaging		
	7				Input #7 frequency averaging		
	8				Input #8 frequency averaging		
	9				Input #9 frequency averaging		
	10				Input #10 frequency averaging		

6.5 2100h AI Input Range

Index	Subindex	Data Type	Access	PDO Mapping	Value Range	Default Value	Description
2100	0	UINT8	RO	No	10	10	Number of subindexes
	1		RW		Input type dependent	0	Input #1 range selection
	2		Input #2 range selection				
	3		Input #3 range selection				
	4		Input #4 range selection				
	5		Input #5 range selection				
	6		Input #6 range selection				
	7		Input #7 range selection				
	8		Input #8 range selection				
	9		Input #9 range selection				
	10		Input #10 range selection				

6.6 2101h AI Analog LoZ Input

Index	Subindex	Data Type	Access	PDO Mapping	Value Range	Default Value	Description
2101	0	UINT8	RO	No	10	10	Number of subindexes
	1		RW		0...1	0	Input #1 LoZ input
	2		Input #2 LoZ input				
	3		Input #3 LoZ input				
	4		Input #4 LoZ input				
	5		Input #5 LoZ input				
	6		Input #6 LoZ input				
	7		Input #7 LoZ input				
	8		Input #8 LoZ input				
	9		Input #9 LoZ input				
	10		Input #10 LoZ input				

6.7 2102h AI Decimal Digits FV

Index	Subindex	Data Type	Access	PDO Mapping	Value Range	Default Value	Description
2102	0	UINT8	RO	No	10	10	Number of subindexes
	1		RW		0-4	3	Input #1 decimal digits FV
	2		Input #2 decimal digits FV				
	3		Input #3 decimal digits FV				
	4		Input #4 decimal digits FV				
	5		Input #5 decimal digits FV				
	6		Input #6 decimal digits FV				
	7		Input #7 decimal digits FV				
	8		Input #8 decimal digits FV				
	9		Input #9 decimal digits FV				
	10		Input #10 decimal digits FV				

6.8 2103h AI Analog Input Filter

Index	Subindex	Data Type	Access	PDO Mapping	Value Range	Default Value	Description
2103	0	UINT8	RO	No	10	10	Number of subindexes
	1		RW		0-3	0	Input #1 analog input filter
	2		Input #2 analog input filter				
	3		Input #3 analog input filter				
	4		Input #4 analog input filter				
	5		Input #5 analog input filter				
	6		Input #6 analog input filter				
	7		Input #7 analog input filter				
	8		Input #8 analog input filter				
	9		Input #9 analog input filter				
	10		Input #10 analog input filter				

6.9 3000h BF Binary Output FV

Index	Subindex	Data Type	Access	PDO Mapping	Value Range	Default Value	Description
3000	0	UINT8	RO	No	10	10	Number of subindexes
	1	INT16	RO				Binary input #1 binary output FV
	2						Binary input #2 binary output FV
	3						Binary input #3 binary output FV
	4						Binary input #4 binary output FV
	5						Binary input #5 binary output FV
	6						Binary input #6 binary output FV
	7						Binary input #7 binary output FV
	8						Binary input #8 binary output FV
	9						Binary input #9 binary output FV
	10						Binary input #10 binary output FV

6.10 300Ah BF Output Function

Index	Subindex	Data Type	Access	PDO Mapping	Value Range	Default Value	Description		
300A	0	UINT8	RO	No	10	10	Number of subindexes		
	1		RW				0-20	0	Binary input #1 output function
	2		Binary input #2 output function						
	3		Binary input #3 output function						
	4		Binary input #4 output function						
	5		Binary input #5 output function						
	6		Binary input #6 output function						
	7		Binary input #7 output function						
	8		Binary input #8 output function						
	9		Binary input #9 output function						
	10		Binary input #10 output function						

6.11 300Bh BF Output Scale

Index	Subindex	Data Type	Access	PDO Mapping	Value Range	Default Value	Description
300B	0	UINT8	RO	No	10	10	Number of subindexes
	1	FLOAT32	RW		FLOAT32	0x3f800000	Binary input #1 output scale
	2						Binary input #2 output scale
	3						Binary input #3 output scale
	4						Binary input #4 output scale
	5						Binary input #5 output scale
	6						Binary input #6 output scale
	7						Binary input #7 output scale
	8						Binary input #8 output scale
	9						Binary input #9 output scale
	10						Binary input #10 output scale

6.12 300Ch BF Output Offset

Index	Subindex	Data Type	Access	PDO Mapping	Value Range	Default Value	Description
300C	0	UINT8	RO	No	10	10	Number of subindexes
	1	FLOAT32	RW		INT32	0	Binary input #1 output offset
	2						Binary input #2 output offset
	3						Binary input #3 output offset
	4						Binary input #4 output offset
	5						Binary input #5 output offset
	6						Binary input #6 output offset
	7						Binary input #7 output offset
	8						Binary input #8 output offset
	9						Binary input #9 output offset
	10						Binary input #10 output offset

6.13 30x0h BF Signal Source¹

Index	Subindex	Data Type	Access	PDO Mapping	Value Range	Default Value	Description
30x0	0	UINT8	RO	No	10	10	Number of subindexes
	1		RW		0...29	0	Binary input #x output offset 1
	2						Binary input #x output offset 2

1. x is the number from 1 to Ah that represents a couple of inputs

6.14 30x1h BF Is Default Signal¹

Index	Subindex	Data Type	Access	PDO Mapping	Value Range	Default Value	Description
30x1	0	UINT8	RO	No	10	10	Number of subindexes
	1		RW		0...1	0	Binary input #x is default signal 1
	2						Binary input #x is default signal 2

1. x is the number from 1 to Ah that represents a couple of inputs

6.15 30x2h BF Default Signal Value¹

Index	Subindex	Data Type	Access	PDO Mapping	Value Range	Default Value	Description
30x2	0	UINT8	RO	No	10	10	Number of subindexes
	1		RW		0...4,294,967,295	0	Binary input #x default signal value 1
	2						Binary input #x default signal value 2

1. x is the number from 1 to Ah that represents a couple of inputs

6.16 30x3h BF Unary Function Name¹

Index	Subindex	Data Type	Access	PDO Mapping	Value Range	Default Value	Description
30x3	0	UINT8	RO	No	10	10	Number of subindexes
	1		RW		0...3	0	Binary input #x unary function name 1
	2						Binary input #x unary function name 2

1. x is the number from 1 to Ah that represents a couple of inputs

6.17 30x4h BF Unary Input Scale¹

Index	Subindex	Data Type	Access	PDO Mapping	Value Range	Default Value	Description
30x4	0	UINT8	RO	No	10	10	Number of subindexes
	1	FLOAT32	RW		INT32	1.0	Binary input #x unary input scale 1
	2						Binary input #x unary input scale 2

1. x is the number from 1 to Ah that represents a couple of inputs

6.18 30x5h BF Unary Function Offset¹

Index	Subindex	Data Type	Access	PDO Mapping	Value Range	Default Value	Description
30x5	0	UINT8	RO	No	10	10	Number of subindexes
	1	FLOAT32	RW		INT32	0	Binary input #x unary function offset 1
	2						Binary input #x unary function offset 2

1. x is the number from 1 to Ah that represents a couple of inputs

6.19 4000h ENET MAC Address

Index	Subindex	Data Type	Access	PDO Mapping	Value Range	Default Value	Description
4000	0	UINT8	RO	No	6	6	Number of subindexes
	1	UINT8	RO		UINT8	0	Ethernet MAC address 1
	2						Ethernet MAC address 2
	3						Ethernet MAC address 3
	4						Ethernet MAC address 4
	5						Ethernet MAC address 5
	6						Ethernet MAC address 6

6.20 4001h ENET IP Address

Index	Subindex	Data Type	Access	PDO Mapping	Value Range	Default Value	Description
4001	0	UINT8	RO	No	UINT8	4	Number of subindexes
	1		RW			192	Ethernet IP address 1
	2					168	Ethernet IP address 2
	3					0	Ethernet IP address 3

	4					34	Ethernet IP address 4
--	---	--	--	--	--	----	-----------------------

6.21 4002h ENET Subnet Mask

Index	Subindex	Data Type	Access	PDO Mapping	Value Range	Default Value	Description
4002	0	UINT8	RO	No	4	4	Number of subindexes
	1		RW		UINT8	255	Ethernet subnet mask 1
	2					255	Ethernet subnet mask 2
	3					255	Ethernet subnet mask 3
	4					0	Ethernet subnet mask 4

6.22 4003h ENET Default Gateway

Index	Subindex	Data Type	Access	PDO Mapping	Value Range	Default Value	Description
4003	0	UINT8	RO	No	4	4	Number of subindexes
	1		RW		UINT8	192	Ethernet default gateway 1
	2					168	Ethernet default gateway 2
	3					0	Ethernet default gateway 3
	4					1	Ethernet default gateway 4

6.23 4005h ENET Modbus Port

Index	Subindex	Data Type	Access	PDO Mapping	Value Range	Default Value	Description
4004	0	UINT8	RO	No	1	1	Number of subindexes
	1	UINT16	RW		UINT16, except 35100	512	Ethernet modbus port

6.24 4005h ENET Modbus Timeout

Index	Subindex	Data Type	Access	PDO Mapping	Value Range	Default Value	Description
4005	0	UINT8	RO	No	1	1	Number of subindexes
	1	UINT16	RW		1...10000	1000	Ethernet modbus timeout

6.25 2500h EC Extra Received PV

Index	Subindex	Data Type	Access	PDO Mapping	Value Range	Default Value	Description	
2500	0	UINT8	RO	Yes	12	12	Number of subindexes	
	1	INT16	RW			INT16	0	Extra received PV 1
	2							Extra received PV 2
	3							Extra received PV 3
	4							Extra received PV 4
	5							Extra received PV 5
	6							Extra received PV 6
	7							Extra received PV 7
	8							Extra received PV 8
	9							Extra received PV 9
	10							Extra received PV 10
	11							Extra received PV 11
	12							Extra received PV 12

6.26 2502h EC Decimal Digits PV

Index	Subindex	Data Type	Access	PDO Mapping	Value Range	Default Value	Description	
2502	0	UINT8	RO	No	12	12	Number of subindexes	
	1		RW			0-3	0	Extra received PV 1 decimal digits
	2							Extra received PV 2 decimal digits
	3							Extra received PV 3 decimal digits
	4							Extra received PV 4 decimal digits
	5							Extra received PV 5 decimal digits
	6							Extra received PV 6 decimal digits
	7							Extra received PV 7 decimal digits
	8							Extra received PV 8 decimal digits
	9							Extra received PV 9 decimal digits
	10							Extra received PV 10 decimal digits
	11							Extra received PV 11 decimal digits
	12							Extra received PV 12 decimal digits

6.27 2520h EC Scaling 1 PV

Index	Subindex	Data Type	Access	PDO Mapping	Value Range	Default Value	Description
2502	0	UINT8	RO	No	12	12	Number of subindexes
	1	INT16	RW		INT16	0	EC 1 process value scaler 1
	2						EC 2 process value scaler 1
	3						EC 3 process value scaler 1
	4						EC 4 process value scaler 1
	5						EC 5 process value scaler 1
	6						EC 6 process value scaler 1
	7						EC 7 process value scaler 1
	8						EC 8 process value scaler 1
	9						EC 9 process value scaler 1
	10						EC 10 process value scaler 1
	11						EC 11 process value scaler 1
	12						EC 12 process value scaler 1

6.28 2522h EC Scaling 2 PV

Index	Subindex	Data Type	Access	PDO Mapping	Value Range	Default Value	Description
2522	0	UINT8	RO	No	12	12	Number of subindexes
	1	INT16	RW		INT16	0	EC 1 process value scaler 2
	2						EC 2 process value scaler 2
	3						EC 3 process value scaler 2
	4						EC 4 process value scaler 2
	5						EC 5 process value scaler 2
	6						EC 6 process value scaler 2
	7						EC 7 process value scaler 2
	8						EC 8 process value scaler 2
	9						EC 9 process value scaler 2
	10						EC 10 process value scaler 2
	11						EC 11 process value scaler 2
	12						EC 12 process value scaler 2

6.29 5010h Constant Field Value 1

Index	Subindex	Data Type	Access	PDO Mapping	Value Range	Default Value	Description
5010	0	UINT8	RO	Yes	2	2	Number of subindexes
	1	FLOAT32	RW		FLOAT32	0.0	Non modifiable constant values to be used in custom control application.
	2					1.0	

6.30 5020h Power Supply FV

Index	Subindex	Data Type	Access	PDO Mapping	Value Range	Default Value	Description
5020	0	FLOAT32	RO	Yes	FLOAT32	0	Measured power supply voltage

6.31 5030h CPU Temperature FV

Index	Subindex	Data Type	Access	PDO Mapping	Value Range	Default Value	Description
5030	0	FLOAT32	RO	Yes	FLOAT32	0	Measured CPU internal temperature

6.32 5040h Constant Field Value 2

Index	Subindex	Data Type	Access	PDO Mapping	Value Range	Default Value	Description
5040	0	UINT8	RO	Yes	2	2	Number of subindexes
	1	FLOAT32	RW		FLOAT32	0.0	User modifiable constant values to be used in custom control application.
	2						

6.33 5500h SPP Command

Index	Subindex	Data Type	Access	PDO Mapping	Value Range	Default Value	Description
5500	0	UINT8	RO	No	3	3	Number of subindexes
	1	UINT32	RW		UINT32	0	Node ID, data length, function ID, command id
	2					Byte3, byte2, byte1, byte0	

	3						
--	---	--	--	--	--	--	--

6.34 5510h SPP Response

Index	Subindex	Data Type	Access	PDO Mapping	Value Range	Default Value	Description	
5510	0	UINT8	RO	No	3	3	Number of subindexes	
	1	UINT32	RO			UINT32	0	
	2							
	3							

6.35 5550h Enable Auto Update

Index	Subindex	Data Type	Access	PDO Mapping	Value Range	Default Value	Description
5550	0	UINT8	RW	No	0-1	0	Enable/disable auto-update feature

6.36 5555h Start In Operational Mode

Index	Subindex	Data Type	Access	PDO Mapping	Value Range	Default Value	Description
5555	0	UINT8	RW	No	0-3	0	0 – No action, wait NMT commands 1 – Start directly in operational mode 2 – Start in operational mode and send NMT for starting also other devices 3 – Start in operational mode and set PDS FSA to Enabled Mode.

6.37 55AAh Start Bootloader

Index	Subindex	Data Type	Access	PDO Mapping	Value Range	Default Value	Description
55AA	0	UINT8	RW	No	0-1	0	Starts the bootloader if the value is 1

6.38 5B50h Change Baud Rate

Index	Subindex	Data Type	Access	PDO Mapping	Value Range	Default Value	Description

5B50	0	UINT8	RW	No	0-8, except 5	4	125kBps by default. 5 is reserved for future use
------	---	-------	----	----	---------------	---	--

6.39 5B51h Change Node ID

Index	Subindex	Data Type	Access	PDO Mapping	Value Range	Default Value	Description
5B51	0	UINT8	RW	No	0-127	127	Change the node ID

7 CONTROLLER CONFIGURATION

The controller can be configured in two independent ways: through the Modbus or CAN interface.

7.1 Modbus Configuration

The controller can be configured through the Modbus TCP interface using any third-party software tools.

The configuration parameters are grouped by the function blocks, see the MODBUS ADDRESS MAP section.

The controller checks configuration parameters for validity before accepting them and writing in a non-volatile memory. If a configuration parameter is invalid, the Modbus writing function will succeed, but the configuration parameter will not be written.

The controller will reset all relevant function blocks after each change of the configuration parameters. The exception is the *Ethernet* function block that maintains the Ethernet connection. The user will need to perform a manual reset by cycling the controller power to start using the new Ethernet settings.

Any changes in CAN function blocks through Modbus will restart CAN communication of the controller.

7.2 CANopen Configuration

The controller can be configured through the CANopen standard using any third-party software tools.

The configuration of each parameter conducts via changing the value in the respective object. All available objects (communication, application, and manufacturer specific) are described in Sections 4,5, and 6. Additional information can be found in Section 3 as well.

Note: In this user manual it is considered that the customer obtains the knowledge about CANopen standards. Additional information is available in CiA standards 301 and 404.

8 TECHNICAL SPECIFICATIONS

Stated at 25°C unless otherwise specified.

8.1 Power Supply

Table 24. Power Supply

Parameter	Value	Remarks
Supply Voltage	8...36 VDC	12V, 24V – nominal.
Supply Current	50 mA 100 mA	Typical at 24V. Typical at 12V.
Protection	Reverse polarity, Transients	

8.2 Bipolar Inputs

Table 25. Bipolar Inputs

Parameter	Value							
Analog Input Modes	Voltage, Current							
Voltage Input	Input Range	Input Impedance	Resolution	Accuracy				
	0...5V	1 MOhm ¹	<1.5mV	TBD				
	0...10V		<3 mV	TBD				
	-5...5V		<3 mV	TBD				
	-10...10V		<6 mV	TBD				
¹ 10kOhm LoZ option is available.								
Current Input	Input Range	Input Impedance	Resolution	Accuracy				
	0...20mA	124Ohm	<12uA	TBD				
	4...20mA							
Analog Update Rate	1.67ms minimum ¹ ¹ Depends on the analog filter settings							
Digital Input Modes	Discrete Voltage Level, Frequency, PWM Duty Cycle							
Input Polarity	Active High, Active Low							
Input Impedance	1MOhm – High Z, 10kOhm pull down, 10kOhm pull-up to +14V							
Input Level	5V CMOS Compatible. A direct connection to the power supply is acceptable.							
Discrete Voltage Level Input	1ms sampling rate. Configurable debouncing							
Frequency Input	Input Number	Counter Resolution	Frequency Range	Resolution ^{1,2}	Accuracy			
	Bipolar Input #1	32-bit	1Hz...10kHz	<0.0000012...0.012%	<0.01%			
			Bipolar Input #2			16-bit	100Hz...10kHz	<0.0017...0.17%
							10Hz...1kHz	
1Hz...100Hz								
PWM Duty Cycle Input	Input Number	Counter Resolution	Frequency Range	Resolution ^{1,2}	Accuracy			
	Bipolar Input #1	32-bit	1Hz...10kHz	<0.0000012...0.012%	TBD			
			Bipolar Input #2			16-bit	100Hz...10kHz	TBD
							10Hz...1kHz	
1Hz...100Hz								

Parameter	Value
	0...100% Duty Cycle Range. DC is included.
Protection	+/-36V maximum. Forward and reverse polarity protection

¹ The relative resolution value is linearly proportional to the signal frequency: 0.0000012% at 100Hz and 0.012% at 10kHz for the 32-bit counter.

² Resolution can be affected by the debouncing filter settings.

Notes:

CANopen® is a registered community trademark of CAN in Automation e.V.

8.3 Universal Inputs

Table 26. Universal Inputs

Parameter	Value				
Analog Input Modes	Voltage, Current, Resistance				
Voltage Input	Input Range	Input Impedance	Resolution	Accuracy	
	0...5V	>1M Ω (High Z) ¹	<1.5mV	TBD	
	0...10V	204k Ω ¹	<3 mV	TBD	
	¹ 10k Ω LoZ option is available.				
Current Input	Input Range	Input Impedance	Resolution	Accuracy	
	0...20mA	249 Ω	<12 μ A	TBD	
	4...20mA				
Resistance Input	Input Range	Resolution	Accuracy		
	Auto Range 10...250k Ω ^{1,2}	–	–		
	0...250 Ω ²	<0.15 Ω	TBD		
	0...2.5k Ω	<1.5 Ω	TBD		
	0...25k Ω	<15 Ω	TBD		
	0...250k Ω	<150 Ω	TBD		
¹ Resolution and accuracy depend on the automatically selected Input Range. ² Resistance <10 Ω is measured as 0.					
Analog Update Rate	1.67ms minimum ¹ . ¹ Depends on the analog filter settings. In resistive mode also depends on the number of resistive inputs.				
Digital Input Modes	Discrete Voltage Level, Frequency, PWM Duty Cycle				
Input Polarity	Active High, Active Low				
Input Impedance	>1M Ω – High Z, 10k Ω pull down, 10k Ω pull-up to +14V				
Input Level	5V CMOS Compatible. A direct connection to the power supply is acceptable.				
Discrete Voltage Level Input	1ms sampling rate. Configurable debouncing				
Frequency Input	Input Number	Counter Resolution	Frequency Range	Resolution ^{1,2}	Accuracy
	Universal Input #1...8	16-bit	100Hz...10kHz	<0.0017...0.17%	<0.01%
			10Hz...1kHz		
			1Hz...100Hz		

Parameter	Value				
PWM Duty Cycle Input	Input Number	Counter Resolution	Frequency Range	Resolution ^{1,2}	Accuracy
	Universal Input #1...8	16-bit	100Hz...10kHz	<0.0017...0.17%	TBD
			10Hz...1kHz		TBD
			1Hz...100Hz		TBD
0...100% Duty Cycle Range. DC is included.					
Protection	+36V maximum. Forward voltage only. No reverse polarity protection				

¹ The relative resolution value is linearly proportional to the signal frequency: 0.0017% at 100Hz and 0.17% at 10kHz for the 16-bit counter.

² Resolution can be affected by the debouncing filter settings.

8.4 Voltage Reference Outputs

Table 27. Voltage Reference Outputs

Parameter	Value	Remarks
Number of Outputs	2	
Output Voltage	+5V	
Voltage tolerance	1%	At 1mA
Supply Current	100mA	Nominal
Protection	Short circuit	Connection to the power supply is prohibited.

8.5 Ethernet Interface

Parameter	Value	Remarks
Number of Ports	1	Reading inputs, configuring the device.
Port Type	10BASE-T, 100BASE-TX	10 Mbit/s and 100Mbit/s Auto-configuration and full-duplex supported
MDIX	Auto-MDIX	Auto-crossover to eliminate cabling mismatch
LED Indicators	Speed/Link (Activity)	Yellow/Green
Protocols	Ethernet IEEE 802.3, IP, ICMP, ARP, UDP, TCP, Modbus TCP, Proprietary Discovery Protocol	Axiomatic Proprietary Discovery Protocol on port 35100
Modbus TCP/IP	Server mode (slave device). Supported Function codes:	
	2, 4	Reading Bipolar/Universal Inputs
	3, 6, 16, 23	Reading/Changing configuration parameters
	43/14	Reading controller ID, S/N on a private object 0x80
		Up to 8 simultaneous client connections

8.6 CAN Interface

Table 28. CAN Parameters

Parameter	Value	Remarks
Number of Ports	1	Reading inputs, configuring the device, updating firmware
LED Indicator	Error/Link (Activity)	Red/Green

Parameter	Value	Remarks
Communication Standards	CANopen	Full support for CANopen
	Baud Rate	10, 20, 50, 125, 250, 500, 800kbit/s, 1Mbit/s.
	ISO 11898	120Ohm terminated twisted pair, baud rate up to 1Mbit/s. External 120Ohm termination is required.
	Bosch CAN protocol specification 2.0, Part A, B.	For the internal CAN controller.
Protection	Short circuit to ground	
	Connection to the power supply	Only for 12V systems, 24V max.

8.7 General Specifications

Table 29. General Specifications

Parameter	Value	Remarks	
Internal Logic	User-Configurable	Interface	
		CANopen	Third-party software
		Modbus TCP	Third-party software
Firmware Update	In-system, through CANopen	Axiomatic Electronic Assistant, P/N: AX070502. Modbus TCP – currently not supported	
LED Indicators	CAN/System	Red/Green – CAN or System error/CAN link(activity). Flashing green/red– bootloader mode.	
	Ethernet	Yellow/Green – Ethernet speed/link(activity)	
Operating Temperature	-40...+85 °C	Industrial temperature range	
Environmental Protection	IP20	EN 60259	
Housing	Phoenix Contact ME MAX 22,5 G 2-2 KMGY - 2713638	Polyamide, Flammability V0 UL94, UL Recognized, EAC, China RoHS	
Electrical Connectors	Phoenix Contact MCO 1,5/5-G1L-3,5 - 2278380	J3 (Power/CAN/Ref#1), J5 (Bi/Univ Inputs)	
	Phoenix Contact MCO 1,5/5-G1R-3,5 - 2278351	J4 (Univ Inputs), J6 (Univ Inputs/Ref#2)	
	RJ-45	Ethernet, CAT5 (IEC 11801:2002)	
Installation	DIN Rail TH35-7.5 or TH35-15	EN 60715. Mounting Rail: 35 x 7.5mm or 35 x 15mm.	
Size	114.5 x 22.5 x 99 mm (4.508 x 0.89 x 3.898 in)	L(D) x W x H. See dimensional drawing	
	107 mm (4.213 in)	Depth from the top edge of DIN rail. See dimensional drawing	
Weight	0.136 kg (0.30 lb)		
Compliance	CE marking RoHS Directive		

8.8 Enclosure

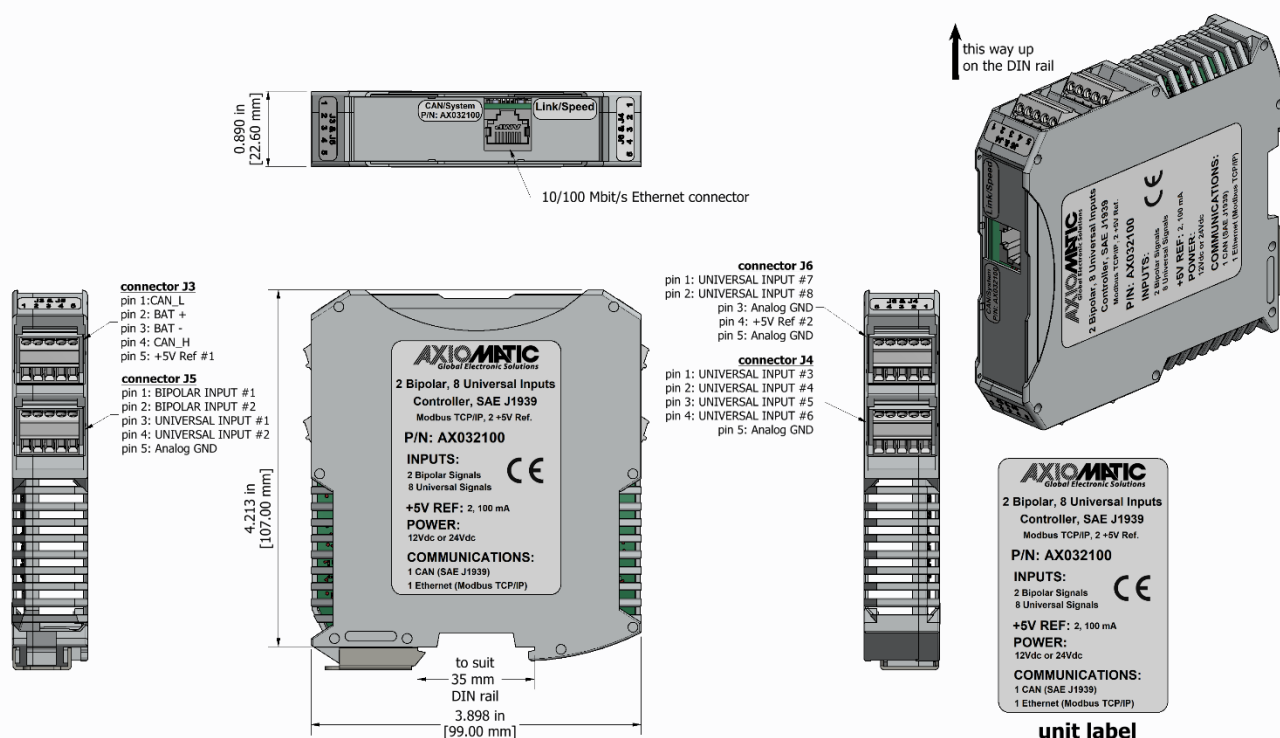

Figure 14. Dimensional Drawing – AX032101 (not shown) has the same dimensions and pinout

8.9 Electrical Connections

The controller has four 5-pin electrical connectors (except Ethernet) with the following pinouts.

Table 30. Connector Pinouts

Connector Pin Number	Connector Name			
	J3 (Power/CAN/Ref#1)	J5 (Bi/Univ Inputs)	J4 (Univ Inputs)	J6 (Univ Inputs/Ref#2)
1	CAN_L	Bipolar Input #1	Universal Input #3	Universal Input #7
2	BAT+	Bipolar Input #2	Universal Input #4	Universal Input #8
3	BAT-	Universal Input #1	Universal Input #5	Analog GND
4	CAN_H	Universal Input #2	Universal Input #6	+5V Ref #2
5	+5V Ref #1	Analog GND	Analog GND	Analog GND

Recommended mating connectors for J3...J6 are 5-pin 3.5 mm Phoenix Contact MC 1,5/5-ST-3,5 GY7035 – 1769087 screw terminal connectors with tension sleeves. They accept 28-16 AWG wires. A standard RJ-45 CAT5 or better plug can be used as a mating Ethernet connector.

8.10 Installation

For mechanical installation see information on the dimensional drawing. The CAN bus should be terminated on both sides with 120 Ohm resistors (0.25W minimum, metal film or similar type) between CAN_H and CAN_L.

9 MODBUS ADDRESS MAP

The following Modbus Address Map is used for the Modbus TCP communication with the controller.

Table 31. Modbus Address Map

Bit/Reg Address	Modbus Address		# of Reg	Name	Format	Default	Range	Units or Res.	Access	Description
	Dec	Hex								
Input Section										
Discrete Inputs										
101025	1024	0x0400	N/A	Bipolar Input #1	Bit	N/A	0...1	State	RO	
101026	1025	0x0401	N/A	Bipolar Input #2	Bit	N/A	0...1	State	RO	
101027	1026	0x0402	N/A	Universal Input #1	Bit	N/A	0...1	State	RO	
101028	1027	0x0403	N/A	Universal Input #2	Bit	N/A	0...1	State	RO	
101029	1028	0x0404	N/A	Universal Input #3	Bit	N/A	0...1	State	RO	
101030	1029	0x0405	N/A	Universal Input #4	Bit	N/A	0...1	State	RO	
101031	1030	0x0406	N/A	Universal Input #5	Bit	N/A	0...1	State	RO	
101032	1031	0x0407	N/A	Universal Input #6	Bit	N/A	0...1	State	RO	
101033	1032	0x0408	N/A	Universal Input #7	Bit	N/A	0...1	State	RO	
101034	1033	0x0409	N/A	Universal Input #8	Bit	N/A	0...1	State	RO	
Discrete Inputs										
301025	1024	0x0400	1	Discrete Inputs	Bits	N/A	0...0x3ff	1 bit per input	RO	Bit 0 (LSB) - Bipolar Input #1, Bit 1 -Bipolar Input #2, Bit 2 - Universal Input #1, ... Bit 9 - Universal Input #8. When an input is not in "Discrete Voltage Level" mode, the input state is 0.
Bipolar/Universal Inputs										
301026	1025	0x0401	2	Bipolar Input #1	Float	N/A	See input config	See config	RO	
301028	1027	0x0403	2	Bipolar Input #2	Float	N/A	See input config	See config	RO	
301030	1029	0x0405	2	Universal Input #1	Float	N/A	See input config	See config	RO	

Bit/Reg Address	Modbus Address		# of Reg	Name	Format	Default	Range	Units or Res.	Access	Description
	Dec	Hex								
301032	1031	0x0407	2	Universal Input #2	Float	N/A	See input config	See config	RO	
301034	1033	0x0409	2	Universal Input #3	Float	N/A	See input config	See config	RO	
301036	1035	0x040B	2	Universal Input #4	Float	N/A	See input config	See config	RO	
301038	1037	0x040D	2	Universal Input #5	Float	N/A	See input config	See config	RO	
301040	1039	0x040F	2	Universal Input #6	Float	N/A	See input config	See config	RO	
301042	1041	0x0411	2	Universal Input #7	Float	N/A	See input config	See config	RO	
301044	1043	0x0413	2	Universal Input #8	Float	N/A	See input config	See config	RO	
301046	1045	0x0415	11	Reserved	N/A	N/A	N/A	N/A	RO	Reserved for future use. Reading results in 0
Binary Function Outputs										
301057	1056	0x0420	2	Binary Function Output #1	Float	N/A	N/A	N/A	RO	
301059	1058	0x0422	2	Binary Function Output #2	Float	N/A	N/A	N/A	RO	
301061	1060	0x0424	2	Binary Function Output #3	Float	N/A	N/A	N/A	RO	
301063	1062	0x0426	2	Binary Function Output #4	Float	N/A	N/A	N/A	RO	
301065	1064	0x0428	2	Binary Function Output #5	Float	N/A	N/A	N/A	RO	
301067	1066	0x042A	2	Binary Function Output #6	Float	N/A	N/A	N/A	RO	
301069	1068	0x042C	2	Binary Function Output #7	Float	N/A	N/A	N/A	RO	
301071	1070	0x042E	2	Binary Function Output #8	Float	N/A	N/A	N/A	RO	
301073	1072	0x0430	2	Binary Function Output #9	Float	N/A	N/A	N/A	RO	
301075	1074	0x0432	2	Binary Function Output #10	Float	N/A	N/A	N/A	RO	

Bit/Reg Address	Modbus Address		# of Reg	Name	Format	Default	Range	Units or Res.	Access	Description
	Dec	Hex								
301077	1076	0x0434	12	Reserved	N/A	N/A	N/A	N/A	RO	Reserved for future use. Reading results in 0
CAN Inputs										
301089	1088	0x0440	2	CAN Input Signal #1	Float	N/A	See input config	See In config	RO	
301091	1090	0x0442	2	CAN Input Signal #2	Float	N/A	See input config	See In config	RO	
301093	1092	0x0444	2	CAN Input Signal #3	Float	N/A	See input config	See In config	RO	
301095	1094	0x0446	10	Reserved	N/A	N/A	N/A	N/A	RO	Reserved for future use. Reading results in 0
Auxiliary Signals										
301105	1104	0x0450	2	Global Discrete Constant Signal	Dword	N/A	N/A	N/A	RO	Equals to the <i>Global Discrete Constant Signal</i> configuration parameter
301107	1106	0x0452	2	Global Continuous Constant Signal	Float	N/A	N/A	N/A	RO	Equals to the <i>Global Continuous Constant Signal</i> configuration parameter
301109	1108	0x0454	2	Global Constant Signal = 0	Float	N/A	N/A	N/A	RO	Equals to zero
301111	1110	0x0456	2	Global Constant Signal = 1	Float	N/A	N/A	N/A	RO	Equals to one
301113	1112	0x0458	2	Supply Voltage	Float	N/A	Not Rated	V	RO	Covers rated supply voltage range
301115	1114	0x045A	2	Microcontroller Temperature	Float	N/A	Not Rated	Deg.C	RO	Covers rated temperature range
301117	1116	0x045C	4	Reserved	N/A	N/A	N/A	N/A	RO	Reserved for future use. Reading results in 0
Configuration Section										
Bipolar Input #1										
401025	1024	0x0400	1	Input Parameter	Byte	1 - Voltage	0 - Input Disabled, 1 - Voltage,	N/A	R/W	Defines the input parameter that will be measured by the input.

Bit/Reg Address	Modbus Address		# of Reg	Name	Format	Default	Range	Units or Res.	Access	Description
	Dec	Hex								
							2 - Current, 3 - Resistance (not used), 4 - Discrete Voltage Level, 5 - Frequency, 6 - PWM Duty Cycle			"Resistance" is not used. Writing "Resistance" will disable the input.
401026	1025	0x0401	1	Voltage Range	Byte	0 - 0...5V	0 - 0...5 V, 1 - 0...10 V, 2 - -5...5 V, 3 - -10...10 V	V	R/W	Used when Input Parameter is "Voltage"
401027	1026	0x0402	1	Current Range	Byte	0 - 0...20 mA	0 - 0...20mA, 1 - 4...20 mA	mA	R/W	Used when Input Parameter is "Current"
401028	1027	0x0403	1	Resistance Range	Byte	0	0	N/A	RO	Not used in Bipolar Inputs. Reading will always return 0, writing is allowed, but does not change the value.
401029	1028	0x0404	1	Voltage LoZ Input	Byte	0 - No	0 - No, 1 - Yes	N/A	R/W	Activates a 10kOhm pull-down resistor to avoid ghost voltages in the "Voltage" mode. Warning: Measurement accuracy will be decreased!
401030	1029	0x0405	1	Analog Input Filter	Byte	0 - Disabled	0 - Disabled, 1 - 50Hz Noise Rejection, 2 - 60Hz Noise Rejection, 3 - Both: 60Hz and 50Hz Noise Rejection	N/A	R/W	Noise Rejection in "Voltage" and "Current" mode.
401031	1030	0x0406	1	Pull-Up/Pull-Down Resistor	Byte	0 - Disabled	0 - Disabled, 1 - 10kOhm Pull-Up,	N/A	R/W	Used in "Discrete Voltage Level", "Frequency", and

Bit/Reg Address	Modbus Address		# of Reg	Name	Format	Default	Range	Units or Res.	Access	Description
	Dec	Hex								
							2 - 10kOhm Pull-Down			"PWM Duty Cycle" modes.
401032	1031	0x0407	1	Input Polarity	Byte	0 - Active High	0 - Active High, 1 - Active Low	N/A	R/W	Used in "Discrete Voltage Level", "Frequency", and "PWM Duty Cycle" modes.
401033	1032	0x0408	1	Discrete Input Debounce Time	Word	50ms	0...1000ms	ms	R/W	Used in "Discrete Voltage Level". If 0 - no debouncing.
401034	1033	0x0409	1	Frequency Range	Byte	0 - 1Hz...10kHz	0 - 1Hz...10kHz	Hz	R/W	One extended range is available due to 32bit counter. Used in "Frequency", and "PWM Duty Cycle" modes.
401035	1034	0x040A	1	Frequency/PWM Debounce Filter	Byte	0 - Disabled	0 - Disabled, 1 - 142ns, 2 - 1.14us, 3 - 6.10us	N/A	R/W	Used in "Frequency", and "PWM Duty Cycle" modes.
401036	1035	0x040B	1	Frequency/PWM Averaging	Byte	0 - No Averaging	0 - No Averaging, 1 - 3 Readings, 2 - 5 Readings, 3 - 10 Readings	N/A	R/W	Defines a moving average filter used in "Frequency", and "PWM Duty Cycle" modes.
401037	1036	0x040C	20	Reserved	N/A	N/A	N/A	N/A	RO	Reserved for future use. Reading results in 0. Writing is allowed but does not change the value.
Bipolar Input #2										
401057	1056	0x0420	1	Input Parameter	Byte	1 - Voltage	0 - Input Disabled, 1 - Voltage, 2 - Current, 3 -Resistance (not used), 4 - Discrete Voltage Level,	N/A	R/W	Defines the input parameter that will be measured by the input. "Resistance" is not used. Writing "Resistance" will disable the input.

Bit/Reg Address	Modbus Address		# of Reg	Name	Format	Default	Range	Units or Res.	Access	Description
	Dec	Hex								
							5 - Frequency, 6 - PWM Duty Cycle			
401058	1057	0x0421	1	Voltage Range	Byte	0 - 0...5V	0 - 0...5 V, 1 - 0...10 V, 2 - -5...5 V, 3 - -10...10 V	V	R/W	Used when Input Parameter is "Voltage"
401059	1058	0x0422	1	Current Range	Byte	0 - 0...20 mA	0 - 0...20mA, 1 - 4...20 mA	mA	R/W	Used when Input Parameter is "Current"
401060	1059	0x0423	1	Resistance Range	Byte	0	0	N/A	RO	Not used in Bipolar Inputs. Reading will always return 0, writing is allowed, but does not change the value.
401061	1060	0x0424	1	Voltage LoZ Input	Byte	0 - No	0 - No, 1 - Yes	N/A	R/W	Activates a 10kOhm pull-down resistor to avoid ghost voltages in the "Voltage" mode. Warning: Measurement accuracy will be decreased!
401062	1061	0x0425	1	Analog Input Filter	Byte	0 - Disabled	0 - Disabled, 1 - 50Hz Noise Rejection, 2 - 60Hz Noise Rejection, 3 - Both: 60Hz and 50Hz Noise Rejection	N/A	R/W	Noise Rejection in "Voltage" and "Current" modes.
401063	1062	0x0426	1	Pull-Up/Pull-Down Resistor	Byte	0 - Disabled	0 - Disabled, 1 - 10kOhm Pull-Up, 2 - 10 kOhm Pull-Down	N/A	R/W	Used in "Discrete Voltage Level", "Frequency", and "PWM Duty Cycle" modes.
401064	1063	0x0427	1	Input Polarity	Byte	0 - Active High	0 - Active High, 1 - Active Low	N/A	R/W	Used in "Discrete Voltage Level", "Frequency", and

Bit/Reg Address	Modbus Address		# of Reg	Name	Format	Default	Range	Units or Res.	Access	Description
	Dec	Hex								
										"PWM Duty Cycle" modes.
401065	1064	0x0428	1	Discrete Input Debounce Time	Word	50	0...1000ms	ms	R/W	Used in "Discrete Voltage Level". If 0 - no debouncing.
401066	1065	0x0429	1	Frequency Range	Byte	0 - 100Hz...10kHz	0 - 100Hz...10kHz, 1 - 10Hz...1kHz, 2 - 1Hz...100Hz	Hz	RO	A 16-bit shared counter is used. The parameter is configured in Universal Input #3. Writing is allowed but does not change the value. Used in "Frequency", and "PWM Duty Cycle" modes.
401067	1066	0x042A	1	Frequency/PWM Debounce Filter	Byte	0 - Disabled	0 - Disabled, 1 - 142ns, 2 - 1.14us, 3 - 6.10us	N/A	RO	The parameter is configured in Universal Input #3. Writing is allowed but does not change the value. Used in "Frequency", and "PWM Duty Cycle" modes.
401068	1067	0x042B	1	Frequency/PWM Averaging	Byte	0 - No Averaging	0 - No Averaging, 1 - 3 Readings, 2 - 5 Readings, 3 - 10 Readings	N/A	R/W	Defines a moving average filter. Used in "Frequency", and "PWM Duty Cycle" modes.
401069	1068	0x042C	20	Reserved	N/A	N/A	N/A	N/A	RO	Reserved for future use. Reading results in 0. Writing is allowed but does not change the value.
Universal Input #1										
401089	1088	0x0440	1	Input Parameter	Byte	1 - Voltage	0 - Input Disabled, 1 - Voltage, 2 - Current,	N/A	R/W	Defines the input parameter that will be measured by the input.

Bit/Reg Address	Modbus Address		# of Reg	Name	Format	Default	Range	Units or Res.	Access	Description
	Dec	Hex								
							3 - Resistance, 4 - Discrete Voltage Level, 5 - Frequency, 6 - PWM Duty Cycle			
401090	1089	0x0441	1	Voltage Range	Byte	0 - 0...5V	0 - 0...5 V, 1 - 0...10 V	V	R/W	Used when Input Parameter is "Voltage"
401091	1090	0x0442	1	Current Range	Byte	0 - 0...20 mA	0 - 0...20mA, 1 - 4...20 mA	mA	R/W	Used when Input Parameter is "Current"
401092	1091	0x0443	1	Resistance Range	Byte	0 - Auto Range	0 - Auto Range, 1 - 0...250Ohm, 2 - 0...2.5kOhm, 3 - 0...25kOhm, 4 - 0...250kOhm	Ohm	R/W	Used when Input Parameter is "Resistance"
401093	1092	0x0444	1	Voltage LoZ Input	Byte	0 - No	0 - No, 1 - Yes	N/A	R/W	Activates a 10kOhm pull-down resistor to avoid ghost voltages in the "Voltage" mode. Warning: Measurement accuracy will be decreased!
401094	1093	0x0445	1	Analog Input Filter	Byte	0 - Disabled	0 - Disabled, 1 - 50Hz Noise Rejection, 2 - 60Hz Noise Rejection, 3 - Both: 60Hz and 50Hz Noise Rejection	N/A	R/W	Noise Rejection in "Voltage", "Current" and "Resistance" modes.
401095	1094	0x0446	1	Pull-Up/Pull-Down Resistor	Byte	0 - Disabled	0 - Disabled, 1 - 10kOhm Pull-Up, 2 - 10 kOhm Pull-Down	N/A	R/W	Used in "Discrete Voltage Level", "Frequency", and "PWM Duty Cycle" modes.
401096	1095	0x0447	1	Input Polarity	Byte	0 - Active High	0 - Active High, 1 - Active Low	N/A	R/W	Used in "Discrete Voltage Level", "Frequency", and

Bit/Reg Address	Modbus Address		# of Reg	Name	Format	Default	Range	Units or Res.	Access	Description
	Dec	Hex								
										"PWM Duty Cycle" modes.
401097	1096	0x0448	1	Discrete Input Debounce Time	Word	50	0...1000ms	ms	R/W	Used in "Discrete Voltage Level". If 0 - no debouncing.
401098	1097	0x0449	1	Frequency Range	Byte	0 - 100Hz...10kHz	0 - 100Hz...10kHz, 1 - 10Hz...1kHz, 2 - 1Hz...100Hz	Hz	R/W	A 16-bit counter is shared with Universal Input #8. Used in "Frequency", and "PWM Duty Cycle" modes.
401099	1098	0x044A	1	Frequency/PWM Debounce Filter	Byte	0 - Disabled	0 - Disabled, 1 - 142ns, 2 - 1.14us, 3 - 6.10us	N/A	R/W	Shared with Universal Input #8. Used in "Frequency", and "PWM Duty Cycle" modes.
401100	1099	0x044B	1	Frequency/PWM Averaging	Byte	0 - No Averaging	0 - No Averaging, 1 - 3 Readings, 2 - 5 Readings, 3 - 10 Readings	N/A	R/W	Defines a moving average filter. Used in "Frequency", and "PWM Duty Cycle" modes.
401101	1100	0x044C	20	Reserved	N/A	N/A	N/A	N/A	RO	Reserved for future use. Reading results in 0. Writing is allowed but does not change the value.
Universal Input #2										
401121	1120	0x0460	1	Input Parameter	Byte	1 - Voltage	0 - Input Disabled, 1 - Voltage, 2 - Current, 3 - Resistance, 4 - Discrete Voltage Level, 5 - Frequency, 6 - PWM Duty Cycle	N/A	R/W	Defines the input parameter that will be measured by the input.
401122	1121	0x0461	1	Voltage Range	Byte	0 - 0...5V	0 - 0...5 V, 1 - 0...10 V	V	R/W	Used when Input Parameter is "Voltage"

Bit/Reg Address	Modbus Address		# of Reg	Name	Format	Default	Range	Units or Res.	Access	Description
	Dec	Hex								
401123	1122	0x0462	1	Current Range	Byte	0 - 0...20 mA	0 - 0...20mA, 1 - 4...20 mA	mA	R/W	Used when Input Parameter is "Current"
401124	1123	0x0463	1	Resistance Range	Byte	0 - Auto Range	0 - Auto Range, 1 -0...250Ohm, 2-0...2.5kOhm, 3- 0...25kOhm, 4-0...250kOhm	Ohm	R/W	Used when Input Parameter is "Resistance"
401125	1124	0x0464	1	Voltage LoZ Input	Byte	0 - No	0 - No, 1 - Yes	N/A	R/W	Activates a 10kOhm pull-down resistor to avoid ghost voltages in the "Voltage" mode. Warning: Measurement accuracy will be decreased!
401126	1125	0x0465	1	Analog Input Filter	Byte	0 - Disabled	0 - Disabled, 1 - 50Hz Noise Rejection, 2 - 60Hz Noise Rejection, 3 - Both: 60Hz and 50Hz Noise Rejection	N/A	R/W	Noise Rejection in "Voltage", "Current" and "Resistance" modes.
401127	1126	0x0466	1	Pull-Up/Pull-Down Resistor	Byte	0 - Disabled	0 - Disabled, 1 - 10kOhm Pull-Up, 2 - 10 kOhm Pull-Down	N/A	R/W	Used in "Discrete Voltage Level", "Frequency", and "PWM Duty Cycle" modes.
401128	1127	0x0467	1	Input Polarity	Byte	0 - Active High	0 - Active High, 1 - Active Low	N/A	R/W	Used in "Discrete Voltage Level", "Frequency", and "PWM Duty Cycle" modes.
401129	1128	0x0468	1	Discrete Input Debounce Time	Word	50	0...1000ms	ms	R/W	Used in "Discrete Voltage Level". If 0 - no debouncing.
401130	1129	0x0469	1	Frequency Range	Byte	0 - 100Hz...10kHz	0 - 100Hz...10kHz, 1 - 10Hz...1kHz, 2 - 1Hz...100Hz	Hz	R/W	A 16-bit counter is shared with Universal Input #5. Used in "Frequency",

Bit/Reg Address	Modbus Address		# of Reg	Name	Format	Default	Range	Units or Res.	Access	Description
	Dec	Hex								
										and "PWM Duty Cycle" modes.
401131	1130	0x046A	1	Frequency/PWM Debounce Filter	Byte	0 - Disabled	0 - Disabled, 1 - 142ns, 2 - 1.14us, 3 - 6.10us	N/A	R/W	Shared with Universal Input #5. Used in "Frequency", and "PWM Duty Cycle" modes.
401132	1131	0x046B	1	Frequency/PWM Averaging	Byte	0 - No Averaging	0 - No Averaging, 1 - 3 Readings, 2 - 5 Readings, 3 - 10 Readings	N/A	R/W	Defines a moving average filter. Used in "Frequency", and "PWM Duty Cycle" modes.
401133	1132	0x046C	20	Reserved	N/A	N/A	N/A	N/A	RO	Reserved for future use. Reading results in 0. Writing is allowed, but does not change the value.
Universal Input #3										
401153	1152	0x0480	1	Input Parameter	Byte	1 - Voltage	0 - Input Disabled, 1 - Voltage, 2 - Current, 3 -Resistance, 4 - Discrete Voltage Level, 5 - Frequency, 6 - PWM Duty Cycle	N/A	R/W	Defines the input parameter that will be measured by the input.
401154	1153	0x0481	1	Voltage Range	Byte	0 - 0...5V	0 - 0...5 V, 1 - 0...10 V	V	R/W	Used when Input Parameter is "Voltage"
401155	1154	0x0482	1	Current Range	Byte	0 - 0...20 mA	0 - 0...20mA, 1 - 4...20 mA	mA	R/W	Used when Input Parameter is "Current"
401156	1155	0x0483	1	Resistance Range	Byte	0 - Auto Range	0 - Auto Range, 1 -0...250Ohm, 2-0...2.5kOhm, 3- 0...25kOhm, 4-0...250kOhm	Ohm	R/W	Used when Input Parameter is "Resistance"
401157	1156	0x0484	1	Voltage LoZ Input	Byte	0 - No	0 - No, 1 - Yes	N/A	R/W	Activates a 10kOhm pull-down resistor to

Bit/Reg Address	Modbus Address		# of Reg	Name	Format	Default	Range	Units or Res.	Access	Description
	Dec	Hex								
										avoid ghost voltages in the "Voltage" mode. Warning: Measurement accuracy will be decreased!
401158	1157	0x0485	1	Analog Input Filter	Byte	0 - Disabled	0 - Disabled, 1 - 50Hz Noise Rejection, 2 - 60Hz Noise Rejection, 3 - Both: 60Hz and 50Hz Noise Rejection	N/A	R/W	Noise Rejection in "Voltage", "Current" and "Resistance" modes.
401159	1158	0x0486	1	Pull-Up/Pull-Down Resistor	Byte	0 - Disabled	0 - Disabled, 1 - 10kOhm Pull-Up, 2 - 10 kOhm Pull-Down	N/A	R/W	Used in "Discrete Voltage Level", "Frequency", and "PWM Duty Cycle" modes.
401160	1159	0x0487	1	Input Polarity	Byte	0 - Active High	0 - Active High, 1 - Active Low	N/A	R/W	Used in "Discrete Voltage Level", "Frequency", and "PWM Duty Cycle" modes.
401161	1160	0x0488	1	Discrete Input Debounce Time	Word	50	0...1000ms	ms	R/W	Used in "Discrete Voltage Level". If 0 - no debouncing.
401162	1161	0x0489	1	Frequency Range	Byte	0 - 100Hz...10kHz	0 - 100Hz...10kHz, 1 - 10Hz...1kHz, 2 - 1Hz...100Hz	Hz	R/W	A 16-bit counter is shared with Bipolar Input #2. Used in "Frequency", and "PWM Duty Cycle" modes.
401163	1162	0x048A	1	Frequency/PWM Debounce Filter	Byte	0 - Disabled	0 - Disabled, 1 - 142ns, 2 - 1.14us, 3 - 6.10us	N/A	R/W	Shared with Bipolar Input #2. Used in "Frequency", and "PWM Duty Cycle" modes.
401164	1163	0x048B	1	Frequency/PWM Averaging	Byte	0 - No Averaging	0 - No Averaging, 1 - 3 Readings,	N/A	R/W	Defines a moving average filter.

Bit/Reg Address	Modbus Address		# of Reg	Name	Format	Default	Range	Units or Res.	Access	Description
	Dec	Hex								
							2 - 5 Readings, 3 - 10 Readings			Used in "Frequency", and "PWM Duty Cycle" modes.
401165	1164	0x048C	20	Reserved	N/A	N/A	N/A	N/A	RO	Reserved for future use. Reading results in 0. Writing is allowed but does not change the value.
Universal Input #4										
401185	1184	0x04A0	1	Input Parameter	Byte	1 - Voltage	0 - Input Disabled, 1 - Voltage, 2 - Current, 3 -Resistance, 4 - Discrete Voltage Level, 5 - Frequency, 6 - PWM Duty Cycle	N/A	R/W	Defines the input parameter that will be measured by the input.
401186	1185	0x04A1	1	Voltage Range	Byte	0 - 0...5V	0 - 0...5 V, 1 - 0...10 V	V	R/W	Used when Input Parameter is "Voltage"
401187	1186	0x04A2	1	Current Range	Byte	0 - 0...20 mA	0 - 0...20mA, 1 - 4...20 mA	mA	R/W	Used when Input Parameter is "Current"
401188	1187	0x04A3	1	Resistance Range	Byte	0 - Auto Range	0 - Auto Range, 1 -0...250Ohm, 2-0...2.5kOhm, 3-0...25kOhm, 4-0...250kOhm	Ohm	R/W	Used when Input Parameter is "Resistance"
401189	1188	0x04A4	1	Voltage LoZ Input	Byte	0 - No	0 - No, 1 - Yes	N/A	R/W	Activates a 10kOhm pull-down resistor to avoid ghost voltages in the "Voltage" mode. Warning: Measurement accuracy will be decreased!
401190	1189	0x04A5	1	Analog Input Filter	Byte	0 - Disabled	0 - Disabled, 1 - 50Hz Noise Rejection, 2 - 60Hz Noise	N/A	R/W	Noise Rejection in "Voltage", "Current" and "Resistance" modes.

Bit/Reg Address	Modbus Address		# of Reg	Name	Format	Default	Range	Units or Res.	Access	Description
	Dec	Hex								
							Rejection, 3 - Both: 60Hz and 50Hz Noise Rejection			
401191	1190	0x04A6	1	Pull-Up/Pull-Down Resistor	Byte	0 - Disabled	0 - Disabled, 1 - 10kOhm Pull-Up, 2 - 10 kOhm Pull-Down	N/A	R/W	Used in "Discrete Voltage Level", "Frequency", and "PWM Duty Cycle" modes.
401192	1191	0x04A7	1	Input Polarity	Byte	0 - Active High	0 - Active High, 1 - Active Low	N/A	R/W	Used in "Discrete Voltage Level", "Frequency", and "PWM Duty Cycle" modes.
401193	1192	0x04A8	1	Discrete Input Debounce Time	Word	50	0...1000ms	ms	R/W	Used in "Discrete Voltage Level". If 0 - no debouncing.
401194	1193	0x04A9	1	Frequency Range	Byte	0 - 100Hz...10kHz	0 - 100Hz...10kHz, 1 - 10Hz...1kHz, 2 - 1Hz...100Hz	Hz	R/W	A 16-bit counter is used. Used in "Frequency", and "PWM Duty Cycle" modes.
401195	1194	0x04AA	1	Frequency/PWM Debounce Filter	Byte	0 - Disabled	0 - Disabled, 1 - 142ns, 2 - 1.14us, 3 - 6.10us	N/A	R/W	Used in "Frequency", and "PWM Duty Cycle" modes.
401196	1195	0x04AB	1	Frequency/PWM Averaging	Byte	0 - No Averaging	0 - No Averaging, 1 - 3 Readings, 2 - 5 Readings, 3 - 10 Readings	N/A	R/W	Defines a moving average filter. Used in "Frequency", and "PWM Duty Cycle" modes.
401197	1196	0x04AC	20	Reserved	N/A	N/A	N/A	N/A	RO	Reserved for future use. Reading results in 0. Writing is allowed but does not change the value.

Universal Input #5

Bit/Reg Address	Modbus Address		# of Reg	Name	Format	Default	Range	Units or Res.	Access	Description
	Dec	Hex								
401217	1216	0x04C0	1	Input Parameter	Byte	1 - Voltage	0 - Input Disabled, 1 - Voltage, 2 - Current, 3 -Resistance, 4 - Discrete Voltage Level, 5 - Frequency, 6 - PWM Duty Cycle	N/A	R/W	Defines the input parameter that will be measured by the input.
401218	1217	0x04C1	1	Voltage Range	Byte	0 - 0...5V	0 - 0...5 V, 1 - 0...10 V	V	R/W	Used when Input Parameter is "Voltage"
401219	1218	0x04C2	1	Current Range	Byte	0 - 0...20 mA	0 - 0...20mA, 1 - 4...20 mA	mA	R/W	Used when Input Parameter is "Current"
401220	1219	0x04C3	1	Resistance Range	Byte	0 - Auto Range	0 - Auto Range, 1 -0...250Ohm, 2-0...2.5kOhm, 3- 0...25kOhm, 4-0...250kOhm	Ohm	R/W	Used when Input Parameter is "Resistance"
401221	1220	0x04C4	1	Voltage LoZ Input	Byte	0 - No	0 - No, 1 - Yes	N/A	R/W	Activates a 10kOhm pull-down resistor to avoid ghost voltages in the "Voltage" mode. Warning: Measurement accuracy will be decreased!
401222	1221	0x04C5	1	Analog Input Filter	Byte	0 - Disabled	0 - Disabled, 1 - 50Hz Noise Rejection, 2 - 60Hz Noise Rejection, 3 - Both: 60Hz and 50Hz Noise Rejection	N/A	R/W	Noise Rejection in "Voltage", "Current" and "Resistance" modes.
401223	1222	0x04C6	1	Pull-Up/Pull-Down Resistor	Byte	0 - Disabled	0 - Disabled, 1 - 10kOhm Pull-Up, 2 - 10 kOhm Pull-Down	N/A	R/W	Used in "Discrete Voltage Level", "Frequency", and "PWM Duty Cycle" modes.

Bit/Reg Address	Modbus Address		# of Reg	Name	Format	Default	Range	Units or Res.	Access	Description
	Dec	Hex								
401224	1223	0x04C7	1	Input Polarity	Byte	0 - Active High	0 - Active High, 1 - Active Low	N/A	R/W	Used in "Discrete Voltage Level", "Frequency", and "PWM Duty Cycle" modes.
401225	1224	0x04C8	1	Discrete Input Debounce Time	Word	50	0...1000ms	ms	R/W	Used in "Discrete Voltage Level". If 0 - no debouncing.
401226	1225	0x04C9	1	Frequency Range	Byte	0 - 100Hz...10kHz	0 - 100Hz...10kHz, 1 - 10Hz...1kHz, 2 - 1Hz...100Hz	Hz	RO	A 16-bit shared counter is used. The parameter is configured in Universal Input #2. Writing is allowed but does not change the value. Used in "Frequency", and "PWM Duty Cycle" modes.
401227	1226	0x04CA	1	Frequency/PWM Debounce Filter	Byte	0 - Disabled	0 - Disabled, 1 - 142ns, 2 - 1.14us, 3 - 6.10us	N/A	RO	The parameter is configured in Universal Input #2. Writing is allowed but does not change the value. Used in "Frequency", and "PWM Duty Cycle" modes.
401228	1227	0x04CB	1	Frequency/PWM Averaging	Byte	0 - No Averaging	0 - No Averaging, 1 - 3 Readings, 2 - 5 Readings, 3 - 10 Readings	N/A	R/W	Defines a moving average filter. Used in "Frequency", and "PWM Duty Cycle" modes.
401229	1228	0x04CC	20	Reserved	N/A	N/A	N/A	N/A	RO	Reserved for future use. Reading results in 0. Writing is allowed but does not change the value.

Universal Input #6

Bit/Reg Address	Modbus Address		# of Reg	Name	Format	Default	Range	Units or Res.	Access	Description
	Dec	Hex								
401249	1248	0x04E0	1	Input Parameter	Byte	1 - Voltage	0 - Input Disabled, 1 - Voltage, 2 - Current, 3 -Resistance, 4 - Discrete Voltage Level, 5 - Frequency, 6 - PWM Duty Cycle	N/A	R/W	Defines the input parameter that will be measured by the input.
401250	1249	0x04E1	1	Voltage Range	Byte	0 - 0...5V	0 - 0...5 V, 1 - 0...10 V	V	R/W	Used when Input Parameter is "Voltage"
401251	1250	0x04E2	1	Current Range	Byte	0 - 0...20 mA	0 - 0...20mA, 1 - 4...20 mA	mA	R/W	Used when Input Parameter is "Current"
401252	1251	0x04E3	1	Resistance Range	Byte	0 - Auto Range	0 - Auto Range, 1 -0...250Ohm, 2-0...2.5kOhm, 3 -0...25kOhm, 4-0...250kOhm	Ohm	R/W	Used when Input Parameter is "Resistance"
401253	1252	0x04E4	1	Voltage LoZ Input	Byte	0 - No	0 - No, 1 - Yes	N/A	R/W	Activates a 10kOhm pull-down resistor to avoid ghost voltages in the "Voltage" mode. Warning: Measurement accuracy will be decreased!
401254	1253	0x04E5	1	Analog Input Filter	Byte	0 - Disabled	0 - Disabled, 1 - 50Hz Noise Rejection, 2 - 60Hz Noise Rejection, 3 - Both: 60Hz and 50Hz Noise Rejection	N/A	R/W	Noise Rejection in "Voltage", "Current" and "Resistance" modes.
401255	1254	0x04E6	1	Pull-Up/Pull-Down Resistor	Byte	0 - Disabled	0 - Disabled, 1 - 10kOhm Pull-Up, 2 - 10 kOhm Pull-Down	N/A	R/W	Used in "Discrete Voltage Level", "Frequency", and "PWM Duty Cycle" modes.

Bit/Reg Address	Modbus Address		# of Reg	Name	Format	Default	Range	Units or Res.	Access	Description
	Dec	Hex								
401256	1255	0x04E7	1	Input Polarity	Byte	0 - Active High	0 - Active High, 1 - Active Low	N/A	R/W	Used in "Discrete Voltage Level", "Frequency", and "PWM Duty Cycle" modes.
401257	1256	0x04E8	1	Discrete Input Debounce Time	Word	50	0...1000ms	ms	R/W	Used in "Discrete Voltage Level". If 0 - no debouncing.
401258	1257	0x04E9	1	Frequency Range	Byte	0 - 100Hz...10kHz	0 - 100Hz...10kHz, 1 - 10Hz...1kHz, 2 - 1Hz...100Hz	Hz	R/W	A 16-bit counter is used. Used in "Frequency", and "PWM Duty Cycle" modes.
401259	1258	0x04EA	1	Frequency/PWM Debounce Filter	Byte	0 - Disabled	0 - Disabled, 1 - 142ns, 2 - 1.14us, 3 - 6.10us	N/A	R/W	Used in "Frequency", and "PWM Duty Cycle" modes.
401260	1259	0x04EB	1	Frequency/PWM Averaging	Byte	0 - No Averaging	0 - No Averaging, 1 - 3 Readings, 2 - 5 Readings, 3 - 10 Readings	N/A	R/W	Defines a moving average filter. Used in "Frequency", and "PWM Duty Cycle" modes.
401261	1260	0x04EC	20	Reserved	N/A	N/A	N/A	N/A	RO	Reserved for future use. Reading results in 0. Writing is allowed but does not change the value.
Universal Input #7										
401281	1280	0x0500	1	Input Parameter	Byte	1 - Voltage	0 - Input Disabled, 1 - Voltage, 2 - Current, 3 -Resistance, 4 - Discrete Voltage Level, 5 - Frequency, 6 - PWM Duty Cycle	N/A	R/W	Defines the input parameter that will be measured by the input.

Bit/Reg Address	Modbus Address		# of Reg	Name	Format	Default	Range	Units or Res.	Access	Description
	Dec	Hex								
401282	1281	0x0501	1	Voltage Range	Byte	0 - 0...5V	0 - 0...5 V, 1 - 0...10 V	V	R/W	Used when Input Parameter is "Voltage"
401283	1282	0x0502	1	Current Range	Byte	0 - 0...20 mA	0 - 0...20mA, 1 - 4...20 mA	mA	R/W	Used when Input Parameter is "Current"
401284	1283	0x0503	1	Resistance Range	Byte	0 - Auto Range	0 - Auto Range, 1- 0...250Ohm, 2-0...2.5kOhm, 3-0...25kOhm, 4-0...250kOhm	Ohm	R/W	Used when Input Parameter is "Resistance"
401285	1284	0x0504	1	Voltage LoZ Input	Byte	0 - No	0 - No, 1 - Yes	N/A	R/W	Activates a 10kOhm pull-down resistor to avoid ghost voltages in the "Voltage" mode. Warning: Measurement accuracy will be decreased!
401286	1285	0x0505	1	Analog Input Filter	Byte	0 - Disabled	0 - Disabled, 1 - 50Hz Noise Rejection, 2 - 60Hz Noise Rejection, 3 - Both: 60Hz and 50Hz Noise Rejection	N/A	R/W	Noise Rejection in "Voltage", "Current" and "Resistance" modes.
401287	1286	0x0506	1	Pull-Up/Pull-Down Resistor	Byte	0 - Disabled	0 - Disabled, 1 - 10kOhm Pull-Up, 2 - 10 kOhm Pull-Down	N/A	R/W	Used in "Discrete Voltage Level", "Frequency", and "PWM Duty Cycle" modes.
401288	1287	0x0507	1	Input Polarity	Byte	0 - Active High	0 - Active High, 1 - Active Low	N/A	R/W	Used in "Discrete Voltage Level", "Frequency", and "PWM Duty Cycle" modes.
401289	1288	0x0508	1	Discrete Input Debounce Time	Word	50	0...1000ms	ms	R/W	Used in "Discrete Voltage Level". If 0 - no debouncing.
401290	1289	0x0509	1	Frequency Range	Byte	0 - 100Hz...10kHz	0 - 100Hz...10kHz,	Hz	R/W	A 16-bit counter is used.

Bit/Reg Address	Modbus Address		# of Reg	Name	Format	Default	Range	Units or Res.	Access	Description
	Dec	Hex								
							1 - 10Hz...1kHz, 2 - 1Hz...100Hz			Used in "Frequency", and "PWM Duty Cycle" modes.
401291	1290	0x050A	1	Frequency/PWM Debounce Filter	Byte	0 - Disabled	0 - Disabled, 1 - 142ns, 2 - 1.14us, 3 - 6.10us	N/A	R/W	Used in "Frequency", and "PWM Duty Cycle" modes.
401292	1291	0x050B	1	Frequency/PWM Averaging	Byte	0 - No Averaging	0 - No Averaging, 1 - 3 Readings, 2 - 5 Readings, 3 - 10 Readings	N/A	R/W	Defines a moving average filter. Used in "Frequency", and "PWM Duty Cycle" modes.
401293	1292	0x050C	20	Reserved	N/A	N/A	N/A	N/A	RO	Reserved for future use. Reading results in 0. Writing is allowed but does not change the value.
Universal Input #8										
401313	1312	0x0520	1	Input Parameter	Byte	1 - Voltage	0 - Input Disabled, 1 - Voltage, 2 - Current, 3 -Resistance, 4 - Discrete Voltage Level, 5 - Frequency, 6 - PWM Duty Cycle	N/A	R/W	Defines the input parameter that will be measured by the input.
401314	1313	0x0521	1	Voltage Range	Byte	0 - 0...5V	0 - 0...5 V, 1 - 0...10 V	V	R/W	Used when Input Parameter is "Voltage"
401315	1314	0x0522	1	Current Range	Byte	0 - 0...20 mA	0 - 0...20mA, 1 - 4...20 mA	mA	R/W	Used when Input Parameter is "Current"
401316	1315	0x0523	1	Resistance Range	Byte	0 - Auto Range	0 - Auto Range, 1 -0...250Ohm, 2-0...2.5kOhm, 3- 0...25kOhm, 4-0...250kOhm	Ohm	R/W	Used when Input Parameter is "Resistance"
401317	1316	0x0524	1	Voltage LoZ Input	Byte	0 - No	0 - No, 1 - Yes	N/A	R/W	Activates a 10kOhm pull-down resistor to

Bit/Reg Address	Modbus Address		# of Reg	Name	Format	Default	Range	Units or Res.	Access	Description
	Dec	Hex								
										avoid ghost voltages in the "Voltage" mode. Warning: Measurement accuracy will be decreased!
401318	1317	0x0525	1	Analog Input Filter	Byte	0 - Disabled	0 - Disabled, 1 - 50Hz Noise Rejection, 2 - 60Hz Noise Rejection, 3 - Both: 60Hz and 50Hz Noise Rejection	N/A	R/W	Noise Rejection in "Voltage", "Current" and "Resistance" modes.
401319	1318	0x0526	1	Pull-Up/Pull-Down Resistor	Byte	0 - Disabled	0 - Disabled, 1 - 10kOhm Pull-Up, 2 - 10 kOhm Pull-Down	N/A	R/W	Used in "Discrete Voltage Level", "Frequency", and "PWM Duty Cycle" modes.
401320	1319	0x0527	1	Input Polarity	Byte	0 - Active High	0 - Active High, 1 - Active Low	N/A	R/W	Used in "Discrete Voltage Level", "Frequency", and "PWM Duty Cycle" modes.
401321	1320	0x0528	1	Discrete Input Debounce Time	Word	50	0...1000ms	ms	R/W	Used in "Discrete Voltage Level". If 0 - no debouncing.
401322	1321	0x0529	1	Frequency Range	Byte	0 - 100Hz...10kHz	0 - 100Hz...10kHz, 1 - 10Hz...1kHz, 2 - 1Hz...100Hz	Hz	RO	A 16-bit shared counter is used. The parameter is configured in Universal Input #1. Writing is allowed but does not change the value. Used in "Frequency", and "PWM Duty Cycle" modes.
401323	1322	0x052A	1	Frequency/PWM Debounce Filter	Byte	0 - Disabled	0 - Disabled, 1 - 142ns,	N/A	RO	The parameter is configured in Universal Input #1.

Bit/Reg Address	Modbus Address		# of Reg	Name	Format	Default	Range	Units or Res.	Access	Description
	Dec	Hex								
							2 - 1.14us, 3 - 6.10us			Writing is allowed but does not change the value. Used in "Frequency", and "PWM Duty Cycle" modes.
401324	1323	0x052B	1	Frequency/PWM Averaging	Byte	0 - No Averaging	0 - No Averaging, 1 - 3 Readings, 2 - 5 Readings, 3 - 10 Readings	N/A	R/W	Defines a moving average filter. Used in "Frequency", and "PWM Duty Cycle" modes.
401325	1324	0x052C	20	Reserved	N/A	N/A	N/A	N/A	RO	Reserved for future use. Reading results in 0. Writing is allowed but does not change the value.
Binary Function #1										
401345	1344	0x0540	1	Binary Function	Byte	0 - Undefined	See Table 20. Binary Functions	N/A	R/W	F[x;y] – Binary function
401346	1345	0x0541	2	Output Scale	Float	1	Any value	N/A	R/W	A – Output Scale
401348	1347	0x0543	2	Output Offset	Float	0	Any value	N/A	R/W	B – Output Offset
401350	1349	0x0545	1	Input #1 Signal Source	Byte	0 - Not Connected	Any signal output of any function block or "Not connected". See Table 6. Controller Signal Sources	N/A	R/W	X1 – Input Signal #1
401351	1350	0x0546	1	Input #1 Signal Default	Byte	0 - No	0 - No, 1 - Yes	N/A	R/W	Defines whether the default signal value for X1 is defined.
401352	1351	0x0547	2	Input #1 Signal Default Value	Float	0	Any value	N/A	R/W	X1 default value, if Input #1 Signal Default is "Yes".
401354	1353	0x0549	1	Unary Function #1	Byte	0 - Undefined	See Table 19. Unary Functions	N/A	R/W	f1(x) – Unary function #1
401355	1354	0x054A	2	Scale #1	Float	1	Any value	N/A	R/W	a1 – Scale #1
401357	1356	0x054C	2	Offset #1	Float	0	Any value	N/A	R/W	b1 – Offset #1

Bit/Reg Address	Modbus Address		# of Reg	Name	Format	Default	Range	Units or Res.	Access	Description
	Dec	Hex								
401359	1358	0x054E	1	Input #2 Signal Source	Byte	0 - Not Connected	Any signal output of any function block or "Not connected". See Table 6. Controller Signal Sources	N/A	R/W	X2 – Input Signal #2
401360	1359	0x054F	1	Input #2 Signal Default	Byte	0 - No	0 - No, 1 - Yes	N/A	R/W	Defines whether the default signal value for X2 is defined.
401361	1360	0x0550	2	Input #2 Signal Default Value	Float	0	Any value	N/A	R/W	X2 default value, if Input #2 Signal Default is Yes.
401363	1362	0x0552	1	Unary Function #2	Byte	0 - Undefined	See Table 19. Unary Functions	N/A	R/W	f2(x) – Unary function #2
401364	1363	0x0553	2	Scale #2	Float	1	Any value	N/A	R/W	a2 – Scale #2
401366	1365	0x0555	2	Offset #2	Float	0	Any value	N/A	R/W	b2 – Offset #2
401368	1367	0x0557	9	Reserved	N/A	N/A	N/A	N/A	RO	Reserved for future use. Reading results in 0. Writing is allowed but does not change the value.
Binary Function #2										
401377	1376	0x0560	1	Binary Function	Byte	0 - Undefined	See Table 20. Binary Functions	N/A	R/W	F[x;y] – Binary function
401378	1377	0x0561	2	Output Scale	Float	1	Any value	N/A	R/W	A – Output Scale
401380	1379	0x0563	2	Output Offset	Float	0	Any value	N/A	R/W	B – Output Offset
401382	1381	0x0565	1	Input #1 Signal Source	Byte	0 - Not Connected	Any signal output of any function block or "Not connected". See Table 6. Controller Signal Sources	N/A	R/W	X1 – Input Signal #1
401383	1382	0x0566	1	Input #1 Signal Default	Byte	0 - No	0 - No, 1 - Yes	N/A	R/W	Defines whether the default signal value for X1 is defined.

Bit/Reg Address	Modbus Address		# of Reg	Name	Format	Default	Range	Units or Res.	Access	Description
	Dec	Hex								
401384	1383	0x0567	2	Input #1 Signal Default Value	Float	0	Any value	N/A	R/W	X1 default value, if Input #1 Signal Default is "Yes".
401386	1385	0x0569	1	Unary Function #1	Byte	0 - Undefined	See Table 19. Unary Functions	N/A	R/W	f1(x) – Unary function #1
401387	1386	0x056A	2	Scale #1	Float	1	Any value	N/A	R/W	a1 – Scale #1
401389	1388	0x056C	2	Offset #1	Float	0	Any value	N/A	R/W	b1 – Offset #1
401391	1390	0x056E	1	Input #2 Signal Source	Byte	0 - Not Connected	Any signal output of any function block or "Not connected". See Table 6. Controller Signal Sources	N/A	R/W	X2 – Input Signal #2
401392	1391	0x056F	1	Input #2 Signal Default	Byte	0 - No	0 - No, 1 - Yes	N/A	R/W	Defines whether the default signal value for X2 is defined.
401393	1392	0x0570	2	Input #2 Signal Default Value	Float	0	Any value	N/A	R/W	X2 default value, if Input #2 Signal Default is Yes.
401395	1394	0x0572	1	Unary Function #2	Byte	0 - Undefined	See Table 19. Unary Functions	N/A	R/W	f2(x) – Unary function #2
401396	1395	0x0573	2	Scale #2	Float	1	Any value	N/A	R/W	a2 – Scale #2
401398	1397	0x0575	2	Offset #2	Float	0	Any value	N/A	R/W	b2 – Offset #2
401400	1399	0x0577	9	Reserved	N/A	N/A	N/A	N/A	RO	Reserved for future use. Reading results in 0. Writing is allowed but does not change the value.
Binary Function #3										
401409	1408	0x0580	1	Binary Function	Byte	0 - Undefined	See Table 20. Binary Functions	N/A	R/W	F[x;y] – Binary function
401410	1409	0x0581	2	Output Scale	Float	1	Any value	N/A	R/W	A – Output Scale
401412	1411	0x0583	2	Output Offset	Float	0	Any value	N/A	R/W	B – Output Offset
401414	1413	0x0585	1	Input #1 Signal Source	Byte	0 - Not Connected	Any signal output of any function block or "Not connected". See Table 6.	N/A	R/W	X1 – Input Signal #1

Bit/Reg Address	Modbus Address		# of Reg	Name	Format	Default	Range	Units or Res.	Access	Description
	Dec	Hex								
							Controller Signal Sources			
401415	1414	0x0586	1	Input #1 Signal Default	Byte	0 - No	0 - No, 1 - Yes	N/A	R/W	Defines whether the default signal value for X1 is defined.
401416	1415	0x0587	2	Input #1 Signal Default Value	Float	0	Any value	N/A	R/W	X1 default value, if Input #1 Signal Default is "Yes".
401418	1417	0x0589	1	Unary Function #1	Byte	0 - Undefined	See Table 19. Unary Functions	N/A	R/W	f1(x) – Unary function #1
401419	1418	0x058A	2	Scale #1	Float	1	Any value	N/A	R/W	a1 – Scale #1
401421	1420	0x058C	2	Offset #1	Float	0	Any value	N/A	R/W	b1 – Offset #1
401423	1422	0x058E	1	Input #2 Signal Source	Byte	0 - Not Connected	Any signal output of any function block or "Not connected". See Table 6. Controller Signal Sources	N/A	R/W	X2 – Input Signal #2
401424	1423	0x058F	1	Input #2 Signal Default	Byte	0 - No	0 - No, 1 - Yes	N/A	R/W	Defines whether the default signal value for X2 is defined.
401425	1424	0x0590	2	Input #2 Signal Default Value	Float	0	Any value	N/A	R/W	X2 default value, if Input #2 Signal Default is Yes.
401427	1426	0x0592	1	Unary Function #2	Byte	0 - Undefined	See Table 19. Unary Functions	N/A	R/W	f2(x) – Unary function #2
401428	1427	0x0593	2	Scale #2	Float	1	Any value	N/A	R/W	a2 – Scale #2
401430	1429	0x0595	2	Offset #2	Float	0	Any value	N/A	R/W	b2 – Offset #2
401432	1431	0x0597	9	Reserved	N/A	N/A	N/A	N/A	RO	Reserved for future use. Reading results in 0. Writing is allowed but does not change the value.
Binary Function #4										
401441	1440	0x05A0	1	Binary Function	Byte	0 - Undefined	See Table 20. Binary Functions	N/A	R/W	F[x;y] – Binary function
401442	1441	0x05A1	2	Output Scale	Float	1	Any value	N/A	R/W	A – Output Scale
401444	1443	0x05A3	2	Output Offset	Float	0	Any value	N/A	R/W	B – Output Offset

Bit/Reg Address	Modbus Address		# of Reg	Name	Format	Default	Range	Units or Res.	Access	Description
	Dec	Hex								
401446	1445	0x05A5	1	Input #1 Signal Source	Byte	0 - Not Connected	Any signal output of any function block or "Not connected". See Table 6. Controller Signal Sources	N/A	R/W	X1 – Input Signal #1
401447	1446	0x05A6	1	Input #1 Signal Default	Byte	0 - No	0 - No, 1 - Yes	N/A	R/W	Defines whether the default signal value for X1 is defined.
401448	1447	0x05A7	2	Input #1 Signal Default Value	Float	0	Any value	N/A	R/W	X1 default value, if Input #1 Signal Default is "Yes".
401450	1449	0x05A9	1	Unary Function #1	Byte	0 - Undefined	See Table 19. Unary Functions	N/A	R/W	f1(x) – Unary function #1
401451	1450	0x05AA	2	Scale #1	Float	1	Any value	N/A	R/W	a1 – Scale #1
401453	1452	0x05AC	2	Offset #1	Float	0	Any value	N/A	R/W	b1 – Offset #1
401455	1454	0x05AE	1	Input #2 Signal Source	Byte	0 - Not Connected	Any signal output of any function block or "Not connected". See Table 6. Controller Signal Sources	N/A	R/W	X2 – Input Signal #2
401456	1455	0x05AF	1	Input #2 Signal Default	Byte	0 - No	0 - No, 1 - Yes	N/A	R/W	Defines whether the default signal value for X2 is defined.
401457	1456	0x05B0	2	Input #2 Signal Default Value	Float	0	Any value	N/A	R/W	X2 default value, if Input #2 Signal Default is Yes.
401459	1458	0x05B2	1	Unary Function #2	Byte	0 - Undefined	See Table 19. Unary Functions	N/A	R/W	f2(x) – Unary function #2
401460	1459	0x05B3	2	Scale #2	Float	1	Any value	N/A	R/W	a2 – Scale #2
401462	1461	0x05B5	2	Offset #2	Float	0	Any value	N/A	R/W	b2 – Offset #2
401464	1463	0x05B7	9	Reserved	N/A	N/A	N/A	N/A	RO	Reserved for future use. Reading results in 0. Writing is allowed but does not change the value.

Bit/Reg Address	Modbus Address		# of Reg	Name	Format	Default	Range	Units or Res.	Access	Description
	Dec	Hex								
Binary Function #5										
401473	1472	0x05C0	1	Binary Function	Byte	0 - Undefined	See Table 20. Binary Functions	N/A	R/W	F[x;y] – Binary function
401474	1473	0x05C1	2	Output Scale	Float	1	Any value	N/A	R/W	A – Output Scale
401476	1475	0x05C3	2	Output Offset	Float	0	Any value	N/A	R/W	B – Output Offset
401478	1477	0x05C5	1	Input #1 Signal Source	Byte	0 - Not Connected	Any signal output of any function block or "Not connected". See Table 6. Controller Signal Sources	N/A	R/W	X1 – Input Signal #1
401479	1478	0x05C6	1	Input #1 Signal Default	Byte	0 - No	0 - No, 1 - Yes	N/A	R/W	Defines whether the default signal value for X1 is defined.
401480	1479	0x05C7	2	Input #1 Signal Default Value	Float	0	Any value	N/A	R/W	X1 default value, if Input #1 Signal Default is "Yes".
401482	1481	0x05C9	1	Unary Function #1	Byte	0 - Undefined	See Table 19. Unary Functions	N/A	R/W	f1(x) – Unary function #1
401483	1482	0x05CA	2	Scale #1	Float	1	Any value	N/A	R/W	a1 – Scale #1
401485	1484	0x05CC	2	Offset #1	Float	0	Any value	N/A	R/W	b1 – Offset #1
401487	1486	0x05CE	1	Input #2 Signal Source	Byte	0 - Not Connected	Any signal output of any function block or "Not connected". See Table 6. Controller Signal Sources	N/A	R/W	X2 – Input Signal #2
401488	1487	0x05CF	1	Input #2 Signal Default	Byte	0 - No	0 - No, 1 - Yes	N/A	R/W	Defines whether the default signal value for X2 is defined.
401489	1488	0x05D0	2	Input #2 Signal Default Value	Float	0	Any value	N/A	R/W	X2 default value, if Input #2 Signal Default is Yes.
401491	1490	0x05D2	1	Unary Function #2	Byte	0 - Undefined	See Table 19. Unary Functions	N/A	R/W	f2(x) – Unary function #2
401492	1491	0x05D3	2	Scale #2	Float	1	Any value	N/A	R/W	a2 – Scale #2
401494	1493	0x05D5	2	Offset #2	Float	0	Any value	N/A	R/W	b2 – Offset #2

Bit/Reg Address	Modbus Address		# of Reg	Name	Format	Default	Range	Units or Res.	Access	Description
	Dec	Hex								
401496	1495	0x05D7	9	Reserved	N/A	N/A	N/A	N/A	RO	Reserved for future use. Reading results in 0. Writing is allowed but does not change the value.
Binary Function #6										
401505	1504	0x05E0	1	Binary Function	Byte	0 - Undefined	See Table 20. Binary Functions	N/A	R/W	F[x;y] – Binary function
401506	1505	0x05E1	2	Output Scale	Float	1	Any value	N/A	R/W	A – Output Scale
401508	1507	0x05E3	2	Output Offset	Float	0	Any value	N/A	R/W	B – Output Offset
401510	1509	0x05E5	1	Input #1 Signal Source	Byte	0 - Not Connected	Any signal output of any function block or "Not connected". See Table 6. Controller Signal Sources	N/A	R/W	X1 – Input Signal #1
401511	1510	0x05E6	1	Input #1 Signal Default	Byte	0 - No	0 - No, 1 - Yes	N/A	R/W	Defines whether the default signal value for X1 is defined.
401512	1511	0x05E7	2	Input #1 Signal Default Value	Float	0	Any value	N/A	R/W	X1 default value, if Input #1 Signal Default is "Yes".
401514	1513	0x05E9	1	Unary Function #1	Byte	0 - Undefined	See Table 19. Unary Functions	N/A	R/W	f1(x) – Unary function #1
401515	1514	0x05EA	2	Scale #1	Float	1	Any value	N/A	R/W	a1 – Scale #1
401517	1516	0x05EC	2	Offset #1	Float	0	Any value	N/A	R/W	b1 – Offset #1
401519	1518	0x05EE	1	Input #2 Signal Source	Byte	0 - Not Connected	Any signal output of any function block or "Not connected". See Table 6. Controller Signal Sources	N/A	R/W	X2 – Input Signal #2
401520	1519	0x05EF	1	Input #2 Signal Default	Byte	0 - No	0 - No, 1 - Yes	N/A	R/W	Defines whether the default signal value for X2 is defined.

Bit/Reg Address	Modbus Address		# of Reg	Name	Format	Default	Range	Units or Res.	Access	Description
	Dec	Hex								
401521	1520	0x05F0	2	Input #2 Signal Default Value	Float	0	Any value	N/A	R/W	X2 default value, if Input #2 Signal Default is Yes.
401523	1522	0x05F2	1	Unary Function #2	Byte	0 - Undefined	See Table 19. Unary Functions	N/A	R/W	f2(x) – Unary function #2
401524	1523	0x05F3	2	Scale #2	Float	1	Any value	N/A	R/W	a2 – Scale #2
401526	1525	0x05F5	2	Offset #2	Float	0	Any value	N/A	R/W	b2 – Offset #2
401528	1527	0x05F7	9	Reserved	N/A	N/A	N/A	N/A	RO	Reserved for future use. Reading results in 0. Writing is allowed but does not change the value.

Binary Function #7

401537	1536	0x0600	1	Binary Function	Byte	0 - Undefined	See Table 20. Binary Functions	N/A	R/W	F[x;y] – Binary function
401538	1537	0x0601	2	Output Scale	Float	1	Any value	N/A	R/W	A – Output Scale
401540	1539	0x0603	2	Output Offset	Float	0	Any value	N/A	R/W	B – Output Offset
401542	1541	0x0605	1	Input #1 Signal Source	Byte	0 - Not Connected	Any signal output of any function block or "Not connected". See Table 6. Controller Signal Sources	N/A	R/W	X1 – Input Signal #1
401543	1542	0x0606	1	Input #1 Signal Default	Byte	0 - No	0 - No, 1 - Yes	N/A	R/W	Defines whether the default signal value for X1 is defined.
401544	1543	0x0607	2	Input #1 Signal Default Value	Float	0	Any value	N/A	R/W	X1 default value, if Input #1 Signal Default is "Yes".
401546	1545	0x0609	1	Unary Function #1	Byte	0 - Undefined	See Table 19. Unary Functions	N/A	R/W	f1(x) – Unary function #1
401547	1546	0x060A	2	Scale #1	Float	1	Any value	N/A	R/W	a1 – Scale #1
401549	1548	0x060C	2	Offset #1	Float	0	Any value	N/A	R/W	b1 – Offset #1
401551	1550	0x060E	1	Input #2 Signal Source	Byte	0 - Not Connected	Any signal output of any function block or "Not connected". See Table 6.	N/A	R/W	X2 – Input Signal #2

Bit/Reg Address	Modbus Address		# of Reg	Name	Format	Default	Range	Units or Res.	Access	Description
	Dec	Hex								
							Controller Signal Sources			
401552	1551	0x060F	1	Input #2 Signal Default	Byte	0 - No	0 - No, 1 - Yes	N/A	R/W	Defines whether the default signal value for X2 is defined.
401553	1552	0x0610	2	Input #2 Signal Default Value	Float	0	Any value	N/A	R/W	X2 default value, if Input #2 Signal Default is Yes.
401555	1554	0x0612	1	Unary Function #2	Byte	0 - Undefined	See Table 19. Unary Functions	N/A	R/W	f2(x) – Unary function #2
401556	1555	0x0613	2	Scale #2	Float	1	Any value	N/A	R/W	a2 – Scale #2
401558	1557	0x0615	2	Offset #2	Float	0	Any value	N/A	R/W	b2 – Offset #2
401560	1559	0x0617	9	Reserved	N/A	N/A	N/A	N/A	RO	Reserved for future use. Reading results in 0. Writing is allowed but does not change the value.
Binary Function #8										
401569	1568	0x0620	1	Binary Function	Byte	0 - Undefined	See Table 20. Binary Functions	N/A	R/W	F[x;y] – Binary function
401570	1569	0x0621	2	Output Scale	Float	1	Any value	N/A	R/W	A – Output Scale
401572	1571	0x0623	2	Output Offset	Float	0	Any value	N/A	R/W	B – Output Offset
401574	1573	0x0625	1	Input #1 Signal Source	Byte	0 - Not Connected	Any signal output of any function block or "Not connected". See Table 6. Controller Signal Sources	N/A	R/W	X1 – Input Signal #1
401575	1574	0x0626	1	Input #1 Signal Default	Byte	0 - No	0 - No, 1 - Yes	N/A	R/W	Defines whether the default signal value for X1 is defined.
401576	1575	0x0627	2	Input #1 Signal Default Value	Float	0	Any value	N/A	R/W	X1 default value, if Input #1 Signal Default is "Yes".
401578	1577	0x0629	1	Unary Function #1	Byte	0 - Undefined	See Table 19. Unary Functions	N/A	R/W	f1(x) – Unary function #1
401579	1578	0x062A	2	Scale #1	Float	1	Any value	N/A	R/W	a1 – Scale #1
401581	1580	0x062C	2	Offset #1	Float	0	Any value	N/A	R/W	b1 – Offset #1

Bit/Reg Address	Modbus Address		# of Reg	Name	Format	Default	Range	Units or Res.	Access	Description
	Dec	Hex								
401583	1582	0x062E	1	Input #2 Signal Source	Byte	0 - Not Connected	Any signal output of any function block or "Not connected". See Table 6. Controller Signal Sources	N/A	R/W	X2 – Input Signal #2
401584	1583	0x062F	1	Input #2 Signal Default	Byte	0 - No	0 - No, 1 - Yes	N/A	R/W	Defines whether the default signal value for X2 is defined.
401585	1584	0x0630	2	Input #2 Signal Default Value	Float	0	Any value	N/A	R/W	X2 default value, if Input #2 Signal Default is Yes.
401587	1586	0x0632	1	Unary Function #2	Byte	0 - Undefined	See Table 19. Unary Functions	N/A	R/W	f2(x) – Unary function #2
401588	1587	0x0633	2	Scale #2	Float	1	Any value	N/A	R/W	a2 – Scale #2
401590	1589	0x0635	2	Offset #2	Float	0	Any value	N/A	R/W	b2 – Offset #2
401592	1591	0x0637	9	Reserved	N/A	N/A	N/A	N/A	RO	Reserved for future use. Reading results in 0. Writing is allowed but does not change the value.
Binary Function #9										
401601	1600	0x0640	1	Binary Function	Byte	0 - Undefined	See Table 20. Binary Functions	N/A	R/W	F[x;y] – Binary function
401602	1601	0x0641	2	Output Scale	Float	1	Any value	N/A	R/W	A – Output Scale
401604	1603	0x0643	2	Output Offset	Float	0	Any value	N/A	R/W	B – Output Offset
401606	1605	0x0645	1	Input #1 Signal Source	Byte	0 - Not Connected	Any signal output of any function block or "Not connected". See Table 6. Controller Signal Sources	N/A	R/W	X1 – Input Signal #1
401607	1606	0x0646	1	Input #1 Signal Default	Byte	0 - No	0 - No, 1 - Yes	N/A	R/W	Defines whether the default signal value for X1 is defined.

Bit/Reg Address	Modbus Address		# of Reg	Name	Format	Default	Range	Units or Res.	Access	Description
	Dec	Hex								
401608	1607	0x0647	2	Input #1 Signal Default Value	Float	0	Any value	N/A	R/W	X1 default value, if Input #1 Signal Default is "Yes".
401610	1609	0x0649	1	Unary Function #1	Byte	0 - Undefined	See Table 19. Unary Functions	N/A	R/W	f1(x) – Unary function #1
401611	1610	0x064A	2	Scale #1	Float	1	Any value	N/A	R/W	a1 – Scale #1
401613	1612	0x064C	2	Offset #1	Float	0	Any value	N/A	R/W	b1 – Offset #1
401615	1614	0x064E	1	Input #2 Signal Source	Byte	0 - Not Connected	Any signal output of any function block or "Not connected". See Table 6. Controller Signal Sources	N/A	R/W	X2 – Input Signal #2
401616	1615	0x064F	1	Input #2 Signal Default	Byte	0 - No	0 - No, 1 - Yes	N/A	R/W	Defines whether the default signal value for X2 is defined.
401617	1616	0x0650	2	Input #2 Signal Default Value	Float	0	Any value	N/A	R/W	X2 default value, if Input #2 Signal Default is Yes.
401619	1618	0x0652	1	Unary Function #2	Byte	0 - Undefined	See Table 19. Unary Functions	N/A	R/W	f2(x) – Unary function #2
401620	1619	0x0653	2	Scale #2	Float	1	Any value	N/A	R/W	a2 – Scale #2
401622	1621	0x0655	2	Offset #2	Float	0	Any value	N/A	R/W	b2 – Offset #2
401624	1623	0x0657	9	Reserved	N/A	N/A	N/A	N/A	RO	Reserved for future use. Reading results in 0. Writing is allowed but does not change the value.
Binary Function #10										
401633	1632	0x0660	1	Binary Function	Byte	0 - Undefined	See Table 20. Binary Functions	N/A	R/W	F[x;y] – Binary function
401634	1633	0x0661	2	Output Scale	Float	1	Any value	N/A	R/W	A – Output Scale
401636	1635	0x0663	2	Output Offset	Float	0	Any value	N/A	R/W	B – Output Offset
401638	1637	0x0665	1	Input #1 Signal Source	Byte	0 - Not Connected	Any signal output of any function block or "Not connected". See Table 6.	N/A	R/W	X1 – Input Signal #1

Bit/Reg Address	Modbus Address		# of Reg	Name	Format	Default	Range	Units or Res.	Access	Description
	Dec	Hex								
							Controller Signal Sources			
401639	1638	0x0666	1	Input #1 Signal Default	Byte	0 - No	0 - No, 1 - Yes	N/A	R/W	Defines whether the default signal value for X1 is defined.
401640	1639	0x0667	2	Input #1 Signal Default Value	Float	0	Any value	N/A	R/W	X1 default value, if Input #1 Signal Default is "Yes".
401642	1641	0x0669	1	Unary Function #1	Byte	0 - Undefined	See Table 19. Unary Functions	N/A	R/W	f1(x) – Unary function #1
401643	1642	0x066A	2	Scale #1	Float	1	Any value	N/A	R/W	a1 – Scale #1
401645	1644	0x066C	2	Offset #1	Float	0	Any value	N/A	R/W	b1 – Offset #1
401647	1646	0x066E	1	Input #2 Signal Source	Byte	0 - Not Connected	Any signal output of any function block or "Not connected". See Table 6. Controller Signal Sources	N/A	R/W	X2 – Input Signal #2
401648	1647	0x066F	1	Input #2 Signal Default	Byte	0 - No	0 - No, 1 - Yes	N/A	R/W	Defines whether the default signal value for X2 is defined.
401649	1648	0x0670	2	Input #2 Signal Default Value	Float	0	Any value	N/A	R/W	X2 default value, if Input #2 Signal Default is Yes.
401651	1650	0x0672	1	Unary Function #2	Byte	0 - Undefined	See Table 19. Unary Functions	N/A	R/W	f2(x) – Unary function #2
401652	1651	0x0673	2	Scale #2	Float	1	Any value	N/A	R/W	a2 – Scale #2
401654	1653	0x0675	2	Offset #2	Float	0	Any value	N/A	R/W	b2 – Offset #2
401656	1655	0x0677	9	Reserved	N/A	N/A	N/A	N/A	RO	Reserved for future use. Reading results in 0. Writing is allowed but does not change the value.
Global Parameters										
401665	1664	0x0680	2	Global Continuous Constant Signal	Float	0	Any value	N/A	R/W	Output signal value of the Global Continuous Constant Signal

Bit/Reg Address	Modbus Address		# of Reg	Name	Format	Default	Range	Units or Res.	Access	Description
	Dec	Hex								
401667	1666	0x0682	2	Global Discrete Constant Signal	DWord	0	Any value [0...4294967295 (0xFFFFFFFF)]	N/A	R/W	Output signal value of the Global Discrete Constant Signal
401669	1668	0x0684	12	Reserved	N/A	N/A	N/A	N/A	RO	Reserved for future use. Reading results in 0. Writing is allowed but does not change the value.
CANopen Network										
401682	1681	0x0691	1	Node ID	Byte	127	0...127	N/A	R/W	CANopen ECU address
401683	1682	0x0692	1	Baud Rate	Word	125	{10,20,50, 125, 250, 500, 800, 1000}	kbit/s	RO	Current baud rate on the CAN network. Writing is allowed but does not change the value.
401684	1683	0x0693	1	Slew Rate	Byte	0 - Low	0 - Low, 1 - High	N/A	R/W	Slew rate control of the CAN transceiver
401685	1684	0x0694	11	Reserved	N/A	N/A	N/A	N/A	RO	Reserved for future use. Reading results in 0. Writing is allowed but does not change the value.
Ethernet										
401697	1696	0x06A0	3	MAC Address	Byte[6]	Set at the factory	Any valid MAC address	N/A	RO	Ethernet MAC Address. Set at the factory. Writing is allowed but does not change the value.
401700	1699	0x06A3	2	IP Address	Byte[4]	192.168.0.34	Any IP address	N/A	R/W	The device IP address
401702	1701	0x06A5	2	Subnet Mask	Byte[4]	255.255.255.0	Any IP address	N/A	R/W	The device subnet mask
401704	1703	0x06A7	2	Gateway	Byte[4]	192.168.0.1	Any IP address	N/A	R/W	The device default gateway
401706	1705	0x06A9	1	Modbus Port	Word	502	Any port value except the Discovery Port (35100)	N/A	R/W	The Modbus listening port
401707	1706	0x06AA	1	Modbus Timeout	Word	1000	1...10000	ms	R/W	The Modbus communication timeout

Bit/Reg Address	Modbus Address		# of Reg	Name	Format	Default	Range	Units or Res.	Access	Description
	Dec	Hex								
401708	1707	0x06AB	21	Reserved	N/A	N/A	N/A	N/A	RO	Reserved for future use. Reading results in 0. Writing is allowed but does not change the value.
CAN Input Signal #1										
401729	1728	0x06C0	1	Signal Type	Byte	255	255	N/A	RO	CAN input signal type
401730	1729	0x06C1	1	COB ID	Word	27F	Up to 7FF	N/A	R/W	Signal message ID value
401731	1730	0x06C2	1	Autoreset time	Word	0	65535	N/A	R/W	There will not be an autoreset if the value is set to 0
401732	1731	0x06C3	1	Signal source#1	Word	0	0xFFFFh	N/A	R/W	Source of the output for first 2 bytes. Can be any mappable object. See Sections 4,5, and 6
401733	1732	0x06C4	1	Signal number#1	Byte	0	0..255	N/A	R/W	Defines a subindex of a chosen object.
401734	1733	0x06C5	1	Signal resolution#1	Byte	0	0...3	N/A	R/W	Shows the number of decimal digits
401735	1734	0x06C6	1	Signal offset#1	Word	0	0...65535	N/A	R/W	Defines the offset for the signal
401736	1735	0x06C7	1	Signal data size#1	Byte	0	0, 8, 16, 24, 32	N/A	R/W	Defines the number of bits. Can only be equal to 0,1,2,3 and 4 bytes
401737	1736	0x06C8	1	Control source#2	Word	0	0xFFFFh	N/A	R/W	Source of the output for second 2 bytes. Can be any mappable object. See Sections 4,5, and 6
401738	1737	0x06C9	1	Control number#2	Byte	0	0..255	N/A	R/W	CAN input signal size
401739	1738	0x06CA	1	Signal resolution#2	Byte	0	0...3	N/A	R/W	Shows the number of decimal digits
401740	1739	0x06CB	1	Signal offset#2	Word	0	0...65535	N/A	R/W	Defines the offset for the signal
401741	1740	0x06CC	1	Signal data size#2	Byte	0	0, 8, 16, 24, 32	N/A	R/W	Defines the number of bits. Can only be equal to 0,1,2,3 and 4 bytes
401742	1741	0x06CD	1	Control source#3	Word	0	0xFFFFh	N/A	R/W	Source of the output for third 2 bytes. Can be

Bit/Reg Address	Modbus Address		# of Reg	Name	Format	Default	Range	Units or Res.	Access	Description
	Dec	Hex								
										any mappable object. See Sections 4,5, and 6
401743	1742	0x06CE	1	Control number#3	Byte	0	0..255	N/A	R/W	CAN input signal offset for continuous input signals.
401744	1743	0x06CF	1	Signal resolution#3	Byte	0	0...3	N/A	R/W	Shows the number of decimal digits
401745	1744	0x06D0	1	Signal offset#3	Word	0	0...65535	N/A	R/W	Defines the offset for the signal
401746	1745	0x06D1	1	Signal data size#3	Byte	0	0, 8, 16, 24, 32	N/A	R/W	Defines the number of bits. Can only be equal to 0,1,2,3 and 4 bytes
401747	1746	0x06D2	1	Control source#4	Word	0	0xFFFFh	N/A	R/W	Source of the output for last 2 bytes. Can be any mappable object. See Sections 4,5, and 6
401748	1747	0x06D3	1	Control number#4	Byte	0	0..255	N/A	R/W	CAN input signal offset for continuous input signals.
401749	1748	0x06D4	1	Signal resolution#4	Byte	0	0...3	N/A	R/W	Shows the number of decimal digits
401750	1749	0x06D5	1	Signal offset#4	Word	0	0...65535	N/A	R/W	Defines the offset for the signal
401751	1750	0x06D6	1	Signal data size#4	Byte	0	0, 8, 16, 24, 32	N/A	R/W	Defines the number of bits. Can only be equal to 0,1,2,3 and 4 bytes
401752	1751	0x06D7	1	Control source#5	Word	0	0xFFFFh	N/A	R/W	Source of the output for last 2 bytes. Can be any mappable object. See Sections 4,5, and 6
401753	1752	0x06D8	1	Control number#5	Byte	0	0..255	N/A	R/W	CAN input signal offset for continuous input signals.
401754	1753	0x06D9	1	Signal resolution#5	Byte	0	0...3	N/A	R/W	Shows the number of decimal digits
401755	1754	0x06DA	1	Signal offset#5	Word	0	0...65535	N/A	R/W	Defines the offset for the signal

Bit/Reg Address	Modbus Address		# of Reg	Name	Format	Default	Range	Units or Res.	Access	Description
	Dec	Hex								
401756	1755	0x06DB	1	Signal data size#5	Byte	0	0, 8, 16, 24, 32	N/A	R/W	Defines the number of bits. Can only be equal to 0,1,2,3 and 4 bytes
401757	1756	0x06DC	1	Control source#6	Word	0	0xFFFFh	N/A	R/W	Source of the output for last 2 bytes. Can be any mappable object. See Sections 4,5, and 6
401758	1757	0x06DD	1	Control number#6	Byte	0	0..255	N/A	R/W	CAN input signal offset for continuous input signals.
401759	1758	0x06DE	1	Signal resolution#6	Byte	0	0..3	N/A	R/W	Shows the number of decimal digits
401760	1759	0x06DF	1	Signal offset#6	Word	0	0..65535	N/A	R/W	Defines the offset for the signal
401761	1760	0x06E0	1	Signal data size#6	Byte	0	0, 8, 16, 24, 32	N/A	R/W	Defines the number of bits. Can only be equal to 0,1,2,3 and 4 bytes
401762	1761	0x06E1	1	Control source#7	Word	0	0xFFFFh	N/A	R/W	Source of the output for last 2 bytes. Can be any mappable object. See Sections 4,5, and 6
401763	1762	0x06E2	1	Control number#7	Byte	0	0..255	N/A	R/W	CAN input signal offset for continuous input signals.
401764	1763	0x06E3	1	Signal resolution#7	Byte	0	0..3	N/A	R/W	Shows the number of decimal digits
401765	1764	0x06E4	1	Signal offset#7	Word	0	0..65535	N/A	R/W	Defines the offset for the signal
401766	1765	0x06E5	1	Signal data size#7	Byte	0	0, 8, 16, 24, 32	N/A	R/W	Defines the number of bits. Can only be equal to 0,1,2,3 and 4 bytes
401767	1766	0x06E6	1	Control source#8	Word	0	0xFFFFh	N/A	R/W	Source of the output for last 2 bytes. Can be any mappable object. See Sections 4,5, and 6
401768	1767	0x06E7	1	Control number#8	Byte	0	0..255	N/A	R/W	CAN input signal offset for continuous input signals.

Bit/Reg Address	Modbus Address		# of Reg	Name	Format	Default	Range	Units or Res.	Access	Description
	Dec	Hex								
401769	1768	0x06E8	1	Signal resolution#8	Byte	0	0...3	N/A	R/W	Shows the number of decimal digits
401770	1769	0x06E9	1	Signal offset#8	Word	0	0...65535	N/A	R/W	Defines the offset for the signal
401771	1770	0x06EA	1	Signal data size#8	Byte	0	0, 8, 16, 24, 32	N/A	R/W	Defines the number of bits. Can only be equal to 0,1,2,3 and 4 bytes
401772	1771	0x06EB	5	Reserved	N/A	N/A	N/A	N/A	RO	Reserved for future use. Reading results in 0. Writing is allowed but does not change the value.
CAN Input Signal #2										
401777	1776	0x06F0	1	Signal Type	Byte	255	255	N/A	RO	CAN input signal type
401778	1777	0x06F1	1	COB ID	Byte	37F	Up to 7FF	N/A	R/W	Signal message ID value
401779	1778	0x06F2	1	Autoreset time	Word	0	65535	N/A	R/W	There will not be an autoreset if the value is set to 0
401780	1779	0x06F3	1	Control source#1	Word	0	0xFFFFh	N/A	R/W	Source of the output for first 2 bytes. Can be any mappable object. See Sections 4,5, and 6
401781	1780	0x06F4	1	Control number#1	Byte	0	0..255	N/A	R/W	Defines a subindex of a chosen object.
401782	1781	0x06F5	1	Signal resolution#1	Byte	0	0...3	N/A	R/W	Shows the number of decimal digits
401783	1782	0x06F6	1	Signal offset#1	Word	0	0...65535	N/A	R/W	Defines the offset for the signal
401784	1783	0x06F7	1	Signal data size#1	Byte	0	0, 8, 16, 24, 32	N/A	R/W	Defines the number of bits. Can only be equal to 0,1,2,3 and 4 bytes
401785	1784	0x06F8	1	Control source#2	Word	0	0xFFFFh	N/A	R/W	Source of the output for second 2 bytes. Can be any mappable object. See Sections 4,5, and 6
401786	1785	0x06F9	1	Control number#2	Byte	0	0..255	N/A	R/W	CAN input signal size
401787	1786	0x06FA	1	Signal resolution#2	Byte	0	0...3	N/A	R/W	Shows the number of decimal digits

Bit/Reg Address	Modbus Address		# of Reg	Name	Format	Default	Range	Units or Res.	Access	Description
	Dec	Hex								
401788	1787	0x06FB	1	Signal offset#2	Word	0	0...65535	N/A	R/W	Defines the offset for the signal
401789	1788	0x06FC	1	Signal data size#2	Byte	0	0, 8, 16, 24, 32	N/A	R/W	Defines the number of bits. Can only be equal to 0,1,2,3 and 4 bytes
401790	1789	0x06FD	1	Control source#3	Word	0	0xFFFFh	N/A	R/W	Source of the output for third 2 bytes. Can be any mappable object. See Sections 4,5, and 6
401791	1790	0x06FE	1	Control number#3	Byte	0	0..255	N/A	R/W	CAN input signal offset for continuous input signals.
401792	1791	0x06FF	1	Signal resolution#3	Byte	0	0...3	N/A	R/W	Shows the number of decimal digits
401793	1792	0x0700	1	Signal offset#3	Word	0	0...65535	N/A	R/W	Defines the offset for the signal
401794	1793	0x0700	1	Signal data size#3	Byte	0	0, 8, 16, 24, 32	N/A	R/W	Defines the number of bits. Can only be equal to 0,1,2,3 and 4 bytes
401795	1794	0x0701	1	Control source#4	Word	0	0xFFFFh	N/A	R/W	Source of the output for last 2 bytes. Can be any mappable object. See Sections 4,5, and 6
401796	1795	0x0702	1	Control number#4	Byte	0	0..255	N/A	R/W	CAN input signal offset for continuous input signals.
401797	1796	0x0703	1	Signal resolution#4	Byte	0	0...3	N/A	R/W	Shows the number of decimal digits
401798	1797	0x0704	1	Signal offset#4	Word	0	0...65535	N/A	R/W	Defines the offset for the signal
401799	1798	0x0705	1	Signal data size#4	Byte	0	0, 8, 16, 24, 32	N/A	R/W	Defines the number of bits. Can only be equal to 0,1,2,3 and 4 bytes
401800	1799	0x0706	1	Control source#5	Word	0	0xFFFFh	N/A	R/W	Source of the output for last 2 bytes. Can be any mappable object. See Sections 4,5, and 6

Bit/Reg Address	Modbus Address		# of Reg	Name	Format	Default	Range	Units or Res.	Access	Description
	Dec	Hex								
401801	1800	0x0707	1	Control number#5	Byte	0	0..255	N/A	R/W	CAN input signal offset for continuous input signals.
401802	1801	0x0708	1	Signal resolution#5	Byte	0	0...3	N/A	R/W	Shows the number of decimal digits
401803	1802	0x0709	1	Signal offset#5	Word	0	0...65535	N/A	R/W	Defines the offset for the signal
401804	1803	0x070A	1	Signal data size#5	Byte	0	0, 8, 16, 24, 32	N/A	R/W	Defines the number of bits. Can only be equal to 0,1,2,3 and 4 bytes
401805	1804	0x070B	1	Control source#6	Word	0	0xFFFFh	N/A	R/W	Source of the output for last 2 bytes. Can be any mappable object. See Sections 4,5, and 6
401806	1805	0x070C	1	Control number#6	Byte	0	0..255	N/A	R/W	CAN input signal offset for continuous input signals.
401807	1806	0x070D	1	Signal resolution#6	Byte	0	0...3	N/A	R/W	Shows the number of decimal digits
401808	1807	0x070E	1	Signal offset#6	Word	0	0...65535	N/A	R/W	Defines the offset for the signal
401809	1808	0x070F	1	Signal data size#6	Byte	0	0, 8, 16, 24, 32	N/A	R/W	Defines the number of bits. Can only be equal to 0,1,2,3 and 4 bytes
401810	1809	0x0710	1	Control source#7	Word	0	0xFFFFh	N/A	R/W	Source of the output for last 2 bytes. Can be any mappable object. See Sections 4,5, and 6
401811	1810	0x0711	1	Control number#7	Byte	0	0..255	N/A	R/W	CAN input signal offset for continuous input signals.
401812	1811	0x0712	1	Signal resolution#7	Byte	0	0...3	N/A	R/W	Shows the number of decimal digits
401813	1812	0x0713	1	Signal offset#7	Word	0	0...65535	N/A	R/W	Defines the offset for the signal
401814	1813	0x0714	1	Signal data size#7	Byte	0	0, 8, 16, 24, 32	N/A	R/W	Defines the number of bits. Can only be equal to 0,1,2,3 and 4 bytes

Bit/Reg Address	Modbus Address		# of Reg	Name	Format	Default	Range	Units or Res.	Access	Description
	Dec	Hex								
401815	1814	0x0715	1	Control source#8	Word	0	0xFFFFh	N/A	R/W	Source of the output for last 2 bytes. Can be any mappable object. See Sections 4,5, and 6
401816	1815	0x0716	1	Control number#8	Byte	0	0..255	N/A	R/W	CAN input signal offset for continuous input signals.
401817	1816	0x0717	1	Signal resolution#8	Byte	0	0...3	N/A	R/W	Shows the number of decimal digits
401818	1817	0x0718	1	Signal offset#8	Word	0	0...65535	N/A	R/W	Defines the offset for the signal
401819	1818	0x0719	1	Signal data size#8	Byte	0	0, 8, 16, 24, 32	N/A	R/W	Defines the number of bits. Can only be equal to 0,1,2,3 and 4 bytes
401820	1819	0x071A	5	Reserved	N/A	N/A	N/A	N/A	RO	Reserved for future use. Reading results in 0. Writing is allowed but does not change the value.
CAN Input Signal #3										
401825	1824	0x0721	1	Signal Type	Byte	255	255	N/A	RO	CAN input signal type
401826	1825	0x0722	1	COB ID	Byte	47F	Up to 7FF	N/A	R/W	Signal message ID value
401827	1826	0x0723	1	Autoreset time	Word	0	65535	N/A	R/W	There will not be an autoreset if the value is set to 0
401828	1827	0x0724	1	Control source#1	Word	0	0xFFFFh	N/A	R/W	Source of the output for first 2 bytes. Can be any mappable object. See Sections 4,5, and 6
401829	1828	0x0725	1	Control number#1	Byte	0	0..255	N/A	R/W	Defines a subindex of a chosen object.
401830	1829	0x0726	1	Signal resolution#1	Byte	0	0...3	N/A	R/W	Shows the number of decimal digits
401831	1830	0x0727	1	Signal offset#1	Word	0	0...65535	N/A	R/W	Defines the offset for the signal
401832	1831	0x0728	1	Signal data size#1	Byte	0	0, 8, 16, 24, 32	N/A	R/W	Defines the number of bits. Can only be equal to 0,1,2,3 and 4 bytes

Bit/Reg Address	Modbus Address		# of Reg	Name	Format	Default	Range	Units or Res.	Access	Description
	Dec	Hex								
401833	1832	0x0729	1	Control source#2	Word	0	0xFFFFh	N/A	R/W	Source of the output for second 2 bytes. Can be any mappable object. See Sections 4,5, and 6
401834	1833	0x072A	1	Control number#2	Byte	0	0..255	N/A	R/W	CAN input signal size
401835	1834	0x072B	1	Signal resolution#2	Byte	0	0...3	N/A	R/W	Shows the number of decimal digits
401836	1835	0x072C	1	Signal offset#2	Word	0	0...65535	N/A	R/W	Defines the offset for the signal
401837	1836	0x072D	1	Signal data size#2	Byte	0	0, 8, 16, 24, 32	N/A	R/W	Defines the number of bits. Can only be equal to 0,1,2,3 and 4 bytes
401838	1837	0x072E	1	Control source#3	Word	0	0xFFFFh	N/A	R/W	Source of the output for third 2 bytes. Can be any mappable object. See Sections 4,5, and 6
401839	1838	0x072F	1	Control number#3	Byte	0	0..255	N/A	R/W	CAN input signal offset for continuous input signals.
401840	1839	0x0730	1	Signal resolution#3	Byte	0	0...3	N/A	R/W	Shows the number of decimal digits
401841	1840	0x0731	1	Signal offset#3	Word	0	0...65535	N/A	R/W	Defines the offset for the signal
401842	1841	0x0732	1	Signal data size#3	Byte	0	0, 8, 16, 24, 32	N/A	R/W	Defines the number of bits. Can only be equal to 0,1,2,3 and 4 bytes
401843	1842	0x0733	1	Control source#4	Word	0	0xFFFFh	N/A	R/W	Source of the output for last 2 bytes. Can be any mappable object. See Sections 4,5, and 6
401844	1843	0x0734	1	Control number#4	Byte	0	0..255	N/A	R/W	CAN input signal offset for continuous input signals.
401845	1844	0x0735	1	Signal resolution#4	Byte	0	0...3	N/A	R/W	Shows the number of decimal digits
401846	1845	0x0736	1	Signal offset#4	Word	0	0...65535	N/A	R/W	Defines the offset for the signal

Bit/Reg Address	Modbus Address		# of Reg	Name	Format	Default	Range	Units or Res.	Access	Description
	Dec	Hex								
401847	1846	0x0737	1	Signal data size#4	Byte	0	0, 8, 16, 24, 32	N/A	R/W	Defines the number of bits. Can only be equal to 0,1,2,3 and 4 bytes
401847	1847	0x0738	1	Control source#5	Word	0	0xFFFFh	N/A	R/W	Source of the output for last 2 bytes. Can be any mappable object. See Sections 4,5, and 6
401847	1848	0x0739	1	Control number#5	Byte	0	0..255	N/A	R/W	CAN input signal offset for continuous input signals.
401847	1849	0x073A	1	Signal resolution#5	Byte	0	0..3	N/A	R/W	Shows the number of decimal digits
401847	1845	0x073B	1	Signal offset#5	Word	0	0..65535	N/A	R/W	Defines the offset for the signal
401847	1845	0x073C	1	Signal data size#5	Byte	0	0, 8, 16, 24, 32	N/A	R/W	Defines the number of bits. Can only be equal to 0,1,2,3 and 4 bytes
401847	1845	0x073D	1	Control source#6	Word	0	0xFFFFh	N/A	R/W	Source of the output for last 2 bytes. Can be any mappable object. See Sections 4,5, and 6
401847	1845	0x073E	1	Control number#6	Byte	0	0..255	N/A	R/W	CAN input signal offset for continuous input signals.
401847	1845	0x073F	1	Signal resolution#6	Byte	0	0..3	N/A	R/W	Shows the number of decimal digits
401847	1845	0x0740	1	Signal offset#6	Word	0	0..65535	N/A	R/W	Defines the offset for the signal
401847	1845	0x0741	1	Signal data size#6	Byte	0	0, 8, 16, 24, 32	N/A	R/W	Defines the number of bits. Can only be equal to 0,1,2,3 and 4 bytes
401847	1845	0x0742	1	Control source#7	Word	0	0xFFFFh	N/A	R/W	Source of the output for last 2 bytes. Can be any mappable object. See Sections 4,5, and 6
401847	1845	0x0743	1	Control number#7	Byte	0	0..255	N/A	R/W	CAN input signal offset for continuous input signals.

Bit/Reg Address	Modbus Address		# of Reg	Name	Format	Default	Range	Units or Res.	Access	Description
	Dec	Hex								
401848	1846	0x0744	1	Signal resolution#7	Byte	0	0...3	N/A	R/W	Shows the number of decimal digits
401849	1847	0x0745	1	Signal offset#7	Word	0	0...65535	N/A	R/W	Defines the offset for the signal
401850	1848	0x0746	1	Signal data size#7	Byte	0	0, 8, 16, 24, 32	N/A	R/W	Defines the number of bits. Can only be equal to 0,1,2,3 and 4 bytes
401851	1849	0x0747	1	Control source#8	Word	0	0xFFFFh	N/A	R/W	Source of the output for last 2 bytes. Can be any mappable object. See Sections 4,5, and 6
401852	1850	0x0743	1	Control number#8	Byte	0	0..255	N/A	R/W	CAN input signal offset for continuous input signals.
401853	1851	0x0748	1	Signal resolution#8	Byte	0	0...3	N/A	R/W	Shows the number of decimal digits
401854	1852	0x0749	1	Signal offset#8	Word	0	0...65535	N/A	R/W	Defines the offset for the signal
401855	1853	0x04A	1	Signal data size#8	Byte	0	0, 8, 16, 24, 32	N/A	R/W	Defines the number of bits. Can only be equal to 0,1,2,3 and 4 bytes
401856	1854	0x074B	5	Reserved	N/A	N/A	N/A	N/A	RO	Reserved for future use. Reading results in 0. Writing is allowed but does not change the value.
CAN Output Message #1										
401873	1872	0x0751	1	COB ID	Word	1FF	Up to 7FF	N/A	R/W	CAN message 11 bit ID
401874	1873	0x0752	1	Transmission Enable	Byte	1 - No	1 - No, 0 - Yes	N/A	R/W	Transmission Enable. Enables the CAN output message transmission
401875	1874	0x0753	1	Transmission Rate	Word	100	0...10000	ms	R/W	CAN output message transmission rate. If 0 – transmission is upon request.
401876	1875	0x0754	1	Transmission type	Byte	254	254	N/A	RO	Type of a communication. 254 – asynchronous transmit

Bit/Reg Address	Modbus Address		# of Reg	Name	Format	Default	Range	Units or Res.	Access	Description
	Dec	Hex								
401877	1876	0x0755	1	Control source#1	Word	0	0xFFFFh	N/A	R/W	Source of the output for first 2 bytes. Can be any mappable object. See Sections 4,5, and 6
401878	1877	0x0756	1	Control number#1	Byte	0	0..255	N/A	R/W	Defines a subindex of a chosen object.
401879	1878	0x0757	1	Signal resolution#1	Byte	0	0...3	N/A	R/W	Shows the number of decimal digits
401880	1879	0x0758	1	Signal offset#1	Word	0	0...65535	N/A	R/W	Defines the offset for the signal
401881	1880	0x0759	1	Signal data size#1	Byte	0	0, 8, 16, 24, 32	N/A	R/W	Defines the number of bits. Can only be equal to 0,1,2,3 and 4 bytes
401882	1881	0x075A	1	Control source#2	Word	0	0xFFFFh	N/A	R/W	Source of the output for second 2 bytes. Can be any mappable object. See Sections 4,5, and 6
401883	1882	0x075B	1	Control number#2	Byte	0	0..255	N/A	R/W	CAN input signal size
401884	1883	0x075C	1	Signal resolution#2	Byte	0	0...3	N/A	R/W	Shows the number of decimal digits
401885	1884	0x075D	1	Signal offset#2	Word	0	0...65535	N/A	R/W	Defines the offset for the signal
401886	1885	0x075E	1	Signal data size#2	Byte	0	0, 8, 16, 24, 32	N/A	R/W	Defines the number of bits. Can only be equal to 0,1,2,3 and 4 bytes
401887	1886	0x075F	1	Control source#3	Word	0	0xFFFFh	N/A	R/W	Source of the output for third 2 bytes. Can be any mappable object. See Sections 4,5, and 6
401888	1887	0x0760	1	Control number#3	Byte	0	0..255	N/A	R/W	CAN input signal offset for continuous input signals.
401889	1888	0x0761	1	Signal resolution#3	Byte	0	0...3	N/A	R/W	Shows the number of decimal digits
401890	1889	0x0762	1	Signal offset#3	Word	0	0...65535	N/A	R/W	Defines the offset for the signal
401891	1890	0x0763	1	Signal data size#3	Byte	0	0, 8, 16, 24, 32	N/A	R/W	Defines the number of bits. Can only be equal to 0,1,2,3 and 4 bytes

Bit/Reg Address	Modbus Address		# of Reg	Name	Format	Default	Range	Units or Res.	Access	Description
	Dec	Hex								
401892	1891	0x0764	1	Control source#4	Word	0	0xFFFFh	N/A	R/W	Source of the output for last 2 bytes. Can be any mappable object. See Sections 4,5, and 6
401893	1892	0x0765	1	Control number#4	Byte	0	0..255	N/A	R/W	CAN input signal offset for continuous input signals.
401894	1893	0x0766	1	Signal resolution#4	Byte	0	0..3	N/A	R/W	Shows the number of decimal digits
401895	1894	0x0767	1	Signal offset#4	Word	0	0..65535	N/A	R/W	Defines the offset for the signal
401896	1895	0x0768	1	Signal data size#4	Byte	0	0, 8, 16, 24, 32	N/A	R/W	Defines the number of bits. Can only be equal to 0,1,2,3 and 4 bytes
401897	1896	0x0769	1	Control source#5	Word	0	0xFFFFh	N/A	R/W	Source of the output for last 2 bytes. Can be any mappable object. See Sections 4,5, and 6
401898	1897	0x076A	1	Control number#5	Byte	0	0..255	N/A	R/W	CAN input signal offset for continuous input signals.
401899	1898	0x076B	1	Signal resolution#5	Byte	0	0..3	N/A	R/W	Shows the number of decimal digits
401900	1899	0x076C	1	Signal offset#5	Word	0	0..65535	N/A	R/W	Defines the offset for the signal
401901	1900	0x076D	1	Signal data size#5	Byte	0	0, 8, 16, 24, 32	N/A	R/W	Defines the number of bits. Can only be equal to 0,1,2,3 and 4 bytes
401902	1901	0x076E	1	Control source#6	Word	0	0xFFFFh	N/A	R/W	Source of the output for last 2 bytes. Can be any mappable object. See Sections 4,5, and 6
401903	1902	0x076F	1	Control number#6	Byte	0	0..255	N/A	R/W	CAN input signal offset for continuous input signals.
401904	1903	0x0770	1	Signal resolution#6	Byte	0	0..3	N/A	R/W	Shows the number of decimal digits
401905	1904	0x0771	1	Signal offset#6	Word	0	0..65535	N/A	R/W	Defines the offset for the signal

Bit/Reg Address	Modbus Address		# of Reg	Name	Format	Default	Range	Units or Res.	Access	Description
	Dec	Hex								
401906	1905	0x0772	1	Signal data size#6	Byte	0	0, 8, 16, 24, 32	N/A	R/W	Defines the number of bits. Can only be equal to 0,1,2,3 and 4 bytes
401907	1906	0x0773	1	Control source#7	Word	0	0xFFFFh	N/A	R/W	Source of the output for last 2 bytes. Can be any mappable object. See Sections 4,5, and 6
401908	1907	0x0774	1	Control number#7	Byte	0	0..255	N/A	R/W	CAN input signal offset for continuous input signals.
401909	1908	0x0775	1	Signal resolution#7	Byte	0	0..3	N/A	R/W	Shows the number of decimal digits
401910	1909	0x0776	1	Signal offset#7	Word	0	0..65535	N/A	R/W	Defines the offset for the signal
401911	1910	0x0777	1	Signal data size#7	Byte	0	0, 8, 16, 24, 32	N/A	R/W	Defines the number of bits. Can only be equal to 0,1,2,3 and 4 bytes
401912	1911	0x0778	1	Control source#8	Word	0	0xFFFFh	N/A	R/W	Source of the output for last 2 bytes. Can be any mappable object. See Sections 4,5, and 6
401913	1912	0x0779	1	Control number#8	Byte	0	0..255	N/A	R/W	CAN input signal offset for continuous input signals.
401914	1913	0x077A	1	Signal resolution#8	Byte	0	0..3	N/A	R/W	Shows the number of decimal digits
401915	1914	0x077B	1	Signal offset#8	Word	0	0..65535	N/A	R/W	Defines the offset for the signal
401916	1915	0x077C	1	Signal data size#8	Byte	0	0, 8, 16, 24, 32	N/A	R/W	Defines the number of bits. Can only be equal to 0,1,2,3 and 4 bytes
401917	1916	0x075D	5	Reserved	N/A	N/A	N/A	N/A	RO	Reserved for future use. Reading results in 0. Writing is allowed but does not change the value.
CAN Output Message #2										
401921	1920	0x0780	1	COB ID	Word	1FF	Up to 7FF	N/A	R/W	CAN message 11 bit ID

Bit/Reg Address	Modbus Address		# of Reg	Name	Format	Default	Range	Units or Res.	Access	Description
	Dec	Hex								
401922	1921	0x0781	1	Transmission Enable	Byte	1 - No	1 - No, 0 - Yes	N/A	R/W	Transmission Enable. Enables the CAN output message transmission
401923	1922	0x0782	1	Transmission Rate	Word	100	0...10000	ms	R/W	CAN output message transmission rate. If 0 – transmission is upon request.
401924	1923	0x0783	1	Transmission type	Byte	254	254	N/A	RO	Type of a communication. 254 – asynchronous transmit
401925	1924	0x0784	1	Control source#1	Word	0	0xFFFFh	N/A	R/W	Source of the output for first 2 bytes. Can be any mappable object. See Sections 4,5, and 6
401926	1925	0x0785	1	Control number#1	Byte	0	0..255	N/A	R/W	Defines a subindex of a chosen object.
401927	1926	0x0786	1	Signal resolution#1	Byte	0	0...3	N/A	R/W	Shows the number of decimal digits
401928	1927	0x0787	1	Signal offset#1	Word	0	0...65535	N/A	R/W	Defines the offset for the signal
401929	1928	0x0788	1	Signal data size#1	Byte	0	0, 8, 16, 24, 32	N/A	R/W	Defines the number of bits. Can only be equal to 0,1,2,3 and 4 bytes
401930	1929	0x0789	1	Control source#2	Word	0	0xFFFFh	N/A	R/W	Source of the output for second 2 bytes. Can be any mappable object. See Sections 4,5, and 6
401931	1930	0x078A	1	Control number#2	Byte	0	0..255	N/A	R/W	CAN input signal size
401932	1931	0x078B	1	Signal resolution#2	Byte	0	0...3	N/A	R/W	Shows the number of decimal digits
401933	1932	0x078C	1	Signal offset#2	Word	0	0...65535	N/A	R/W	Defines the offset for the signal
401934	1933	0x078D	1	Signal data size#2	Byte	0	0, 8, 16, 24, 32	N/A	R/W	Defines the number of bits. Can only be equal to 0,1,2,3 and 4 bytes
401935	1934	0x078E	1	Control source#3	Word	0	0xFFFFh	N/A	R/W	Source of the output for third 2 bytes. Can be

Bit/Reg Address	Modbus Address		# of Reg	Name	Format	Default	Range	Units or Res.	Access	Description
	Dec	Hex								
										any mappable object. See Sections 4,5, and 6
401936	1935	0x078F	1	Control number#3	Byte	0	0..255	N/A	R/W	CAN input signal offset for continuous input signals.
401937	1936	0x0791	1	Signal resolution#3	Byte	0	0...3	N/A	R/W	Shows the number of decimal digits
401938	1937	0x0792	1	Signal offset#3	Word	0	0...65535	N/A	R/W	Defines the offset for the signal
401939	1938	0x0792	1	Signal data size#3	Byte	0	0, 8, 16, 24, 32	N/A	R/W	Defines the number of bits. Can only be equal to 0,1,2,3 and 4 bytes
401940	1939	0x0794	1	Control source#4	Word	0	0xFFFFh	N/A	R/W	Source of the output for last 2 bytes. Can be any mappable object. See Sections 4,5, and 6
401941	1940	0x0795	1	Control number#4	Byte	0	0..255	N/A	R/W	CAN input signal offset for continuous input signals.
401942	1941	0x0796	1	Signal resolution#4	Byte	0	0...3	N/A	R/W	Shows the number of decimal digits
401943	1942	0x0797	1	Signal offset#4	Word	0	0...65535	N/A	R/W	Defines the offset for the signal
401944	1943	0x0798	1	Signal data size#4	Byte	0	0, 8, 16, 24, 32	N/A	R/W	Defines the number of bits. Can only be equal to 0,1,2,3 and 4 bytes
401945	1944	0x0799	1	Control source#5	Word	0	0xFFFFh	N/A	R/W	Source of the output for last 2 bytes. Can be any mappable object. See Sections 4,5, and 6
401946	1945	0x079A	1	Control number#5	Byte	0	0..255	N/A	R/W	CAN input signal offset for continuous input signals.
401947	1946	0x079B	1	Signal resolution#5	Byte	0	0...3	N/A	R/W	Shows the number of decimal digits
401948	1947	0x079C	1	Signal offset#5	Word	0	0...65535	N/A	R/W	Defines the offset for the signal

Bit/Reg Address	Modbus Address		# of Reg	Name	Format	Default	Range	Units or Res.	Access	Description
	Dec	Hex								
401949	1948	0x079D	1	Signal data size#5	Byte	0	0, 8, 16, 24, 32	N/A	R/W	Defines the number of bits. Can only be equal to 0,1,2,3 and 4 bytes
401950	1949	0x079E	1	Control source#6	Word	0	0xFFFFh	N/A	R/W	Source of the output for last 2 bytes. Can be any mappable object. See Sections 4,5, and 6
401951	1950	0x079F	1	Control number#6	Byte	0	0..255	N/A	R/W	CAN input signal offset for continuous input signals.
401952	1951	0x07A1	1	Signal resolution#6	Byte	0	0..3	N/A	R/W	Shows the number of decimal digits
401953	1952	0x07A2	1	Signal offset#6	Word	0	0..65535	N/A	R/W	Defines the offset for the signal
401954	1953	0x07A3	1	Signal data size#6	Byte	0	0, 8, 16, 24, 32	N/A	R/W	Defines the number of bits. Can only be equal to 0,1,2,3 and 4 bytes
401955	1954	0x07A4	1	Control source#7	Word	0	0xFFFFh	N/A	R/W	Source of the output for last 2 bytes. Can be any mappable object. See Sections 4,5, and 6
401956	1955	0x07A5	1	Control number#7	Byte	0	0..255	N/A	R/W	CAN input signal offset for continuous input signals.
401957	1956	0x07A6	1	Signal resolution#7	Byte	0	0..3	N/A	R/W	Shows the number of decimal digits
401958	1957	0x07A7	1	Signal offset#7	Word	0	0..65535	N/A	R/W	Defines the offset for the signal
401959	1958	0x07A8	1	Signal data size#7	Byte	0	0, 8, 16, 24, 32	N/A	R/W	Defines the number of bits. Can only be equal to 0,1,2,3 and 4 bytes
401960	1959	0x07A9	1	Control source#8	Word	0	0xFFFFh	N/A	R/W	Source of the output for last 2 bytes. Can be any mappable object. See Sections 4,5, and 6
401961	1960	0x07AA	1	Control number#8	Byte	0	0..255	N/A	R/W	CAN input signal offset for continuous input signals.

Bit/Reg Address	Modbus Address		# of Reg	Name	Format	Default	Range	Units or Res.	Access	Description
	Dec	Hex								
401962	1961	0x07AB	1	Signal resolution#8	Byte	0	0...3	N/A	R/W	Shows the number of decimal digits
401963	1962	0x07AC	1	Signal offset#8	Word	0	0...65535	N/A	R/W	Defines the offset for the signal
401964	1963	0x07AD	1	Signal data size#8	Byte	0	0, 8, 16, 24, 32	N/A	R/W	Defines the number of bits. Can only be equal to 0,1,2,3 and 4 bytes
401965	1964	0x07AE	5	Reserved	N/A	N/A	N/A	N/A	RO	Reserved for future use. Reading results in 0. Writing is allowed but does not change the value.
CAN Output Message #3										
401969	1968	0x07B0	1	COB ID	Word	1FF	Up to 7FF	N/A	R/W	CAN message 11 bit ID
401970	1969	0x07B1	1	Transmission Enable	Byte	1 - No	1 - No, 0 - Yes	N/A	R/W	Transmission Enable. Enables the CAN output message transmission
401971	1970	0x07B2	1	Transmission Rate	Word	100	0...10000	ms	R/W	CAN output message transmission rate. If 0 – transmission is upon request.
401972	1971	0x07B3	1	Transmission type	Byte	254	254	N/A	RO	Type of a communication. 254 – asynchronous transmit
401973	1972	0x07B4	1	Control source#1	Word	0	0xFFFFh	N/A	R/W	Source of the output for first 2 bytes. Can be any mappable object. See Sections 4,5, and 6
401974	1973	0x07B5	1	Control number#1	Byte	0	0..255	N/A	R/W	Defines a subindex of a chosen object.
401975	1974	0x07B6	1	Signal resolution#1	Byte	0	0...3	N/A	R/W	Shows the number of decimal digits
401976	1975	0x07B7	1	Signal offset#1	Word	0	0...65535	N/A	R/W	Defines the offset for the signal
401977	1976	0x07B8	1	Signal data size#1	Byte	0	0, 8, 16, 24, 32	N/A	R/W	Defines the number of bits. Can only be equal to 0,1,2,3 and 4 bytes

Bit/Reg Address	Modbus Address		# of Reg	Name	Format	Default	Range	Units or Res.	Access	Description
	Dec	Hex								
401978	1977	0x07B9	1	Control source#2	Word	0	0xFFFFh	N/A	R/W	Source of the output for second 2 bytes. Can be any mappable object. See Sections 4,5, and 6
401979	1978	0x07BA	1	Control number#2	Byte	0	0..255	N/A	R/W	CAN input signal size
401980	1979	0x07BB	1	Signal resolution#2	Byte	0	0...3	N/A	R/W	Shows the number of decimal digits
401981	1980	0x07BC	1	Signal offset#2	Word	0	0...65535	N/A	R/W	Defines the offset for the signal
401982	1981	0x07BD	1	Signal data size#2	Byte	0	0, 8, 16, 24, 32	N/A	R/W	Defines the number of bits. Can only be equal to 0,1,2,3 and 4 bytes
401983	1982	0x07BE	1	Control source#3	Word	0	0xFFFFh	N/A	R/W	Source of the output for third 2 bytes. Can be any mappable object. See Sections 4,5, and 6
401984	1983	0x07BF	1	Control number#3	Byte	0	0..255	N/A	R/W	CAN input signal offset for continuous input signals.
401985	1984	0x07C0	1	Signal resolution#3	Byte	0	0...3	N/A	R/W	Shows the number of decimal digits
401986	1985	0x07C1	1	Signal offset#3	Word	0	0...65535	N/A	R/W	Defines the offset for the signal
401987	1986	0x07C2	1	Signal data size#3	Byte	0	0, 8, 16, 24, 32	N/A	R/W	Defines the number of bits. Can only be equal to 0,1,2,3 and 4 bytes
401988	1987	0x07C3	1	Control source#4	Word	0	0xFFFFh	N/A	R/W	Source of the output for last 2 bytes. Can be any mappable object. See Sections 4,5, and 6
401989	1988	0x07C4	1	Control number#4	Byte	0	0..255	N/A	R/W	CAN input signal offset for continuous input signals.
401990	1989	0x07C5	1	Signal resolution#4	Byte	0	0...3	N/A	R/W	Shows the number of decimal digits
401991	1990	0x07C6	1	Signal offset#4	Word	0	0...65535	N/A	R/W	Defines the offset for the signal

Bit/Reg Address	Modbus Address		# of Reg	Name	Format	Default	Range	Units or Res.	Access	Description
	Dec	Hex								
401992	1991	0x07C7	1	Signal data size#4	Byte	0	0, 8, 16, 24, 32	N/A	R/W	Defines the number of bits. Can only be equal to 0,1,2,3 and 4 bytes
401993	1992	0x07C8	1	Control source#5	Word	0	0xFFFFh	N/A	R/W	Source of the output for last 2 bytes. Can be any mappable object. See Sections 4,5, and 6
401994	1993	0x07C9	1	Control number#5	Byte	0	0..255	N/A	R/W	CAN input signal offset for continuous input signals.
401995	1994	0x07CA	1	Signal resolution#5	Byte	0	0..3	N/A	R/W	Shows the number of decimal digits
401996	1995	0x07CB	1	Signal offset#5	Word	0	0..65535	N/A	R/W	Defines the offset for the signal
401997	1996	0x07CC	1	Signal data size#5	Byte	0	0, 8, 16, 24, 32	N/A	R/W	Defines the number of bits. Can only be equal to 0,1,2,3 and 4 bytes
401998	1997	0x07CD	1	Control source#6	Word	0	0xFFFFh	N/A	R/W	Source of the output for last 2 bytes. Can be any mappable object. See Sections 4,5, and 6
401999	1998	0x07CE	1	Control number#6	Byte	0	0..255	N/A	R/W	CAN input signal offset for continuous input signals.
402000	1999	0x07CF	1	Signal resolution#6	Byte	0	0..3	N/A	R/W	Shows the number of decimal digits
402001	2000	0x07D0	1	Signal offset#6	Word	0	0..65535	N/A	R/W	Defines the offset for the signal
402002	2001	0x07D1	1	Signal data size#6	Byte	0	0, 8, 16, 24, 32	N/A	R/W	Defines the number of bits. Can only be equal to 0,1,2,3 and 4 bytes
402003	2002	0x07D2	1	Control source#7	Word	0	0xFFFFh	N/A	R/W	Source of the output for last 2 bytes. Can be any mappable object. See Sections 4,5, and 6
402004	2003	0x07D3	1	Control number#7	Byte	0	0..255	N/A	R/W	CAN input signal offset for continuous input signals.

Bit/Reg Address	Modbus Address		# of Reg	Name	Format	Default	Range	Units or Res.	Access	Description
	Dec	Hex								
402005	2004	0x07D4	1	Signal resolution#7	Byte	0	0...3	N/A	R/W	Shows the number of decimal digits
402006	2005	0x07D5	1	Signal offset#7	Word	0	0...65535	N/A	R/W	Defines the offset for the signal
402007	2006	0x07D6	1	Signal data size#7	Byte	0	0, 8, 16, 24, 32	N/A	R/W	Defines the number of bits. Can only be equal to 0,1,2,3 and 4 bytes
402008	2007	0x07D7	1	Control source#8	Word	0	0xFFFFh	N/A	R/W	Source of the output for last 2 bytes. Can be any mappable object. See Sections 4,5, and 6
402009	2008	0x07D8	1	Control number#8	Byte	0	0..255	N/A	R/W	CAN input signal offset for continuous input signals.
402010	2009	0x07D9	1	Signal resolution#8	Byte	0	0...3	N/A	R/W	Shows the number of decimal digits
402011	2010	0x07DA	1	Signal offset#8	Word	0	0...65535	N/A	R/W	Defines the offset for the signal
402012	2011	0x07DB	1	Signal data size#8	Byte	0	0, 8, 16, 24, 32	N/A	R/W	Defines the number of bits. Can only be equal to 0,1,2,3 and 4 bytes
402013	2012	0x07DC	5	Reserved	N/A	N/A	N/A	N/A	RO	Reserved for future use. Reading results in 0. Writing is allowed but does not change the value.
CAN Output Message #4										
402017	2016	0x07E0	1	COB ID	Word	1FF	Up to 7FF	N/A	R/W	CAN message 11 bit ID
402018	2017	0x07E1	1	Transmission Enable	Byte	1 - No	1 - No, 0 - Yes	N/A	R/W	Transmission Enable. Enables the CAN output message transmission
402019	2018	0x07E2	1	Transmission Rate	Word	100	0...10000	ms	R/W	CAN output message transmission rate. If 0 – transmission is upon request.
402020	2019	0x07E3	1	Transmission type	Byte	254	254	N/A	RO	Type of a communication. 254 – asynchronous transmit

Bit/Reg Address	Modbus Address		# of Reg	Name	Format	Default	Range	Units or Res.	Access	Description
	Dec	Hex								
402021	2020	0x07E4	1	Control source#1	Word	0	0xFFFFh	N/A	R/W	Source of the output for first 2 bytes. Can be any mappable object. See Sections 4,5, and 6
402022	2021	0x07E5	1	Control number#1	Byte	0	0..255	N/A	R/W	Defines a subindex of a chosen object.
402023	2022	0x07E6	1	Signal resolution#1	Byte	0	0...3	N/A	R/W	Shows the number of decimal digits
402024	2023	0x07E7	1	Signal offset#1	Word	0	0...65535	N/A	R/W	Defines the offset for the signal
402025	2024	0x07E8	1	Signal data size#1	Byte	0	0, 8, 16, 24, 32	N/A	R/W	Defines the number of bits. Can only be equal to 0,1,2,3 and 4 bytes
402026	2025	0x07E9	1	Control source#2	Word	0	0xFFFFh	N/A	R/W	Source of the output for second 2 bytes. Can be any mappable object. See Sections 4,5, and 6
402027	2026	0x07EA	1	Control number#2	Byte	0	0..255	N/A	R/W	CAN input signal size
402028	2027	0x07EB	1	Signal resolution#2	Byte	0	0...3	N/A	R/W	Shows the number of decimal digits
402029	2028	0x07EC	1	Signal offset#2	Word	0	0...65535	N/A	R/W	Defines the offset for the signal
402030	2029	0x07ED	1	Signal data size#2	Byte	0	0, 8, 16, 24, 32	N/A	R/W	Defines the number of bits. Can only be equal to 0,1,2,3 and 4 bytes
402031	2030	0x07EE	1	Control source#3	Word	0	0xFFFFh	N/A	R/W	Source of the output for third 2 bytes. Can be any mappable object. See Sections 4,5, and 6
402032	2031	0x07EF	1	Control number#3	Byte	0	0..255	N/A	R/W	CAN input signal offset for continuous input signals.
402033	2032	0x07F0	1	Signal resolution#3	Byte	0	0...3	N/A	R/W	Shows the number of decimal digits
402034	2033	0x07F1	1	Signal offset#3	Word	0	0...65535	N/A	R/W	Defines the offset for the signal
402035	2034	0x07F2	1	Signal data size#3	Byte	0	0, 8, 16, 24, 32	N/A	R/W	Defines the number of bits. Can only be equal to 0,1,2,3 and 4 bytes

Bit/Reg Address	Modbus Address		# of Reg	Name	Format	Default	Range	Units or Res.	Access	Description
	Dec	Hex								
402036	2035	0x07F3	1	Control source#4	Word	0	0xFFFFh	N/A	R/W	Source of the output for last 2 bytes. Can be any mappable object. See Sections 4,5, and 6
402037	2036	0x07F4	1	Control number#4	Byte	0	0..255	N/A	R/W	CAN input signal offset for continuous input signals.
402038	2037	0x07F5	1	Signal resolution#4	Byte	0	0..3	N/A	R/W	Shows the number of decimal digits
402039	2038	0x07F6	1	Signal offset#4	Word	0	0..65535	N/A	R/W	Defines the offset for the signal
402040	2039	0x07F7	1	Signal data size#4	Byte	0	0, 8, 16, 24, 32	N/A	R/W	Defines the number of bits. Can only be equal to 0,1,2,3 and 4 bytes
402041	2040	0x07F8	1	Control source#5	Word	0	0xFFFFh	N/A	R/W	Source of the output for last 2 bytes. Can be any mappable object. See Sections 4,5, and 6
402042	2041	0x07F9	1	Control number#5	Byte	0	0..255	N/A	R/W	CAN input signal offset for continuous input signals.
402043	2042	0x07FA	1	Signal resolution#5	Byte	0	0..3	N/A	R/W	Shows the number of decimal digits
402044	2043	0x07FB	1	Signal offset#5	Word	0	0..65535	N/A	R/W	Defines the offset for the signal
402045	2044	0x07FC	1	Signal data size#5	Byte	0	0, 8, 16, 24, 32	N/A	R/W	Defines the number of bits. Can only be equal to 0,1,2,3 and 4 bytes
402046	2045	0x07FD	1	Control source#6	Word	0	0xFFFFh	N/A	R/W	Source of the output for last 2 bytes. Can be any mappable object. See Sections 4,5, and 6
402047	2046	0x07FE	1	Control number#6	Byte	0	0..255	N/A	R/W	CAN input signal offset for continuous input signals.
402048	2047	0x07FF	1	Signal resolution#6	Byte	0	0..3	N/A	R/W	Shows the number of decimal digits
402049	2048	0x0800	1	Signal offset#6	Word	0	0..65535	N/A	R/W	Defines the offset for the signal

Bit/Reg Address	Modbus Address		# of Reg	Name	Format	Default	Range	Units or Res.	Access	Description
	Dec	Hex								
402050	2049	0x0801	1	Signal data size#6	Byte	0	0, 8, 16, 24, 32	N/A	R/W	Defines the number of bits. Can only be equal to 0,1,2,3 and 4 bytes
402051	2050	0x0802	1	Control source#7	Word	0	0xFFFFh	N/A	R/W	Source of the output for last 2 bytes. Can be any mappable object. See Sections 4,5, and 6
402052	2051	0x0803	1	Control number#7	Byte	0	0..255	N/A	R/W	CAN input signal offset for continuous input signals.
402053	2052	0x0804	1	Signal resolution#7	Byte	0	0..3	N/A	R/W	Shows the number of decimal digits
402054	2053	0x0805	1	Signal offset#7	Word	0	0..65535	N/A	R/W	Defines the offset for the signal
402055	2054	0x0806	1	Signal data size#7	Byte	0	0, 8, 16, 24, 32	N/A	R/W	Defines the number of bits. Can only be equal to 0,1,2,3 and 4 bytes
402056	2055	0x0809	1	Control source#8	Word	0	0xFFFFh	N/A	R/W	Source of the output for last 2 bytes. Can be any mappable object. See Sections 4,5, and 6
402057	2056	0x080A	1	Control number#8	Byte	0	0..255	N/A	R/W	CAN input signal offset for continuous input signals.
402058	2057	0x080B	1	Signal resolution#8	Byte	0	0..3	N/A	R/W	Shows the number of decimal digits
402059	2058	0x080C	1	Signal offset#8	Word	0	0..65535	N/A	R/W	Defines the offset for the signal
402060	2059	0x080D	1	Signal data size#8	Byte	0	0, 8, 16, 24, 32	N/A	R/W	Defines the number of bits. Can only be equal to 0,1,2,3 and 4 bytes
402061	2060	0x080E	5	Reserved	N/A	N/A	N/A	N/A	RO	Reserved for future use. Reading results in 0. Writing is allowed but does not change the value.
CAN Output Message #5										
402065	2064	0x0810	1	COB ID	Word	1FF	Up to 7FF	N/A	R/W	CAN message 11 bit ID

Bit/Reg Address	Modbus Address		# of Reg	Name	Format	Default	Range	Units or Res.	Access	Description
	Dec	Hex								
402066	2065	0x0811	1	Transmission Enable	Byte	1 - No	1 - No, 0 - Yes	N/A	R/W	Transmission Enable. Enables the CAN output message transmission
402067	2066	0x0812	1	Transmission Rate	Word	100	0...10000	ms	R/W	CAN output message transmission rate. If 0 – transmission is upon request.
402068	2067	0x0813	1	Transmission type	Byte	254	254	N/A	RO	Type of a communication. 254 – asynchronous transmit
402069	2068	0x0814	1	Control source#1	Word	0	0xFFFFh	N/A	R/W	Source of the output for first 2 bytes. Can be any mappable object. See Sections 4,5, and 6
402070	2069	0x0815	1	Control number#1	Byte	0	0..255	N/A	R/W	Defines a subindex of a chosen object.
402071	2070	0x0816	1	Signal resolution#1	Byte	0	0...3	N/A	R/W	Shows the number of decimal digits
402072	2071	0x0817	1	Signal offset#1	Word	0	0...65535	N/A	R/W	Defines the offset for the signal
402073	2072	0x0818	1	Signal data size#1	Byte	0	0, 8, 16, 24, 32	N/A	R/W	Defines the number of bits. Can only be equal to 0,1,2,3 and 4 bytes
402074	2073	0x0819	1	Control source#2	Word	0	0xFFFFh	N/A	R/W	Source of the output for second 2 bytes. Can be any mappable object. See Sections 4,5, and 6
402075	2074	0x081A	1	Control number#2	Byte	0	0..255	N/A	R/W	CAN input signal size
402076	2075	0x081B	1	Signal resolution#2	Byte	0	0...3	N/A	R/W	Shows the number of decimal digits
402077	2076	0x081C	1	Signal offset#2	Word	0	0...65535	N/A	R/W	Defines the offset for the signal
402078	2077	0x081D	1	Signal data size#2	Byte	0	0, 8, 16, 24, 32	N/A	R/W	Defines the number of bits. Can only be equal to 0,1,2,3 and 4 bytes
402079	2078	0x081E	1	Control source#3	Word	0	0xFFFFh	N/A	R/W	Source of the output for third 2 bytes. Can be

Bit/Reg Address	Modbus Address		# of Reg	Name	Format	Default	Range	Units or Res.	Access	Description
	Dec	Hex								
										any mappable object. See Sections 4,5, and 6
402080	2079	0x081F	1	Control number#3	Byte	0	0..255	N/A	R/W	CAN input signal offset for continuous input signals.
402081	2080	0x0820	1	Signal resolution#3	Byte	0	0...3	N/A	R/W	Shows the number of decimal digits
402082	2081	0x0821	1	Signal offset#3	Word	0	0...65535	N/A	R/W	Defines the offset for the signal
402083	2082	0x0822	1	Signal data size#3	Byte	0	0, 8, 16, 24, 32	N/A	R/W	Defines the number of bits. Can only be equal to 0,1,2,3 and 4 bytes
402084	2083	0x0823	1	Control source#4	Word	0	0xFFFFh	N/A	R/W	Source of the output for last 2 bytes. Can be any mappable object. See Sections 4,5, and 6
402085	2084	0x0824	1	Control number#4	Byte	0	0..255	N/A	R/W	CAN input signal offset for continuous input signals.
402086	2085	0x0825	1	Signal resolution#4	Byte	0	0...3	N/A	R/W	Shows the number of decimal digits
402087	2086	0x0826	1	Signal offset#4	Word	0	0...65535	N/A	R/W	Defines the offset for the signal
402088	2087	0x0827	1	Signal data size#4	Byte	0	0, 8, 16, 24, 32	N/A	R/W	Defines the number of bits. Can only be equal to 0,1,2,3 and 4 bytes
402089	2088	0x0828	1	Control source#5	Word	0	0xFFFFh	N/A	R/W	Source of the output for last 2 bytes. Can be any mappable object. See Sections 4,5, and 6
402090	2089	0x0829	1	Control number#5	Byte	0	0..255	N/A	R/W	CAN input signal offset for continuous input signals.
402091	2090	0x082A	1	Signal resolution#5	Byte	0	0...3	N/A	R/W	Shows the number of decimal digits
402092	2091	0x082B	1	Signal offset#5	Word	0	0...65535	N/A	R/W	Defines the offset for the signal

Bit/Reg Address	Modbus Address		# of Reg	Name	Format	Default	Range	Units or Res.	Access	Description
	Dec	Hex								
402093	2092	0x082C	1	Signal data size#5	Byte	0	0, 8, 16, 24, 32	N/A	R/W	Defines the number of bits. Can only be equal to 0,1,2,3 and 4 bytes
402094	2093	0x082D	1	Control source#6	Word	0	0xFFFFh	N/A	R/W	Source of the output for last 2 bytes. Can be any mappable object. See Sections 4,5, and 6
402095	2094	0x082E	1	Control number#6	Byte	0	0..255	N/A	R/W	CAN input signal offset for continuous input signals.
402096	2095	0x082F	1	Signal resolution#6	Byte	0	0..3	N/A	R/W	Shows the number of decimal digits
402097	2096	0x0830	1	Signal offset#6	Word	0	0..65535	N/A	R/W	Defines the offset for the signal
402098	2097	0x0831	1	Signal data size#6	Byte	0	0, 8, 16, 24, 32	N/A	R/W	Defines the number of bits. Can only be equal to 0,1,2,3 and 4 bytes
402099	2098	0x0832	1	Control source#7	Word	0	0xFFFFh	N/A	R/W	Source of the output for last 2 bytes. Can be any mappable object. See Sections 4,5, and 6
402100	2099	0x0833	1	Control number#7	Byte	0	0..255	N/A	R/W	CAN input signal offset for continuous input signals.
402101	2100	0x0834	1	Signal resolution#7	Byte	0	0..3	N/A	R/W	Shows the number of decimal digits
402102	2101	0x0835	1	Signal offset#7	Word	0	0..65535	N/A	R/W	Defines the offset for the signal
402103	2102	0x0836	1	Signal data size#7	Byte	0	0, 8, 16, 24, 32	N/A	R/W	Defines the number of bits. Can only be equal to 0,1,2,3 and 4 bytes
402104	2103	0x0839	1	Control source#8	Word	0	0xFFFFh	N/A	R/W	Source of the output for last 2 bytes. Can be any mappable object. See Sections 4,5, and 6
402105	2104	0x083A	1	Control number#8	Byte	0	0..255	N/A	R/W	CAN input signal offset for continuous input signals.

Bit/Reg Address	Modbus Address		# of Reg	Name	Format	Default	Range	Units or Res.	Access	Description
	Dec	Hex								
402106	2105	0x083B	1	Signal resolution#8	Byte	0	0...3	N/A	R/W	Shows the number of decimal digits
402107	2106	0x083C	1	Signal offset#8	Word	0	0...65535	N/A	R/W	Defines the offset for the signal
402108	2107	0x083D	1	Signal data size#8	Byte	0	0, 8, 16, 24, 32	N/A	R/W	Defines the number of bits. Can only be equal to 0,1,2,3 and 4 bytes
402109	2108	0x083E	5	Reserved	N/A	N/A	N/A	N/A	RO	Reserved for future use. Reading results in 0. Writing is allowed but does not change the value.

10 THIRD-PARTY SOFTWARE LICENSE NOTICES

This section contains Third-Party Software License Notices and/or Additional Terms and Conditions for licensed third-party software components included in the 2 Bipolar, 8 Universal Signal Input Controller with SAE J1939 and Ethernet firmware.

Table 32. Third-Party Software License Notices

Third-Party Software	License Notice/Terms
STMicroelectronics microcontroller support software	<p>COPYRIGHT(c) 2017 STMicroelectronics Redistribution and use in source and binary forms, with or without modification, are permitted provided that the following conditions are met: Redistributions of source code must retain the above copyright notice, this list of conditions and the following disclaimer. Redistributions in binary form must reproduce the above copyright notice, this list of conditions and the following disclaimer in the documentation and/or other materials provided with the distribution. Neither the name of STMicroelectronics nor the names of its contributors may be used to endorse or promote products derived from this software without specific prior written permission. THIS SOFTWARE IS PROVIDED BY THE COPYRIGHT HOLDERS AND CONTRIBUTORS "AS IS" AND ANY EXPRESS OR IMPLIED WARRANTIES, INCLUDING, BUT NOT LIMITED TO, THE IMPLIED WARRANTIES OF MERCHANTABILITY AND FITNESS FOR A PARTICULAR PURPOSE ARE DISCLAIMED. IN NO EVENT SHALL THE COPYRIGHT HOLDER OR CONTRIBUTORS BE LIABLE FOR ANY DIRECT, INDIRECT, INCIDENTAL, SPECIAL, EXEMPLARY, OR CONSEQUENTIAL DAMAGES (INCLUDING, BUT NOT LIMITED TO, PROCUREMENT OF SUBSTITUTE GOODS OR SERVICES; LOSS OF USE, DATA, OR PROFITS; OR BUSINESS INTERRUPTION) HOWEVER CAUSED AND ON ANY THEORY OF LIABILITY, WHETHER IN CONTRACT, STRICT LIABILITY, OR TORT (INCLUDING NEGLIGENCE OR OTHERWISE) ARISING IN ANY WAY OUT OF THE USE OF THIS SOFTWARE, EVEN IF ADVISED OF THE POSSIBILITY OF SUCH DAMAGE.</p> <p>Licensed under MCD-ST Liberty SW License Agreement V2, (the "License"); You may not use this file except in compliance with the License. You may obtain a copy of the License at: http://www.st.com/software_license_agreement_liberty_v2 Unless required by applicable law or agreed to in writing, software distributed under the License is distributed on an "AS IS" BASIS, WITHOUT WARRANTIES OR CONDITIONS OF ANY KIND, either express or implied. See the License for the specific language governing permissions and limitations under the License.</p>
FreeRTOS Kernel V10.2.0	<p>Copyright (C) 2019 Amazon.com, Inc. or its affiliates. All Rights Reserved.</p> <p>Permission is hereby granted, free of charge, to any person obtaining a copy of this software and associated documentation files (the "Software"), to deal in the Software without restriction, including without limitation the rights to use, copy, modify, merge, publish, distribute, sublicense, and/or sell copies of the Software, and to permit persons to whom the Software is furnished to do so, subject to the following conditions: The above copyright notice and this permission notice shall be included in all copies or substantial portions of the Software.</p>

Third-Party Software	License Notice/Terms
	<p>THE SOFTWARE IS PROVIDED "AS IS", WITHOUT WARRANTY OF ANY KIND, EXPRESS OR IMPLIED, INCLUDING BUT NOT LIMITED TO THE WARRANTIES OF MERCHANTABILITY, FITNESS FOR A PARTICULAR PURPOSE AND NONINFRINGEMENT. IN NO EVENT SHALL THE AUTHORS OR COPYRIGHT HOLDERS BE LIABLE FOR ANY CLAIM, DAMAGES OR OTHER LIABILITY, WHETHER IN AN ACTION OF CONTRACT, TORT OR OTHERWISE, ARISING FROM, OUT OF OR IN CONNECTION WITH THE SOFTWARE OR THE USE OR OTHER DEALINGS IN THE SOFTWARE.</p>
FreeRTOS+TCP V2.2.0	<p>Copyright (C) 2017 Amazon.com, Inc. or its affiliates. All Rights Reserved.</p> <p>Permission is hereby granted, free of charge, to any person obtaining a copy of this software and associated documentation files (the "Software"), to deal in the Software without restriction, including without limitation the rights to use, copy, modify, merge, publish, distribute, sublicense, and/or sell copies of the Software, and to permit persons to whom the Software is furnished to do so, subject to the following conditions: The above copyright notice and this permission notice shall be included in all copies or substantial portions of the Software.</p> <p>THE SOFTWARE IS PROVIDED "AS IS", WITHOUT WARRANTY OF ANY KIND, EXPRESS OR IMPLIED, INCLUDING BUT NOT LIMITED TO THE WARRANTIES OF MERCHANTABILITY, FITNESS FOR A PARTICULAR PURPOSE AND NONINFRINGEMENT. IN NO EVENT SHALL THE AUTHORS OR COPYRIGHT HOLDERS BE LIABLE FOR ANY CLAIM, DAMAGES OR OTHER LIABILITY, WHETHER IN AN ACTION OF CONTRACT, TORT OR OTHERWISE, ARISING FROM, OUT OF OR IN CONNECTION WITH THE SOFTWARE OR THE USE OR OTHER DEALINGS IN THE SOFTWARE.</p>

11 VERSION HISTORY

User Manual Version	Firmware version	Date	Author	Modifications
1	1.xx	October 15, 2021	Dmytro Tsebrii	<ul style="list-style-type: none">• Initial release
-	-	January 24, 2022	Amanda Wilkins	<ul style="list-style-type: none">• Marketing Review• CANopen® trademark Note added• Dimensional drawing updated and AX0321001 model drawing pending
1A	1.01	February 18, 2022	Dmytro Tsebrii	<ul style="list-style-type: none">• Updated defaults for TPDOs

OUR PRODUCTS

AC/DC Power Supplies
Actuator Controls/Interfaces
Automotive Ethernet Converters
Battery Chargers
CAN Controls, Routers, Repeaters
CAN/WiFi, CAN/Bluetooth, Routers
Current/Voltage Converters
DC/DC Power Converters
Engine Temperature Scanners
Ethernet/CAN Converters,
Gateways, Switches
Fan Drive Controllers
Gateways, CAN/Modbus Protocols
Gyroscope Inclinometers
Hydraulic Valve Controllers
Inclinometers, Triaxial
I/O Controls
LVDT Signal Converters
Machine Controls
Modbus Controls
Motor Controls
Power Supplies, DC/DC, AC/DC
PWM Signal Converters/Isolators
Resolver Signal Conditioners
Service Tools
Signal Conditioners, Converters
Strain Gauge CAN Controls
Surge Suppressors

OUR COMPANY

Axiomatic provides electronic machine control components to the off-highway, commercial vehicle, electric vehicle, power generator set, material handling, renewable energy and industrial OEM markets. ***We innovate with engineered and off-the-shelf machine controls that add value for our customers.***

QUALITY DESIGN AND MANUFACTURING

We have an ISO9001:2015 registered design/manufacturing facility in Canada.

WARRANTY, APPLICATION APPROVALS/LIMITATIONS

Axiomatic Technologies Corporation reserves the right to make corrections, modifications, enhancements, improvements, and other changes to its products and services at any time and to discontinue any product or service without notice. Customers should obtain the latest relevant information before placing orders and should verify that such information is current and complete. Users should satisfy themselves that the product is suitable for use in the intended application. All our products carry a limited warranty against defects in material and workmanship. Please refer to our Warranty, Application Approvals/Limitations and Return Materials Process at <https://www.axiomatic.com/service/>.

COMPLIANCE

Product compliance details can be found in the product literature and/or on axiomatic.com. Any inquiries should be sent to sales@axiomatic.com.

SAFE USE

All products should be serviced by Axiomatic. Do not open the product and perform the service yourself.



This product can expose you to chemicals which are known in the State of California, USA to cause cancer and reproductive harm. For more information go to www.P65Warnings.ca.gov.

SERVICE

All products to be returned to Axiomatic require a Return Materials Authorization Number (RMA#) from sales@axiomatic.com. Please provide the following information when requesting an RMA number:

- Serial number, part number
- Hours of operation, description of problem
- Wiring set up diagram, application and other comments as needed

DISPOSAL

Axiomatic products are electronic waste. Please follow your local environmental waste and recycling laws, regulations and policies for safe disposal or recycling of electronic waste.

CONTACTS

Axiomatic Technologies Corporation
5915 Wallace Street
Mississauga, ON
CANADA L4Z 1Z8
TEL: +1 905 602 9270
FAX: +1 905 602 9279
www.axiomatic.com
sales@axiomatic.com

Axiomatic Technologies Oy
Höytämöntie 6
33880 Lempäälä
FINLAND
TEL: +358 103 375 750
FAX: +358 3 3595 660
www.axiomatic.com
salesfinland@axiomatic.com