

USER MANUAL

Tri-Axial J1939 CAN Inclinometer

P/N: AX060800, AX060830 – Two M12 Connectors, Both CAN

P/N: AX061000 – Two M12 Connectors, CAN, 3 Analog Outputs

P/N: AX060808, AX060838 – Vertical Mount, Two M12 Connectors, Both CAN

P/N: AX060806, AX060810 – One DT13-4P Connector

P/N: AX060807, AX060811 – One DT13-4P Connector, CAN Termination

In Europe:
Axiomatic Technologies Oy
Höytämöntie 6
33880 Lempäälä - Finland
Tel. +358 103 375 750
Fax. +358 3 3595 660
www.axiomatic.fi

In North America:
Axiomatic Technologies Corporation
5915 Wallace Street
Mississauga, ON Canada L4Z 1Z8
Tel. 1 905 602 9270
Fax. 1 905 602 9279
www.axiomatic.com

ACRONYMS

3D	Three-Dimensional
CAN	Controller Area Network
CE	The CE mark, or formerly EC mark, is a mandatory conformity marking for certain products sold within the European Economic Area (EEA) since 1985
DM	Diagnostic message. Defined in J1939/73 standard
EA	Electronic Assistant [®] . PC application software from Axiomatic, primarily designed to view and program Axiomatic control configuration parameters (setpoints) through CAN bus using J1939 Memory Access Protocol
ECU	Electronic control unit
EMC	Electromagnetic compatibility
EMI	Electromagnetic Interference
G	Gravitational Acceleration on Earth
GPS	Global Positioning System
Grms	Root Mean Square Acceleration in G units
Hz	Hertz
IEC	International Electrotechnical Commission
LSB	Less Significant Byte
MEMS	Microelectromechanical system
NED	North-East-Down coordinate system
PC	Personal Computer
PGN	Parameter Group Number. Defined in J1939/73 standard
P/N	Part Number
RoHS	Restriction of Hazardous Substances
SAE J1939	CAN-based higher-level protocol designed and supported by the Society of Automobile Engineers (SAE)
SAE J670	Vehicle Dynamics Terminology standard designed and supported by the Society of Automobile Engineers (SAE)
SSI	Slope Sensor Information (PGN 61459)
SSI2	Slope Sensor Information 2 (PGN 61481)
UM	User Manual
USB	Universal Serial Bus
VDS	Voltage Direct Current or Vehicle Direction/Speed (PGN 65256)
VDS2	Vehicle Direction/Speed 2 (PGN 64905)
XOR	Exclusive or, a logical operation

TABLE OF CONTENTS

1	INTRODUCTION.....	5
2	INCLINOMETER DESCRIPTION.....	6
2.1	Theory of Operation.....	6
2.1.1	Unit Coordinate System.....	6
2.1.2	Unit Reference Frames.....	6
2.1.3	Angle measurements.....	7
2.1.3.1	Tilt Angles.....	8
2.1.3.2	Rotation Angles.....	9
2.1.3.2.1	Unit Rotation Angles.....	10
2.1.3.2.2	Euler Angles.....	11
2.1.3.2.3	Gimbal Lock.....	12
2.1.3.3	Maximum Gravity Acceleration Error.....	13
2.1.3.4	Practical Recommendations.....	13
2.1.3.5	Default Settings.....	15
2.2	Hardware Block Diagram.....	16
2.3	Software Organization.....	16
2.4	CAN Interface.....	17
2.4.1	CAN Baud Rate.....	18
2.4.2	J1939 Name and Address.....	18
2.4.3	Slew Rate Control.....	19
2.4.4	Network Bus Terminating Resistors.....	19
2.5	Default Settings.....	19
2.5.1	CAN Interface.....	19
2.5.1.1	PGN 61459, Slope Sensor Information, SSI.....	19
2.5.1.2	PGN 61481, Slope Sensor Information 2, SSI2.....	21
2.5.1.3	PGN 65256, Vehicle Direction/Speed, VDS.....	22
2.5.1.4	PGN 64905, Vehicle Direction/Speed 2, VDS2.....	23
2.5.2	Analog Outputs.....	24
3	INCLINOMETER LOGICAL STRUCTURE.....	25
3.1	Function Block Signals.....	26
3.1.1	Undefined Signal.....	26
3.1.2	Discrete Signal.....	26
3.1.3	Continuous Signal.....	26
3.1.4	Signal Type Conversion.....	27
3.1.4.1	Discrete to Continuous Conversion.....	27
3.1.4.2	Continuous to Discrete Conversion.....	27
3.1.4.3	Undefined Signal Conversion.....	27
3.2	Accelerometer.....	27
3.3	Angle Measurement.....	28
3.4	Unit Installation.....	29
3.4.1.1	Unit Frame Orientation Examples.....	30
3.5	Sensor Calibration.....	32
3.6	Binary Functions.....	32
3.7	Analog Signal Outputs.....	34
3.8	Global Parameters.....	36
3.9	J1939 Network.....	36
3.9.1	ECU Network Parameters.....	37

3.9.2	CAN Network Parameters.....	37
3.10	CAN Input Signal	38
3.11	CAN Output Message	40
4	CONFIGURATION PARAMETERS	43
4.1	Electronic Assistant Software.....	43
4.2	Function blocks in EA	44
4.3	Setpoint File	46
4.4	Configuration Example.....	47
4.4.1	User Requirements.....	47
4.4.2	Configuration Steps	47
4.4.3	Configuring Analog Signal Outputs.....	49
5	FLASHING NEW FIRMWARE	51
6	TECHNICAL SPECIFICATIONS	55
6.1	Performance Parameters.....	55
6.1.1	Angular Measurements.....	55
6.2	Power Supply Input.....	55
6.3	CAN Output.....	56
6.4	Analog Outputs	56
6.5	General Specifications	57
6.6	Inclinometer Modifications.....	58
6.7	Enclosures	58
6.7.1	AX060800.....	58
6.7.1.1	Connector Pinout	59
6.7.1.1.1	CAN Only.....	59
6.7.1.1.2	CAN and Analog Signal Outputs.....	59
6.7.1.2	Unit Orientation	60
6.7.2	AX060806.....	60
6.7.2.1	Connector Pinout	61
6.7.2.2	Unit Orientation	61
6.8	Installation.....	62
7	VERSION HISTORY	63

1 INTRODUCTION

The following user manual describes the architecture, functionality, configuration parameters and flashing instructions for Tri-Axial J1939 CAN Inclinerometers. It also contains technical specifications and installation instructions for the devices.

The application firmware version numbers described in the user manual, together with the EA version numbers supporting all inclinometer configuration parameters, are shown on the user manual front page.

The user manual is usually valid for application firmware with the same major version number as the user manual. For example, this user manual is valid for any inclinometer application firmware version 9.xx.

Updates specific to the user manual are done by adding letters: A, B, ..., Z to the user manual version number.

The user should check whether the application firmware installed in the inclinometer is covered by this user manual. It can be done using Axiomatic Electronic Assistant® (EA) software through CAN bus.

The inclinometers support SAE J1939 CAN interface. It is assumed, that the user is familiar with the J1939 group of standards. The terminology from these standards is widely used in this manual.

2 INCLINOMETER DESCRIPTION

The inclinometer is designed to measure pitch and roll inclination angles in a full ± 180 -degree orientation range. The unit can also output gravity angle and unit accelerations in three orthogonal directions.

The inclinometer transmits data over CAN bus using a standard J1939 protocol. In addition to the CAN bus, the AX0610000 inclinometer can output data using three analog signal outputs.

The J1939 inclinometer can operate at standard 250kbit/s and 500kbit/s baud rates or non-standard 667kbit/s and 1000kbit/s (1Mbit/s) baud rates. The required baud rate is detected automatically upon connection to the CAN network.¹

¹ *Inclinometers with firmware V1.xx...6.xx could operate only at 250kbit/s baud rate, and with firmware V7.xx...8.xx – at 250, 500, and 1000 kbit/s baud rates.*

The inclinometer can be configured through a set of configuration parameters to fit the user-specific application requirements using Axiomatic Electronic Assistant[®] software.

2.1 Theory of Operation

2.1.1 Unit Coordinate System

The inclinometer uses a standard right-handed Z-down Cartesian coordinate system, see Figure 1.

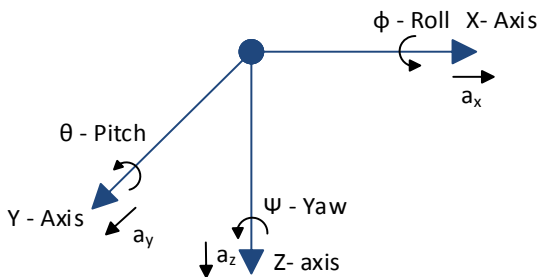

Figure 1. Inclinometer Coordinate System

The arrows in Figure 1 represent a direction of motion that produces a positive change of the parameter. For a_x , a_y , a_z accelerations, the positive acceleration direction is the same as the axis direction. For θ , ϕ , ψ rotation angles the positive direction is counterclockwise about the axis of rotation (right-hand rule).

The Z-down coordinate system is described by in the SAE J670 standard for automotive applications. It is used in SAE J1939 slope sensor PGN definitions. This system is similar to the NED (North-East-Down) coordinate system used in aerospace and navigation, but without reference to the cardinal directions.

2.1.2 Unit Reference Frames

Several Z-down coordinate systems or frames are used to describe the inclinometer orientation.

The (X,Y,Z) coordinate system attached to the unit forms a unit or inclinometer frame, see Figure 2. The original (default) unit frame orientation is shown on the inclinometer label. It can be changed using configuration parameters to facilitate the unit installation.

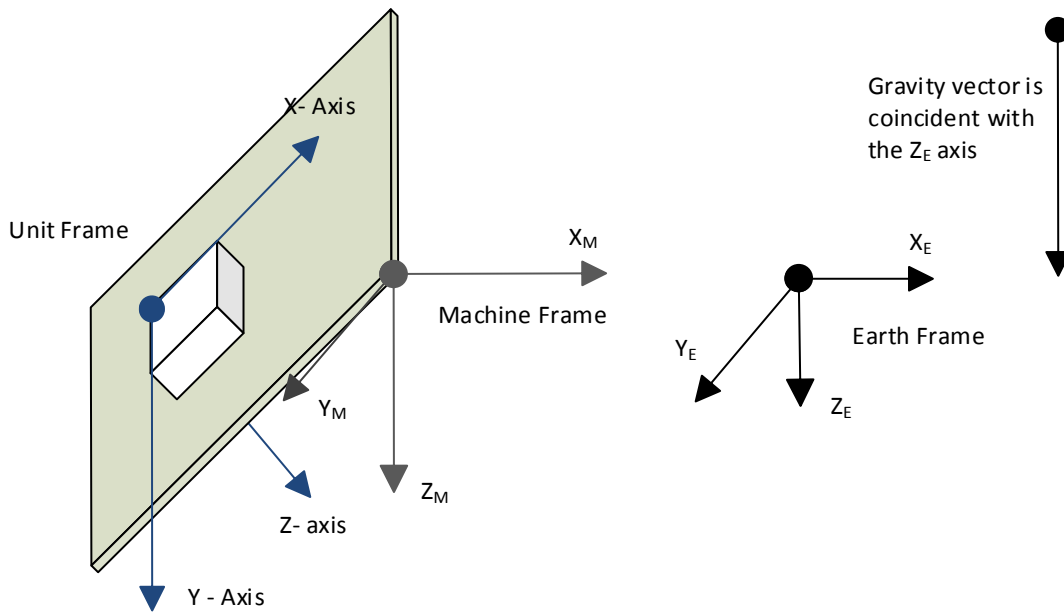

Figure 2. Inclinometer Reference Frames

The (X_M, Y_M, Z_M) coordinate system attached to the machine, where the inclinometer is installed, defines a machine frame. The Earth coordinate system (X_E, Y_E, Z_E) , aligned with the Earth gravity, defines the Earth absolute reference frame.

The machine frame is coincident with the Earth reference frame in the initial null-angle position of the machine when it is leveled on the operation area.

The unit calculates accelerations and angles referred to the machine frame (X_M, Y_M, Z_M) . Conversion from the unit frame (X, Y, Z) to the machine frame (X_M, Y_M, Z_M) is performed internally using the unit initial installation angles. They are set to zero by default.

After the inclinometer is installed on the machine at the customer site, the customer can set up the unit initial installation angles through configuration parameters.

To simplify further description of inclinometer operations, unless specially mentioned, it will be assumed that the unit frame orientation is original, initial installation angles are zero and all inclinometer parameters are referred therefore to the unit frame (X, Y, Z) .

2.1.3 Angle measurements

The inclination angles are measured by a three-axis MEMS accelerometer, which senses an acceleration vector \vec{a} in three orthogonal directions X, Y and Z:

$$\vec{a} = \vec{A} - \vec{g}, \tag{1}$$

where: $\vec{a} = (a_x, a_y, a_z)$ – acceleration measured by the unit,

$\vec{A} = (A_x, A_y, A_z)$ – external acceleration applied to the unit,

$\vec{g} = (g_x, g_y, g_z)$ – gravity acceleration.

The measured acceleration is then transformed into inclination angles based on the assumption that the only acceleration applied to the unit is the gravity acceleration \vec{g} caused by the gravity force:

$$\vec{a} = -\vec{g}, \text{ when } \vec{A} = 0. \quad (2)$$

The gravity acceleration is then:

$$\vec{g} = -\vec{a}. \quad (3)$$

The unit calculates θ – pitch, ϕ – roll, and ρ – gravity angles. There is not enough information based only on the unit accelerations to calculate the ψ – yaw angle.

The pitch and roll angles can be calculated in two different ways: as tilt or rotation angles. The gravity angle is always a tilt angle.

2.1.3.1 Tilt Angles

The pitch and roll tilt angles define the inclination of the unit relative to the ground plane. The gravity angle defines the inclination of the unit relative the gravity vector.

The pitch θ^t and roll ϕ^t tilt angles define the inclination of the unit relative to the (X_E, Y_E) ground plane parallel to the Earth surface in the Earth frame (X_E, Y_E, Z_E) , see Figure 3. The pitch angle θ^t is an angle between the vertical projection $X_{E(XY)^*}$ of the unit X axis onto the ground plane and the X axis. Similarly, the roll angle ϕ^t is an angle between the vertical projection $Y_{E(XY)^*}$ of the unit Y axis onto the ground plane and the Y axis.

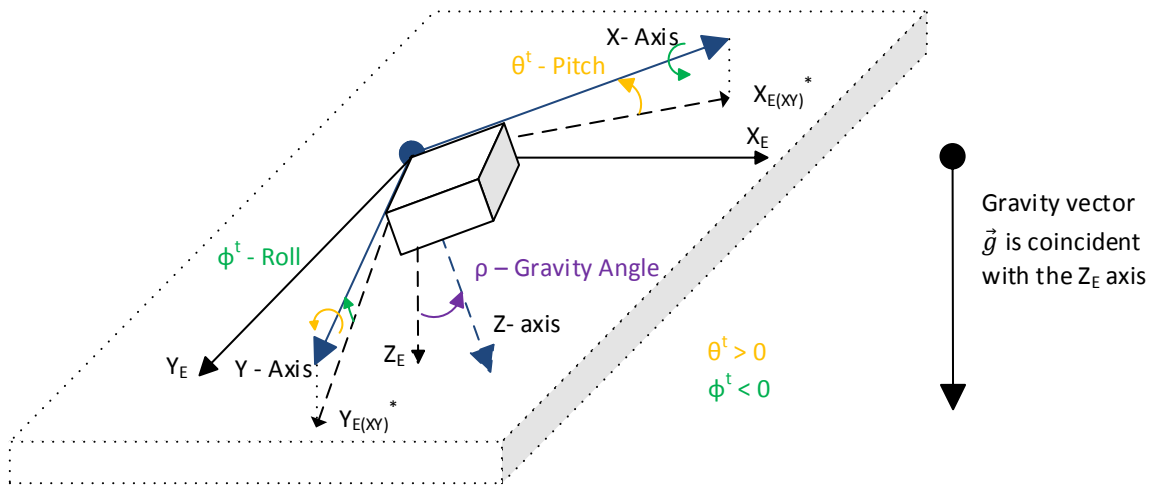

Plane (X_E, Y_E) is parallel to the Earth surface

Figure 3. Tilt Angles

The angle between the axes projections $X_{E(XY)^*}$ and $Y_{E(XY)^*}$ is not 90° in general case. It is 90° when the unit is parallel and 180° – when perpendicular to the ground plane.

The gravity angle ρ is an angle between the Z_E axis of the Earth frame and the unit Z axis.

The sign of the pitch and roll tilt angles is defined by the right-hand rule and presented by arrows about the Y and X axes. Since the pitch angle θ^t direction in Figure 3 is the same as the positive direction defined by the yellow arrow about the Y axis, the angle is positive. The same way, the roll angle ϕ^t direction is the opposite to the positive direction defined by the green arrow about the X axis. Therefore, the roll angle ϕ^t in Figure 3 is negative.

Depending on the application requirements, pitch and roll tilt angles can be calculated either in the $\pm 90^\circ$ or $\pm 180^\circ$ range using the unit measured accelerations: a_x, a_y, a_z .

For tilt angles in the $\pm 90^\circ$ range:

$$\theta^t = \text{atan2}(-g_x, \sqrt{g_y^2 + g_z^2}), \quad \theta^t \in [-90^\circ; 90^\circ], \quad (4)$$

$$\phi^t = \text{atan2}(g_y, \sqrt{g_x^2 + g_z^2}), \quad \phi^t \in [-90^\circ; 90^\circ],$$

For tilt angles in the $\pm 180^\circ$ range:

$$\theta^t = \text{atan2}(-g_x, \text{sign}(g_z) \cdot \sqrt{g_y^2 + g_z^2}), \quad \theta^t \in [-180^\circ; 180^\circ], \quad (5)$$

$$\phi^t = \text{atan2}(g_y, \text{sign}(g_z) \cdot \sqrt{g_x^2 + g_z^2}), \quad \phi^t \in [-180^\circ; 180^\circ],$$

$$\text{where: } \text{sign}(x) = \begin{cases} -1, & x < 0 \\ 1, & x \geq 0 \end{cases}$$

$$\text{and: } g_x = -a_x, \quad g_y = -a_y, \quad g_z = -a_z.$$

When measured in the $\pm 90^\circ$ range, the tilt angles are the angles that a dual-axis inclinometer (or two single-axis inclinometers placed in orthogonal directions) will measure in the same position as the unit. They will not detect a roll-over condition.

To detect a roll-over, the gravity angle can be used. The gravity angle is calculated using the following formula:

$$\rho = \text{atan2}(\sqrt{g_x^2 + g_y^2}, g_z), \quad \rho \in [0^\circ; 180^\circ]. \quad (6)$$

When $\rho > 90^\circ$, the roll-over occurs.

When pitch θ^t and roll ϕ^t angles are measured in the $\pm 180^\circ$ range, the tilt angles will detect a roll-over when: $|\theta^t| > 90^\circ$ or $|\phi^t| > 90^\circ$, but they will lose a smooth angular transition in the roll-over points.

When the unit is parallel to the Earth surface, all tilt angles are zero: $\theta^t = \phi^t = \rho = 0^\circ$.

2.1.3.2 Rotation Angles

In opposite to tilt angles that measure an inclination angle of the unit from a certain reference plane or a vector, the rotation angles measure a rotation angle of the unit about a certain axis.

The unit can measure two types of rotation angles: unit rotation angles and Euler angles.

2.1.3.2.1 Unit Rotation Angles

The unit rotation angles define rotations about the axes in the unit frame (X,Y,Z) the following way, see Figure 4.

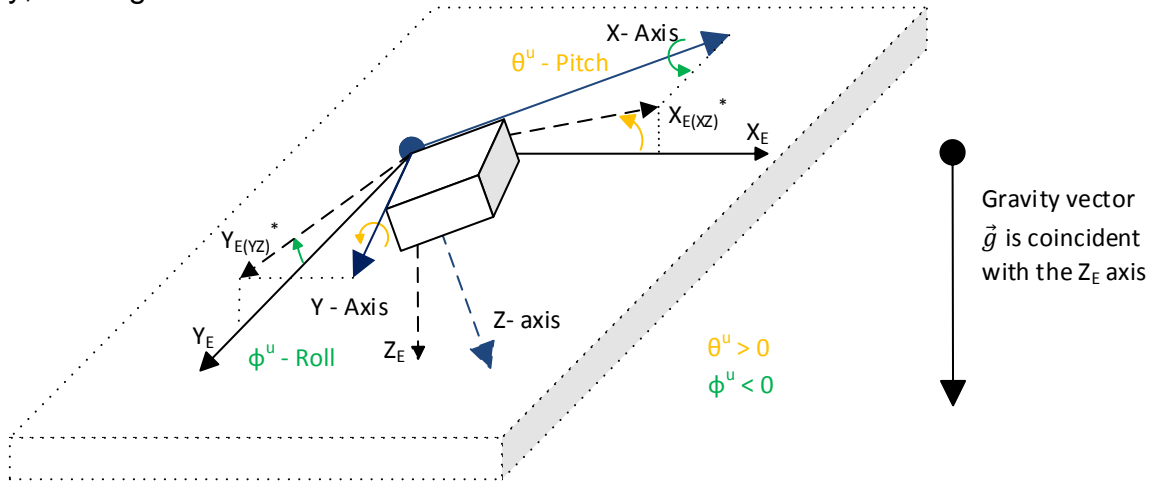

Plane (X_E, Y_E) is parallel to the Earth surface

Figure 4. Simple Rotation Angles

The rotation about the Y-axis defines the pitch angle θ^u and the rotation about the X axis – the roll angle ϕ^u . The pitch angle θ^u is an angle between the horizontal projection $X_{E(XZ)}^*$ of the unit X axis onto the (X_E, Z_E) plane and the X_E axis. Similarly, the roll angle ϕ^u is an angle between the horizontal projection $Y_{E(YZ)}^*$ of the unit Y axis onto the (Y_E, Z_E) plane and the Y_E axis.

The (X_E, Z_E) and (Y_E, Z_E) planes are perpendicular to the Earth surface (X_E, Y_E) in the Earth frame (X_E, Y_E, Z_E) . The angle between $X_{E(XZ)}^*$ and $Y_{E(YZ)}^*$ is always 90° .

The rotation about the Z-axis (yaw angle) is not shown in Figure 4. It cannot be calculated based on the gravity acceleration \vec{g} .

The sign of the pitch and roll angles is defined by the right-hand rule and presented by the arrows about the Y and X axes. Since the pitch angle θ^u direction in Figure 4 is the same as the positive direction defined by the yellow arrow about the Y axis, the angle is positive. The same way, the roll angle ϕ^u direction is the opposite to the positive direction defined by the green arrow about the X axis. Therefore, the roll angle ϕ^u in Figure 4 is negative.

The unit rotation angles are calculated using the following formulas:

$$\theta^u = \text{atan2}(-g_x, g_z), \quad \theta^u \in [-180^\circ; 180^\circ], \quad (7)$$

$$\phi^u = \text{atan2}(g_y, g_z), \quad \phi^u \in [-180^\circ; 180^\circ],$$

where: $g_x = -a_x$, $g_y = -a_y$, $g_z = -a_z$.

The roll-over condition is observed when: $|\theta^u| > 90^\circ$ or $|\phi^u| > 90^\circ$.

When the unit is parallel to the Earth surface, the unit rotation angles are zero: $\theta^u = \phi^u = 0^\circ$.

The unit rotation angles do not uniquely define the unit angular position in space. If this is required, the Euler angles should be used.

2.1.3.2.2 Euler Angles

The Euler angles are coordinate system rotation angles performed in a specific order to rotate the unit from its original position, parallel to the Earth surface, to its current position.

The Euler angles: θ^E and ϕ^E , together with the ψ^E , are rotation angles about the Z_E , Y_{E^*} and X axes performed in a standard (yaw, pitch, roll) rotation sequence used in aerospace and defined in SAE J670 standard for automotive applications, see Figure 5.

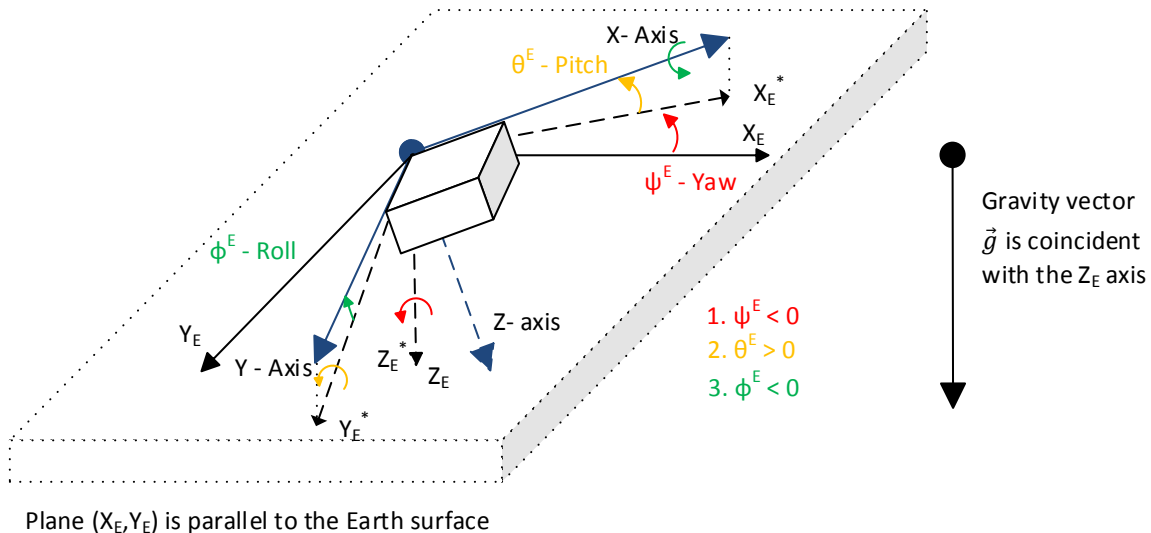

Figure 5. Euler Angles

The first rotation defines the ψ^E – yaw angle. It is performed about the Z_E axis of the Earth-fixed coordinate system (X_E, Y_E, Z_E) from the X_E axis to the X_{E^*} axis. An intermediate coordinate system ($X_{E^*}, Y_{E^*}, Z_{E^*}$) is a Z-down coordinate system whose X_{E^*} and Y_{E^*} axes are parallel to the ground plane (X_E, Y_E), with the X_{E^*} axis aligned with the vertical projection of the X axis onto the ground plane. Since the yaw rotation ψ^E on Figure 5 is opposite to the positive rotation direction, shown by the red arrow about the Z_E axis, the resulted angle is negative.

The second rotation defines the θ^E – pitch angle. It is performed about the Y_{E^*} axis of the intermediate coordinate system ($X_{E^*}, Y_{E^*}, Z_{E^*}$) from the X_{E^*} axis to the X axis. The pitch rotation θ^E on Figure 5 is in the positive rotation direction, defined by the yellow arrow about the Y_{E^*} axis, and the resulted angle is therefore positive.

The final third rotation defines the ϕ^E – roll angle, as a rotation about the X axis from the Y_{E^*} axis to the Y axis. The roll rotation ϕ^E on Figure 5 is negative. It is performed in the direction opposite to the positive rotation direction shown by the green arrow about the X axis.

The set of the three: yaw, pitch, and roll Euler angles fully represents the angular position of the inclinometer in space.

There is not enough information for the unit to calculate the yaw angle ψ^E , based only on the accelerometer data.

The Euler angles are calculated using the following formulas:

$$\theta^E = \text{atan2}(-g_x, \sqrt{g_y^2 + g_z^2}), \quad \theta^E \in [-90^\circ; 90^\circ], \quad (8)$$

$$\phi^E = \text{atan2}(g_y, g_z), \quad \phi^E \in [-180^\circ; 180^\circ],$$

where: $g_x = -a_x$, $g_y = -a_y$, $g_z = -a_z$.

The roll angles for both: the unit rotation and Euler angles are the same: $\phi^u = \phi^E$.

The roll-over condition is observed when: $|\phi^E| > 90^\circ$.

When the unit is parallel to the Earth surface, the Euler angles are zero: $\theta^E = \phi^E = 0^\circ$.

2.1.3.2.3 Gimbal Lock

The formulas for the roll angle ϕ^E and ϕ^u are numerically unstable when both: $g_y = g_z = 0$. This condition, called a gimbal lock, happens when the unit is placed in the vertical position with the X axis parallel to the gravity vector, see Figure 6. When this happens, the unit effectively loses one degree of freedom and the roll angles ϕ^E and ϕ^u become undefined and can take any random value.

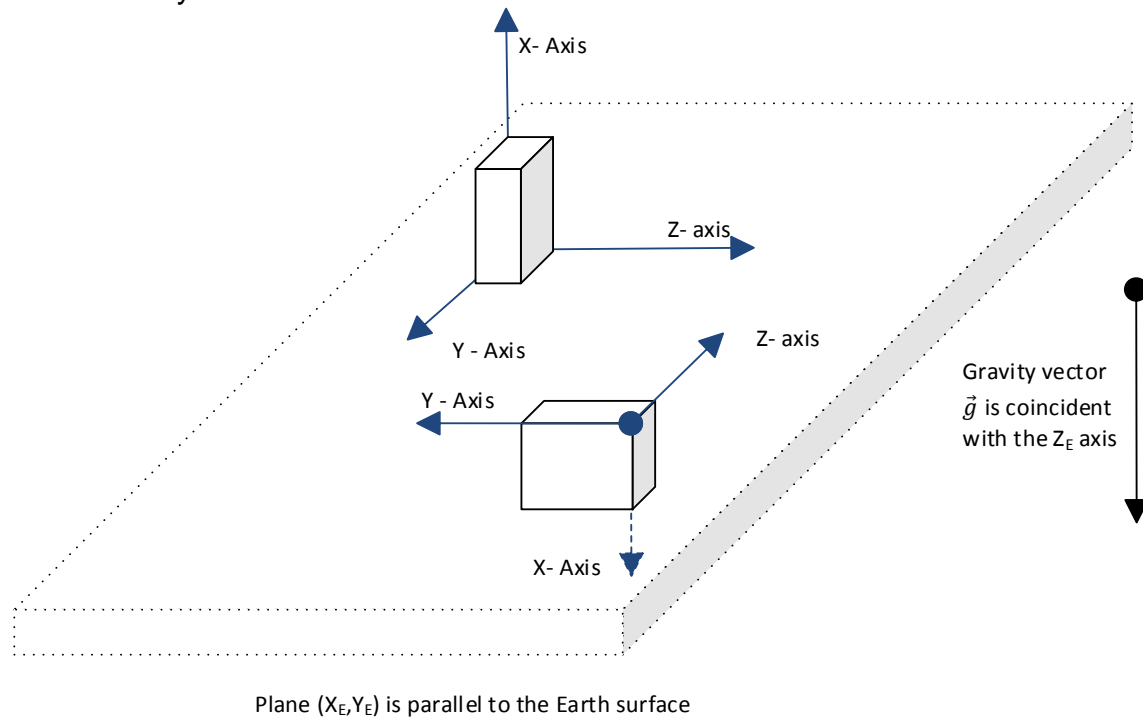

Figure 6. Gimbal Lock

The same condition occurs with the pitch angle θ^u when both: $g_x = g_z = 0$.

The gimbal lock should be avoided in the inclinometer initial installation position. It should be also avoided in the inclinometer working range when it leads to unstable angular measurements.

The user can avoid the gimbal lock condition by changing orientation of the unit frame (a coordinate system attached to the unit) using configuration parameters when necessary.

2.1.3.3 Maximum Gravity Acceleration Error

All angular measurements are based on the assumption that the only acceleration applied to the unit is the gravity acceleration \vec{g} , see (2). This is not entirely true when the inclinometer is installed on a moving machine and is experiencing various external accelerations. These accelerations will affect the angular calculations and, at some point, will make the accuracy of the calculations unacceptable.

To monitor the validity of the angular calculations, the inclinometer is calculating the *Gravity Acceleration Error* δ_g as a difference between the measured gravity acceleration \vec{g} and its expected value:

$$\delta_g = \left| 1 - \sqrt{g_x^2 + g_y^2 + g_z^2} \right| \quad (9)$$

When the difference exceeds a predefined value $\delta_g > \delta_g^{(max)}$, the angular calculations are considered invalid and the inclinometer sets the error state in the [Angular Figure of Merit](#).

The *Maximum Gravity Acceleration Error* $\delta_g^{(max)}$ is set by the user normally above the expected external accelerations at the customer site during normal operation conditions.

Please remember that even when $\delta_g \leq \delta_g^{(max)}$, the rated inclinometer static parameters including accuracy are not guaranteed during external accelerations. The $\delta_g^{(max)}$ only sets a threshold to notify the user that the external accelerations are too high for the angular measurements.

2.1.3.4 Practical Recommendations

In the beginning, the user defines an inclinometer position on the machine, direction of the measurement angle or two angles in orthogonal directions, and the angular ranges.

It is important to understand that the inclinometer calculates angles based on the gravity acceleration and the angles are measured between the inclinometer unit frame or machine frame and the Earth absolute reference frame (X_E, Y_E, Z_E) where the gravity acceleration vector is uniquely defined.

The inclinometer can measure only pitch θ and roll ϕ angles. It cannot measure the yaw angle ψ , since the yaw angle is in the plane perpendicular to the gravity acceleration in the Earth absolute reference frame (X_E, Y_E, Z_E) and therefore cannot be detected by an accelerometer.

The user starts with aligning the inclinometer unit frame with the Earth absolute reference frame at the inclinometer expected position on the machine. This is done by pointing the unit frame Z-axis down, making it coincident with the gravity acceleration vector, and then aligning the unit pitch θ and roll ϕ angles with the required measurement angles. The user can do this either by mechanically rotating the inclinometer housing on the machine or by changing the unit frame orientation using inclinometer configuration parameters.

The vertical mount inclinometer modifications can be also used if the inclinometer housing is installed in the vertical position on the machine.¹

¹ The vertical mount inclinometer modifications are the legacy products that were designed for a vertical inclinometer installation in the past when the unit frame orientation was not configurable. Starting from V5.0 firmware, they do not have any advantages over the regular (horizontal mounting) inclinometers with the unit frame orientation configured for the vertical installation.

After the inclinometer position and the unit frame orientation are defined, the user should choose the type of the angles, since both: tilt and rotation angles have their pros and cons for angular measurements.

Table 1. Tilt and Rotation Angles

Inclination Angles	Advantages	Disadvantages
Tilt, $\pm 90^\circ$ Range	<ul style="list-style-type: none"> Numerically stable in the whole angular range Smooth angular transition inside the measurement range 	<ul style="list-style-type: none"> $\pm 90^\circ$ range for pitch and roll angles No roll-over detection
Tilt, $\pm 180^\circ$ Range	<ul style="list-style-type: none"> Numerically stable in the whole angular range $\pm 180^\circ$ range for pitch and roll angles Roll-over detection 	<ul style="list-style-type: none"> Abrupt angular transition inside the measurement range in roll-over points
Unit Rotation Angles	<ul style="list-style-type: none"> Smooth angular transition inside the measurement range, except for the gimbal lock points. $\pm 180^\circ$ range for pitch and roll angles Roll-over detection 	<ul style="list-style-type: none"> Numerically unstable pitch and roll angles in gimbal lock points
Euler Angles	<ul style="list-style-type: none"> Smooth angular transition inside the measurement range, except for the roll angle in gimbal lock points $\pm 180^\circ$ range for the roll angle Roll-over detection Uniquely define the unit angular position in space 	<ul style="list-style-type: none"> $\pm 90^\circ$ range for pitch angle to avoid ambiguity in angular rotations Numerically unstable roll angle in gimbal lock points

For single and dual-axis measurements, when the measurement range is not above $\pm 90^\circ$, the tilt angles in the $\pm 90^\circ$ range are recommended, see Figure 7 and Figure 8. They are numerically stable and have a smooth angular transition inside the measurement range. If necessary, a roll-over can be monitored by the gravity angle.

For single-axis measurements, when the measurement range is above $\pm 90^\circ$, the rotation angles are recommended. For unit rotation angles, either pitch or roll angle can be used depending on the position of the unit on the machine. For Euler angles, the roll angle can be used, since it covers the entire $\pm 180^\circ$ range.

For dual-axis measurements with the measurement range above $\pm 90^\circ$, both: tilt angles in the $\pm 180^\circ$ range or rotation angles can be used, see Figure 8. If a smooth angular transition inside the measurement range is not necessary, the tilt angles in the $\pm 180^\circ$ range are recommended due to their numerical stability in the whole measurement range.

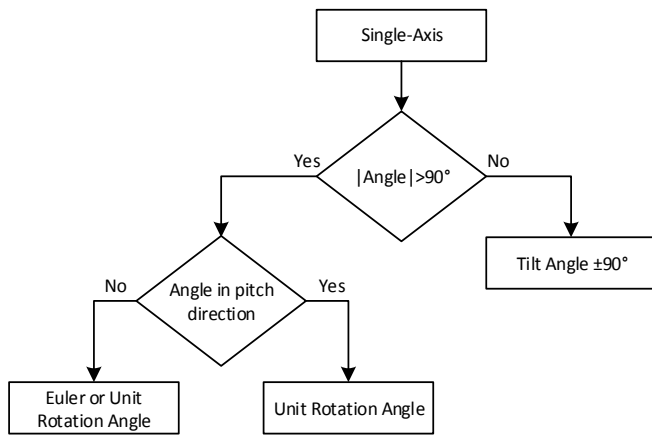

Figure 7. Single-Axis Measurements

In case it is necessary to get the $\pm 180^\circ$ range for both: pitch and roll angles with a smooth angular transition, the unit rotation angles should be used. Otherwise, the Euler angles are preferred, since they have a gimbal lock only for the roll angle, the pitch angle is numerically stable in the whole measurement range.

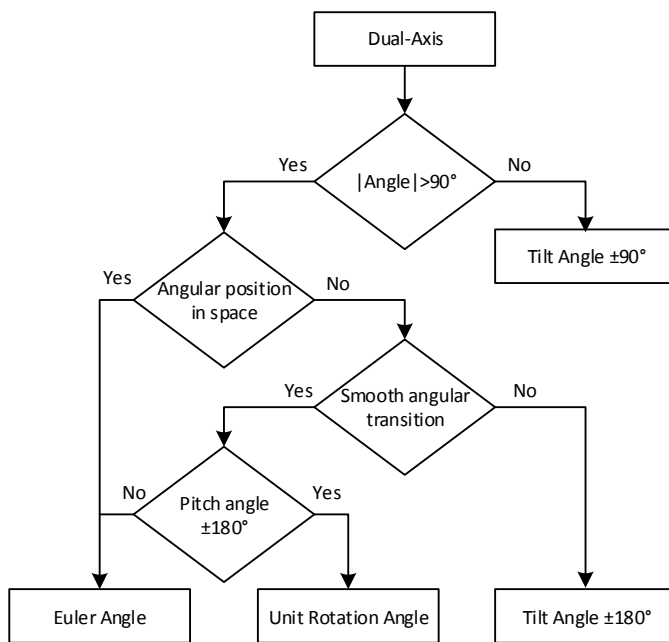

Figure 8. Dual-Axis Measurements

The Euler angles are the angles of choice when it is necessary to determine the unit angular position in space. The yaw angle is then resolved by an external magnetic or GPS sensor.

Even when the Euler angles are not used to calculate pitch and roll angles, they are still used internally to compensate the unit initial installation angles.

2.1.3.5 Default Settings

Inclinometers: AX060800, AX060830, AX061000, AX060806, AX060810, AX060807, AX060811 measure tilt angles in the $\pm 90^\circ$ range by default¹.

The legacy vertical mounting modifications: AX060808, AX060838, originally designed for single-axis measurements in the roll angular direction, measure Euler angles by default.

¹ *Inclinometers with V1.xx firmware measure tilt angles in the $\pm 180^\circ$ range by default.*

2.2 Hardware Block Diagram

The inclinometer contains a three-axis MEMS accelerometer, which senses acceleration in three orthogonal directions: X, Y, and Z.

The outputs of MEMS accelerometer are processed by a 32-bit microcontroller to calculate the unit accelerations and inclination angles. The inclination angles are then output to CAN bus together with all other necessary information, see Figure 9.

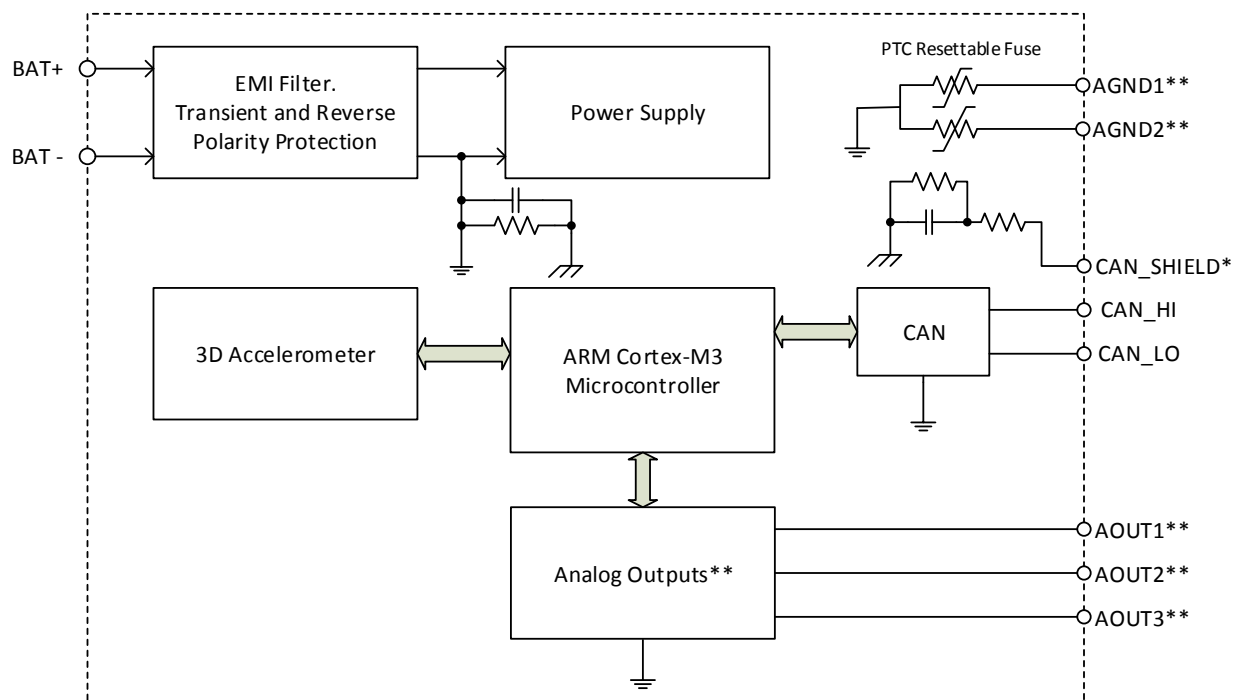

*CAN_SHIELD is absent in AX060806 and AX060807 units.

**Analog Outputs block and AOUT1...3, AGND1...2 are present only in AX061000 units.

Figure 9. The Inclinometer Hardware Block Diagram

The inclinometer has a wide range of protection features including a transient and reverse polarity protection, see [Technical Specifications](#) section.

2.3 Software Organization

The Tri-Axial J1939 CAN Inclinometer belongs to a family of Axiomatic smart controllers with configurable internal architecture. This architecture allows building a controlling algorithm based on a set of predefined internal configurable function blocks without the need of custom software.

The user can configure the inclinometer structure and function blocks using PC-based Axiomatic Electronic Assistant® (EA) software through CAN interface, without disconnecting the inclinometer from the user's system.

The inclinometer application firmware can be updated the same way using EA in the field, see [Flashing New Firmware](#) section.

2.4 CAN Interface

The inclinometer CAN interface is compliant with Bosch CAN protocol specification, Rev.2.0, Part B, and the following J1939 standards:

Table 2. J1939 Standard Support

ISO/OSI Network Model Layer	J1939 Standard
Physical	J1939/11 – Physical Layer, 250K bit/s, Twisted Shielded Pair. Rev. SEP 2006 J1939/15 - Reduced Physical Layer, 250K bits/sec, Un-Shielded Twisted Pair (UTP). Rev. AUG 2008 J1939/14 - Physical Layer, 500 Kbps. Rev. OCT 2011 J1939/16 – Automatic Baud Rate Detection Process. Rev. NOV 2018
Data Link	J1939/21 – Data Link Layer. Rev. DEC 2006 The inclinometer supports Transport Protocol for Commanded Address messages (PGN 65240), ECU identification messages -ECUID (PGN 64965), and software identification messages -SOFT (PGN 65242). It also supports responses on PGN Requests (PGN 59904). Please note that the Proprietary A PGN (PGN 61184) is taken by Axiomatic Simple Proprietary Protocol and is not available for the user.
Network	J1939, Appendix B – Address and Identity Assignments. Rev. FEB 2010 J1939/81 – Network Management. Rev. MAR2017 The inclinometer is an Arbitrary Address Capable ECU. It can dynamically change its network address in real-time to resolve an address conflict with other ECUs. The inclinometer supports: Address Claimed Messages (PGN 60928), Requests for Address Claimed Messages (PGN 59904) and Commanded Address Messages (PGN 65240).
Transport	N/A in J1939
Session	N/A in J1939
Presentation	N/A in J1939
Application	J1939/71 – Vehicle Application Layer. Rev. SEP 2013 The inclinometer can receive application-specific PGNs with input signals and transmit application-specific PGNs with up to ten output signals. All application-specific PGNs are user-programmable. J1939/73 – Application Layer – Diagnostics. Rev. FEB 2010 Memory access protocol (MAP) support. DM14, DM15, DM16 messages are used by EA to program configuration parameters.

2.4.1 CAN Baud Rate

The inclinometer can operate at J1939 standard 250kbit/s and 500kbit/s baud rates. It can also run at 667kbit/s and at 1Mbit/s – the maximum baud rate supported by the CAN inclinometer hardware.¹

¹ *Inclinometers with firmware V1.xx...6.xx could operate only at 250kbit/s baud rate, and with firmware V7.xx...8.xx – at 250, 500, and 1000 kbit/s (1Mbit/s) baud rates.*

The baud rate selection is performed automatically upon connection to the CAN network using passive and active automatic baud rate detection process described in J1939/16. Once detected, the baud rate is stored in non-volatile memory and used on the next inclinometer power-up.

The baud rate detection can be disabled for permanently installed units to maintain the desired baud rate on the CAN network.

2.4.2 J1939 Name and Address

Before sending and receiving any application data, the inclinometer claims its network address with a unique J1939 Name. The Name fields are presented in the table below:

Table 3. J1939 Name Fields

Field Name	Field Length	Field Value	Configurable
Arbitrary Address Capable	1 bit	1 (Capable)	No
Industry Group	3 bit	3 (Construction Equipment)	No
Vehicle System Instance	4 bit	0 (First Instance)	No
Vehicle System	7 bit	0 (Nonspecific System)	No
Reserved	1 bit	0	No
Function	8 bit	136 (Slope Sensor)	No
Function Instance	5 bit	5 ² – AX060800, AX060806, AX060807, AX060808, AX060830, AX060838, AX060810, AX060811; 7 ² – AX061000.	No
ECU Instance	3 bit	0 (First Instance)	Yes
Manufacturer Code	11 bit	162 (Axiomatic Technologies Corp.)	No
Identity Number	21 bit	Calculated on the base of the microcontroller unique ID	No

² *Axiomatic proprietary values for Tri-Axial J1939 CAN Inclinometers.*

The user can change the inclinometer *ECU Instance* using EA to accommodate multiple units on the same CAN network.

The inclinometer takes its network *ECU Address* from a pool of addresses assigned to self-configurable ECUs. The default address can be changed during an arbitration process or upon receiving a commanded address message. The new address value will be stored in a non-volatile memory and used next time for claiming the network address. The *ECU Address* can also be changed in EA.

2.4.3 Slew Rate Control

The inclinometer has an ability to adjust the CAN transceiver slew rate for better performance on the CAN physical network, see [J1939 Network](#) function block for further details.

2.4.4 Network Bus Terminating Resistors

The majority of inclinometers do not have an embedded 120 Ohm CAN bus terminating resistor. Check the [Technical Specifications](#) section for the particular part number.

If not internally installed, the terminating resistors should be installed externally on both ends of the CAN twisted pair cable according to the J1939/11(15) standards to avoid communication errors.

Even if the length of the CAN network is short and the signal reflection from both ends of the cable can be ignored, at least one 120 Ohm resistor is required for the majority of CAN transceivers to operate properly.

2.5 Default Settings

The inclinometer is shipped with the following pre-configured settings to transmit angular data on the CAN bus.

2.5.1 CAN Interface

By default, the inclinometer angular data is transmitted in a standard PGN:

- *PGN 61481, Slope Sensor Information 2, SSI2¹.*

The inclinometer is also pre-configured the way that it can send data in:

- *PGN 61459, Slope Sensor Information, SSI;*
- *PGN 65256, Vehicle Direction/Speed, VDS;*
- *PGN 64905, Vehicle Direction/Speed 2, VDS2.*

The user should use EA to activate sending the appropriate preconfigured PGNs by changing the *Transmission Enable* configuration parameter from *No* to *Yes*, see [CAN Output Message](#) function block. Any other user-defined PGNs can be configured by EA as well.

¹ In firmware V1.xx, AX060800, AX060806, AX060807 transmit angular data in SSI PGN by default.

2.5.1.1 PGN 61459, Slope Sensor Information, SSI

This PGN provides measurements of the vehicle pitch and roll angles and a measurement of the vehicle pitch rate. It has the following parameters:

Transmission Repetition Rate:	10 ms
Data Length:	8
Default Priority:	3
Parameter Group Number:	61459

Start Position	Length	Parameter Name	SPN
1-2	2 bytes	Pitch Angle	3318

Start Position	Length	Parameter Name	SPN
3-4	2 bytes	Roll Angle	3319
5-6	2 bytes	Pitch Rate	3322
7.1	2 bits	Pitch Angle Figure of Merit	3323
7.3	2 bits	Roll Angle Figure of Merit	3324
7.5	2 bits	Pitch Rate Figure of Merit	3325
7.7	2 bits	Pitch and Roll Compensated	3326
8	1 byte	Roll and Pitch Measurement Latency	3327

Parameter Name: Pitch Angle
 Data Length: 2 bytes
 Resolution: 0.002 deg/bit, -64 offset
 Data Range: -64 to 64.51 deg Operational Range: same as data range
 Type: Measured

Parameter Name: Roll Angle
 Data Length: 2 bytes
 Resolution: 0.002 deg/bit, -64 offset
 Data Range: -64 to 64.51 deg Operational Range: same as data range
 Type: Measured

Parameter Name: Pitch Rate (Not used by the inclinometer. Populated with 0xFFFF)
 Data Length: 2 bytes
 Resolution: 0.002 deg/sec per bit, -64 offset
 Data Range: -64 to 64.51 deg/sec Operational Range: same as data range
 Type: Measured

Parameter Name: Pitch Angle Figure of Merit
 Data Length: 2 bits

Bit 2	Bit 1	
0	0	Pitch angle fully functional. Data is within sensor specification.
0	1	Pitch angle degraded. Data is suspect due to environmental conditions.
1	0	Error
1	1	Not available

Type: Status

Parameter Name: Roll Angle Figure of Merit
 Data Length: 2 bits

Bit 2	Bit 1	
0	0	Roll angle fully functional. Data is within sensor specification.
0	1	Roll angle degraded. Data is suspect due to environmental conditions.
1	0	Error
1	1	Not available

Type: Status

Parameter Name: Pitch Rate Figure of Merit (Not used by the inclinometer. Populated with 11b)
 Data Length: 2 bits

Bit 2	Bit 1	
0	0	Pitch rate fully functional. Data is within sensor specification.

	0	1	Pitch rate degraded. Data is suspect due to environmental conditions.
	1	0	Error
	1	1	Not available
Type:	Status		
Parameter Name:	Pitch and Roll Compensated (Not used by the inclinometer. Populated with 11b)		
Data Length:	2 bits		
	Bit 2	Bit 1	
	0	0	Compensation Off
	0	1	Compensation On
	1	0	Error
	1	1	Not available
Type:	Status		
Parameter Name:	Roll and Pitch Measurement Latency		
Data Length:	1 byte		
Resolution:	0.5 ms/bit, 0 offset		
Data Range:	0 to 125 ms	Operational Range: same as data range	
Type:	Measured		

2.5.1.2 PGN 61481, Slope Sensor Information 2, SSI2

This PGN provides measurements of the vehicle extended pitch and roll angle. It has the following parameters:

Transmission Repetition Rate:	10 ms
Data Length:	8
Default Priority:	3
Parameter Group Number:	61481

Start Position	Length	Parameter Name	SPN
1-3	3 bytes	Pitch Angle Extended Range	4976
4-6	3 bytes	Roll Angle Extended Range	4977
7.1	2 bits	Pitch Angle Extended Range Compensation	4978
7.3	2 bits	Pitch Angle Extended Range Figure of Merit	4979
7.5	2 bits	Roll Angle Extended Range Compensation	4980
7.7	2 bits	Roll Angle Extended Range Figure of Merit	4981
8	1 byte	Roll and Pitch Extended Range Measurement Latency	4982

Parameter Name:	Pitch Angle Extended Range		
Data Length:	3 bytes		
Resolution:	1/32768 deg/bit, -250 deg offset		
Data Range:	-250 to 250.9999 deg	Operational Range: same as data range	
Type:	Measured		

Parameter Name:	Roll Angle Extended Range		
Data Length:	3 bytes		
Resolution:	1/32768 deg/bit, -250 deg offset		
Data Range:	-250 to 250.9999 deg	Operational Range: same as data range	
Type:	Measured		

Parameter Name: Pitch Angle Extended Range Compensation (Not used by the inclinometer. Populated with 11b)
 Data Length: 2 bits

Bit 2	Bit 1	
0	0	On
0	1	Off
1	0	Error
1	1	Not available

Type: Status

Parameter Name: Pitch Angle Extended Range Figure of Merit
 Data Length: 2 bits

Bit 2	Bit 1	
0	0	Pitch angle fully functional. Data is within sensor specification.
0	1	Pitch angle degraded. Data is suspect due to environmental conditions.
1	0	Error
1	1	Not available

Type: Status

Parameter Name: Roll Angle Extended Range Compensation (Not used by the inclinometer. Populated with 11b)
 Data Length: 2 bits

Bit 2	Bit 1	
0	0	On
0	1	Off
1	0	Error
1	1	Not available

Type: Status

Parameter Name: Roll Angle Extended Range Figure of Merit
 Data Length: 2 bits

Bit 2	Bit 1	
0	0	Roll angle fully functional. Data is within sensor specification.
0	1	Roll angle degraded. Data is suspect due to environmental conditions.
1	0	Error
1	1	Not available

Type: Status

Parameter Name: Roll and Pitch Extended Range Measurement Latency
 Data Length: 1 byte
 Resolution: 0.5 ms/bit, 0 offset
 Data Range: 0 to 125 ms
 Type: Measured

Operational Range: same as data range

2.5.1.3 PGN 65256, Vehicle Direction/Speed, VDS

Transmission Repetition Rate: On request
 Data Length: 8
 Default Priority: 6
 Parameter Group Number: 65256

Start Position	Length	Parameter Name	SPN
1-2	2 bytes	Compass Bearing	165
3-4	2 bytes	Navigation-Based Vehicle Speed	517
5-6	2 bytes	Pitch	583
7-8	2 bytes	Altitude	580

Parameter Name: Compass Bearing. (Not used by the inclinometer. Populated with 0xFFFF)
 Data Length: 2 bytes
 Resolution: 1/128 deg/bit, 0 offset
 Data Range: 0 to 501.99 deg Operational Range: same as data range
 Type: Measured

Parameter Name: Navigation-Based Vehicle Speed (Not used by the inclinometer. Populated with 0xFFFF)
 Data Length: 2 bytes
 Resolution: 1/256 km/h per bit, 0 offset
 Data Range: 0 to 250.996 km/h Operational Range: same as data range
 Type: Measured

Parameter Name: Pitch
 Data Length: 2 bytes
 Resolution: 1/128 deg/bit, -200 deg offset
 Data Range: -200 to 301.99 deg Operational Range: -200 deg (DECENT) to +301.992 deg (ASCENT)
 Type: Measured

Parameter Name: Altitude (Not used by the inclinometer. Populated with 0xFFFF)
 Data Length: 2 bytes
 Resolution: 0.125 m/bit, -2500 m offset
 Data Range: -2500 to 5531.875 m Operational Range: same as data range
 Type: Measured

2.5.1.4 PGN 64905, Vehicle Direction/Speed 2, VDS2

Transmission Repetition Rate: On request
 Data Length: 8
 Default Priority: 6
 Parameter Group Number: 64905

Start Position	Length	Parameter Name	SPN
1-2	2 bytes	Vehicle Roll	3623

Parameter Name: Vehicle Roll
 Data Length: 2 bytes
 Resolution: 1/128 deg/bit, -200 deg offset
 Data Range: -200 to 301.99 deg Operational Range: -90 to 90 degrees
 Type: Measured

2.5.2 Analog Outputs

Analog Outputs (only in AX061000) are preconfigured as 0...5 V voltage outputs the following way¹:

- AOUT1. Pitch Angle. $-90^\circ \rightarrow 0\text{ V}$, $90^\circ \rightarrow 5\text{ V}$;
- AOUT2. Roll Angle. $-90^\circ \rightarrow 0\text{ V}$, $90^\circ \rightarrow 5\text{ V}$;
- AOUT3. Gravity Angle. $0^\circ \rightarrow 0\text{ V}$, $180^\circ \rightarrow 5\text{ V}$.

¹ In firmware versions 4.xx,...,7.xx, Voltage Range is set to -10...10V, Pitch Angle $-90^\circ \rightarrow -10\text{V}$, $90^\circ \rightarrow 10\text{V}$, Roll Angle $-90^\circ \rightarrow -10\text{V}$, $90^\circ \rightarrow 10\text{V}$, Gravity Angle $0^\circ \rightarrow -10\text{V}$, $180^\circ \rightarrow 10\text{V}$.

The default settings can be changed using EA.

3 INCLINOMETER LOGICAL STRUCTURE

The inclinometer is internally organized as a set of function blocks, which can be individually configured and arbitrarily connected together to achieve the required inclinometer functionality, see Figure 10.

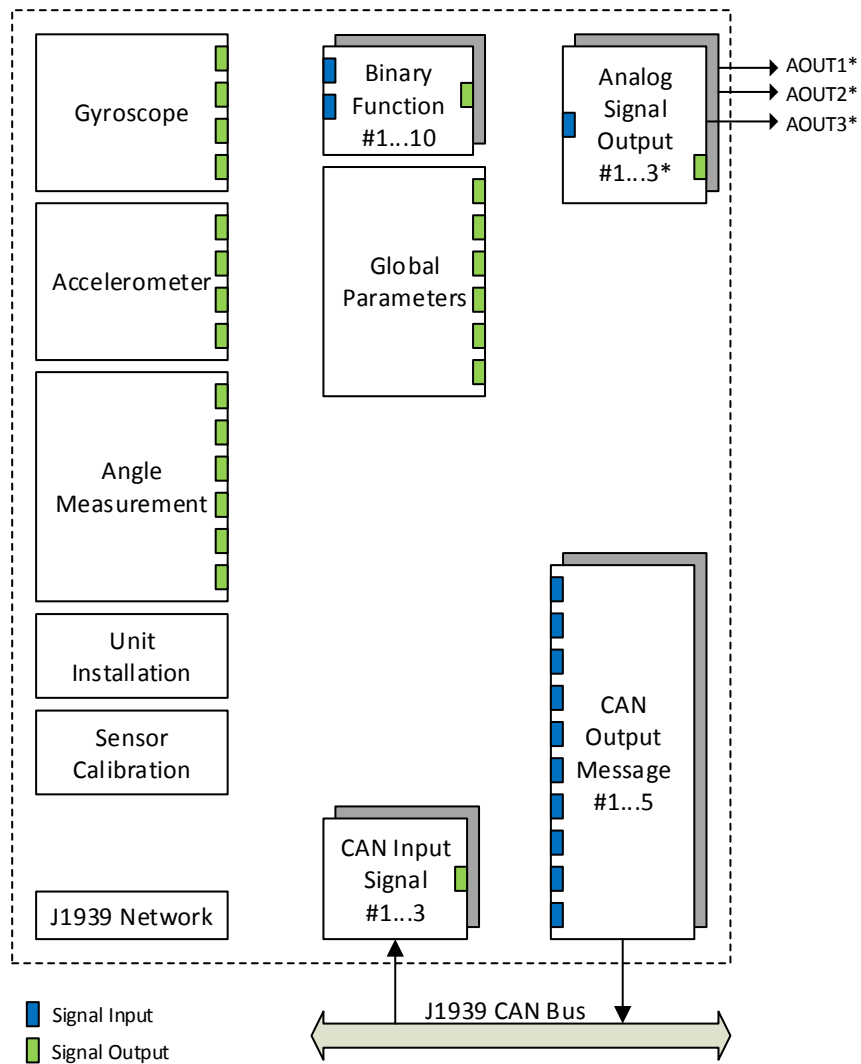

The actual connections between signal inputs and outputs are defined by the configuration parameters.

*Present only in AX061000

Figure 10. The Inclinometer Logical Block Diagram

Each function block is absolutely independent and has its own set of configuration parameters or setpoints. The configuration parameters can be viewed and changed through CAN bus using Axiomatic Electronic Assistant® (EA) software.

The accelerometer sensor is presented by *Accelerometer* function block. *Angle Measurement* function block controls measurements of the inclination angles. *Unit Installation* function block is used to compensate installation angles after the unit is mounted on a machine at a customer site. The user can also change the unit frame orientation using this function block. *Sensor Calibration* is an auxiliary function block presenting the inclinometer calibration parameters.

The J1939 CAN interface is presented by the *CAN Input Signal*, *CAN Output Message* and *J1939 Network* function blocks. The *CAN Input Signal* functional blocks are used to receive CAN signals transmitted on the CAN bus. They have one signal output, which is updated once the signal is received. The *CAN Output Message* function blocks are used to transmit CAN signals on the CAN bus. Each CAN message can hold up to ten individual CAN output signals, which receive data from ten signal inputs.

Configurable analog signal outputs are presented by three independent *Analog Signal Output* function blocks in AX061000.

In case the inclinometer data need to be processed before been output, the unit has ten *Binary Function* blocks to do simple data conversion operations.

The inclinometer also has a *Global Parameters* function block containing four constant output signals and other auxiliary output signals.

3.1 Function Block Signals

The inclinometer function blocks can contain signal inputs and outputs to communicate with each other. Each signal input can be connected to any signal output using an appropriate configuration parameter. There is no limitation on the number of signal inputs connected to a signal output.

When a signal input is connected to a signal output, data from the signal output of one function block is available on the signal input of another function block.

The function block signal data can have the following signal types: *{Undefined, Discrete or Continuous}*.

3.1.1 Undefined Signal

The *Undefined* signal type is used to present a no-signal condition in signal data or to specify that the signal input is not connected (not used).

3.1.2 Discrete Signal

The *Discrete* signal type is used to present a discrete signal that has a finite number of states in signal data or to specify that the signal input or output is communicating this type of signals.

The discrete signals are stored in four-byte unsigned integer variables that can present any state value in the *0...0xFFFFFFFF* range.

3.1.3 Continuous Signal

The *Continuous* signal type presents continuous signals, usually physical parameters, in signal data or as a signal input or output type.

The continuous signals are stored in floating-point variables. They are not normalized and present data in the appropriate physical units. The user can do simple scaling of the continuous signal data by changing *Scale (Resolution)* and *Offset* configuration parameters in the appropriate function blocks.

3.1.4 Signal Type Conversion

Discrete and *Continuous* signals are automatically converted into each other when a signal input of one signal type is connected to a signal output of a different signal type.

3.1.4.1 Discrete to Continuous Conversion

A *Discrete* signal is converted into a positive *Continuous* signal of the same value.

3.1.4.2 Continuous to Discrete Conversion

A positive *Continuous* signal is converted into the same value *Discrete* signal. A fractional part of the *Continuous* signal is truncated. If the *Continuous* signal value is above the maximum *Discrete* signal value, the resulted *Discrete* signal value will saturate to the maximum *Discrete* signal value: `0xFFFFFFFF`.

All negative *Continuous* signals are converted into zero value *Discrete* signals.

3.1.4.3 Undefined Signal Conversion

An *Undefined* signal is not converted into a specific discrete or continuous signal value. It presents a no-signal condition on both: *Discrete* and *Continuous* signal inputs and outputs. The value of an undefined signal is not defined unless a default signal value configuration parameter is used in a function block. In this case, the configuration parameter value is used as a signal value when the signal is not defined, see [Binary Function](#) blocks.

3.2 Accelerometer

The *Accelerometer* function block presents the 3D accelerometer sensor.

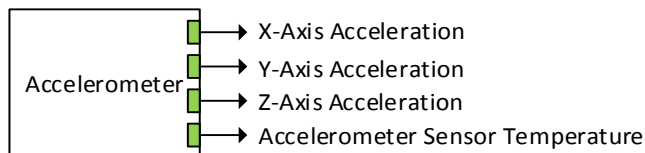

Figure 11. Accelerometer Function Block

The *Accelerometer* function block has four continuous signal outputs. The unit accelerations: *X-Axis Acceleration*, *Y-Axis Acceleration*, *Z-Axis Acceleration* are presented in gravity units [g] in the machine frame, which is coincident with the unit frame by default when the initial pitch and roll angles are zero in the [Unit Installation](#) function block.

The *Accelerometer Sensor Temperature* output presents the sensor temperature in [°C].

In case the inclinometer is used in a high-vibration environment that saturates the acceleration sensor, the sensor can be switched to a higher measurement range to avoid saturation. This feature is available only in inclinometers with a high-performance sensor: AX060830, AX061000, AX060838, AX060810, AX060811.

Keeping the sensor at a higher than default measurement range will increase the sensor output noise and therefore is not recommended in normal conditions.

The *Accelerometer* function block configuration parameters are defined below.

Table 4. *Accelerometer Function Block Configuration Parameters*

Name	Default Value	Range	Units	Description
Input Filter	On	{Off, On}	–	Low-pass input filter
Input Filter Cut-Off Frequency	5	[1...50]	Hz	Cut-Off Frequency when <i>Input Filter</i> is On
Accelerometer Sensor Range ¹	1.5g	{1.5, 3, 6}	g	Accelerometer sensor measurement range

¹ Defined only for inclinometers with a high-performance sensor: AX060830, AX061000, AX060838, AX060810, AX060811. Use sensor ranges above 1.5g only in high-vibration environments. Added in firmware V6.00.

3.3 Angle Measurement

The *Angle Measurement* function block calculates pitch, roll and gravity angles in the machine frame based on the accelerometer sensor output. The machine frame is coincident with the unit frame by default when the initial pitch and roll angles are zero in the [Unit Installation](#) function block.

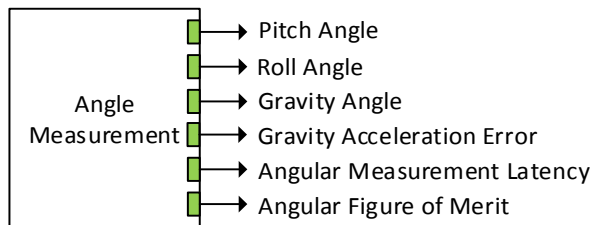

Figure 12. *Angle Measurement Function Block*

The *Pitch Angle* continuous signal output defines the unit pitch angle θ in [deg]. It has ± 90 [deg] range for Euler angles and ± 180 [deg] for unit rotation angles. For tilt angles, it can be either ± 90 or ± 180 [deg] depending on the *Tilt Angle Range* configuration parameter.

The *Roll Angle* continuous signal output defines the roll angle ϕ in [deg]. It has a full ± 180 [deg] range for Euler and unit rotation angles. For tilt angles, it can be either ± 90 or ± 180 [deg] depending on the *Tilt Angle Range* configuration parameter.

The *Gravity Angle* continuous signal output defines the gravity angle ρ in [deg]. It has 0...180 [deg] range.

The *Gravity Acceleration Error* continuous signal output defines the gravity acceleration error δ_g in [g]. When the gravity acceleration error exceeds the *Maximum Gravity Acceleration Error* configuration parameter $\delta_g^{(max)}$, the error state is set in the *Angular Figure of Merit*.

The *Angular Measurement Latency* continuous signal output defines the angular measurement latency in [ms].

The *Angular Figure of Merit* discrete signal output defines whether the angular output data can be trusted. It has the following set of states:

Table 5. Angular Figure of Merit

State	Description
0	Angular data is fully functional. Data is within the sensor specification.
1	Angular data is suspect due to environmental conditions. Set when the accelerometer sensor temperature is less than -40°C or greater than +125°C.
2	Error condition has been detected. The error condition can be due to the sensor malfunction or exceeding the maximum gravity acceleration error.

The *Angle Measurement* function block configuration parameters are presented below.

Table 6. Angle Measurement Function Block Configuration Parameters

Name	Default Value	Range	Units	Description
Pitch and Roll Angle Type	Tilt Angle ¹	{Euler Angle, Tilt Angle, Unit Rotation Angle ² }	–	Type the pitch and roll angle
Tilt Angle Range ³	±90	{±90, ±180}	deg	Tilt angle measurement range
Maximum Gravity Acceleration Error ³	0.2	[0.05...0.5]	g	Maximum gravity acceleration error acceptable for the angular calculations

¹ For AX060808, AX060838 – Euler Angle.

² The Unit Rotation Angle is not supported in firmware V1.xx.

³ Not supported in firmware V1.xx. The Tilt Angle Range is assumed to be ±180° in firmware V1.xx.

3.4 Unit Installation

The *Unit Installation* function block is used to set the unit frame orientation and to compensate the initial installation angles after the unit is mounted on a machine at the customer site.

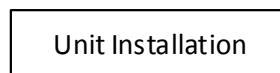

Figure 13. Unit Installation Function Block

The function block has no signal inputs and outputs. Its configuration parameters are presented below.

Table 7. Unit Installation Function Block Configuration Parameters

Name	Default Value	Range	Units	Description
Coordinate Rotation Yaw Angle ¹	0	[-180...180]	deg	Initial unit frame rotation yaw angle
Coordinate Rotation Pitch Angle ¹	0	[-180...180]	deg	Initial unit frame rotation pitch angle
Coordinate Rotation Roll Angle ¹	0	[-180...180]	deg	Initial unit frame rotation roll angle
Initial Pitch Angle	0	[-90...90]	deg	Initial installation pitch angle
Initial Roll Angle	0	[-180...180]	deg	Initial installation roll angle
Auto-Null Command	No ²	{No, Yes}	–	Auto-Null Command. Set <i>Yes</i> to automatically update the <i>Initial Pitch Angle</i> and <i>Initial Roll Angle</i> .

¹ The Coordinate Rotation Yaw, Pitch, and Roll Angles were added in V5.0 firmware.

² The *Auto-Null Command* is not a real configuration parameter. It always returns No value when being read.

The *Coordinate Rotation Yaw, Pitch and Roll Angles* (ψ, θ, ϕ) are used to change the original orientation of the unit frame. The original orientation is shown on the inclinometer label. The coordinate rotation angles are Euler angles applied in the standard yaw-pitch-roll order to the unit frame.

Normally, the coordinate rotation angles are taken in 90-degree increments: 0, ± 90 , ± 180 , but theoretically they can be assigned any value in the $[-180 \dots +180]$ degree range.

After the coordinate system is rotated, the user can install the inclinometer on the machine and set the initial installation pitch and roll angles.

The initial installation pitch and roll angles are Euler angles used to transform the unit accelerations from the unit frame to the machine frame. They can be written manually or set up automatically when *Auto-Null Command* is set to Yes.

To set up the initial installation angles automatically, the user issues the *Auto-Null Command* when the machine is in the initial null-angle position, leveled on the operation area. The machine frame is coincident with the Earth reference frame in this position, see [Unit Reference Frames](#).

The user should avoid the gimbal lock condition when issuing the *Auto-Null Command* since in this case the *Initial Roll Angle* cannot be accurately defined, and the resulting machine frame orientation can be random, see [Gimbal Lock](#).

3.4.1.1 Unit Frame Orientation Examples

The user can change the unit frame orientation by applying the *Coordinate Rotation Yaw, Pitch and Roll Angles* (ψ, θ, ϕ) to the original default orientation of the unit frame.

For example, let us assume that the AX060800 unit in the original null-angle position is placed vertically on the machine, long side up, and the angle of interest will be measured as the unit pitch angle, see Figure 14. Remember, that the measured angle cannot be yaw angle, only pitch or roll angle, see [Practical Recommendations](#).

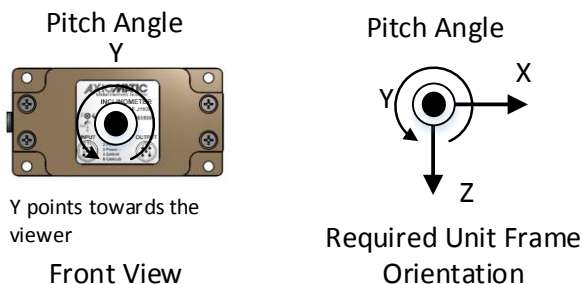

Figure 14. Unit Frame Orientation Example. New Unit Frame Orientation

This assumption will require a new unit frame orientation presented in Figure 14. In the new orientation, the Z-axis points down to be coincident with the gravity vector, the X and Y axes

are rotated the way that the Y-axis points towards the viewer, X-axis points right, and rotation about the Y-axis gives the required pitch angle according to the right-hand rule, see [Unit Coordinate System](#).

To convert the original unit frame orientation into the required one, perform $(0,0,-90^\circ)$ coordinate system rotation, see Figure 15.

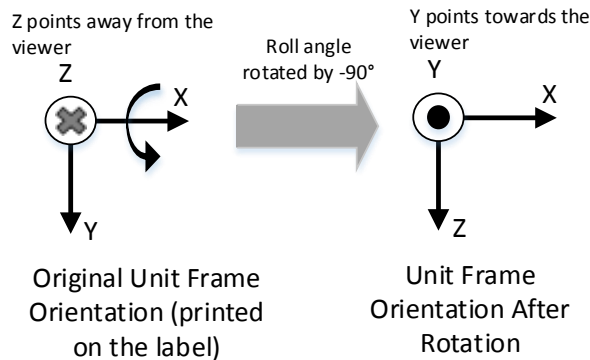

Figure 15. Unit Frame Orientation Example. Coordinate System Rotation

In the same way, a horizontal mounting unit AX060800 can be converted into a vertical mounting unit AX060808 (now legacy p/n), with a different original unit frame orientation, using $(90,90,0)$ coordinate system rotation, see Figure 16.

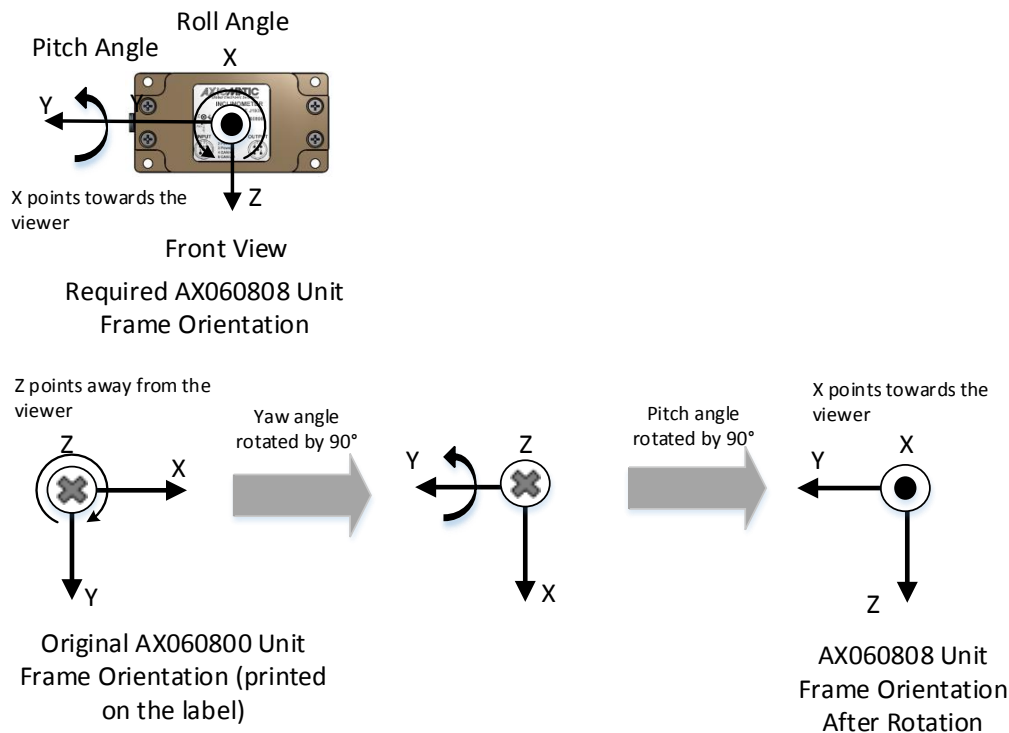

Figure 16. Unit Frame Orientation Example. Conversion AX060800 into AX060808

Do not forget to change the *Pitch and Roll Angle Type* in the *Angle Measurement* function block to *Euler Angle* in this example to get the $\pm 180^\circ$ roll angular range, the default value for AX060808.

In user applications, to avoid errors, it is recommended checking the new unit frame orientation on the bench before installing the inclinometer on the machine. The Axiomatic CAN Assistant – Visual, P/N: AX070501VIS can be used to verify angular directions and ranges after performing the unit frame coordinate rotation.

3.5 Sensor Calibration

The *Sensor Calibration* function block presents internal calibration read-only parameters. It does not have any signal inputs and outputs.

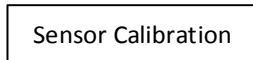

Figure 17. Sensor Calibration

The calibration parameters can be inspected in the field by a qualified technician. They are also written in a setpoint file together with other configuration parameters.

3.6 Binary Functions

There are ten *Binary Function* blocks available to the user for performing simple data conversions. Each *Binary Function* block has two continuous signal inputs and one continuous signal output.

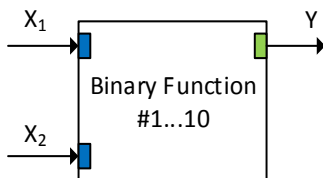

Figure 18. Binary Function Block

The *Binary Function* block performs the following data conversion:

$$Y = A \cdot F[a_1 \cdot f_1(X_1) + b_1; a_2 \cdot f_2(X_2) + b_2] + B, \quad n = 1,2; \quad (10)$$

- where :
- X_n – Input signal;
 - $f_n(X_n)$ – Unary function;
 - a_n – Scale;
 - b_n – Offset;
 - $F[x; y]$ – Binary Function;
 - A – Output Scale;
 - B – Output Offset.

The function block input signals can be undefined. The user can specify a default signal value that will be used when the signal is not defined. If the default signal value is not specified, the output signal of the function block will become undefined too.

The following unary functions can be used to process the input signals.

Table 8. Unary Functions

Function Name	Description	Comment
Undefined	$f(x) = x$	Signal is not processed.
! Logical Not	$f(x) = !x$	x is converted into 4-byte unsigned integer before function is applied.
~ Bitwise Not	$f(x) = \sim x$	x is converted into 4-byte unsigned integer before function is applied.
abs(x) Absolute	$f(x) = x, \text{ if } x \geq 0$ $f(x) = -x, \text{ if } x < 0$	

The following binary functions are defined in the function block:

Table 9. Binary Functions

Function Name	Description	Comment
Undefined	$F[x;y] = \text{Undefined}$	Output signal is undefined.
+ Addition	$F[x;y] = x + y$	
- Subtraction	$F[x;y] = x - y$	
* Multiplication	$F[x;y] = x * y$	
/ Division	$F[x;y] = x / y$	Division by 0 gives 0.
% Modulus	$F[x;y] = x \% y$	x and y are converted into 4-byte unsigned integers before function is applied.
max(x,y) Maximum	$F[x;y] = x, \text{ if } x \geq y$ $F[x;y] = y, \text{ if } x < y$	
min(x,y) Minimum	$F[x;y] = x, \text{ if } x \leq y$ $F[x;y] = y, \text{ if } x > y$	
== Equal	$F[x;y] = 1, \text{ if } x = y$ $F[x;y] = 0, \text{ if } x \neq y$	
!= Not Equal	$F[x;y] = 1, \text{ if } x \neq y$ $F[x;y] = 0, \text{ if } x = y$	
> Great	$F[x;y] = 1, \text{ if } x > y$ $F[x;y] = 0, \text{ if } x \leq y$	
>= Great Equal	$F[x;y] = 1, \text{ if } x \geq y$ $F[x;y] = 0, \text{ if } x < y$	
< Less	$F[x;y] = 1, \text{ if } x < y$ $F[x;y] = 0, \text{ if } x \geq y$	
<= Less Equal	$F[x;y] = 1, \text{ if } x \leq y$ $F[x;y] = 0, \text{ if } x > y$	
Logical OR	$F[x;y] = x \vee y$	x and y are converted into 4-byte unsigned integers before function is applied.
&& Logical AND	$F[x;y] = x \wedge y$	x and y are converted into 4-byte unsigned integers before function is applied.
Bitwise OR	$F[x;y] = x y$	x and y are converted into 4-byte unsigned integers before function is applied.
& Bitwise AND	$F[x;y] = x \& y$	x and y are converted into 4-byte unsigned integers before function is applied.
^ Bitwise XOR	$F[x;y] = x \wedge y$	x and y are converted into 4-byte unsigned integers before function is applied.
<< Left Shift	$F[x;y] = x \ll y$	x and y are converted into 4-byte unsigned integers before function is applied.
>> Right Shift	$F[x;y] = x \gg y$	x and y are converted into 4-byte unsigned integers before function is applied.

The *Binary Function* has the following set of configuration parameters:

Table 10. Binary Function Block Configuration Parameters

Name	Default Value	Range	Units	Description
Binary Function	Undefined	See Binary Function table	–	$F[x;y]$ – Binary function
Output Scale	1	Any value	–	A – Output Scale
Output Offset	0	Any value	–	B – Output Offset
Input #1 Signal Source	Not Connected	Any signal output of any function block or “Not Connected”	–	X_1 – Input Signal #1
Input #1 Signal Default	No	{No, Yes}	–	Defines whether the default signal value for X_1 is defined
Input #1 Signal Default Value	0	Any value	–	X_1 default value, if <i>Input #1 Signal Default</i> is <i>Yes</i>
Unary Function #1	Undefined	See Unary Function table	–	$f_1(x)$ – Unary function #1
Scale #1	1	Any value	–	a_1 – Scale #1
Offset #1	0	Any value	–	b_1 – Offset #1
Input #2 Signal Source	Not Connected	Any signal output of any function block or “Not Connected”	–	X_2 – Input Signal #2
Input #2 Signal Default	No	{No, Yes}	–	Defines whether the default signal value for X_2 is defined
Input #2 Signal Default Value	0	Any value	–	X_2 default value, if <i>Input #2 Signal Default</i> is <i>Yes</i>
Unary Function #2	Undefined	See Unary Function table	–	$f_2(x)$ – Unary function #2
Scale #2	1	Any value	–	a_2 – Scale #2
Offset #2	0	Any value	–	b_2 – Offset #2

3.7 Analog Signal Outputs

There are three independent *Analog Signal Output* function blocks representing analog signal outputs in AX061000.

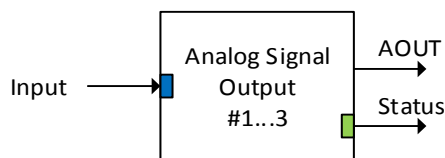

Figure 19. Analog Signal Output Function Block

By default, they are used to output angles but can be configured to output any internal inclinometer signal in the form of voltage or current.

Each *Analog Signal Output* function block has one *Status* signal to output the real-time status of the analog output signal *AOUT*, see Figure 19.

The *Analog Signal Output* has the following set of configuration parameters:

Table 11. *Analog Signal Output Function Block Configuration Parameters*

Name	Default Value ¹	Range	Units	Description
Input Signal Source	Pitch Angle	Any signal output of any function block or "Not Connected"	–	Source of the input signal
Output Mode	Output Voltage	{Disabled, Output Voltage, Output Current}	–	Output mode of the analog signal output
Voltage Range	0...5V ²	{0...5V, 0...10V, -5...5V, -10...10V}	–	Voltage range in the <i>Output Voltage</i> mode
Current Range	4...20mA	{4...20mA, 0...20mA, 0...24mA}	–	Current range in the <i>Output Current</i> mode
Scale	0.02777778 ²	Any Value	V or mA / signal units	Input signal scale
Offset	2.5	Any Value	V or mA	Input signal offset

¹ For *Analog Signal Output* #1.

² *Voltage Range* is set to -10...10V and *Scale* to 0.11111111 in firmware versions 4.xx,...,7.xx.

The output signal value is equal to:

$$AOUT = X \cdot Scale + Offset, \quad \text{where: } X \text{ – input signal from the } Input\ Signal\ Source. \quad (11)$$

Undefined input signals are presented as zero voltage in *Output Voltage* mode. In *Output Current* mode the undefined signals are presented as zero current in 0...20mA and 0...24mA ranges or as 4mA in the 4...20mA range.

If the signal value is above or below the output range, it is clipped to the range value. For example, 12V is output as 10V on the -10...10V or 0...10V range, or as 5V on the -5...5V or 0...5V range.

If the *Output Mode* is set to *Disabled*, the analog output is in a high impedance state and the output signal is undefined.

The analog output *Status* is a discrete signal containing the following error flags:

Table 12. *Analog Signal Output Status Signal Format*

Bit Position	Flag Name	Flag Description
0	Temperature Error	A temperature of the <i>Analog Signal Output</i> converter chip is above permitted. The chip is in the thermal shutdown state.
1	Current Output Error	An open circuit has been detected or the voltage is too high on the analog output in the <i>Output Current</i> mode.
2	Global Error	Internal communication or power supply error
3...31	Reserved	All reserved bits are in the reset (equal to 0) state.

The *Status* bits are enumerated from LSB to MSB starting from 0 (0 – LSB, 31 – MSB). The flags are set (active) when equal to 1 and reset (inactive) – when equal to 0.

All analog signal outputs will be reset to zero voltage or either zero (for 0...20mA, 0...24mA ranges) or 4mA current (for 4...20 mA range) and then re-initialized on the internal communication error on any of the output channels. The *Global Error* flag will be kept set until the normal operation on all signal outputs is restored.

3.8 Global Parameters

The *Global Parameters* functional block gives the user access to a set of global constants, unit supply voltage and the microcontroller internal temperature.

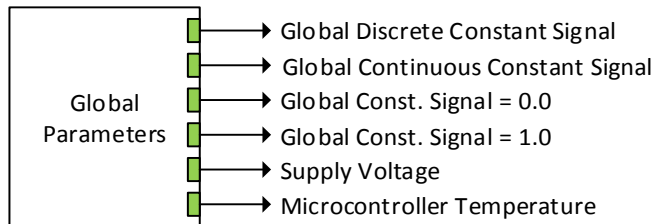

Figure 20. *Global Parameters* Function Block

The function block has one configurable *Global Discrete Constant Signal* output, one configurable *Global Continuous Constant Signal* output and two continuous pre-set constant signal outputs: *Global Const. Signal = 0.0* and *Global Const. Signal = 1.0*.

The function block also contains *Supply Voltage* continuous signal output presenting the inclinometer supply voltage in [V]. Please note, that this voltage is not the voltage on the inclinometer power supply connector pins. It is an internal voltage measured after the EMI filter, reverse polarity, and transient protection circuit. It is always less than the actual power supply voltage by approximately 0.7...0.95 V, except for AX061000 units with analog outputs, where this voltage drop is less than 0.1...0.2V and therefore can be ignored.

The microcontroller internal temperature is presented on the *Microcontroller Temperature* continuous signal output in [°C].

The *Global Parameters* function block has the following configuration parameters.

Table 13. *Global Parameters* Function Block Configuration Parameters

Name	Default Value	Range	Units	Description
Global Continuous Constant Signal	0	Any value	–	Output signal value of the <i>Global Continuous Constant Signal</i>
Global Discrete Constant Signal	0	[0... 4294967295 (0xFFFFFFFF)]	–	Output signal value of the <i>Global Discrete Constant Signal</i>

3.9 J1939 Network

The *J1939 Network* function block defines the global J1939 CAN network settings. It does not have signal inputs and outputs.

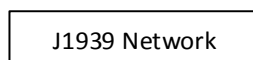

Figure 21. *J1939 Network* Function Block

Configuration parameters of the *J1939 Network* function block are presented below. They contain *ECU Network* and *CAN Network Parameters*.

Table 14. *J1939 Network Function Block Configuration Parameters*

Name	Default Value	Range	Units	Description
ECU Instance Number	0	[0...7]	–	ECU Instance field of the J1939 ECU Name
ECU Address	226	[0...253]	–	J1939 ECU address
Baud Rate ¹	–	{250, 500, 667, 1000} ³	kbit/s	Current baud rate on the CAN network
Automatic Baud Rate Detection ²	Yes	{No, Yes}	–	Set to <i>No</i> once ECU is permanently installed on the CAN network.
Slew Rate	Low	{Low, High}	–	Slew rate control of the CAN transceiver

¹ Read-only parameter. Not available in firmware V1.xx...6.xx.

² Not available in firmware V1.xx...6.xx.

³ Range is {250, 500, 1000} in firmware V7.xx...8.xx.

3.9.1 ECU Network Parameters

The user can change the *ECU Instance Number* and *ECU Address* to adjust the unit on the CAN network.

Changing the *ECU Instance Number* is necessary to accommodate multiple inclinometers on the same CAN network. The list of available ECU instances is shown in the *ECU Instance Number Setup* dialog window in EA. The user should select the required ECU instance number and then press OK or, starting from EA 5.14.103.0, double-click the selected instance number.

The *ECU Address* is automatically adjusted as the result of an address arbitration process on the J1939 CAN network. It can also be changed by a commanded address message. The user can also manually change the ECU address using the *ECU Address* configuration parameter.

The user selects the new ECU address from the list of available ECU addresses in the *ECU Address Setup* dialog window similar to the ECU instance number setup dialog. After the required ECU address is selected, the user should press OK button or, starting from EA 5.14.103.0, double-click the selected address.

3.9.2 CAN Network Parameters

The *Baud Rate* read-only configuration parameter shows the current baud rate on the CAN network.

The *Automatic Baud Rate Detection* parameter defines whether the ECU will try to detect the CAN baud rate in case of communication errors. The baud rate is detected from the list of supported CAN baud rates.

To avoid an arbitrary selection of the CAN baud rate by ECUs involved in the automatic baud rate detection process, it is necessary to disable the automatic baud rate detection in ECUs that are already permanently installed on the CAN network.

The *Slew Rate* configuration parameter defines the slew rate of the CAN transceiver the following way:

Table 15. Slew Rates

Slew Rate Value	Transceiver Slew Rate	Note
Fast	19 V/ μ s	Available for all baud rates
Slow	4 V/ μ s	Only available for 250kbit/s baud rate

The user can select the *Slew Rate* only when the inclinometer operates at 250 kbit/s baud rate. For baud rates higher than 250 kbit/s, the *Slew Rate* is always set to *Fast* independently of the *Slew Rate* configuration parameter.

The *Slow* slew rate is preferable at 250 kbit/s baud rate in the majority of applications due to the reduced EMI of the CAN transceiver. The *Fast* slew rate, in this case, is used when the distance between CAN nodes substantially exceeds 40 m – the maximum value defined by the J1939/11(15) standard.

3.10 CAN Input Signal

There are three *CAN Input Signal* function blocks available to the user. Each function block represents one CAN input signal that can be received from the CAN bus. The function block has one signal output with a user-defined signal type.

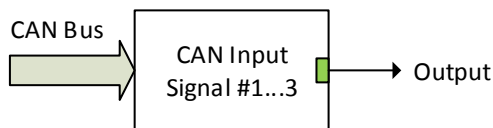

Figure 22. CAN Input Signal Function Block

The *CAN Input Signal* function block reads single-frame application-specific CAN messages and extracts CAN signal data presented in user-defined data format. Different *CAN Input Signal* function blocks can read and process the same CAN message to extract different CAN signal data.

The CAN messages transmitted by the unit itself are also processed by *CAN Input Signal* function blocks. The only difference in processing of the internal messages is that they are not sampled from the CAN bus and therefore their processing does not depend on the state of the bus.

Configuration parameters of the *CAN Input Signal* function block are presented below:

Table 16. CAN Input Signal Function Block Configuration Parameters

Name	Default Value	Range	Units	Description
Signal Type	Undefined	{Undefined, Discrete, Continuous}	–	CAN input signal type
PGN	65535	Any J1939 PGN value ¹	–	Signal message PGN value
PGN From Selected Address	No	{No, Yes}	–	Only CAN messages from the selected address will be accepted, if <i>Yes</i> .
Selected Address	0	[0; 253]	–	Address of the ECU transmitting CAN messages if <i>PGN From Selected Address</i> is set to <i>Yes</i>
Data Position Byte	1	[1; 8]	–	Start byte of the CAN input signal in the CAN message data frame
Data Position Bit	1	[1; 8]	–	Start bit of the CAN input signal in the Data Position Byte
Size	1	[1...32]	bit	CAN input signal size
Resolution	1	Any value	signal units / bit	CAN input signal resolution for continuous input signals
Offset	0	Any value	signal units	CAN input signal offset for continuous input signals
Autoreset Time	500	[0; 10000]	ms	Function block signal output auto-reset time. If <i>Autoreset Time</i> is 0, the auto-reset is disabled.

¹Proprietary A PGN (61184) is excluded. It is taken by Axiomatic Simple Proprietary Protocol and therefore cannot be used in function blocks.

The CAN input signal position is defined within the CAN message data frame by the *Data Position Byte* and *Data Position Bit* configuration parameters the same way as in the J1939 standard. The start and stop bits of the CAN signal in the 64-bit CAN message data frame are calculated using the formulae:

$$StartBit = (DataPositionByte - 1) \cdot 8 + (DataPositionBit - 1), \quad (12)$$

$$StopBit = StartBit + Size - 1, \text{ where: } StartBit, StopBit \in [0 \dots 63].$$

Resolution and *Offset* configuration parameters are set for continuous CAN input signals. They are not used with discrete CAN signals.

The following rules apply when converting the CAN signal data to the function block output signal:

- It is assumed that the CAN signal code with all bits set to 1 represents an undefined signal. The undefined signal is ignored by the function block;
- Discrete signals can take any value except the one reserved for the undefined signal (all bits set to 1);
- Continuous signals can take only values from the range reserved for continuous signals in the J1939 standard. If the CAN signal code is outside of the range reserved for the continuous signal, the signal is ignored.

When the *Autoreset Time* is not equal to 0, the function block will auto-reset the output signal to the undefined state if the output signal has not been updated within the auto-reset time frame by the new CAN message data.

3.11 CAN Output Message

There are five *CAN Output Message* function blocks available to the user. Each function block represents one single frame CAN output message that can be sent on the CAN bus. The message can contain up to ten CAN output signals. Each CAN output signal is presented by its signal input in the function block.

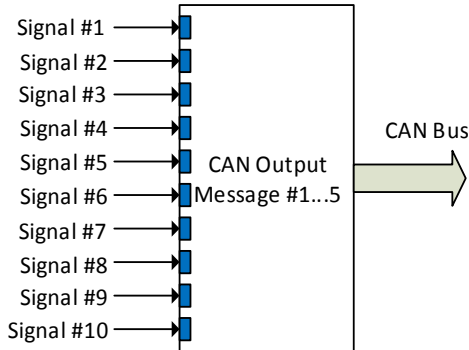

Figure 23. CAN Output Message Function Block

Configuration parameters of the *CAN Output Message* function block are presented below:

Table 17. CAN Output Message Function Block Configuration Parameters

Name	Default Value ¹	Range	Units	Description
PGN	61459	Any J1939 PGN value ³	–	CAN message PGN
Transmission Enable	No ²	{Yes, No}	–	Enables the CAN output message transmission
Transmission Rate	10	[0;10000]	ms	CAN output message transmission rate. If 0 – transmission is upon request.
Destination Address	255	[0; 255]	–	Destination address of the PDU1 PGN messages
Length	8	[0...8]	byte	CAN message data frame length
Priority	3	[0...7]	–	CAN message priority
Signal #1 Type	Continuous	{Undefined, Discrete, Continuous}	–	Type of the 1-st CAN output signal
Signal #1 Source	Pitch Angle	Any signal output of any function block or “Not Connected”	–	Input signal source of the 1-st CAN output signal
Signal #1 Byte Position	1	[1...8]	–	Byte position of the 1-st CAN output signal
Signal #1 Bit Position	1	[1...8]	–	Bit position of the 1-st CAN output signal

Name	Default Value ¹	Range	Units	Description
Signal #1 Size	16	[1...32]	bit	Size of the 1-st CAN output signal
Signal #1 Resolution	0.002	Any value	signal units / bit	Resolution of the 1-st CAN continuous output signal
Signal #1 Offset	-64	Any value	signal units	Offset of the 1-st CAN continuous output signal
Signal #2 Type	Continuous	{Undefined, Discrete, Continuous}	–	Type of the 2-nd CAN output signal
Signal #2 Source	Roll Angle	Any signal output of any function block or “Not Connected”	–	Input signal source of the 2-nd CAN output signal
Signal #2 Byte Position	3	[1...8]	–	Byte position of the 2-nd CAN output signal
Signal #2 Bit Position	1	[1...8]	–	Bit position of the 2-nd CAN output signal
Signal #2 Size	16	[1...32]	bit	Size of the 2-nd CAN output signal
Signal #2 Resolution	0.002	Any value	signal units / bit	Resolution of the 2-nd CAN continuous output signal
Signal #2 Offset	-64	Any value	signal units	Offset of the 2-nd CAN continuous output signal
...
Signal #10 Type	Undefined	{Undefined, Discrete, Continuous}	–	Type of the 10-th CAN output signal
Signal #10 Source	Not Connected	Any signal output of any function block or “Not Connected”	–	Input signal source of the 10-th CAN output signal
Signal #10 Byte Position	1	[1...8]	–	Byte position of the 10-th CAN output signal
Signal #10 Bit Position	1	[1...8]	–	Bit position of the 10-th CAN output signal
Signal #10 Size	1	[1...32]	bit	Size of the 10-th CAN output signal
Signal #10 Resolution	1	Any value	signal units / bit	Resolution of the 10-th CAN continuous output signal
Signal #10 Offset	0	Any value	signal units	Offset of the 10-th CAN continuous output signal

¹ For CAN Output Message #1.

² Yes – in firmware V1.xx for AX060800, AX060806, AX060807.

³ Proprietary A PGN (61184) is excluded. It is taken by Axiomatic Simple Proprietary Protocol and therefore cannot be used in function blocks.

Configuration parameters: *Signal #1...10 Byte Position* and *Signal #1...10 Bit Position*, together with the *Signal #1...10 Size* have the same meaning as in the *CAN Input Signal* function block. The user should be careful not to overlap the output signals.

The following rules apply when converting function block signal data to the CAN output signal code:

- Undefined signals are presented in the signal code with all bits set to 1.
- Discrete signals are directly assigned to the signal code without any conversion.
- Continuous signals are converted to the signal code based on the *Signal #1...10 Resolution* and *Signal #1...10 Offset* configuration parameters. They are saturated to the continuous signal code range defined in the J1939 standard when they go out of range.

4 CONFIGURATION PARAMETERS

The inclinometer configuration parameters can be viewed and changed using the standard J1939 memory access protocol through the CAN network using Axiomatic PC-based Electronic Assistant® (EA) software.

4.1 Electronic Assistant Software

Axiomatic provides PC-based Electronic Assistant® (EA) software to communicate with a wide range of Axiomatic products, including this inclinometer. The software can be downloaded from Axiomatic website www.axiomatic.com.

The EA uses the Axiomatic USB-CAN converter P/N AX070501 to connect to the CAN network. The converter with cables can be ordered as an EA kit P/N AX070502.

Please, refer to the user manual UMAX07050X for description of the EA and associated products, and for the CAN network connection troubleshooting.

The EA software version number supporting all inclinometer configuration parameters is shown on the user manual front page. For example, the user should use EA 5.15.108.0 or higher with the inclinometer application firmware version 9.xx described in this user manual. The most recent EA software version can be downloaded from Axiomatic website.

Before connecting to the CAN network, the user should ensure that the EA baud rate is the same as the baud rate used by ECUs on the network. The EA baud rate is displayed in the bottom-right corner of the EA screen and can be changed in the *Options* menu.

If the inclinometer is the only one ECU on a temporary network set for configuring the unit, the EA baud rate should be set to the baud rate on the CAN network where the inclinometer is planned to be deployed. This baud rate will be stored in the ECU non-volatile memory and used by the unit on the next power-up.

Upon connection, EA will show the inclinometer on the list of ECUs that are present on the J1939 CAN network. If the inclinometer is the only one ECU on the network, the following screen will appear, see Figure 24.

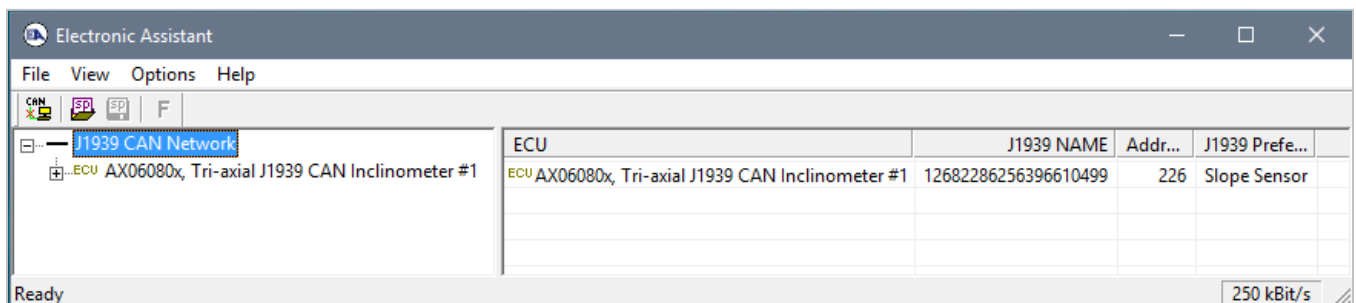

Figure 24. Inclinometer in EA

The user can then browse through the ECU parameters, read *General ECU Information* and *Bootloader Information* groups, view and modify configuration parameters, see Figure 25.

The configuration parameters are grouped by function blocks. Please, refer to the appropriate section of this manual describing the required function block.

In the *General ECU Information* group, the user will see the version number of the application firmware. Please, make sure that the user manual version number matches the most significant part of the application firmware version number. Otherwise, a correct user manual should be used to work with this inclinometer.

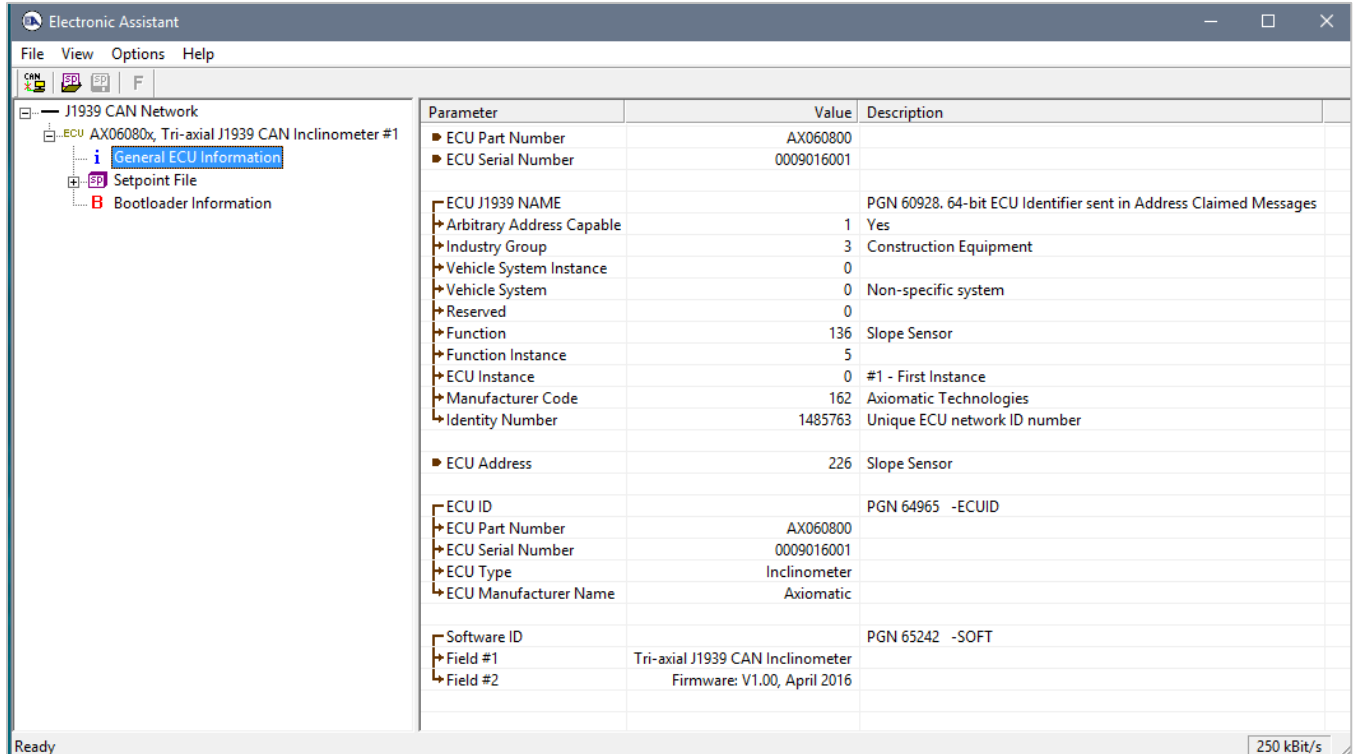

Figure 25. General ECU Information Screen

4.2 Function blocks in EA

Each inclinometer function block is presented by its own setpoint group in the *Setpoint File* main group. Individual configuration parameters (setpoints) of a function block can be accessed through the function block setpoint group, see Figure 26.

The user can view and, when necessary, change configuration parameters by double-clicking on the appropriate setpoint name. A pop-up dialog window will appear, see Figure 27.

If the user changes the configuration parameter, the new value will be stored in a non-volatile memory and used immediately by the inclinometer.

The inclinometer will perform an internal reset of all function blocks after each change of the configuration parameters. If the new configuration parameter affects the CAN network identification, the unit will reclaim its network address with a new network identification message.

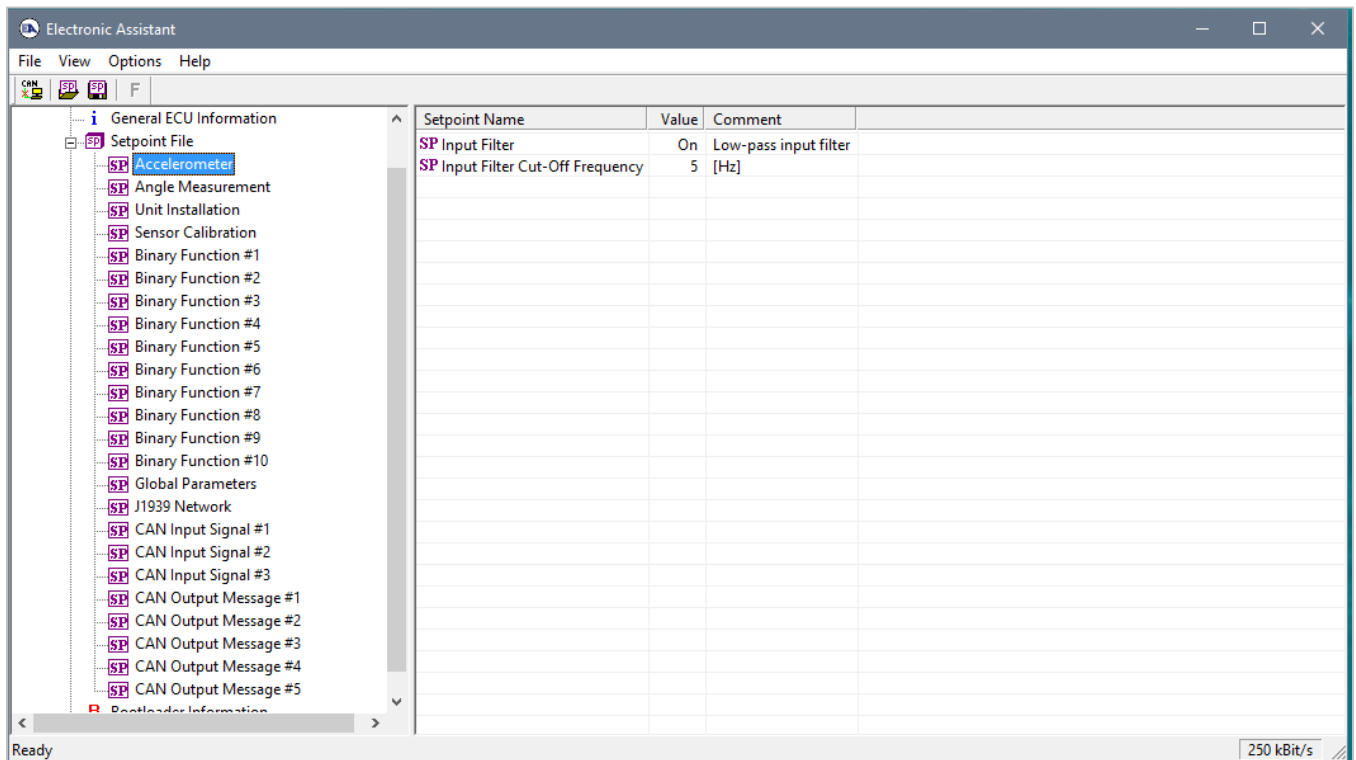

Figure 26. Accelerometer Function Block in EA

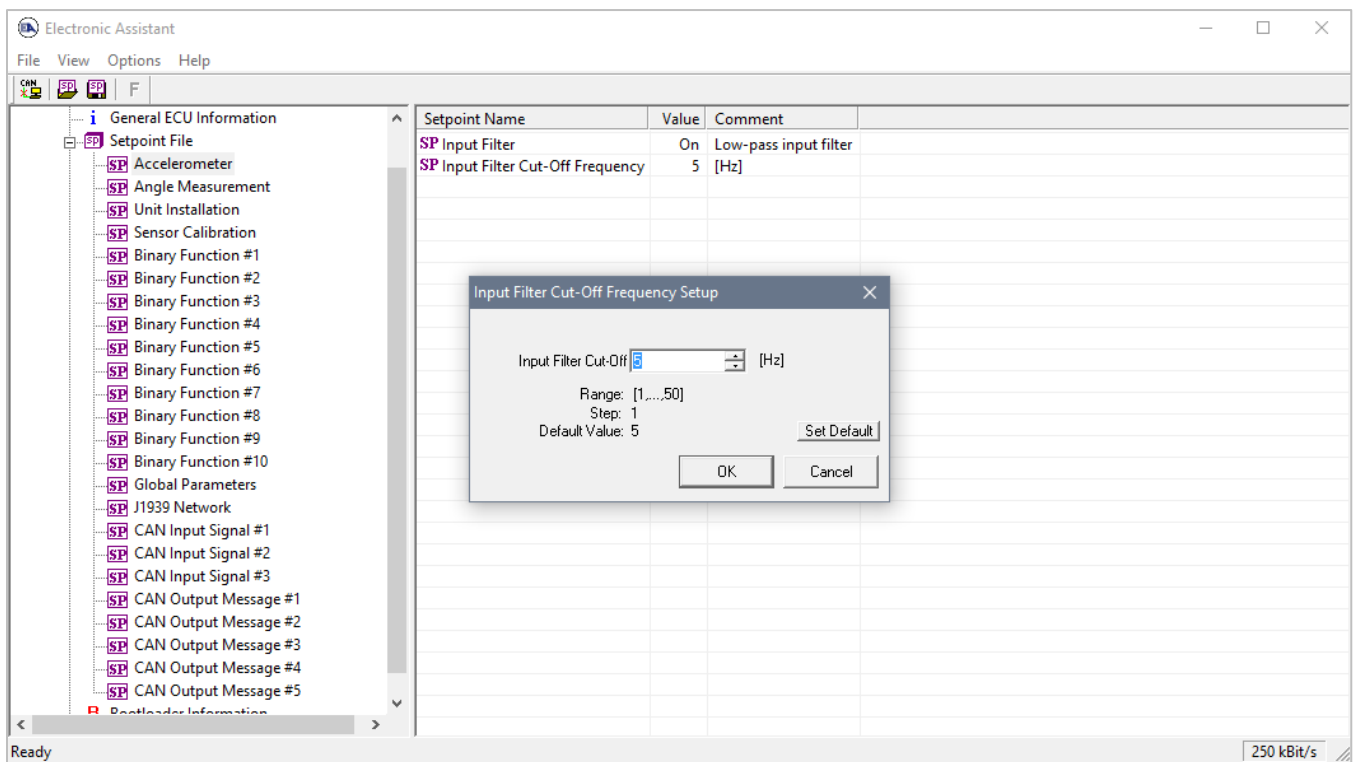
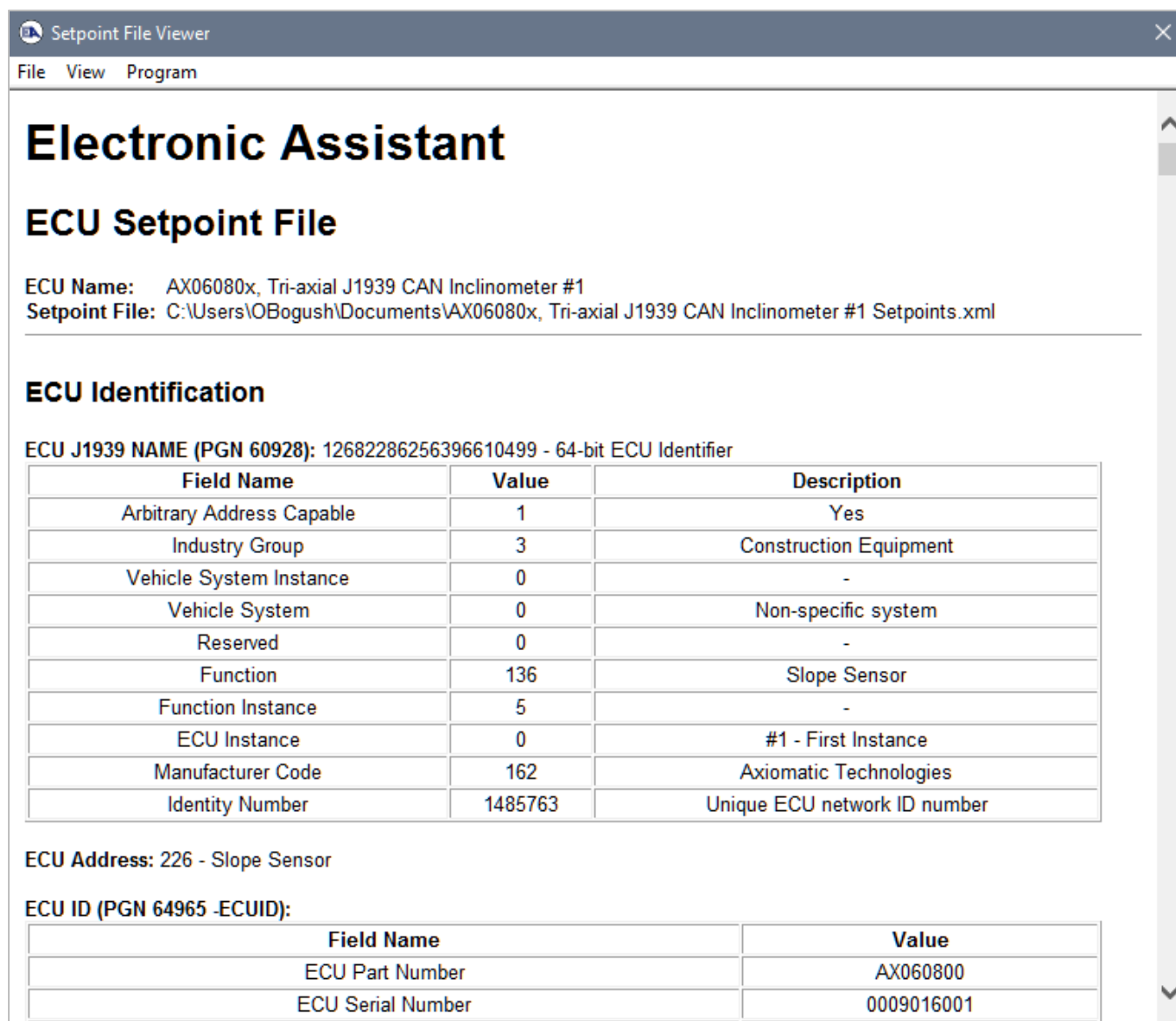

Figure 27. Changing a Configuration Parameter in EA

4.3 Setpoint File

The EA can store all inclinometer configuration parameters in one setpoint file and then flash them into the unit in one operation.

The setpoint file is created and stored on disk using a command *Save Setpoint File* from the EA menu or toolbar. The user then can open the setpoint file, view or print it, and also flash the setpoint file into the inclinometer, see Figure 28.



The screenshot shows the 'Setpoint File Viewer' application window. The title bar reads 'Setpoint File Viewer'. The menu bar contains 'File', 'View', and 'Program'. The main content area displays the following information:

Electronic Assistant

ECU Setpoint File

ECU Name: AX06080x, Tri-axial J1939 CAN Inclinometer #1
Setpoint File: C:\Users\OBogush\Documents\AX06080x, Tri-axial J1939 CAN Inclinometer #1 Setpoints.xml

ECU Identification

ECU J1939 NAME (PGN 60928): 12682286256396610499 - 64-bit ECU Identifier

Field Name	Value	Description
Arbitrary Address Capable	1	Yes
Industry Group	3	Construction Equipment
Vehicle System Instance	0	-
Vehicle System	0	Non-specific system
Reserved	0	-
Function	136	Slope Sensor
Function Instance	5	-
ECU Instance	0	#1 - First Instance
Manufacturer Code	162	Axiomatic Technologies
Identity Number	1485763	Unique ECU network ID number

ECU Address: 226 - Slope Sensor

ECU ID (PGN 64965 -ECUID):

Field Name	Value
ECU Part Number	AX060800
ECU Serial Number	0009016001

Figure 28. EA Setpoint File

The CAN network identification and “read-only” configuration parameters are not transferrable using this operation. Also, the inclinometer will perform one or several internal resets of all function blocks during the setpoint flashing operation.

There can be small differences in configuration parameters between different versions of the application firmware. It is recommended that the user manually inspect all configuration

parameters after flashing if the setpoint file was created by a different version of the application firmware.

A setpoint file containing default configuration parameters is available upon request.

4.4 Configuration Example

The user can change the default inclinometer functionality using the configuration parameters. A detailed description of the unit configuration process is presented below, as an example.

4.4.1 User Requirements

Let us assume that the user requires to generate a proprietary PGN message with a signal flag alarming the user that a platform is tilted more than 30 degrees from its original 0-degree position. The proprietary PGN message parameters are the following:

Transmission Repetition Rate: 100 ms
 Data Length: 1
 Default Priority: 6
 Parameter Group Number: 65280 (PDU2 Proprietary)

Start Position	Length	Parameter Name	SPN
1.1	2 bits	User Alarm Flag	N/A

Parameter Name: User Alarm Flag
 Data Length: 2 bits

Bit 2	Bit 1	
0	0	Off – Platform is not tilted
0	1	On – Platform is tilted
1	0	Error
1	1	Not available

Type: Status

4.4.2 Configuration Steps

As a first step, we need to create a block diagram of the required unit configuration using the function blocks, see Figure 29. Limit our block diagram to the function blocks affected by the new user requirements.

Then configure each individual function block. Start with *Binary Function #1*.

Connect the X_1 input of the *Binary Function #1* to the *Gravity Angle* output of the *Angle Measurement* function block, set X_2 default value to *30 degrees*, and set the *Binary Function F[x,y]* to \geq (*Great Equal*), see Figure 30.

Then configure *CAN Output Message #3* function block to send the proprietary PGN message with the *User Alarm Flag* signal in *Signal #1*.

First, configure the PGN message. Set *PGN* to 65280, *Transmission Enable* to *Yes*, *Transmission Rate* to *100 ms*, *Length* to *1 Byte*, and *Priority* to *6*.

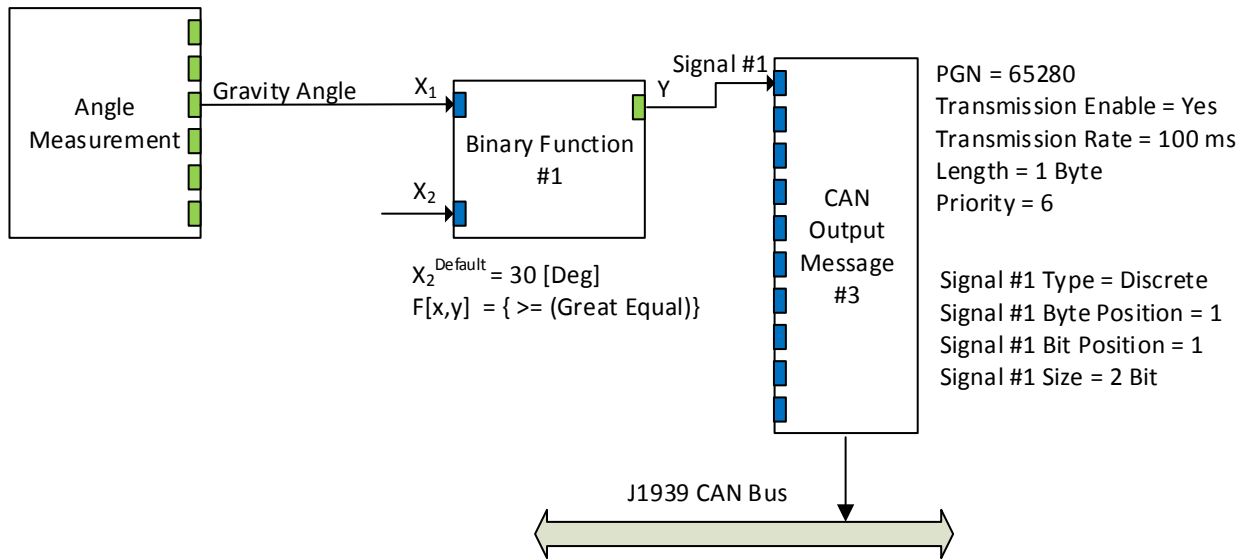

Figure 29. Block Diagram of the Example Configuration

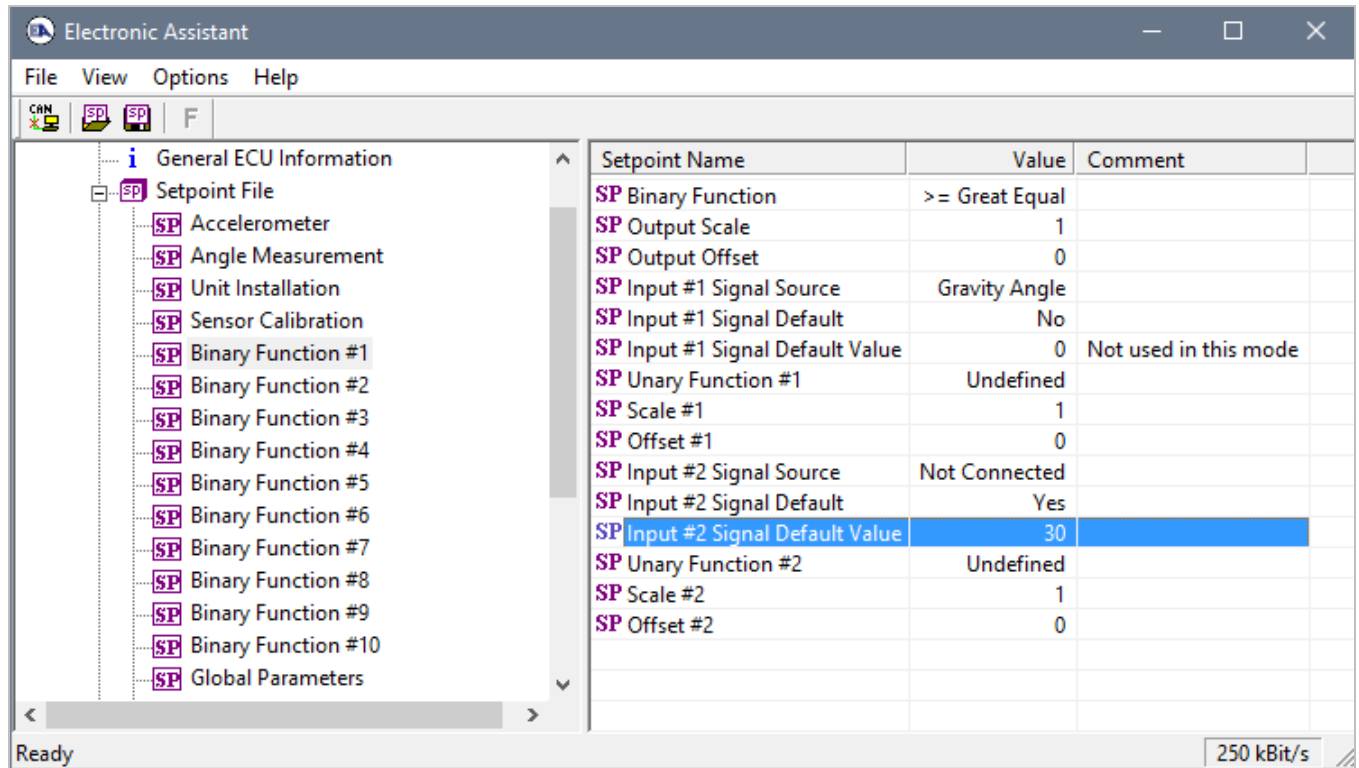

Figure 30. Binary Function #1 Example Configuration

Then, configure CAN Signal #1. Set Signal #1 Type to Discrete, Signal #1 Source to Binary Function #1, Signal #1 Byte Position to 1, Signal #1 Bit Position to 1, and Signal #1 Size to 2 Bits, see Figure 31.

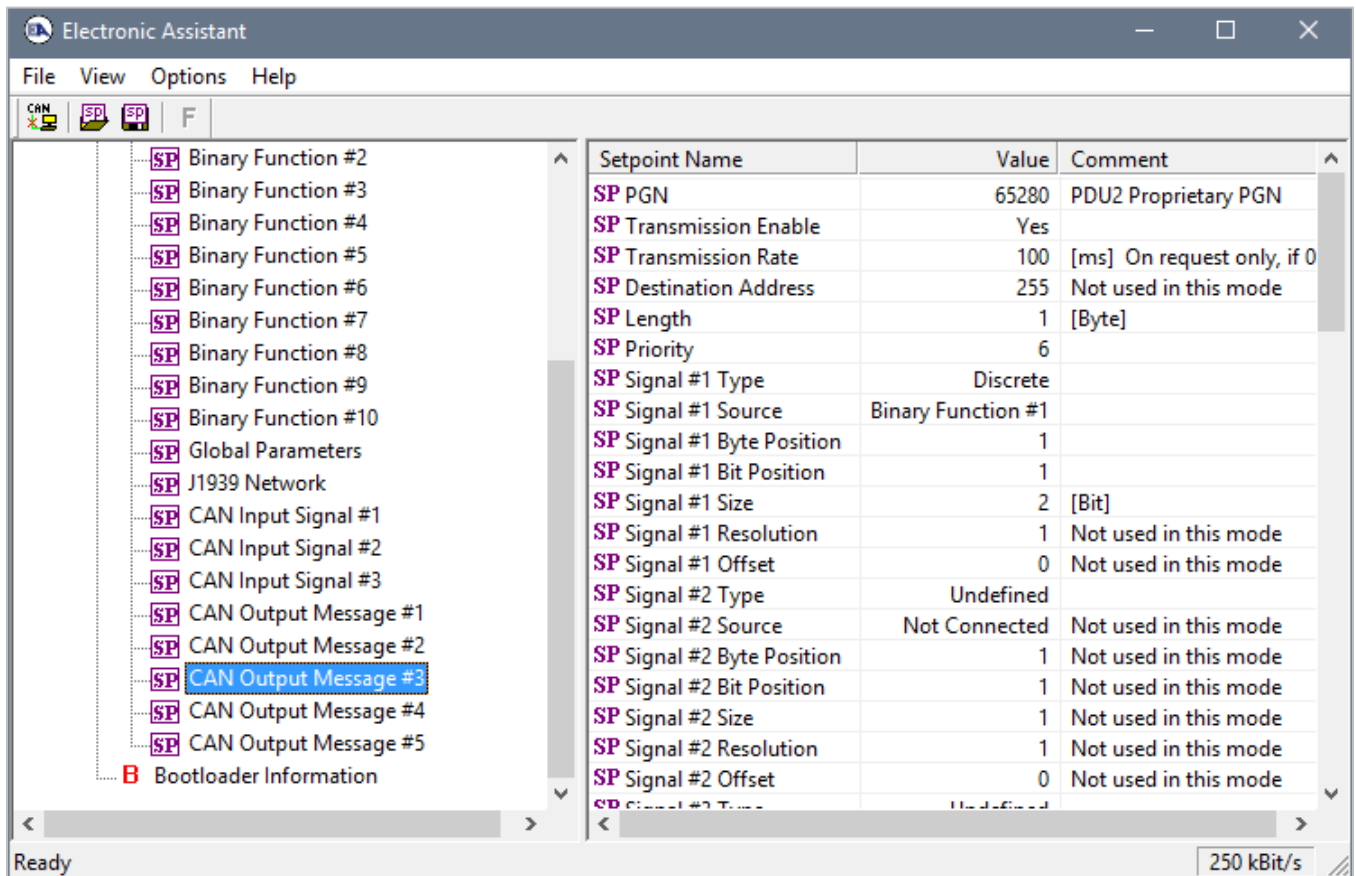

Figure 31. CAN Output Message #3 Example Configuration

As the last step, if the default functionality is not required, the user can disable sending SSI/2 CAN messages in the *CAN Output Message #2* function block by setting the *Transmission Enable* configuration parameter to *No*.

¹ In firmware V1.xx for AX060800, AX060806, AX060807 the user will need to disable SSI CAN messages in the *CAN Output Message #1* function block.

The inclinometer configuration is finished. Now the unit operates according to the new user requirements. The configuration parameters are all set and are already written to the non-volatile unit memory. The users can save them to a setpoint file for future use, if necessary.

The setpoint file for this example is available upon request.

4.4.3 Configuring Analog Signal Outputs

Analog signal outputs of the AX0610000 inclinometer can be used to output any internal inclinometer signals.

For example, let us output the tilt alarm signal described in 4.4.1 as a 5V discrete signal on the analog signal output # 3. Let the signal be described as 0V – Alarm Off and 5V – Alarm On. Other requirements stay the same.

After performing all configuration steps from 4.4.2, we need to configure the *Analog Signal Output #3*. Set *Signal Source* to *Binary Function #1*. This binary function provides the tilt alarm internal signal, see Figure 29. Then set *Output Mode* to *Output Voltage*, *Voltage Range* to *0...5 V*, *Scale* to 5, and *Offset* to 0, see Figure 32.

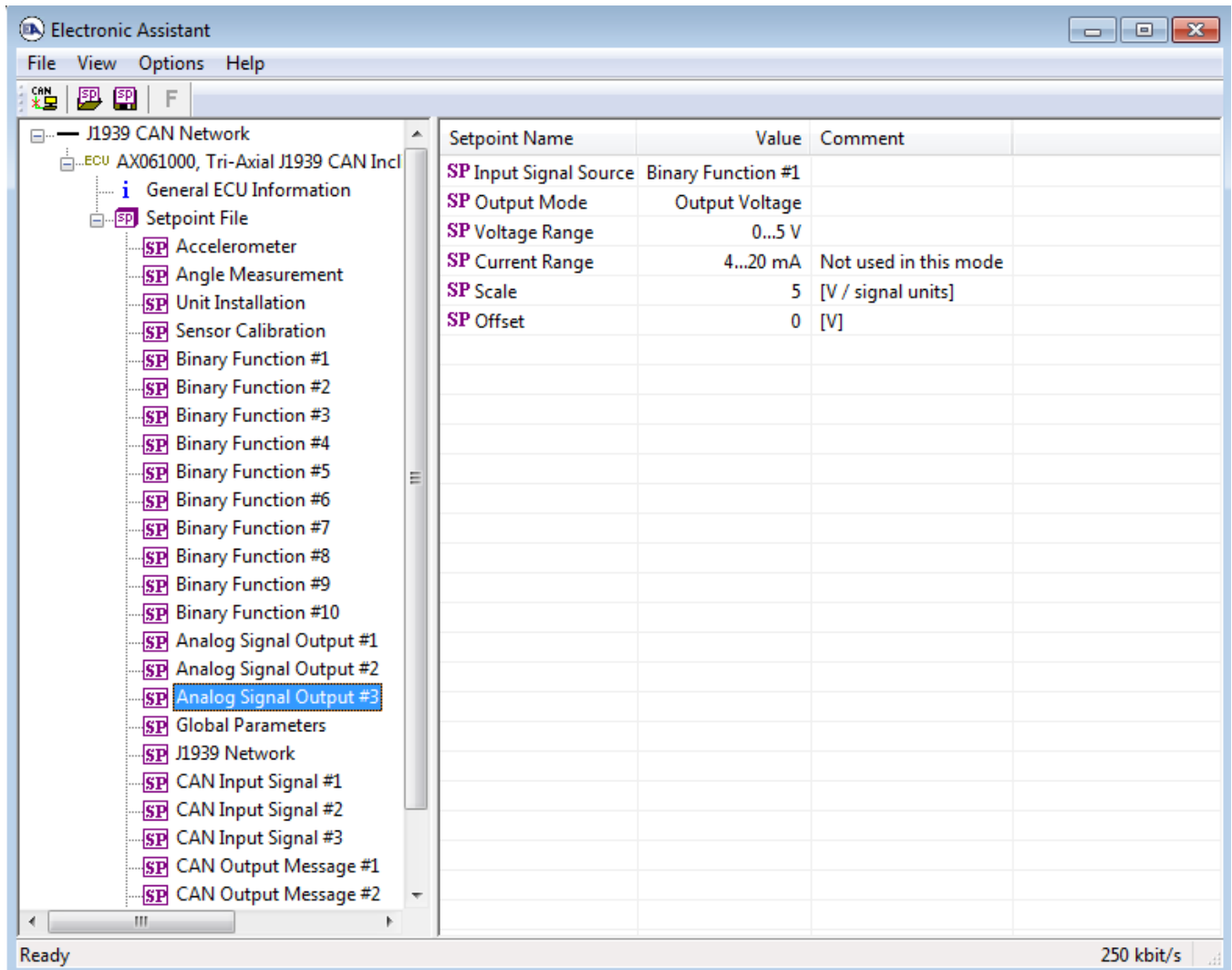

Figure 32. Analog Signal Output #3 Example Configuration

The *Analog Signal Output #3* is now configured. The user can get the tilt alarm signal from the *AOUT3* pin on the inclinometer connector, see Figure 41.

The setpoint file for this example is available upon request.

5 FLASHING NEW FIRMWARE

When the new firmware becomes available, the user can replace the inclinometer firmware in the field using the unit embedded bootloader. The firmware file can be received from Axiomatic on request.

To flash the new firmware, the user should activate the embedded bootloader. To do so, start the EA and in the *Bootloader Information* group screen click on the *Force Bootloader to Load on Reset* parameter. The following dialog will appear, see Figure 33.¹

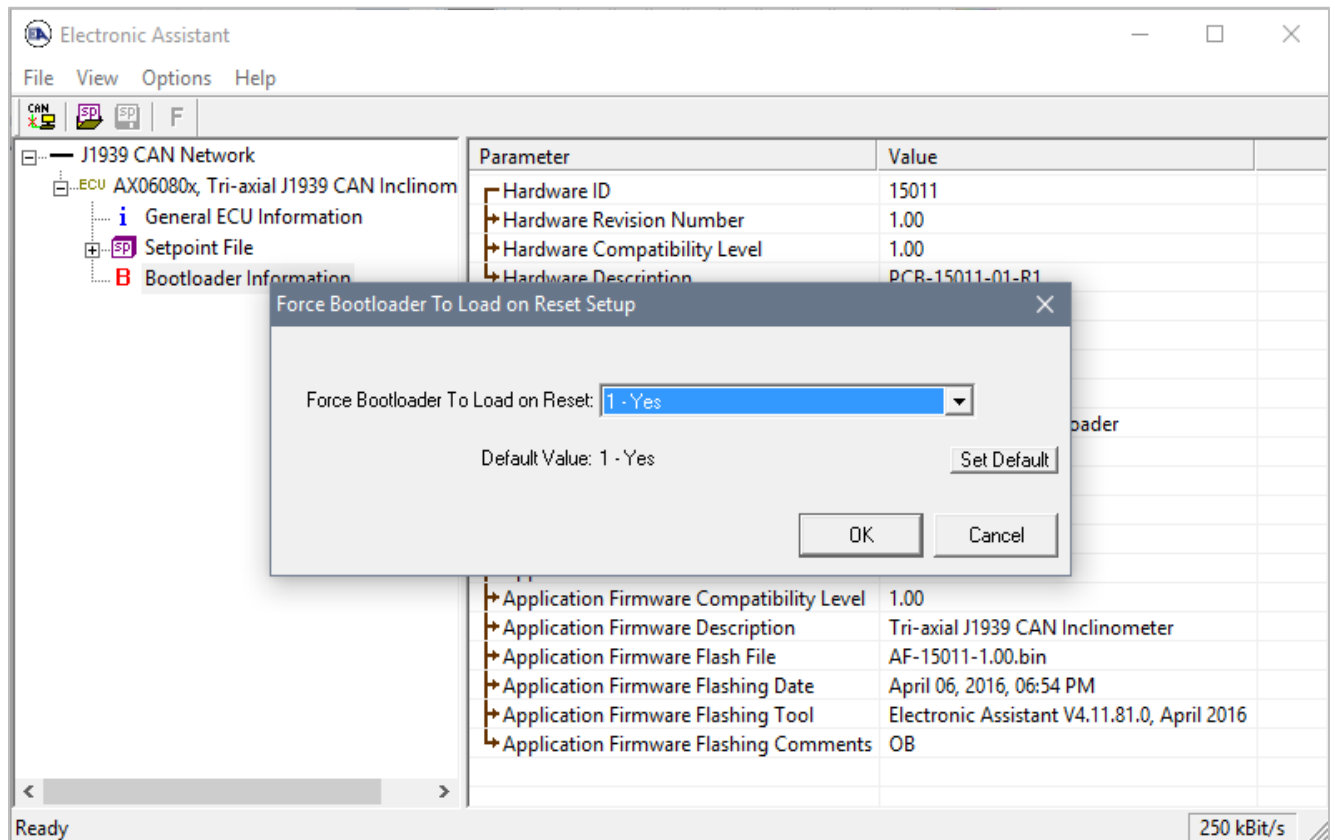

Figure 33. Bootloader Activation. First Step

¹ For bootloader versions 1.xx...3.xx, and 4.xx, originally shipped with older versions of the application firmware, the user should request a special application firmware file compatible with the installed bootloader version to upgrade the inclinometer firmware. The bootloader version can be found on the *Bootloader Information* group screen.

The EA will prompt the user to change the *Force Bootloader to Load on Reset* parameter flag to Yes. This will automatically activate the bootloader on the next ECU reset. After accepting the change, the next screen will ask the user if the reset is actually required, see Figure 34. Select Yes.

After automatic reset, instead of *AX06080x, Tri-Axial J1939 CAN Inclinometer*, the user will see *J1939 Bootloader ECU* in the *J1939 CAN Network* top-level group in the EA. This means that the bootloader is activated and is ready to accept the new firmware.

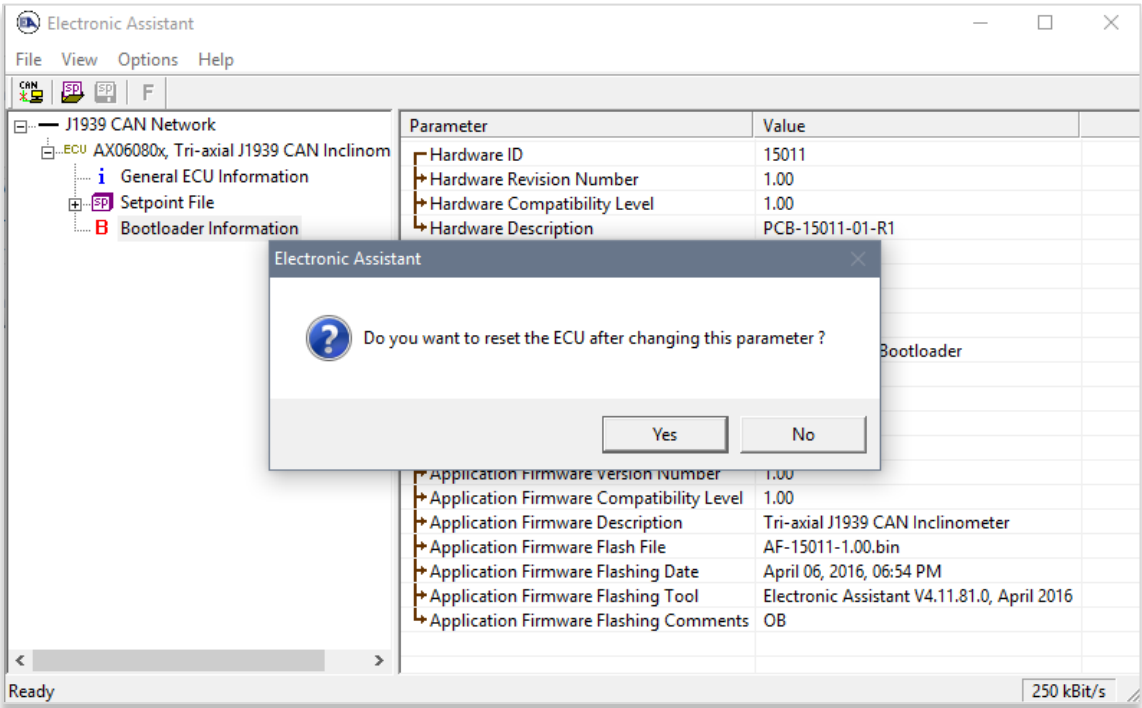

Figure 34. Bootloader Activation. Final Reset

All the bootloader specific information: controller hardware, bootloader details, and the currently installed application firmware remains the same in the bootloader mode and the user can read it in the *Bootloader Information* group screen, see Figure 35. The information can be slightly different for different versions of the bootloader.

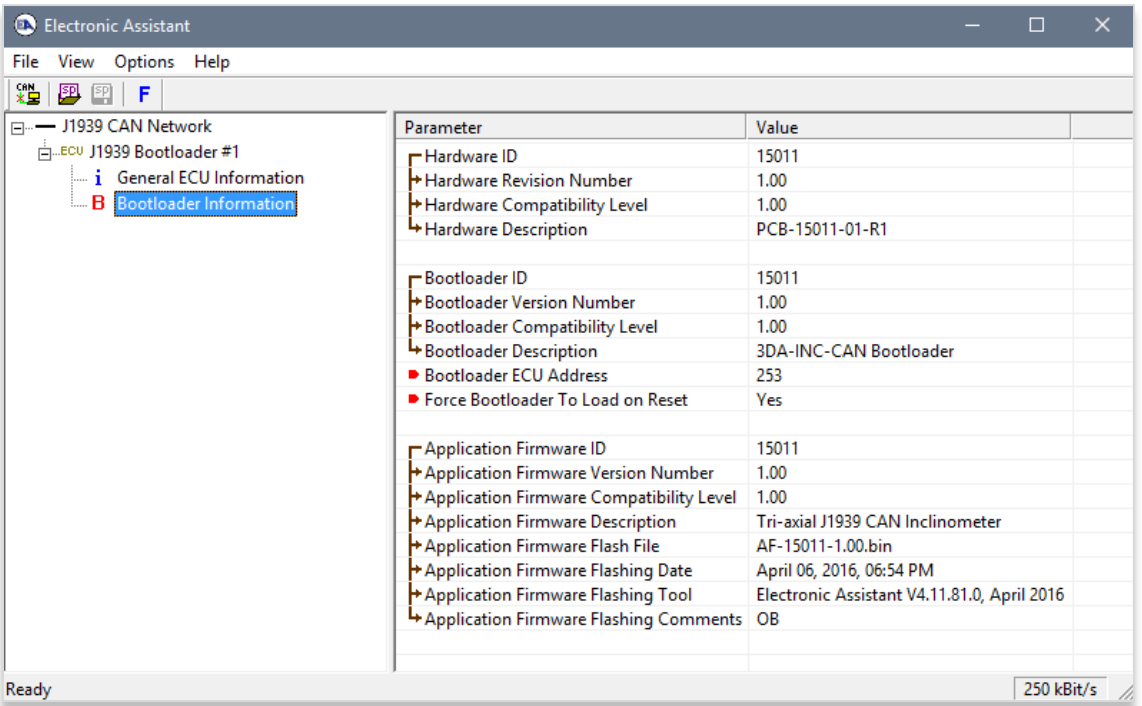

Figure 35. Bootloader Information Screen

At this point, the user can return to the installed controller firmware by changing the *Force Bootloader to Load on Reset* flag back to *No* and resetting the ECU.

To flash the new firmware, the user should click on **F** toolbar icon or from the *File* menu select the *Open Flash File* command. The *Open Application Firmware Flash File* dialog will appear. Pick up the flash file with the new inclinometer firmware and confirm the selection by pressing the *Open* button. The *Flash Application Firmware* dialog window will appear¹, see Figure 36.

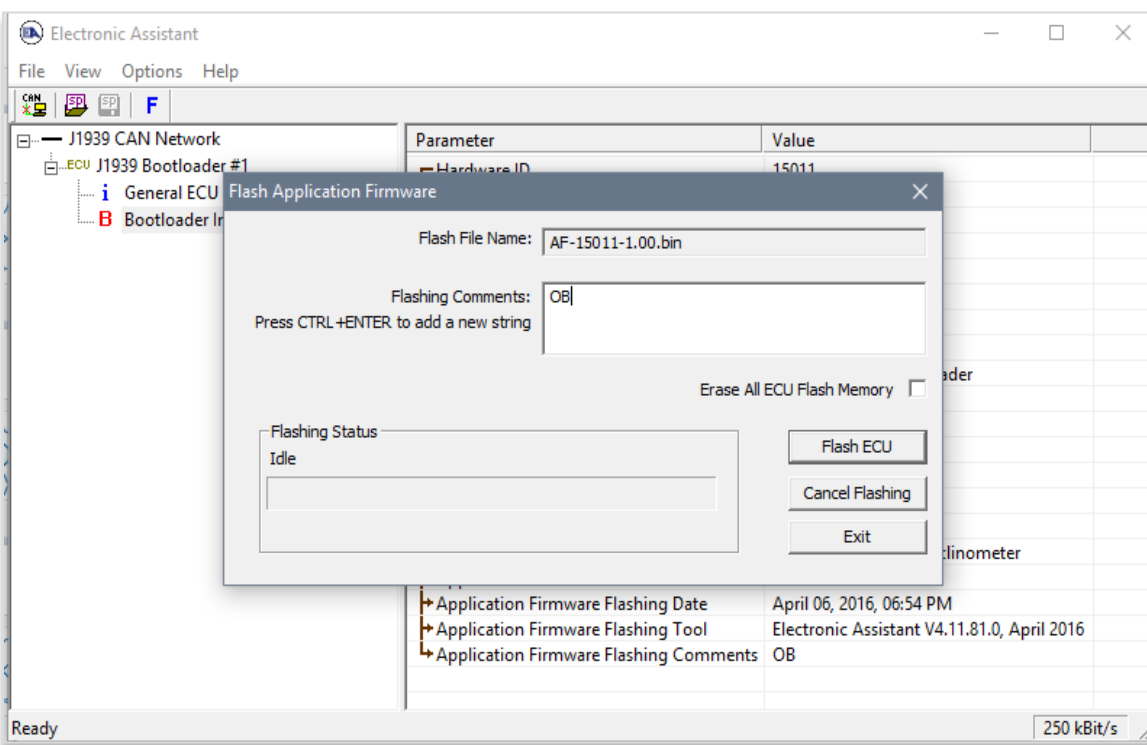

Figure 36. Flashing New Firmware. Preparation

¹ In this example, instead of the new firmware, the old firmware V1.00 is being simply re-flashed.

Now the user can add any comments to the flashing operation in the *Flashing Comments* field. They will be stored in the *Bootloader Information* group after flashing.

The user can also check the *Erase All ECU Flash Memory* flag to erase all configuration parameters set by the old firmware and force the controller to load the default values after flashing the new firmware. Otherwise, the default values will be set only to the new configuration parameters introduced in the new firmware. The old configuration parameters will keep their original values unless otherwise is stated in the user manual.

Select the *Flash ECU* button to start flashing. A reminder that the old application firmware will be destroyed by the flashing operation will appear. Press *Ok* to continue and watch the dynamics of the flashing operation in the *Flashing Status* field. When flashing is done, the following screen will appear prompting the user to reset the ECU, see Figure 37.

Select Yes and see the ECU running the new firmware, see Figure 38. This will indicate that the flashing operation has been performed successfully.

For more information, refer to the *J1939 Bootloader* section of the EA user manual.

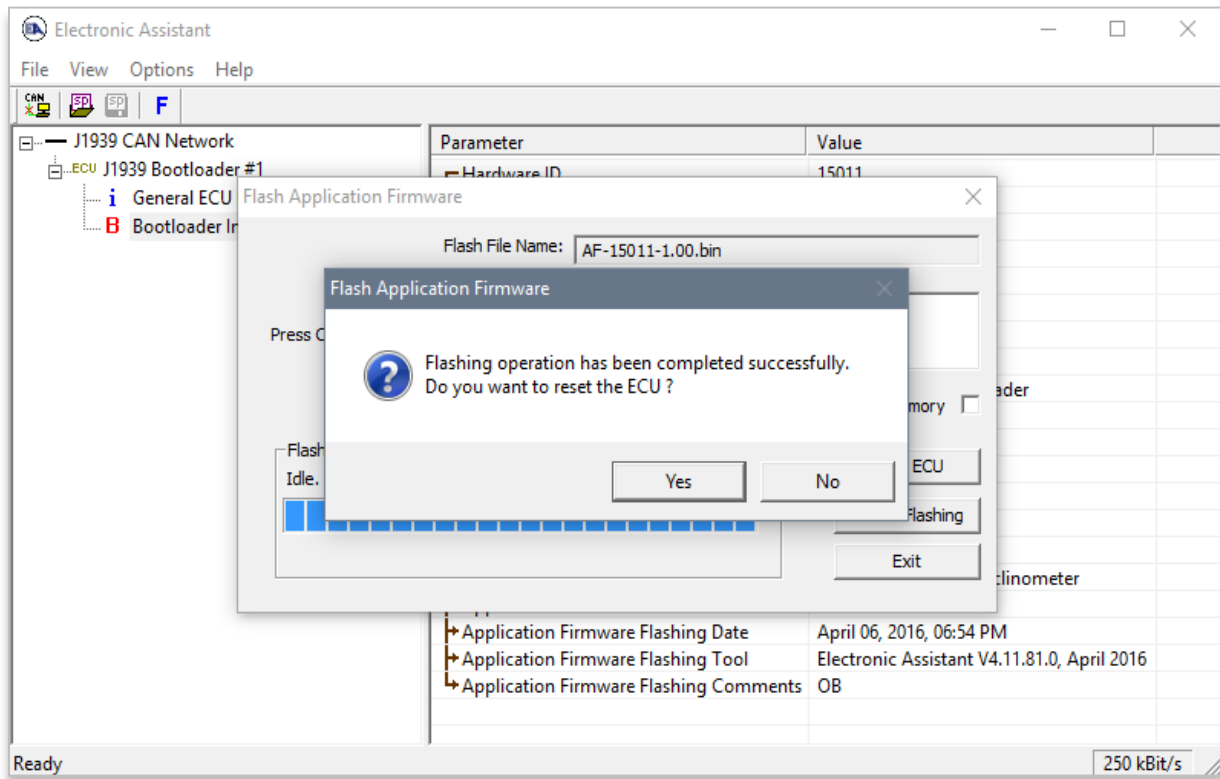

Figure 37. Flashing New Firmware. Final Reset

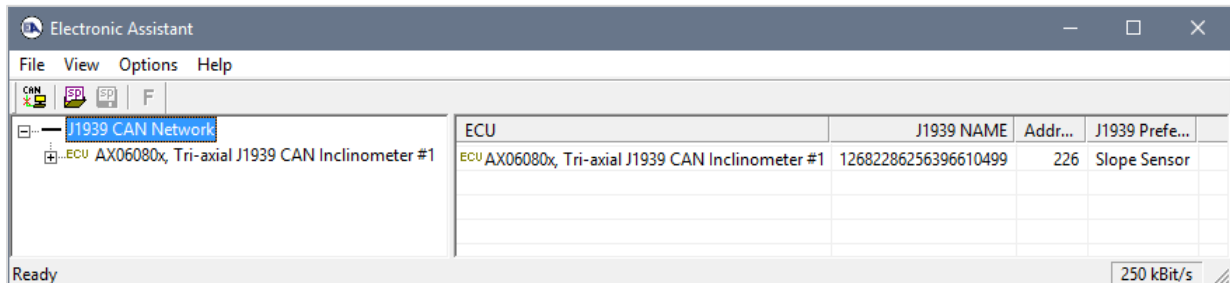

Figure 38. Firmware has been Updated. New Firmware Screen

6 TECHNICAL SPECIFICATIONS

6.1 Performance Parameters

Stated at 25°C unless otherwise specified.

6.1.1 Angular Measurements

Table 18. Angular Measurement Parameters

Parameter	Value	Remarks
Measurement Range	±180° – Pitch & Roll 0...180° – Gravity	±90° default for Pitch & Roll ¹
AX060800, AX060806, AX060807, AX060808		
Resolution	0.35°	Effective Resolution (3.46*NoiseRMS). Maximum, at cut-off frequency Fc=5Hz
Initial Accuracy	±2°	Maximum
Temperature Drift	±3.5°	Maximum, in the full temperature range: -40...85°C
Nonlinearity	±0.7%	Maximum
Cross-Axis Sensitivity	±3.5%	Maximum
Cut-off frequency, Fc	1...50 Hz, 5 Hz default	User-selectable
AX060830, AX060838, AX060810, AX060811, AX061000		
Resolution	0.06°	Effective Resolution (3.46*NoiseRMS). Maximum, at cut-off frequency Fc=5Hz, accelerometer range 1.5g
Initial Accuracy	±2°	Maximum
Temperature Drift	±3°	Maximum, in the full temperature range: -40...85°C
Nonlinearity	±0.1%	Maximum
Cross-Axis Sensitivity	±1%	Maximum
Cut-off frequency, Fc	1...50 Hz, 5 Hz default	User-selectable

¹ ±90° Pitch & ±180° Roll defaults for AX060808, AX060838.

6.2 Power Supply Input

Table 19. Power Supply

Parameter	Value	Remarks
Supply Voltage	9...36 VDC	12V, 24V – nominal
Protection	Reverse polarity, Transients	
AX060800, AX060806, AX060807, AX060808, AX060830, AX060838, AX060810, AX060811		
Supply Current ¹	15 mA 25 mA	Maximum at 24V Maximum at 12V
AX06100		
Supply Current ¹	50 mA 110 mA 95 mA	Maximum at 24V. All signal outputs are in <i>Voltage Output</i> mode. Maximum at 24V. All signal outputs are in <i>Current Output</i> mode at 24mA output current. Maximum at 12V. All signal outputs are in <i>Voltage Output</i> mode.

Parameter	Value	Remarks
	215 mA	Maximum at 12V. All signal outputs are in <i>Current Output</i> mode at 24mA output current.

¹ CAN bus is connected.

6.3 CAN Output

Table 20. CAN Parameters

Parameter	Value	Remarks		
Number of ports	1 CAN Port	To output data and change the internal configuration of the inclinometer		
Communication standards	SAE J1939	Full support for a J1939 ECU is provided. By default, the inclinometer transmits angular information on the CAN network in PGN 61481, <i>Slope Sensor Information 2</i> . User-configurable PGNs are also available.		
	Baud Rate	250 kbit/s, 500 kbit/s, 667kbit/s, 1 Mbit/s. Automatic Baud Rate Detection ¹		
	ISO 11898	120Ohm terminated twisted pair, baud rate up to 1Mbit/s	120Ohm Internal Terminating Resistor	
			AX060800, AX060806, AX060808, AX060830, AX061000, AX060838, AX060810.	No
			AX060807, AX060811.	Yes
Bosch CAN protocol specification 2.0, Part A, B	For the internal CAN controller			
Protection	Short circuit to ground			
	Connection to the power supply	Only for 12V systems, 24V max		

¹ Inclinometers with firmware V1.xx...6.xx could operate only at 250kbit/s baud rate, and with firmware V7.xx...8.xx – at 250, 500, and 1000 kbit/s (1Mbit/s) baud rates.

6.4 Analog Outputs

Table 21. Analog Signal Outputs

Parameter	Value	Remarks
AX061000		
Number of Outputs	3	
Output Modes	Voltage or Current	EA configurable
Protection	Short circuit to ground Transients	Any voltage above 12V can cause a permanent device damage if applied continuously.
Voltage Modes		
Voltage Ranges	0...5 V, 0...10 V, ±5 V, ±10 V	EA configurable
Output Current	≤ 10 mA	Per channel
Output Impedance	0.5 Ohm	Typical
Resolution ¹	0.024%	12-bit
Accuracy ¹	±0.07%	Maximum, in the full temperature range:

Parameter	Value	Remarks
		-40...85°C. 10 kOhm load resistance, separate AGND
Current Modes		
Current Ranges	4...20 mA, 0...20 mA, 0...24 mA	EA configurable
Load Resistance	≤ 400 Ohm	
Output Impedance	50 MOhm	Typical
Resolution ¹	0.024%	12-bit
Accuracy ¹	±0.25%	Maximum, in the full temperature range: -40...85 °C. 300 Ohm load resistance

¹ Parameters are for the signal outputs, not for the inclinometer sensor.

Table 22. Analog Signal Output Default Settings¹

Signal Output	Default Assignment	Remarks
AX061000		
AOUT1	Pitch Angle	Voltage Output. 0...5 V Range. -90° → 0 V, 90° → 5 V
AOUT2	Roll Angle	Voltage Output. 0...5 V Range. -90° → 0 V, 90° → 5 V
AOUT3	Gravity Angle	Voltage Output. 0...5 V Range. 0° → 0 V, 180° → 5 V

¹ In firmware versions 4.xx,...,7.xx, Voltage Range is set to -10...10V, Pitch Angle -90° → -10V, 90° → 10V, Roll Angle -90° → -10V, 90° → 10V, Gravity Angle 0° → -10V, 180° → 10V.

6.5 General Specifications

Table 23. General Specifications

Parameter	Value	Remarks
Sensor Type	MEMS	
Internal Logic	User Configurable	Axiomatic Electronic Assistant [®] , P/N: AX070502
Operating Temperature	-40...+85 °C	Industrial temperature range
Environmental Protection	IP67	IEC 60529 with mated connectors
Vibration	Sinusoidal. 10G Peak, 10Hz-2000Hz-10Hz, 20 Minutes, 8hrs/axis	MIL-STD-202G, method 204D, test condition C
	Random. 7.68 Grms, 10Hz to 2000Hz, 8hrs/axis	Custom, meets or exceeds: MIL-STD-202G, method 214A, test condition I/B
Shock	Half-Sine. 50G Peak, 9ms, 8pulses/axis	Custom, based on: MIL-STD-202G, method 213B, test condition A
AX060800, AX060808, AX060830, AX060838, AX061000		
Size	4.41 x 2.25 x 1.32 in (112 x 57 x 34 mm)	See dimensional drawing
Weight	0.75 lb (0.34 kg)	
AX060806, AX060807, AX060810, AX060811		
Size	3.34 x 3.15 x 2.19 in (85 x 80 x 56 mm)	See dimensional drawing
Weight	1.20 lb (0.54 kg)	

Table 24. EMC Compliances

Standard Name	Description
AX060800, AX060808, AX060830, AX060838	
EN 13309:2010	Construction Machinery. Electromagnetic Compatibility of Machines with Internal Electrical Power Supply

6.6 Inclinometer Modifications

Table 25. Inclinometer Modifications

P/N	Enclosure	Connectors	Internal CAN Terminating Resistor	Sensor
AX060800	AX060800	Two M12 Connectors	No	Regular
AX060808 ¹				
AX060806	AX060806	4-pin Deutsch DT13-4P connector	Yes	High-performance
AX060807				
AX060830	AX060800	Two M12 Connectors	No	High-performance
AX061000				
AX060838 ¹				
AX060810	AX060806	4-pin Deutsch DT13-4P connector	Yes	High-performance
AX060811				

¹ Legacy product with vertical original unit frame orientation. Starting from firmware V5.0, the unit frame orientation is configurable.

6.7 Enclosures

6.7.1 AX060800

The AX060800 inclinometer has a cast aluminum enclosure with two 5-pin M12 A-coded round connectors, see Figure 39.

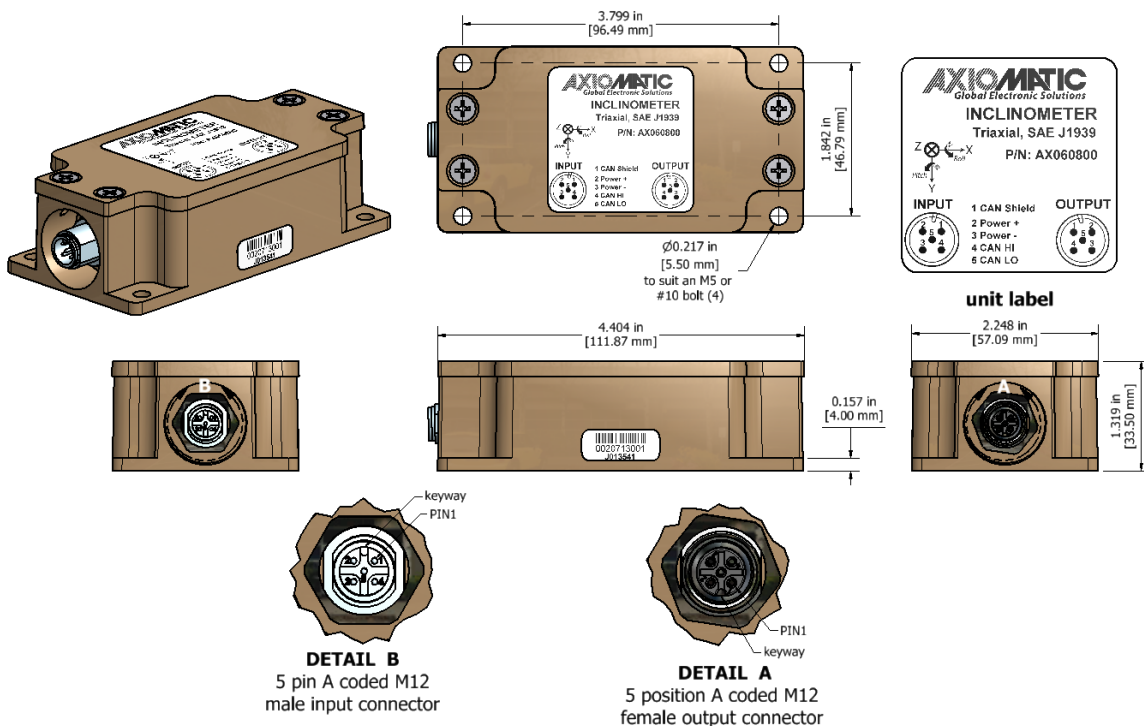

Figure 39. AX060800 Dimensional Drawing

Inclinometers with the same enclosure, see Table 25, have a different part number on the label and can have a different pinout and a unit orientation.

Use mating connectors compliant with IEC 61076-2-101:2012.

If only one connector is used, an M12 sealing cap with IP67 rating should be installed on the unused connector. PROT-M12 FB – 1555538 from PHOENIX CONTACT is recommended for the unused output M12 connector, Axiomatic P/N AX070140.

6.7.1.1 Connector Pinout

Inclinometers in AX060800 enclosure have two versions of the pinout.

6.7.1.1.1 CAN Only

The CAN only pinout is used in inclinometers: AX060800, AX060808, AX060830, AX060838 that do not have any other interfaces but CAN, see Figure 40.

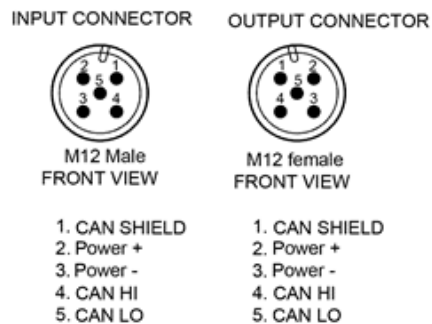

Figure 40. AX060800 Connector Pinout

There is only one CAN port supported by the units. Both CAN connectors are physically connected together to facilitate cable routing in the user's system.

A mating plug with CAN termination, P/N: AX070114, can be ordered for applications requiring termination of the CAN network on the unit.

6.7.1.1.2 CAN and Analog Signal Outputs

Inclinometer AX061000 in addition to CAN interface has 3 analog signal outputs, see Figure 41.

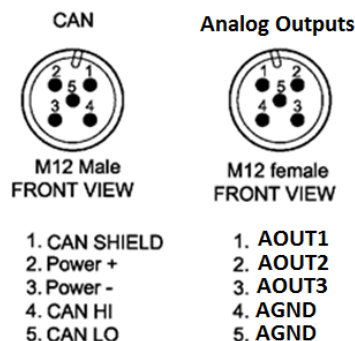

Figure 41. AX061000 Connector Pinout

The inclinometer Analog Outputs connector has two identical analog ground pins *AGND*. They are used as a return path for *AOUT1...AOUT3*. The pins are internally connected together and with the *Power*- pin on the CAN connector through a low resistance protection circuit, see Figure 9.

It is recommended to use separate *AGND* pins for current and voltage outputs to improve the accuracy of the voltage outputs.

Be careful not to use the CAN only output connector mating cable with AX061000 units – the power on pins 2 and 3 can damage the analog outputs.

6.7.1.2 Unit Orientation

The original default unit frame orientation, together with the *Pitch* and *Roll* angular directions, is shown on the inclinometer label, see Figure 42. This orientation is suitable for a horizontal installation.

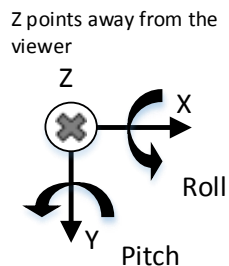

Figure 42. Horizontal Unit Frame Orientation

The legacy vertical mount inclinometers AX060808 and AX060838 were designed for a vertical installation when the inclinometer unit frame orientation was not configurable (before firmware V5.00 was released). Their default unit frame orientation is presented in Figure 43.

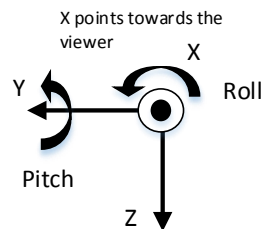

Figure 43. Vertical Unit Frame Orientation

Starting from firmware V5.00, the original unit frame orientation can be changed using the initial unit frame rotation configuration parameters in the [Unit Installation](#) function block.

It is necessary to remember that the unit frame Z-axis should be coincident with the gravity acceleration vector when the unit is installed at the customer site.

6.7.2 AX060806

The AX060806 inclinometer has a cast aluminum enclosure with one 4-pin Deutsch DT13-4P connector, see Figure 44.

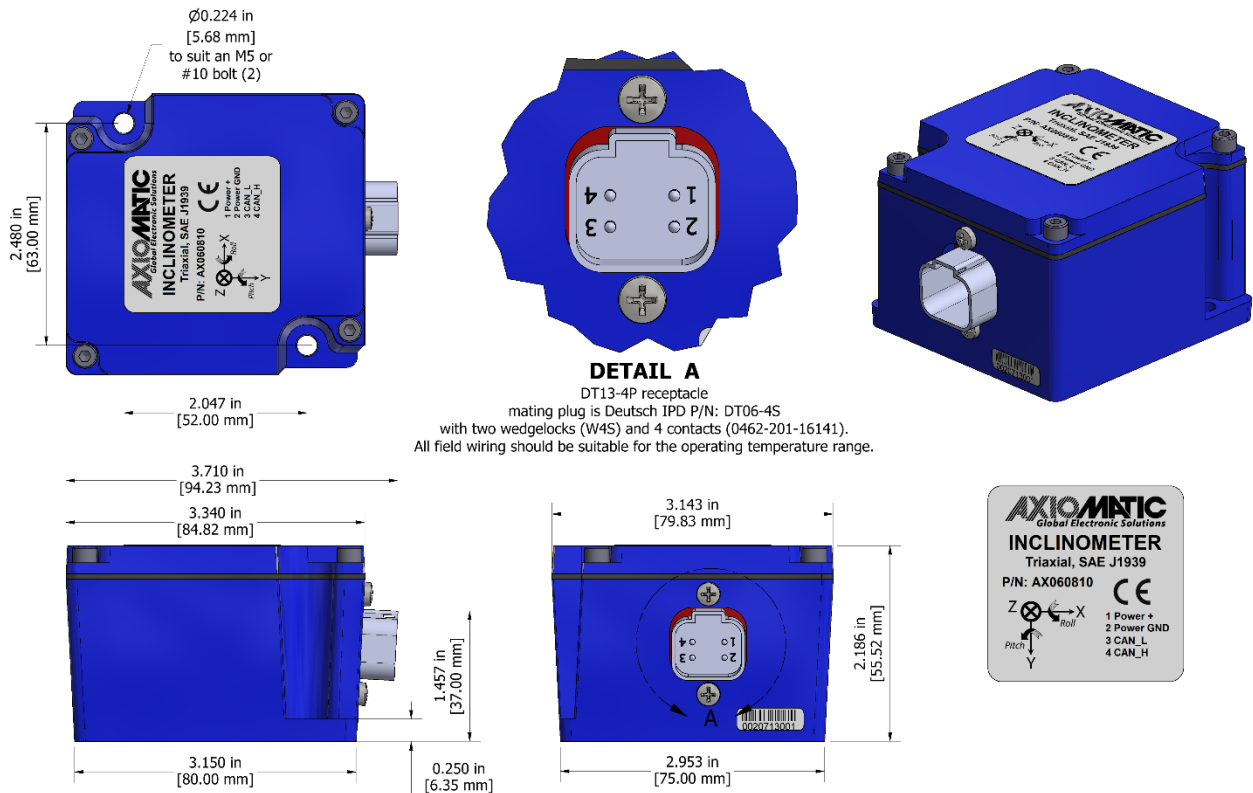

Figure 44. AX060806 Dimensional Drawing

Use mating Deutsch connector DT06-4S.

Inclinometers with the same enclosure, see Table 25, have a different part number on the label but retain the same pinout and unit orientation.

6.7.2.1 Connector Pinout

Inclinometers: AX060806, AX060807, AX060810, AX060811 have the following connector pinout, see Figure 45.



1. Power +
2. Power -
3. CAN LO
4. CAN HI

Figure 45. AX060806 Connector Pinout

6.7.2.2 Unit Orientation

All inclinometers in AX060806 enclosure use the same default unit frame orientation suitable for horizontal installation, see Figure 42.

The default unit frame orientation can be changed using configuration parameters starting from firmware V5.00.

6.8 *Installation*

See mechanical installation information on the dimensional drawings.

The CAN wiring is considered intrinsically safe. All field wiring should be suitable for the operating temperature range of the unit. CAN wiring may be shielded using a shielded twisted conductor pair and the shield must be connected to the CAN_SHIELD pin if provided on the connector.

7 VERSION HISTORY

User Manual Version	Firmware version	Electronic Assistant® (EA) version	Date	Author	Modifications
9C	9.xx	5.15.108.0 or higher	Feb. 4, 2022	Olek Bogush	<ul style="list-style-type: none"> Connector P/N DT15-4P was corrected to DT13-4P.
9B	9.xx	5.15.108.0 or higher	Sep 14, 2020	Olek Bogush	<ul style="list-style-type: none"> Added notes excluding Proprietary A PGN (61184) from customer's use in function blocks. Updated <i>J1939 Standard Support</i> table, <i>CAN Input Signal</i> and <i>CAN Output Message</i> function blocks.
9A	9.xx	5.15.108.0 or higher	Feb 27, 2020	Olek Bogush	<ul style="list-style-type: none"> Added <i>EMC Compliances</i> table in <i>General Specifications</i>. Updated Acronyms section.
9	9.xx	5.15.108.0 or higher	Dec 20, 2019	Olek Bogush	<ul style="list-style-type: none"> Added 667kbit/s baud rate. Updated relevant sections of the UM.
8A	8.xx	5.14.108.0 or higher	Nov 19, 2019	Olek Bogush	<ul style="list-style-type: none"> Corrected list of inclinometers with a high-performance sensor in <i>Accelerometer</i> function block and in <i>Accelerometer Sensor Range</i> comments.
	7.xx	5.14.105.0 or higher			
8	8.xx	5.14.108.0 or higher	Nov 12, 2019	Olek Bogush	<ul style="list-style-type: none"> Updated <i>Analog Signal Output Default Settings</i> for AX061000 in <i>Technical Specifications</i>. Updated <i>Analog Outputs</i> in <i>Default Settings</i>. Updated <i>Analog Signal Output Function Block Configuration Parameters</i> in <i>Analog Signal Outputs</i>. Updated the user manual version description in <i>Introduction</i>. Updated <i>Electronic Assistant Software</i> sub-section.
	7.xx	5.14.105.0 or higher			
7B	7.xx	5.14.105.0 or higher	October 22, 2019	Olek Bogush	<ul style="list-style-type: none"> Updated <i>Supply Current</i> for AX060800, AX060806, AX060807, AX060808, AX060830, AX060838, AX060810, AX060811 in <i>Technical Specifications</i>.
7A	7.xx	5.14.105.0 or higher	Sept 10, 2019	Olek Bogush	<ul style="list-style-type: none"> Returned back legacy vertical mount inclinometer modifications: AX060808, AX060838.
7	7.xx	5.14.105.0 or higher	July 18, 2019	Olek Bogush	<ul style="list-style-type: none"> Added automatic baud rate detection from the list of 250kbit/s, 500kbit/s, 1Mbit/s baud rates. Updated relevant sections of the UM. Updated <i>J1939 Network</i> sub-section. Added <i>Baud Rate and Automatic Baud Rate Detection</i> configuration parameters. Updated <i>Slew Rate</i> configuration parameter description.

User Manual Version	Firmware version	Electronic Assistant® (EA) version	Date	Author	Modifications
6A	6.xx	5.13.103.0 or higher	June 18, 2019	Olek Bogush	<ul style="list-style-type: none"> Updated <i>J1939 Network</i> sub-section.
6	6.xx	5.13.103.0 or higher	May 31, 2019	Olek Bogush	<ul style="list-style-type: none"> Added <i>Accelerometer Sensor Range</i> configuration parameter in <i>Accelerometer</i> function block. Updated <i>Angular Measurement, Resolution</i> remarks for high-performance inclinometers in <i>Technical Specifications</i>. Removed vertical mount inclinometer modifications: AX060808, AX060838. Updated <i>Unit Orientation</i> sub-sections.
5	5.xx	5.13.100.0 or higher	Dec 20, 2018	Olek Bogush	<ul style="list-style-type: none"> Added configurable unit frame orientation. Added <i>Coordinate Rotation Yaw, Pitch and Roll Angles</i> in <i>Unit Installation</i> function block. Made obsolete vertical mount inclinometer modifications. Updated <i>Gimbal Lock, Practical Recommendations, Unit Installation, Inclinometer Modifications, Unit Orientation</i> sub-sections. Added <i>Analog Signal Output Default Settings</i> for AX061000 in <i>Analog Outputs</i> sub-section. Updated <i>CAN Parameters, CAN and Analog Signal Outputs</i>.
4C	4.xx	5.13.98.0 or higher	Nov 16, 2018	Olek Bogush	<ul style="list-style-type: none"> Clarified <i>Gimbal Lock</i> in <i>Angle Measurements</i>.
4B	4.xx	5.13.98.0 or higher	October 31, 2018	Olek Bogush	<ul style="list-style-type: none"> Corrected <i>Figure 7. Single-Axis Measurements</i>. Changed the user manual name from UMAX06xxxx to UMAX0608XX-1000.
4A	4.xx	5.13.98.0 or higher	October 19, 2018	Olek Bogush	<ul style="list-style-type: none"> Corrected default measurement ranges in <i>Table 18. Angular Measurement Parameters</i>. Corrected <i>Supply Current</i> for AX06100 in <i>Table 19. Power Supply</i>. Corrected <i>Default Settings</i> in <i>Angle Measurements</i>.
4	4.xx	5.13.98.0 or higher	October 5, 2018	Olek Bogush	<ul style="list-style-type: none"> Added AX06100, Tri-Axial Inclinometer with Analog Outputs. Updated <i>Inclinometer Description, Hardware Block Diagram, J1939 Name and Address, Inclinometer Logical Structure, Configuration Example, Technical Specifications</i>. Added <i>Weight</i> value for AX060806, AX060807, AX060810, AX060811.

User Manual Version	Firmware version	Electronic Assistant® (EA) version	Date	Author	Modifications
					<ul style="list-style-type: none"> Changed the user manual name from UMAX06080x to UMAX06xxxx.
3F	3.xx	5.13.90.0 or higher	August 13, 2018	Olek Bogush	<ul style="list-style-type: none"> Corrected default PGN in <i>Technical Specifications, CAN Output</i>. Combined <i>Static Parameters</i> and <i>Dynamic Parameters</i> into <i>Angular Measurements</i> in <i>Technical Specifications</i>. Removed <i>Setting Time</i>.
3E	3.xx	5.13.90.0 or higher	June 25, 2018	Olek Bogush	<ul style="list-style-type: none"> Added default <i>Pitch</i> and <i>Roll</i> to the <i>Measurement Range</i> parameter in the <i>Technical Specifications</i> section. Updated <i>Default Settings</i> sub-section. Corrected <i>Configuration Example</i>. Updated Finnish office phone number on the front page.
3D	3.xx	5.13.90.0 or higher	March 12, 2018	Olek Bogush	<ul style="list-style-type: none"> Corrected <i>Euler Angles</i> subsection.
3C	3.xx	5.13.90.0 or higher	January 9, 2018	Olek Bogush	<ul style="list-style-type: none"> Corrected <i>Binary Function</i> default configuration parameters. Corrected <i>Configuration Example</i>. Corrected EA version numbering in <i>Version History</i>.
3B	3.xx	5.13.90.0 or higher	August 4, 2017	Olek Bogush	<ul style="list-style-type: none"> In <i>Static Parameters</i> sub-section changed <i>Resolution</i> remarks for clarity. Added P/N AX070140 for M12 sealing cap.
3A	3.xx	5.13.90.0 or higher	June 22, 2017	Olek Bogush	<ul style="list-style-type: none"> Added a recommended sealing cap for the unused output M12 connector.
3	3.xx	5.13.90.0 or higher	May 26, 2017	Olek Bogush	<ul style="list-style-type: none"> Added high-performance modifications: AX060830, AX060838, AX060810, AX060811. Rewrote <i>Technical Specifications</i> section. Removed a single M12 connector modification AX060804.
2	2.xx	5.13.90.0 or higher	May 11, 2017	Olek Bogush	<ul style="list-style-type: none"> Added <i>Unit Rotation Angle</i>, <i>Tilt Angle Range</i>, <i>Gravity Acceleration Error</i> and <i>Maximum Gravity Acceleration Error</i> in the <i>Angle Measurement</i> Function Block. Changed the default <i>Tilt Angle Range</i> from ± 180 to ± 90 degrees for a smooth angular transition in roll-over points. Changed default PGN from <i>SSI</i> to <i>SSI2</i>. Updated <i>Angle Measurements</i> section. Added <i>Maximum Gravity Acceleration Error</i> subsection. Added <i>Practical Recommendations</i> for choosing an angle type for the angle

User Manual Version	Firmware version	Electronic Assistant® (EA) version	Date	Author	Modifications
					<p>measurement, based on the user application requirements.</p> <ul style="list-style-type: none"> • Updated <i>Flashing New Firmware</i>.
1F	1.xx	4.11.81.0 or higher	April 25, 2017	Olek Bogush	<ul style="list-style-type: none"> • Updated <i>Initial Accuracy</i> in <i>Technical Specifications</i>.
1E	1.xx	4.11.81.0 or higher	April 17, 2017	Olek Bogush	<ul style="list-style-type: none"> • Added vertical mounting version AX060808. • Updated: <i>Technical Specifications</i> section; <i>Angle Measurements</i>, <i>CAN Interface</i>, <i>CAN Output Message</i> subsection. • Added <i>Data Range</i> to the standard PGN descriptions.
1D	1.xx	4.11.81.0 or higher	March 29, 2017	Olek Bogush	<ul style="list-style-type: none"> • Added DP15-4P versions. • Updated <i>Hardware Block Diagram</i>, <i>Network Bus Terminating Resistors</i>, and <i>Technical Specifications</i> sections.
1C	1.xx	4.11.81.0 or higher	January 17, 2017	Olek Bogush	<ul style="list-style-type: none"> • Corrected the <i>Gimbal Lock</i> section.
1B	1.xx	4.11.81.0 or higher	November 3, 2016	Olek Bogush	<ul style="list-style-type: none"> • Added unit vibration and shock data and updated the dimensional drawing for AX060800.
1A	1.xx	4.11.81.0 or higher	October 17, 2016	Olek Bogush	<ul style="list-style-type: none"> • Added unit weight and dimensional drawing for AX060800. • Corrected <i>Figure 46. The Inclinometer Logical Block Diagram</i>. • Removed pending <i>Compliances</i> and <i>Certifications</i> sections.
1	1.xx	4.11.81.0 or higher	April 15, 2016	Olek Bogush	<ul style="list-style-type: none"> • Initial release.

OUR PRODUCTS

AC/DC Power Supplies
Actuator Controls/Interfaces
Automotive Ethernet Converters
Battery Chargers
CAN Controls, Routers, Repeaters
CAN/WiFi, CAN/Bluetooth, Routers
Current/Voltage Converters
DC/DC Power Converters
Engine Temperature Scanners
Ethernet/CAN Converters,
Gateways, Switches
Fan Drive Controllers
Gateways, CAN/Modbus Protocols
Gyroscope Inclinometers
Hydraulic Valve Controllers
Inclinometers, Triaxial
I/O Controls
LVDT Signal Converters
Machine Controls
Modbus Controls
Motor Controls
Power Supplies, DC/DC, AC/DC
PWM Signal Converters/Isolators
Resolver Signal Conditioners
Service Tools
Signal Conditioners, Converters
Strain Gauge CAN Controls
Surge Suppressors

OUR COMPANY

Axiomatic provides electronic machine control components to the off-highway, commercial vehicle, electric vehicle, power generator set, material handling, renewable energy and industrial OEM markets. ***We innovate with engineered and off-the-shelf machine controls that add value for our customers.***

QUALITY DESIGN AND MANUFACTURING

We have an ISO9001:2015 registered design/manufacturing facility in Canada.

WARRANTY, APPLICATION APPROVALS/LIMITATIONS

Axiomatic Technologies Corporation reserves the right to make corrections, modifications, enhancements, improvements, and other changes to its products and services at any time and to discontinue any product or service without notice. Customers should obtain the latest relevant information before placing orders and should verify that such information is current and complete. Users should satisfy themselves that the product is suitable for use in the intended application. All our products carry a limited warranty against defects in material and workmanship. Please refer to our Warranty, Application Approvals/Limitations and Return Materials Process at <https://www.axiomatic.com/service/>.

COMPLIANCE

Product compliance details can be found in the product literature and/or on axiomatic.com. Any inquiries should be sent to sales@axiomatic.com.

SAFE USE

All products should be serviced by Axiomatic. Do not open the product and perform the service yourself.



This product can expose you to chemicals which are known in the State of California, USA to cause cancer and reproductive harm. For more information go to www.P65Warnings.ca.gov.

SERVICE

All products to be returned to Axiomatic require a Return Materials Authorization Number (RMA#) from sales@axiomatic.com. Please provide the following information when requesting an RMA number:

- Serial number, part number
- Hours of operation, description of problem
- Wiring set up diagram, application and other comments as needed

DISPOSAL

Axiomatic products are electronic waste. Please follow your local environmental waste and recycling laws, regulations and policies for safe disposal or recycling of electronic waste.

CONTACTS

Axiomatic Technologies Corporation
5915 Wallace Street
Mississauga, ON
CANADA L4Z 1Z8
TEL: +1 905 602 9270
FAX: +1 905 602 9279
www.axiomatic.com
sales@axiomatic.com

Axiomatic Technologies Oy
Höytämöntie 6
33880 Lempäälä
FINLAND
TEL: +358 103 375 750
FAX: +358 3 3595 660
www.axiomatic.com
salesfinland@axiomatic.com