



USER MANUAL UMAX0609x1

TRI-AXIAL GYRO INCLINOMETER

With CANopen[®]

USER MANUAL

P/N: AX060901 – Two M12 Connectors

P/N: AX060911 – Two M12 Connectors, Extended Dynamic Range

In Europe:
Axiomatic Technologies Oy
Höytämöntie 6
33880 LEMPÄÄLÄ - Finland
Tel. +358 103 375 750
Fax. +358 3 3595 660
www.axiomatic.fi

In North America:
Axiomatic Technologies Corporation
5915 Wallace Street
Mississauga, ON Canada L4Z 1Z8
Tel. 1 905 602 9270
Fax. 1 905 602 9279
www.axiomatic.com

VERSION HISTORY

| User Manual Version | Firmware version | Date | Author | Modifications |
|---------------------|------------------|-------------|-----------------|--|
| 1.2 | 1.xx | April, 2020 | Peter Sotirakos | <ul style="list-style-type: none">• Updated the Vibration, Shock and Weight Sections in General Specifications |
| 1.1 | 1.xx | Sept., 2019 | Peter Sotirakos | <ul style="list-style-type: none">• Corrected default communication values in the Object Dictionary |
| 1 | 1.xx | June, 2019 | Peter Sotirakos | <ul style="list-style-type: none">• Modified version of UMAX0609XX• Updated to include CANopen communication sections instead of SAE J1939 sections |

ACRONYMS

| | |
|----------|---|
| 3D | Three-Dimensional |
| CAN | Controller Area Network |
| CANopen® | CANopen® is a registered community trademark of CAN in Automation e.V. |
| CE | The CE mark, or formerly EC mark, is a mandatory conformity marking for certain products sold within the European Economic Area (EEA) since 1985 |
| COB | Communication Object |
| EA | Electronic Assistant®. PC application software from Axiomatic, primarily designed to view and program Axiomatic control configuration parameters (setpoints) through CAN bus using J1939 Memory Access Protocol |
| ECU | Electronic Control Unit |
| EDS | Electronic Data Sheet |
| EEPROM | Electrically Erasable Programmable Read-Only Memory |
| EKF | Extended Kalman Filter |
| EMC | Electromagnetic Compatibility |
| EMCY | Emergency |
| EMI | Electromagnetic Interference |
| GPS | Global Positioning System |
| LSB | Less Significant Byte (or Bit) |
| LSS | Layer Setting Service |
| MEMS | Microelectromechanical System |
| MSB | Most Significant Byte (or Bit) |
| NED | North-East-Down coordinate system |
| NMT | Network Management |
| PC | Personal Computer |
| P/N | Part Number |
| RoHS | Restriction of Hazardous Substances |
| RO | Read Only Object |
| RPDO | Received Process Data Object |
| RW | Read/Write Object |

| | |
|-----------|---|
| RWP | Read/Write Protected Object |
| SAE J1939 | CAN-based higher-level protocol designed and supported by Society of Automobile Engineers (SAE) |
| SAE J670 | Vehicle Dynamics Terminology standard designed and supported by Society of Automobile Engineers (SAE) |
| SDO | Service Data Object |
| TPDO | Transmitted Process Data Object |
| USB | Universal Serial Bus |
| UTP | Un-shielded twisted pair |
| XOR | Exclusive OR, a logical operation |

TABLE OF CONTENTS

| | | |
|-----------|---|----|
| 1 | INTRODUCTION..... | 7 |
| 2 | INCLINOMETER DESCRIPTION..... | 8 |
| 2.1 | Inclinometer Modifications..... | 8 |
| 2.2 | Theory of Operation..... | 8 |
| 2.2.1 | Unit Coordinate System..... | 8 |
| 2.2.2 | Unit Reference Frames..... | 9 |
| 2.2.3 | Angle measurements..... | 10 |
| 2.2.3.1 | Static Condition..... | 10 |
| 2.2.3.2 | Dynamic Condition..... | 10 |
| 2.2.3.3 | Sensor Fusion..... | 11 |
| 2.2.4 | Tilt and Rotation Angles..... | 11 |
| 2.2.4.1 | Tilt Angles..... | 11 |
| 2.2.4.2 | Rotation Angles..... | 13 |
| 2.2.4.2.1 | Unit Rotation Angles..... | 13 |
| 2.2.4.2.2 | Euler Angles..... | 14 |
| 2.2.4.2.3 | Gimbal Lock..... | 16 |
| 2.2.4.3 | Maximum Gravity Acceleration Error..... | 17 |
| 2.2.4.4 | Practical Recommendations..... | 17 |
| 2.2.4.5 | Default Settings..... | 20 |
| 2.3 | Hardware Block Diagram..... | 20 |
| 2.4 | Software Organization..... | 21 |
| 2.4.1 | Angular Measurements..... | 21 |
| 2.4.2 | Configurable Internal Architecture..... | 22 |
| 3 | INCLINOMETER LOGICAL STRUCTURE..... | 23 |
| 3.1 | Function Block Signals..... | 24 |
| 3.1.1 | Undefined Signal..... | 24 |
| 3.1.2 | Discrete Signal..... | 24 |
| 3.1.3 | Continuous Signal..... | 24 |
| 3.1.4 | Signal Type Conversion..... | 24 |
| 3.1.4.1 | Discrete to Continuous Conversion..... | 24 |
| 3.1.4.2 | Continuous to Discrete Conversion..... | 24 |
| 3.1.4.3 | Undefined Signal Conversion..... | 25 |
| 3.1.5 | Function Block Signal/Control Source List..... | 25 |
| 3.2 | Gyroscope..... | 28 |
| 3.2.1 | Gyroscope Signals..... | 28 |
| 3.2.2 | Gyroscope Configuration Parameters..... | 29 |
| 3.3 | Accelerometer..... | 29 |
| 3.3.1 | Accelerometer Signals..... | 29 |
| 3.3.2 | Accelerometer Configuration Parameters..... | 30 |
| 3.4 | Angle Measurement..... | 31 |
| 3.4.1 | Angle Measurement Signals..... | 31 |
| 3.4.2 | Angle Measurement Configuration Parameters..... | 33 |
| 3.5 | Unit Installation..... | 35 |
| 3.5.1 | Unit Frame Orientation Examples..... | 36 |
| 3.6 | Sensor Calibration..... | 38 |
| 3.7 | Binary Functions..... | 39 |
| 3.8 | Global Parameters..... | 42 |
| 3.9 | RPDO Messages..... | 43 |

| | | |
|---------|---|-------------------------------------|
| 3.10 | Miscellaneous Parameters..... | 43 |
| 4 | CANOPEN® OBJECT DICTIONARY | 45 |
| 4.1 | NODE ID and BAUDRATE..... | 45 |
| 4.2 | COMMUNICATION OBJECTS (DS-301)..... | 45 |
| 4.3 | MANUFACTURER OBJECTS | 50 |
| 5 | FLASHING NEW FIRMWARE | 53 |
| 6 | TECHNICAL SPECIFICATIONS | 56 |
| 6.1 | Performance Parameters..... | 56 |
| 6.1.1 | Angular Measurements..... | 56 |
| 6.1.1.1 | AX060900, AX062008..... | 56 |
| 6.1.1.2 | AX060910, AX062018..... | 56 |
| 6.1.2 | Angular Rate Measurements | 57 |
| 6.1.2.1 | AX060900, AX062008..... | 57 |
| 6.1.2.2 | AX060910, AX062018..... | 57 |
| 6.2 | Power Supply Input..... | 57 |
| 6.3 | CAN Output..... | 58 |
| 6.4 | General Specifications | 58 |
| 6.5 | Enclosure | 58 |
| 6.6 | Unit Orientation | 60 |
| 6.6.1 | Horizontal Unit Orientation..... | 60 |
| 6.6.2 | Vertical Unit Orientation | Error! Bookmark not defined. |
| 6.7 | Installation..... | 60 |
| 7 | THIRD PARTY SOFTWARE LICENSE NOTICES..... | 61 |

1 INTRODUCTION

The following user manual describes: architecture, functionality, configuration parameters and object details for the Tri-Axial Gyro Inclinometer. It also contains technical specifications and installation instructions for the device.

The various function blocks supported by the Inclinometer are outlined in the following sections. All objects are user configurable using standard commercially available tools that can interact with a CANopen® Object Dictionary via an EDS file.

2 INCLINOMETER DESCRIPTION

The inclinometer is designed to measure pitch and roll inclination angles¹ in the presence of dynamic disturbances: linear accelerations, vibrations, etc., in a full ± 180 -degree orientation range. The unit can also output: gravity angle, accelerations and angular rates in three orthogonal directions.

¹Single-axis gyroscope modifications are designed to measure only roll inclination angle.

The inclinometer transmits data over CAN bus using a standard CANopen protocol. The unit original configuration can be changed using any third party CANopen tools.

The inclinometer can be configured through a set of configuration parameters to fit the user-specific application requirements.

2.1 Inclinometer Modifications

The inclinometers come in several modifications: with gyroscopes on all three axes or only on one axis; capable to operate in regular or extended range of disturbances.

Inclinometer modifications with gyroscopes on all three axes can dynamically compensate all measurement angles.

A less expensive modification with a single-axis gyroscope can compensate only one angle in the direction of the gyroscope measurements. It is normally used for single-angle measurements but without gyroscope compensation can measure all inclination angles.

The extended dynamic range inclinometers have a larger measurement range accelerometer and gyroscopes, which allow them to operate without saturation in a wider range of dynamic disturbances. A separate precision accelerometer provides accurate static measurements of all inclination angles.

2.2 Theory of Operation

2.2.1 Unit Coordinate System

The inclinometer uses a standard right-handed Z-down Cartesian coordinate system, see Figure 1.

The arrows in Figure 1 represent a direction of motion that produces a positive change of the parameter. For a_x , a_y , a_z accelerations, the positive acceleration direction is the same as the axis direction. For θ , ϕ , ψ rotation angles the positive direction is counterclockwise about the axis of rotation (right-hand rule).

The Z-down coordinate system is described by in the SAE J670 standard for automotive applications. This system is similar to the NED (North-East-Down) coordinate system used in aerospace and navigation, but without reference to the cardinal directions.

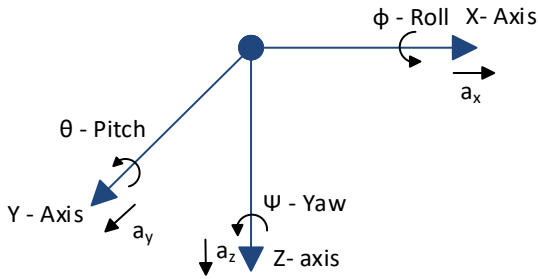

Figure 1. Inclinometer Coordinate System

2.2.2 Unit Reference Frames

Several Z-down coordinate systems or frames are used to describe the inclinometer orientation.

The (X,Y,Z) coordinate system attached to the unit forms a unit or inclinometer frame, see Figure 2. The original (default) unit frame orientation is shown on the inclinometer label. It can be changed using configuration parameters to facilitate the unit installation.

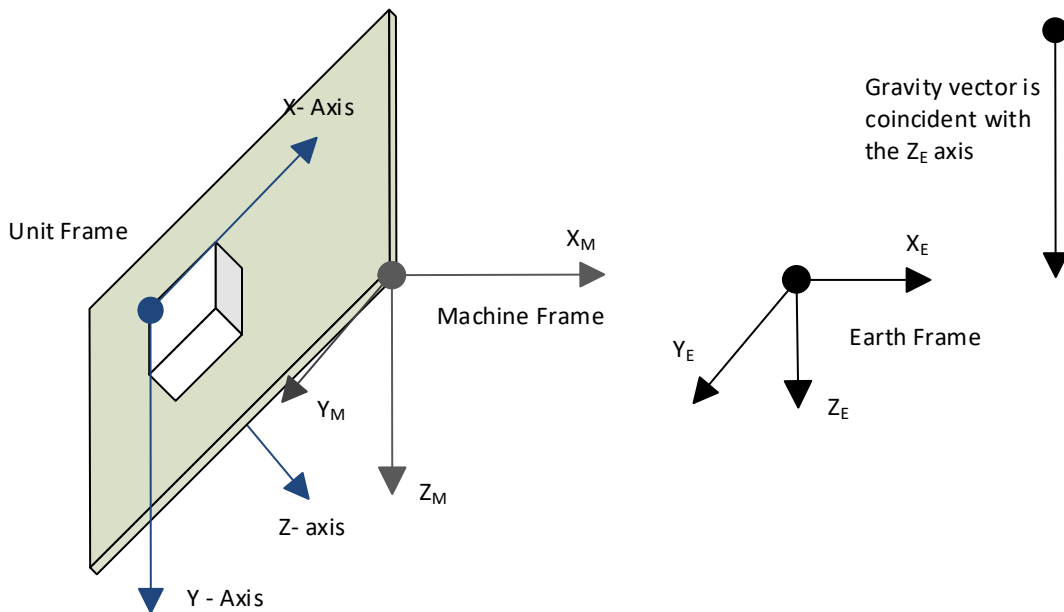

Figure 2. Inclinometer Reference Frames

The (X_M, Y_M, Z_M) coordinate system attached to the machine, where the inclinometer is installed, defines a machine frame. The Earth coordinate system (X_E, Y_E, Z_E) , aligned with the Earth gravity, defines the Earth absolute reference frame.

The machine frame is coincident with the Earth reference frame in the initial null-angle position of the machine when it is leveled on the operation area.

The unit calculates accelerations, angles and angular rates referred to the machine frame (X_M, Y_M, Z_M) . Conversion from the unit frame (X, Y, Z) to the machine frame (X_M, Y_M, Z_M) is performed internally using the unit initial installation angles. They are set to zero by default.

After the inclinometer is installed on the machine at the customer site, the customer can set-up the unit initial installation angles through configuration parameters.

To simplify further description of inclinometer operations, unless specially mentioned, it will be assumed that the unit frame orientation is original, initial installation angles are zero and all inclinometer parameters are referred therefore to the unit frame (X,Y,Z).

2.2.3 Angle measurements

2.2.3.1 Static Condition

In the static condition, the inclination angles are measured by a three-axis MEMS accelerometer. The accelerometer senses accelerations in three orthogonal directions X, Y and Z: $\vec{a} = (a_x, a_y, a_z)$.

This acceleration vector is a superposition of external accelerations applied to the unit and the gravity acceleration:

$$\vec{a} = \vec{A} - \vec{g}, \quad (1)$$

where: $\vec{A} = (A_x, A_y, A_z)$ – external accelerations applied to the unit,
 $\vec{g} = (g_x, g_y, g_z)$ – gravity acceleration.

Since the external accelerations are absent in the static condition ($\vec{A} = 0$), the gravity acceleration vector is:

$$\vec{g} = -\vec{a}. \quad (2)$$

The inclinometer angular displacement can be presented as a rotation of the unit coordinate system (frame) from the original position, with the predefined value of the gravity vector, to the current position with the measured value of the same gravity vector. For example, if the original position is defined in the absolute Earth frame, then $\vec{g}_E = (0, 0, 1)$ and the gravity vector in the unit frame $\vec{g} = \vec{g}_U$ is:

$$\vec{g}_U^T = R_E^U \vec{g}_E^T, \quad (3)$$

where R_E^U – rotation matrix converting \vec{g}_E into \vec{g}_U (symbol T states that the vectors are transposed for this operation).

The θ – pitch, ϕ – roll, and ρ – gravity angles can be calculated from the rotation matrix elements, which themselves can be calculated from \vec{g}_U . There is not enough information based only on the gravity vector to calculate the ψ – yaw angle.

2.2.3.2 Dynamic Condition

In dynamics, the inclination angles are measured using three single-axis MEMS gyroscopes. The gyroscopes provide angular rates about three orthogonal directions X, Y and Z: $\vec{\omega} = (\omega_x, \omega_y, \omega_z)$.¹

¹Single-axis gyro modifications contain only one gyroscope that provides angular rate only in X direction.

When the inclinometer rotation is described by a quaternion $\mathbf{q} = \mathbf{q}(t)$, the rotation dynamics is defined by the following differential equation:

$$\dot{\mathbf{q}} = \frac{1}{2} \Omega \cdot \mathbf{q} \quad (4)$$

where: $\Omega = \begin{bmatrix} 0 & -\omega_x & -\omega_y & -\omega_z \\ \omega_x & 0 & \omega_z & -\omega_y \\ \omega_y & -\omega_z & 0 & \omega_x \\ \omega_z & \omega_y & -\omega_x & 0 \end{bmatrix}$ – rotation matrix for quaternion, derived from angular rates.

The inclinometer angular displacement can be found by integrating this equation over time and converting the result to the corresponding rotation matrix and the estimate of the gravity vector in the unit frame $\vec{\hat{g}}_U$. This estimate can be used for calculating: $\hat{\theta}$ – pitch, $\hat{\phi}$ – roll, and $\hat{\rho}$ – gravity angles the same way as for the inclinometer static condition.

2.2.3.3 Sensor Fusion

Both static and dynamic angular measurements have their own advantages and disadvantages. The static measurements based on the accelerometer data are susceptible to parasitic accelerations normally present in a moving machine.

The dynamic measurements, on the other hand, accumulate integration errors of the gyroscope angular rates and are very sensitive to short-term sensor saturations that void any further measurements. This does not allow using dynamic measurements alone. They need to be constantly corrected by the static measurement data.

To combine the advantages of both methods, the inclinometer angular displacements, calculated using accelerometer and gyroscope data, are fused together using the Extended Kalman Filter (EKF).

This technique removes excessive noise from the accelerometer angular measurements while providing a fast and accurate response to angular changes using the gyroscope data.

2.2.4 Tilt and Rotation Angles

The unit calculates: θ – pitch, ϕ – roll, and ρ – gravity angles from the rotation matrix elements.

The pitch and roll angles can be calculated in two different ways: as tilt or rotation angles. The gravity angle is always a tilt angle.

2.2.4.1 Tilt Angles

The pitch and roll tilt angles define the inclination of the unit relatively to the ground plane. The gravity angle defines the inclination of the unit relatively to the gravity vector.

The pitch θ^t and roll ϕ^t tilt angles define the inclination of the unit relatively to the (X_E, Y_E) ground plane parallel to the Earth surface in the Earth frame (X_E, Y_E, Z_E) , see Figure 3. The pitch angle θ^t is an angle between the vertical projection $X_{E(XY)^*}$ of the unit X axis onto the

ground plane and the X axis. Similarly, the roll angle ϕ^t is an angle between the vertical projection $Y_{E(XY)^*}$ of the unit Y axis onto the ground plane and the Y axis.

The angle between the axis projections $X_{E(XY)^*}$ and $Y_{E(XY)^*}$ is not 90° in general case. It is 90° when the unit is parallel and 180° – when perpendicular to the ground plane.

The gravity angle ρ is an angle between the Z_E axis of the Earth frame and the unit Z axis.

The sign of the pitch and roll tilt angles is defined by the right-hand rule and presented by arrows about the Y and X axes. Since the pitch angle θ^t direction in Figure 3 is the same as the positive direction defined by the yellow arrow about the Y axis, the angle is positive. The same way, the roll angle ϕ^t direction is the opposite to the positive direction defined by the green arrow about the X axis. Therefore, the roll angle ϕ^t in Figure 3 is negative.

Pitch and roll tilt angles can be calculated either in the $\pm 90^\circ$ or $\pm 180^\circ$ measurement range depending on the application requirements.

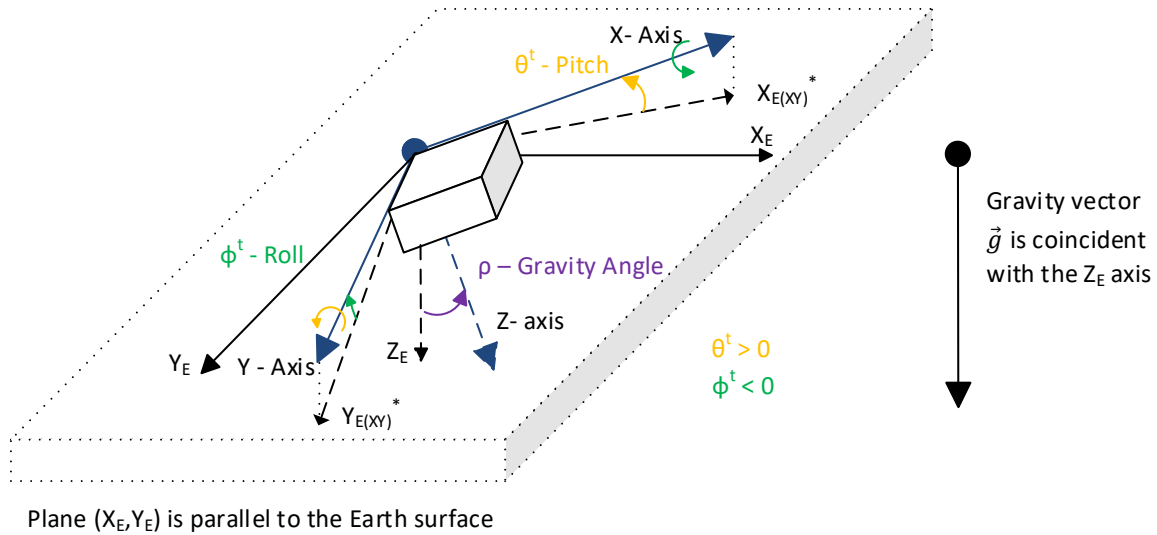

Figure 3. Tilt Angles

In the static condition, for tilt angles in the $\pm 90^\circ$ range:

$$\theta^t = \text{atan2}(-g_x, \sqrt{g_y^2 + g_z^2}), \quad \theta^t \in [-90^\circ; 90^\circ], \quad (5)$$

$$\phi^t = \text{atan2}(g_y, \sqrt{g_x^2 + g_z^2}), \quad \phi^t \in [-90^\circ; 90^\circ],$$

For tilt angles in the $\pm 180^\circ$ range:

$$\theta^t = \text{atan2}(-g_x, \text{sign}(g_z) \cdot \sqrt{g_y^2 + g_z^2}), \quad \theta^t \in [-180^\circ; 180^\circ], \quad (6)$$

$$\phi^t = \text{atan2}(g_y, \text{sign}(g_z) \cdot \sqrt{g_x^2 + g_z^2}), \quad \phi^t \in [-180^\circ; 180^\circ],$$

where: $sign(x) = \begin{cases} -1, & x < 0 \\ 1, & x \geq 0 \end{cases}$

and: $\vec{g} = (g_x, g_y, g_z)$ – measured gravity vector.

When measured in the $\pm 90^\circ$ range, the tilt angles are the angles that a dual-axis inclinometer (or two single-axis inclinometers placed in orthogonal directions) will measure in the same position as the unit. They will not detect a roll-over condition.

To detect a roll-over, the gravity angle can be used. The gravity angle is calculated using the following formula:

$$\rho = \text{atan2}(\sqrt{g_x^2 + g_y^2}, g_z), \quad \rho \in [0^\circ; 180^\circ]. \quad (7)$$

When $\rho > 90^\circ$, the roll-over occurs.

When pitch θ^t and roll ϕ^t angles are measured in the $\pm 180^\circ$ range, the tilt angles will detect a roll-over when: $|\theta^t| > 90^\circ$ or $|\phi^t| > 90^\circ$, but they will lose a smooth angular transition in the roll-over points.

When the unit is parallel to the Earth surface, all tilt angles are zero: $\theta^t = \phi^t = \rho = 0^\circ$.

2.2.4.2 Rotation Angles

In opposite to tilt angles that measure an inclination angle of the unit from a certain reference plane or a vector, the rotation angles measure a rotation angle of the unit about a certain axis.

The unit can measure two types of rotation angles: unit rotation angles and Euler angles.

2.2.4.2.1 Unit Rotation Angles

The unit rotation angles define rotations about the axes in the unit frame (X,Y,Z) the following way, see Figure 4.

The rotation about the Y axis defines the pitch angle θ^u and the rotation about the X axis – the roll angle ϕ^u . The pitch angle θ^u is an angle between the horizontal projection $X_{E(XZ)}^*$ of the unit X axis onto the (X_E, Z_E) plane and the X_E axis. Similarly, the roll angle ϕ^u is an angle between the horizontal projection $Y_{E(YZ)}^*$ of the unit Y axis onto the (Y_E, Z_E) plane and the Y_E axis.

The (X_E, Z_E) and (Y_E, Z_E) planes are perpendicular to the Earth surface (X_E, Y_E) in the Earth frame (X_E, Y_E, Z_E) . The angle between $X_{E(XZ)}^*$ and $Y_{E(YZ)}^*$ is always 90° .

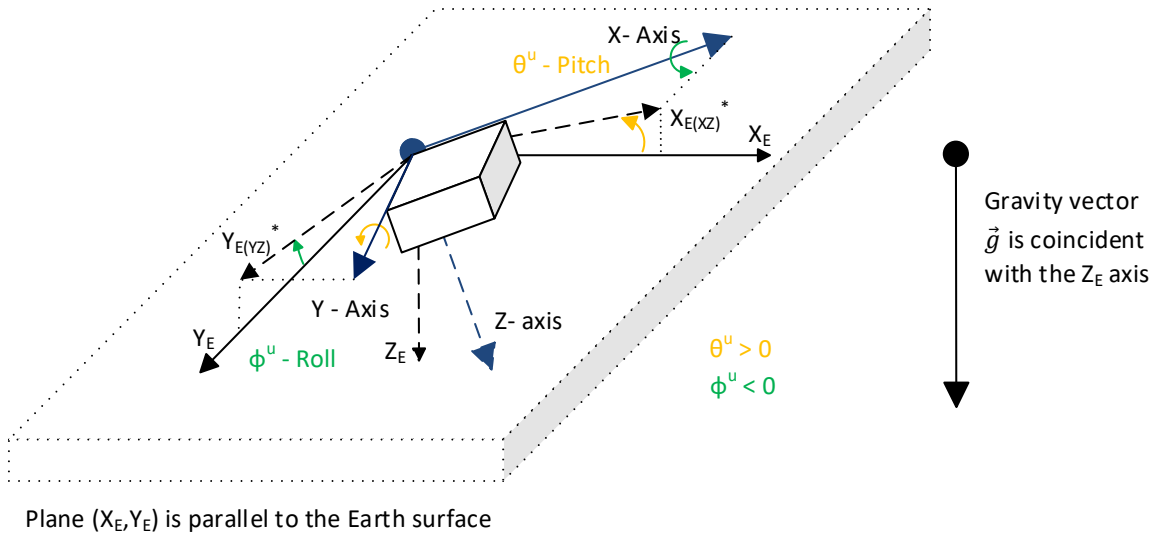

Figure 4. Simple Rotation Angles

The rotation about the Z axis (yaw angle) is not shown in Figure 4. It cannot be calculated based on the gravity acceleration \vec{g} .

The sign of the pitch and roll angles is defined by the right-hand rule and presented by arrows about the Y and X axes. Since the pitch angle θ^u direction in Figure 4 is the same as the positive direction defined by the yellow arrow about the Y axis, the angle is positive. The same way, the roll angle ϕ^u direction is the opposite to the positive direction defined by the green arrow about the X axis. Therefore, the roll angle ϕ^u in Figure 4 is negative.

In the static condition, the unit rotation angles are calculated using the following formulas:

$$\theta^u = \text{atan2}(-g_x, g_z), \quad \theta^u \in [-180^\circ; 180^\circ], \quad (8)$$

$$\phi^u = \text{atan2}(g_y, g_z), \quad \phi^u \in [-180^\circ; 180^\circ],$$

where: $\vec{g} = (g_x, g_y, g_z)$ – gravity vector measured by the unit.

The roll-over condition is observed when: $|\theta^u| > 90^\circ$ or $|\phi^u| > 90^\circ$.

When the unit is parallel to the Earth surface, the unit rotation angles are zero: $\theta^u = \phi^u = 0^\circ$.

The unit rotation angles do not uniquely define the unit angular position in space. If this is required, the Euler angles should be used.

2.2.4.2.2 Euler Angles

The Euler angles are coordinate system rotation angles performed in a specific order to rotate the unit from its original position, parallel to the Earth surface, to its current position.

The Euler angles: θ^E and ϕ^E , together with the ψ^E , are rotation angles about the Z_E , Y_E^* and X axes performed in a standard (yaw, pitch, roll) rotation sequence used in aerospace and defined in SAE J670 standard for automotive applications, see Figure 5.

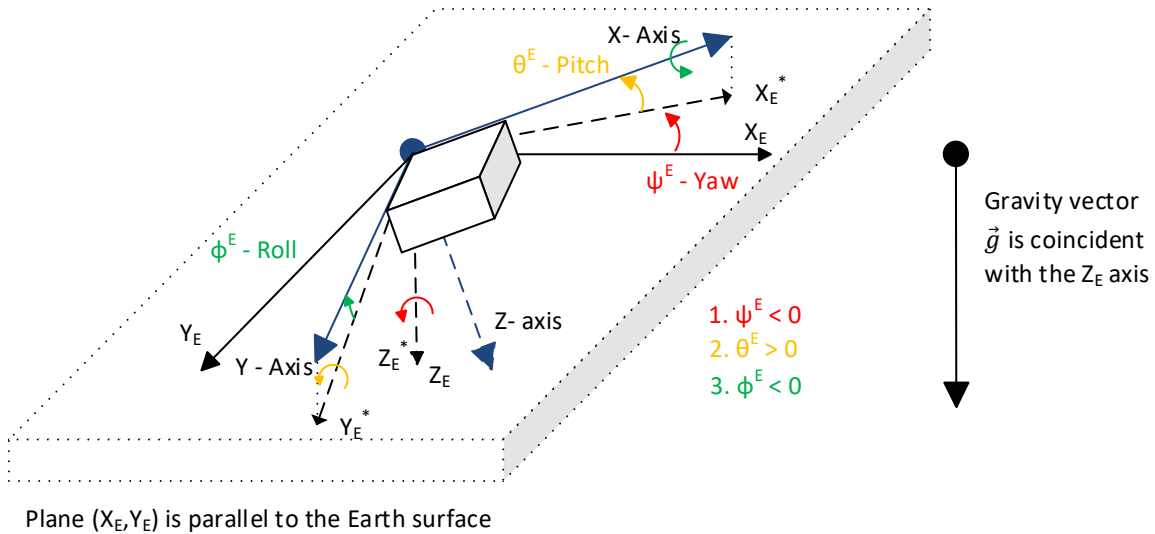

Figure 5. Euler Angles

The first rotation defines the ψ^E – yaw angle. It is performed about the Z_E axis of the Earth-fixed coordinate system (X_E, Y_E, Z_E) from the X_E axis to the X_{E^*} axis. An intermediate coordinate system ($X_{E^*}, Y_{E^*}, Z_{E^*}$) is a Z-down coordinate system whose X_{E^*} and Y_{E^*} axes are parallel to the ground plane (X_E, Y_E), with the X_{E^*} axis aligned with the vertical projection of the X axis onto the ground plane. Since the yaw rotation ψ^E on Figure 5 is opposite to the positive rotation direction, shown by the red arrow about the Z_E axis, the resulted angle is negative.

The second rotation defines the θ^E – pitch angle. It is performed about the Y_{E^*} axis of the intermediate coordinate system ($X_{E^*}, Y_{E^*}, Z_{E^*}$) from the X_{E^*} axis to the X axis. The pitch rotation θ^E on Figure 5 is in the positive rotation direction, defined by the yellow arrow about the Y_{E^*} axis, and the resulted angle is therefore positive.

The final third rotation defines the ϕ^E – roll angle, as a rotation about the X axis from the Y_{E^*} axis to the Y axis. The roll rotation ϕ^E on Figure 5 is negative. It is performed in the direction opposite to the positive rotation direction shown by the green arrow about the X axis.

The set of the three: yaw, pitch, and roll Euler angles fully represents the angular position of the inclinometer in space.

In the static condition, the Euler angles are calculated using the following formulas:

$$\theta^E = \text{atan2}(-g_x, \sqrt{g_y^2 + g_z^2}), \quad \theta^E \in [-90^\circ; 90^\circ], \quad (9)$$

$$\phi^E = \text{atan2}(g_y, g_z), \quad \phi^E \in [-180^\circ; 180^\circ],$$

where: $\vec{g} = (g_x, g_y, g_z)$ – measured gravity vector.

There is not enough information for the unit to calculate the yaw angle based only on the measured gravity vector in the static condition.

The roll angles for both: the unit rotation and Euler angles are the same: $\phi^u = \phi^E$.

The roll-over condition is observed when: $|\phi^E| > 90^\circ$.

When the unit is parallel to the Earth surface, the Euler angles are zero: $\theta^E = \phi^E = 0^\circ$.

2.2.4.2.3 Gimbal Lock

The formulas for the roll angle ϕ^E and ϕ^u are numerically unstable when both: $g_y = g_z = 0$. This condition, called a gimbal lock, happens when the unit is placed in the vertical position with the X axis parallel to the gravity vector, see Figure 6. When this happens, the unit effectively loses one degree of freedom and the roll angles ϕ^E and ϕ^u become undefined and can take any random value.

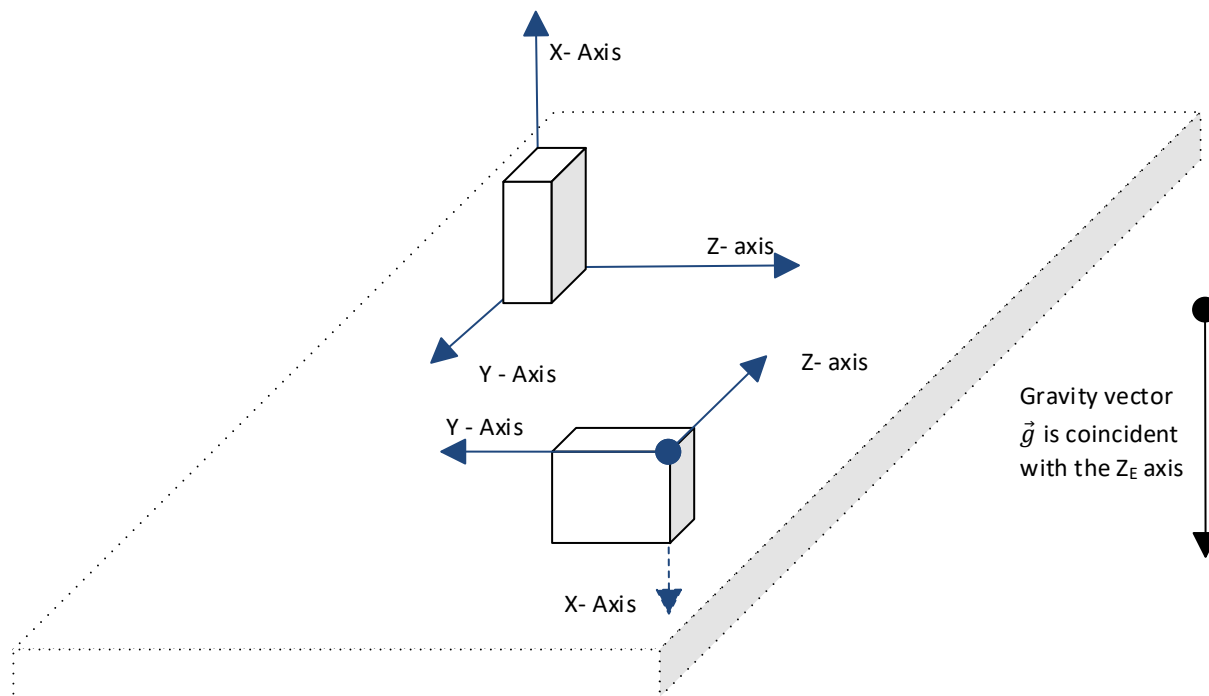

Plane (X_E, Y_E) is parallel to the Earth surface

Figure 6. Gimbal Lock

The same condition occurs with the pitch angle θ^u when both: $g_x = g_z = 0$.

The gimbal lock should be avoided in the inclinometer initial installation position. It should be also avoided in the inclinometer working range when it leads to unstable angular measurements.

The user can avoid the gimbal lock condition by changing orientation of the unit frame (a coordinate system attached to the unit) using configuration parameters when necessary. This approach works well for 3-axis gyroscope modifications or when the dynamic gyroscope compensation is disabled.

In single-axis gyroscope modifications the unit frame rotation should be used with extra caution since the gyroscope senses angular rate in the predefined physical direction, which cannot be changed by the unit frame rotation.

2.2.4.3 Maximum Gravity Acceleration Error

All angular measurements in the static condition are based on the assumption that the only acceleration applied to the unit is the gravity acceleration \vec{g} , see (2). This is not entirely true when the inclinometer is installed on a moving machine and is experiencing various external accelerations. These accelerations will affect the angular calculations and, at some point, will make the accuracy of the calculations unacceptable.

To monitor the validity of the angular calculations, the inclinometer is calculating the *Gravity Acceleration Error* δ_g as a difference between the measured gravity acceleration \vec{g} and its expected theoretical value:

$$\delta_g = \left| 1 - \sqrt{g_x^2 + g_y^2 + g_z^2} \right| \quad (10)$$

When the difference exceeds a predefined value $\delta_g > \delta_g^{(max)}$, the angular calculations are considered invalid and the inclinometer sets the error state in the [Angular Figure of Merit](#).

The *Maximum Gravity Acceleration Error* $\delta_g^{(max)}$ is set by the user normally above the expected external accelerations at the customer site during normal operation conditions.

Please remember that even when $\delta_g \leq \delta_g^{(max)}$, the rated inclinometer static parameters including accuracy are not guaranteed during external accelerations. The $\delta_g^{(max)}$ only sets a threshold to notify the user that the external accelerations are too high for the angular measurements.

The *Maximum Gravity Acceleration Error* $\delta_g^{(max)}$ is not used to void the angular measurement results when the inclinometer angles are calculated using the sensor fusion algorithm combining static and dynamic measurements. Nevertheless, when the sensor fusion is temporarily disabled, for example due to a gyroscope saturation, the $\delta_g^{(max)}$ is used to check the validity of the inclinometer data.

2.2.4.4 Practical Recommendations

At the beginning, the user defines an inclinometer position on the machine, direction of the measurement angle or two angles in orthogonal directions, and the angular ranges.

It is important to understand that the inclinometer calculates angles based on the gravity acceleration and the angles are measured between the inclinometer unit frame or machine frame and the Earth absolute reference frame (X_E, Y_E, Z_E) where the gravity acceleration vector is uniquely defined.

The inclinometer can measure only pitch θ and roll ϕ angles. It cannot measure the yaw angle ψ , since the yaw angle is in the plane perpendicular to the gravity acceleration in the Earth absolute reference frame (X_E, Y_E, Z_E) and therefore cannot be detected by an accelerometer.

The user starts with aligning the inclinometer unit frame with the Earth absolute reference frame at the inclinometer expected position on the machine. This is done by pointing the unit frame Z-axis down, making it coincident with the gravity acceleration vector, and then aligning the unit pitch θ and roll ϕ angles with the required measurement angles.

In 3-axis gyroscope modifications, the user can do this alignment either by mechanically rotating the inclinometer housing on the machine or by changing the unit frame orientation using inclinometer configuration parameters.

In single-axis gyroscope modifications, the inclinometer housing should be mechanically rotated to align the required measurement angle with the direction of the gyroscope measurements.

After the inclinometer position and the unit frame orientation are defined, the user should choose the type of the angles, since both: tilt and rotation angles have their pros and cons for angular measurements.

Table 1. Tilt and Rotation Angles

| Inclination Angles | Advantages | Disadvantages |
|-----------------------------|---|--|
| Tilt, $\pm 90^\circ$ Range | <ul style="list-style-type: none"> Numerically stable in the whole angular range. Smooth angular transition inside the measurement range. | <ul style="list-style-type: none"> $\pm 90^\circ$ range for pitch and roll angles. No roll-over detection. |
| Tilt, $\pm 180^\circ$ Range | <ul style="list-style-type: none"> Numerically stable in the whole angular range. $\pm 180^\circ$ range for pitch and roll angles. Roll-over detection. | <ul style="list-style-type: none"> Abrupt angular transition inside the measurement range in roll-over points. |
| Unit Rotation Angles | <ul style="list-style-type: none"> Smooth angular transition inside the measurement range, except for the gimbal lock points. $\pm 180^\circ$ range for pitch and roll angles. Roll-over detection. | <ul style="list-style-type: none"> Numerically unstable pitch and roll angles in gimbal lock points. |
| Euler Angles | <ul style="list-style-type: none"> Smooth angular transition inside the measurement range, except for the roll angle in gimbal lock points. $\pm 180^\circ$ range for the roll angle; Roll-over detection. Uniquely define the unit angular position in space. | <ul style="list-style-type: none"> $\pm 90^\circ$ range for pitch angle to avoid ambiguity in angular rotations. Numerically unstable roll angle in gimbal lock points. |

For single and dual-axis measurements, when the measurement range is not above $\pm 90^\circ$, the tilt angles in the $\pm 90^\circ$ range are recommended, see Figure 7 and Figure 8. They are numerically stable and have a smooth angular transition inside the measurement range. If necessary, the roll-over can be monitored by the gravity angle.

For single-axis measurements, when the measurement range is above $\pm 90^\circ$, the rotation angles are recommended. For unit rotation angles, either pitch or roll angle can be used depending on the position of the unit on the machine. For Euler angles, the roll angle can be used, since it covers the entire $\pm 180^\circ$ range.

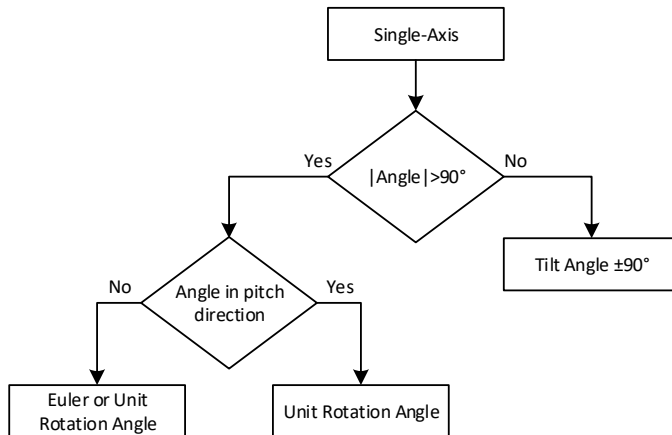

Figure 7. Single-Axis Measurements

For dual-axis measurements with the measurement range above $\pm 90^\circ$, both: tilt angles in the $\pm 180^\circ$ range or rotation angles can be used, see Figure 8. If a smooth angular transition inside the measurement range is not necessary, the tilt angles in the $\pm 180^\circ$ range are recommended due to their numerical stability in the whole measurement range.

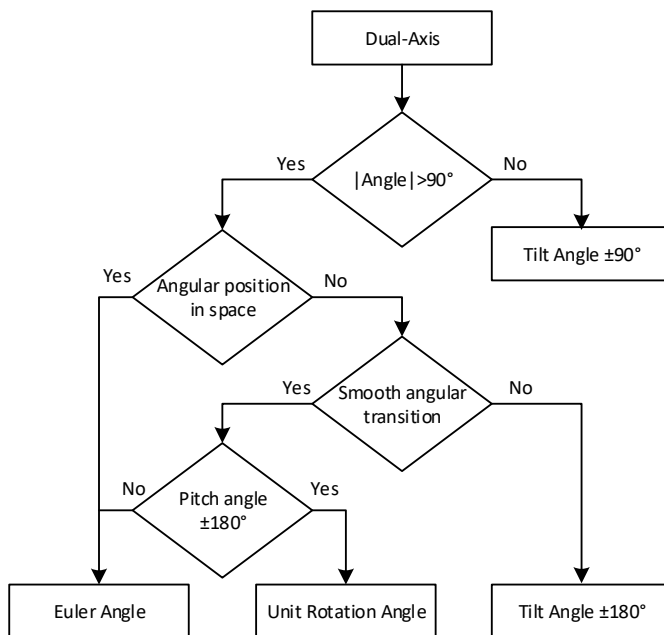

Figure 8. Dual-Axis Measurements

In case it is necessary to get the $\pm 180^\circ$ range for both: pitch and roll angles with a smooth angular transition, the unit rotation angles should be used. Otherwise, the Euler angles are preferred, since they have a gimbal lock only for the roll angle, the pitch angle is numerically stable in the whole measurement range.

The Euler angles are the angles of choice when it is necessary to define the unit angular position in space. The yaw angle is then determined by an external magnetic or GPS sensor.

Even when the Euler angles are not used to calculate the pitch and roll angles, they are still used internally to compensate the unit initial installation angles.

2.2.4.5 Default Settings

Inclinometers AX060900 and AX060910 measure tilt angles in the $\pm 180^\circ$ range by default.

The single-axis gyro modifications: AX062008, AX062018, designed for single-axis measurements in the roll angular direction, measure Euler angles by default.

2.3 Hardware Block Diagram

The inclinometers, depending on configuration, contain one or two three-axis MEMS accelerometers, and one or three single-axis MEMS gyroscopes sensing angular rates in three orthogonal directions, see Figure 9.

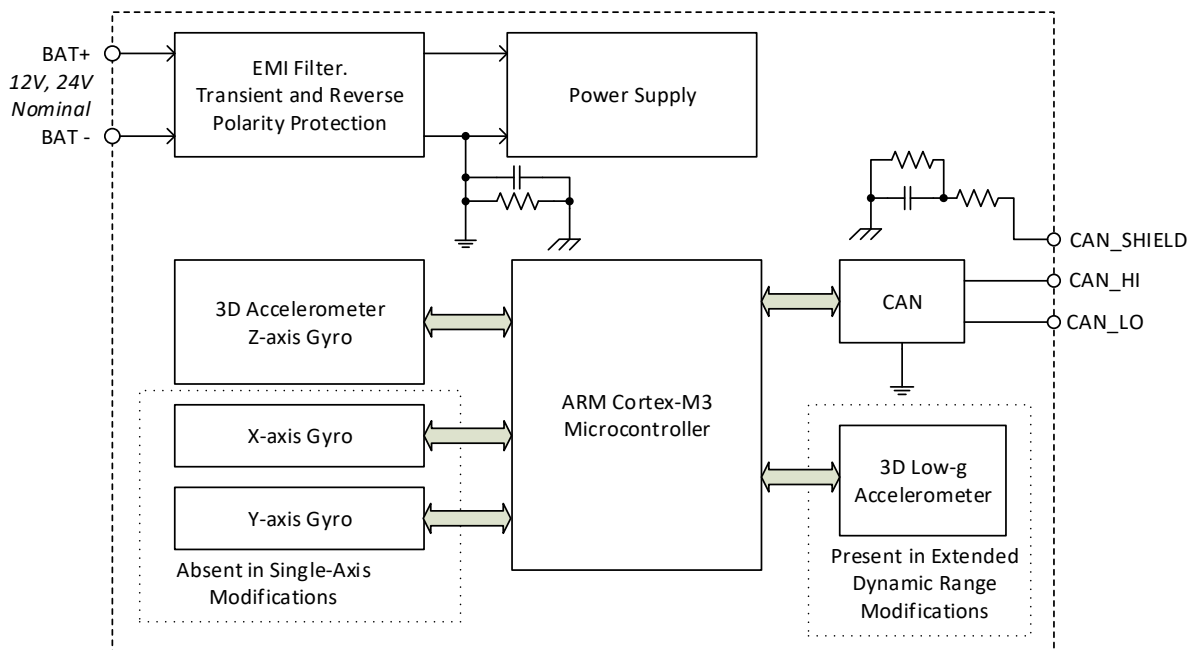

Figure 9. Simplified Inclinometer Hardware Block Diagram

The single-axis gyro inclinometers do not contain X-axis and Y-axis gyroscope sensors. They use a Z-axis gyroscope sensor from an accelerometer-gyroscope combo chip.

The extended dynamic range inclinometers have a dedicated 3D low-g accelerometer to accurately measure inclination angles in the static condition.

The outputs of MEMS accelerometers and gyroscopes are processed by a 32-bit microcontroller to calculate the unit accelerations, angular rates, and inclination angles. The inclination angles are then output to CAN bus together with all other necessary additional information.

The inclinometer has a wide range of protection features including a transient and reverse polarity protection, see [Technical Specifications](#) section.

2.4 Software Organization

2.4.1 Angular Measurements

The inclinometer software block diagram for measuring angles, accelerations, and angular rates is presented in Figure 10.

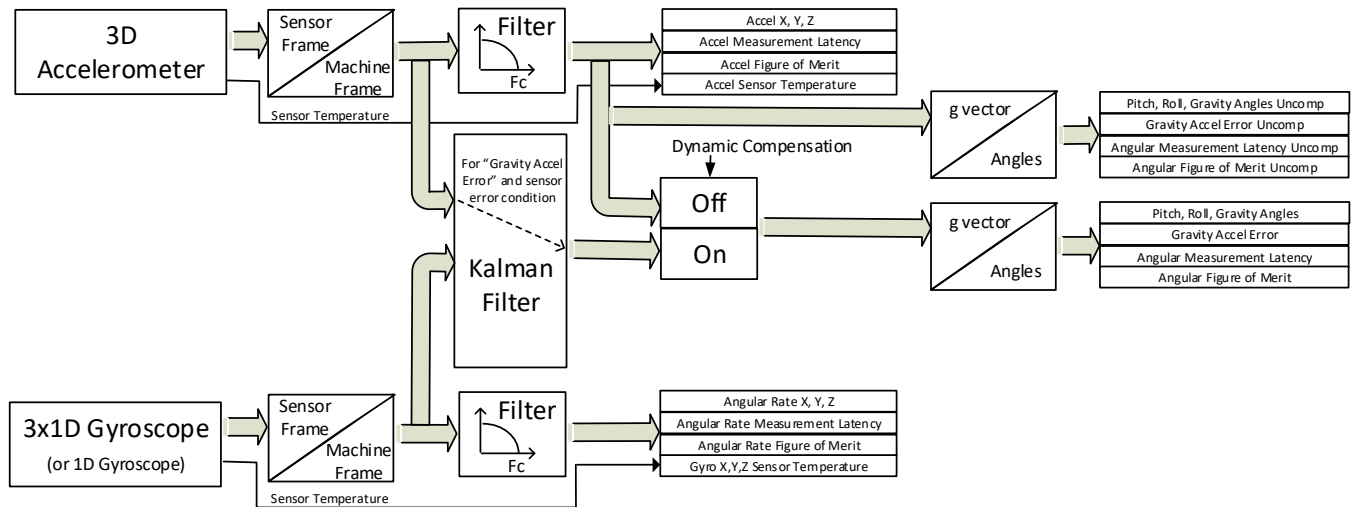

Figure 10. Software Block Diagram for Angular Measurements

A separate 3D low-g accelerometer is used in extended dynamic range inclinometer modifications. Its signal is combined with a regular 3D accelerometer to increase the dynamic range of accelerations and improve the accuracy of static angular measurements, see Figure 11.

The unit accelerations and angular rates from accelerometers and gyroscopes are first converted to the machine frame. Then the acceleration and angular rate signals go through the low pass filters and are output separately in two sets of data, one representing acceleration and the other one – the angular rate of the unit.

The unit angles are measured with or without dynamic compensation. When the dynamic compensation is on, the Kalman Filter is used to combine accelerations with the angular rates to estimate the gravity vector used for angular calculations. When the dynamic compensation is off, the filtered accelerometer signals define the gravity vector and are used to calculate the unit angles.

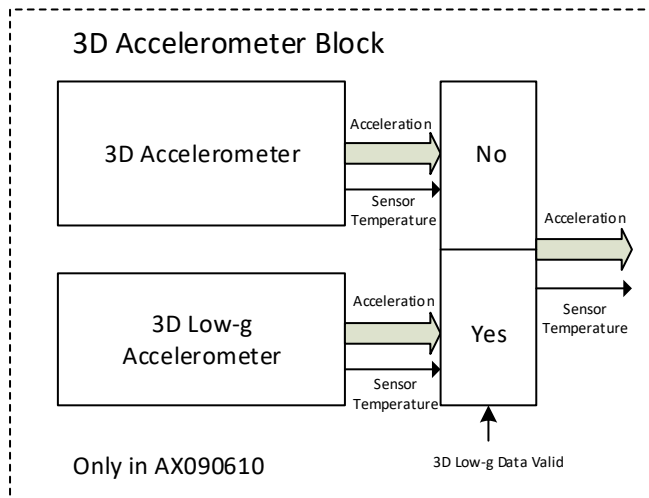

Figure 11. Acceleration Data Collection with Low-g Accelerometer

Even when the dynamic compensation is on, the Kalman Filter might be temporarily disabled due to the sensor saturation or other malfunction. In this case, the unfiltered accelerometer signals are used for angular calculations until the Kalman Filter is ready to take over the gravity vector calculations to define the unit angles.

An auxiliary set of uncompensated angular measurements, calculated on the base of the filtered accelerometer signals, is provided to evaluate the efficiency of the Kalman Filter in real time. When the dynamic compensation is off, the uncompensated angular measurements are the same as the regular angular measurements.

2.4.2 Configurable Internal Architecture

The inclinometer belongs to a family of Axiomatic smart controllers with configurable internal architecture. This architecture allows building a controlling algorithm using a set of internal configurable function blocks without the need of a custom software.

The inclinometer data acquisition and angular measurement internal software structure, shown in Figure 10, is presented in [Accelerometer](#), [Gyroscope](#), and [Angle Measurement](#) function blocks.

The various function blocks supported by the inclinometer are outlined in the following sections. All objects are user configurable using standard commercially available tools that can interact with a CANopen[®] Object Dictionary via an *EDS* file.

The inclinometer application firmware can be also updated in the field using EA, see [Flashing New Firmware](#) section.

3 INCLINOMETER LOGICAL STRUCTURE

The inclinometer is internally organized as a set of function blocks, which can be individually configured and arbitrarily connected together to achieve the required inclinometer functionality, see Figure 12.

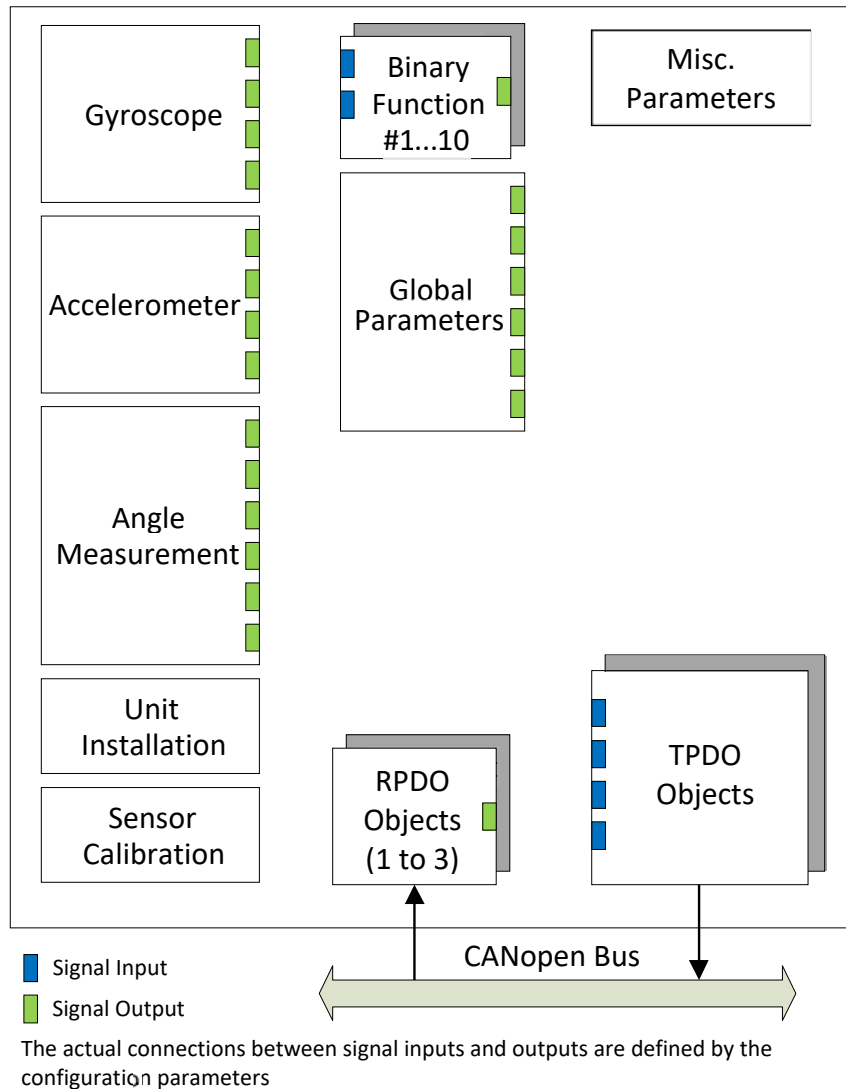

Figure 12. The Inclinometer Logical Block Diagram

Each function block is absolutely independent and has its own set of configuration objects. The objects can be viewed and changed through CANopen protocol.

Gyroscope and accelerometer sensors are presented by *Gyroscope* and *Accelerometer* function blocks, respectively. *Angle Measurement* function block controls measurements of the inclination angles. *Unit Installation* function block is used to compensate installation angles after the unit is mounted at a customer's site. *Sensor Calibration* is an auxiliary function block representing the inclinometer calibration parameters.

In case the inclinometer data need to be processed before been output, the unit has ten *Binary Function* blocks to do simple data conversion operations.

The inclinometer also has a *Global Parameters* function block containing four constant output signals and other auxiliary output signals. The *Miscellaneous Parameters* function block contains various parameters used to help configure and control the unit.

3.1 Function Block Signals

The inclinometer function blocks can contain signal inputs and outputs to communicate with each other. Each signal input can be connected to any signal output using an appropriate configuration parameter. There is no limitation on the number of signal inputs connected to a signal output.

When a signal input is connected to a signal output, data from the signal output of one function block is available on the signal input of another function block. The function block signal data can have the following signal types: {*Undefined*, *Discrete* or *Continuous*}.

3.1.1 Undefined Signal

The *Undefined* signal type is used to present a no-signal condition in signal data or to specify that the signal input is not connected (not used).

3.1.2 Discrete Signal

The *Discrete* signal type is used to present a discrete signal that has a finite number of states in signal data or to specify that the signal input or output is communicating this type of signals.

The discrete signals are stored in four-byte unsigned integer variables that can present any state value in the $0 \dots 0xFFFFFFFF$ range.

3.1.3 Continuous Signal

The *Continuous* signal type presents continuous signals, usually physical parameters, in signal data or as a signal input or output type.

The continuous signals are stored in floating point variables. They are not normalized and present data in the appropriate physical units. The user can do simple scaling of the continuous signal data by changing *Scale (Resolution)* and *Offset* configuration parameters in the appropriate function blocks.

3.1.4 Signal Type Conversion

Discrete and *Continuous* signals are automatically converted into each other when a signal input of one signal type is connected to a signal output of a different signal type.

3.1.4.1 Discrete to Continuous Conversion

A *Discrete* signal is converted into a positive *Continuous* signal of the same value.

3.1.4.2 Continuous to Discrete Conversion

A positive *Continuous* signal is converted into the same value *Discrete* signal. A fractional part of the *Continuous* signal is truncated. If the *Continuous* signal value is above the maximum

Discrete signal value, the resulted *Discrete* signal value will saturate to the maximum *Discrete* signal value: *0xFFFFFFFF*. All negative *Continuous* signals are converted into zero value *Discrete* signals.

3.1.4.3 Undefined Signal Conversion

An *Undefined* signal is not converted into a specific discrete or continuous signal value. It presents a no-signal condition on both: *Discrete* and *Continuous* signal inputs and outputs. The value of an undefined signal is not defined unless a default signal value configuration parameter is used in a function block. In this case, the configuration parameter value is used as a signal value when the signal is not defined, see [Binary Function](#) blocks.

3.1.5 Function Block Signal/Control Source List

Table 4 lists the Function Block Signals/Control Sources that can be selected for any of the application data function blocks.

Table 2. Function Block Signal/Control Source List

| | Signal |
|----|---|
| 0 | No Source |
| 1 | Angular Rate X |
| 2 | Angular Rate Y |
| 3 | Angular Rate Z |
| 4 | Angular Rate Measurement Latency |
| 5 | Angular Rate Figure of Merit |
| 6 | Gyroscope Sensor X Temperature |
| 7 | Gyroscope Sensor Y Temperature |
| 8 | Gyroscope Sensor Z Temperature |
| 9 | Accelerometer X-Axis Data |
| 10 | Accelerometer Y-Axis Data |
| 11 | Accelerometer Z-Axis Data |
| 12 | Accelerometer Measurement Latency |
| 13 | Accelerometer Figure of Merit |
| 14 | Accelerometer Sensor Temperature |
| 15 | Pitch Angle Uncompensated Data |
| 16 | Roll Angle Uncompensated Data |
| 17 | Gravity Angle Uncompensated Data |
| 18 | Gravity Acceleration Error Uncompensated |
| 19 | Angular Measurement Latency Uncompensated |
| 20 | Angular Figure of Merit Uncompensated |
| 21 | Pitch Angle Data |

| | |
|-------|-----------------------------|
| 22 | Roll Angle Data |
| 23 | Gravity Angle Data |
| 24 | Gravity Acceleration Error |
| 25 | Angular Measurement Latency |
| 26 | Angular Figure of Merit |
| 27 | Angle Compensation |
| 28 | Angle Compensation Inverted |
| 29... | Binary Function 1 |
| ...38 | Binary Function 10 |
| 39... | CAN Input 1 |
| ...41 | CAN Input 3 |
| 42 | Constant Discrete Data |
| 43 | Constant Continuous Data |
| 44 | Constant Zero/FALSE Signal |
| 45 | Constant One/TRUE Signal |
| 46 | Power Supply Measured |
| 47 | Temperature Measured |

In addition to a source, each control also has a number which corresponds to the sub-index of the function block in question. Table 5 outlines the ranges supported for the number of objects, depending on the source that had been selected.

Table 3. Function Block Signal/Control Source Range with Respective CANopen Object

| Control Source | Range | Object (Meaning) |
|-----------------------------------|-------|---------------------------------|
| Control Source Not Used/Undefined | 0 | Ignored |
| Angular Rate Data | 1 | 4100h sub-index 1 (X-Axis Data) |
| | 2 | 4100h sub-index 2 (Y-Axis Data) |
| | 3 | 4100h sub-index 3 (Z-Axis Data) |
| Angular Rate Measurement Latency | N/A | 4110h sub-index 0 |
| Angular Rate Figure of Merit | N/A | 4120h sub-index 0 |
| Gyroscope Sensor Temperature Data | 1 | 4150h sub-index 1 (X-Axis Data) |
| | 2 | 4150h sub-index 2 (Y-Axis Data) |
| | 3 | 4150h sub-index 3 (Z-Axis Data) |
| Accelerometer Data | 1 | 4000h sub-index 1 (X-Axis Data) |
| | 2 | 4000h sub-index 2 (Y-Axis Data) |
| | 3 | 4000h sub-index 3 (Z-Axis Data) |
| Accelerometer Measurement Latency | N/A | 4010h sub-index 0 |

| | | |
|---|-----|--|
| Accelerometer Figure of Merit | N/A | 4020h sub-index 0 |
| Accelerometer Sensor Temperature | N/A | 4060h sub-index 0 |
| Angular Measurement Uncompensated Data | N/A | 4220h sub-index 0 (Pitch Data) |
| | N/A | 4230h sub-index 0 (Roll Data) |
| | N/A | 4240h sub-index 0 (Gravity Data) |
| Gravity Acceleration Error Uncompensated | N/A | 4250h sub-index 0 |
| Angular Measurement Latency Uncompensated | N/A | 4200h sub-index 0 |
| Angular Figure of Merit Uncompensated | N/A | 4210h sub-index 0 |
| Angular Measurement Data | N/A | 4030h sub-index 0 (Pitch Angle Data) |
| | N/A | 4040h sub-index 0 (Roll Angle Data) |
| | N/A | 4050h sub-index 0 (Gravity Angle Data) |
| Gravity Acceleration Error | N/A | 4060h sub-index 0 |
| Angular Measurement Latency | N/A | 4130h sub-index 0 |
| Angular Figure of Merit | N/A | 4140h sub-index 0 |
| Angle Compensation | N/A | 4080h sub-index 0 |
| Angle Compensation Inverted | N/A | 4090h sub-index 0 |
| Binary Function Block | 1 | 3000h sub-index 1 (Bin Function 1 Out) |
| | 2 | 3000h sub-index 2 (Bin Function 2 Out) |
| | 3 | 3000h sub-index 3 (Bin Function 3 Out) |
| | 4 | 3000h sub-index 4 (Bin Function 4 Out) |
| | 5 | 3000h sub-index 5 (Bin Function 5 Out) |
| | 6 | 3000h sub-index 6 (Bin Function 6 Out) |
| | 7 | 3000h sub-index 7 (Bin Function 7 Out) |
| | 8 | 3000h sub-index 8 (Bin Function 8 Out) |
| | 9 | 3000h sub-index 9 (Bin Function 9 Out) |
| | 10 | 3000h sub-index 10 (Bin Function 10 Out) |
| CANopen Message (RPDO) | 1 | 2500h sub-index 1 (Extra Received PV 1) |
| | 2 | 2500h sub-index 2 (Extra Received PV 2) |
| | 3 | 2500h sub-index 3 (Extra Received PV 3) |
| Global Parameter Function Block | N/A | 4260h sub-index 0 (Continuous Signal) |
| | N/A | 4270h sub-index 0 (Discrete Signal) |
| Power Supply Measured | N/A | 5000h sub-index 0 |
| Temperature Measured | N/A | 5010h sub-index 0 |

3.2 Gyroscope

The *Gyroscope* function block presents all three gyroscope MEMS sensors sensing inclinometer angular rate in three orthogonal directions (3D)¹.

¹In single-axis modifications, this function block presents only one gyroscope sensing angular rate in X direction.

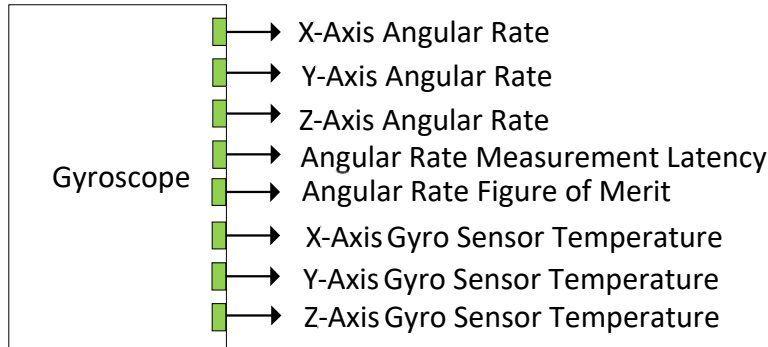

Figure 13. Gyroscope Function Block

3.2.1 Gyroscope Signals

This function block has 8 signal outputs. The *X, Y, Z - Axis Angular Rate* continuous signals represent the gyroscope angular rates about the appropriate axis in the machine frame in [deg/s]. The machine frame is coincident with the unit frame by default when the initial pitch and roll angles are zero in the [Unit Installation](#) function block.

The *Angular Rate Measurement Latency* continuous signal defines the angular rate measurement latency in [ms].

The *Angular Rate Figure of Merit* discrete signal defines whether the gyroscope angular rate data can be trusted. It has the following set of states:

Table 4. Gyroscope Angular Rate Figure of Merit

| State | Description |
|-------|---|
| 0 | All gyroscopes are fully functional. Data is within the sensor specification. |
| 1 | Data is suspect due to environmental conditions. Set when any of the gyroscope sensor temperatures is less than -40°C or greater than +125°C. |
| 2 | Error condition has been detected. |

The *X, Y, Z - Axis Gyro Sensor Temperature* continuous signals represent the internal temperatures for each individual gyroscope sensor in [°C]¹.

¹In single-axis gyro modifications, since only Z-axis gyro is present, *X, Y - Axis Gyro Sensor Temperatures* are equal to *Z - Axis Gyro Sensor Temperature*.

The CANopen information about the signals associated with the *Gyroscope* function block is listed below.

Table 5. Gyroscope Signals CANopen Information

| Name | Index | Subindex | Data Type | Access | PDO Mapping | Value Range | Default Value |
|------------------------------------|-------|----------|-----------|--------|-------------|-------------|---------------|
| <i>Gyroscope Angular Rate Data</i> | 4100 | 0 | UINT8 | RO | No | 3 | 3 |
| Pitch Angle Rate Field Value | | 1 | INT16 | RO | Yes | | 0 |
| Roll Angle Rate Field Value | | 2 | | | | | |
| Yaw Angle Rate Field Value | | 3 | | | | | |
| Angular Rate Measurement Latency | 4110 | 0 | UINT16 | RO | Yes | UINT16 | 0 |
| Angular Rate Figure of Merit | 4120 | 0 | UINT8 | RO | Yes | {0, 1, 2} | 0 |
| <i>Gyroscope Temperature Data</i> | 4150 | 0 | UINT8 | RO | No | 3 | 3 |
| X-Axis Sensor Temperature | | 1 | INT16 | RO | Yes | | 0 |
| Y-Axis Sensor Temperature | | 2 | | | | | |
| Z-Axis Sensor Temperature | | 3 | | | | | |

3.2.2 Gyroscope Configuration Parameters

This function block also has configuration parameters to control the operation of the *Gyroscope*. The *Input Filter Enable* parameter enables the low-pass input filter when set to 1 and disables it when set to 0. The *Input Filter Cut-Off Frequency* set the cut-off frequency of the filter if it is enabled.

The CANopen information about the parameters associated with the *Gyroscope* function block is listed below.

Table 6. *Gyroscope Configuration Parameters CANopen Information*

| Name | Index | Subindex | Data Type | Access | PDO Mapping | Value Range | Default Value |
|--|-------|----------|-----------|--------|-------------|-------------|---------------|
| Gyro Sensor Input Filter Enable | 2002 | 0 | UINT8 | RW | No | {0, 1} | 1 |
| Gyro Sensor Input Filter Cut-off Frequency | 2003 | 0 | UINT8 | RW | No | [1...35] | 5 |

3.3 Accelerometer

The *Accelerometer* function block represents the 3D accelerometer sensor.

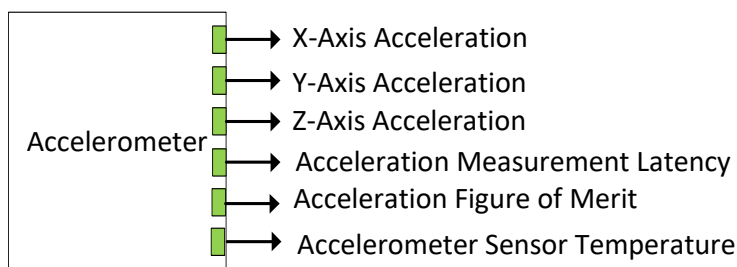

Figure 14. *Accelerometer Function Block*

3.3.1 Accelerometer Signals

The *Accelerometer* function block has 6 signal outputs. The unit accelerations: *X, Y, Z - Axis Acceleration* are presented in gravity units [g] in the machine frame. The machine frame is coincident with the unit frame by default when the initial pitch and roll angles are zero in the [Unit Installation](#) function block.

The *Acceleration Measurement Latency* continuous signal defines the acceleration measurement latency in [ms].

The *Acceleration Rate Figure of Merit* discrete signal defines whether the acceleration data can be trusted. It has the following set of states:

Table 7. Gyroscope Angular Rate Figure of Merit

| State | Description |
|-------|---|
| 0 | Accelerometer is fully functional. Data is within the sensor specification. |
| 1 | Data is suspect due to environmental conditions. Set when the accelerometer sensor temperature is less than -40°C or greater than +125°C. |
| 2 | Error condition has been detected. |

The *Accelerometer Sensor Temperature* output represents the 3D accelerometer sensor temperature in [°C].

The CANopen information about the signals associated with the *Accelerometer* function block is listed below.

Table 8. Accelerometer Signals CANopen Information

| Name | Index | Subindex | Data Type | Access | PDO Mapping | Value Range | Default Value |
|-----------------------------------|-------|----------|-----------|--------|-------------|-------------|---------------|
| <i>Accelerometer Data</i> | 4000 | 0 | UINT8 | RO | No | 3 | 3 |
| X-Axis Acceleration Field Value | | 1 | INT16 | RO | Yes | | 0 |
| Y-Axis Acceleration Field Value | | 2 | | | | | |
| Z-Axis Acceleration Field Value | | 3 | | | | | |
| Accelerometer Measurement Latency | 4010 | 0 | UINT16 | RO | Yes | UINT16 | 0 |
| Accelerometer Figure of Merit | 4020 | 0 | UINT8 | RO | Yes | {0, 1, 2} | 0 |
| Accelerometer Sensor Temperature | 4070 | 1 | INT16 | RO | Yes | | 0 |

3.3.2 Accelerometer Configuration Parameters

This function block also has configuration parameters to control the operation, and format the data of the *Accelerometer*. The *Input Filter Enable* parameter enables the low-pass input filter when set to 1 and disables it when set to 0. The *Input Filter Cut-Off Frequency* set the cut-off frequency of the filter if it is enabled.

The *Data Resolution*, *Data Inversion*, *Data Offset* and parameters configure the output signals for the corresponding *Accelerometer Data* signal. These parameters affect the signal in the following manner:

$$Output = ((Input \times (-1 \times Inversion)) + Offset) \times \frac{1000}{Resolution}$$

The CANopen information about the parameters associated with the *Accelerometer* function block is listed below.

Table 9. Accelerometer Configuration Parameters CANopen Information

| Name | Index | Subindex | Data Type | Access | PDO Mapping | Value Range | Default Value |
|--|-------|----------|-----------|--------|-------------|-------------|---------------|
| Accelerometer Sensor Input Filter Enable | 2004 | 0 | UINT8 | RW | No | {0, 1} | 1 |

| | | | | | | | |
|---|------|---|---------|----|----|------------|------|
| Accelerometer Sensor Input Filter Cut-off Frequency | 2005 | 0 | UINT8 | RW | No | [1...35] | 5 |
| Accelerometer Data Resolution | 2010 | 0 | UINT16 | RW | No | [1...1000] | 1000 |
| X-Axis Resolution | | 1 | | | | | |
| Y-Axis Resolution | | 2 | | | | | |
| Z-Axis Resolution | | 3 | | | | | |
| Accelerometer Data Inversion | 2011 | 0 | UINT8 | RW | No | {0, 1} | 0 |
| X-Axis Inversion | | 1 | | | | | |
| Y-Axis Inversion | | 2 | | | | | |
| Z-Axis Inversion | | 3 | | | | | |
| Accelerometer Data Offset | 2020 | 0 | FLOAT32 | RW | No | FLOAT32 | 0 |
| X-Axis Offset | | 1 | | | | | |
| Y-Axis Offset | | 2 | | | | | |
| Z-Axis Offset | | 3 | | | | | |

3.4 Angle Measurement

The *Angle Measurement* function block calculates pitch, roll and gravity angles in the machine frame, see Figure 15. The machine frame is coincident with the unit frame by default when the initial pitch and roll angles are zero in the [Unit Installation](#) function block.

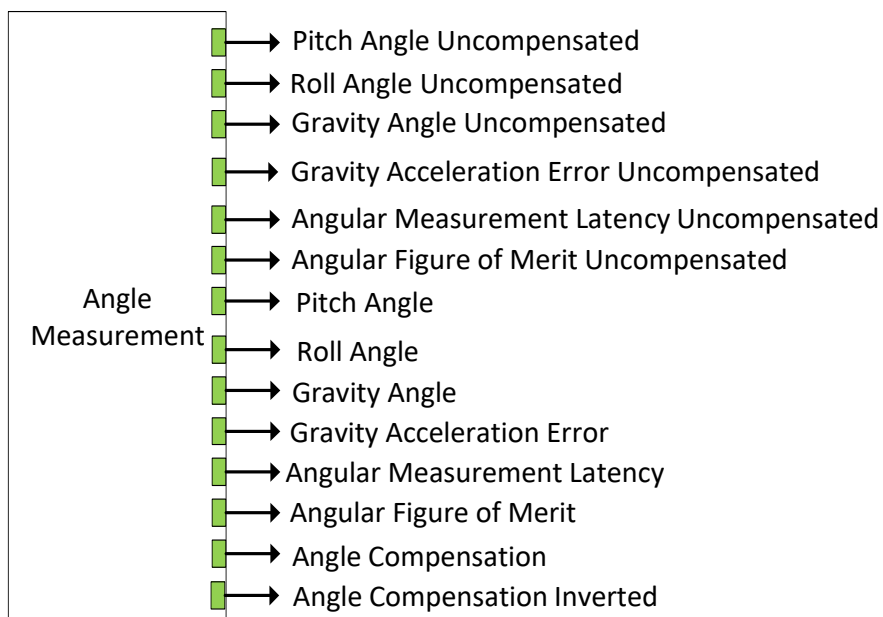

Figure 15. Angle Measurement Function Block

3.4.1 Angle Measurement Signals

The angles can be calculated with or without a sensor fusion algorithm. The angle outputs calculated without the sensor fusion algorithm are named as *Uncompensated*.

For example, *Pitch Angle Uncompensated* output is a version of a regular *Pitch Angle* output calculated without using the sensor fusion algorithm. This allows to evaluate the performance of a sensor fusion algorithm in real time to make a knowledgeable decision whether using the gyroscope-compensated inclinometer provides a noticeable advantage in the customer's application.

The sensor fusion algorithm can be enabled or disabled by the *Dynamic Angle Compensation* configuration parameter. When the sensor fusion is disabled, there is no difference between the uncompensated and regular outputs; they both output the same data.

By default, the *Dynamic Angle Compensation* is *On* and the sensor fusion algorithm is enabled.

The *Pitch Angle* and *Pitch Angle Uncompensated* are continuous signals that output the unit pitch angle θ in [deg]. They have ± 90 [deg] range for Euler angles and ± 180 [deg] for unit rotation angles. For tilt angles, they can be either ± 90 or ± 180 [deg] depending on the *Tilt Angle Range* configuration parameter.

The *Roll Angle* and *Roll Angle Uncompensated* are continuous signals that output the roll angle ϕ in [deg]. They have a full ± 180 [deg] range for Euler and unit rotation angles. For tilt angles, they can be either ± 90 or ± 180 [deg] depending on the *Tilt Angle Range* configuration parameter.

The *Gravity Angle* and *Gravity Angle Uncompensated* are continuous signals that output the gravity angle ρ in [deg]. They have 0...180 [deg] range.

The *Gravity Acceleration Error* and *Gravity Acceleration Error Uncompensated* continuous signals output the gravity acceleration error δ_g in [g].

The *Angular Measurement Latency* and *Angular Measurement Latency Uncompensated* continuous signals output the angular measurement latency in [ms].

The *Angular Figure of Merit* and *Angular Figure of Merit Uncompensated* are discrete signals that define whether the angular output data can be trusted. They have the following set of states:

Table 10. Angular Figure of Merit

| State | Description |
|-------|---|
| 0 | Angular data is fully functional. Data is within the sensor specification. |
| 1 | Angular data is suspect due to environmental conditions. Set when the accelerometer sensor temperature (or the sensor temperature of one of the gyroscopes for sensor fusion) is less than -40°C or greater than $+125^{\circ}\text{C}$. |
| 2 | Error condition has been detected. An error condition can be due to sensor saturation or malfunction or exceeding the maximum gravity acceleration error when the sensor fusion is not active (not used or temporarily disabled). |

The *Angle Compensation* and *Angle Compensation Inverted* are discrete output signals that define whether the sensor fusion algorithm is used. They have the following set of states:

Table 11. Angle Compensation

| State | Description |
|-------|---|
| 0 | Angle Compensation is Off. The sensor fusion algorithm is not used. |
| 1 | Angle Compensation is On. The sensor fusion algorithm is used. |

| State | Description |
|-------|---|
| 2 | Error State. The sensor fusion algorithm is temporarily disabled due to a sensor saturation or error condition. The sensor fusion algorithm must be normally enabled to trigger this error. |

Table 12. Angle Compensation Inverted

| State | Description |
|-------|---|
| 0 | Angle Compensation is On. The sensor fusion algorithm is used. |
| 1 | Angle Compensation is Off. The sensor fusion algorithm is not used. |
| 2 | Error State. The sensor fusion algorithm is temporarily disabled due to a sensor saturation or error condition. The sensor fusion algorithm must be normally enabled to trigger this error. |

The CANopen information about the signals associated with the *Angle Measurement* function block is listed below.

Table 13. Angle Measurement Signals CANopen Information

| Name | Index | Subindex | Data Type | Access | PDO Mapping | Value Range | Default Value |
|---|-------|----------|-----------|--------|-------------|------------------------|---------------|
| Uncompensated Pitch Angle Data | 4220 | 0 | UINT16 | RO | Yes | Depends on Angle Type. | 0 |
| Uncompensated Roll Angle Data | 4230 | 0 | UINT16 | RO | Yes | Depends on Angle Type. | 0 |
| Uncompensated Gravity Angle Data | 4240 | 0 | UINT16 | RO | Yes | Tilt angle range. | 0 |
| Uncompensated Angular Measurement Latency | 4200 | 0 | UINT16 | RO | Yes | UINT16 | 0 |
| Uncompensated Angular Figure of Merit | 4210 | 0 | UINT8 | RO | Yes | {0, 1, 2} | 0 |
| Uncompensated Gravity Acceleration Error | 4250 | 0 | FLOAT32 | RO | Yes | [0...0.5] | 0 |
| Pitch Angle Data Field Value | 4030 | 0 | INT16 | RO | Yes | Depends on Angle Type. | 0 |
| Roll Angle Data Field Value | 4040 | 0 | INT16 | RO | Yes | Depends on Angle Type. | 0 |
| Gravity Angle Data Field Value | 4050 | 0 | INT16 | RO | Yes | Tilt angle range. | 0 |
| Gravity Acceleration Error | 4060 | 0 | FLOAT32 | RO | Yes | [0...0.5] | 0 |
| Angular Measurement Latency | 4130 | 0 | UINT16 | RO | Yes | UINT16 | 0 |
| Angular Figure of Merit | 4140 | 0 | UINT8 | RO | Yes | {0, 1, 2} | 0 |
| Angle Compensation | 4080 | 0 | UINT8 | RO | Yes | {0, 1, 2} | 0 |
| Angle Compensation Inverted | 4090 | 0 | UINT8 | RO | Yes | {0, 1, 2} | 0 |

3.4.2 Angle Measurement Configuration Parameters

This function block also has configuration parameters to control the calculation, and format the *Angle Measurement* data.

The *Data Resolution*, *Data Inversion*, *Data Offset* and parameters configure the output signals for the corresponding Accelerometer Data signal. These parameters affect the signal in the following manner:

$$Output = ((Input \times (-1 \times Inversion)) + Offset) \times \frac{1000}{Resolution}$$

The *Data Range* parameter changes the output angle type. The *Tilt Angle Range* parameter should be left at the default $\pm 180^\circ$ setting to allow for all data range options to be valid.

Table 14. Angle Measurement Data Range

| State | Description |
|-------|--|
| 0 | Semi Rotation. Measures angles in the range of $[-180^\circ \dots 180^\circ]$. |
| 1 | Full Rotation. Measures angles in the range of $[0^\circ \dots 360^\circ]$. |
| 2 | Quarter Rotation. Measures angles in the range of $[0^\circ \dots \pm 90^\circ]$. |

The remaining *Angle Measurement* function block configuration parameters are presented below:

Table 15. Angle Measurement Function Block Configuration Parameters

| Name | Description | Units |
|------------------------------------|---|------------------------------|
| Pitch and Roll Angle Type | Type of the pitch and roll angle. | – |
| Tilt Angle Range | Tilt angle measurement range. | deg |
| Maximum Gravity Acceleration Error | Maximum gravity acceleration error acceptable for the angular calculations. | g |
| Dynamic Angle Compensation | Kalman filter On/Off. Defines whether the inclinometer angles are calculated using the sensor fusion algorithm. Even when the <i>Dynamic Angle Compensation</i> is On, the sensor fusion algorithm can be temporarily disabled due to a gyroscope sensor saturation error or any other sensor malfunction. | – |
| Accelerometer Noise Density | Accelerometer white-noise Kalman filter parameter. | mg/sqrt(Hz) |
| Gyro Noise Density | Gyroscope white-noise Kalman filter parameter. | deg/s/sqrt(Hz) |
| Gyro Rate Random Walk | Gyroscope rate random walk Kalman filter parameter. | deg/s ² /sqrt(Hz) |

The CANopen information about the parameters associated with the *Angle Measurement* function block is listed below.

Table 16. Angle Measurement Configuration Parameters CANopen Information

| Name | Index | Subindex | Data Type | Access | PDO Mapping | Value Range | Default Value |
|--------------------------------|-------|----------|-----------|--------|-------------|---|---------------|
| <i>Angular Data Resolution</i> | 2030 | 0 | UINT8 | RO | No | 3 | 3 |
| Pitch Angle Resolution | | 1 | UINT16 | RW | No | [1...1000] 0.001 degrees/bit | 10 |
| Roll Angle Resolution | | 2 | | | | | |
| Yaw Angle Resolution | | 3 | | | | | |
| <i>Angular Data Inversion</i> | 2031 | 0 | UINT8 | RO | No | 3 | 3 |
| Pitch Angle Inversion | | 1 | UINT8 | RW | No | {0, 1} | 0 |
| Roll Angle Inversion | | 2 | | | | | |
| Yaw Angle Inversion | | 3 | | | | | |
| <i>Angular Data Range</i> | 2032 | 0 | UINT8 | RO | No | 3 | 3 |
| Pitch Angle Range | | 1 | UINT8 | RW | No | 0 – $[-180^\circ \dots 180^\circ]$ 1 – $[0^\circ \dots 360^\circ]$ 2 – $[0^\circ \dots \pm 90^\circ]$ | 0 |
| Roll Angle Range | | 2 | | | | | |
| Yaw Angle Range | | 3 | | | | | |

| | | | | | | | |
|------------------------------------|------|---|---------|----|----|--|--|
| Angular Data Offset | 2040 | 0 | UINT8 | RO | No | 3 | 3 |
| Pitch Angle Offset | | 1 | FLOAT32 | RW | No | FLOAT32 | 0 |
| Roll Angle Offset | | 2 | | | | | |
| Yaw Angle Offset | | 3 | | | | | |
| Pitch and Roll Angle Type | 2100 | 0 | UINT8 | RW | No | 0 – Euler Angle 1 – Tilt Angle 2 – Unit Rotation | 1 ⁽¹⁾ 0 ⁽²⁾ |
| Tilt Angle Range | 2101 | 0 | UINT8 | RW | No | {90°, 180°} | 1 (180°) |
| Maximum Gravity Acceleration Error | 2102 | 0 | FLOAT32 | RW | No | [0...1] | 0.2 |
| Dynamic Angle Compensation | 2103 | 0 | UINT8 | RW | No | [0...1] | 1 |
| Acceleration Noise Density | 2104 | 0 | FLOAT32 | RW | No | [0...1] | 0.12 ⁽³⁾ 0.037 ⁽⁴⁾ |
| Gyro Noise Density | 2105 | 0 | FLOAT32 | RW | No | [0...1] | 0.008 ⁽³⁾ 0.007 ⁽⁴⁾ |
| Gyro Random Walk Rate | 2106 | 0 | FLOAT32 | RW | No | [0...1] | 0.0005 |

⁽¹⁾For AX060900, AX060910. ⁽²⁾For AX062008, AX062018.

⁽³⁾For AX060900, AX062008. ⁽⁴⁾For AX060910, AX062018.

3.5 Unit Installation

The *Unit Installation* function block is used to compensate initial installation angles after the unit is mounted on a machine at a customer's site.



Figure 16. Unit Installation Function Block

The function block has no signal inputs and outputs. Its configuration parameters are presented below.

Table 17. Unit Installation Function Block Configuration Parameters

| Name | Default Value | Range | Units | Description |
|---------------------------------|-----------------|------------------------|-------|--|
| Initial Pitch Angle | 0 | [-90...90] | deg | Initial installation pitch angle. |
| Initial Roll Angle | 0 | [-180...180] | deg | Initial installation roll angle. |
| Installation Mount | 0 | {Horizontal, Vertical} | – | Installation mount orientation. |
| Coordinate Rotation Pitch Angle | 0 | [-180...180] | deg | Initial unit frame rotation pitch angle. |
| Coordinate Rotation Roll Angle | 0 | [-180...180] | deg | Initial unit frame rotation roll angle. |
| Auto-Null Command | No ² | {No, Yes} | – | Auto-Null Command. Set <i>Yes</i> to automatically update the <i>Initial Pitch Angle</i> and <i>Initial Roll Angle</i> . |

²The Auto-Null Command is not a real configuration parameter. It always returns *No* value when being read.

The *Coordinate Rotation Yaw, Pitch and Roll Angles* (ψ, θ, ϕ) are used to change the original orientation of the unit frame. The original orientation is shown on the inclinometer label. The coordinate rotation angles are Euler angles applied in the standard yaw-pitch-roll order to the unit frame.¹

¹In single-axis gyroscope modifications, the unit frame rotation does not change the gyroscope sensing direction and therefore has a limited use.

Alternatively, the unit frame can be adjusted for a unit which is mounted vertically instead of horizontally by setting the *Mounting Installation* parameter to True.

Normally, the coordinate rotation angles are taken in 90-degree increments: 0, ±90, ±180, but theoretically they can be assigned any value in the [-180...+180] degree range.

After the coordinate system is rotated, the user can install the inclinometer on the machine and set the initial installation pitch and roll angles.

The initial installation pitch and roll angles are Euler angles used to transform the unit accelerations from the unit frame to the machine frame. They can be written manually or set up automatically when *Auto-Null Command* is set to Yes.²

²In single-axis gyroscope modifications, the installation pitch angle should be kept small or not used at all. Otherwise the gyroscope X-axis will not be coincident with the machine X-axis, reducing the ability of the single-axis gyroscope to dynamically compensate the roll angle (in the machine frame).

To set up the initial installation angles automatically, the user issues the *Auto-Null Command* when the machine is in the initial null-angle position, leveled on the operation area. The machine frame is coincident with the Earth reference frame in this position, see [Unit Reference Frames](#).

The user should avoid the gimbal lock condition when issuing the *Auto-Null Command* since in this case the *Initial Roll Angle* cannot be accurately defined, and the resulting machine frame orientation can be random, see [Gimbal Lock](#).

The CANopen information about the parameters associated with the *Unit Installation* function block is listed below.

Table 18. Unit Installation Configuration Parameters CANopen Information

| Name | Index | Subindex | Data Type | Access | PDO Mapping | Value Range | Default Value |
|---|-------|----------|-----------|--------|-------------|--------------|---------------|
| Initial Pitch Angle | 2200 | 0 | FLOAT32 | RW | No | [-90°...90°] | 0 |
| Initial Roll Angle | 2210 | 0 | UINT8 | RW | No | [-90°...90°] | 0 |
| Mounting Installation | 2220 | 0 | UINT8 | RW | No | {0, 1} | 0 |
| Initial Coordinate Rotation Yaw Angle | 2230 | 0 | FLOAT32 | RW | No | [-90°...90°] | 0 |
| Initial Coordinate Rotation Pitch Angle | 2240 | 0 | FLOAT32 | RW | No | [-90°...90°] | |
| Initial Coordinate Rotation Roll Angle | 2250 | 0 | FLOAT32 | RW | No | [-90°...90°] | |
| Auto-Null Command | 2300 | 0 | UINT8 | RW | No | {0, 1} | 0 |

3.5.1 Unit Frame Orientation Examples

The user can change the unit frame orientation by applying the *Coordinate Rotation Yaw, Pitch and Roll Angles* (ψ, θ, ϕ) to the original default orientation of the unit frame.

For example, let us assume that the AX060900 unit in the original null-angle position is placed vertically on the machine, long side up, and the angle of interest will be measured as the unit pitch angle, see Figure 17. Remember, that the measured angle cannot be yaw angle, only pitch or roll angle, see [Practical Recommendations](#).

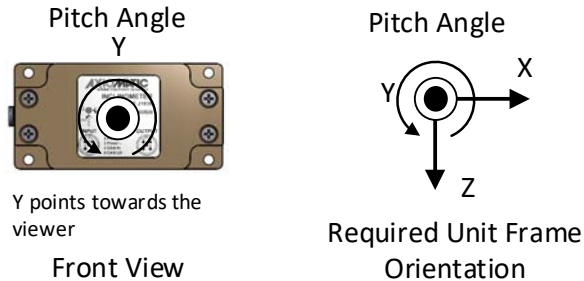

Figure 17. Unit Frame Orientation Example. New Unit Frame Orientation

This assumption will require a new unit frame orientation presented in Figure 17. In the new orientation, the Z-axis points down to be coincident with the gravity vector, the X and Y axes are rotated the way that the Y-axis points towards the viewer, X-axis points right, and rotation about the Y-axis gives the required pitch angle according to the right-hand rule, see [Unit Coordinate System](#).

To convert the original unit frame orientation into the required one, perform $(0,0,-90^\circ)$ coordinate system rotation, see Figure 18.

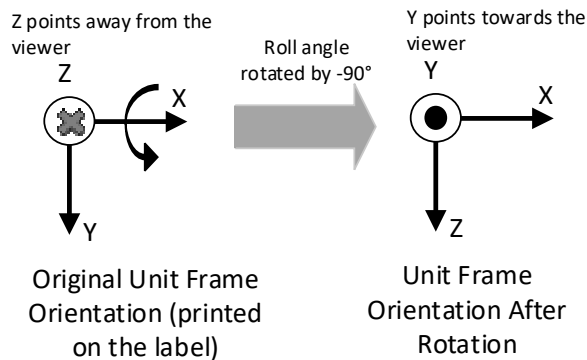

Figure 18. Unit Frame Orientation Example. Coordinate System Rotation

The same way, the unit frame orientation of the horizontal mounting unit AX060900 can be converted into the unit frame orientation of the vertical mounting unit AX062008, using $(90,90,0)$ coordinate system rotation, see Figure 19.

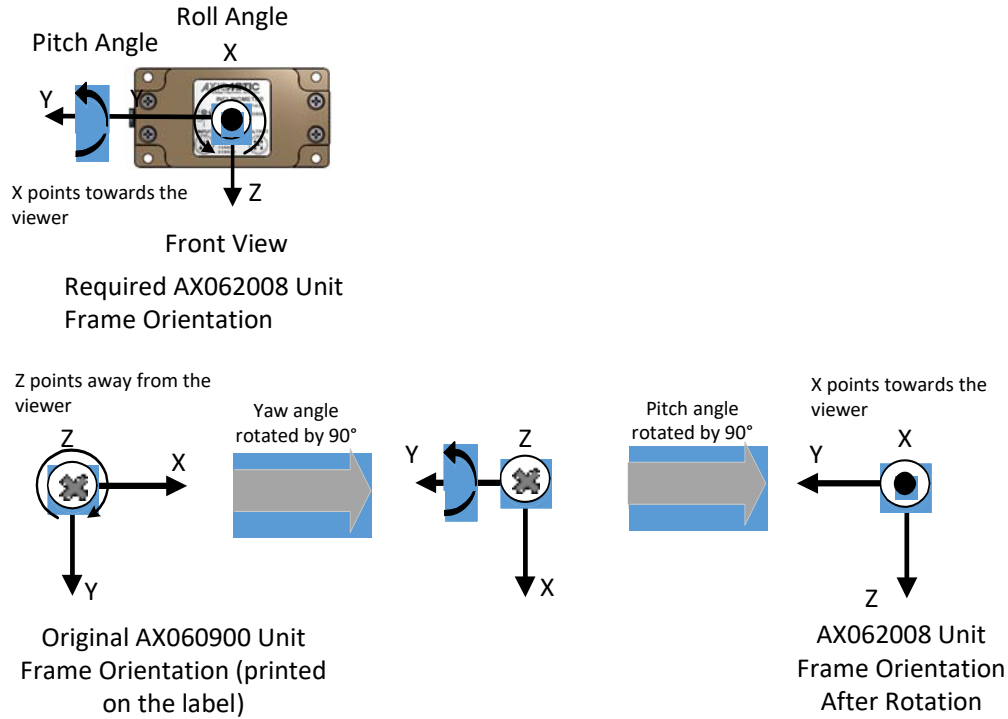

Figure 19. Unit Frame Orientation Example. Conversion AX060900 into AX062008

Since the AX060900 inclinometer has a 3-axis gyro, it can measure not only roll, but also pitch angle in the new vertical mounting position.

In user applications, to avoid errors, it is recommended checking the new unit frame orientation on the bench before installing the inclinometer on the machine. The Axiomatic CAN Assistant – Visual, P/N: AX070501VIS can be used to verify angular directions and ranges after performing the unit frame coordinate rotation.

3.6 Sensor Calibration

The *Sensor Calibration* function block represents internal calibration read-only parameters. It does not have any signal inputs and outputs.

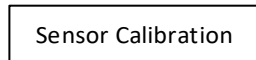

Figure 20. Sensor Calibration

The CANopen information about the parameters associated with the *Sensor Calibration* function block is listed below.

Table 19. Unit Installation Configuration Parameters CANopen Information

| Name | Index | Subindex | Data Type | Access | PDO Mapping | Value Range | Default Value |
|------------------------------------|-------|----------|-----------|--------|-------------|----------------|---------------|
| Calibrated Pitch Angle | 2400 | 0 | FLOAT32 | RO | No | [-90°...90°] | 0 |
| Calibrated Roll Angle | 2410 | 0 | UINT8 | RO | No | [-180°...180°] | 0 |
| Calibrated Gyro Sensor X-Axis Bias | 2420 | 0 | FLOAT32 | RO | No | FLOAT32 | 0 |
| Calibrated Gyro Sensor Y-Axis Bias | 2430 | 0 | FLOAT32 | RO | No | FLOAT32 | 0 |

| | | | | | | | |
|---------------------------------------|------|---|---------|----|----|---------|---|
| Calibrated Gyro Sensor Z-Axis Bias | 2440 | 0 | FLOAT32 | RO | No | FLOAT32 | 0 |
| Calibrated Accel Sensor X-Axis Offset | 2450 | 0 | FLOAT32 | RO | No | FLOAT32 | 0 |
| Calibrated Accel Sensor Y-Axis Offset | 2460 | 0 | FLOAT32 | RO | No | FLOAT32 | 0 |
| Calibrated Accel Sensor Z-Axis Offset | 2470 | 0 | FLOAT32 | RO | No | FLOAT32 | 0 |

3.7 Binary Functions

There are ten *Binary Function* blocks available to the user for performing simple data conversions. Each *Binary Function* block has two continuous signal inputs and one continuous signal output.

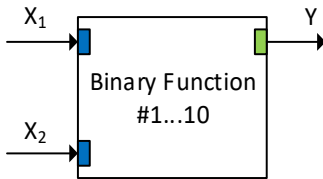

Figure 21. Binary Function Block

The *Binary Function* block performs the following data conversion:

$$Y = A \cdot F[a_1 \cdot f_1(X_1) + b_1; a_2 \cdot f_2(X_2) + b_2] + B, \quad n = 1,2; \quad (11)$$

- where:
- X_n – Input signal;
 - $f_n(X_n)$ – Unary function;
 - a_n – Scale;
 - b_n – Offset;
 - $F[x; y]$ – Binary Function Operation;
 - A – Output Scale;
 - B – Output Offset.

The function block input signals can be undefined. The user can specify a default signal value that will be used when the signal is not defined. If the default signal value is not specified, the output signal of the function block will become undefined too.

The following unary functions can be used to process the input signals:

Table 20. Unary Functions

| Function Name | Description | Comment |
|-----------------|--|--|
| Undefined | $f(x) = x$ | Signal is not processed |
| ! Logical Not | $f(x) = !x$ | x is converted into 4-byte unsigned integer before function is applied |
| ~ Bitwise Not | $f(x) = \sim x$ | x is converted into 4-byte unsigned integer before function is applied |
| abs(x) Absolute | $f(x) = x, \text{ if } x \geq 0$ $f(x) = -x, \text{ if } x < 0$ | |

The following binary function operations are defined in the function block:

Table 21. Binary Function Operations

| # | Function Name | Description | Comment |
|----|------------------|---|--|
| 0 | Undefined | $F[x;y] = \text{Undefined}$ | Output signal is undefined |
| 1 | + Addition | $F[x;y] = x + y$ | |
| 2 | - Subtraction | $F[x;y] = x - y$ | |
| 3 | * Multiplication | $F[x;y] = x * y$ | |
| 4 | / Division | $F[x;y] = x / y$ | Division by 0 gives 0 |
| 5 | % Modulus | $F[x;y] = x \% y$ | x and y are converted into 4-byte unsigned integers before function is applied |
| 6 | max(x,y) Maximum | $F[x;y] = x, \text{ if } x \geq y$ $F[x;y] = y, \text{ if } x < y$ | |
| 7 | min(x,y) Minimum | $F[x;y] = x, \text{ if } x \leq y$ $F[x;y] = y, \text{ if } x > y$ | |
| 8 | == Equal | $F[x;y] = 1, \text{ if } x = y$ $F[x;y] = 0, \text{ if } x \neq y$ | |
| 9 | != Not Equal | $F[x;y] = 1, \text{ if } x \neq y$ $F[x;y] = 0, \text{ if } x = y$ | |
| 10 | > Great | $F[x;y] = 1, \text{ if } x > y$ $F[x;y] = 0, \text{ if } x \leq y$ | |
| 11 | >= Great Equal | $F[x;y] = 1, \text{ if } x \geq y$ $F[x;y] = 0, \text{ if } x < y$ | |
| 12 | < Less | $F[x;y] = 1, \text{ if } x < y$ $F[x;y] = 0, \text{ if } x \geq y$ | |
| 13 | <= Less Equal | $F[x;y] = 1, \text{ if } x \leq y$ $F[x;y] = 0, \text{ if } x > y$ | |
| 14 | Logical OR | $F[x;y] = x \vee y$ | x and y are converted into 4-byte unsigned integers before function is applied |
| 15 | && Logical AND | $F[x;y] = x \wedge y$ | x and y are converted into 4-byte unsigned integers before function is applied |
| 16 | Bitwise OR | $F[x;y] = x y$ | x and y are converted into 4-byte unsigned integers before function is applied |
| 17 | & Bitwise AND | $F[x;y] = x \& y$ | x and y are converted into 4-byte unsigned integers before function is applied |
| 18 | ^ Bitwise XOR | $F[x;y] = x \wedge y$ | x and y are converted into 4-byte unsigned integers before function is applied |
| 19 | << Left Shift | $F[x;y] = x \ll y$ | x and y are converted into 4-byte unsigned integers before function is applied |
| 20 | >> Right Shift | $F[x;y] = x \gg y$ | x and y are converted into 4-byte unsigned integers before function is applied |

The CANopen information about the parameters associated with the group of *Binary Function* blocks is listed below.

Table 22. Binary Function Parameters CANopen Information

| Name | Index | Subindex | Data Type | Access | PDO Mapping | Value Range | Default Value |
|---|-------|----------|-----------|--------|-------------|-------------|---------------|
| <i>Binary Function Output Field Value</i> | 3000 | 0 | UINT8 | RO | No | 10 | 10 |
| Binary Function 1 Output FV | | 1 | INT16 | RO | Yes | | 0 |
| Binary Function 2 Output FV | | 2 | | | | | |
| Binary Function 3 Output FV | | 3 | | | | | |
| Binary Function 4 Output FV | | 4 | | | | | |

| | | | | | | | |
|--|------|----|---------|----|----|----------|----|
| Binary Function 5 Output FV | | 5 | | | | | |
| Binary Function 6 Output FV | | 6 | | | | | |
| Binary Function 7 Output FV | | 7 | | | | | |
| Binary Function 8 Output FV | | 8 | | | | | |
| Binary Function 9 Output FV | | 9 | | | | | |
| Binary Function 10 Output FV | | 10 | | | | | |
| <i>Binary Function Operation</i> | | 0 | UINT8 | RO | No | 10 | 10 |
| Binary Function 1 Operation | 300A | 1 | UINT8 | RW | No | [0...20] | 0 |
| Binary Function 2 Operation | | 2 | | | | | |
| Binary Function 3 Operation | | 3 | | | | | |
| Binary Function 4 Operation | | 4 | | | | | |
| Binary Function 5 Operation | | 5 | | | | | |
| Binary Function 6 Operation | | 6 | | | | | |
| Binary Function 7 Operation | | 7 | | | | | |
| Binary Function 8 Operation | | 8 | | | | | |
| Binary Function 9 Operation | | 9 | | | | | |
| Binary Function 10 Operation | | 10 | | | | | |
| <i>Binary Function Output Scaling</i> | | 0 | UINT8 | RO | No | 10 | 10 |
| Binary Function 1 Output Scaling | 300B | 1 | FLOAT32 | RW | No | FLOAT32 | 1 |
| Binary Function 2 Output Scaling | | 2 | | | | | |
| Binary Function 3 Output Scaling | | 3 | | | | | |
| Binary Function 4 Output Scaling | | 4 | | | | | |
| Binary Function 5 Output Scaling | | 5 | | | | | |
| Binary Function 6 Output Scaling | | 6 | | | | | |
| Binary Function 7 Output Scaling | | 7 | | | | | |
| Binary Function 8 Output Scaling | | 8 | | | | | |
| Binary Function 9 Output Scaling | | 9 | | | | | |
| Binary Function 10 Output Scaling | | 10 | | | | | |
| <i>Binary Function Output Offset</i> | | 0 | UINT8 | RO | No | 10 | 10 |
| Binary Function 1 Output Offset | 300C | 1 | FLOAT32 | RW | No | FLOAT32 | 0 |
| Binary Function 2 Output Offset | | 2 | | | | | |
| Binary Function 3 Output Offset | | 3 | | | | | |
| Binary Function 4 Output Offset | | 4 | | | | | |
| Binary Function 5 Output Offset | | 5 | | | | | |
| Binary Function 6 Output Offset | | 6 | | | | | |
| Binary Function 7 Output Offset | | 7 | | | | | |
| Binary Function 8 Output Offset | | 8 | | | | | |
| Binary Function 9 Output Offset | | 9 | | | | | |
| Binary Function 10 Output Offset | | 10 | | | | | |
| <i>Binary Function x Signal 1 & 2 Source</i> | 30x0 | 0 | UINT8 | RO | No | 2 | 2 |
| Binary Function x Signal 1 Source | | 1 | UINT8 | RW | No | [0...48] | 0 |
| Binary Function x Signal 2 Source | | 2 | | | | | |
| <i>Binary Function x Signal 1 & 2 Is Default</i> | 30x1 | 0 | UINT8 | RO | No | 2 | 2 |
| Binary Function x Signal 1 Is Default | | 1 | UINT8 | RW | No | {0, 1} | 0 |
| Binary Function x Signal 2 Is Default | | 2 | | | | | |
| <i>Binary Function x Signal 1 & 2 Default Value</i> | 30x2 | 0 | UINT8 | RO | No | 2 | 2 |
| Binary Function x Signal 1 Default Value | | 1 | FLOAT32 | RW | No | FLOAT32 | 0 |
| Binary Function x Signal 2 Default Value | | 2 | | | | | |
| <i>Binary Function x Signal 1 & 2 Unary Function</i> | 30x3 | 0 | UINT8 | RO | No | 2 | 2 |
| Binary Function x Signal 1 Unary Function | | 1 | UINT8 | RW | No | {0...3} | 0 |
| Binary Function x Signal 2 Unary Function | | 2 | | | | | |
| <i>Binary Function x Signal 1 & 2 Scaling</i> | 30x4 | 0 | UINT8 | RO | No | 2 | 2 |

| | | | | | | | |
|--|------|---|---------|----|----|---------|---|
| Binary Function x Signal 1 Scaling | | 1 | FLOAT32 | RW | No | FLOAT32 | 0 |
| Binary Function x Signal 2 Scaling | | 2 | FLOAT32 | RW | No | FLOAT32 | 0 |
| <i>Binary Function x Signal 1 & 2 Offset</i> | 30x5 | 0 | UINT8 | RO | No | 2 | 2 |
| Binary Function x Signal 1 Offset | | 1 | FLOAT32 | RW | No | FLOAT32 | 0 |
| Binary Function x Signal 2 Offset | | 2 | FLOAT32 | RW | No | FLOAT32 | 0 |

3.8 Global Parameters

The *Global Parameters* functional block gives the user access to a set of global constants, unit supply voltage and the microcontroller internal temperature.

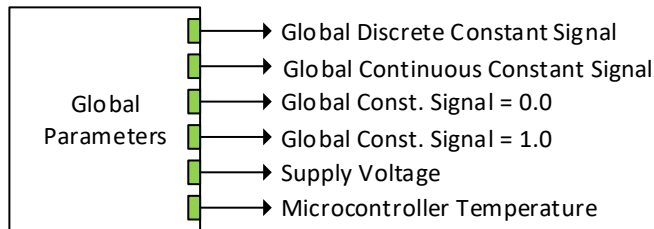

Figure 22. *Global Parameters Function Block*

The function block has one configurable *Global Discrete Constant Signal* output, one configurable *Global Continuous Constant Signal* output and two continuous pre-set constant signal outputs: *Global Const. Signal = 0.0* and *Global Const. Signal = 1.0*.

The function block also contains *Supply Voltage* continuous signal output presenting the inclinometer supply voltage in [V]. Please note, that this voltage is not the voltage on the inclinometer power supply connector pins. It is an internal voltage measured after the EMI filter, reverse polarity, and transient protection circuit. It is always less than the actual power supply voltage by approximately 0.7...0.95 V.

The microcontroller internal temperature is presented on the *Microcontroller Temperature* continuous signal output in [°C].

The CANopen information about the parameters associated with the *Global Parameters* function block is listed below.

Table 23. *Global Parameters CANopen Information*

| Name | Index | Subindex | Data Type | Access | PDO Mapping | Value Range | Default Value |
|-----------------------------------|-------|----------|-----------|--------|-------------|-------------|---------------|
| Global Discrete Constant Signal | 4270 | 0 | UINT32 | RW | Yes | UINT32 | 0 |
| Global Continuous Constant Signal | 4260 | 0 | FLOAT32 | RW | Yes | FLOAT32 | 0 |
| Power Supply Field Value | 5000 | 0 | FLOAT32 | RO | Yes | 0-70 | 0 |
| Processor Temperature Field Value | 5010 | 0 | FLOAT32 | RO | Yes | | 0 |

3.9 RPDO Messages

The *RPDO Objects* functional block allows for data received to be mapped as a control source for other function blocks.



Figure 23. *RPDO Objects Function Block*

The *RPDO Data Received PV*, *RPDO Data Received Resolution PV*, and *RPDO Data Received Offset PV* objects are used to map CANopen RPDO messages to various function blocks as a control source. For example, a Binary Function is used to compare the Pitch Angle to a target/limit angle from another source from the CAN bus.

Table 24. *RPDO Messages CANopen Information*

| Name | Index | Subindex | Data Type | Access | PDO Mapping | Value Range | Default Value |
|---|-------|----------|-----------|--------|-------------|-------------|---------------|
| <i>RPDO Data Received PV</i> | 2500 | 0 | UINT8 | RO | No | 3 | 3 |
| Pitch Angle Resolution | | 1 | UINT16 | RW | Yes | | 0 |
| Roll Angle Resolution | | 2 | | | | | |
| Yaw Angle Resolution | | 3 | | | | | |
| <i>RPDO Data Received Resolution PV</i> | 2501 | 0 | UINT8 | RO | No | 3 | 3 |
| Pitch Angle Inversion | | 1 | UINT16 | RW | No | [1...1000] | 1000 |
| Roll Angle Inversion | | 2 | | | | | |
| Yaw Angle Inversion | | 3 | | | | | |
| <i>RPDO Data Received Offset PV</i> | 2502 | 0 | UINT8 | RO | No | 3 | 3 |
| Pitch Angle Range | | 1 | REAL32 | RW | No | REAL32 | 0 |
| Roll Angle Range | | 2 | | | | | |
| Yaw Angle Range | | 3 | | | | | |

3.10 Miscellaneous Parameters

The *Miscellaneous Parameters* functional block allows the user to control certain settings which affect how the unit will operate.

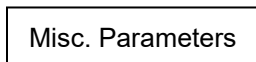

Figure 24. *Miscellaneous Parameters*

The *CAN Slew Rate* parameter sets the slew rate control of the CAN transceiver to either Low (0), or High (1).

The *Start in Operational Mode* parameter changes the NMT starting state of the unit, the set of states are as follows:

Table 25. *Start in Operational Mode*

| State | Description |
|-------|-------------------------------|
| 0 | No action, wait NMT commands. |

| State | Description |
|-------|--|
| 1 | Start directly in operational mode. |
| 2 | Start in operational mode and send NMT for starting other devices. |
| 3 | Start in operational mode and set PDS FSA to Enabled Mode. |

By setting the *Start Bootloader* parameter to True (1), the firmware can be bypassed, and the controller will restart running the bootloader. This can be used to reflash the firmware, see the [Flashing New Firmware](#) section for further details.

The baud rate and node ID used in CANopen communications can be changed through the *Change Baud Rate* and *Change Node ID* parameters. The set of states for changing the baud rate are as follows:

Table 26. *Change Baud Rate*

| State | Description |
|-------|-------------------------------|
| 0 | 1000 kbps baud rate. |
| 1 | 800 kbps baud rate. |
| 2 | 500 kbps baud rate. |
| 3 | 250 kbps baud rate. |
| 4 | 125 kbps baud rate. |
| 5 | RESERVED; Cannot be selected. |
| 6 | 50 kbps baud rate. |
| 7 | 20 kbps baud rate. |
| 8 | 10 kbps baud rate. |

The CANopen information about the parameters associated with the *Miscellaneous Parameters* function block is listed below.

Table 27. *Miscellaneous Parameters CANopen Information*

| Name | Index | Subindex | Data Type | Access | PDO Mapping | Value Range | Default Value |
|---------------------------|-------|----------|-----------|--------|-------------|----------------|---------------|
| CAN Slew Rate | 2000 | 0 | UINT8 | RW | No | {0, 1} | 0 |
| Start in Operational Mode | 5555 | 0 | UINT8 | RW | No | {0...3} | 0 |
| Start Bootloader | 55AA | 0 | UINT8 | RW | No | {0, 1} | 0 |
| Change Baud Rate | 5B50 | 0 | UINT8 | RWP | No | {0...4, 6...8} | 4 |
| Change Node ID | 5B51 | 0 | UINT8 | RWP | No | {0... 0x7F} | 127 |

4 CANOPEN® OBJECT DICTIONARY

The CANopen object dictionary of the inclinometer is based on Manufacturer-Specific objects for functionalities relating to Axiomatic's Tri-Axial Gyro Inclinometer. The object dictionary includes Communication Objects beyond the minimum requirements in the profile, as well as several manufacturer-specific objects for extended functionality.

4.1 NODE ID and BAUDRATE

By default, the Triaxial Gyro Inclinometer Controller ships factory programmed with a Node ID = 127 (0x7F) and with Baudrate = 125 kbps.

4.2 COMMUNICATION OBJECTS (DS-301)

The communication objects supported by the Tri-Axial Gyro Inclinometer are listed in the following table. A more detailed description of some of the objects is given in the following subchapters. Only those objects that have device-profile specific information are described. For more information on the other objects, refer to the generic CANopen protocol specification DS-301.

| <i>Index (hex)</i> | <i>Object</i> | <i>Object Type</i> | <i>Data Type</i> | <i>Access</i> | <i>PDO Mapping</i> |
|--------------------|-------------------------------|--------------------|------------------|---------------|--------------------|
| 1000 | Device Type | VAR | UNSIGNED32 | RO | No |
| 1001 | Error Register | VAR | UNSIGNED8 | RO | No |
| 1002 | Manufacturer Status Register | VAR | UNSIGNED32 | RO | No |
| 1003 | Pre-Defined Error Field | ARRAY | UNSIGNED32 | RO | No |
| 100C | Guard Time | VAR | UNSIGNED16 | RW | No |
| 100D | Life Time Factor | VAR | UNSIGNED8 | RW | No |
| 1010 | Store Parameters | ARRAY | UNSIGNED32 | RW | No |
| 1011 | Restore Default Parameters | ARRAY | UNSIGNED32 | RW | No |
| 1016 | Consumer Heartbeat Time | ARRAY | UNSIGNED32 | RW | No |
| 1017 | Producer Heartbeat Time | VAR | UNSIGNED16 | RW | No |
| 1018 | Identity Object | RECORD | | RO | No |
| 1020 | Verify Configuration | ARRAY | UNSIGNED32 | RO | No |
| 1029 | Error Behaviour | ARRAY | UNSIGNED8 | RW | No |
| 1400 | RPDO1 Communication Parameter | RECORD | | RW | No |
| 1401 | RPDO2 Communication Parameter | RECORD | | RW | No |
| 1402 | RPDO3 Communication Parameter | RECORD | | RW | No |
| 1403 | RPDO4 Communication Parameter | RECORD | | RW | No |
| 1600 | RPDO1 Mapping Parameter | RECORD | | RO | No |
| 1601 | RPDO2 Mapping Parameter | RECORD | | RO | No |
| 1602 | RPDO3 Mapping Parameter | RECORD | | RO | No |
| 1603 | RPDO4 Mapping Parameter | RECORD | | RO | No |
| 1800 | TPDO1 Communication Parameter | RECORD | | RW | No |

| | | | | | |
|------|-------------------------------|--------|--|----|----|
| 1801 | TPDO2 Communication Parameter | RECORD | | RW | No |
| 1802 | TPDO3 Communication Parameter | RECORD | | RW | No |
| 1803 | TPDO4 Communication Parameter | RECORD | | RW | No |
| 1A00 | TPDO1 Mapping Parameter | RECORD | | RW | No |
| 1A01 | TPDO2 Mapping Parameter | RECORD | | RW | No |
| 1A02 | TPDO3 Mapping Parameter | RECORD | | RW | No |
| 1A03 | TPDO4 Mapping Parameter | RECORD | | RW | No |

Table 28. Object 1000h: Device Type

| Index | Subindex | Data Type | Access | PDO Mapping | Value Range | Default Value | Description |
|-------|----------|-----------|--------|-------------|-------------|---------------|-------------|
| 1000 | 0 | UINT32 | RO | No | | 0x0 | |

Table 29. Object 1001h: Error Register

| Index | Subindex | Data Type | Access | PDO Mapping | Value Range | Default Value | Description |
|-------|----------|-----------|--------|-------------|-------------|---------------|-----------------|
| 1001 | 0 | UINT8 | RO | No | 0, 1 | 0 | Error register. |

Table 30. Object 1002h: Manufacturer Status Register

| Index | Subindex | Data Type | Access | PDO Mapping | Value Range | Default Value | Description |
|-------|----------|-----------|--------|-------------|-------------|---------------|---------------------------------|
| 1002 | 0 | UINT32 | RO | No | UINT32 | 0 | Manufacturer debug information. |

Table 31. Object 1003h: Pre-Defined Error Field

| Index | Subindex | Data Type | Access | PDO Mapping | Value Range | Default Value | Description |
|-------|----------|-----------|--------|-------------|-------------|---------------|--|
| 1003 | 0 | UINT8 | RO | No | UINT32 | 4 | Number of subindexes / reset error codes |
| | 1 | UINT32 | | | | 0 | EMCY error code #1 |
| | 2 | | | | | | EMCY error code #2 |
| | 3 | | | | | | EMCY error code #3 |
| | 4 | | | | | | EMCY error code #4 |

Table 32. Object 100Ch: Guard Time

| Index | Subindex | Data Type | Access | PDO Mapping | Value Range | Default Value | Description |
|-------|----------|-----------|--------|-------------|-------------|---------------|---|
| 100C | 0 | UINT16 | RW | No | UINT32 | 0 | Guard time in milliseconds. Only supported for backwards compatibility, newer networks should use heartbeat monitoring (these cannot be used simultaneously). |

Table 33. Object 100Dh: Life Time Factor

| Index | Subindex | Data Type | Access | PDO Mapping | Value Range | Default Value | Description |
|-------|----------|-----------|--------|-------------|-------------|---------------|--|
| 100D | 0 | UINT8 | RW | No | 0-255 | 0 | This factor multiplied by the guard time gives the life time of the life guarding protocol. A value of 0 disables life guarding. |

Table 34. Object 1010h: Store Parameters

| Index | Subindex | Data Type | Access | PDO Mapping | Value Range | Default Value | Description |
|-------|----------|-----------|--------|-------------|-------------|---------------|----------------------|
| 1010 | 0 | UINT8 | RO | No | | 4 | Number of subindexes |

| | | | | | | | |
|--|---|--------|----|--|------|---|--|
| | 1 | UINT32 | RW | | save | 1 | Write 0x65766173 ('e', 'v', 'a', 's') for storing ALL parameters |
| | 2 | | | | | | Write 0x65766173 ('e', 'v', 'a', 's') for storing Communication parameters |
| | 3 | | | | | | Write 0x65766173 ('e', 'v', 'a', 's') for storing Application parameters |
| | 4 | | | | | | Write 0x65766173 ('e', 'v', 'a', 's') for storing Manufacturer parameters |

Table 35. Object 1011h: Restore Parameters

| Index | Subindex | Data Type | Access | PDO Mapping | Value Range | Default Value | Description |
|-------|----------|-----------|--------|-------------|--|---------------|--|
| 1011 | 0 | UINT8 | RO | No | | 4 | Number of subindexes |
| | 1 | UINT32 | RW | | load | 1 | Write 0x64616F6C ('d', 'a', 'o', 'l') for restoring ALL parameters |
| | 2 | | | | Write 0x64616F6C ('d', 'a', 'o', 'l') for restoring Communication parameters | | |
| | 3 | | | | Write 0x64616F6C ('d', 'a', 'o', 'l') for restoring Application parameters | | |
| | 4 | | | | Write 0x64616F6C ('d', 'a', 'o', 'l') for restoring Manufacturer parameters | | |
| | | | | | | | |

Table 36. Object 1016h: Consumer Heartbeat Time

| Index | Subindex | Data Type | Access | PDO Mapping | Value Range | Default Value | Description |
|-------|----------|-----------|--------|-------------|---|---------------|-------------------------|
| 1016 | 0 | UINT8 | RO | No | | 4 | Number of subindexes |
| | 1 | UINT32 | RW | | UINT32 | 0 | Consumer heartbeat time |
| | 2 | | | | bits 31-24: reserved | | |
| | 3 | | | | bits 23-16: Node ID | | |
| | 4 | | | | bits 15-0: heartbeat time in milliseconds | | |
| | | | | | | | |

Table 37. Object 1017h: Producer Heartbeat Time

| Index | Subindex | Data Type | Access | PDO Mapping | Value Range | Default Value | Description |
|-------|----------|-----------|--------|-------------|-------------|---------------|---|
| 1017 | 0 | UINT16 | RW | No | 10-65000 | 0 | Producer heartbeat time in milliseconds |

Table 38. Object 1018h: Identity Object

| Index | Subindex | Data Type | Access | PDO Mapping | Value Range | Default Value | Description |
|-------|----------|-----------|--------|-------------|-------------|-----------------|------------------------------------|
| 1018 | 0 | UINT8 | RO | No | | 4 | Number of subindexes |
| | 1 | UINT32 | | | UINT32 | 0x55 | Vendor ID (Axiomatic Technologies) |
| | 2 | | | | 0xAA060911 | Product Code | |
| | 3 | | | | 0 | Revision Number | |
| | 4 | | | | 0 | Serial Number | |
| | | | | | | | |

Table 39. Object 1020h: Verify Configuration

| Index | Subindex | Data Type | Access | PDO Mapping | Value Range | Default Value | Description |
|-------|----------|-----------|--------|-------------|---------------------------|--------------------------------|----------------------|
| 1020 | 0 | UINT8 | RO | No | | 2 | Number of subindexes |
| | 1 | UINT32 | | | UINT32 | Configuration date: DD-MM-YYYY | |
| | 2 | | | | Configuration time: HH-MM | | |

Table 40. Object 1029h: Error Behaviour

| Index | Subindex | Data Type | Access | PDO Mapping | Value Range | Default Value | Description |
|-------|----------|-----------|--------|-------------|-------------|---------------|---------------------------------|
| 1029 | 0 | UINT8 | RO | No | | 2 | Number of subindexes |
| | 1 | | RW | | 0-2 | 1 (no change) | State transition on Comm. fault |
| | 2 | | | | | | State transition on DI fault |

Table 41. Object 1400h: RPDO 1 Communication Parameters

| Index | Subindex | Data Type | Access | PDO Mapping | Value Range | Default Value | Description |
|-------|----------|-----------|--------|-------------|-------------|---------------|----------------------|
| 1400 | 0 | UINT8 | RO | No | | 5 | Number of subindexes |
| | 1 | UINT32 | RW | | UINT32 | 0xC000027F | COB-ID |
| | 2 | UINT8 | | | UINT8 | 0xFF | Transmission type |
| | 3 | UINT16 | | | UINT16 | 0 | Inhibit time |
| | 4 | UINT8 | | | UINT8 | 0 | Compatibility entry |
| | 5 | UINT16 | | | UINT16 | 0 | Event timer |

Table 42. Object 1401h: RPDO 2 Communication Parameters

| Index | Subindex | Data Type | Access | PDO Mapping | Value Range | Default Value | Description |
|-------|----------|-----------|--------|-------------|-------------|---------------|----------------------|
| 1401 | 0 | UINT8 | RO | No | | 5 | Number of subindexes |
| | 1 | UINT32 | RW | | UINT32 | 0xC000037F | COB-ID |
| | 2 | UINT8 | | | UINT8 | 0xFF | Transmission type |
| | 3 | UINT16 | | | UINT16 | 0 | Inhibit time |
| | 4 | UINT8 | | | UINT8 | 0 | Compatibility entry |
| | 5 | UINT16 | | | UINT16 | 0 | Event timer |

Table 43. Object 1402h: RPDO 3 Communication Parameters

| Index | Subindex | Data Type | Access | PDO Mapping | Value Range | Default Value | Description |
|-------|----------|-----------|--------|-------------|-------------|---------------|----------------------|
| 1402 | 0 | UINT8 | RO | No | | 5 | Number of subindexes |
| | 1 | UINT32 | RW | | UINT32 | 0xC000047F | COB-ID |
| | 2 | UINT8 | | | UINT8 | 0xFF | Transmission type |
| | 3 | UINT16 | | | UINT16 | 0 | Inhibit time |
| | 4 | UINT8 | | | UINT8 | 0 | Compatibility entry |
| | 5 | UINT16 | | | UINT16 | 0 | Event timer |

Table 44. Object 1403h: RPDO 4 Communication Parameters

| Index | Subindex | Data Type | Access | PDO Mapping | Value Range | Default Value | Description |
|-------|----------|-----------|--------|-------------|-------------|---------------|----------------------|
| 1403 | 0 | UINT8 | RO | No | | 5 | Number of subindexes |
| | 1 | UINT32 | RW | | UINT32 | 0xC000057F | COB-ID |
| | 2 | UINT8 | | | UINT8 | 0xFF | Transmission type |
| | 3 | UINT16 | | | UINT16 | 0 | Inhibit time |
| | 4 | UINT8 | | | UINT8 | 0 | Compatibility entry |
| | 5 | UINT16 | | | UINT16 | 0 | Event timer |

Table 45. Object 1600h: RPDO 1 Mapping Parameters

| Index | Subindex | Data Type | Access | PDO Mapping | Value Range | Default Value | Description |
|-------|----------|-----------|--------|-------------|-------------|---------------|------------------------------|
| 1600 | 0 | UINT8 | RO | No | | 3 | Number of subindexes |
| | 1 | UINT32 | | | UINT32 | 0x25000110 | EC Extra Received PV Value 1 |
| | 2 | | | | | 0x25000210 | EC Extra Received PV Value 2 |
| | 3 | | | | | 0x25000310 | EC Extra Received PV Value 3 |
| | 4 | | | | | 0 | Not used by default |

Table 46. Object 1601h: RPDO 2 Mapping Parameters

| Index | Subindex | Data Type | Access | PDO Mapping | Value Range | Default Value | Description |
|-------|----------|-----------|--------|-------------|-------------|---------------|----------------------|
| 1601 | 0 | UINT8 | RO | No | | 0 | Number of subindexes |
| | 1 | UINT32 | | | UINT32 | 0 | Not used by default |
| | 2 | | | | | 0 | Not used by default |
| | 3 | | | | | 0 | Not used by default |
| | 4 | | | | | 0 | Not used by default |

Table 47. Object 1602h: RPDO 3 Mapping Parameters

| Index | Subindex | Data Type | Access | PDO Mapping | Value Range | Default Value | Description |
|-------|----------|-----------|--------|-------------|-------------|---------------|----------------------|
| 1602 | 0 | UINT8 | RO | No | UINT32 | 0 | Number of subindexes |
| | 1 | UINT32 | | | | 0 | Not used by default |
| | 2 | | | | | 0 | Not used by default |
| | 3 | | | | | 0 | Not used by default |
| | 4 | | | | | 0 | Not used by default |

Table 48. Object 1603h: RPDO 4 Mapping Parameters

| Index | Subindex | Data Type | Access | PDO Mapping | Value Range | Default Value | Description |
|-------|----------|-----------|--------|-------------|-------------|---------------|----------------------|
| 1603 | 0 | UINT8 | RO | No | UINT32 | 0 | Number of subindexes |
| | 1 | UINT32 | | | | 0 | Not used by default |
| | 2 | | | | | 0 | Not used by default |
| | 3 | | | | | 0 | Not used by default |
| | 4 | | | | | 0 | Not used by default |

Table 49. Object 1800h: TPDO 1 Communication Parameters

| Index | Subindex | Data Type | Access | PDO Mapping | Value Range | Default Value | Description |
|-------|----------|-----------|--------|-------------|-------------|---------------|----------------------|
| 1800 | 0 | UINT8 | RO | No | | 5 | Number of subindexes |
| | 1 | UINT32 | RW | | UINT32 | 0x400001FF | COB-ID |
| | 2 | UINT8 | RO | | UINT8 | 0xFE | Transmission type |
| | 3 | UINT16 | RW | | UINT16 | 0 | Inhibit time |
| | 4 | UINT8 | | | UINT8 | 0 | Compatibility entry |
| | 5 | UINT16 | | | UINT16 | 0xFA | Event timer |

Table 50. Object 1801h: TPDO 2 Communication Parameters

| Index | Subindex | Data Type | Access | PDO Mapping | Value Range | Default Value | Description |
|-------|----------|-----------|--------|-------------|-------------|---------------|----------------------|
| 1801 | 0 | UINT8 | RO | No | | 5 | Number of subindexes |
| | 1 | UINT32 | RW | | UINT32 | 0x400002FF | COB-ID |
| | 2 | UINT8 | RO | | UINT8 | 0xFE | Transmission type |
| | 3 | UINT16 | RW | | UINT16 | 0 | Inhibit time |
| | 4 | UINT8 | | | UINT8 | 0 | Compatibility entry |
| | 5 | UINT16 | | | UINT16 | 0 | Event timer |

Table 51. Object 1802h: TPDO 3 Communication Parameters

| Index | Subindex | Data Type | Access | PDO Mapping | Value Range | Default Value | Description |
|-------|----------|-----------|--------|-------------|-------------|---------------|----------------------|
| 1802 | 0 | UINT8 | RO | No | | 5 | Number of subindexes |
| | 1 | UINT32 | RW | | UINT32 | 0xC00003FF | COB-ID |
| | 2 | UINT8 | RO | | UINT8 | 0xFE | Transmission type |
| | 3 | UINT16 | RW | | UINT16 | 0 | Inhibit time |
| | 4 | UINT8 | | | UINT8 | 0 | Compatibility entry |
| | 5 | UINT16 | | | UINT16 | 0 | Event timer |

Table 52. Object 1803h: TPDO 4 Communication Parameters

| Index | Subindex | Data Type | Access | PDO Mapping | Value Range | Default Value | Description |
|-------|----------|-----------|--------|-------------|-------------|---------------|----------------------|
| 1803 | 0 | UINT8 | RO | No | | 5 | Number of subindexes |
| | 1 | UINT32 | RW | | UINT32 | 0xC00004FF | COB-ID |
| | 2 | UINT8 | RO | | UINT8 | 0xFE | Transmission type |
| | 3 | UINT16 | RW | | UINT16 | 0 | Inhibit time |
| | 4 | UINT8 | | | UINT8 | 0 | Compatibility entry |
| | 5 | UINT16 | | | UINT16 | 0 | Event timer |

Table 53. Object 1A00h: TPDO 1 Mapping Parameters

| Index | Subindex | Data Type | Access | PDO Mapping | Value Range | Default Value | Description |
|-------|----------|-----------|--------|-------------|-------------|---------------|--------------------------------------|
| 1A00 | 0 | UINT8 | RW | No | UINT32 | 2 | Number of subindexes |
| | 1 | UINT32 | | | | 0x40300010 | Pitch Angle |
| | 2 | | | | | 0x40400010 | Roll Angle |
| | 3 | | | | | 0x51510008 | Application-specific message counter |
| | 4 | | | | | 0 | Not used by default |

Table 54. Object 1A01h: TPDO 2 Mapping Parameters

| Index | Subindex | Data Type | Access | PDO Mapping | Value Range | Default Value | Description |
|-------|----------|-----------|--------|-------------|-------------|---------------|----------------------------------|
| 1A01 | 0 | UINT8 | RW | No | UINT32 | 3 | Number of subindexes |
| | 1 | UINT32 | | | | 0x40000110 | Accelerometer Data X-Axis |
| | 2 | | | | | 0x40000210 | Accelerometer Data Y-Axis |
| | 3 | | | | | 0x40000310 | Accelerometer Data Z-Axis |
| | 4 | | | | | 0x40600010 | Accelerometer Sensor Temperature |

Table 55. Object 1A02h: TPDO 3 Mapping Parameters

| Index | Subindex | Data Type | Access | PDO Mapping | Value Range | Default Value | Description |
|-------|----------|-----------|--------|-------------|-------------|---------------|-----------------------|
| 1A02 | 0 | UINT8 | RW | No | UINT32 | 2 | Number of subindexes |
| | 1 | UINT32 | | | | 0x50000020 | Power Supply 32 |
| | 2 | | | | | 0x50100020 | Sensor Temperature 32 |
| | 3 | | | | | 0 | Not used by default |
| | 4 | | | | | 0 | Not used by default |

Table 56. Object 1A03h: TPDO 4 Mapping Parameters

| Index | Subindex | Data Type | Access | PDO Mapping | Value Range | Default Value | Description |
|-------|----------|-----------|--------|-------------|-------------|---------------|----------------------|
| 1A03 | 0 | UINT8 | RW | No | UINT32 | 0 | Number of subindexes |
| | 1 | UINT32 | | | | 0 | Not used by default |
| | 2 | | | | | 0 | Not used by default |
| | 3 | | | | | 0 | Not used by default |
| | 4 | | | | | 0 | Not used by default |

4.3 MANUFACTURER OBJECTS

| Index (hex) | Object | Object Type | Data Type | Access | PDO Mapping |
|-------------|---------------------------------------|-------------|------------|--------|-------------|
| 2000 | CAN Slew Rate | VAR | UNSIGNED8 | RW | No |
| 2002 | Gyro Sensor Input Filter Enabled | VAR | UNSIGNED8 | RW | No |
| 2003 | Gyro Input Filter Cut-Off Frequency | VAR | UNSIGNED8 | RW | No |
| 2004 | Accel Sensor Input Filter Enabled | VAR | UNSIGNED8 | RW | No |
| 2005 | Accel Input Filter Cut-Off Frequency | VAR | UNSIGNED8 | RW | No |
| 2010 | Accelerometer Data Resolution | ARRAY | UNSIGNED16 | RW | No |
| 2011 | Accelerometer Data Inversion/Negation | ARRAY | UNSIGNED8 | RW | No |
| 2020 | Accelerometer Data Offset | ARRAY | FLOAT32 | RW | No |
| 2030 | Angular Data Resolution | ARRAY | UNSIGNED16 | RW | No |
| 2031 | Angular Data Inversion/Negation | ARRAY | UNSIGNED8 | RW | No |
| 2032 | Angular Data Range | ARRAY | UNSIGNED8 | RW | No |
| 2040 | Angular Data Offset | ARRAY | FLOAT32 | RW | No |
| 2100 | Pitch and Roll Angle Type | VAR | UNSIGNED8 | RW | No |
| 2101 | Tilt Angle Range | VAR | UNSIGNED8 | RW | No |

| | | | | | |
|------|---|-------|------------|----|-----|
| 2102 | Maximum Gravity Acceleration Error | VAR | FLOAT32 | RW | No |
| 2103 | Dynamic Angle Compensation | VAR | UNSIGNED8 | RW | No |
| 2104 | Acceleration Noise Density | VAR | FLOAT32 | RW | No |
| 2105 | Gyro Noise Density | VAR | FLOAT32 | RW | No |
| 2106 | Gyro Random Walk Rate | VAR | FLOAT32 | RW | No |
| 2200 | Initial Pitch Angle | VAR | FLOAT32 | RW | No |
| 2210 | Initial Roll Angle | VAR | FLOAT32 | RW | No |
| 2220 | Mounting Installation | VAR | UNSIGNED8 | RW | No |
| 2230 | Initial Coordinate Rotation Yaw Angle | VAR | FLOAT32 | RW | No |
| 2240 | Initial Coordinate Rotation Pitch Angle | VAR | FLOAT32 | RW | No |
| 2250 | Initial Coordinate Rotation Roll Angle | VAR | FLOAT32 | RW | No |
| 2300 | Auto-Null Command | VAR | UNSIGNED8 | RW | No |
| 2400 | Calibrated Pitch Angle | VAR | FLOAT32 | RO | No |
| 2410 | Calibrated Roll Angle | VAR | FLOAT32 | RO | No |
| 2420 | Calibrated Gyro Sensor X-Axis Bias | VAR | FLOAT32 | RO | No |
| 2430 | Calibrated Gyro Sensor Y-Axis Bias | VAR | FLOAT32 | RO | No |
| 2440 | Calibrated Gyro Sensor Z-Axis Bias | VAR | FLOAT32 | RO | No |
| 2450 | Accel Sensor X-Axis Offset | VAR | FLOAT32 | RO | No |
| 2460 | Accel Sensor Y-Axis Offset | VAR | FLOAT32 | RO | No |
| 2470 | Accel Sensor Z-Axis Offset | VAR | FLOAT32 | RO | No |
| 2500 | RPDO Received Message Process Value | ARRAY | INTEGER16 | RW | Yes |
| 2501 | RPDO Resolution | ARRAY | UNSIGNED16 | RW | No |
| 2502 | RPDO Offset | ARRAY | FLOAT32 | RW | No |
| 3000 | Binary Function Output Field Value | ARRAY | INTEGER16 | RO | Yes |
| 300A | Binary Function Operation | ARRAY | UNSIGNED8 | RW | No |
| 300B | Binary Function Output Scaling | ARRAY | FLOAT32 | RW | No |
| 300C | Binary Function Output Offset | ARRAY | FLOAT32 | RW | No |
| 30x0 | Binary Function x Signal 1 & 2 Source | ARRAY | UNSIGNED8 | RW | No |
| 30x1 | Binary Function x Signal 1 & 2 Is Default | ARRAY | UNSIGNED8 | RW | No |
| 30x2 | Binary Function x Signal 1 & 2 Default Value | ARRAY | FLOAT32 | RW | No |
| 30x3 | Binary Function x Signal 1 & 2 Unary Function | ARRAY | UNSIGNED8 | RW | No |
| 30x4 | Binary Function x Signal 1 & 2 Scale | ARRAY | FLOAT32 | RW | No |
| 30x5 | Binary Function x Signal 1 & 2 Offset | ARRAY | FLOAT32 | RW | No |
| 4000 | Accelerometer Axis Data Field Value | ARRAY | INTEGER16 | RO | Yes |
| 4010 | Accelerometer Measurement Latency | VAR | UNSIGNED16 | RO | Yes |
| 4020 | Accelerometer Figure of Merit | VAR | UNSIGNED8 | RO | Yes |
| 4030 | Pitch Angle Data Field Value | VAR | INTEGER16 | RO | Yes |
| 4040 | Roll Angle Data Field Value | VAR | INTEGER16 | RO | Yes |
| 4050 | Gravity Angle Data Field Value | VAR | INTEGER16 | RO | Yes |
| 4060 | Gravity Acceleration Error | VAR | FLOAT32 | RO | Yes |
| 4070 | Accelerometer Sensor Temperature Data | VAR | INTEGER16 | RO | Yes |
| 4080 | Angle Compensation | VAR | UNSIGNED8 | RO | Yes |
| 4090 | Angle Compensation Inverted | VAR | UNSIGNED8 | RO | Yes |
| 4100 | Gyroscope Data Field Value | ARRAY | INTEGER16 | RO | Yes |
| 4110 | Angular Rate Measurement Latency | VAR | UNSIGNED16 | RO | Yes |
| 4120 | Angular Rate Figure of Merit | VAR | UNSIGNED8 | RO | Yes |
| 4130 | Angular Measurement Latency | VAR | UNSIGNED16 | RO | Yes |
| 4140 | Angular Figure of Merit | VAR | UNSIGNED8 | RO | Yes |
| 4150 | Gyro Sensor Temperature Data | ARRAY | INTEGER16 | RO | Yes |

| | | | | | |
|------|---|-----|------------|----|-----|
| 4200 | Angular Measurement Latency Uncompensated | VAR | UNSIGNED16 | RO | Yes |
| 4210 | Angular Figure of Merit Uncompensated | VAR | UNSIGNED8 | RO | Yes |
| 4220 | Pitch Angle Data Uncompensated | VAR | INTEGER16 | RO | Yes |
| 4230 | Roll Angle Data Uncompensated | VAR | INTEGER16 | RO | Yes |
| 4240 | Gravity Angle Data Uncompensated | VAR | INTEGER16 | RO | Yes |
| 4250 | Gravity Acceleration Error Uncompensated | VAR | FLOAT32 | RO | Yes |
| 4260 | Continuous Signal | VAR | FLOAT32 | RW | Yes |
| 4270 | Discrete Signal | VAR | UNSIGNED32 | RW | Yes |
| 5000 | Power Supply Field Value | VAR | FLOAT32 | RO | Yes |
| 5010 | Processor Temperature Field Value | VAR | FLOAT32 | RO | Yes |
| 5555 | Start in Operational Mode | VAR | BOOLEAN | RW | No |
| 55AA | Start Bootloader | VAR | BOOLEAN | RW | No |
| 5B50 | Change Baud Rate | VAR | UNSIGNED8 | RW | No |
| 5B51 | Change Node ID | VAR | UNSIGNED8 | RW | No |

Where x represents Binary Function 1....10

Further details on each manufacturer object can be found in their respective function block section.

5 FLASHING NEW FIRMWARE

When the new firmware becomes available, the user can replace the inclinometer firmware in the field using the unit's embedded bootloader. The firmware file can be received from Axiomatic on request.

To flash the new firmware, the user should activate the embedded bootloader. To do so, the *Start Bootloader* object (COB-ID 0x55AA) should be set to 1. This will automatically restart the controller and activate the bootloader, allowing the device to be connected with EA.

After automatic reset, the user will see *J1939 Bootloader* ECU in the *J1939 CAN Network* top-level group in the EA. This means that the bootloader is activated and is ready to accept the new firmware.

All the bootloader specific information: controller hardware, bootloader details, and the currently installed application firmware remains the same in the bootloader mode and the user can read it in the *Bootloader Information* group screen, see **Error! Reference source not found.** The information can be slightly different for different versions of the bootloader.

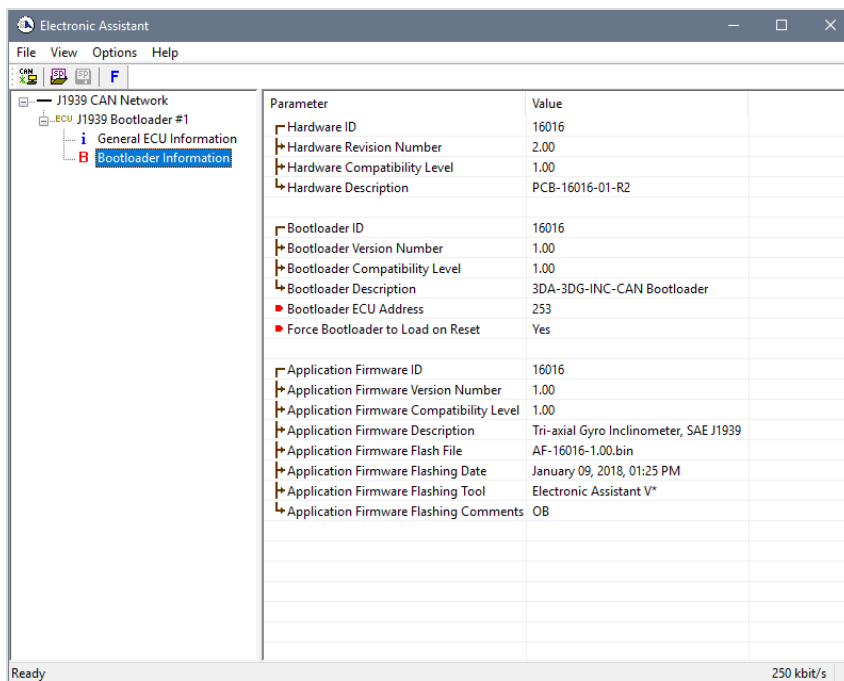

Figure 25. Bootloader Information Screen

To flash the new firmware, the user should click on **F** toolbar icon or from the *File* menu select the *Open Flash File* command. The *Open Application Firmware Flash File* dialog will appear. Pick up the flash file with the new inclinometer firmware and confirm the selection by pressing the *Open* button. The *Flash Application Firmware* dialog window will appear¹, see Figure 26.

¹ In this example, instead of the new firmware the old firmware is being simply re-flashed.

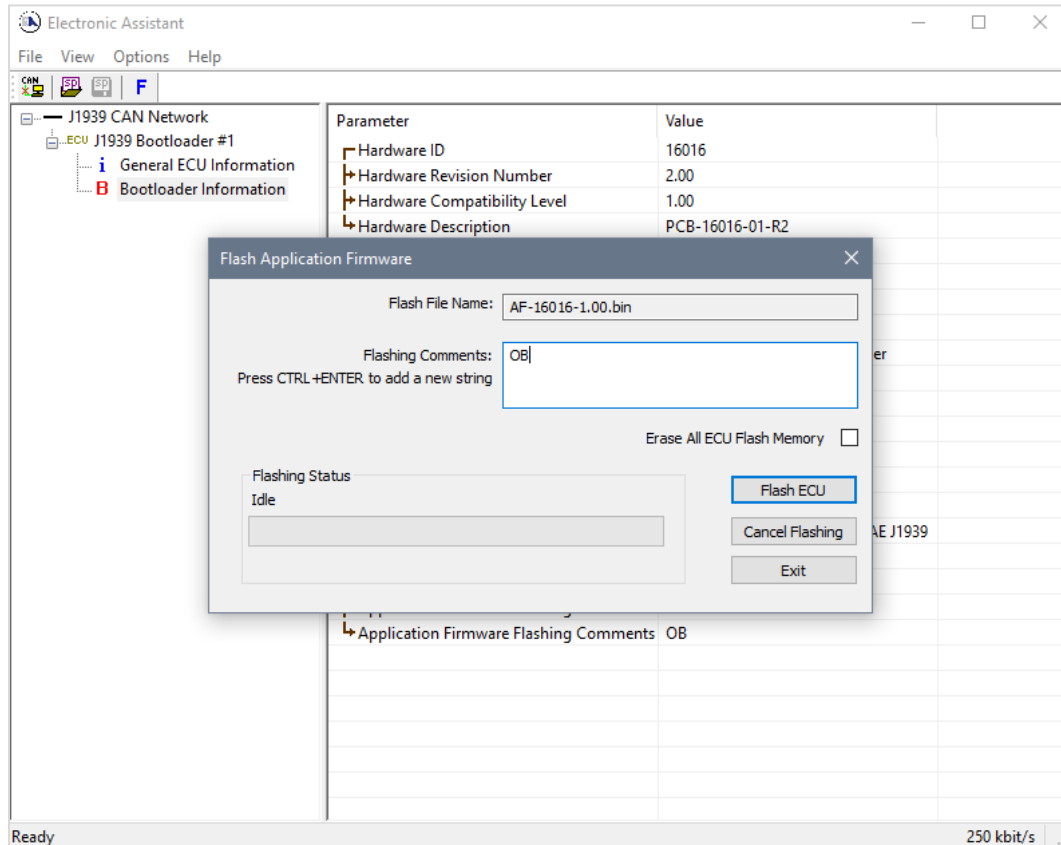

Figure 26. Flashing New Firmware. Preparation

Now the user can add any comments to the flashing operation in the *Flashing Comments* field. They will be stored in the *Bootloader Information* group after flashing.

The user can also check the *Erase All ECU Flash Memory* flag to erase all inclinometer flash memory. This operation, used in other products to reset configuration parameters kept in the flash memory to their default values, has no effect on this product. This is because the configuration parameters of the inclinometer are kept in a separate EEPROM memory.

The flashing operation will not normally change the configuration parameters. The default values will be set only to the new configuration parameters introduced by the new firmware. The old configuration parameters will keep their original values unless otherwise is stated in the user manual.

To start flashing, press the *Flash ECU* button. A reminder that the old application firmware will be destroyed by the flashing operation will appear. Press *Ok* to continue and watch the dynamics of the flashing operation in the *Flashing Status* field. When flashing is done, the following screen will appear prompting the user to reset the ECU, see Figure 27.

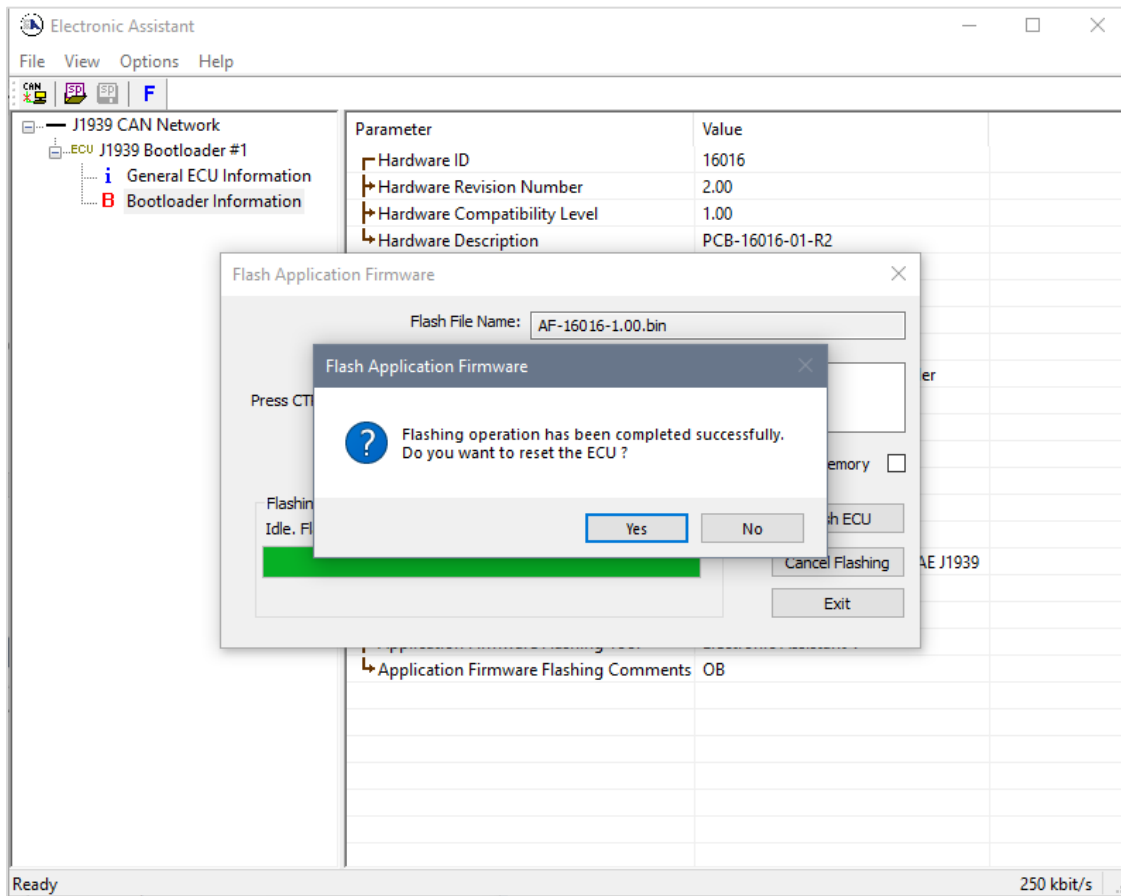

Figure 27. Flashing New Firmware. Final Reset

After clicking **Yes** to proceed, EA will no longer connect to the device since the firmware uses CANopen communications, and not J1939 CAN.

For more information, refer to the *J1939 Bootloader* section of the EA user manual.

6 TECHNICAL SPECIFICATIONS

6.1 Performance Parameters

Stated at 25°C unless otherwise specified.

6.1.1 Angular Measurements

Inclinometers AX060901, AX060911 are designed to measure all inclination angles with the gyro compensation enabled by default.

6.1.1.1 AX060900, AX062008

Table 57. AX060900, AX062008 Angular Measurement Parameters

| Parameter | Value | Remarks |
|------------------------------|---|---|
| Measurement Range | ±180° – Pitch & Roll 0...180° – Gravity | Defaults: <ul style="list-style-type: none"> AX060900, ±90° Pitch & Roll; AX062008, ±90° Pitch & ±180° Roll. |
| Gyro Compensation | Pitch, Roll, Gravity | AX060900 |
| | Roll | AX062008 |
| Resolution | 0.07° | Effective Resolution (3.46*NoiseRMS). Typical with gyro compensation. Typical without gyro compensation at Cut-Off Frequency Fc=5Hz. |
| Initial Accuracy | ±1.5° | Maximum |
| Temperature Drift | ±1.3° | Maximum, in the full temperature range: -40...85°C |
| Nonlinearity | ±0.15% | Typical |
| Cross-Axis Sensitivity | ±0.5% | Maximum |
| Cut-off frequency, Fc | 1...35 Hz, 5 Hz default; 8 Hz with gyro compensation | User selectable (except for the gyro compensation) |
| Maximum Dynamic Acceleration | ±2g | Maximum short-term linear acceleration per axis with gyro compensation |

6.1.1.2 AX060910, AX062018

Table 58. AX060910, AX062018 Angular Measurement Parameters

| Parameter | Value | Remarks |
|-------------------|--|---|
| Measurement Range | ±180° – Pitch & Roll 0...180° – Gravity | Defaults: <ul style="list-style-type: none"> AX060910, ±90° Pitch & Roll; AX062018, ±90° Pitch & ±180° Roll. |
| Gyro Compensation | Pitch, Roll, Gravity | AX060910 |
| | Roll | AX062018 |
| Resolution | 0.06° | Effective Resolution (3.46*NoiseRMS). Maximum with gyro compensation. Maximum without gyro compensation at Cut-Off Frequency Fc=5Hz |
| Initial Accuracy | ±2.0° | Maximum |
| Temperature Drift | ±3.0° | Maximum, in the full temperature range: |

| Parameter | Value | Remarks |
|------------------------------|---|--|
| | | -40...85°C |
| Nonlinearity | ±0.1% | Maximum |
| Cross-Axis Sensitivity | ±1.0% | Maximum |
| Cut-off frequency, Fc | 1...35 Hz, 5 Hz default; 8 Hz with gyro compensation | User selectable (except for the gyro compensation) |
| Maximum Dynamic Acceleration | ±6g | Maximum short-term linear acceleration per axis with gyro compensation |

6.1.2 Angular Rate Measurements

6.1.2.1 AX060901

Table 59. AX060901 Angular Rate Measurement Parameters

| Parameter | Value | Remarks |
|--------------------------|----------------------------|---|
| Measurement Range | ±125°/s | Only Roll Angular Rate in AX062008 |
| Resolution | 0.08°/s | Effective Resolution (3.46*NoiseRMS). Typical at Cut-Off Frequency Fc=5Hz |
| Offset Error | ±1°/s | Maximum |
| Offset Temperature Drift | ±0.8°/s | Maximum, in the full temperature range: -40...85°C |
| Sensitivity Error | ±2.5% | Maximum, in the full temperature range: -40...85°C |
| Nonlinearity | ±0.5°/s | Typical |
| Cross-Axis Sensitivity | ±1.5% | Maximum |
| Cut-off frequency, Fc | 1...35 Hz, 5 Hz default | User selectable |

6.1.2.2 AX060911

Table 60. AX060911 Angular Rate Measurement Parameters

| Parameter | Value | Remarks |
|--------------------------|----------------------------|---|
| Measurement Range | ±300°/s | Only Roll Angular Rate in AX062018 |
| Resolution | 0.2°/s | Effective Resolution (3.46*NoiseRMS). Maximum at Cut-Off Frequency Fc=5Hz |
| Offset Error | ±1.3°/s | Maximum |
| Offset Temperature Drift | ±0.6°/s | Maximum, in the full temperature range: -40...85°C |
| Sensitivity Error | ±3% | Maximum, in the full temperature range: -40...85°C |
| Nonlinearity | ±0.5°/s | Maximum, in the full temperature range: -40...85°C |
| Cross-Axis Sensitivity | ±1.7% | Maximum |
| Cut-off frequency, Fc | 1...35 Hz, 5 Hz default | User selectable |

6.2 Power Supply Input

Table 61. Power Supply

| Parameter | Value | Remarks |
|-----------------------------|----------------|------------------------------------|
| Supply Voltage | 9...36 VDC | 12V, 24V – nominal. |
| Supply Current ¹ | 40 mA 75 mA | Maximum at 24V. Maximum at 12V. |

| | | |
|------------|------------------------------|--|
| Protection | Reverse polarity, Transients | |
|------------|------------------------------|--|

¹ CAN bus is connected.

6.3 CAN Output

Table 62. CAN Parameters

| Parameter | Value | Remarks |
|-------------------------|--|--|
| Number of ports | 1 CAN Port | To output data and change the internal configuration of the inclinometer |
| Communication standards | CiA CANopen | Full support for a CANopen Node ID. |
| | ISO 11898 | 120Ohm terminated twisted pair, baud rate up to 1Mbit/s. External 120Ohm termination is required. |
| | Bosch CAN protocol specification 2.0, Part A, B. | For the internal CAN controller. |
| Protection | Short circuit to ground | |
| | Connection to the power supply | Only for 12V systems, 24V max. |

6.4 General Specifications

Table 63. General Specifications

| Parameter | Value | Remarks |
|--------------------------|---|---|
| Sensor Type | MEMS gyro and MEMS accelerometer | |
| Internal Logic | User Configurable with standard CANopen tools. EDS file is provided. | Axiomatic Electronic Assistant®, P/N: AX070502. |
| Operating Temperature | -40...+85 °C | Industrial temperature range. |
| Environmental Protection | IP67 | IEC 60529 with mated connectors. |
| Vibration | MIL-STD-202G, method 204D, test condition C. Sinusoidal. 10G Peak, 10Hz-2000Hz-10Hz, 20 Minutes, 8hrs/axis. Custom, meets or exceeds: MIL-STD-202G, method 214A, test condition I/B. Random. 7.68 Grms, 10Hz to 2000Hz, 8hrs/axis. | |
| Shock | Custom, based on: MIL-STD-202G, method 213B, test condition A. Half-Sine. 50G Peak, 9ms, 8pulses/axis. | |
| Size | 4.41 x 2.25 x 1.32 in (112 x 57 x 34 mm) | See dimensional drawing. |
| Weight | 0.80 lb. (0.36 kg) | |

6.5 Enclosure

All inclinometers use the same cast aluminum enclosure with two 5-pin M12 A-coded round connectors, see *AX060911 Dimensional Drawing*, as an example, in Figure 28. Other inclinometers have a different part number on the label and vertical mount versions have a different unit orientation.

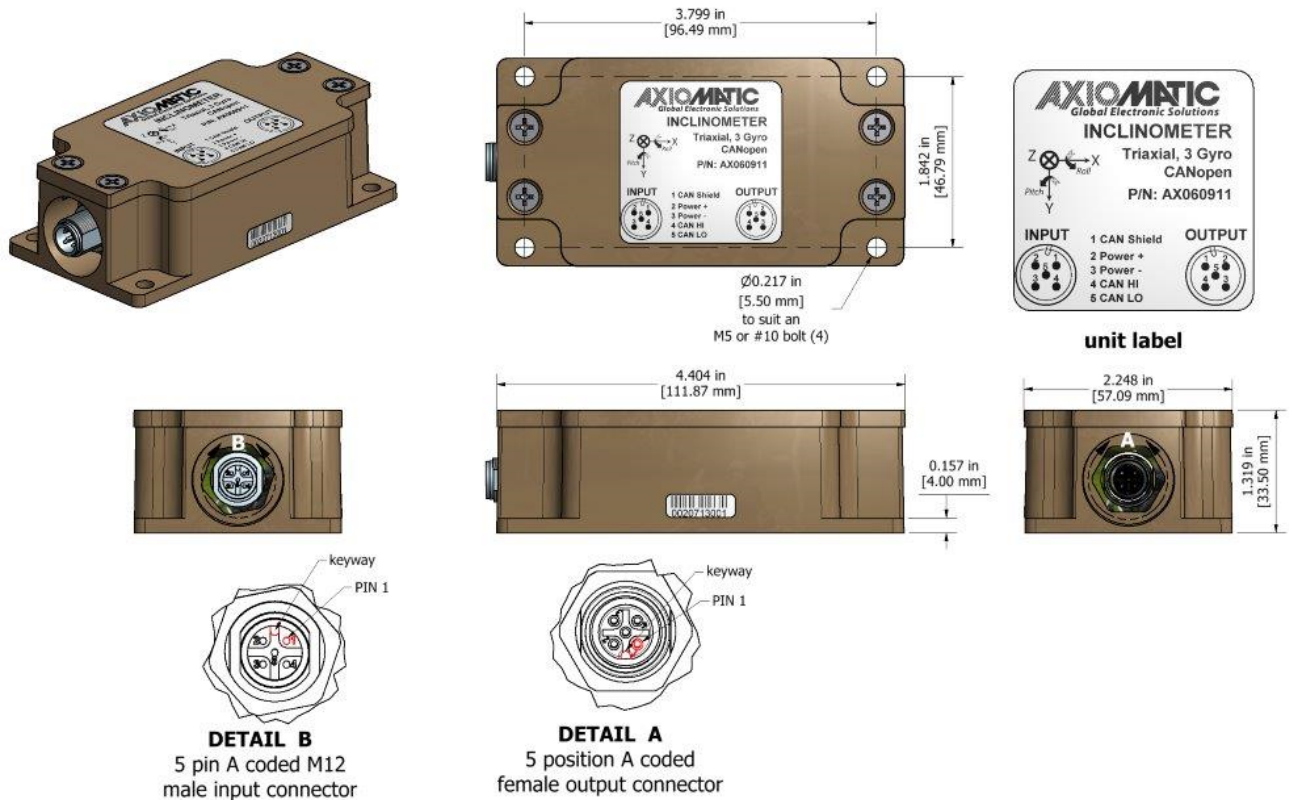

Figure 28. AX060911 Dimensional Drawing

The connector pinout for all inclinometers is the same, see Figure 29. Use mating connectors compliant with IEC 61076-2-101:2012.

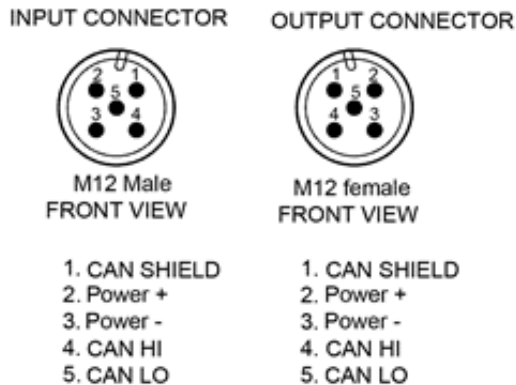

Figure 29. Connector Pinouts

If only one connector is used, an M12 sealing cap with IP67 rating should be installed on the unused connector. PROT-M12 FB – 155538 from PHOENIX CONTACT is recommended for the unused output M12 connector, Axiomatic P/N AX070140.

There is only one CAN port supported by the unit. Both CAN connectors are electrically connected together to facilitate cable routing in the user system. A mating plug with CAN

termination, P/N: AX070114, can be ordered for applications requiring a termination of the CAN network.

6.6 Unit Orientation

The unit coordinates, together with the Pitch and Roll directions are shown on the inclinometer label.

6.6.1 Horizontal Unit Orientation

The horizontal unit orientation is used in the normally (horizontally) mounted inclinometers: AX060901 and AX060911, see Figure 30.

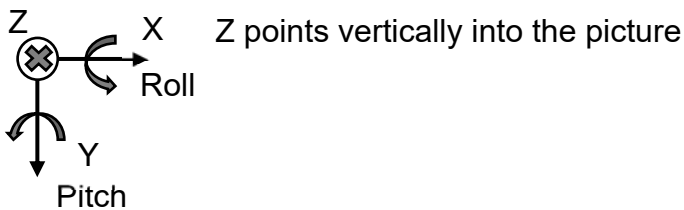

Figure 30. Horizontal Unit Orientation

6.7 Installation

See mechanical installation information on the dimensional drawing.

The CAN wiring is considered intrinsically safe. All field wiring should be suitable for the operating temperature range of the unit. CAN wiring may be shielded using a shielded twisted conductor pair and the shield must be connected to the CAN_SHIELD pin.

7 THIRD PARTY SOFTWARE LICENSE NOTICES

This section contains Third Party Software License Notices and/or Additional Terms and Conditions for licensed third-party software components included in the Tri-Axial Gyro Inclinometer firmware.

Table 64. Third Party Software License Notices

| Third Party Software | License Notice/Terms |
|---|---|
| STMicroelectronics microcontroller support software | <p>COPYRIGHT(c) 2017 STMicroelectronics Redistribution and use in source and binary forms, with or without modification, are permitted provided that the following conditions are met: Redistributions of source code must retain the above copyright notice, this list of conditions and the following disclaimer. Redistributions in binary form must reproduce the above copyright notice, this list of conditions and the following disclaimer in the documentation and/or other materials provided with the distribution. Neither the name of STMicroelectronics nor the names of its contributors may be used to endorse or promote products derived from this software without specific prior written permission. THIS SOFTWARE IS PROVIDED BY THE COPYRIGHT HOLDERS AND CONTRIBUTORS "AS IS" AND ANY EXPRESS OR IMPLIED WARRANTIES, INCLUDING, BUT NOT LIMITED TO, THE IMPLIED WARRANTIES OF MERCHANTABILITY AND FITNESS FOR A PARTICULAR PURPOSE ARE DISCLAIMED. IN NO EVENT SHALL THE COPYRIGHT HOLDER OR CONTRIBUTORS BE LIABLE FOR ANY DIRECT, INDIRECT, INCIDENTAL, SPECIAL, EXEMPLARY, OR CONSEQUENTIAL DAMAGES (INCLUDING, BUT NOT LIMITED TO, PROCUREMENT OF SUBSTITUTE GOODS OR SERVICES; LOSS OF USE, DATA, OR PROFITS; OR BUSINESS INTERRUPTION) HOWEVER CAUSED AND ON ANY THEORY OF LIABILITY, WHETHER IN CONTRACT, STRICT LIABILITY, OR TORT (INCLUDING NEGLIGENCE OR OTHERWISE) ARISING IN ANY WAY OUT OF THE USE OF THIS SOFTWARE, EVEN IF ADVISED OF THE POSSIBILITY OF SUCH DAMAGE.</p> <p>Licensed under MCD-ST Liberty SW License Agreement V2, (the "License"); You may not use this file except in compliance with the License. You may obtain a copy of the License at: http://www.st.com/software_license_agreement_liberty_v2 Unless required by applicable law or agreed to in writing, software distributed under the License is distributed on an "AS IS" BASIS, WITHOUT WARRANTIES OR CONDITIONS OF ANY KIND, either express or implied. See the License for the specific language governing permissions and limitations under the License.</p> |
| FreeRTOS V9.0.0 | <p>Copyright (C) 2016 Real Time Engineers Ltd. All rights reserved FreeRTOS is free software; you can redistribute it and/or modify it under the terms of the GNU General Public License (version 2) as published by the Free Software Foundation >>!AND MODIFIED BY!<< the FreeRTOS exception. >>! NOTE: The modification to the GPL is included to allow you to !<< >>! distribute a combined work that includes FreeRTOS without being !<< >>! obliged to provide the source code for proprietary components !<< >>! outside of the FreeRTOS kernel. !<<</p> |

| | |
|----------------------|---|
| Third Party Software | License Notice/Terms |
| | FreeRTOS is distributed in the hope that it will be useful, but WITHOUT ANY WARRANTY; without even the implied warranty of MERCHANTABILITY or FITNESS FOR A PARTICULAR PURPOSE. Full license text is available on the following link: http://www.freertos.org/a00114.html |



OUR PRODUCTS

Actuator Controls
Automotive Ethernet Converters
Battery Chargers
CAN bus Controls
CAN/Wifi, CAN/Bluetooth
Current/Voltage Converters
DC/DC Power Converters
Engine Temperature Scanners
Ethernet/CAN Converters,
Switches
Fan Drive Controllers
Gateways, CAN/Modbus Protocols
Gyroscope Inclinometers
Hydraulic Valve Controllers
Inclinometers, Triaxial
I/O Controls
LVDT Simulators
Machine Controls
Motor Controls
Power Supplies
PWM Signal Converters/Isolators
Resolver Signal Conditioners
Service Tools
Signal Conditioners, Converters
Strain Gauge CAN Controls
Surge Suppressors

OUR COMPANY

Axiomatic provides electronic machine controls, components, and systems to the off-highway, commercial vehicle, electric vehicle, power generator set, material handling, renewable energy and industrial OEM markets.

We provide efficient, innovative solutions that focus on adding value for our customers.

We innovate with engineered and off-the-shelf machine controls.

We emphasize service and partnership with our customers, suppliers, and employees to build long term relationships and mutual trust.

QUALITY DESIGN AND MANUFACTURING

Axiomatic in Canada operates an ISO 9001:2015 registered design and manufacturing facility.

SERVICE

All products to be returned to Axiomatic require a Return Materials Authorization Number (RMA#). Please request an RMA# from rma@axiomatic.com.

Please provide the following information when requesting an RMA number:

- Serial number, part number
- Axiomatic invoice number and date
- Hours of operation, description of problem
- Wiring set up diagram, application
- Other comments as needed

WARRANTY, APPLICATION APPROVALS/LIMITATIONS

Axiomatic Technologies Corporation reserves the right to make corrections, modifications, enhancements, improvements, and other changes to its products and services at any time and to discontinue any product or service without notice. Customers should obtain the latest relevant information before placing orders and should verify that such information is current and complete. Users should satisfy themselves that the product is suitable for use in the intended application. All our products carry a limited warranty against defects in material and workmanship. Please refer to our Warranty, Application Approvals/Limitations and Return Materials Process as described on www.axiomatic.com/service.html.

CONTACTS

Axiomatic Technologies Corporation

5915 Wallace Street
Mississauga, ON
CANADA L4Z 1Z8
TEL: +1 905 602 9270
FAX: +1 905 602 9279
www.axiomatic.com

Axiomatic Technologies Oy

Höytämöntie 6
33880 Lempäälä
FINLAND
TEL: +358 103 375 750
FAX: +358 3 3595 660
www.axiomatic.fi