

USER MANUAL

Electronic Assistant

P/N: AX070500 – Windows Software

USB-CAN Converters

P/N: AX070501, AX070505 – Hardware Interfaces

Electronic Assistant Kits

P/N: AX070502 – USB-CAN Converter AX070501,
2 Cables, Installation Instructions

P/N: AX070505K – USB-CAN Converter AX070505,
2 Cables, Installation Instructions

In Europe:
Axiomatic Technologies Oy
Höytämöntie 6
33880 Lempäälä - Finland
Tel. +358 103 375 750
Fax. +358 3 3595 660
www.axiomatic.fi

In North America:
Axiomatic Technologies Corporation
5915 Wallace Street
Mississauga, ON Canada L4Z 1Z8
Tel. 1 905 602 9270
Fax. 1 905 602 9279
www.axiomatic.com

ACRONYMS

BLDC	Brushless DC electric motor
CAN	Controller Area Network
CD	Compact Disk
DC	Direct Current
DM	Diagnostic message. Defined in J1939/73 standard
DTC	Diagnostic Trouble Code
EA	Electronic Assistant
ECU	Electronic control unit (from SAE J1939 standard)
EMI	Electromagnetic Interference
FS	Full Speed
HS	High Speed
HVCI	Hypervisor-Protected Code Integrity
IP	Ingress Protection
LED	Light-emitting diode
MAP	Memory Access Protocol. Defined in the J1939-71 standard
PC	Personal Computer
PGN	Parameter Group Number. Defined in J1939/73 standard
P/N	Part Number
RTD	Resistance Temperature Detector
RTU	Remote terminal unit
RS	Recommended Standard (in RS-232)
SAE	Society of Automobile Engineers
SDK	Software Development Kit
TC	Thermocouple
TCP/IP	Transmission Control Protocol/Internet Protocol
UM	User Manual
USB	Universal Serial Bus
XML	Extensible Markup Language

TABLE OF CONTENTS

1	OVERVIEW.....	4
2	USB-CAN CONVERTERS	5
2.1	CAN Bus Connection	5
2.1.1	Workbench Connection.....	6
3	ELECTRONIC ASSISTANT KITS	7
4	SOFTWARE INSTALLATION	8
4.1	System Requirements.....	8
4.2	File location.....	8
4.3	USB-CAN Drivers	9
4.3.1	Installation Example.....	10
4.4	Electronic Assistant.....	13
4.4.1	Electronic Assistant Hardware Support.....	14
4.5	Additional Software	14
5	USING THE ELECTRONIC ASSISTANT.....	15
5.1	Hardware Requirements	15
5.2	Connecting to J1939 CAN.....	15
5.3	General ECU Information Group.....	17
5.4	Reading Configuration Parameters.....	19
5.5	Editing Configuration Parameters	19
5.6	Multiple ECU Instances.....	20
5.7	Changing ECU Address.....	21
5.8	Saving Configuration Parameters in Setpoint File.....	22
5.9	Reading Configuration Parameters from Setpoint File.....	23
5.10	Programming Configuration Parameters from Setpoint File.....	24
5.11	Comparing ECU Configuration Parameters with Setpoint File.....	25
5.12	J1939 Bootloader.....	26
5.13	Flashing New Application Firmware.....	28
6	APPENDIX A.....	34
7	APPENDIX B.....	35
8	APPENDIX C	41
9	APPENDIX D	43
10	VERSION HISTORY	46

1 OVERVIEW

The Electronic Assistant (EA) is a software tool for configuring Axiomatic J1939 CAN units. It runs on a PC and, by default, uses one of Axiomatic USB-CAN converters to connect to the CAN bus. Other interface converters can be used as well, see APPENDIX A.

Upon being connected to the bus, the EA will find all the Electronic Control Units (ECUs) on the bus and recognize those manufactured by Axiomatic. From there, a user has easy access to all configuration parameters, a.k.a. setpoints, in a particular unit. With the EA, viewing and changing the configuration parameters is made easy and intuitive. Using this tool, a user can quickly configure an Axiomatic ECU for the desired performance over a wide variety of applications.

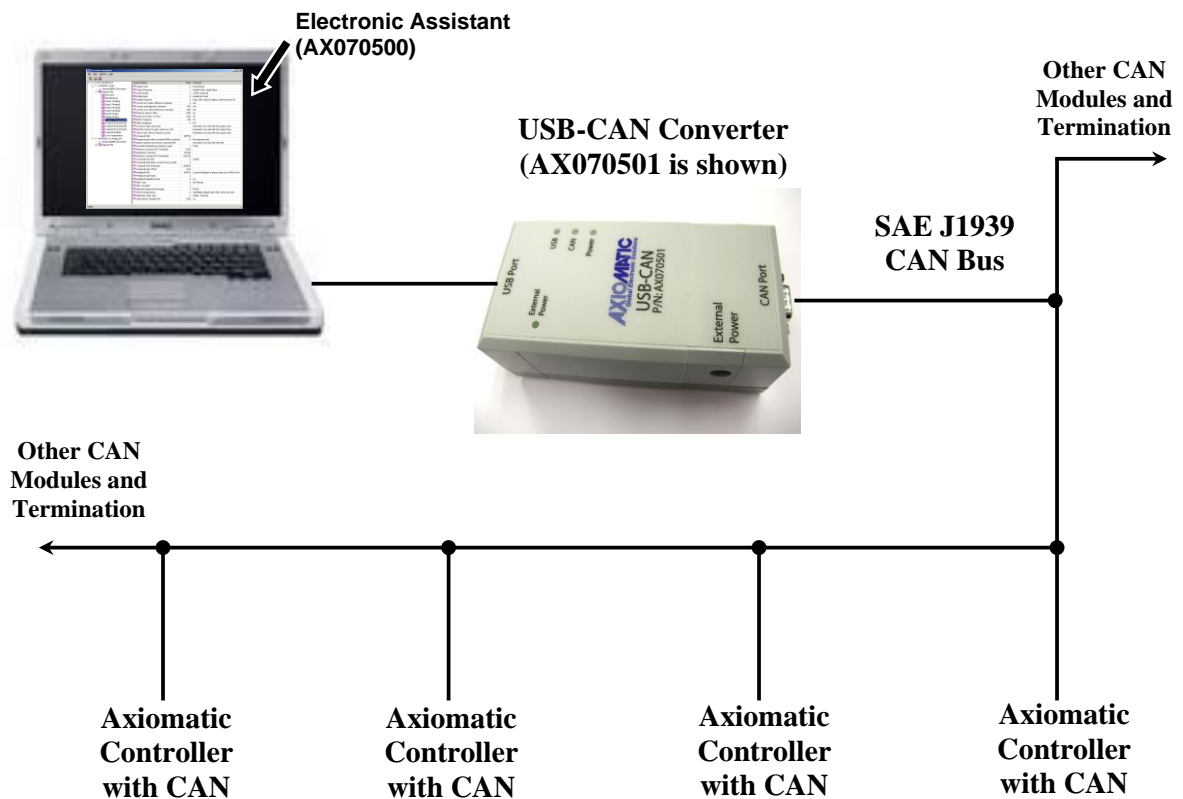

Network Termination: It is necessary to terminate the network with external termination resistors. The resistors are 120 Ohm, 0.25W minimum, metal film or similar type. They are placed between CAN_H and CAN_L terminals at both ends of the network. CAN modules should be powered; no power is transmitted over CAN bus.

Figure 1-1. Electronic Assistant and Axiomatic USB-CAN Converter as part of J1939 Network

Axiomatic units supporting the *J1939 Bootloader* can be flashed with the new application firmware over the CAN bus using the EA, see *Flashing New Application Firmware* section.



The user should set up CAN network with necessary termination resistors and power up the Axiomatic unit to change configuration parameters or to flash a new application firmware.

The EA supports SAE J1939 CAN bus. It is assumed, that the user is familiar with the J1939 group of standards; the terminology from these standards is widely used in this manual.

2 USB-CAN CONVERTERS

There are two *Axiomatic USB-CAN Converters*, AX070501 and AX070505, designed to provide an interface between a PC and a generic CAN bus. Both can be used with EA.

The converters are plugged one side to a USB PC port and the other side to a CAN bus through a DB9 CAN connector. The AX070501 converter supports only USB Full-Speed (FS) communication (up to 12Mbit/s), while the AX070505 converter runs at USB High-Speed (HS) with up to 480Mbit/s communication rate. The AX070501 can also be powered from an external power supply without drawing current from the USB port. Due to low supply current, this feature is rarely used in AX070501 and is considered obsolete.

The AX070501 converter full technical description can be found in APPENDIX D. The AX070505 converter technical description is presented in its own user manual, UMAX070505.

2.1 CAN Bus Connection

Axiomatic USB-CAN Converters are connected to a CAN bus the following way.

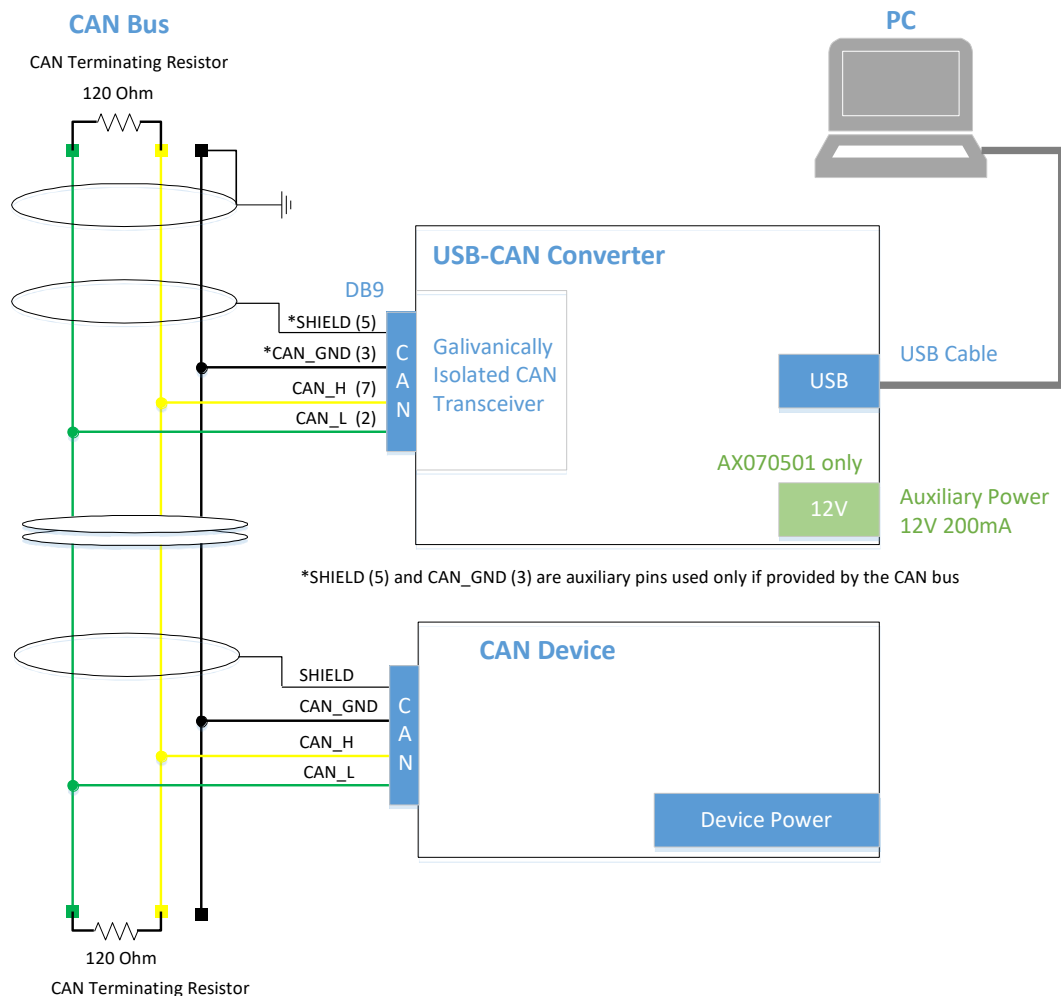

Figure 2-1. Connecting Axiomatic USB-CAN Converter to CAN Bus

The CAN bus line contains a twisted differential signal pair CAN_H, CAN_L, and auxiliary CAN_GND and SHIELD conductors. The devices are connected to the bus line using short-length stubs. The twisted pair CAN_H, CAN_L is terminated on both sides with 120 Ohm resistors. In some cases, the terminating resistor can be embedded in the last CAN device connected directly to the bus line.

2.1.1 Workbench Connection

For configuring CAN devices on a workbench, when space is limited and a dedicated CAN bus is not used, the user can directly connect CAN_H and CAN_L signals of the device to CAN_H and CAN_L signals of the USB-CAN converter using a short (less than 1m) pair of wires. It is also necessary to connect at least one 120 Ohm resistor in parallel with CAN_H and CAN_L conductors for normal operation of CAN transceivers.

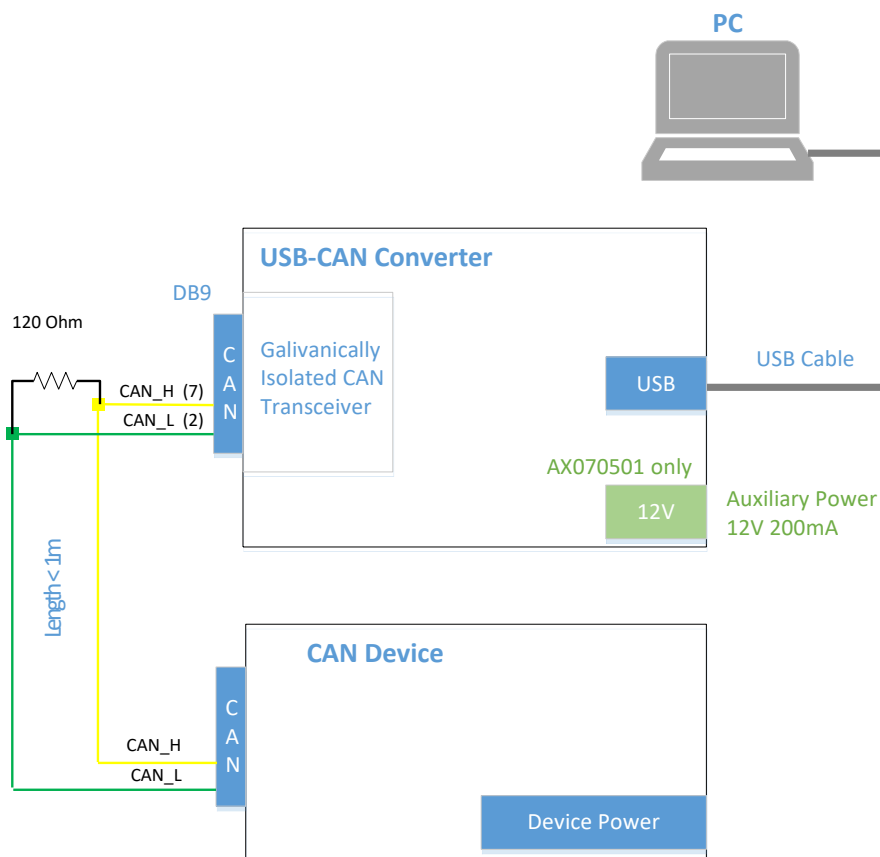

Figure 2-2. Connecting Axiomatic USB-CAN Converter to CAN Device on Workbench

The user can extend this configuration, if necessary, by adding several CAN devices in parallel, provided that the summary length of CAN_H and CAN_L signal wires for all devices is kept short (less than 1m).

If longer wires are used, a standard CAN bus connection with two-side 120 Ohm termination is required, see Figure 2-1.

3 ELECTRONIC ASSISTANT KITS

Axiomatic prepacked all hardware necessary to work with Axiomatic products in EA kits for the customers' convenience. Two EA kits are available depending on the included USB-CAN converter p/n.

Kit p/n	Contents
AX070502	<ul style="list-style-type: none">• USB-CAN Converter, P/N: AX070501• USB Cable 5 ft (1.5 m), P/N: CBL-USB-AB-MM-1.5• CAN Cable with female DB-9 12 in (30 cm), P/N: CAB-AX070501• Installation Instructions
AX070505K	<ul style="list-style-type: none">• USB-CAN Converter, P/N: AX070505• USB Cable 3 ft (0.9 m), P/N: CBL-USB2.0A-MICROB-0.9M• CAN Cable with female DB-9 12 in (30 cm), P/N: CAB-AX070501• Installation Instructions

The *Installation Instructions* contain instructions for downloading: EA software, this user manual, and the USB-CAN Converter drivers from the Axiomatic website www.axiomatic.com.

The user can also download CAN bus monitoring software together with the USB-CAN Converter SDK from the Axiomatic website, see Additional Software section.

4 SOFTWARE INSTALLATION

4.1 System Requirements

The Electronic Assistant (EA) and Axiomatic USB-CAN Converter drivers work with Microsoft Windows 32-bit and 64-bit operating systems, starting from Windows XP SP3¹. Support for Linux and other non-Windows operating systems is not provided.

¹ Support for Windows 2000 was removed starting from EA version 5.15.127.0.

4.2 File location

The most recent version of the installation software together with this user manual can be downloaded from the *Customer Downloads* section of the Axiomatic website at www.axiomatic.com. A separate Electronic Assistant installation CD, AX070502IN, is no longer supported.

To access the *Customer Downloads* section, go to the *Login* tab on the Axiomatic website main page:



Figure 4-1. Logging to Axiomatic Website

Enter the following password (case sensitive): **trillium**

Select *EA Downloads* in the *Customer Downloads* section at the top of the screen:

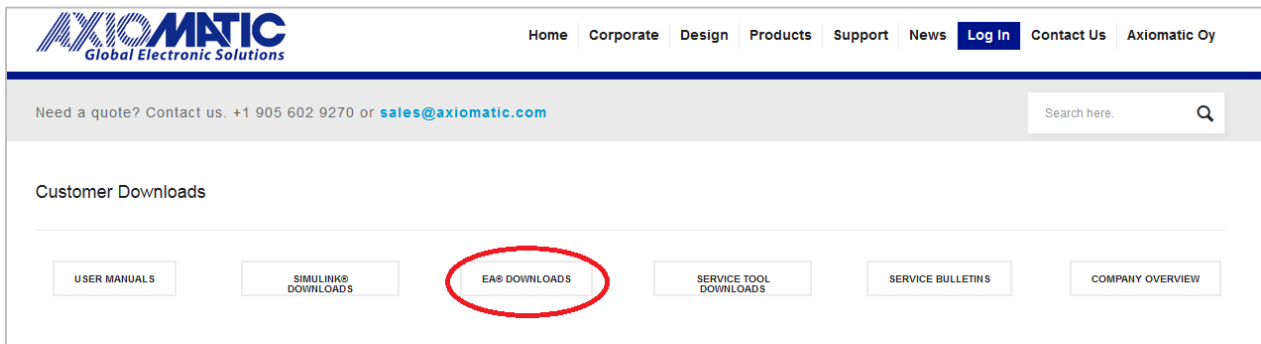

Figure 4-2. Customer Downloads Selection

This will bring you to the *Electronic Assistant Downloads* section:

Electronic Assistant® Downloads		
Electronic Assistant® Service Tool	Type	Downloads
Software License Agreement	Document	License Agreement Axiomatic
Electronic Assistant® and USB-CAN Converter	User Manual	UMAX07050X
Using the EA with Windows 7	Application Note	EA and Windows 7
Electronic Assistant®	Program	ElectronicAssistantSetup V5.13.91.0
USB-CAN Drivers	Drivers	USBCANDrivers
CAN Assistant – Scope	User Manual	UMAX070501SCO
CAN Assistant – Scope	Program	CANAssistantScopeSetup V3.1.0
CAN Assistant - Visual	User Manual	UMAX070501VIS
CAN Assistant - Visual	Program	CANAssistantVisualSetup V2.0.1
CAN Assistant – SDK (Software Development Kit)	User Manual	UMAX070501SDK
CAN Assistant – SDK (Software Development Kit)	Program	USBCAN SDK V1.03
Declaration of Conformity - RoHS Directive	DOC	DOC-RoHS-AX070502

Figure 4-3. EA Downloads Section¹

¹The list of downloads is not up to date.

Select and download the required software or documentation.

4.3 USB-CAN Drivers

Both Axiomatic USB-CAN Converters p/n AX070501 and AX070505 use the same drivers. A zip file with Windows 32-bit and 64-bit driver package can be downloaded from the *Electronic Assistant Downloads* section on the Axiomatic website. It is marked as *USBCANDrivers* in Figure 4-3.

After the zip file is downloaded, it should be unzipped at a temporary location on the user's PC.

The current Axiomatic driver, from the driver package version 1.1.0.1, does not support HVCI (Hypervisor-Protected Code Integrity) in Windows 10 or higher. The user should ensure that HVCI, also known as Memory Integrity, is disabled before installing this driver. Otherwise, the

driver installation will end up with an error reporting that the driver may be corrupted or missing.

To disable HVCI in Windows 10 or higher, the user should turn off *Memory integrity* feature on the *Core isolation* page of the *Windows Security* settings. The *Core isolation* page can be accessed from the *Start* menu by selecting: *Start, Settings, Update & Security, Windows Security, Device Security* and then under *Core isolation*, selecting *Core isolation details*.

Once the user plugs a USB-CAN converter in one of USB PC ports, Windows will automatically recognize a new device and start a hardware installation wizard. The user should direct the wizard to the driver installation script *AX070501.inf* located in the root folder of the unzipped driver package. The AX070505 converter uses the same *AX070501.inf* driver installation script.

After successful installation of the driver, the converter is ready for use. The *USB LED* on the front panel of the AX070501 USB-CAN Converter will turn green. For the AX070505 converter, the *Status LED* on the front panel will change colour from yellow to green indicating that the converter is ready for use.

4.3.1 Installation Example

An example of the Axiomatic USB-CAN Converter driver installation for Windows 7, 64-bit, is presented below.



The user should have Administrative privilege on their PC account to install a device driver.

1. Download and unzip the driver package from the Axiomatic website in a temporary ...*\Downloads\USBCANDriver* folder.
2. Unplug, wait ten seconds and then plug back in the USB cable of the Axiomatic USB-CAN Converter. For AX070501 converter, the *Power LED* on the front panel should turn green. For AX070505 converter, the *Status LED* on the front panel should turn yellow.
3. Go to *Start, Control Panel, System and Security, Device Manager* menu and locate *USBCAN Converter* in the *Other devices* group.

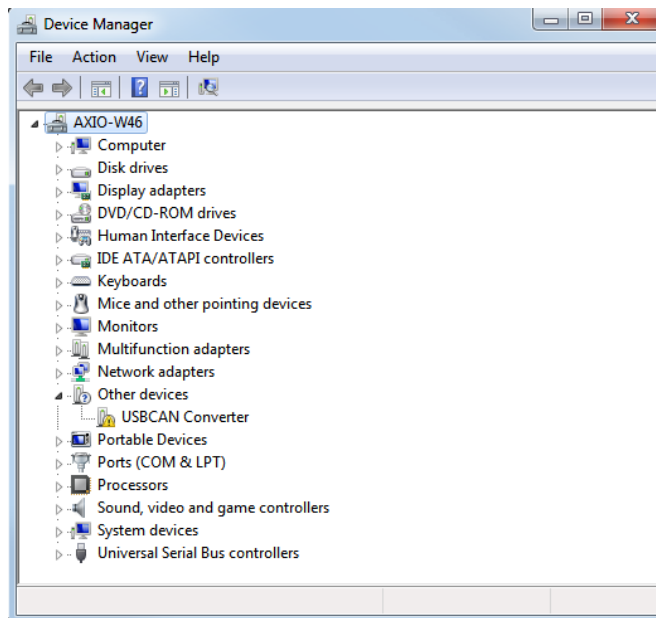

Figure 4-4. Driver Installation. Device Manager Screen

4. Double click on the *USBCAN Converter*. The Windows will open the *USBCAN Converter Properties* window.

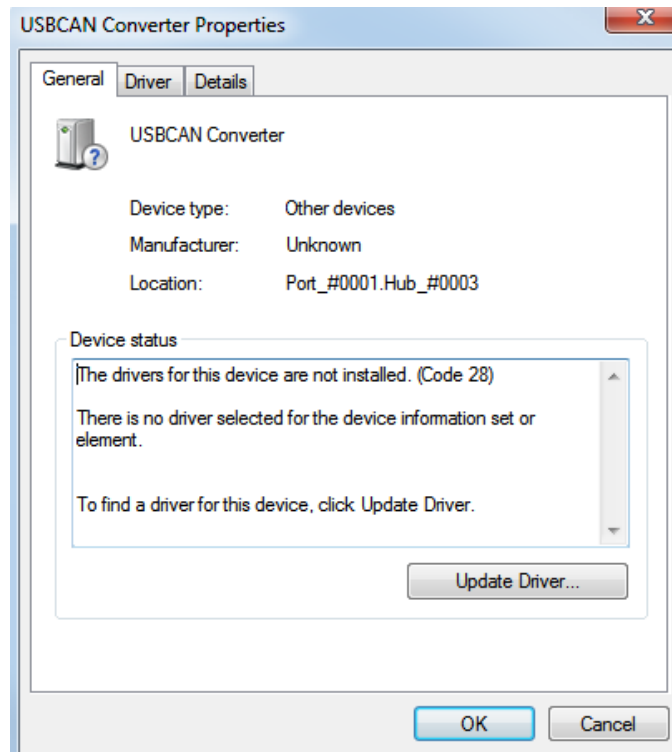

Figure 4-5. Driver Installation. USB-CAN Converter Properties Window

5. Click on *Update Driver...* button to launch the update driver wizard. The *Update Driver Software – USBCAN Converter* window will appear.

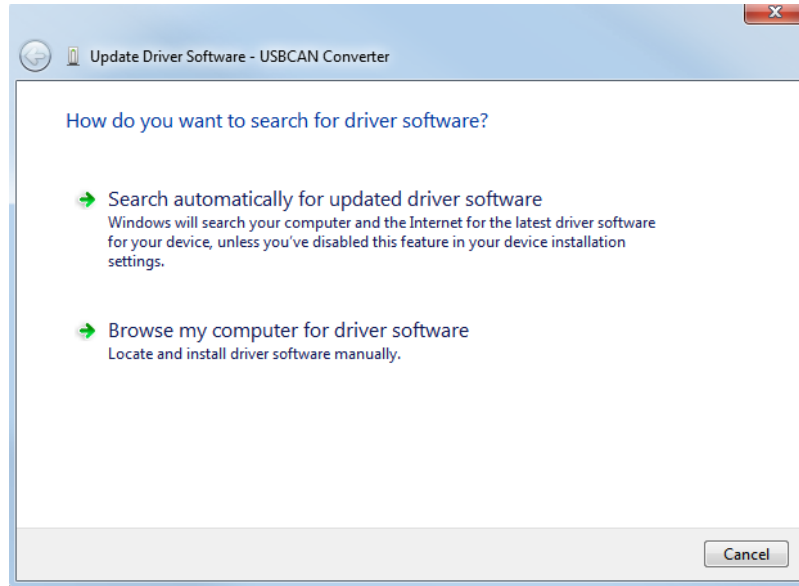

Figure 4-6. Driver Installation. Driver Installation Wizard Window

6. Click on *Browse my computer for driver software*. Go to the ... \Downloads\USBCANDriver folder. Select *Include subfolders* option.

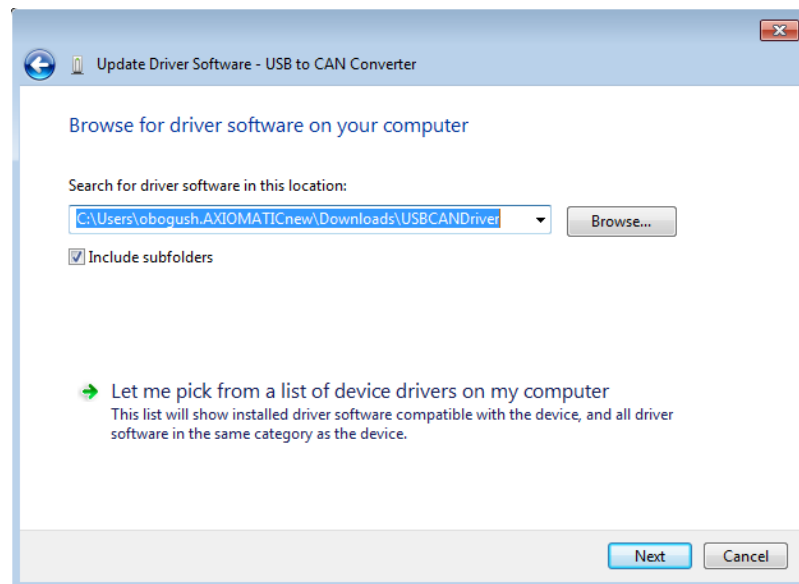

Figure 4-7. Driver Installation. Selecting the Driver Package

7. Press the *Next* button. *Windows Security* window will pop-up asking whether you like to install the device software from Axiomatic Technologies Corporation.

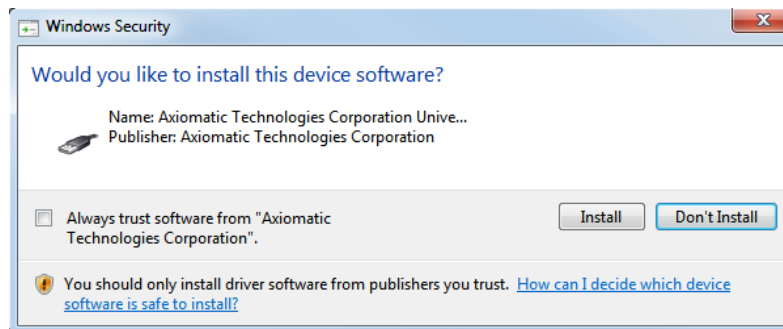

Figure 4-8. Driver Installation. Windows Security Window

8. Press the *Install* button. A pop-up window telling that Windows has finished installing the driver software should appear at the end of the installation process.

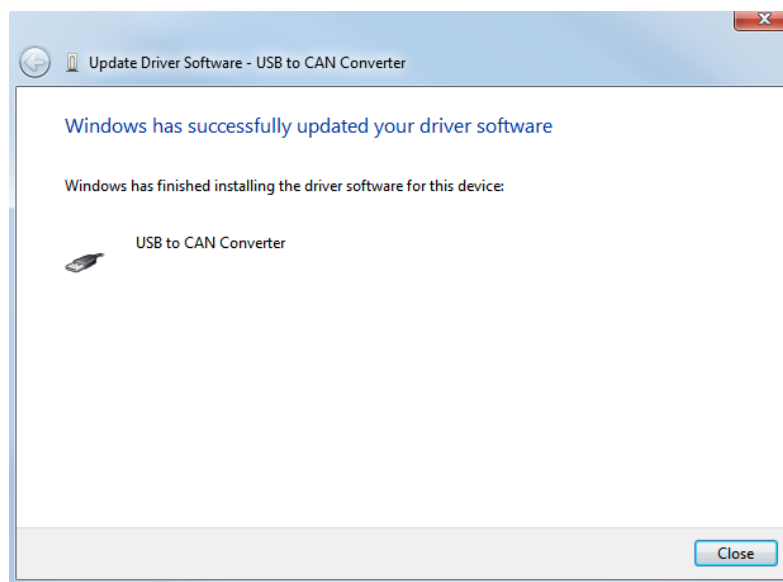



Figure 4-9. Driver Installation. Final Installation Window

9. Press the *Close* button. The *USB LED* on the front panel of the AX070501 converter or the *Status LED* on the front panel of the AX070505 converter should turn green. This means that the driver is successfully installed, and the converter is ready for use. You can now delete the temporary folder with the driver package files at ...*Downloads\USBCANDriver*.

4.4 Electronic Assistant

The newest version of the Electronic Assistant (EA) software can be downloaded from the *Electronic Assistant Downloads* section on the Axiomatic website, see Figure 4-3. It is marked *ElectronicAssistantSetup V<X.X.X.X>*, where: <X.X.X.X> field presents the EA version number.

After successful installation, the user will see the EA desktop icon  and the *Electronic Assistant <X.X.X.X>* program group in the *Start, All Programs* menu folder.

4.4.1 Electronic Assistant Hardware Support

By default, the EA works together with Axiomatic USB-CAN converters. It can also work with Axiomatic Ethernet-CAN and some other converters, see APPENDIX A.

To use a different converter, the user should go to *Options, CAN Interface Setup...* from the main menu. Then select the *Hardware Interface Module* from a drop-down list on the *CAN Interface Setup* dialog window with the hardware interface used by your converter.

For setting the individual configuration parameters of the selected hardware interface module refer to the user manual of your converter.

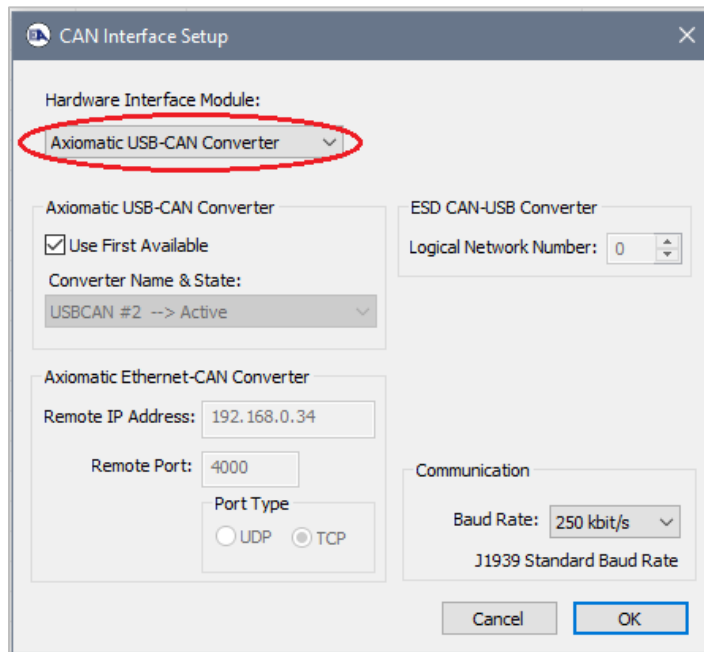

Figure 4-10. CAN Interface Setup Dialog. Setting Hardware Interface Module

4.5 Additional Software

In addition to the EA installation software and Axiomatic USB-CAN Converter drivers, the Electronic Assistant Downloads section on the Axiomatic website contains the following CAN bus monitoring software that can be downloaded and installed separately:

- CAN Assistant – Scope, part number: AX070501SCO,
- CAN Assistant – Visual, part number: AX070501VIS.

Users that are interested in writing their own applications for Axiomatic USB-CAN converters can download and install the USB-CAN Converter Software Development Kit (SDK), p/n: AX070501SDK.

For updating firmware in the USB-CAN converter, p/n AX070505, the user can download USB-CAN Converter Firmware Update Tool, p/n AX070505UT.

5 USING THE ELECTRONIC ASSISTANT

5.1 Hardware Requirements

The user should first set up a CAN network with termination resistors, connect the unit to the network and connect the CAN network to the PC running Electronic Assistant (EA) software through an Axiomatic USB-CAN Converter or other hardware interface module. The unit should be powered up. See OVERVIEW section for details.

5.2 Connecting to J1939 CAN

To connect the EA to a J1939 CAN bus, the user should select *Open CAN Port* from the *File* menu or select the leftmost *Open CAN Port* icon  from the toolbar.

Upon connecting to the bus, the EA will behave as any other Electronic Control Unit (ECU) on the bus and first will claim its address (Default 249, Off Board Diagnostic-Service Tool #1).



The EA is arbitrary address capable, so it will arbitrate if there is already another service tool on the bus using this address.

Immediately following the address claim, the EA will send out a request for *PGN 60928, Address Claimed Message*, and collect J1939 NAMEs of all ECUs on the CAN bus.

Then EA will identify and display ECUs with associated information and setpoint groups by using: *Industry Group, Vehicle System, Function, Function Instance, and Manufacturer Code* fields of their J1939 NAMEs.

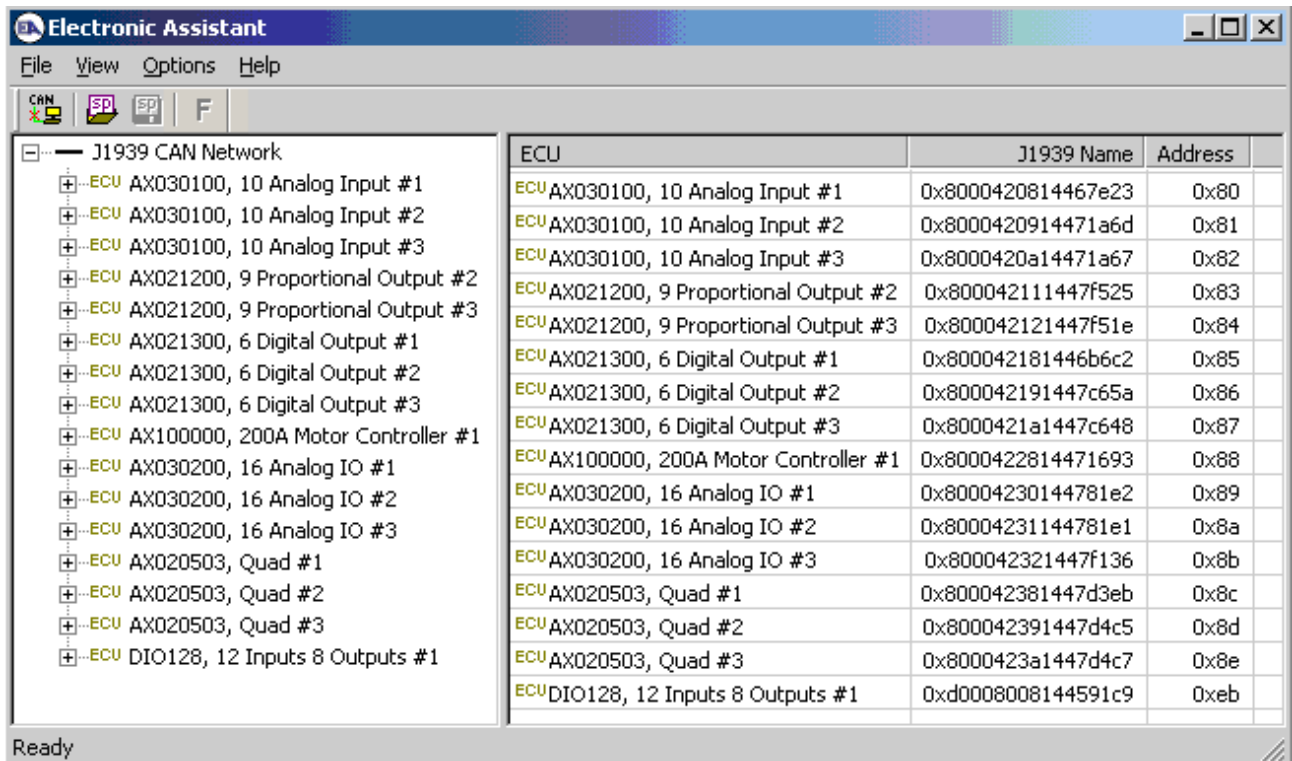

ECU	J1939 Name	Address
ECU AX030100, 10 Analog Input #1	0x8000420814467e23	0x80
ECU AX030100, 10 Analog Input #2	0x8000420914471a6d	0x81
ECU AX030100, 10 Analog Input #3	0x8000420a14471a67	0x82
ECU AX021200, 9 Proportional Output #2	0x800042111447f525	0x83
ECU AX021200, 9 Proportional Output #3	0x800042121447f51e	0x84
ECU AX021300, 6 Digital Output #1	0x800042181446b6c2	0x85
ECU AX021300, 6 Digital Output #2	0x800042191447c65a	0x86
ECU AX021300, 6 Digital Output #3	0x8000421a1447c648	0x87
ECU AX100000, 200A Motor Controller #1	0x8000422814471693	0x88
ECU AX030200, 16 Analog IO #1	0x80004230144781e2	0x89
ECU AX030200, 16 Analog IO #2	0x80004231144781e1	0x8a
ECU AX030200, 16 Analog IO #3	0x800042321447f136	0x8b
ECU AX020503, Quad #1	0x800042381447d3eb	0x8c
ECU AX020503, Quad #2	0x800042391447d4c5	0x8d
ECU AX020503, Quad #3	0x8000423a1447d4c7	0x8e
ECU DIO128, 12 Inputs 8 Outputs #1	0xd0008008144591c9	0xeb

Figure 5-1. List of ECUs on CAN J1939 Network

All unsupported ECUs will be displayed as *Unknown ECUs* with only *General ECU Information* group available on the ECU list in the left pane.

All ECUs will be numbered based on their *ECU Instance Number*.

The EA ECU will be visible on the ECU list as a *Virtual ECU*, if the user enables it through the *View* menu, *Show Virtual ECU*.

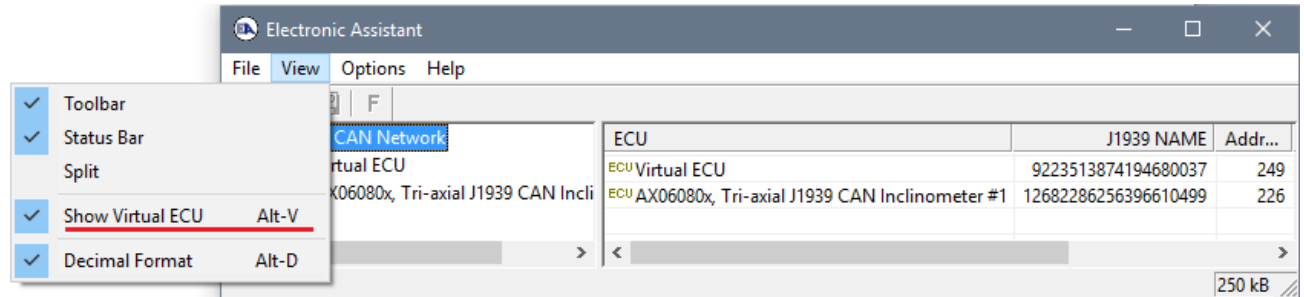

Figure 5-2. Virtual EA ECU

The *Virtual ECU*, presenting the EA, is hidden by default.

The user can change the numerical data presentation of EA parameters from *Hexadecimal* to *Decimal* format by using the *View* menu, *Decimal Format* option.

If the connection to the CAN bus was unsuccessful, or a hardware interface module other than the default *Axiomatic USB-CAN Converter* is used, the user should set up CAN interface parameters based on the hardware interface used by the converter, see APPENDIX A. The *CAN Interface Setup* dialog is available through the *Options* menu, *CAN Interface Setup*, or by double-clicking on the baud rate indicator on the right side of the status bar in EA versions 4.3.x.x and higher.

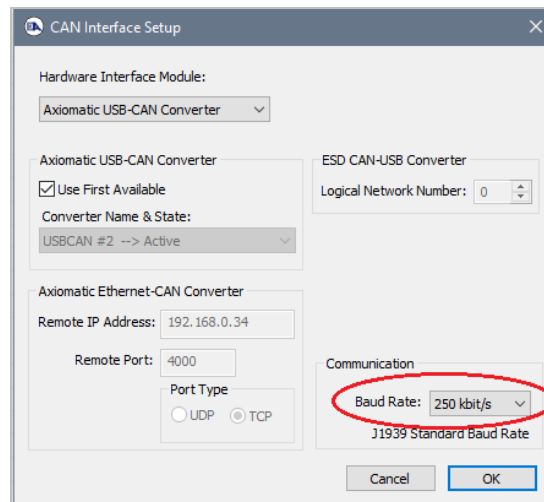

Figure 5-3. CAN Interface Setup Dialog. Baud Rate

From the *CAN Interface Setup* dialog window, the user can choose a hardware interface module, set up the module configuration parameters and, if the module allows it, change the CAN network baud rate.

For the *Axiomatic USB-CAN Converter*, the user can pick up an active converter from the *Converter Name & State* list if more than one converter is connected to the PC or keep the default *Use First Available* flag set when a single converter is used.

For the *ESD CAN-USB Converter*, the user should set the *Logical Network Number* assigned to the converter by its driver.

For the *Axiomatic Ethernet-CAN Converter*, the user sets *Remote IP Address*, *Remote Port*, and *Port Type* to establish IP connection with the *Axiomatic Ethernet-CAN Converter*.

The CAN baud rate can be changed through the drop-down *Baud Rate* menu for *Axiomatic USB-CAN Converter* and *ESD CAN-USB Converter*.



J1939 historically supported only 250 kbit/s baud rate on the CAN bus. J1939/14 standard added support for 500 kbit/s for compliant ECUs in 2011.

The user can change the baud rate from 250 kbit/s to 500 kbit/s or non-standard 667 kbit/s or 1Mbit/s in EA. This option is password protected to prevent from accidental use. The password is **ChangeBaudRate** (case sensitive).

When the CAN bus is running at a baud rate different from 250 kbit/s, the baud rate value is indicated in red in the EA status bar at the bottom-right corner of the EA window to warn the user of a potentially incompatible mode:

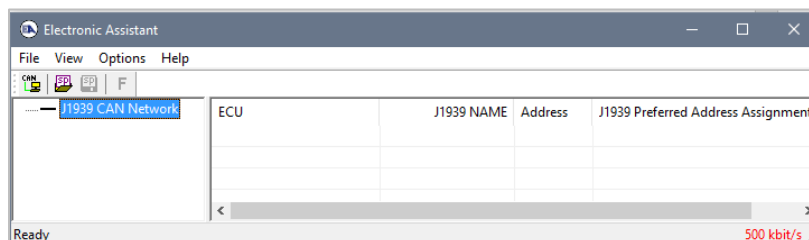

Figure 5-4. CAN bus running at 500 kbit/s baud rate



The baud rate is not selectable from EA for *Axiomatic Ethernet-CAN Converter*. The user can see and change the baud rate from the converter configuration website.

For the *Axiomatic Ethernet-CAN Converter*, the baud rate indicator in *CAN Interface Setup* dialog will be grayed. It will be also removed in the EA status bar at the bottom-right corner of the EA window.

5.3 General ECU Information Group

All ECUs on the J1939 CAN network will display the *General ECU Information* group. The group includes *ECU J1939 NAME* fields, *ECU Address* and, if available, *ECU ID* and *Software ID*.

Some old Axiomatic ECUs have their *Identity Number* field in the *ECU J1939 NAME* calculated on the base of the ECU serial number. For those ECUs, the EA will perform a reverse calculation and show the 8-digit part of the ECU serial number in the description part of the *Identity Number* field.

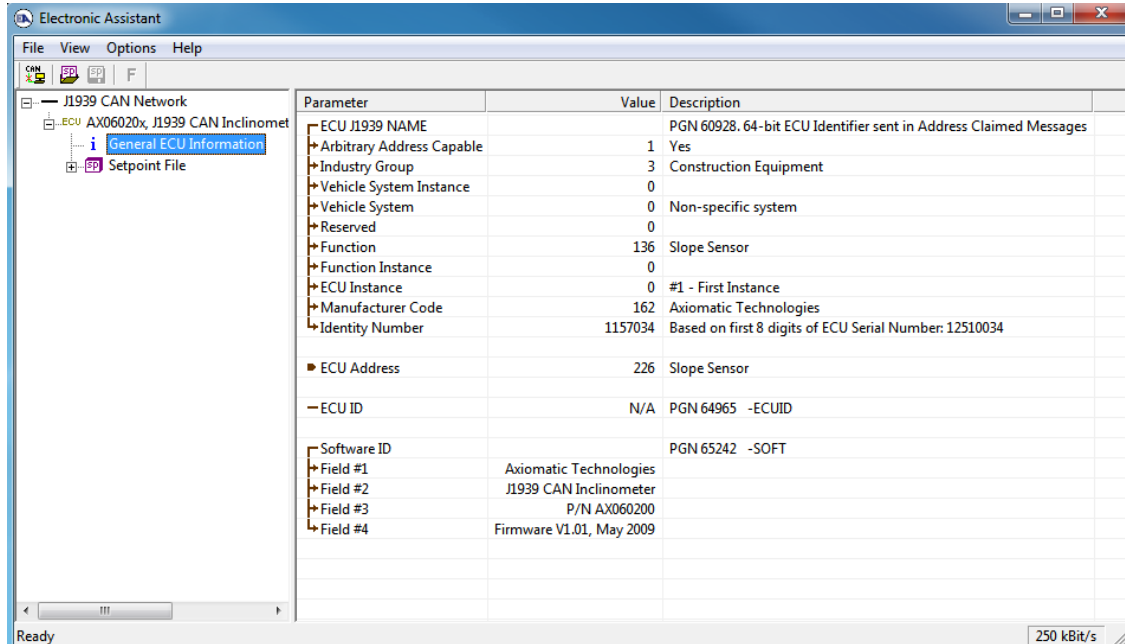

Figure 5-5. General ECU Information

New releases of Axiomatic ECUs do not use this type of calculations. The *ECU Part Number* and *ECU Serial Number* fields are now displayed independently in the *General ECU Information* group pane.

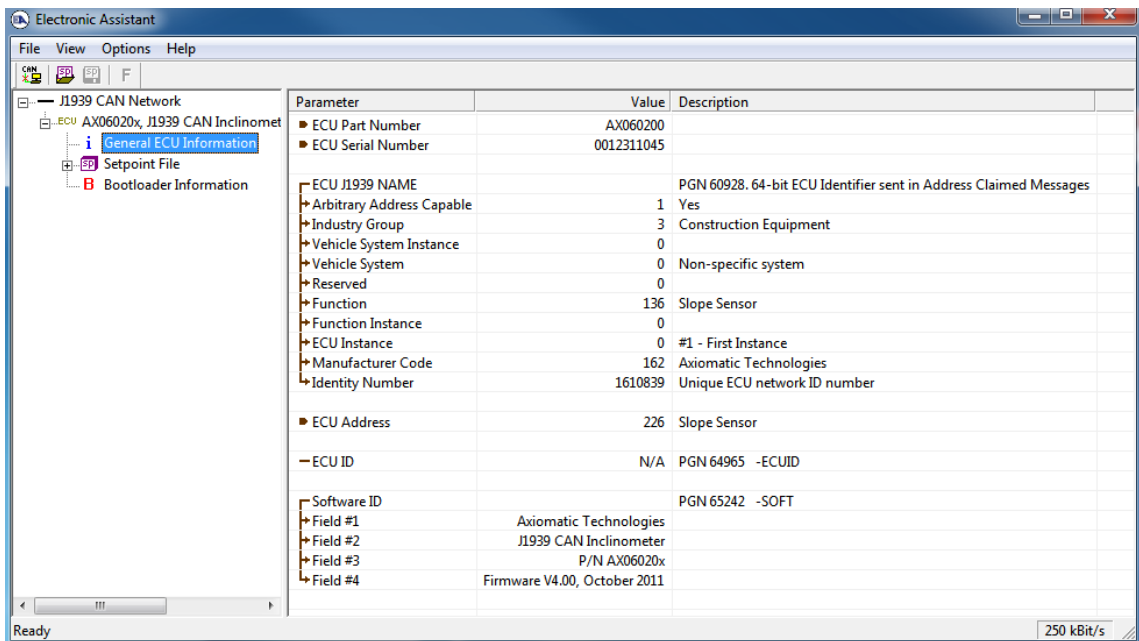

Figure 5-6. General ECU Information (New)

5.4 Reading Configuration Parameters

All ECU configuration parameters (setpoints) are located in the *Setpoint File* top-level group. This group contains one or several application-level setpoint groups.

Each setpoint group has its own unique name and contains a set of configuration parameters. Typically, a setpoint group will contain a set of configuration parameters controlling a certain piece of hardware (input or output) or a function (for example, *Conversion Function* or a *CAN Input Signal*).

When a setpoint group is selected, a list of all configuration parameters of the group and their values (as read from the ECU) is displayed in the right pane of EA.

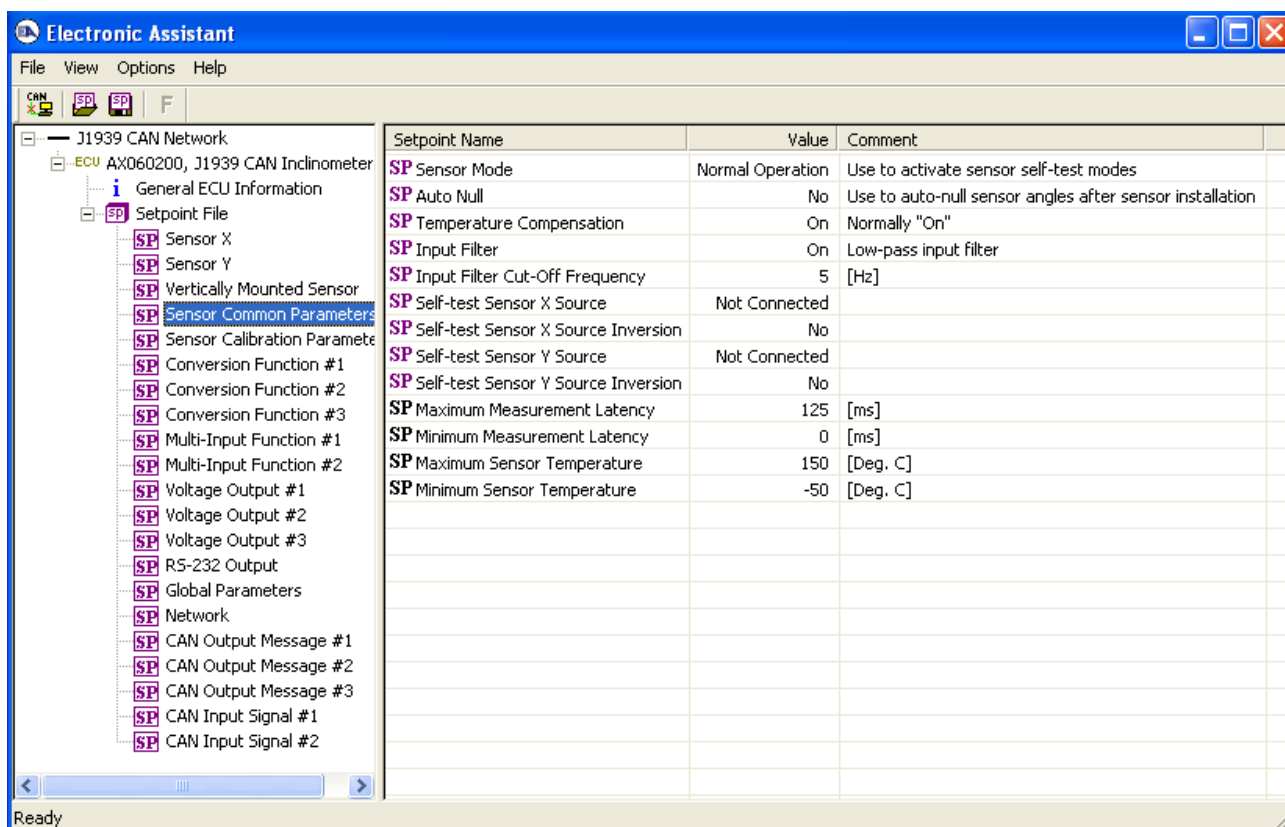

Figure 5-7. Setpoint Group

5.5 Editing Configuration Parameters

To change a configuration parameter, the user should double-click on it. The editing pop-up dialog window will appear. The user then can enter a new value or select it from the list.

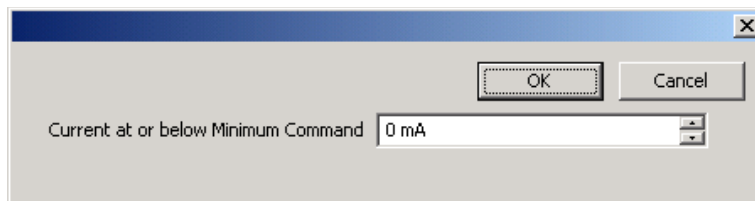

Figure 5-8. Configuration Parameter Editing Dialog Windows (Example 1)

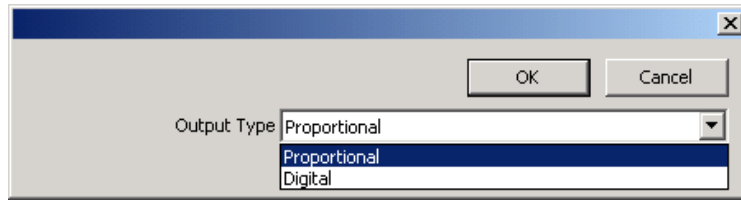

Figure 5-9. Configuration Parameter Editing Dialog Windows (Example 2)

Once the user selects OK to close the pop-up window, the EA will write the new value to the ECU.

If the entered value is outside of the allowable range for that configuration parameter, the EA will inform the user, and default back to the last valid value that was entered.

Then writing to the ECU memory takes some time, an hourglass will appear and an animated message in the left corner of the status bar will inform the user that the operation is running.

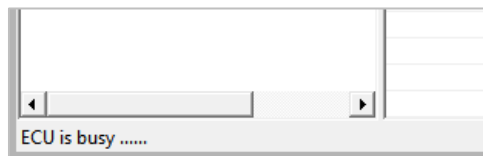

Figure 5-10. ECU is Busy Writing a New Configuration Parameter

The ECU will save the new configuration parameter in non-volatile memory and will immediately start using it.

The type of the editing dialog window will depend on the type of the configuration parameter and the ECU. For some configuration parameters, a password will be asked before the EA shows the editing dialog.

Configuration parameters with black icons **SP** are read-only and cannot be changed.

Configuration parameter reading and writing operations are implemented using the Memory Access Protocol (MAP), as defined in the J1939-71 standard. All non-standard configuration parameters (which are typically the majority of ECU configuration parameters, except the *ECU Instance Number* and the *ECU Address*) use proprietary MAP addresses.

5.6 Multiple ECU Instances

The EA can configure up to 8 units of the same type on the CAN bus using the *ECU Instance Number* configuration parameter. This configuration parameter is typically a part of the *Miscellaneous*, *Network* or *J1939 Network* setpoint group in the *Setpoint File*.

The user should select the required ECU instance number from the list of available instance numbers in the *ECU Instance Number Setup* dialog window and then press *OK* button or double-click the selected instance number.

In the *Comment* column of the ECU instance number list, the user can see whether the instance is already taken by an ECU of the same type on the network. The current ECU instance will be marked as “<-- This ECU”.

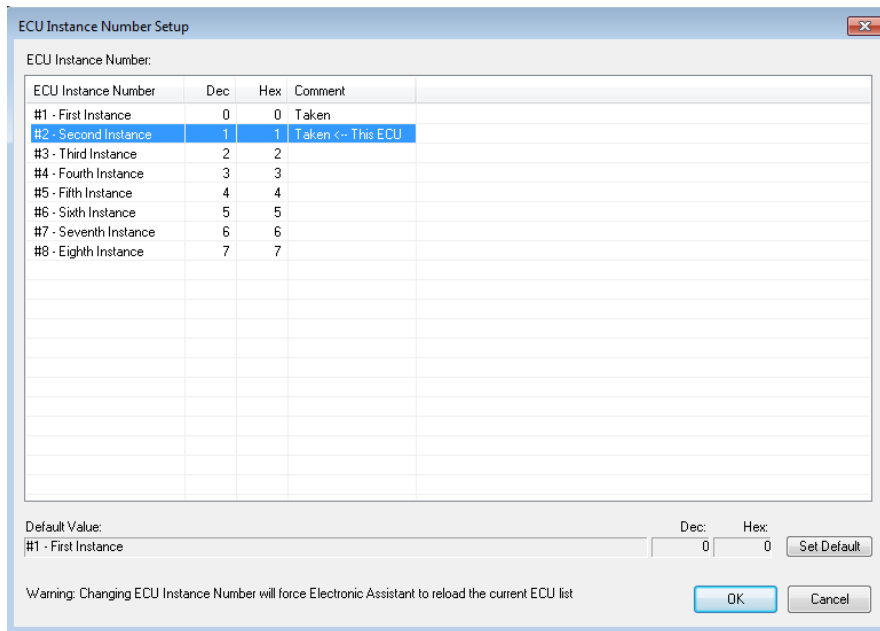

Figure 5-11. ECU Instance Number Setup Dialog

Changing the *ECU Instance Number* will force the EA to reload the current ECU list.

5.7 Changing ECU Address

The user can change the ECU address, if necessary, using the *ECU Address* configuration parameter located normally together with the *ECU Instance Number* in the *Miscellaneous, Network* or *J1939 Network* setpoint group in the *Setpoint File*.

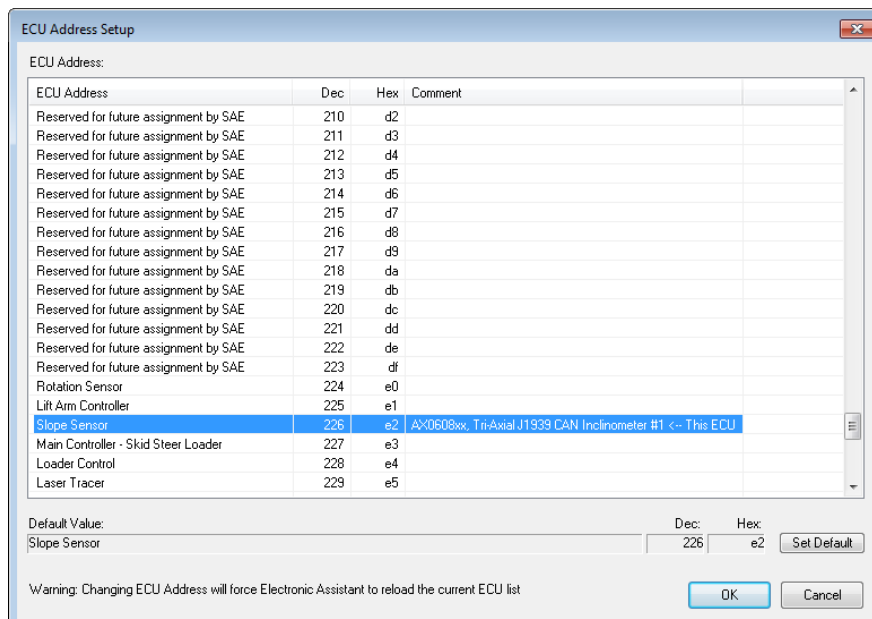



Figure 5-12. ECU Address Setup Dialog

Similar to the *ECU Instance Number*, the user should select the required *ECU Address* from the list of available *ECU Addresses* in the *ECU Address Setup* dialog window and then press *OK* button or double-click the selected ECU address.

In the *ECU Address* column of the list, the user can see the J1939 address assignment for a given address and in the *Comment* column – an ECU that currently occupies that address. The current ECU address will be marked as “<-- This ECU” in the *Comment* column.

Changing the *ECU Address* will force the EA to reload the current ECU list.



Selecting an already taken address is possible, but it will result in an address arbitration process that, depending on the ECU NAME field value, will either allow the ECU to occupy the new address or will move the ECU to a free address reserved for dynamic address assignments.

5.8 Saving Configuration Parameters in Setpoint File

The user can save all configuration parameters of a selected ECU in a setpoint file on disk. Also, the configuration parameters can be flashed back to the ECU from a setpoint file.

To save configuration parameters, the user selects: *Save Setpoints* or *Save Setpoints As...* from the *File* menu and follows the prompt. Alternatively, the user can click on the *Save Setpoint File* toolbar icon .

The configuration parameters will be first read from the ECU and then written, together with the ECU identification information, to the selected setpoint file. A progress bar will show the state of the reading operation.

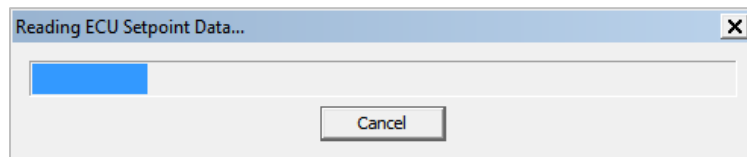

Figure 5-13. Configuration Parameter Reading Progress Bar

In case of errors, the user will be prompted to redo operation for the unread configuration parameters.

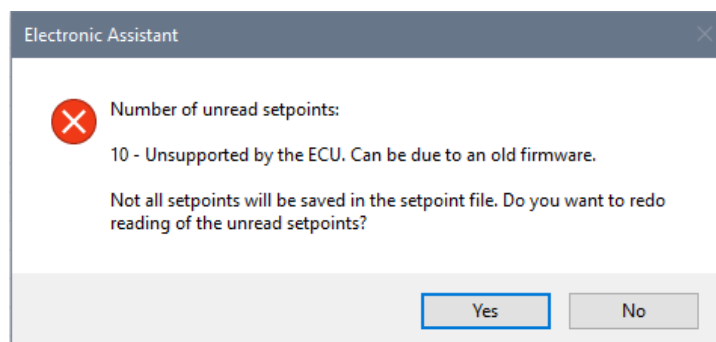



Figure 5-14. Error During Reading of the Configuration Parameter

After reading, the configuration parameters will be saved in the setpoint file on disk in XML format. The user will be prompted if erasing of the already existing setpoint file can occur during this operation.

A text file (with *.txt* extension) is also generated in the same directory as the XML file if *Generate Setpoint Text File* option is set in the main menu (*Options, Generate Setpoint Text File*). This file contains the same information as the setpoint XML file, but in a plain text format without XML tags.

In the past, when the setpoint XML files did not have a readable “pretty-print” format, some customers were using the text files together with the setpoint XML files. Now, this option is obsolete and kept only for the backward compatibility with the older EA versions.

5.9 Reading Configuration Parameters from Setpoint File

The setpoint file with configuration parameters can be opened by clicking on the *Open Setpoint File* toolbar icon  or from the *File* menu, by selecting the *Open Setpoint File...* item. The *Setpoint File Viewer* dialog window will open as shown below.



A setpoint file can be opened from disk even if the EA is not connected to the CAN bus and the *CAN port* is closed.

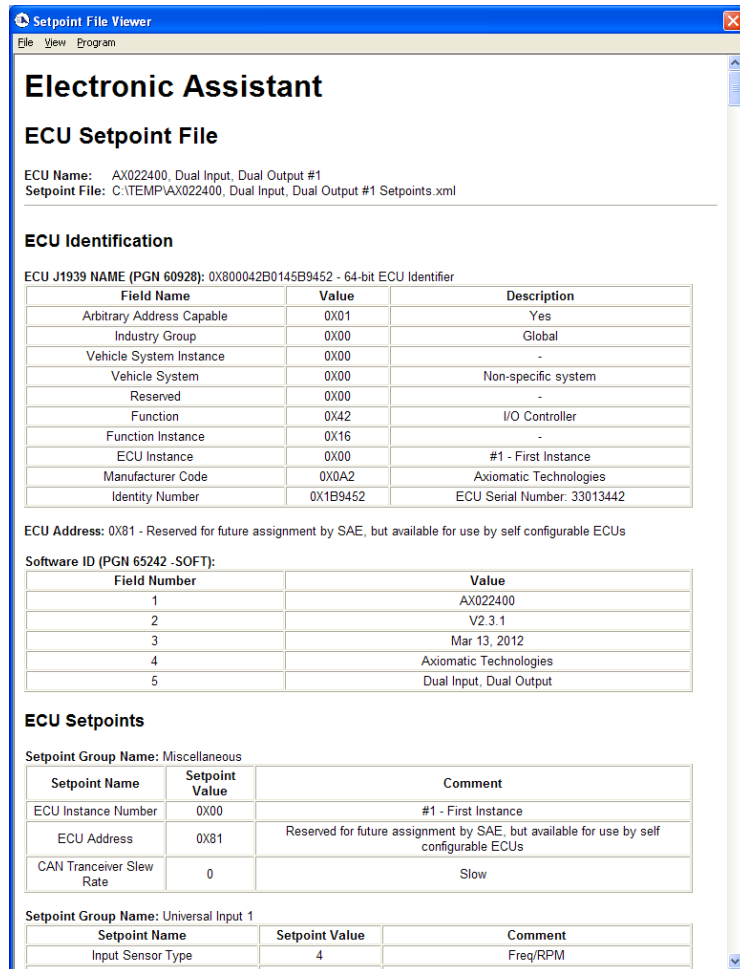

Figure 5-15. Setpoint File

5.10 Programming Configuration Parameters from Setpoint File

To program configuration parameters from a setpoint file to a unit, the user should first select the unit from the list of ECUs on the CAN bus, click on the selected ECU *Setpoint File* group in the left pane and then open the required setpoint file from the disk.

Then the user can program the ECU with configuration parameters from the setpoint file in the *Setpoint File Viewer* dialog window by selecting the *Program Setpoints into ECU* item from the *Program* menu.



If the selected ECU has different identification information from the one in the setpoint file, the programming operation will not be available, and the *Program Setpoints into ECU* menu item will be grayed. This item will be also grayed if the user has not selected the *Setpoint File* group before opening the setpoint file.

The EA shows a progress bar while programming the unit with the new configuration parameters from the setpoint file. The programming time mostly depends on the number of configuration parameters with the new values that should be reprogrammed.

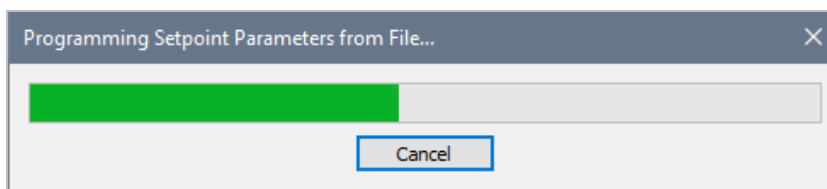

Figure 5-16. Programming Progress Bar for Configuration Parameters



Some of the configuration parameters are not programmable from the file. They include read-only and network configuration parameters, such as *ECU Instance* and *ECU Address*.

In some cases, other configuration parameters may not be programmable from the setpoint file but can be programmable on the individual basis from the setpoint group pane – please refer to the ECU's User Manual.

At the end of the programming process, the EA shows the result of the programming operation. If some of the configuration parameters have not been programmed, the user can try to program them again.

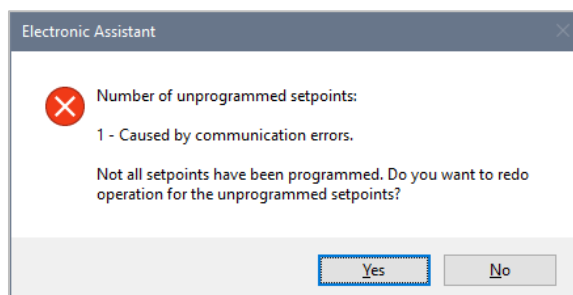

Figure 5-17. Error During Programming of the Configuration Parameters

If all configuration parameters have been programmed successfully, the following message will appear.

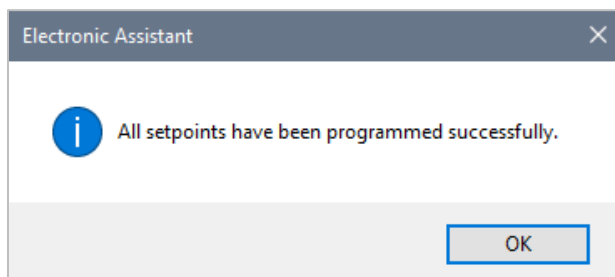

Figure 5-18. Successful Programming of the Configuration Parameters

5.11 Comparing ECU Configuration Parameters with Setpoint File

The ECU configuration parameters can be compared with the setpoint file in the *Setpoint File Viewer* dialog window by selecting the *Compare Programmable Setpoints* item from the *Compare* menu. Only ECU programmable configuration parameters will be compared.

The user can double check the result of the programming operation using this command. This is extremely helpful when the EA is remotely connected to the ECU over the internet.

The configuration parameters are first read from the ECU the same way as in the Saving Configuration Parameters operation. The user can redo reading in case of errors. Then the ECU programmable configuration parameters are compared with the configuration parameters from the file. The result is displayed to the user.

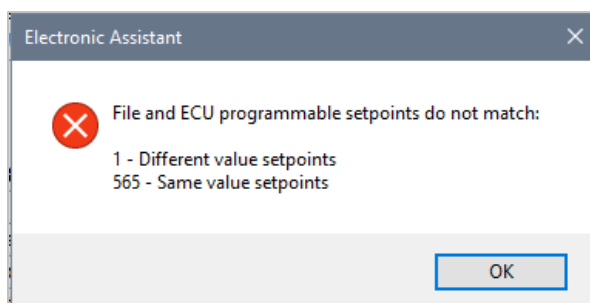

Figure 5-19. ECU Configuration Parameters do not match the Setpoint File

In case the configuration parameters are the same, the following message is displayed.

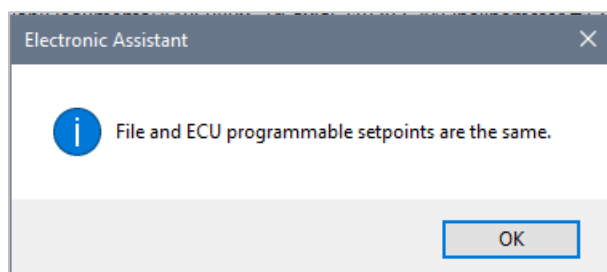

Figure 5-20. ECU Configuration Parameters match the Setpoint File

5.12 J1939 Bootloader

Most Axiomatic controls come with the embedded J1939 Bootloader. This bootloader allows users to update application firmware in the field without disconnecting the units from the user's system.

The bootloader also provides users with extended information about the unit hardware, installed bootloader and application firmware. The J1939 Bootloader support was added in EA starting from V4.0.35.0.

When a unit has the bootloader support, the EA will show the *Bootloader Information* group in the ECU left pane below the *General ECU Information* and *Setpoint File* groups. When the *Bootloader Information* group is selected, it shows the information pane describing the unit hardware, bootloader, and application firmware.

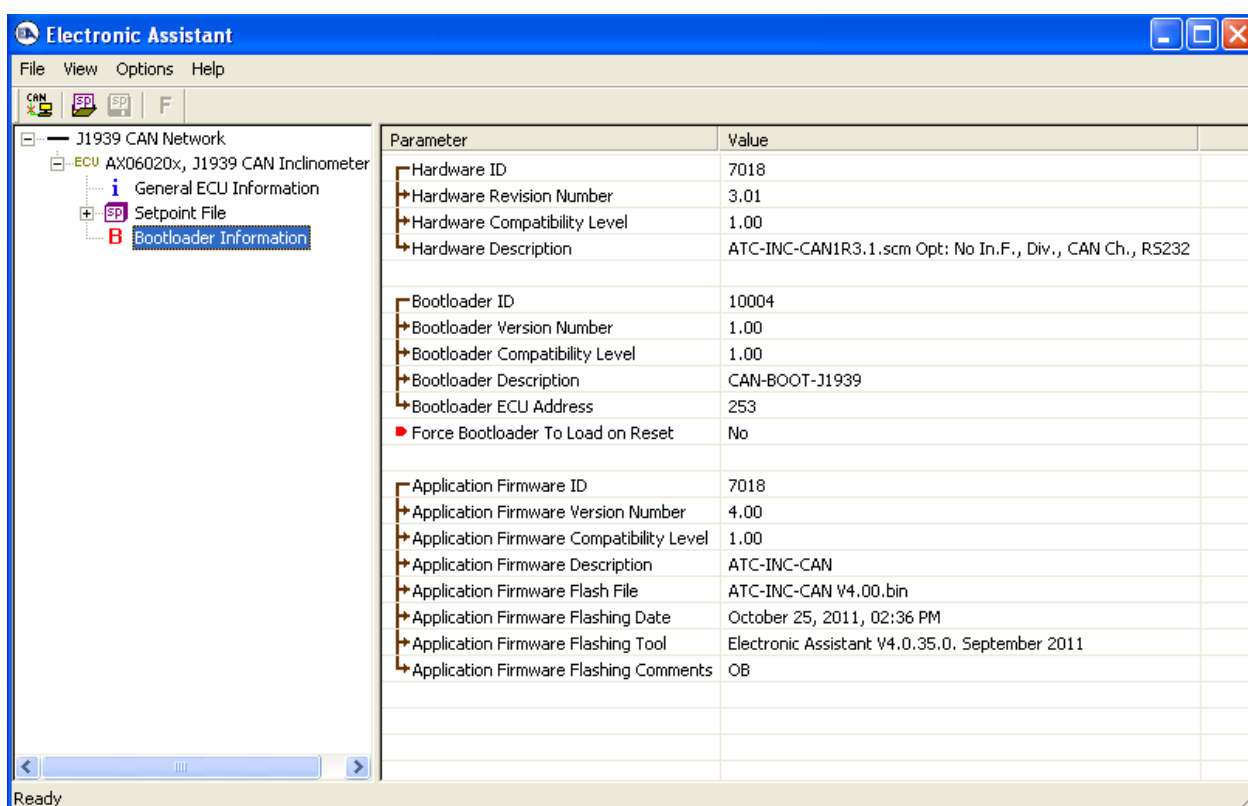

Figure 5-21. Bootloader Information (ECU supports J1939 Bootloader)

In the *Bootloader Information* group pane, the user can see a *Force Bootloader to Load on Reset* flag. The user can change this flag to Yes to activate the embedded bootloader.

After reset, the embedded bootloader will appear on the network as a regular ECU at the *Bootloader ECU Address*. The user should check this address first, before activating the bootloader, to ensure that there are no address conflicts since the *J1939 Bootloader* ECU is not capable to dynamically relocate its ECU address.

Upon reset, the user will see the following *Bootloader Information* group pane in the *J1939 Bootloader* ECU.

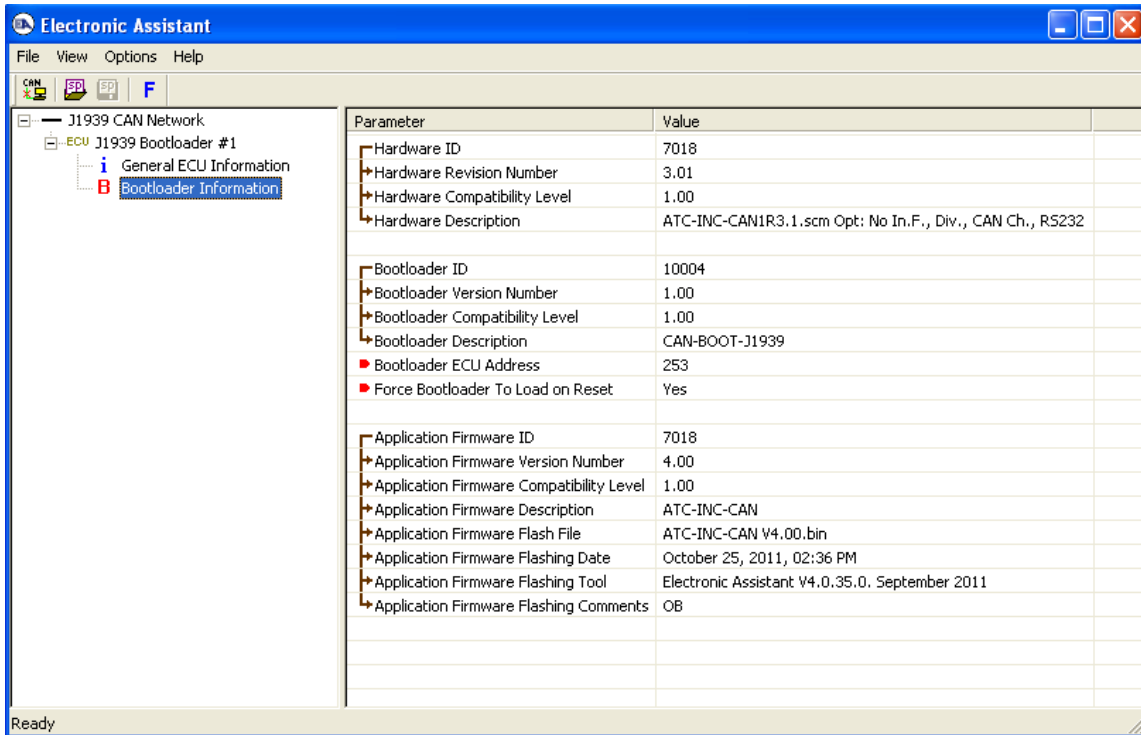

Figure 5-22. Bootloader Information (Bootloader)

This group pane shows the same information as the *Bootloader Information* group pane when the unit is running the application firmware. The only difference is that now, for extra flexibility, the user can change the *Bootloader ECU Address*. The *ECU Part Number* and *ECU Serial Number* in the *General ECU Information* group pane also remain the same.

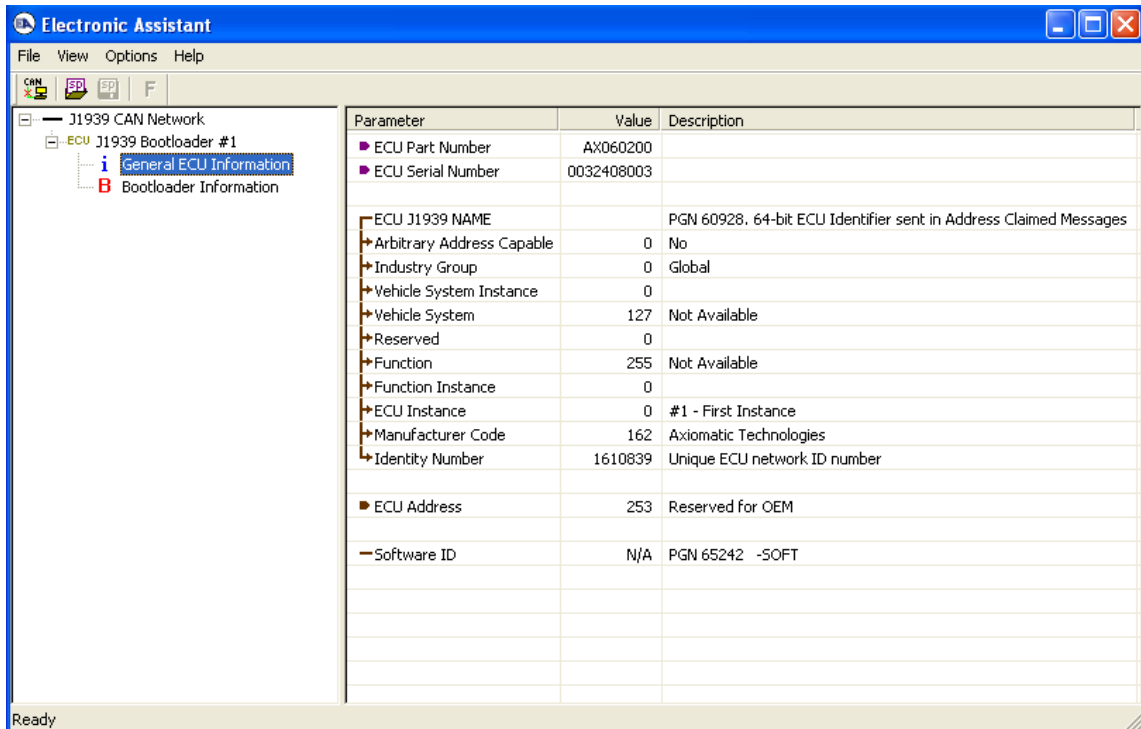

Figure 5-23. General ECU Information (Bootloader)

The user can now return back to the application firmware, by setting the *Force Bootloader to Load on Reset* flag back to *No* and resetting the ECU or flash a new application firmware into the unit.

5.13 Flashing New Application Firmware

The user can flash the new application firmware if the unit has an embedded *J1939 Bootloader*. Units with the embedded bootloader will have the *Bootloader Information* group in the ECU left pane. Flashing the new firmware is performed when the embedded *J1939 Bootloader* controls the unit.

To flash the new application firmware, the user should first activate the *J1939 Bootloader* by setting the *Force Bootloader to Load on Reset* flag in the *Bootloader Information* group pane to *Yes*.

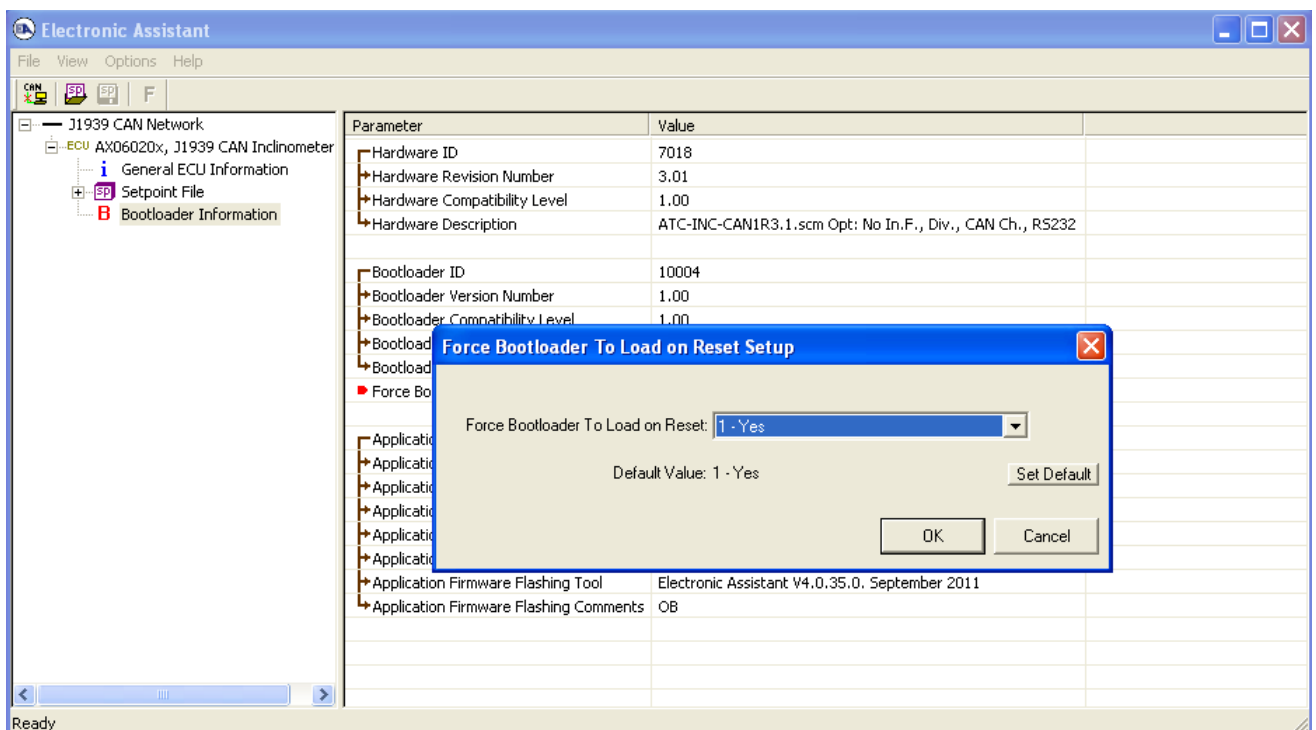

Figure 5-24. Bootloader Activation

This will activate the bootloader on the next ECU reset. The user can force the ECU to perform the reset without cycling the power by answering *Yes* to the next dialog prompt that will appear right after changing the *Force Bootloader to Load on Reset* flag.

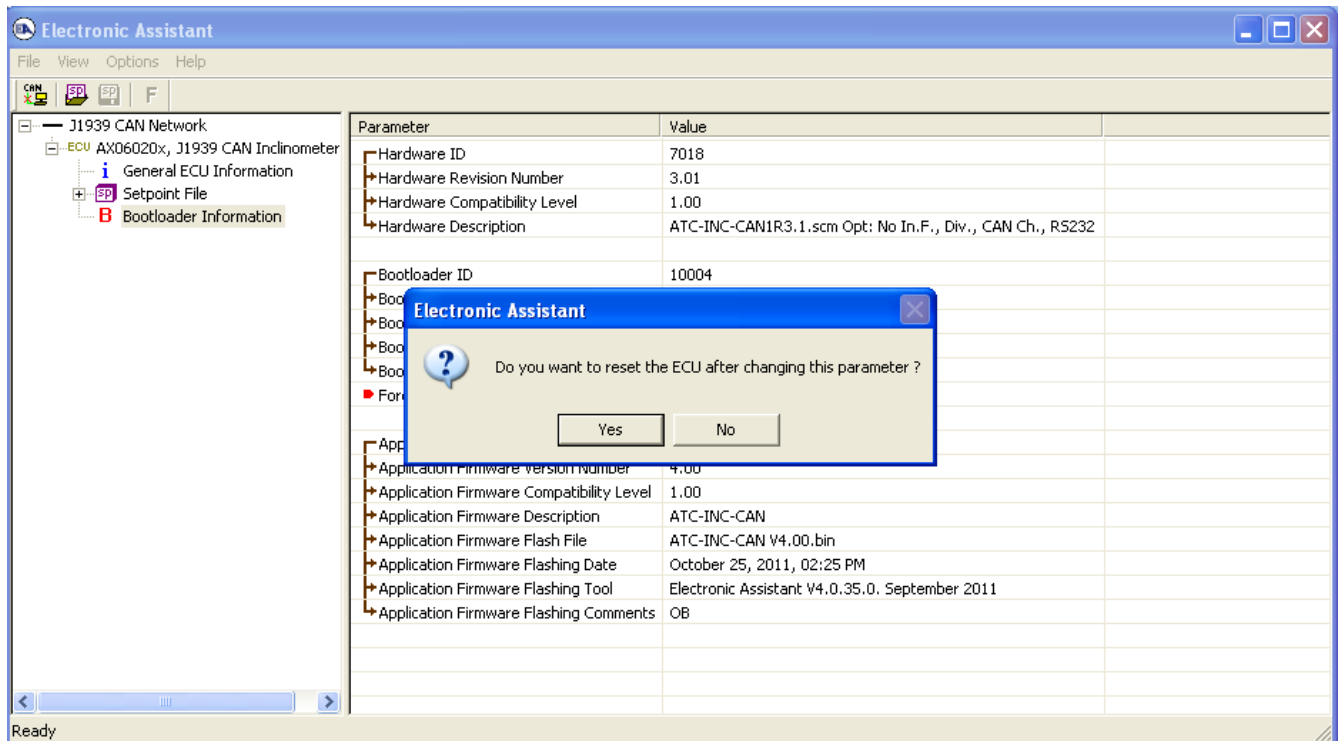

Figure 5-25. Resetting the ECU

After reset, the user will see a *J1939 Bootloader ECU* instead of the original ECU. This means that the embedded *J1939 Bootloader* controls the unit.

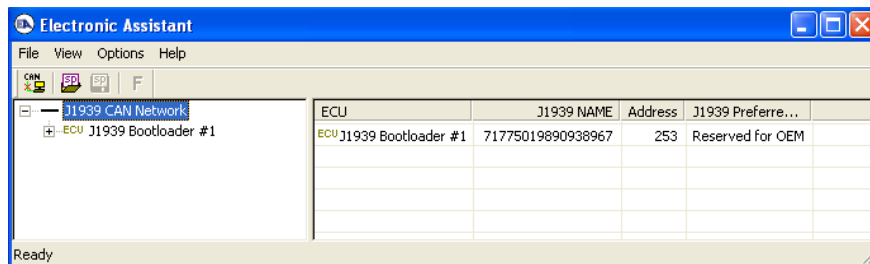

Figure 5-26. J1939 Bootloader Controls the ECU

Then, in the *J1939 Bootloader ECU*, the user should select *Bootloader Information* group from the left pane and open an application firmware flash file by clicking on the *Open Flash File* toolbar icon **F** or from the *File* menu selecting the *Open Flash File...* item. The *Open Application Firmware Flash File...* dialog window will appear.

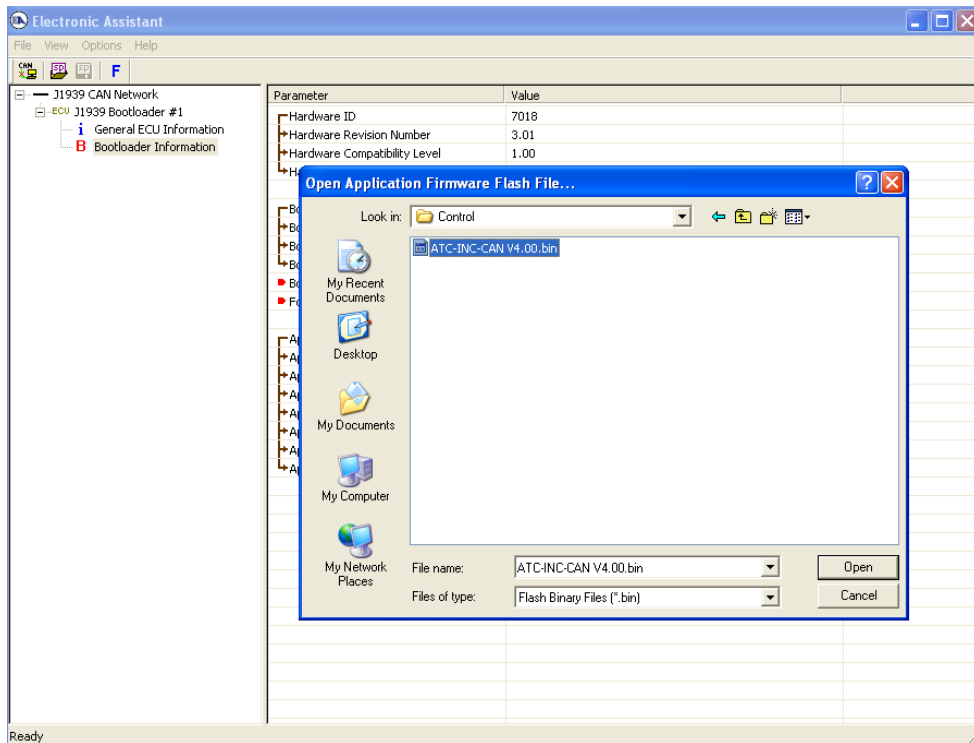

Figure 5-27. Selecting the Application Firmware Flash File

When the flash file is selected, the user will see the *Flash Application Firmware* dialog window. In this example, an old firmware is being re-flashed.

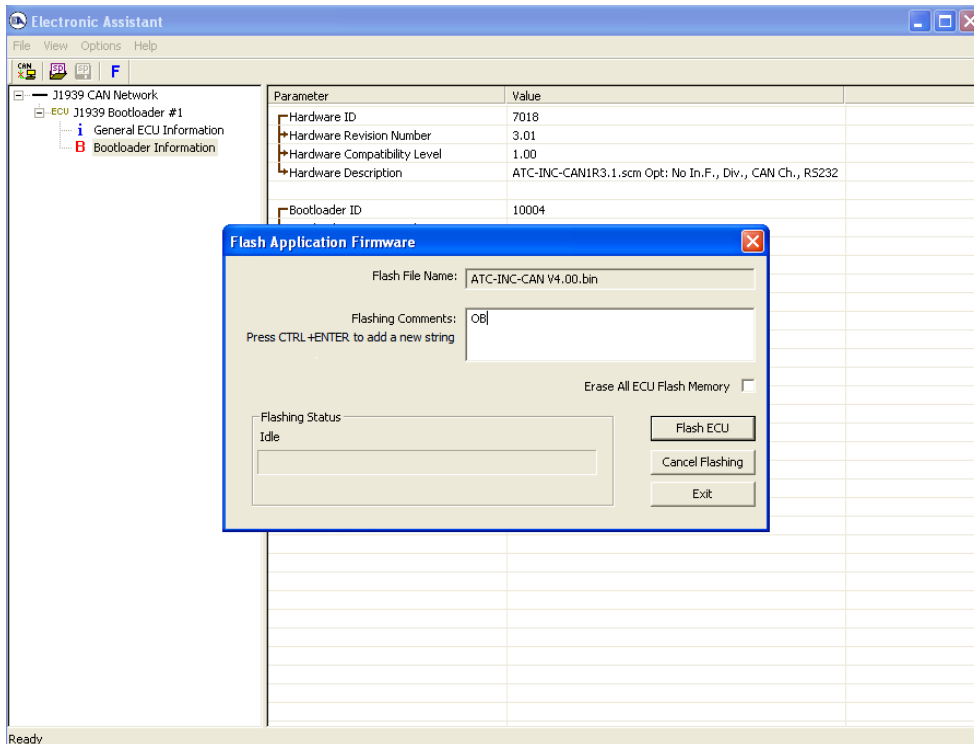

Figure 5-28. Flash Application Firmware Dialog Window

In this window, the user can add flashing comments. They will appear in the *Bootloader Information* group pane of the unit when flashing is successfully done. The user can also select here the *Erase All ECU Flash Memory* option to wipe off all configuration parameters and other settings left by the old application firmware.

To start the ECU flashing operation, the user should press the *Flash ECU* button. A warning message will appear telling the user that the operation will erase the old application firmware.

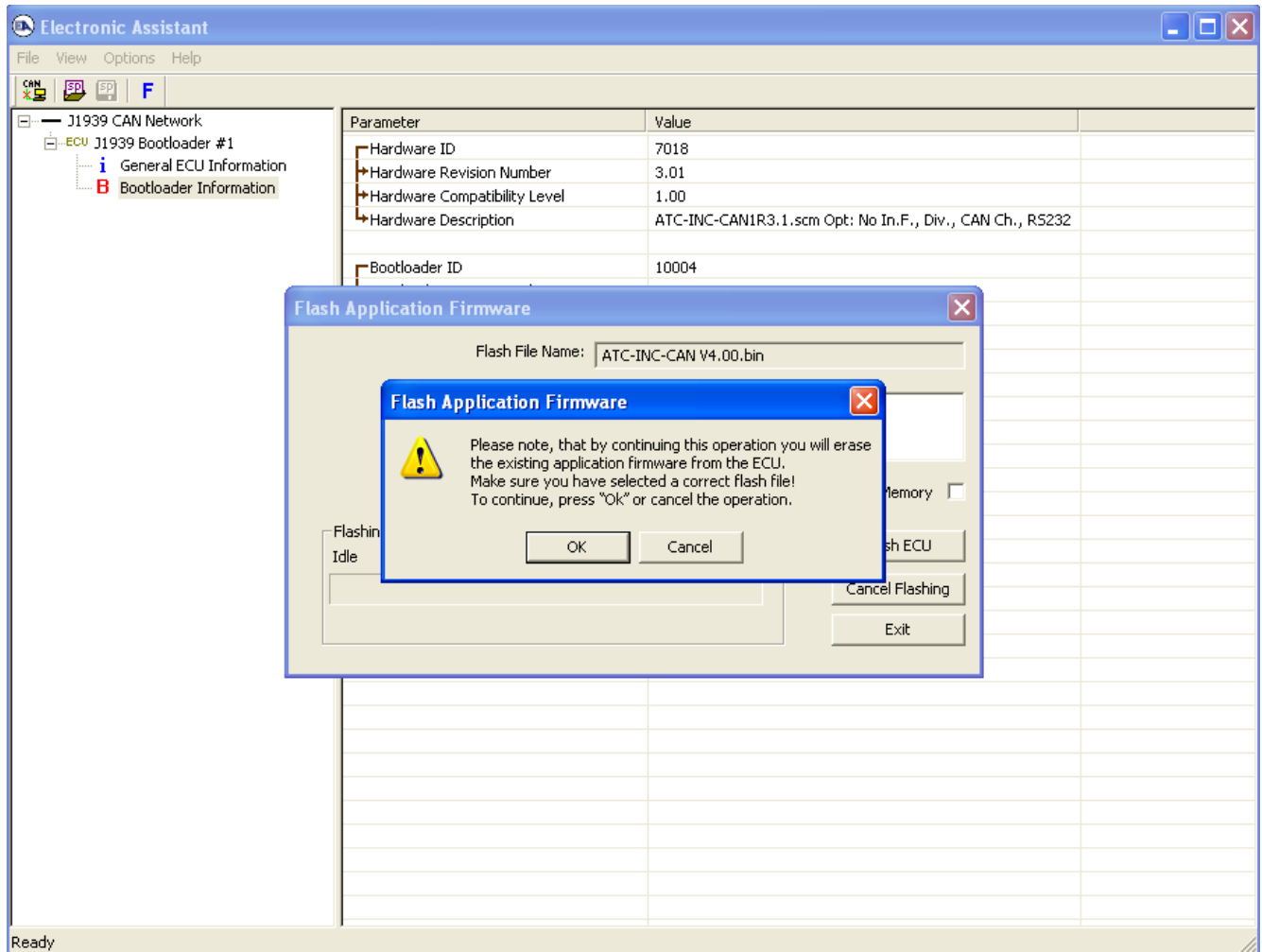

Figure 5-29. Warning Message Before Firmware Flashing



The flashing command is irreversible. Once started, it will destroy the old application firmware. It is important to have a correct version of the flash file for the particular unit before starting flashing.

If the flashing operation fails for any reason, the unit will remain in the active bootloader mode showing the *J1939 Bootloader* ECU in EA and flashing can be repeated.

When the flashing operation is started, a flashing status message and a progress bar will show the dynamics of the operation in the *Flashing Status* part of the dialog window. The *Flashing Comments* and *Erase All ECU Flash Memory* fields will be grayed to prevent the user from altering them when the flashing process is running.

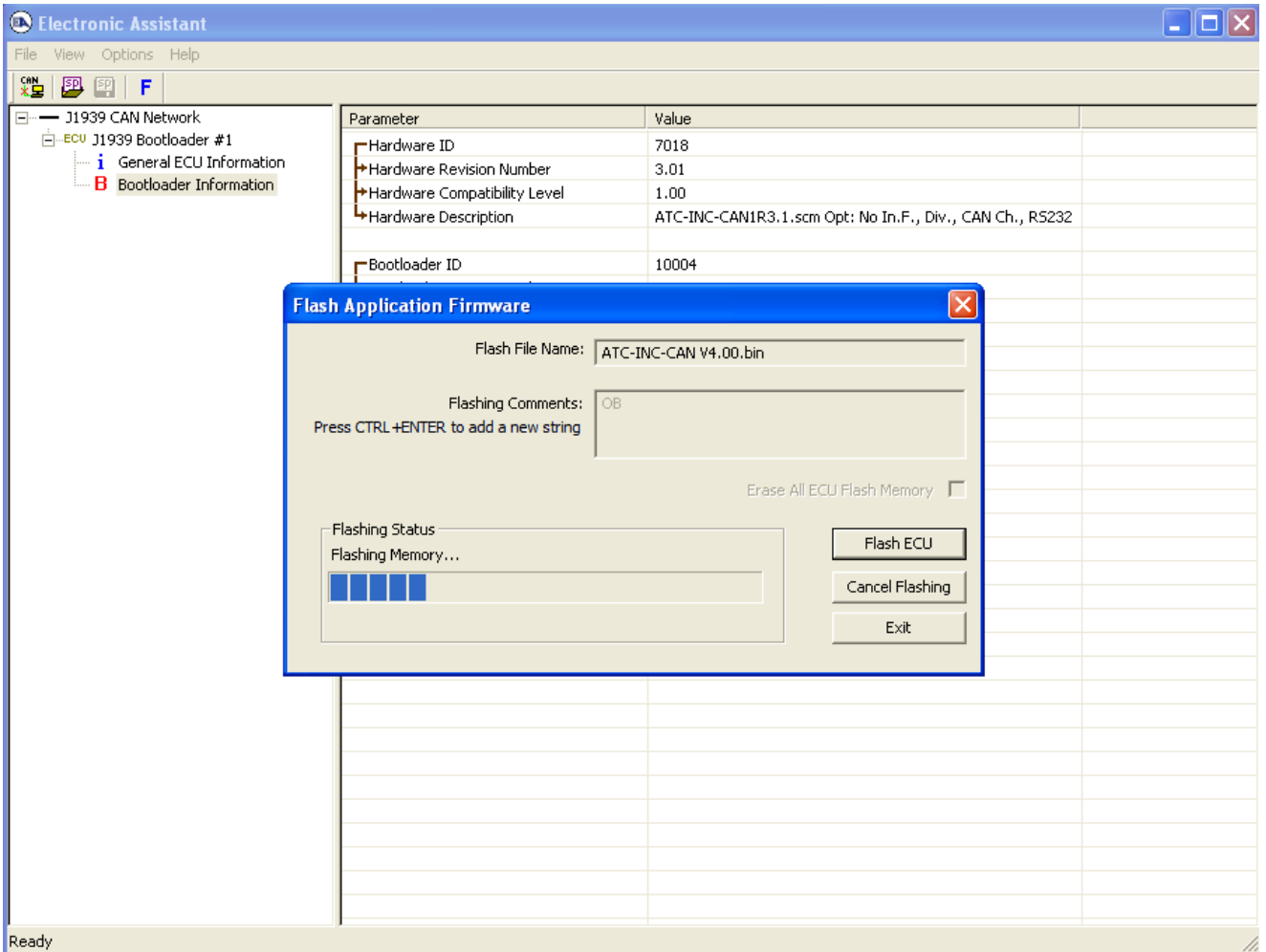

Figure 5-30. Flashing Operation is Running

When a flashing command takes more time than expected, an hourglass and “ECU is busy ...” animated message will appear under the progress bar.

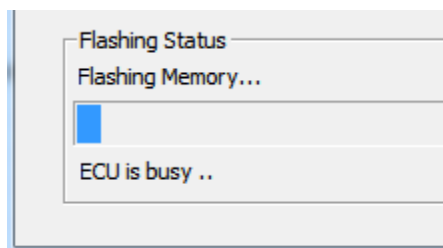

Figure 5-31. ECU is Busy During Flashing Operation

In case of an error during the flashing operation, it will be displayed under the progress bar as well.

At the end of flashing, the user will be prompted to reset the ECU as the final step of the flashing operation.

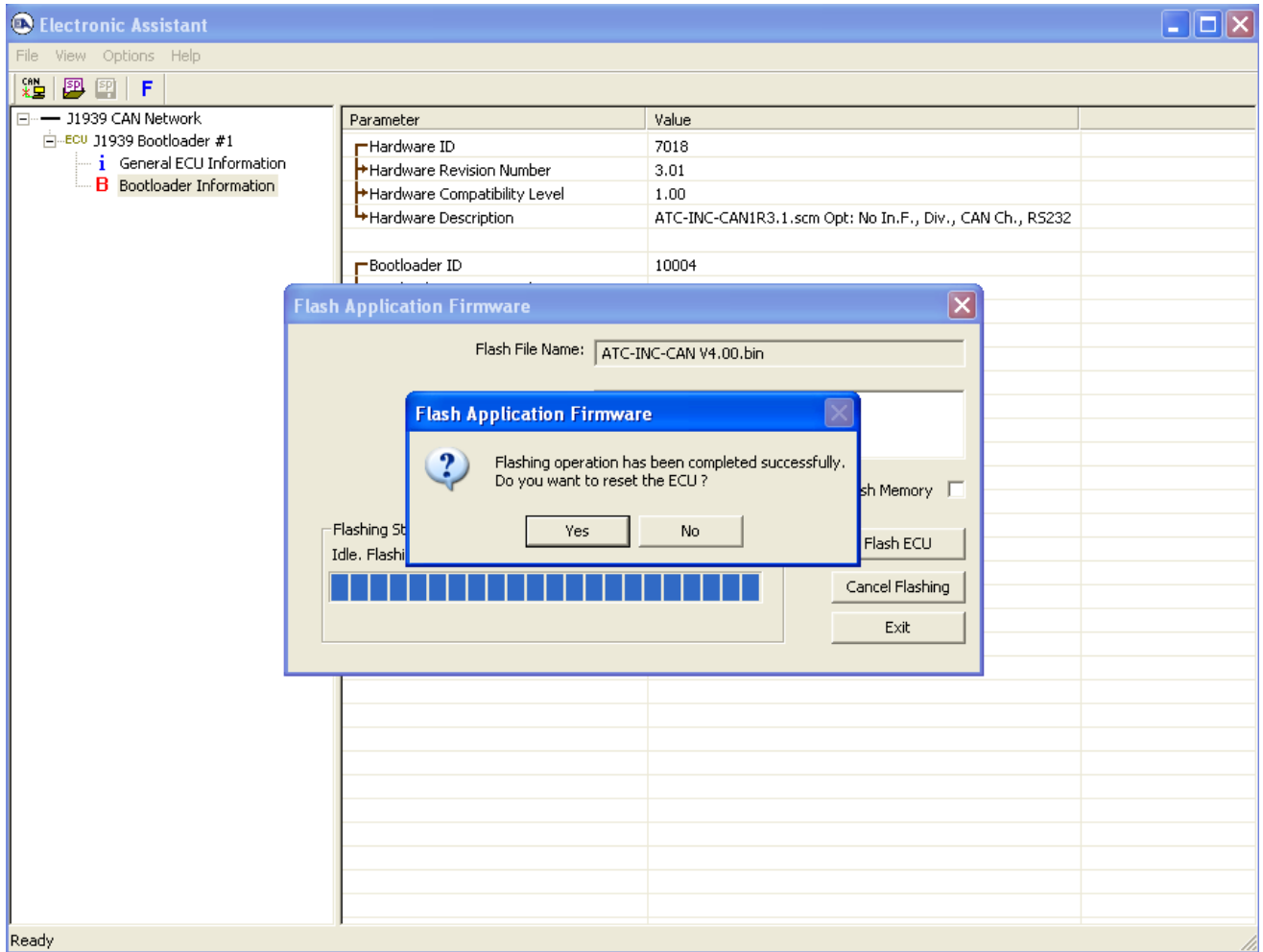

Figure 5-32. Flashing Operation has been Completed Successfully

Upon reset, the unit will be running the new application firmware.

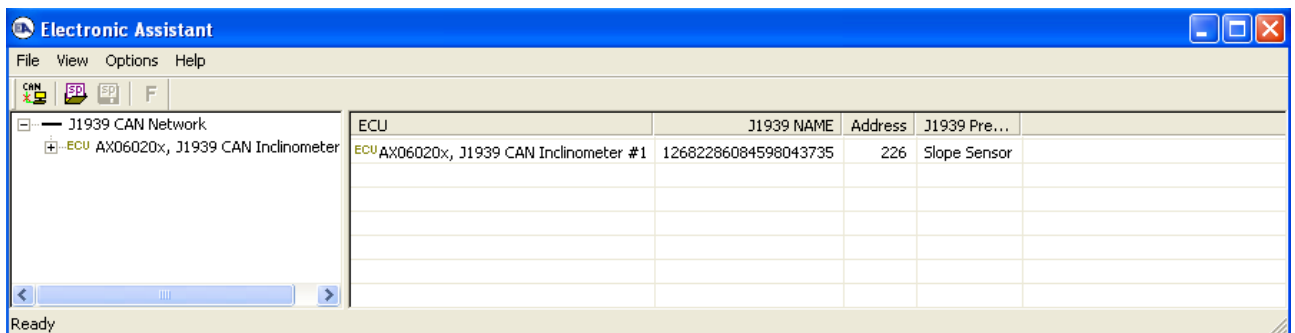

Figure 5-33. Unit is Running the New Application Firmware

List of Supported Hardware Converters

Manufacturer	P/N	Description	Hardware Interface	Remark
Axiomatic	AX070501	Axiomatic USB-CAN Converter	Axiomatic USB-CAN Converter	Default converter. Needs a driver
	AX070505			
	AX140900	Axiomatic Ethernet-CAN Converter	Does not need a driver	
	AX140901	Ethernet-CAN Converter		
ESD	C.2064.02	USB-CAN-Mini	ESD CAN-USB Converter	Needs a driver

7 APPENDIX B

List of Supported Axiomatic ECUs

The EA supports the following Axiomatic units:

Axiomatic Part Number	Description
AX020200	Dual Output Valve Controller with CAN
AX020400	12 Inputs, 12 Outputs Valve Controller
AX020410	12 Inputs, 12 Outputs Valve Controller
AX020507	Valve Controller, Quad with +5Vref, 50mA
AX020510	Valve Controller, 6 Inputs, 5 Outputs
AX020512	6 Inputs, 5 Outputs Valve Controller
AX020520	6 Inputs, 5 Outputs Valve Controller
AX020530	7 Inputs, 5 Outputs Valve Controller
AX021100	2.5A Connector Amplifier with CAN
AX021200	Valve Controller, 9 Proportional Output
AX021210	10 Output Valve Controller
AX021210-01	10 Output Valve Controller (500kbit/s)
AX021210-02	10 Output Valve Controller (1 Mbit/s)
AX021213	10 Output Valve Controller, PCB Assembly
AX021300	Valve Controller, 6 Digital Output
AX021600	Universal Input, 2A Output
AX021610	Single Input Single Valve Output Controller
AX021800	Dual Valve Controller, 4 - Universal Inputs, 2 - 3A Outputs
AX021810	Dual Valve Controller, 4 - Universal Inputs, 2 - 3A Outputs, Without Voltage References
AX021900	Valve Controller, 8 Inputs, 5 Outputs
AX022000	Dual Output CAN Controller, 1-Universal Input, 2 - 3A Outputs
AX022003	Universal Input, Dual Valve Output CAN Controller
AX022200	Single Valve Controller
AX022002	CAN with Dual 3A Outputs, Top Connect
AX022020	CAN with Dual 3A Outputs, Side Connect
AX022310	CAN with Dual 2.5A Outputs, Plug-In
AX022400	Dual Input, Dual Output, Top Connect
AX022410	Dual Input, Dual Output, Side Connect
AX022420	Four Inputs, Two Outputs Universal Valve Controller
AX022440	Two Bipolar Inputs, Two Universal Inputs, Two Proportional Outputs Controller
AX022460	Two Bipolar Inputs, Four Pulse Valve Outputs Controller
AX022800	Positional Valve Driver
AX022950	7 Digital Inputs, 6 Digital Outputs, 4 LED Outputs Controller
AX023210	Fan Drive Controller
AX023220	2 Input, Dual Valve Controller, High Temperature
AX023220-01	2 Input, Dual Valve Controller, High Temperature (500 kbit/s)
AX023220-02	2 Input, Dual Valve Controller, High Temperature (1 Mbit/s)
AX023240	Quadrature Decoder Input, Dual Valve Controller, High Temperature, SAE J1939
AX023300	2 Inputs, 2 Outputs Valve Controller
AX023302	A061D644, 2 Inputs, 2 Outputs Controller

Axiomatic Part Number	Description
AX024000	Servo Controller
AX024010	DIN Rail Servo Controller
AX029000	10-Output Valve Ethernet Driver
AX030100	10 Analog Input
AX030120	10 Universal Signal Input CAN Controller
AX030120-01	10 Universal Signal Input CAN Controller (500 kbit/s)
AX030120-02	10 Universal Signal Input CAN Controller (1 Mbit/s)
AX030130	10 Universal Signal Input with 5V Reference Output
AX030130-01	10 Universal Signal Input with 5V Reference Output, 500kbit/s
AX030130-02	10 Universal Signal Input with 5V Reference Output, 1Mbit/s
AX030140	3 Encoder, 7 Signal Inputs Controller, CAN Isolated
AX030160	8 Digital Input to CAN Controller
AX030200	16 Analog I/O
AX030210	12 Input, 8 Signal Output & 1 Relay Output Controller
AX030210-01	12 Input, 8 Signal Output & 1 Relay Output Controller, 500kbit/s
AX030210-02	12 Input, 8 Signal Output & 1 Relay Output Controller, 1Mbit/s
AX030300	18 Digital Input
AX030310	18 Digital Input to CAN Controller
AX030320	18 Digital Input to CAN Controller
AX030440	4 Universal Inputs, 5V/8V Voltage Reference, CAN Controller
AX030500	4 Analog Signal Output CAN Controller
AX030520	1 Analog Signal Output CAN Controller
AX030530	1 Analog Signal Input CAN Controller
AX030540	CAN to 4 Analog Outputs Controller
AX030550	Isolated Dual CAN to Sine or Square Output
AX030570	1 Resistive Output CAN Controller
AX030600	6 Universal Signal Input Controller, SAE J1939, Ethernet
AX031200	Multi-Function I/O Module 48-pin
AX031500	Magnetic Pick-up Input with CAN
AX031700	Single Input Controller with CAN
AX031702	Fuel Sensor Input to CAN Controller
AX031705	Single Input Controller with CAN
AX031800	Twelve Digital Inputs, Eight Discrete Outputs Controller
AX031800-01	Twelve Digital Inputs, Eight Discrete Outputs Controller, 500kbit/s
AX031800-02	Twelve Digital Inputs, Eight Discrete Outputs Controller, 1Mbit/s
AX031850	Twelve Digital Inputs, Eight Discrete Outputs, Cinch Connector
AX031850-01	Twelve Digital Inputs, Eight Discrete Outputs, Cinch Connector, 500kbit/s
AX031850-02	Twelve Digital Inputs, Eight Discrete Outputs, Cinch Connector, 1Mbit/s
AX031901	Single Digital Input to Dual NC Relay Outputs
AX031950	Bipolar Input, Relay Output and Analog Output with NFC
AX032000	18-Cell Battery Monitoring System
AX032050	16-Cell Battery Monitoring System
AX032100	2 Bipolar, 8 Universal Signal Input Controller, CAN, Ethernet, 2x5V Ref, DIN
AX032200	1 Digital Input, 2 Digital Outputs Controller
AX060201	Inclinometer, SAE J1939, Two M12 Connectors, Both CAN
AX060201D	Inclinometer, SAE J1939, Two M12 Connectors, Both CAN, Sealing for Underwater Applications

Axiomatic Part Number	Description
AX060202	Inclinometer, SAE J1939, Two M12 Connectors, CAN, 3 Analog Outputs
AX060203	Inclinometer, SAE J1939, Two M12 Connectors, CAN, RS-232
AX060400	Inclinometer, SAE J1939, Single Deutsch DT15-4P Connector, Power and CAN
AX060401	Inclinometer, SAE J1939, Single Deutsch DT15-4P Connector with CAN Termination
AX060700	Tri-Axial J1939 CAN Inclinometer with Gyro. Two M12 Connectors, Both CAN
AX060700-01	Tri-Axial J1939 CAN Inclinometer with Gyro. Two M12 Connectors, Both CAN, 500 kbit/s
AX060701	Tri-Axial J1939 CAN Inclinometer with Gyro. Two M12 Connectors, CAN, 4 Analog Outputs
AX060702	Tri-Axial J1939 CAN Inclinometer with Gyro. Two M12 Connectors, CAN, RS-232
AX060800	Tri-Axial J1939 CAN Inclinometer – Two M12 Connectors, Both CAN
AX060804	Tri-Axial J1939 CAN Inclinometer – One M12 Connector
AX060806	Tri-Axial J1939 CAN Inclinometer – One Deutsch DT15-4P Connector
AX060807	Tri-Axial J1939 CAN Inclinometer – One Deutsch DT15-4P Connector with CAN Termination
AX060808	Tri-Axial J1939 CAN Inclinometer – Vertical Mount, Two M12 Connectors, Both CAN
AX060810	Tri-Axial J1939 CAN Inclinometer – One DT15-4P Connector
AX060811	Tri-Axial J1939 CAN Inclinometer – One DT15-4P Connector, CAN Termination
AX060830	Tri-Axial J1939 CAN Inclinometer – Two M12 Connectors, Both CAN
AX060838	Tri-Axial J1939 CAN Inclinometer – Vertical Mount, Two M12 Connectors, Both CAN
AX060900	Tri-Axial Gyro Inclinometer, SAE J1939
AX060910	Tri-Axial Gyro Inclinometer with Extended Dynamic Range, SAE J1939
AX061000	Tri-Axial J1939 CAN Inclinometer with Analog Outputs
AX062008	Tri-Axial Inclinometer with Single-Axis Gyro, Vertical Mount, SAE J1939
AX062018	Tri-Axial Inclinometer with Single-Axis Gyro, Extended Dynamic Range, Vertical Mount, SAE J1939
AXDIO128	Discrete I/O Module, 12 Inputs, 8 Outputs
AXDIO128-03	12 Digital Input, 8 Relay Output Controller
AXTC4	Four Thermocouple Scanner
AXTC20	Twenty Thermocouple Scanner
AXRTD8	Eight RTD Scanner
AX090000	12V Generic Battery Charger
AX090001	24V Generic Battery Charger
AX090003	24V Generic Battery Charger
AX090004	12V Generic Battery Charger
AX090300	5A Solar Charger for 12V Battery
AX090550	12VDC Battery Charger
AX090560	12/24VDC Battery Charger 15A
AX090600	24VDC to 14VDC 2A Battery Charger
AX100000	150A Motor Controller with I/O (Brushed DC, 12V/24VDC)
AX100050	150A Motor Speed Controller (Brushed DC, 12V/24VDC)
AX100100	Generic 25A DC Motor Controller
AX100200	BLDC Motor Drive (12V/24VDC, 25A)
AX100240	50W BLDC Controller
AX100250	BLDC Motor Drive (12V/24/48VDC, 40A)

Axiomatic Part Number	Description
AX100260	6A 100W BLDC Controller
AX100265	6A 100W BLDC Controller
AX100270	BLDC and 2 DC Motor Controller
AX100280	100W 48V BLDC Controller
AX100286	600W 48V BLDC Controller
AX100310	Universal 25A DC Motor Controller
AX100600	5A Motor Controller
AX100700	2A Stepper Motor Drive
AX100750	Dual Stepper Motor Drive, 2A, CAN (SAE J1939), 2 AIN, 2 FIN, UOUT, Encoder
AX102000	35A Bidirectional DC Motor Controller
AX102100	40A Bidirectional DC Motor Controller
AX104001	Throttle Valve Controller
AX105000	150A Bi-directional DC Motor Controller
AX130500	Dual Input, Dual Output Signal Controller
AX130510	2 Inputs, 2 Outputs Isolated Signal Converter
AX130520	2 Inputs, 2 Outputs Signal Converter
AX130522	2 Inputs, 2 Outputs Isolated Signal Converter
AX130540	2 Inputs, 2 Outputs Isolated Signal Converter
AX130550	4 AC Inputs to 4 Analog Outputs Controller
AX130601	J1772 Compliant Wake on Charge Module
AX130700	CAN to PWM Output Controller
AX130750	CAN to 1 Relay and 2 Analog Outputs Converter
AX130750-01	CAN to 1 Relay and 2 Analog Outputs Converter, 500kbit/s
AX130750-02	CAN to 1 Relay and 2 Analog Outputs Converter, 1Mbit/s
AX130770	CAN to 1 Relay and 2 Analog Outputs Converter
AX130770-01	CAN to 1 Relay and 2 Analog Outputs Converter, 500kbit/s
AX130770-02	CAN to 1 Relay and 2 Analog Outputs Converter, 1Mbit/s
AX140100	J1939-J1939-ModbusRTU Converter
AX140100-100	J1939-J1939-ModbusRTU Converter
AX140170	Isolated J1939-J1939-ModbusRTU Converter
AX140200	J1939-CANopen-ModbusRTU Converter
AX140201	J1939, CANopen, J1587 Converter
AX140202	J1939-CANopen-ModbusRTU
AX140320	J1939-J1939-ModbusRTU Converter
AX140321	J1939-CANopen-ModbusRTU Converter
AX140322	J1939-J1939-J1587 Converter
AX140400	J1939, J1939, J1587 Converter
AX140401	J1939, J1939, J1587 Converter
AX140402	J1939, CANopen, J1587 Converter
AX140403	J1939, CANopen, J1587 Converter
AX140405	J1939-CANopen-ModbusRTU
AX140406	J1939, J1939, J1587 Converter
AX140510	PLC to J1939 Protocol Converter
AX140600	LIN - J1939 CAN Converter
AX140600-01	LIN - J1939 CAN Converter (500kbit/s)
AX140600-03	LIN - J1939 CAN Converter
AX140601	LIN - J1939 CAN Converter

Axiomatic Part Number	Description
AX140602	LIN - J1939 CAN Converter
AX140920	BPS Master Module
AX141100	CAN-Bluetooth Converter and Datalogger
AX141120	1 Universal Input, Dual CAN RTC Controller
AX141150	CAN-Bluetooth Converter
AX141810	RS485-Ethernet-CAN Converter
AX141830	RS485-Ethernet-CAN Converter
AX142100	Protocol Converter
AX180010	7 Universal Inputs, 3 RTD, 2 Universal Outputs Controller
AX180400	Laser Receiver
AX180800	20 Thermocouple, 2 RTD, 4 Inputs, 6 Relays Dual CAN Controller
AX181000	4 TC, 7 Analog, 3 Universal Inputs
AX184000	12 RTD, 4 Universal Inputs
AX185000	Twenty Channel Thermocouple Scanner
AX185000-01	Twenty Channel Thermocouple Scanner, 500kbit/s
AX185000-02	Twenty Channel Thermocouple Scanner, 1Mbit/s
AX186000	Six Channel Thermocouple Scanner
AX188000	Two Channel Thermocouple Scanner
AX189000	Thermocouple, 2 Universal Input Dual CAN Controller
AX200000	4 Channel Strain Gauge Controller
AX200100	12-Channel Strain Gauge with TARE Controller
AX200102	12-Channel Strain Gauge Controller
AX200300	4 Channel Strain Gauge, Open Wire Detection, CAN Controller

Refer to each listed unit *Technical Datasheet* for a detailed description and ratings of the product.

Refer to each listed unit *User Manual* for more information about each configuration parameter and how changing it will affect the performance of the unit.

The user can retrieve the list of supported units from the main menu by selecting: *Help, About Electronic Assistant...*

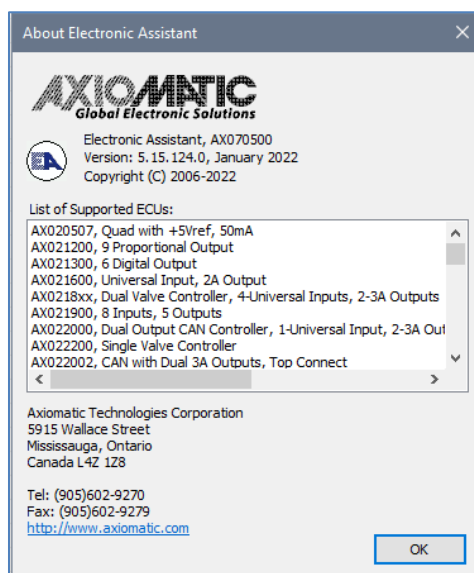

Remember that wild cards in the unit names may present not all the units from the specified range.

Troubleshooting of the Electronic Assistant

The most common error usually reported by customers when the EA is used together with Axiomatic USB-CAN converters is the following.

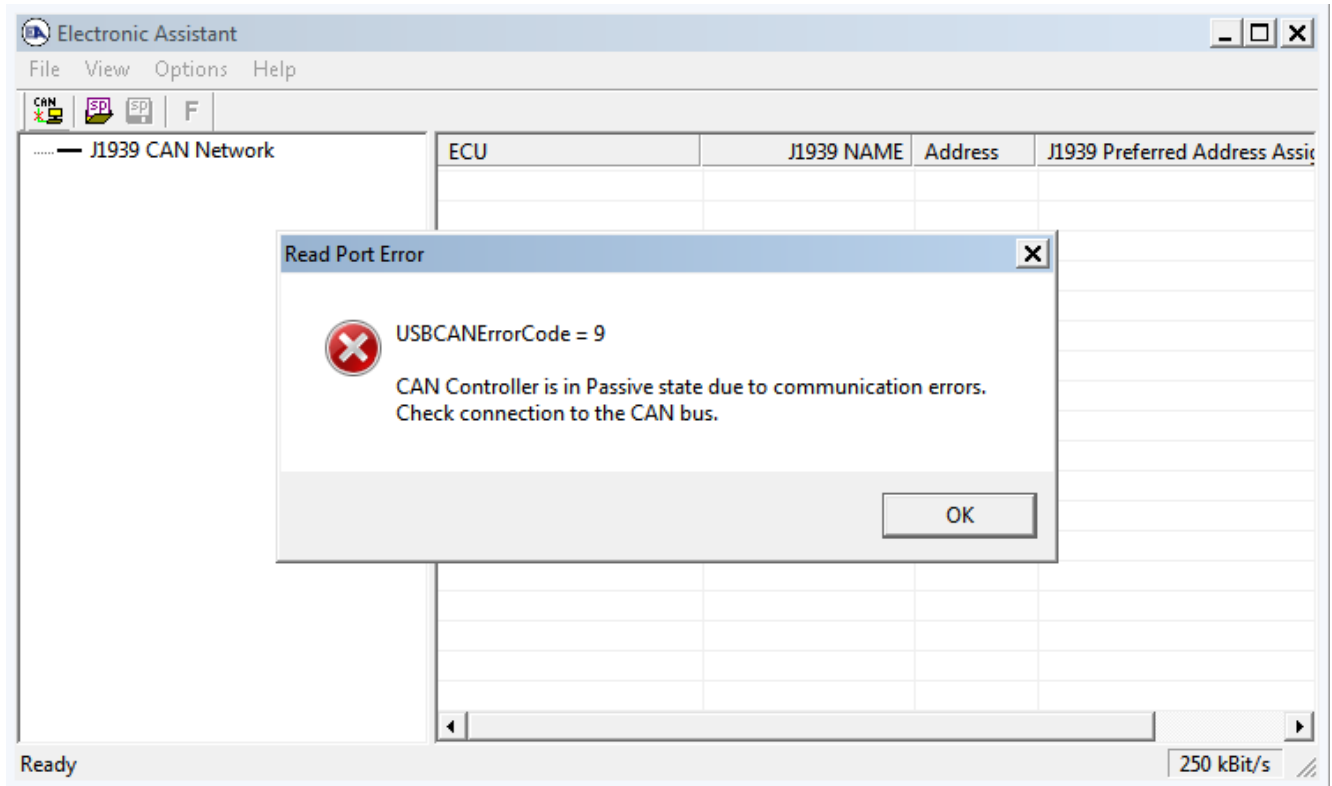

The *CAN LED* in AX070501 or the *Status LED* in AX070505 USB-CAN converter lights up constantly red or is blinking intermittently red.

This error means that the CAN bus is not functioning properly. There are several common reasons why it can happen:

- The Axiomatic USB-CAN Converter is not connected to the CAN network.
- The customer ECU is not powered. Remember that power is not delivered over CAN bus.
- Wrong baud rate has been selected. This is valid only for EA versions 4.3.x.x or higher, which allow baud rate selection for the J1939 CAN bus. Please, check the baud rate indicator located on the right side of the status bar (bottom-right side of the EA window). The most commonly used J1939 standard baud rate is 250 kbit/s. All other baud rate values will be displayed in red color to draw the user's attention.
- There are no external 120 Ohm resistors connected to both ends of the CAN bus. Please, remember that according to J1939 standards (J1939/11 and J1939/15) the J1939 CAN bus should have a linear structure with 120Ohm terminating resistors on both ends and the length no more than 40 meters. ECUs are connected to the bus using cable stubs with the length no more than 1 or 3 meters depending on the standard.



If the user only connects the *Axiomatic USB-CAN Converter* to a stand-alone ECU with a short (1-3 m) CAN cable, it is still necessary to install at least one terminating 120 Ohm resistor to provide normal operation of the CAN transceivers.



- *CAN High* and *CAN Low* wires on the USB-CAN Converter and the CAN bus are mismatched. It is also possible that a *CAN High* or *CAN Low* wire is wrongfully connected to the ground or to the plus battery terminal.
- Two different CAN networks are using the same physical media. It happens when, for example, J1939 ECU is connected to a bus with a CANopen or proprietary CAN ECU. Please, make sure that only J1939 ECUs are connected to the same CAN bus.
- Electrical noise on the bus. Make sure that the CAN bus does not go nearby powerful sources of EMI: DC motors, vehicle ignition wires, etc. If the shielded CAN cable is used, the shield should be connected at only **one** point in the center of the bus to the system (vehicle) ground in a place with the least electrical noise. The shield should also be connected to the shield terminal of the Axiomatic USB-CAN converter and to the appropriate shield terminals of the ECUs.



Please remember that after the normal bus operation is restored and the *CAN LED* in AX070501 or the *Status LED* in AX070505 has become green, the user may still receive error messages a couple of times before being able to open the CAN port without getting an error in the EA.

Axiomatic USB-CAN Converter AX070501

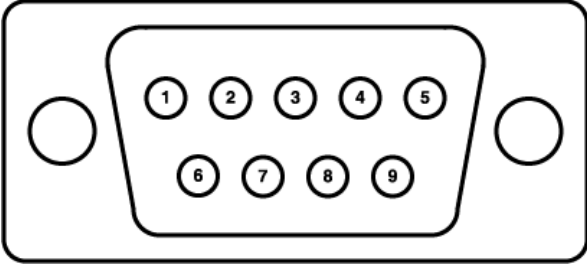
USB-CAN Converter, p/n AX070501, Technical Specifications are presented below.

CAN Interface	Differential, Electrically Isolated, 1 Mbit/s										
Connections	<p>USB socket: USB 1.1 or 2.0 full speed (recommended)</p> <p>CAN: 9-pole DSUB male (DB-9)</p>  <table border="1" data-bbox="539 911 1117 1106"> <thead> <tr> <th>Pin #</th> <th>Signal</th> </tr> </thead> <tbody> <tr> <td>7</td> <td>CAN_H</td> </tr> <tr> <td>2</td> <td>CAN_L</td> </tr> <tr> <td>3</td> <td>CAN_GND</td> </tr> <tr> <td>5</td> <td>SHIELD</td> </tr> </tbody> </table> <p>Figure 2.1. AX070501 DB-9 Pinout.</p> <p>If a shielded cable is used, connect the cable shield wire to the SHIELD pin on the CAN connector. Connect CAN_GND pin to the CAN bus ground, if provided.</p> <p>Optional External Power: 12VDC, 200 mA or higher, standard power plug, 2.5 mm diameter, positive polarity</p>  <p>Figure 2.2. AX070501 Power Supply Plug Pinout.</p>	Pin #	Signal	7	CAN_H	2	CAN_L	3	CAN_GND	5	SHIELD
Pin #	Signal										
7	CAN_H										
2	CAN_L										
3	CAN_GND										
5	SHIELD										
Supply Voltage	<p>By default, the unit should be powered directly from the USB port (5V).</p> <p>External power is only needed if the USB hub on the PC side is not able to provide up to 200 mA current to support the functionality of the converter OR if the user does NOT want to draw power from the USB port in a battery powered computer configuration (i.e. a laptop).</p>										

LED Indicators	USB	Red/Green
	CAN	Red/Green
	Power	Red/Green
	External Power	Green
Refer to the front panel indicator description table for details.		
Microcontroller	ST Micro ARM 7 family	
Dimensions	ABS enclosure Rose & Bopla P/N EG1250F 4.92 x 2.64 x 2.01 inches (L x W x H excluding DB-9 connector) 125 x 67 x 51 mm	
Weight	0.4 lbs (0.18 kg)	
Operating Temperature	-40...75 °C	
Environmental Protection Rating	IP40	

The USB-CAN Converter, p/n AX070501, has four LED indicators on the front panel. They allow the user to monitor USB and CAN port activities, errors, low-power conditions, etc.

The LED indicators display the internal state of the converter the following way.

Indicator	Type	State	Description
USB	Bi-color Red/Green	Blank	The USB port is not enumerated, or the converter is in the Suspended Mode.
		Constantly Green	The USB port is enumerated and ready to send/receive data.
		Blinking Green	The USB port is sending/receiving data.
		Constantly Red	The USB cable is detached from the hub or there are errors during USB transmission or reception.
		Blinking Red	Errors during USB transmission/reception.
CAN	Bi-color Red/Green	Blank	The CAN port has not been initialized or the converter is in the Suspended Mode.
		Constantly Green	The CAN port has been initialized with a specific baud rate and is ready to communicate.
		Blinking Green	The CAN port is sending/receiving data.
		Blinking Red or Constantly Red	Errors during sending/receiving data through the CAN port.
Power	Bi-color Red/Green	Blank	No power or the converter is in the Suspended Mode.
		Constantly Green	The converter power is normal.
		Constantly Red	The converter power is low. External power should be attached if the converter is powered from the USB bus.
External Power	Uni-color Green	Blank	The external power is disconnected.
		Constantly Green	The external power is connected.

To connect the converter to the USB port and the CAN network the following cables can be used.

Part Number	Cable Description						
CBL-USB-AB-MM-1.5	Standard generic USB A to B Cable, 5 ft (1.5m)						
CAB-AX070501	<p>A temporarily CAN connection cable.</p> <p>A cable with a female DB-9 connector and three loose CAN wires, 12 inches (30 cm) long. Wires have the following marking:</p> <table border="1" data-bbox="565 516 1049 621"> <tbody> <tr> <td data-bbox="565 516 821 554">Green (or Red)</td> <td data-bbox="821 516 1049 554">CAN_L</td> </tr> <tr> <td data-bbox="565 554 821 592">Yellow (or White)</td> <td data-bbox="821 554 1049 592">CAN_H</td> </tr> <tr> <td data-bbox="565 592 821 621">Black</td> <td data-bbox="821 592 1049 621">CAN_GND</td> </tr> </tbody> </table>	Green (or Red)	CAN_L	Yellow (or White)	CAN_H	Black	CAN_GND
Green (or Red)	CAN_L						
Yellow (or White)	CAN_H						
Black	CAN_GND						



CAB-AX070501 is provided for evaluation purposes only. The user is responsible for connecting the converter to the CAN network using a reliable wire harness with electrical parameters defined by the network.

10 VERSION HISTORY

UM Version	Date	Author	Modifications
5.12.131	September 2, 2022	Ilona Korpelainen, Weixin Kong, Viktor Rogachov	<p>Added support for:</p> <ul style="list-style-type: none"> AX020512, 6 Inputs, 5 Outputs Valve Controller; AX140170, Isolated J1939-J1939-ModbusRTU Converter; AX140320, J1939-J1939-ModbusRTU Converter; AX140321, J1939-CANopen-ModbusRTU Converter; AX140322, J1939-J1939-J1587 Converter; AX030570, 1 Resistive Output CAN Controller; AX100750, Dual Stepper Motor Drive, 2A, CAN (SAE J1939), 2 AIN, 2 FIN, UOUT, Encoder. <p>Updated support for:</p> <ul style="list-style-type: none"> AX020400, 12 Inputs, 12 Outputs Valve Controller; AX140400, J1939, J1939, J1587 Converter.
5.12.130	July 4, 2022	Dmytro Tsebrii, Viktor Rogachov	<p>Added support for:</p> <ul style="list-style-type: none"> AX180010, 7 Universal Inputs, 3 RTD, 2 Universal Outputs Controller. <p>Updated support for:</p> <ul style="list-style-type: none"> AX032200, 1 Digital Input, 2 Digital Outputs Controller; AX189000, Thermocouple, 2 Universal Input Dual CAN Controller; AX031200, Multi-Function I/O Module 48-pin; AX030440, 4 Universal Inputs, 5V/8V Voltage Reference, CAN Controller.
5.12.129	June 3, 2022	Viktor Rogachov, Olek Bogush	<p>Added support for:</p> <ul style="list-style-type: none"> AX032200, 1 Digital Input, 2 Digital Outputs Controller. <p>Updated support for:</p> <ul style="list-style-type: none"> AX029000, 10-Output Valve Ethernet Driver. <p>Updated <i>Driver Installation</i> section with information on how to disable HVCI.</p>
5.12.128	May 5, 2022	Dmytro Tsebrii, Olek Bogush	<p>Updated support for:</p> <ul style="list-style-type: none"> AX030440, 4 Universal Inputs, 5V/8V Voltage Reference, CAN Controller. <p>In User Manual, added Axiomatic USB-CAN converter p/n AX070505 and converter kit, p/n AX070505K. Updated USB-CAN converter references throughout the document. Moved AX070501 technical description to Appendix D.</p>
5.15.127	April 4, 2022	Dmytro Tsebrii, Ilona Korpelainen, Olek Bogush	<p>Updated support for:</p> <ul style="list-style-type: none"> AX030440, 4 Universal Inputs, 5V/8V Voltage Reference, CAN Controller. <p>Updated AX030120 and AX030130 ECU names. New names are used throughout this manual.</p> <p>Removed support for Windows 2000.</p>
5.15.126	March 3, 2022	Ilona Korpelainen, Peter Sotirakos	<p>Added support for:</p> <ul style="list-style-type: none"> AX020530, 7 Inputs, 5 Outputs Valve Controller. <p>Updated support for:</p> <ul style="list-style-type: none"> AX030120, 10 Universal Signal Input CAN Controller;

UM Version	Date	Author	Modifications
			<ul style="list-style-type: none"> • AX030120-01, 10 Universal Signal Input CAN Controller (500kbit/s); • AX030120-02, 10 Universal Signal Input CAN Controller (1Mbit/s); • AX130540, 2 Inputs, 2 Outputs Isolated Signal Converter; • AX189000, Thermocouple, 2 Universal Input Dual CAN Controller.
5.15.125	February 3, 2022	Dmytro Tsebrii	<p>Added support for:</p> <ul style="list-style-type: none"> • AX180800, 20 Thermocouple, 2 RTD, 4 Inputs, 6 Relays Dual CAN Controller. <p>Updated support for:</p> <ul style="list-style-type: none"> • AX023210, Fan Drive Controller; • AX130750, CAN to 1 Relay and 2 Analog Outputs Converter; • AX130750-01, CAN to 1 Relay and 2 Analog Outputs Converter, 500kbit/s; • AX130750-02, CAN to 1 Relay and 2 Analog Outputs Converter, 1Mbit/s; • AX130770, CAN to 1 Relay and 2 Analog Outputs Converter; • AX130770-01, CAN to 1 Relay and 2 Analog Outputs Converter, 500kbit/s; • AX130770-02, CAN to 1 Relay and 2 Analog Outputs Converter, 1Mbit/s; • AX100310, Universal 25A DC Motor Controller. • AX180800, 20 Thermocouple, 2 RTD, 4 Inputs, 6 Relays Dual CAN Controller. <p>Updated support for customer specific controllers. Updated ECU NAME field assignments.</p>
5.15.124	January 10, 2022	Ilona Korpelainen, Olek Bogush	<p>Added support for:</p> <ul style="list-style-type: none"> • AX100286, 600W 48V BLDC Controller. <p>Updated AX032100 name to: "AX032100, 2 Bipolar, 8 Universal Signal Input Controller, CAN, Ethernet, 2x5V Ref, DIN".</p>
5.15.123	December 1, 2021	Dmytro Tsebrii	<p>Updated support for:</p> <ul style="list-style-type: none"> • AX130750, CAN to 1 Relay and 2 Analog Outputs Converter; • AX130750-01, CAN to 1 Relay and 2 Analog Outputs Converter, 500kbit/s; • AX130750-02, CAN to 1 Relay and 2 Analog Outputs Converter, 1Mbit/s; • AX130770, CAN to 1 Relay and 2 Analog Outputs Converter; • AX130770-01, CAN to 1 Relay and 2 Analog Outputs Converter, 500kbit/s; • AX130770-02, CAN to 1 Relay and 2 Analog Outputs Converter, 1Mbit/s.

UM Version	Date	Author	Modifications
5.15.122	November 1, 2021	Ilona Korpelainen, Dmytro Tsebrii	Added support for: <ul style="list-style-type: none"> AX023240, Quadrature Decoder Input, Dual Valve Controller, High Temperature, SAE J1939; Updated support for: <ul style="list-style-type: none"> AX023300, 2 Inputs, 2 Outputs Valve Controller; AX130520, 2 Inputs, 2 Outputs Signal Converter; AX030440, 4 Universal Inputs, 5V/8V Voltage Reference, CAN Controller.
5.15.121	October 1, 2021	Dmytro Tsebrii	Updated support for: <ul style="list-style-type: none"> AX030440, 4 Universal Inputs, 5V/8V Voltage Reference, CAN Controller; AX030140, 3 Encoder, 7 Signal Inputs Controller, CAN Isolated; AX130550, 4 AC Inputs to 4 Analog Outputs Controller. Added support for a customer specific controller.
5.15.120	September 3, 2021	Dmytro Tsebrii, Ilona Korpelainen, Peter Sotirakos, Jessica Chen	Added support for: <ul style="list-style-type: none"> AX102100, 40A Bidirectional DC Motor Controller; AX141810, RS485-Ethernet-CAN Converter; AX141830, RS485-Ethernet-CAN Converter; AX030440, 4 Universal Inputs, 5V/8V Voltage Reference, CAN Controller; AX200300, 4 Channel Strain Gauge, Open Wire Detection, CAN Controller; AX189000, Thermocouple, 2 Universal Input Dual CAN Controller. Updated support for: <ul style="list-style-type: none"> AX100260, 6A 100W BLDC Controller; AX100270, BLDC and 2 DC Motor Controller; AX130510, 2 Inputs, 2 Outputs Isolated Signal Converter AX181000, 4 TC, 7 Analog, 3 Universal Inputs; AX141120, 1 Universal Input, Dual CAN RTC Controller.
5.15.119	August 3, 2021	Dmytro Tsebrii	Added support for: <ul style="list-style-type: none"> AX141120, 1 Universal Input Dual CAN RTC Controller. Updated support for: <ul style="list-style-type: none"> AX031500, Magnetic Pick-up Input with CAN; AX100310, Universal 25A DC Motor Controller.
5.15.118	June 5, 2021	Jessica Chen, Dmytro Tsebrii Olek Bogush	Added support for: <ul style="list-style-type: none"> AX030540, CAN to 4 Analog Outputs Controller; AX130550, 4 AC Inputs to 4 Analog Outputs Controller. Updated License Agreement.
5.15.117A	June 1, 2021	Olek Bogush	Removed registered trademark symbol ® from Electronic Assistant throughout the document.
5.15.117	March 2, 2021	Ilona Korpelainen,	Added support for: <ul style="list-style-type: none"> AX100280, 100W 48V BLDC Controller; AX140510, PLC to J1939 Protocol Converter;

UM Version	Date	Author	Modifications
		Peter Sotirakos, Olek Bogush	<ul style="list-style-type: none"> AX142100, Protocol Converter; AX022950, 7 Digital Inputs, 6 Digital Outputs, 4 LED Outputs Controller. <p>Updated support for:</p> <ul style="list-style-type: none"> AX023300, 2 Inputs, 2 Outputs Valve Controller; AX023302, A061D644, 2 Inputs, 2 Outputs Controller; AX100260, 6A 100W BLDC Controller; AX104001, Throttle Valve Controller; AX105000, 150A Bi-directional DC Motor Controller; AX140400, J1939, J1939, J1587 Converter; AX184000, 12 RTD, 4 Universal Inputs; AX186000, Six Channel Thermocouple Scanner. <p>Removed support for AX140501, PLC to J1939 Protocol Converter. It was replaced with AX140510.</p> <p>Updated AX032100 name to "2 Bipolar, 8 Universal Signal Input Controller, CAN (SAE J1939), Ethernet (Modbus TCP/IP), Two +5V Ref, DIN".</p>
5.15.116	February 1, 2021	Ilona Korpelainen	<p>Added support for:</p> <ul style="list-style-type: none"> AX022460, Two Bipolar Inputs, Four Pulse Valve Outputs Controller; AX100240, 50W BLDC Controller; AX130522, 2 Inputs, 2 Outputs Isolated Signal Converter; AX188000, Two Channel Thermocouple Scanner. <p>Updated support for:</p> <ul style="list-style-type: none"> AX104001, Throttle Valve Controller; AX130520, 2 Inputs, 2 Outputs Signal Converter; AX130540, 2 Inputs, 2 Outputs Isolated Signal Converter; AX140100, J1939-J1939-ModbusRTU Converter; AX140200, J1939-CANopen-ModbusRTU Converter; AX140400, J1939, J1939, J1587 Converter.
5.15.115	December 16, 2020	Gustavo Del Valle, Peter Sotirakos, Erik Sasse	<p>Added support for:</p> <ul style="list-style-type: none"> AX030140, 3 Encoder, 7 Signal Inputs Controller, CAN Isolated; AX100310, Universal 25A DC Motor Controller; AX030550, Isolated Dual CAN to Sine or Square Output; AX029000, 10-Output Valve Ethernet Driver. <p>Updated support for customer specific inclinometers.</p>
5.15.114	November 2, 2020	Jessica Chen	<p>Added support for:</p> <ul style="list-style-type: none"> AX030600, 6 Universal Signal Input Controller, SAE J1939, Ethernet.
5.15.113	June 17, 2020	Olek Bogush	<p>Added support for:</p> <ul style="list-style-type: none"> AX032100, 2 Bipolar, 8 Universal Signal Input Controller, SAE J1939, Ethernet.
5.15.112	June 1, 2020	Gustavo Del Valle	<p>Updated support for:</p> <ul style="list-style-type: none"> AX031705, Single Input Controller with CAN.

UM Version	Date	Author	Modifications
			Added and updated support for customer specific inclinometers.
5.15.111	April 1, 2020	Ilona Korpelainen	Updated support for: <ul style="list-style-type: none"> AX024000, Servo Controller; AX024010, DIN Rail Servo Controller.
5.15.110	March 17, 2020	Ilona Korpelainen	Added support for: <ul style="list-style-type: none"> AX105000, 150A Bi-directional DC Motor Controller; AX186000, Six Channel Thermocouple Scanner.
5.15.109	February 3, 2020	Jessica Chen, Ilona Korpelainen, Peter Sotirakos	Added support for: <ul style="list-style-type: none"> AX090550, 12VDC Battery Charger; AX090560, 12/24VDC Battery Charger 15A. Updated support for: <ul style="list-style-type: none"> AX130510, 2 Inputs, 2 Outputs Isolated Signal Converter; AX130520, 2 Inputs, 2 Outputs Signal Converter; AX130540, 2 Inputs, 2 Outputs Isolated Signal Converter; AX130700, CAN to PWM Output Controller; AX130750, CAN to 1 Relay and 2 Analog Outputs Converter; AX130750-01, CAN to 1 Relay and 2 Analog Outputs Converter, 500kbit/s; AX130750-02, CAN to 1 Relay and 2 Analog Outputs Converter, 1Mbit/s; AX130770, CAN to 1 Relay and 2 Analog Outputs Converter; AX130770-01, CAN to 1 Relay and 2 Analog Outputs Converter, 500kbit/s; AX130770-02, CAN to 1 Relay and 2 Analog Outputs Converter, 1Mbit/s.
5.15.108	December 13, 2019	Olek Bogush	Updated support for: <ul style="list-style-type: none"> AX061000, Tri-Axial J1939 CAN Inclinometer with Analog Outputs; AX140600-03, LIN - J1939 CAN Converter. Added 667 kbit/s baud rate support. Updated <i>Connecting to J1939 CAN</i> subsection.
5.14.107	November 1, 2019	Ilona Korpelainen	Updated support for: <ul style="list-style-type: none"> AX102000, 35A Bidirectional DC Motor Controller; AX184000, 12 RTD, 4 Universal Inputs.
5.14.106	October 3, 2019	Gustavo Del Valle, Jessica Chen, Ilona Korpelainen, Erik Sasse	Added support for: <ul style="list-style-type: none"> AX031705, Single Input Controller with CAN; AX031950, Bipolar Input, Relay Output and Analog Output with NFC; AX130750, CAN to 1 Relay and 2 Analog Outputs Converter; AX130750-01, CAN to 1 Relay and 2 Analog Outputs Converter, 500kbit/s;

UM Version	Date	Author	Modifications
			<ul style="list-style-type: none"> • AX130750-02, CAN to 1 Relay and 2 Analog Outputs Converter, 1Mbit/s; • AX130770, CAN to 1 Relay and 2 Analog Outputs Converter; • AX130770-01, CAN to 1 Relay and 2 Analog Outputs Converter, 500kbit/s; • AX130770-02, CAN to 1 Relay and 2 Analog Outputs Converter, 1Mbit/s; • AX030130, 10 Universal Signal Input with 5V Reference Output; • AX030130-01, 10 Universal Signal Input with 5V Reference Output, 500kbit/s; • AX030130-02, 10 Universal Signal Input with 5V Reference Output, 1Mbit/s; • AX185000, Twenty Channel Thermocouple Scanner; • AX185000-01, Twenty Channel Thermocouple Scanner, 500kbit/s; • AX185000-02, Twenty Channel Thermocouple Scanner, 1Mbit/s; • AX031850, Twelve Digital Inputs, Eight Discrete Outputs, Cinch Connector; • AX031850-01, Twelve Digital Inputs, Eight Discrete Outputs, Cinch Connector, 500kbit/s; • AX031850-02, Twelve Digital Inputs, Eight Discrete Outputs, Cinch Connector, 1Mbit/s; • AX031800-01, Twelve Digital Inputs, Eight Discrete Outputs Controller, 500kbit/s; • AX031800-02, Twelve Digital Inputs, Eight Discrete Outputs Controller, 1Mbit/s; <p>Updated support for:</p> <ul style="list-style-type: none"> • AX020200, Dual Output Valve Controller with CAN; • AX031800, Twelve Digital Inputs, Eight Discrete Outputs Controller; • AX020510, Valve Controller, 6 Inputs, 5 Outputs; • AX031200, Multi-Function I/O Module 48-pin; • AX030310, 18 Digital Input to CAN Controller. <p>Updated EA names for AX030210, AX100270, AX102000, AX140920, AX141100, AX141150.</p>
5.14.105	August 6, 2019	Olek Bogush	<p>Updated support for:</p> <ul style="list-style-type: none"> • AX060800, AX060830, Tri-Axial J1939 CAN Inclinometer – Two M12 Connectors, Both CAN; • AX060806, AX060810, Tri-Axial J1939 CAN Inclinometer – One Deutsch DT15-4P Connector; • AX060807, AX060811, Tri-Axial J1939 CAN Inclinometer – One Deutsch DT15-4P Connector with CAN Termination; • AX061000, Tri-Axial J1939 CAN Inclinometer with Analog Outputs;

UM Version	Date	Author	Modifications
			<ul style="list-style-type: none"> • AX060900, Tri-Axial Gyro Inclinometer, SAE J1939; • AX060910, Tri-Axial Gyro Inclinometer with Extended Dynamic Range, SAE J1939; • AX062008, Tri-Axial Inclinometer with Single-Axis Gyro, Vertical Mount, SAE J1939; • AX062018, Tri-Axial Inclinometer with Single-Axis Gyro, Extended Dynamic Range, Vertical Mount, SAE J1939; • AX060700, Tri-Axial J1939 CAN Inclinometer with Gyro. Two M12 Connectors, Both CAN; • AX060701, Tri-Axial J1939 CAN Inclinometer with Gyro. Two M12 Connectors, CAN, 4 Analog Outputs; • AX060702, Tri-Axial J1939 CAN Inclinometer with Gyro. Two M12 Connectors, CAN, RS-232.
5.14.104	July 2, 2019	Ilona Korpelainen	<p>Added support for:</p> <ul style="list-style-type: none"> • AX0224400, Two Bipolar Inputs, Two Universal Inputs, Two Proportional Outputs Controller; <p>Updated support for:</p> <ul style="list-style-type: none"> • AX030310, 18 Digital Input to CAN Controller; • AX140100, J1939-J1939-ModbusRTU Converter; • AX140200, J1939-CANopen-ModbusRTU Converter; • AX140400, J1939, J1939, J1587 Converter.
5.14.103	June 18, 2019	Olek Bogush	<p>Updated <i>Using the Electronic Assistant</i> section. Updated <i>Multiple ECU Instances</i> subsection. Added <i>Changing ECU Address</i> subsections.</p> <p>Updated figures in <i>USB-CAN Converter</i> section.</p>
5.13.103	June 3, 2019	Olek Bogush	<p>Updated support for:</p> <ul style="list-style-type: none"> • AX060800, AX060830, Tri-Axial J1939 CAN Inclinometer – Two M12 Connectors, Both CAN; • AX060806, AX060810, Tri-Axial J1939 CAN Inclinometer – One Deutsch DT15-4P Connector; • AX060807, AX060811, Tri-Axial J1939 CAN Inclinometer – One Deutsch DT15-4P Connector with CAN Termination; • AX061000, Tri-Axial J1939 CAN Inclinometer with Analog Outputs; • AX060900, Tri-Axial Gyro Inclinometer, SAE J1939; • AX060910, Tri-Axial Gyro Inclinometer with Extended Dynamic Range, SAE J1939; • AX062008, Tri-Axial Inclinometer with Single-Axis Gyro, Vertical Mount, SAE J1939; • AX062018, Tri-Axial Inclinometer with Single-Axis Gyro, Extended Dynamic Range, Vertical Mount, SAE J1939; • AX060700, Tri-Axial J1939 CAN Inclinometer with Gyro. Two M12 Connectors, Both CAN; • AX060700-01, Tri-Axial J1939 CAN Inclinometer with Gyro. Two M12 Connectors, Both CAN, 500 kbit/s; • AX060701, Tri-Axial J1939 CAN Inclinometer with Gyro. Two M12 Connectors, CAN, 4 Analog Outputs;

UM Version	Date	Author	Modifications
			<ul style="list-style-type: none"> AX060702, Tri-Axial J1939 CAN Inclinometer with Gyro. Two M12 Connectors, CAN, RS-232. Clarified the UM version number rules in <i>Version History</i> .
5.13.102	March 7, 2019	Erik Sasse, Jessica Chen, Peter Sotirakos, Gustavo Del Valle, Ilona Korpelainen	Added support for: <ul style="list-style-type: none"> AX031800, Twelve Digital Inputs, Eight Discrete Outputs Controller; AX021100, 2.5A Connector Amplifier with CAN; AX032000, 18-Cell Battery Monitoring System; AX032050, 16-Cell Battery Monitoring System; AX200100, 12-Channel Strain Gauge with TARE Controller; AX200102, 12-Channel Strain Gauge Controller; Updated support for: <ul style="list-style-type: none"> AX031901, Single Digital Input to Dual NC Relay Outputs; AX200000, 4 Channel Strain Gauge Controller; AX023300, 2 Inputs, 2 Outputs Valve Controller; AX024010, DIN Rail Servo Controller; AX140100, J1939-J1939-ModbusRTU Converter;
5.13.101	February 1, 2019	Ilona Korpelainen	Added support for: <ul style="list-style-type: none"> AX023302, A061D644, 2 Inputs, 2 Outputs Controller. Updated support for: <ul style="list-style-type: none"> AX020410, 12 Inputs, 12 Outputs Valve Controller; AX030120, 10 Universal Signal Input CAN Controller; AX030210, 12IN-8SOUT-1RLYOUT (12 Input, 8 Signal Output & 1 Relay Output Controller); AX100260, 6A 100W BLDC Controller; AX130510, 2 Inputs, 2 Outputs Isolated Signal Converter; AX140100, J1939-J1939-ModbusRTU Converter; AX180400, Laser Receiver.
5.13.100	January 8, 2019	Olek Bogush	Updated support for: <ul style="list-style-type: none"> AX060800, AX060830, Tri-Axial J1939 CAN Inclinometer – Two M12 Connectors, Both CAN; AX060808, AX060838, Tri-Axial J1939 CAN Inclinometer – Vertical Mount, Two M12 Connectors, Both CAN; AX060806, AX060810, Tri-Axial J1939 CAN Inclinometer – One Deutsch DT15-4P Connector; AX060807, AX060811, Tri-Axial J1939 CAN Inclinometer – One Deutsch DT15-4P Connector with CAN Termination; AX061000, Tri-Axial J1939 CAN Inclinometer with Analog Outputs; AX060900, Tri-Axial Gyro Inclinometer, SAE J1939; AX060910, Tri-Axial Gyro Inclinometer with Extended Dynamic Range, SAE J1939;

UM Version	Date	Author	Modifications
			<ul style="list-style-type: none"> AX062008, Tri-Axial Inclinometer with Single-Axis Gyro, Vertical Mount, SAE J1939; AX062018, Tri-Axial Inclinometer with Single-Axis Gyro, Extended Dynamic Range, Vertical Mount, SAE J1939.
5.13.99	December 6, 2018	Olek Bogush	<p>Added support for:</p> <ul style="list-style-type: none"> AX062008, Tri-Axial Inclinometer with Single-Axis Gyro, Vertical Mount, SAE J1939; AX062018, Tri-Axial Inclinometer with Single-Axis Gyro, Extended Dynamic Range, Vertical Mount, SAE J1939. <p>Corrected support for:</p> <ul style="list-style-type: none"> AX060800, AX060830, Tri-Axial J1939 CAN Inclinometer – Two M12 Connectors, Both CAN; AX060806, AX060810, Tri-Axial J1939 CAN Inclinometer – One Deutsch DT15-4P Connector; AX060807, AX060811, Tri-Axial J1939 CAN Inclinometer – One Deutsch DT15-4P Connector with CAN Termination; <p>In <i>USB-CAN Converter</i> section, added <i>Connecting USB-CAN Converter to CAN Bus</i>, <i>Connecting USB-CAN Converter to CAN Device on the Bench</i>, and <i>Technical Specifications</i> subsections. In <i>Technical Specifications</i> subsection added <i>Operating Temperature</i>, <i>CAN_GND</i> and <i>SHIELD</i> pin description.</p>
5.13.98	October 2, 2018	Ilona Korpelainen, Gustavo Del Valle, Olek Bogush	<p>Added support for:</p> <ul style="list-style-type: none"> AX022420, Four Inputs, Two Outputs Universal Valve Controller; AX030210, 12IN-8SOUT-1RLYOUT; AX180400, Laser Receiver. AX060910, Tri-Axial Gyro Inclinometer with Extended Dynamic Range; <p>Added support for customer specific inclinometers.</p> <p>Updated support for:</p> <ul style="list-style-type: none"> AX031700, Single Input Controller with CAN; AX200000, 4 Channel Strain Gauge Controller; AX020400, 12 Inputs, 12 Outputs Valve Controller; AX020410, 12 Inputs, 12 Outputs Valve Controller; AX020510, Valve Controller, 6 Inputs, 5 Outputs; AX024010, DIN Rail Servo Controller; AX030120, 10 Universal Signal Input CAN Controller; AX130540, 2 Inputs, 2 Outputs Isolated Signal Converter; AX184000, 12 RTD, 4 Universal Inputs. <p>Corrected support for:</p> <ul style="list-style-type: none"> AX061000, Tri-Axial J1939 CAN Inclinometer with Analog Outputs.
5.13.97	June 8, 2018	Ilona Korpelainen, Gustavo	<p>Added support for:</p> <ul style="list-style-type: none"> AX130540, 2 Inputs, 2 Outputs Isolated Signal Converter;

UM Version	Date	Author	Modifications
		Del Valle, Olek Bogush	<ul style="list-style-type: none"> • AX020520, 6 Inputs, 5 Outputs Valve Controller; • AX141150, CAN-BT-APPL (CAN-Bluetooth Converter); • AX140920, MMS-ENET-BPS (BPS Master Module); • AX061000, Tri-Axial J1939 CAN Inclinator with Analog Outputs. <p>Updated support for:</p> <ul style="list-style-type: none"> • AX023300, 2 Inputs, 2 Outputs Valve Controller; • AX022003, Universal Input, Dual Valve Output CAN Controller; • AX200000, 4 Channel Strain Gauge Controller; • AX031500, Magnetic Pick-up Input with CAN; • AX031700, Single Input Controller with CAN; • AXDIO128-03, 12 Digital Input, 8 Relay Output Controller; • AX020510, Valve Controller, 6 Inputs, 5 Outputs; • AX102000, BI-35A-DC-MC (35A Bidirectional DC Motor Controller); • AX104001, Throttle Valve Controller; • AX140200, J1939-CANopen-ModbusRTU Converter. <p>In the User Manual:</p> <ul style="list-style-type: none"> • Updated color code for CAB-AX070501; • Updated Finnish office phone number on the front page.
5.13.96	March 5, 2018	Ilona Korpelainen, Gustavo Del Valle, Olek Bogush	<p>Added support for:</p> <ul style="list-style-type: none"> • AX090600, 24VDC to 14VDC 2A Battery Charger; • AX031901, Single Digital Input to Dual NC Relay Outputs; • AX023300, 2 Inputs, 2 Outputs Valve Controller; • AX100270, BLDC-2DCM-AXIO (BLDC and 2 DC Motor Controller). <p>Updated support for:</p> <ul style="list-style-type: none"> • AX021610, Single Input Single Valve Output Controller; • AX030120, 10 Universal Signal Input CAN Controller; • AX102000, BI-35A-DC-MC (35A Bidirectional DC Motor Controller); • AX140100, J1939-J1939-ModbusRTU Converter; • AX184000, 12 RTD, 4 Universal Inputs.
5.13.95	February 1, 2018	Olek Bogush	<p>Added Electronic Assistant Kit, P/N: AX070502 – AX070501 USB-CAN Converter, 2 Cables, Installation Instructions.</p> <p>Added support for:</p> <ul style="list-style-type: none"> • AX060900, Tri-Axial Gyro Inclinator, SAE J1939.
5.13.94	December 29, 2017	Ilona Korpelainen	<p>Added support for:</p> <ul style="list-style-type: none"> • AX102000, BI-35A-DC-MC (35A Bidirectional DC Motor Controller). <p>Updated support for:</p> <ul style="list-style-type: none"> • AX130520, 2 Inputs, 2 Outputs Signal Converter.

UM Version	Date	Author	Modifications
5.13.93	October 2, 2017	Ilona Korpelainen	Added support for: <ul style="list-style-type: none"> AX030320, 18 Digital Input to CAN Controller; AX140100-100, J1939-J1939-ModbusRTU Converter. Updated support for: <ul style="list-style-type: none"> AX020410, 12 Inputs, 12 Outputs Valve Controller; AX030120, 10 Universal Signal Input CAN Controller.
5.13.92	August 1, 2017	Olek Bogush, Ilona Korpelainen	Removed support for <i>Electronic Assistant installation CD, AX070502IN</i> . Updated Software Installation section. Updated support for: <ul style="list-style-type: none"> AX030310, 18 Digital Input to CAN Controller.
5.13.91	July 5, 2017	Ilona Korpelainen	Updated support for: <ul style="list-style-type: none"> AX024010, DIN Rail Servo Controller; AX020510, Valve Controller, 6 Inputs, 5 Outputs; AX031200, Multi-Function IO Module 48-pin.
5.13.90	June 2, 2017	Olek Bogush, Ilona Korpelainen	Added support for: <ul style="list-style-type: none"> AX020410, 12 Inputs, 12 Outputs Valve Controller; AX184000, 12 RTD, 4 Universal Inputs. Updated support for: <ul style="list-style-type: none"> AX060800, Tri-axial J1939 CAN Inclinator – Two M12 Connectors, Both CAN; AX060804, Tri-axial J1939 CAN Inclinator – One M12 Connector, CAN; AX060806, Tri-axial J1939 CAN Inclinator – One Deutsch DT15-4P Connector; AX060807, Tri-axial J1939 CAN Inclinator – One Deutsch DT15-4P Connector with CAN Termination; AX020510, Valve Controller, 6 Inputs, 5 Outputs; AX021210, AX021210-01, AX021210-02, 10 Output Valve Controller; AXTC20, Twenty Thermocouple Scanner; AXRTD8, Eight RTD Scanner. Added to the list of supported Axiomatic ECUs: <ul style="list-style-type: none"> AX060808, Tri-axial J1939 CAN Inclinator – Vertical Mount, Two M12 Connectors, Both CAN; AX060830, Tri-axial J1939 CAN Inclinator – Two M12 Connectors, Both CAN; AX060838, Tri-axial J1939 CAN Inclinator – Vertical Mount, Two M12 Connectors, Both CAN; AX060810, Tri-axial J1939 CAN Inclinator – One DT15-4P Connector; AX060811, Tri-axial J1939 CAN Inclinator – One DT15-4P Connector, CAN Termination.
5.13.89	May 2, 2017	Ilona Korpelainen, Olek Bogush	Added support for: <ul style="list-style-type: none"> AX130520, 2 Inputs, 2 Outputs Signal Converter; AX024010, DIN Rail Servo Controller. Updated support for: <ul style="list-style-type: none"> AX020510, Valve Controller, 6 Inputs, 5 Outputs;

UM Version	Date	Author	Modifications
			<ul style="list-style-type: none"> AX030120, 10 Universal Signal Input CAN Controller; AX130700, CAN to PWM Output Controller; AX140200, J1939-CANopen-ModbusRTU Converter. Updated List of Supported Axiomatic ECUs.
5.13.88	March 1, 2017	Olek Bogush, Ilona Korpelainen	Added support for: <ul style="list-style-type: none"> AX140600-03, LIN - J1939 CAN Converter. Updated support for: <ul style="list-style-type: none"> AX100260, 6A 100W BLDC Controller; AX021210, 10 Output Valve Controller; AX130510, 2 Inputs, 2 Outputs Isolated Signal Converter; AX020400, 12 Inputs, 12 Outputs Valve Controller. Added to the list of supported Axiomatic ECUs: <ul style="list-style-type: none"> AX140600-01, LIN - J1939 CAN Converter (500kbit/s); AX060700-01, Tri-axial J1939 CAN Inclinator with Gyro. Two M12 Connectors, Both CAN (500kbit/s); AX060806, Tri-axial J1939 CAN Inclinator – One Deutsch DT15-4P Connector; AX060807, Tri-axial J1939 CAN Inclinator – One Deutsch DT15-4P Connector with CAN Termination.
5.13.87	February 1, 2017	Ilona Korpelainen	Updated support for: <ul style="list-style-type: none"> AX100260, 6A 100W BLDC Controller; AX140100, J1939-J1939-ModbusRTU Converter; AX104001, Throttle Valve Controller; AX030310, 18 Digital Input to CAN Controller.
5.13.86	January 3, 2017	Gustavo Del Valle	Updated support for: <ul style="list-style-type: none"> AX031700, Single Input Controller with CAN; AX100100, Generic 25A DC Motor Controller. Added support for: <ul style="list-style-type: none"> AX031500, Magnetic Pick-up Input with CAN.
5.13.85	December 5, 2016	Ilona Korpelainen	Updated support for: <ul style="list-style-type: none"> AX140100, J1939-J1939-ModbusRTU Converter; AX024000, Servo Controller; AX020510, Valve Controller, 6 Inputs, 5 Outputs. Added support for: <ul style="list-style-type: none"> AX030160, 8 Digital Input to CAN Controller; AX100260, 6A 100W BLDC Controller; AX100265, 6A 100W BLDC Controller; AX141100, CAN-Bluetooth (CAN-Bluetooth Converter and Datalogger); AX104001, Throttle Valve Controller; AX020400, 12 Inputs, 12 Outputs Valve Controller.
5.13.84	October 3, 2016	Olek Bogush	Updated reading and programming setpoint file operations. Added operation for comparing ECU configuration parameters with setpoint file. Changed menu item <i>Flash setpoints into selected ECU</i> to <i>Program Setpoints into ECU</i> in setpoint file viewer menu. Changed the name of the

UM Version	Date	Author	Modifications
			programming progress bar window from <i>Flashing Setpoint Parameters from File...</i> to <i>Programming Setpoint Parameters from File</i> . Updated support for the following families: <ul style="list-style-type: none"> AX06070x, Tri-axial J1939 CAN Inclometers with Gyro; AX06080x, Tri-axial J1939 CAN Inclometers.
5.12.84	September 7, 2016	Ilona Korpelainen	Updated support for: <ul style="list-style-type: none"> AX140200, J1939-CANopen-ModbusRTU Converter; AX024000, Servo Controller; AX030120, 10 Universal Signal Input CAN Controller.
5.12.83	August 2, 2016	Gustavo Del Valle, Olek Bogush	Updated support for: <ul style="list-style-type: none"> AX021610, Single Input Single Valve Output Controller; AX022000, Dual Output CAN Controller, 1-Universal Input, 2 - 3A Outputs; AX020510, Valve Controller, 6 Inputs, 5 Outputs. Changed kBit/s to kbit/s.
5.11.83	June 10, 2016	Olek Bogush, Gustavo Del Valle, Ilona Korpelainen	Clarified <i>APPENDIX A</i> . Added support for: <ul style="list-style-type: none"> AX031702, Fuel Sensor Input to CAN Controller; AX031700, Single Input Controller with CAN. Updated support for: <ul style="list-style-type: none"> AXDIO128-03, 12 Digital Input, 8 Relay Output Controller; AX021610, Single Input Single Valve Output Controller; AX023220, 2 Input 2 Output High Temperature Controller.
5.11.82	May 5, 2016	Olek Bogush, Ilona Korpelainen	Added support for: <ul style="list-style-type: none"> <i>Axiomatic Ethernet-CAN Converter</i>. Updated: <i>4.4.1 Electronic Assistant Hardware Support, 5.1 Hardware Requirements, 5.2 Connecting to J1939 CAN, APPENDIX A</i> . Updated and clarified other parts of the User Manual. Added description of the <i>Virtual ECU</i> and <i>Decimal Format</i> option in <i>5.2 Connecting to J1939 CAN</i> . Added support for: <ul style="list-style-type: none"> AX024000, Servo Controller.
4.11.81	April 4, 2016	Olek Bogush	Added support for: <ul style="list-style-type: none"> AX060800, Tri-axial J1939 CAN Inclometer – Two M12 Connectors, Both CAN; AX060804, Tri-axial J1939 CAN Inclometer – One M12 Connector, CAN.
4.11.80	January 4, 2016	Olek Bogush, Gustavo Del Valle	Updated <i>Flash Application Firmware</i> dialog window in Fig. 10-1 and Fig. 10-2. Added spaces to separate multi-line comments in <i>Application Firmware Flashing Comments</i> field in the <i>Bootloader Information</i> screen. Added support for: <ul style="list-style-type: none"> AX021610, Single Input Single Valve Output Controller;

UM Version	Date	Author	Modifications
			<ul style="list-style-type: none"> AX020200, Dual Output Valve Controller with CAN. Updated support for: <ul style="list-style-type: none"> AX200000, 4 Channel Strain Gauge Controller.
4.10.79	November 3, 2015	Ilona Korpelainen	Updated support for: <ul style="list-style-type: none"> AX130510, 2 Inputs, 2 Outputs Isolated Signal Converter. Corrected its name. AX140200, J1939-CANopen-ModbusRTU Converter; AX140100, J1939-J1939-ModbusRTU Converter; AX140400, J1939, J1939, J1587 Converter; AX130700, CAN to PWM Output Controller.
4.10.78	September 2, 2015	Gustavo Del Valle, Olek Bogush	Added support for: <ul style="list-style-type: none"> AXDIO128-03, 12 Digital Input, 8 Relay Output Controller; AX022003, Universal Input, Dual Valve Output CAN Controller. Updated support for: <ul style="list-style-type: none"> AX140200, J1939-CANopen-ModbusRTU Converter; AX181000, 4 TC, 7 Analog, 3 Universal Inputs; AX140100, J1939-J1939-ModbusRTU Converter; AX031200, Multi-Function IO Module 48-pin. Updated the <i>List of Supported Axiomatic ECUs</i> table in <i>Appendix B</i> of the user manual.
4.10.77	July 9, 2015	Olek Bogush, Gustavo Del Valle	Added user prompt if saving a setpoint file can erase an already existing file. Clarified the list of supported ECUs dialog in <i>Appendix B</i> of the user manual. Updated support for: <ul style="list-style-type: none"> AX020510, Valve Controller, 6 Inputs, 5 Outputs; AX140100, J1939-J1939-ModbusRTU Converter; AX140400, J1939, J1939, J1587 Converter; AX030120, 10 Universal Signal Input CAN Controller; AX031200, Multi-Function I/O Module 48-pin. Added support for: <ul style="list-style-type: none"> AX023220, 2 Input 2 Output High Temperature Controller; AX200000, 4 Channel Strain Gauge Controller; AX130510, 2 Inputs, 2 Outputs Isolated Signal Converter; AX130700, CAN to PWM Output Controller.
4.9.76A	June 8, 2015	Olek Bogush	Corrected <i>Version History</i> table format.
4.9.76	February 4, 2015	Gustavo Del Valle, Olek Bogush	Updated support for: <ul style="list-style-type: none"> AX140200, J1939-CANopen-ModbusRTU Converter; AX021900, Valve Controller, 8 Inputs, 5 Outputs; AX140600, LIN - J1939 CAN Converter; AX140601, LIN - J1939 CAN Converter; Added support for:

UM Version	Date	Author	Modifications
			<ul style="list-style-type: none"> AX140602, LIN - J1939 CAN Converter. Added support for a customer-specific ECU.
4.9.75	January 5, 2015	Gustavo Del Valle, Olek Bogush	Added support for: <ul style="list-style-type: none"> AX030310, 18 Digital Input to CAN Controller. Updated the <i>File Location</i> sub-section in the <i>Software Installation</i> section to match the new Axiomatic website design.
4.9.74	November 24, 2014	Gustavo Del Valle, Olek Bogush	Changed <i>Software Installation. System Requirements</i> section. Updated UM version history rules in the <i>Version History</i> section. Added support for: <ul style="list-style-type: none"> AX02121x, 10 Output Valve Controller; AX06070x, Tri-axial J1939 CAN Inclinometer with Gyro.
4.9.73	September 2, 2014	Gustavo Del Valle, Olek Bogush	Added support for customer specific ECUs. Changed names of AX06020x and AX06040x inclinometers and some customer specific ECUs.
4.9.70	August 6, 2014	Gustavo Del Valle, Olek Bogush	Added support for customer specific ECUs. Added support for: <ul style="list-style-type: none"> AX020510, 6 Inputs, 5 Outputs Valve Controller. Updated support for: <ul style="list-style-type: none"> AX031200, Multi-Function IO Module 48-pin; AX03012x, 10 Analog Input (added support for 500 kbit/s baud rate); AX030520, 1 Analog Signal Output CAN Controller.
4.9.67	May 28, 2014	Olek Bogush, Gustavo Del Valle	Added support for customer specific ECUs.
4.9.65	April 15, 2014	Olek Bogush	Added <i>Generate Setpoint Text File</i> option to the <i>Options</i> main menu. Reviewed: <i>Overview</i> section, <i>Software Installation</i> sections. In <i>Using the Electronic Assistant</i> section, added <i>Hardware Requirements</i> sub-section, updated <i>Connecting to the J1939 Bus</i> subsection. Added the baud rate change password. Updated <i>Saving Setpoints</i> sub-section. Updated <i>Troubleshooting of the Electronic Assistant</i> section.
4.8.65	April 7, 2014	Gustavo Del Valle, Olek Bogush	Added support for: <ul style="list-style-type: none"> AX0232x0, Fan Drive Controller. Supported AX023210 part number. Added a progress bar for <i>Save Setpoints, Save Setpoints As...</i> operations. Added an .xml file extension if no extension for a setpoint file is specified during a setpoint saving operation.
4.7.64	April 3, 2014	Gustavo Del Valle	Added support for a customer-specific ECU.

UM Version	Date	Author	Modifications
4.7.63	April 2, 2014	Olek Bogush	Added support for: <ul style="list-style-type: none"> AX140600, LIN - J1939 CAN Converter.
4.7.62	March 12, 2014	Olek Bogush	Added support for: <ul style="list-style-type: none"> AX140601, LIN - J1939 CAN Converter.
4.7.61	January 31, 2014	Olek Bogush, Gustavo Del Valle	Added an hourglass together with the "ECU is busy..." animated message, Fig 4-23, during ECU flashing operation. Added support for: <ul style="list-style-type: none"> AX031200, Multi-Function I/O Module 48-pin.
4.6.60	December 27, 2013	Olek Bogush	Added an hourglass together with the "ECU is busy..." animated message, Fig 4-10, when writing setpoints. Added support for a customer-specific PMSM Motor Drive.
4.5.59	November 8, 2013	Gustavo Del Valle	Added support for: <ul style="list-style-type: none"> AX030120, 10 Universal Signal Input CAN Controller; AX140406, J1939, J1939, J1587 Converter.
4.5.57	October 11, 2013	Gustavo Del Valle	Added support for: <ul style="list-style-type: none"> AX140405, J1939-CANopen-ModbusRTU Converter; AX140202, J1939-CANopen-ModbusRTU Converter.
4.5.55	September 3, 2013	Gustavo Del Valle	Added support for: <ul style="list-style-type: none"> AX140402, J1939, CANopen, J1587 Converter; AX140403, J1939, CANopen, J1587 Converter.
4.5.53	August 23, 2013	Gustavo Del Valle	Added support for: <ul style="list-style-type: none"> AX181000, 4 TC, 7 Analog, 3 Universal Inputs; AX140501, PLC to J1939 Protocol Converter. AX140201, J1939, CANopen, J1587 Converter. Updated Acronyms section (OB).
4.5.50	July 16, 2013	Olek Bogush	Added support for a customer-specific BLDC Motor Control. Changed AX022310 from AX022310, CAN with Dual 3A, to AX022310, CAN with Dual 2.5A Outputs, Plug-In.
4.5.49	June 11, 2013	Olek Bogush	Added support for: <ul style="list-style-type: none"> AX140400, J1939, J1939, J1587 Converter; AX140401, J1939, J1939, J1587 Converter. Removed Acronym column from the <i>List of Supported Axiomatic ECUs in Appendix B</i> .
4.5.47	May 27, 2013	Olek Bogush	Added support for a customer-specific DIO module.
4.5.46	April 19, 2013	Olek Bogush	Added ECUID (PGN 64965) field in the General ECU Information group. Added support for a customer-specific ECU.
4.4.45	April 11, 2013	Olek Bogush	Added support for a customer-specific Eight Channel RTD Scanner.
4.4.44	March 25, 2013	Olek Bogush	Added support for: <ul style="list-style-type: none"> AX140200, J1939-CANopen-ModbusRTU Converter; AX130601, J1772 Compliant Wake on Charge Module. Significantly changed support for: <ul style="list-style-type: none"> AX140100, J1939-J1939-ModbusRTU Converter, named previously: CAN to RS-485 Converter.

UM Version	Date	Author	Modifications
			Added pretty-print text formatting to .xml setpoint files eliminating the need for text files with the same information.
4.4.42	December 12, 2012	Olek Bogush	Added support for 1MBit/s baud rate. Referred to 500 kbit/s baud rate as one defined by J1939/14.
4.3.42	October 2, 2012	Anna Murray	Added support for: <ul style="list-style-type: none"> AX140100, CAN to RS-485 Converter
4.3.41	September 10, 2012	Olek Bogush	Added support for multiple baud rates to EA. Updated UM with this feature.
4.2.41	August 29, 2012	Anna Murray	Updated version number of UM to match the latest release of EA. Revised the wire colors on CAB-AX070501.
4.2.40	July 4, 2012	Anna Murray	Changed part number AX06020x to J1939 CAN Inclinator with Additional Outputs. Added new part number AX06040x and called it J1939 CAN Inclinator.
4.2.39	June 7, 2012	Anna Murray	Changed part number AX022410 to AX022020, CAN with Dual 3A Outputs, Side Connect. Added support for: <ul style="list-style-type: none"> AX022410, Dual Input, Dual Output, Side Connect. Updated support for: <ul style="list-style-type: none"> AX022400 to Dual Input, Dual Output, Top Connect.
4.2.38	April 20, 2012	Anna Murray	Added support for controllers: <ul style="list-style-type: none"> AX022002, CAN with Dual 3A Outputs, Top Connect; AX022310, CAN with Dual 3A Outputs, Plug-In; AX022410, CAN with Dual 3A Outputs, Side Connect.
4.2.37	April 13, 2012	Anna Murray	Added explanation of .txt file that is now created in parallel with the .xml file when setpoints are saved.
4.1.37	March 23, 2012	Olek Bogush	Added support for: <ul style="list-style-type: none"> AX022800, Positional Valve Driver.
4.1.36	February 9, 2012	Anna Murray	Added support for: <ul style="list-style-type: none"> AX130500, Dual Input, Dual Output Signal Controller. Updated References section. Updated footer on the cover page.
4.1.35	October 27, 2011	Olek Bogush	In the <i>J1939 Bootloader</i> section renamed application software to application firmware. <i>Flashing New Application Firmware</i> subsection was rewritten. Figure numbering format was changed.
4.0.35	September 29, 2011	Olek Bogush	UM was fully rewritten and reformatted. Most sections were updated. Added support for the <i>J1939 Bootloader</i> .
3.0.35	May 6, 2011	Anna Murray	Added support for: <ul style="list-style-type: none"> AX022400, Dual Input, Dual Output Valve Driver. Updated References section.
3.0.34	Dec 10, 2010	Olek Bogush	Added support for: <ul style="list-style-type: none"> AX100600, 5A Motor Controller. Updated References section.
3.0.33	May 26, 2010	Anna Murray	Added support for: <ul style="list-style-type: none"> AX100700, 2A Stepper Motor Drive.

UM Version	Date	Author	Modifications
3.0.32	May 18, 2010	Olek Bogush	Added support for: <ul style="list-style-type: none"> AX021810, 4IN-2OUT Control without voltage references. Changed footnotes to reflect the product P/N.
3.0.31	Jan 5, 2010	Olek Bogush	Added support for: <ul style="list-style-type: none"> AX030530, 1 Analog Signal Input CAN Controller.
3.0.30	Dec 22, 2009	Olek Bogush	Added support for: <ul style="list-style-type: none"> AX022200, Single Valve Controller.
3.0.29	Oct 19, 2009	Olek Bogush	Added support for: <ul style="list-style-type: none"> AX030520, 1 Analog Signal Output CAN Controller.
3.0.28.0	Aug 6, 2009	Anna Murray	Added support for: <ul style="list-style-type: none"> AX100000, 150A Motor Controller. Updated Appendix B so that descriptions match what is in EA.
3.0.27.0	Aug 5, 2009	Olek Bogush	Added support for: <ul style="list-style-type: none"> AX030500, 4 Analog Signal Output CAN Controller.
3.0.26.0	May 27, 2009	Anna Murray	Removed all references to EA behavior with regard to previous installation automatic removal. Added support for: <ul style="list-style-type: none"> AX021900, 8 Input, 5 Output.
3.0.25b	May 13, 2009	Anna Murray	Updated UM to reflect the fact the EA will no longer require manual uninstallation when a newer version is loaded. From EA 3.0.25.2.
3.0.25	April 9, 2009	Anna Murray	Added support for: <ul style="list-style-type: none"> AX090300, 5A Solar Charger.
3.0.24	March 23, 2009	Olek Bogush	Added support for: <ul style="list-style-type: none"> AX060200 J1939 CAN Inclinator.
3.0.23	February 2, 2009	Olek Bogush	Added support for: <ul style="list-style-type: none"> AX022000 1IN-2OUT Control.
3.0.20	September 12, 2008	Olek Bogush	Added support for: <ul style="list-style-type: none"> AX021800 4IN-2OUT Control. Removal of the old version of EA was suppressed during installation.
3.0.19	July 25, 2008	Olek Bogush	Added support for: <ul style="list-style-type: none"> AX100100, Motor Control.
3.0.16	May 21, 2008	Anna Murray	Added support for: <ul style="list-style-type: none"> AX030300, 18 Digital Input and AX100050, 150A Motor Speed Controller. Removed references to AX100000 and AX100100 Motor Controllers.
3.0.15	April 3, 2008	Anna Murray	Added support for: <ul style="list-style-type: none"> AXTC20, Twenty Thermocouple Scanner.
3.0.13	Feb. 8, 2008	Olek Bogush	Added support for: <ul style="list-style-type: none"> AX021600, Single Channel CAN Controller, Universal Input, 2A Output.
3.0.12	Jan. 30, 2008	A. Wilkins	Marketing Review – Added TM, EA Logo and name change to Electronic Assistant.

UM Version	Date	Author	Modifications
2.0.12	September 11, 2007	Olek Bogush	Added support for: <ul style="list-style-type: none"> AX09000x, 10A Battery Charger ECU.
2.0.11	August 31, 2007	A. Wilkins Olek Bogush	The software was renamed to <i>Axiomatic Electronic Assistant</i> . Reviewed the user manual. Changed the European office address. Added the <i>USB-CAN Converter</i> paragraph.
1.4.11	May 23, 2007	Olek Bogush	Added Support for <i>Software ID</i> (PGN 65242). <i>General NAME</i> Information pane was replaced with <i>General ECU Information</i> pane, which includes <i>ECU Name</i> , <i>Address</i> , and <i>Software ID</i> . Improved presentation of the <i>ECU Setpoint</i> files.
1.3.11	May 3, 2007	Olek Bogush	Added <i>User Manual Help</i> menu item, which is activated by pressing F1. Installation package was changed the way that it now automatically removes an old EA version during installation. <i>Version History</i> chapter was changed to reflect this feature.
1.2.11	April 24, 2007	Olek Bogush	Added support for: <ul style="list-style-type: none"> AX100200, BLDC Motor Drive (12V/24VDC, 25A).
1.2.10	March 13, 2007	Olek Bogush	Added ECU UTC-BLDC-DRV Support. Added new <i>ECU Instance Setup Dialog</i> in multiple instances of the same ECU on Bus. Added some changes to <i>Writing a Setpoint File Group</i> . Added changes in <i>Saving and Flashing a Setpoint File</i> .
1.2.9	January 22, 2007	Anna Murray	Added ECU TC4 support.
1.2.8	December 18, 2006	Anna Murray	Added ECU AX100100 support.
1.2.7	November 21, 2006	Anna Murray	Added system requirements to the user manual. New module supported; EA updated for initial release. Better screen capture of network ECUs
1.2.6	November 3, 2006	Anna Murray	Initial Draft of the user manual.



A correct user manual (UM) should be used for each EA version number. Three most significant (leftmost) numbers of the EA version number determine the valid UM version for that EA. The least significant (rightmost) number of the EA version number is used for small updates in EA, which do not affect the UM contents. For example, EA V4.1.35.0 and EA V4.1.35.1 use the same UM V4.1.35.

If the UM contents have to be changed for the same EA version, a letter is added to the UM version number. For example, if the UM V3.0.35 requires updates due to some discrepancies or for any other reason, the new UM version will be 3.0.35A (or 3.0.35a), then 3.0.35B (or 3.0.35b), etc. The letters are not case sensitive, but capital letters are preferred.

OUR PRODUCTS

AC/DC Power Supplies
Actuator Controls/Interfaces
Automotive Ethernet Converters
Battery Chargers
CAN Controls, Routers, Repeaters
CAN/WiFi, CAN/Bluetooth, Routers
Current/Voltage Converters
DC/DC Power Converters
Engine Temperature Scanners
Ethernet/CAN Converters,
Gateways, Switches
Fan Drive Controllers
Gateways, CAN/Modbus Protocols
Gyroscope Inclinometers
Hydraulic Valve Controllers
Inclinometers, Triaxial
I/O Controls
LVDT Signal Converters
Machine Controls
Modbus Controls
Motor Controls
Power Supplies, DC/DC, AC/DC
PWM Signal Converters/Isolators
Resolver Signal Conditioners
Service Tools
Signal Conditioners, Converters
Strain Gauge CAN Controls
Surge Suppressors

OUR COMPANY

Axiomatic provides electronic machine control components to the off-highway, commercial vehicle, electric vehicle, power generator set, material handling, renewable energy and industrial OEM markets. ***We innovate with engineered and off-the-shelf machine controls that add value for our customers.***

QUALITY DESIGN AND MANUFACTURING

We have an ISO9001:2015 registered design/manufacturing facility in Canada.

WARRANTY, APPLICATION APPROVALS/LIMITATIONS

Axiomatic Technologies Corporation reserves the right to make corrections, modifications, enhancements, improvements, and other changes to its products and services at any time and to discontinue any product or service without notice. Customers should obtain the latest relevant information before placing orders and should verify that such information is current and complete. Users should satisfy themselves that the product is suitable for use in the intended application. All our products carry a limited warranty against defects in material and workmanship. Please refer to our Warranty, Application Approvals/Limitations and Return Materials Process at <https://www.axiomatic.com/service/>.

COMPLIANCE

Product compliance details can be found in the product literature and/or on axiomatic.com. Any inquiries should be sent to sales@axiomatic.com.

SAFE USE

All products should be serviced by Axiomatic. Do not open the product and perform the service yourself.



This product can expose you to chemicals which are known in the State of California, USA to cause cancer and reproductive harm. For more information go to www.P65Warnings.ca.gov.

SERVICE

All products to be returned to Axiomatic require a Return Materials Authorization Number (RMA#) from sales@axiomatic.com. Please provide the following information when requesting an RMA number:

- Serial number, part number
- Runtime hours, description of problem
- Wiring set up diagram, application and other comments as needed

DISPOSAL

Axiomatic products are electronic waste. Please follow your local environmental waste and recycling laws, regulations and policies for safe disposal or recycling of electronic waste.

CONTACTS

Axiomatic Technologies Corporation
5915 Wallace Street
Mississauga, ON
CANADA L4Z 1Z8
TEL: +1 905 602 9270
FAX: +1 905 602 9279
www.axiomatic.com
sales@axiomatic.com

Axiomatic Technologies Oy
Höytämöntie 6
33880 Lempäälä
FINLAND
TEL: +358 103 375 750
FAX: +358 3 3595 660
www.axiomatic.com
salesfinland@axiomatic.com