

BLDC MOTOR CONTROLLER

With CANopen®

USER MANUAL

P/N: AX100261

VERSION HISTORY

Version	Date	Author	Modification
1.0.0.	Feb 8, 2019	Antti Keränen	Initial Draft
1.0.1.	Feb 12, 2019	Antti Keränen	Updates in sections 1.1 and 1.6. Section 3 renamed.

ACRONYMS

BATT +/-	Battery positive (a.k.a. Vps) or Battery Negative (a.k.a. GND)
DIN	Digital Input used to measure active high or low signals
EMCY	Diagnostic Message (from CANopen standard)
EA	Electronic Assistant [®] , p/n AX070502 (A Service Tool for Axiomatic ECUs)
ECU	Electronic Control Unit (from SAE J1939 standard)
GND	Ground reference (a.k.a. BATT-)
I/O	Inputs and Outputs
PWM	Pulse Width Modulation
RPM	Rotations per Minute
UIN	Universal input used to measure voltage, current, frequency or digital inputs
Vps	Voltage Power Supply (a.k.a. BATT+)
%dc	Percent Duty Cycle (Measured from a PWM input)

TABLE OF CONTENTS

1.1.	BLDC Motor Control Functionality	9
1.2.	CANopen PDS FSA.....	13
1.3.	Inverter (Texas Instruments DRV8301).....	14
1.4.	Input Function Blocks	14
1.5.	PID Controller Block	22
1.6.	Diagnostics	24
1.7.	Control Logic Block.....	24
1.8.	Miscellaneous Function Block	27
1.9.	Available Control Sources	28
2.1.	Dimensions and Pinout.....	30
3.1.	Node ID and Baud rate	31
3.1.1.	LSS Protocol to Update	31
3.2.	Communication Objects (DS-301).....	35
3.2.1.	1000h Device Type.....	36
3.2.2.	1001h Error Register	36
3.2.3.	1002h Manufacturer Status Object.....	36
3.2.4.	1003h Pre-Defined Error Field.....	36
3.2.5.	1010h Store Parameters.....	36
3.2.6.	1011h Restore Parameters	37
3.2.7.	1016h Consumer Heartbeat Time	37
3.2.8.	1017h Producer Heartbeat Time	37
3.2.9.	1018h Identity Object.....	37
3.2.10.	1020h Verify Configuration	37
3.2.11.	1029h Error Behavior.....	38
3.2.12.	1400h RPDO 1 Communication Parameters.....	38
3.2.13.	1401h RPDO 2 Communication Parameters.....	38
3.2.14.	1402h RPDO 3 Communication Parameters.....	38
3.2.15.	1403h RPDO 4 Communication Parameters.....	38
3.2.16.	1600h RPDO 1 Mapping Parameters.....	39
3.2.17.	1601h RPDO 2 Mapping Parameters.....	39
3.2.18.	1602h RPDO 3 Mapping Parameters.....	39
3.2.19.	1603h RPDO 4 Mapping Parameters.....	39
3.2.20.	1800h TPDO 1 Communication Parameters	39
3.2.21.	1801h TPDO 2 Communication Parameters	40
3.2.22.	1802h TPDO 3 Communication Parameters	40
3.2.23.	1803h TPDO 4 Communication Parameters	40
3.2.24.	1A00h TPDO 1 Mapping Parameters.....	40
3.2.25.	1A01h TPDO 2 Mapping Parameters.....	40
3.2.26.	1A02h TPDO 3 Mapping Parameters.....	41
3.2.27.	1A03h TPDO 4 Mapping Parameters.....	41

3.3. Application Objects (DS-402 Motor Control and DS-404 Inputs & PID)..... 42

3.4. Manufacturer Objects 49

APPENDIX A - TECHNICAL SPECIFICATION.....A-1

Table 1: Commutation sequence, version 1	11
Table 2: Commutation sequence, version 2	11
Table 3: Commutation sequence, version 3	11
Table 4: Commutation sequence, version 4	11
Table 5: Commutation sequence, version 5	11
Table 6: Commutation sequence, version 6	11
Table 7 – DRV8301 Overcurrent adjustment	14
Table 8 – DI Pullup/Down Options	14
Table 9 – Object 6002h DI Polarity 8 Input Lines Options	15
Table 10 – Object 6112h - AI Operating Mode Options	18
Table 11 – Object 6110h - AI Sensor Type Options.....	18
Table 12 – AI Input Range Options Depending on Sensor Type	18
Table 13 – Object 61A0h - AI Filter Type Options.....	19
Table 14 – AI Object Defaults Based on Sensor Type and Input Range	20
Table 15 – AI Object Ranges Based on Sensor Type and Input Range.....	21
Table 16 – PID Response Options	23
Table 17 – EMCY codes.....	24
Table 18 – Math/Enable function to use Options	25
Table 19 – Available Control Sources and Numbers	29
Table 20 – AX100261 Connector Pinout.....	30
Table 21 – LSS Baud rate Indices.....	33

Figure 1 – AX100261 Block Diagram 9

Figure 2 - Sensorless drive startup steps 12

Figure 3 – CANopen PDS FSA and Motor Control Objects 13

Figure 4 – Digital Input Objects 14

Figure 5 – Discrete Input Hysteresis 15

Figure 6 – Analog Input Reads as Digital 16

Figure 7 – Quadrature Decoder Input Objects 17

Figure 8 – Analog Input Objects 17

Figure 9 – Analog Input Linear Scaling FV to PV 20

Figure 10 – PID Control Objects 22

Figure 11 – Control Logic block diagram 24

Figure 12 – Special data available in Control Logic Data 26

Figure 13 – Miscellaneous Objects 27

Figure 14 – AX100261 Dimensional Drawing 30

REFERENCES

- TDAX100260 Technical Datasheet, BLDC Motor Controller with CAN, Axiomatic Technologies 2016
- UMAX07050x User Manual V4.10.77, Electronic Assistant and USB-CAN, Axiomatic Technologies, July 2015
- SLOS719 Datasheet for Three Phase Pre-Driver with Dual Current Shunt Amplifiers and Buck Regulator, DRV8301, Texas Instruments, August 2011

1. OVERVIEW OF CONTROLLER

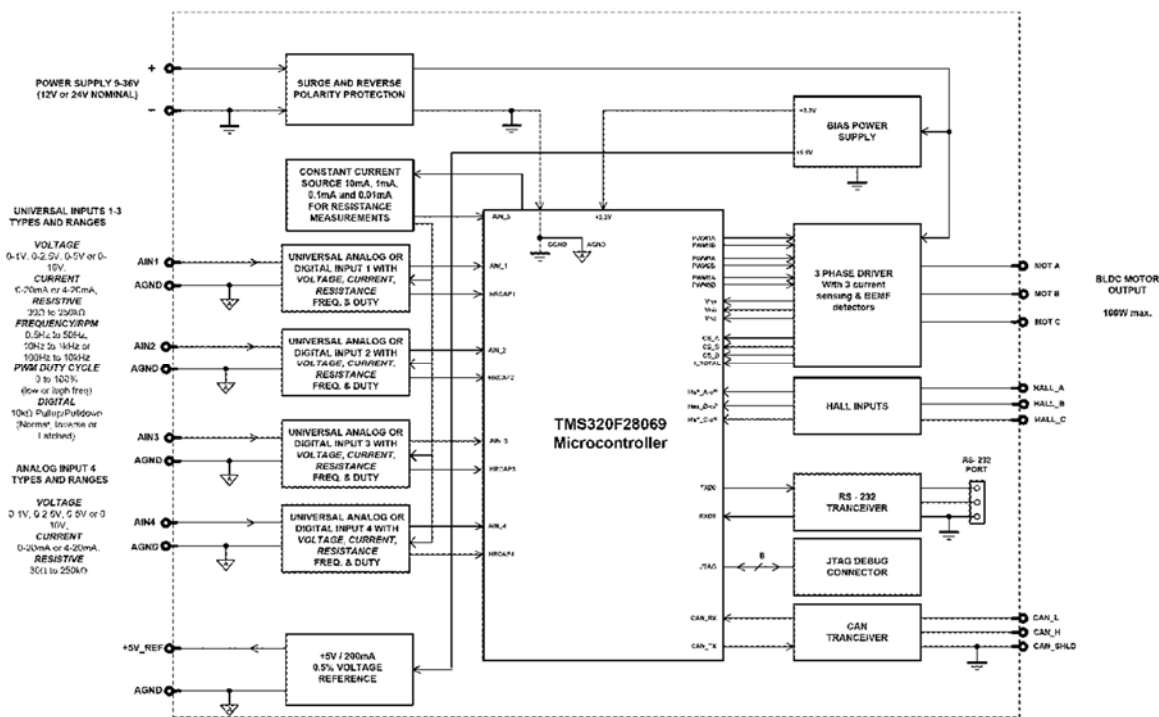

Figure 1 – AX100261 Block Diagram

The BLDC Motor Controller has three Universal Inputs that can be configured to measure voltage, current, frequency, PWM duty cycle, resistance or digital voltage level (on/off). A fourth Analog Input accepts voltage, current or resistive input types. Measured input data can be sent to a CANopen CAN Network as is or used in the BLDC controller function blocks for controlling how the BLDC motor is driven.

All CANopen objects supported by the AX100261 are user configurable using standard commercially available tools that can interact with a CANopen® Object Dictionary via an .EDS file.

1.1. BLDC Motor Control Functionality

The 6A BLDC Controller can drive brushless DC motors equipped with Hall sensors. Also sensorless motor control using Back-EMF rotor position detection is supported. There are multiple CANopen objects that allow the user to configure the 6A BLDC controller to drive a variety of different BLDC motors.

The Motor Parameters (manufacturer objects starting from 3.4.14 and application objects starting from 3.3.22) supports the configuration of the main motor parameters, such as number of pole pairs, rotor position detection, rated RPM of the motor, PWM frequency to use in Motor Phase drive, commutation sequence to use (Hall sensor method only) and whether to use HW current protection.

3510h **Number of pole pairs** has direct influence on how the 6A BLDC Controller picks up the motor RPM, this parameter should be always set to correspond the motor driven by the controller.

The 6080h **Max Motor Speed** object is used for normalizing the RPM data in the function blocks. It does not have other influence how the motor is driven by the controller.

The 3515h **PWM Frequency** sets the frequency to use in the Phase outputs' PWM signal.

In case the over current protection gets triggered, the 3513h **Over current event clear time** specifies the time in milliseconds after which the controller clears the over current status and resumes normal operation. The hardware over current limit is set to 12A. If the event clear time is set to 0ms, the over current status won't be cleared (a power cycle is required to resume normal operation).

1.1.1. Hall Sensor Based Control

Hall sensor based control implements six different commutation schemes. It is on the user's responsibility to select the proper one for the motor in question.

The Hall sensor input pins (Hall A / Gray-10, Hall B / Gray-3, Hall C / Gray-11, see section 2.1) have an internal 1k Ω pull-up resistor to Hall 5V pin. The Hall signal is expected to be a 0-5V square wave.

The Hall 5V (Gray-4) can be used for powering the Hall sensors.

Hall C	Hall B	Hall A	Phase A	Phase B	Phase C
1	0	1	LOW	OFF	PWM
0	0	1	OFF	LOW	PWM
0	1	1	PWM	LOW	OFF
0	1	0	PWM	OFF	LOW
1	1	0	OFF	PWM	LOW
1	0	0	LOW	PWM	OFF

Table 1: Commutation sequence, version 1

Hall C	Hall B	Hall A	Phase A	Phase B	Phase C
1	0	1	OFF	LOW	PWM
0	0	1	PWM	LOW	OFF
0	1	1	PWM	OFF	LOW
0	1	0	OFF	PWM	LOW
1	1	0	LOW	PWM	OFF
1	0	0	LOW	OFF	PWM

Table 2: Commutation sequence, version 2

Hall C	Hall B	Hall A	Phase A	Phase B	Phase C
1	0	1	PWM	LOW	OFF
0	0	1	PWM	OFF	LOW
0	1	1	OFF	PWM	LOW
0	1	0	LOW	PWM	OFF
1	1	0	LOW	OFF	PWM
1	0	0	OFF	LOW	PWM

Table 3: Commutation sequence, version 3

Hall C	Hall B	Hall A	Phase A	Phase B	Phase C
1	0	1	PWM	OFF	LOW
0	0	1	OFF	PWM	LOW
0	1	1	LOW	PWM	OFF
0	1	0	LOW	OFF	PWM
1	1	0	OFF	LOW	PWM
1	0	0	PWM	LOW	OFF

Table 4: Commutation sequence, version 4

Hall C	Hall B	Hall A	Phase A	Phase B	Phase C
1	0	1	OFF	PWM	LOW
0	0	1	LOW	PWM	OFF
0	1	1	LOW	OFF	PWM
0	1	0	OFF	LOW	PWM
1	1	0	PWM	LOW	OFF
1	0	0	PWM	OFF	LOW

Table 5: Commutation sequence, version 5

Hall C	Hall B	Hall A	Phase A	Phase B	Phase C
1	0	1	LOW	PWM	OFF
0	0	1	LOW	OFF	PWM
0	1	1	OFF	LOW	PWM
0	1	0	PWM	LOW	OFF
1	1	0	PWM	OFF	LOW
1	0	0	OFF	PWM	LOW

Table 6: Commutation sequence, version 6

1.1.2. Sensorless Control

The sensorless motor control is based on detecting the Back EMF voltage on the free phase while the motor is running. While this voltage is available only when the motor is running, the startup procedure is carried out without knowing whether the rotor rotates or not. Depending on the motor in question, the user must tune the startup parameters accordingly (see section 3.4).

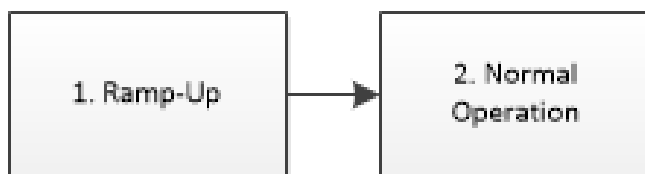

Figure 2 - Sensorless drive startup steps

The sensorless startup is carried out in two steps, namely:

1. Ramp-Up

During the ramp-up period, the motor is driven in open loop configuration for picking up speed and for making the Back EMF signals available for the sensorless control. The speed of the ramp up, together with initial and target commutation speed are user configurable. The PWM drive during this phase is defined by what is configured in 3716h **Initial Maximum PWM Drive** object. The 3715h **Startup Period Setpoint** defines the commutation interval in the start of the ramp up phase. The 3714h **Startup Period Target** defines the commutation interval in the end of the ramp up phase. The unit value for these setpoints is 25us. The 3713h **Output PWM Ramp Time** defines how fast the ramp is decremented (i.e. commutation is sped up).

The ramp-up phase duration is determined by the following formula, in which 40kHz is the fixed execution speed of the low level commutation algorithm.

$$t_{\text{ramp-up}} = \frac{((\text{Startup Period Setpoint} - \text{Startup Period Target}) * \text{Output PWM Ramp Time})}{40\text{kHz}}$$

With default settings, the ramp-up phase duration is 312ms.

2. Normal Operation

After the ramp-up is done, the rotor should be rotating. At this point the controller switches over to normal operation in which the rotor position is picked up by the Back-EMF algorithm and the PWM drive signals are applied accordingly. In this mode the motor driving signals' PWM duty cycle is determined by the Speed and/or Current controller, as configured.

When sensorless control is used, the firmware provides an option to measure the motor RPM using Hall A signal instead of measuring it using the Back EMF. If this style of RPM measurement is required, the 3514h **RPM pickup style** setpoint should be set to *1 – Use Hall A*.

1.2. CANopen PDS FSA

The firmware implements CANopen PDS FSA for controlling the motor. The details of the PDS FSA is described in **CiA 402: Drives and motion control device profile**. This section describes only the main points. The inputs to the PDS FSA are controlled using manufacturer objects for implementing more control options.

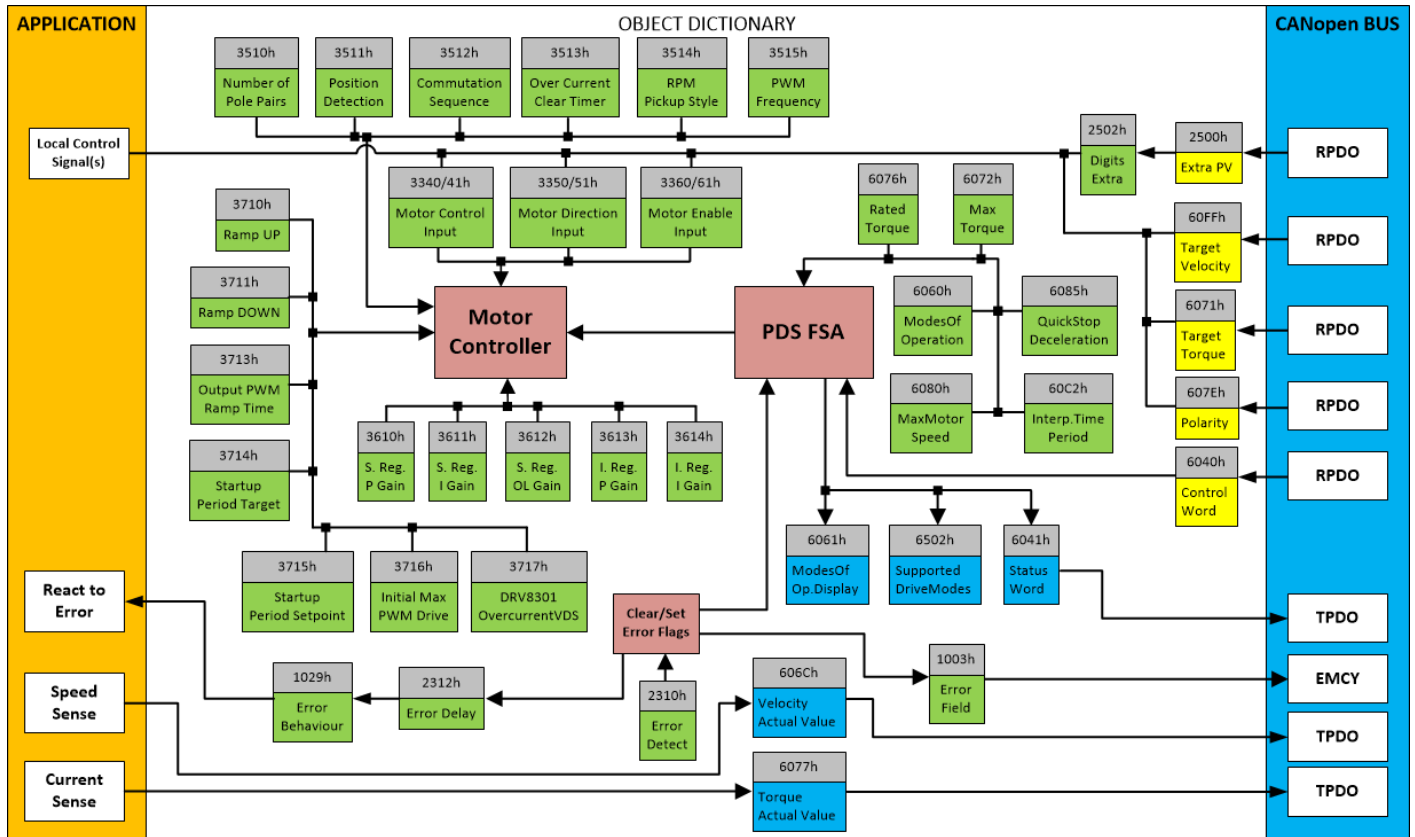

Figure 3 – CANopen PDS FSA and Motor Control Objects

The top-level motor control is handled by the PDS FSA block. It handles the enabling and disabling the motor drive based on the received CANopen messages.

The lower level motor control, including the speed and current (torque) control loops and the startup procedure in the sensorless mode is taken care by the Motor Controller block. This level of control receives the commands from the PDS FSA and works accordingly.

The actual control, direction and enable sources for the Motor Controller block are user configurable. While the master enable signal comes from the PDS FSA, the speed, enable and direction control can be also read from the Universal Inputs of the AX100261.

The objects 3340h **Motor Control Input Source** and 3341h **Motor Control Input Number** select the motor speed (rpm) control source, 3350h **Motor Direction Input Source** and 3351h **Motor Direction Input Number** select the direction signal source and 3360h **Motor Enable Input Source** and 3361h **Motor Enable Input Number** select an optional enable signal. However, it must be noted that the PDS FSA sets the master enable.

1.3. Inverter (Texas Instruments DRV8301)

The 6A BLDC Controller uses Texas Instruments DRV8301 chip to generate driving signals for the output FETs. The motor over current detection is handled by the DRV8301 chip measuring the Vds voltage of the output FETs. The available user configurable settings for 3717h **Overcurrent Vds** are listed in Table 7. In Table 7, the Vds values are from DRV8301 datasheet SLOS719 and (Max current) Ids values are calculated using IRFR1018E datasheet.

Configuration option	0	1	2	3	4
Vds	0.060V	0.068V	0.076V	0.086V	0.097V
Max current	7.1A	8.1A	9.0A	10.2A	11.5A

Table 7 – DRV8301 Overcurrent adjustment

1.4. Input Function Blocks

1.4.1. Digital Input Modes

The digital input (DI) function block only becomes applicable on the input when object 6112h **AI Operation**, is set to a digital input response.

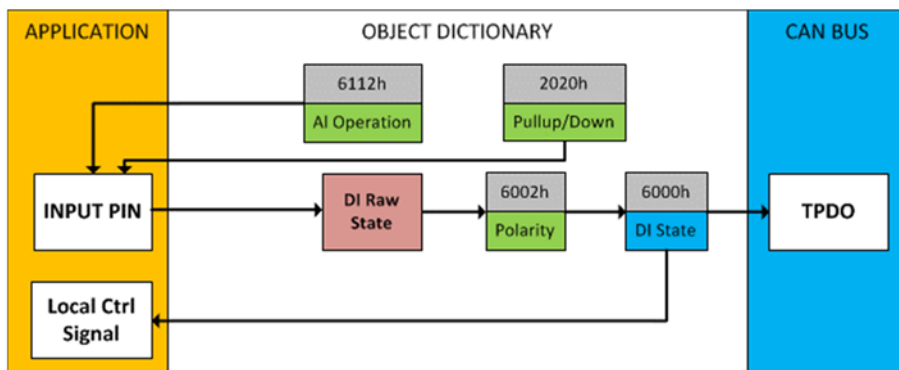

Figure 4 – Digital Input Objects

When object 6112h is set to 10 = *Digital Input*, object 2020h **DI Pull-up/Pull-down Mode** will determine the configuration of the internal Pull-up/Pull-down resistors. The options for object 2020h are shown in Table 8, with the default bolded.

Value	Meaning
0	Pullup/Down Disabled (high impedance input)
1	10kΩ Pullup Resistor Enabled
2	10kΩ Pulldown Resistor Enabled

Table 8 – DI Pullup/Down Options

Figure 5 shows the hysteresis on the input when switching a discrete signal. A digital input can be switched up to +Vcc

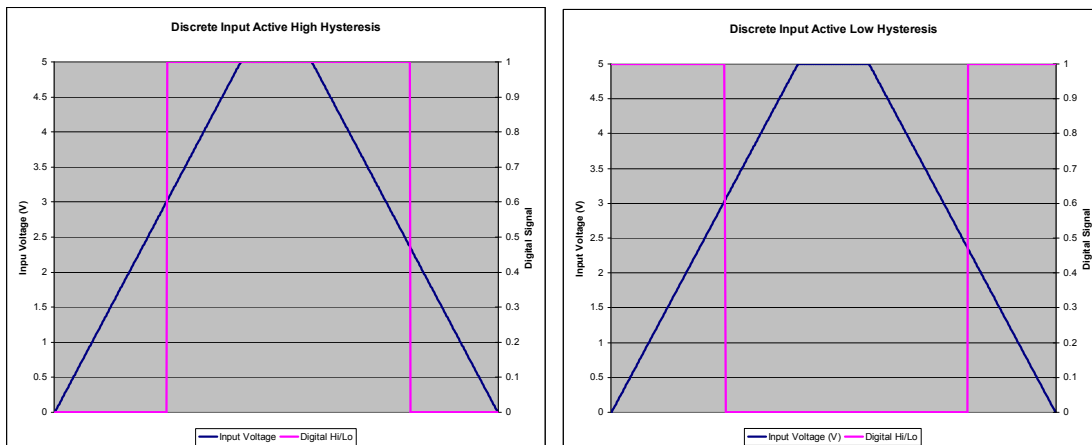

Figure 5 – Discrete Input Hysteresis

Once the raw state has been evaluated, the logical state of the input is determined by object 6002h **DI_Polarity_8_Input_Lines**. The options for object 6002h are shown in Table 9. The state of the DI will be written to read-only object 6000h **DI_Read_state_8_Input_Lines**. By default, normal on/off logic is used.

Value	Meaning
0	Normal On/Off
1	Inverse On/Off

Table 9 – Object 6002h DI Polarity 8 Input Lines Options

The format to write to object 6002h is as follows:

Sub-index 1 will determine the following inputs polarities

Bit 7	Bit 6	Bit 5	Bit 4	Bit 3	Bit 2	Bit 1	Bit 0
-	-	-	-	-	-	UI2	UI1

The rest of the bits in sub-index 1 will be ignored.

As per the format of object 6002h, the bits in object 6000h **DI_Read_state_8_Input_Lines** will be written to represent the same inputs' states.

There is another type of 'digital' input that can be selected when 6112h is set to 20 = Analog On/Off. However, in this case, the input is still configured as an analog input, and therefore the objects from the Analog Input (AI) block are applied instead of those discussed above. Here, objects 2020h, 2030h and 6030h are ignored, and 6000h is written as per the logic shown in Figure 6. In this case, the MIN parameter is set by object 7120h **AI Scaling 1 FV**, and the MAX is set by 7122h **AI Scaling 2 FV**. For all other operating modes, object 6000h will always be zero.

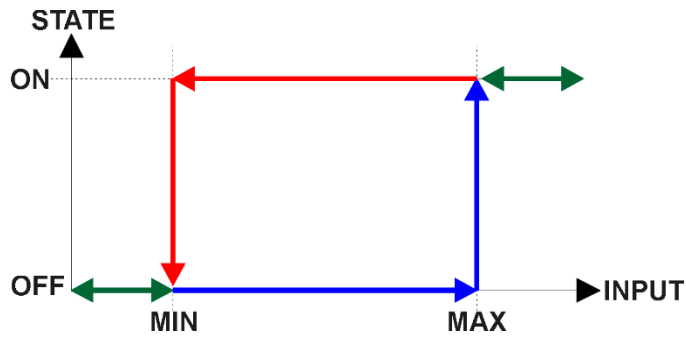

Figure 6 – Analog Input Reads as Digital

1.4.1.1. Quadrature Decoder

AX100261 supports reading a signal generated by a quadrature encoder. For using the quadrature decoder function, Inputs 1 & 2 must be configured to one of the Quadrature Encoder modes. The Input 3 can be used to read in the Index Signal generated by the quadrature encoder, but this is optional.

Input	Function
1	Encoder A
2	Encoder B
3	Encoder Index

The quadrature decoder functionality can be configured using objects 3410h **Quadrature Decoder Scaler**, 3411h **Quadrature Decoder Direction**, 3412h **Quadrature Decoder Offset** and 3413h **Quadrature Decoder Pulses Per Revolution**.

The quadrature decoder results are available in object 7100h Input FV and are processed depending on the Input FV to PV scaling settings.

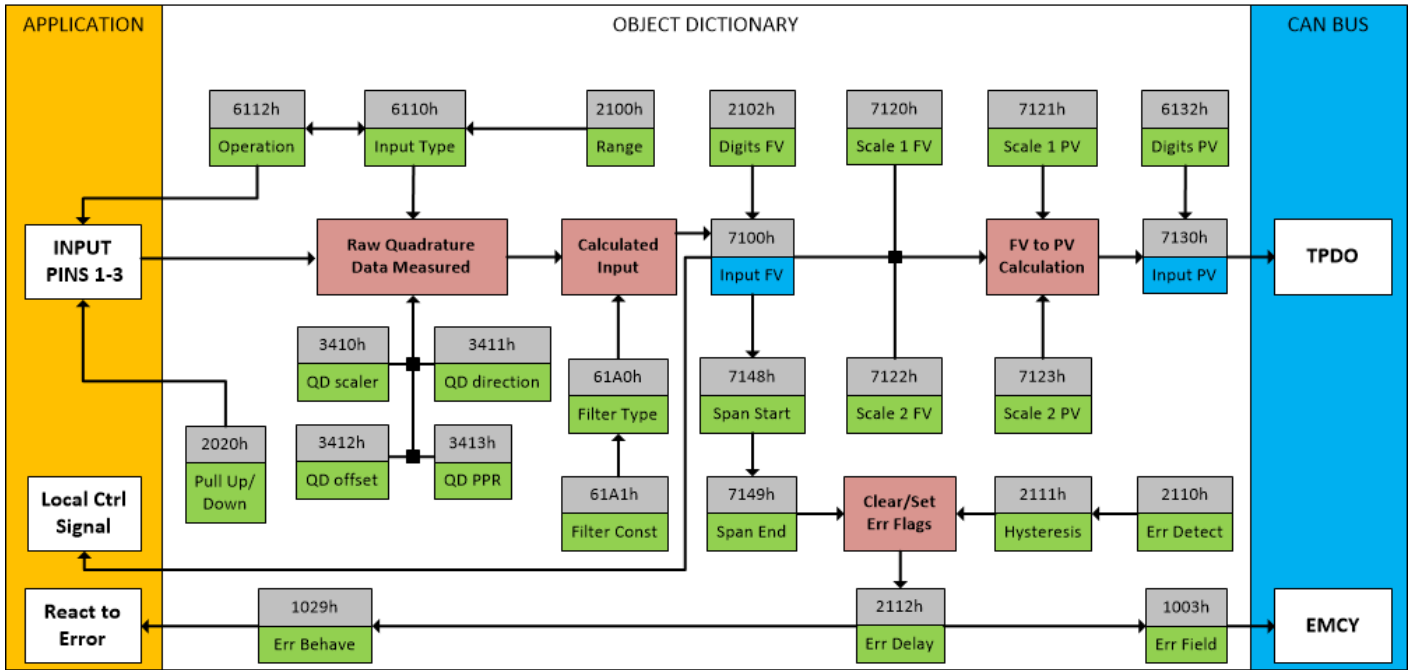

Figure 7 – Quadrature Decoder Input Objects

1.4.2. Analog Input Modes

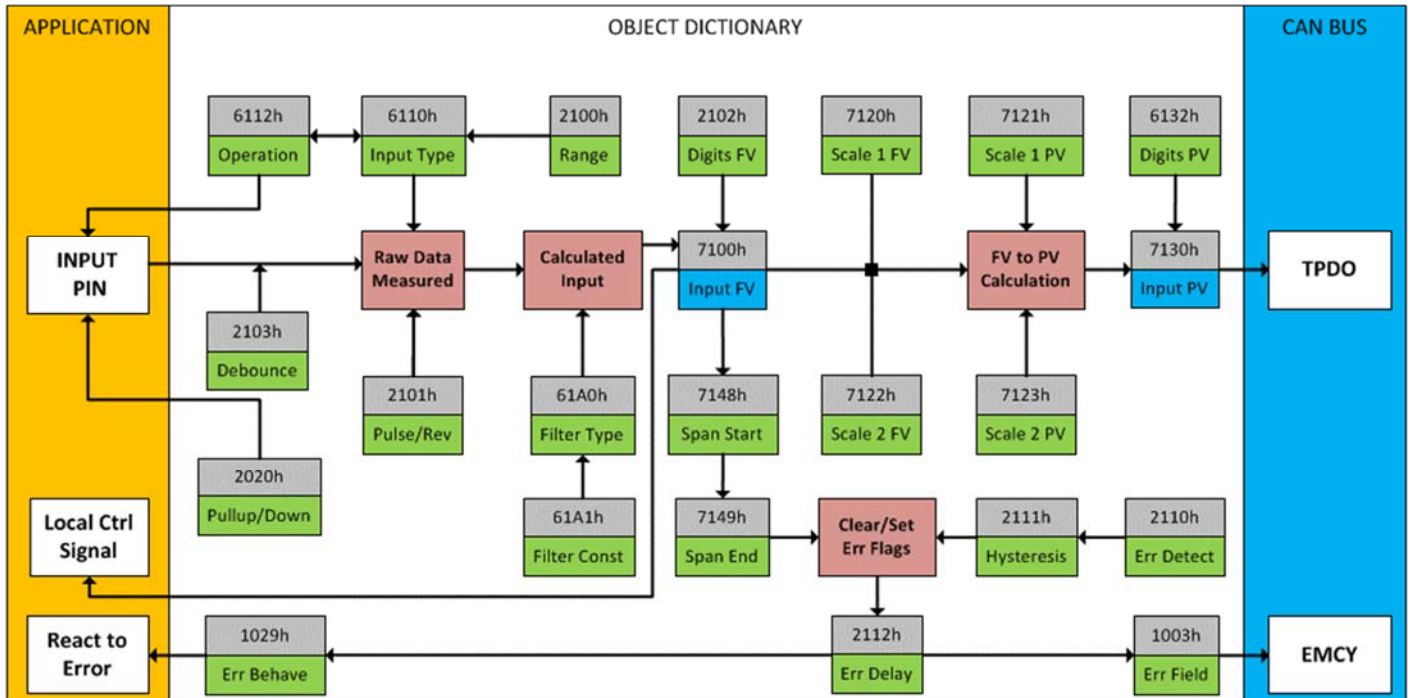

Figure 8 – Analog Input Objects

Object 6112h **AI Operating Mode** determines whether the AI or DI block is associated with an input. The options for object 6112h are shown in Table 10. No values other than what are shown here will be accepted.

Value	Meaning
0	Channel Off
1	Normal Operation (analog)
10	Digital Input (on/off)
20	Analog and On/Off

Table 10 – Object 6112h - AI Operating Mode Options

The most important object associate with the AI function block is object 6110h **AI Sensor Type**. By changing this value, and associated with its object 2100h **AI Input Range**, other objects will be automatically updated by the controller. The options for object 6110h are shown in Table 11, and no values other than what are shown here will be accepted. The inputs are setup to measure voltage by default.

Value	Meaning
40	Voltage Input
50	Current Input
60	Frequency Input (or RPM)
100	Resistive
10000	PWM Input
10002	Quadrature Decoder

Table 11 – Object 6110h - AI Sensor Type Options

The allowable ranges will depend on the input sensor type selected. Table 12 shows the relationship between the sensor type, and the associated range options. The default value for each range is bolded, and object 2100h **AI Range** will automatically be updated with this value when 6110h is changed. The grayed cells mean that the associate value is not allowed for the range object when that sensor type has been selected.

Value	Voltage	Current	Frequency	Resistive	PWM	Quad.Dec
0	0 to 5V	0 to 20mA	0.5Hz to 50Hz	20 Ω to 250 kΩ	Low Freq (<1kHz)	Edge count
1	0 to 10V	4 to 20mA	10Hz to 1kHz		High Freq (>100Hz)	Direction
2			100Hz to 10kHz			Speed

Table 12 – AI Input Range Options Depending on Sensor Type

Objects 2020h **DI Pull-up/Pull-down Mode** and 2101h **AI Number of Pulses per Revolution** are used with frequency and PWM sensor types.

Object 2020h **DI Pull-up/Pull-down Mode** will determine the configuration of the internal Pull-up/Pull-down resistors. The options for object 2020h are shown in Table 8, with the default bolded.

Frequency measurement can be changed to RPM, by setting object 2101h **AI Number of Pulses per Revolution** to a non-zero value.

All inputs can be further filtered once the raw data has been measured. Object 61A0h **AI Filter Type** determines what kind of filter is used per Table 13. By default, additional software filtering is disabled.

Value	Meaning
0	No Filter
1	Moving Average
2	Repeating Average

Table 13 – Object 61A0h - AI Filter Type Options

Object 61A1h **AI Filter Constant** is used with all three types of filters as per the formulas below:

Calculation with no filter:

Value = Input

The data is simply a ‘snapshot’ of the latest value measured by the ADC or timer.

Equation 1 - Moving Average Transfer Function:

$$\text{Value}_N = \text{Value}_{N-1} + \frac{(\text{Input} - \text{Value}_{N-1})}{\text{Filter Constant}}$$

This filter is called every 1ms. The value Filter Constant stored in object 61A1h is 10 by default.

Equation 2 - Repeating Average Transfer Function:

$$\text{Value} = \frac{\sum_0^N \text{Input}_N}{N}$$

At every reading of the input value, it is added to the sum. At every Nth read, the sum is divided by N, and the result is the new input value. The value and counter will be set to zero for the next read. The value of N is stored in object 61A1h and is 10 by default. This filter is called every 1ms.

The value from the filter is shifted according to read-only object 2102h **AI Decimal Digits FV** and then written to read-only object 7100h **AI Input Field Value**.

It is the **AI Input FV** which is used by the application for error detection, and as a control signal for other logic blocks (i.e. output control.) Object 7100h is mappable to a TPDO and is mapped to TPDO1 by default.

Read-only object 7130h **AI Input Process Value** is also mappable. However, the default values for objects 7121h **AI Scaling 1 PV** and 7123h **AI Scaling 2 PV** are set to equal 7120h and 7122h respectively, while object 6132h **AI Decimal Digits PV** is automatically initialize to equal 2102h. This means that the default relationship between the FV and PV is one-to-one, so object 7130h is not mapped to a TPDO by default.

Should a different linear relationship between what is measured versus what is sent to the CANopen bus be desired, objects 6132h, 7121h and 7123h can be changed. The linear relationship profile is shown in Figure 7 below.

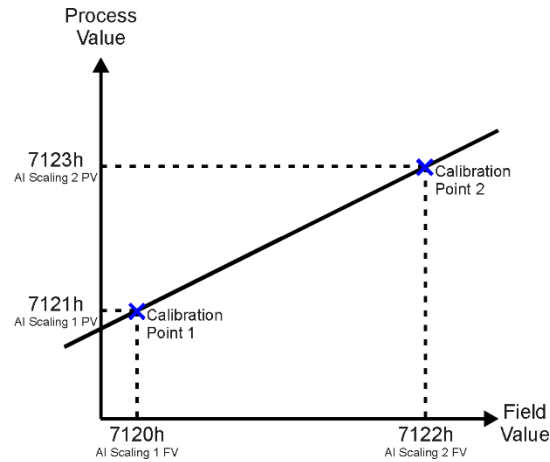

Figure 9 – Analog Input Linear Scaling FV to PV

As stated earlier, the FV scaling objects are automatically updated with the Sensor Type or Range changes. This is because objects 7120h and 7122h are not only used in a linear conversion from FV to PV as described above, but also as the minimum and maximum limits when the input is used to control another logic block. Therefore, the values in these objects are important, even when the AI Input PV object is not being used.

The AI Span Start and AI Span End objects are used for fault detection, so they too are automatically updated for sensible values as the Type/Range changes. The Error Clear Hysteresis object is also updated, as it too is measured in the same unit as the AI Input FV object.

Table 14 lists the default values that are loaded into objects 7120h, 7122h, 7148h, 7149h, and 2111h for each Sensor Type and Pulses per Rev combination. Recall that these objects all have the decimal digits applied to them as outlined in Table 15.

Sensor Type/ Input Range	7148h AI Span Start (i.e. Error Min)	7120h AI Scaling 1 FV (i.e. Input Min)	7122h AI Scaling 2 FV (i.e. Input Max)	7149h AI Span End (i.e. Error Max)	2111h Error Clear Hysteresis
Voltage: 0 to 5V	200 [mV]	500 [mV]	4500 [mV]	4800 [mV]	100 [mV]
Voltage: 0 to 10V	200 [mV]	500 [mV]	9500 [mV]	9800 [mV]	200 [mV]
Current: 0 to 20mA	0 [uA]	0 [uA]	20000 [uA]	20000 [uA]	250 [uA]
Current: 4 to 20mA	1000 [uA]	4000 [uA]	20000 [uA]	21000 [uA]	250 [uA]
Freq: 0.5Hz to 50Hz	100 [0.01Hz]	500 [0.01Hz]	5000 [0.01Hz]	5500 [0.01Hz]	20 [0.01Hz]
Freq: 10Hz to 1kHz	50 [0.1Hz]	100 [0.1Hz]	10000 [0.1Hz]	11000 [0.1Hz]	50 [0.1Hz]
Freq: 100Hz to 10kHz	50 [Hz]	100 [Hz]	10000 [Hz]	10500 [Hz]	10 [Hz]
Freq: RPM Mode	500 [0.1RPM]	1000 [0.1RPM]	30000 [0.1RPM]	33000 [0.1RPM]	100 [0.1RPM]
Resistive	20[0.001kΩ]	30[0.001kΩ]	20000 [0.001kΩ]	25000 [0.001kΩ]	10[0.001kΩ]
PWM: 0 to 100%	10 [0.1%]	50 [0.1%]	950 [0.1%]	990 [0.1%]	10 [0.1%]
Digital Input	OFF	OFF	ON	ON	0
Quadrature Decoder					

Table 14 – AI Object Defaults Based on Sensor Type and Input Range

When changing these objects, Table 15 outlines the range constraints places on each based on the Sensor Type and Input Range combination selected. In all cases, the MAX value is the upper end of the range (i.e. 50000Hz or) Object 7122h cannot be set higher than MAX, whereas 7149h can be set up to 110% of MAX. Object 2111h on the other hand can only be set up to maximum value of 10% of MAX.

Sensor Type/ Pulses per Rev	7148h	7120h	7122h	7149h	2111h
Voltage: 0 to 5V and 0 to 10V Current: 0 to 20mA and 4 to 20mA RPM: 0 to 6000RPM PWM: 0 to 100%	0 to 7120h	7148h to 7122h	7120h to 7149h If(7149h>MAX) 7120h to MAX	7122h to 110% of MAX	10% of MAX
Current: 4 to 20mA	0 to 7120h	7148h to 7122h If(7148h<4mA) 4mA to 7122h			
Freq: 0.5Hz to 50Hz	0.1Hz to 7120h	7148h to 7122h If(7148h<0.5Hz) 0.5Hz to 7122h			
Freq: 10Hz to 1kHz	5Hz to 7120h	7148h to 7122h If(7148h<10Hz) 10Hz to 7122h			
Freq: 100Hz to 10kHz	50Hz to 7120h	7148h to 7122h If(7148h<100Hz) 100Hz to 7122h			
Voltage: 0 to 5V and 0 to 10V Current: 0 to 20mA and 4 to 20mA RPM: 0 to 6000RPM PWM: 0 to 100%	0 to 7120h	7148h to 7122h			

Table 15 – AI Object Ranges Based on Sensor Type and Input Range

The last objects associated with the analog input block left to discuss are those associated with fault detection. Should the calculated input (after measuring and filtering) fall outside of the allowable range, as defined by the AI Span Start and AI Span End objects, an error flag will be set in the application if and only if object 2110h **AI Error Detect Enabled** is set to TRUE (1).

When (7100h AI Input FV < 7148h AI Span Start), an “Out of Range Low” flag is set. If the flag stays active for the 2112h **AI Error Reaction Delay** time, an Input Overload Emergency (EMCY) message will be added to object 1003h **Pre-Defined Error Field**. Similarly, when (7100h AI Input FV > 7149h AI Span End), an “Out of Range High” flag is set and will create an EMCY message should it stay active throughout the delay period. In either case, the application will react to the EMCY message as defined by object 1029h **Error Behavior** at the sub-index corresponding to an Input Fault.

Once the fault has been detected, the associate flag will be cleared only once the input comes back into range. Object 2111h **AI Error Clear Hysteresis** is used here so that the error flag will not be set/cleared continuously while the AI Input FV hovers around the AI Span Start/End value.

To clear an “Out of Range Low” flag, AI Input FV >= (AI Span Start + AI Error Clear Hysteresis)

To clear an “Out of Range High” flag, AI Input FV <= (AI Span End - AI Error Clear Hysteresis)

Both flags cannot be active at once. Setting either one of these flags automatically clears the other.

1.5. PID Controller Block

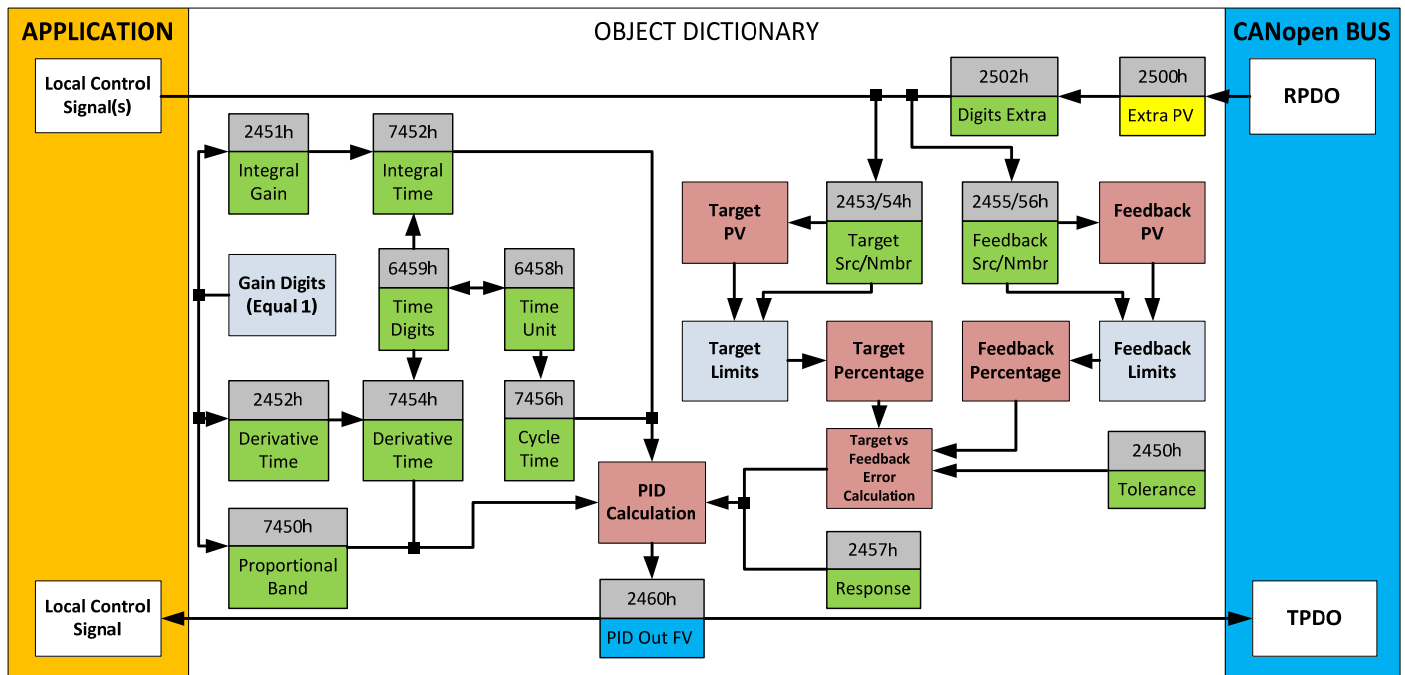

Figure 10 – PID Control Objects

As with the output function block, the PID control function has control inputs associate with it that can be mapped to the output from any other function block. Objects 2453h **PID Target Source** and 2454h **PID Target Number** define what value the PID loop will attempt to maintain. For example, in the case of a setpoint (fixed) control application, this input can be mapped to one of object 5010h, a Constant FV. In this case, since there is no pre-defined range associated with a constant, the scaling limits will be set equal to those of the feedback input. Otherwise, the target input units do not have to match the feedback units, so long as they are scaled relative to one another.

Objects 2355h **PID Feedback Source** and 2356h **PID Feedback Number** define the close-loop input. Both the target and feedback use Table 19 as the available options. Both inputs are normalized to a percentage based on the associated scaling limits.

Object 2450h **PID Tolerance** defines the acceptable difference between the target and feedback, as a percentage, whereby an absolute difference smaller than this is treated as a 0% error.

Unless both the target and feedback inputs have legitimate control sources selected, the PID loop is disabled. When active, however, the PID algorithm will be called every 7456h **PID Cycle Time**, the default being every 10ms.

Object 6458h **PID Physical Unit Timing** is a read-only value and is defined in Seconds. The default value for object 6459h **PID Decimal Digits Timing** is 3, which means the object 7456h, along with other PID timing objects, are interpreted in milliseconds. Other time objects associated with the PID control are 7452h **PID Integral Action Time (Ti)** and 7454h **PID Derivative Action Time (Td)**.

None time related objects use a fixed resolution of 1 decimal digit. These objects include 7450h PID Proportional Band (G), 2450h PID Tolerance, 2451h PID Integral Gain (Ki), and 2454h PID Derivative Gain (Kd).

By default, the PID loop is assumed to be controlling a single output which will increase/decrease as the feedback over/undershoots the target. However, some systems may require a push-pull response where one output comes on when over target, and the other when under. Object 2457h PID Control Response allows the user to select the response profile as needed from Table 16.

0	<i>Single Output</i>
1	<i>Setpoint Control</i>
2	<i>On When Over Target</i>
3	<i>On When Below Target</i>

Table 16 – PID Response Options

The PID algorithm used is shown below, with names in red being the object variables. The result $PIDOutput_k$ is written to the read-only mappable object 2460h **PID Output Field Value** and is interpreted as a percentage value with 1 decimal place resolution. It can be used as the control source for another function block, i.e. one of the analog outputs.

The PID algorithm used is shown below, where G , K_i , T_i , K_d , T_d and $Loop_Update_Rate$ are configurable parameters.

$$PIDOutput_k = P_k + I_k + D_k$$

$$P_k = P_Gain * Error_k$$

$$I_k = I_Gain * ErrorSum_k$$

$$D_k = D_Gain * (Error_k - Error_{k-1})$$

$$Error_k = Target - Feedback$$

$$ErrorSum_k = ErrorSum_{k-1} + Error_k$$

$$P_Gain = G$$

$$I_Gain = G * K_i * T / T_i \text{ (Note: If } T_i \text{ is zero, } I_Gain = 0)$$

$$D_Gain = G * K_d * T_d / T$$

$$T = Loop_Update_Rate * 0.001$$

Each system will have to be tuned for the optimum output response. Response times, overshoots and other variables will have to be decided by the customer using an appropriate PID tuning strategy.

1.6. Diagnostics

There are eight built in CANopen EMCY messages built in. The power supply, the CPU temperature, the out-of-range status of each of the inputs and the status of the gate driver chip are monitored by the firmware.

If any of the variables are out of range or the gate driver error status bits get set, a corresponding CANopen EMY is sent.

EMCY Data	Meaning
0x 00 31 01 00 01 00 00 00	VPS out of range
0x 00 42 01 00 02 00 00 00	CPU temperature out of range
0x 10 F0 01 00 40 00 00 00	Input #1 out of range
0x 10 F0 01 00 41 00 00 00	Input #2 out of range
0x 10 F0 01 00 42 00 00 00	Input #3 out of range
0x 10 F0 01 00 43 00 00 00	Input #4 out of range
0x 02 F0 01 00 60 00 00 00	Gate driver malfunction
0x 10 81 01 00 00 00 00 00	Communications error

Table 17 – EMCY codes

1.7. Control Logic Block

The Control Logic function block implements simple control and enable logic that can be used for creating control signals for the other function blocks.

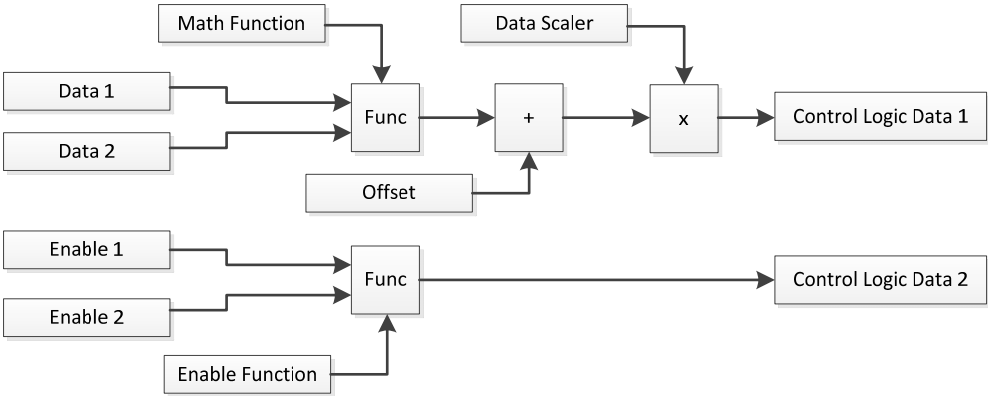

Figure 11 – Control Logic block diagram

The Control Logic function block includes two user selectable sources for Data and two user selectable sources for enable data. The data and enable sources are connected to Math functions, both of which implement equation $A \text{ op } B$, where A and B are function inputs and operator is function selected with setpoint 4150h **Math/Enable function to use**. Allowed configuration options are presented in Table 18.

$$\text{Logic Block Output 1} = ((A \text{ op } B) + \text{Offset}) \times \text{Scaler}$$

$$\text{Logic Block Output 2} = (A \text{ op } B)$$

0	<i>=, True when InA equals InB</i>
1	<i>!=, True when InA not equal InB</i>
2	<i>>, True when InA greater than InB</i>
3	<i>>=, True when InA greater than or equal InB</i>
4	<i><, True when InA less than InB</i>
5	<i><=, True when InA less than or equal InB</i>
6	<i>OR, True when InA or InB is True</i>
7	<i>AND, True when InA and InB are True</i>
8	<i>XOR, True when either InA or InB is True, but not both</i>
9	<i>+, Result = InA plus InB</i>
10	<i>-, Result = InA minus InB</i>
11	<i>x, Result = InA times InB</i>
12	<i>/, Result = InA divided by InB</i>
13	<i>MIN, Result = Smallest of InA and InB</i>
14	<i>MAX, Result = Largest of InA and InB</i>
15	<i>MAX-MIN, Result = Absolute value of (InA – InB)</i>

Table 18 – Math/Enable function to use Options

For logic operations (6, 7, 8) input greater or equal to 1 is treated as TRUE. For logic operations (0 to 8), the result of the function will always be 0 (FALSE) or 1 (TRUE). For the arithmetic functions (9 to 14), the output value will be limited between maximum of 32767 and minimum of -32768.

When dividing, a zero divider will always result in a maximum output value for the associated function.

The 4140h **Data Scaler** object can be used for scaling the Control Logic output value into the preferred range. The other function blocks, such as the target RPM setting for the motor, expect data values in range 0...1.

There is also special data available in the Control Logic Data, that can be used for example transmitting the controller status over CAN using CAN Transmit Messages. In Figure 12, the **RotorTargetRPM** is the internal target RPM after ramp function, speed control loop and current control loop. **MotorStalled** is a flag (0/1) indicating if the controller has detected motor stalled condition. **DFuncDesired** is the PWM drive value applied to the output driver FETs (range 0x0 ... 0x7FFF). **DRV8301_Flags** are the status flags of the motor control chip, for further details please see section 0. The calculated motor power is available in Control Logic Data #7.

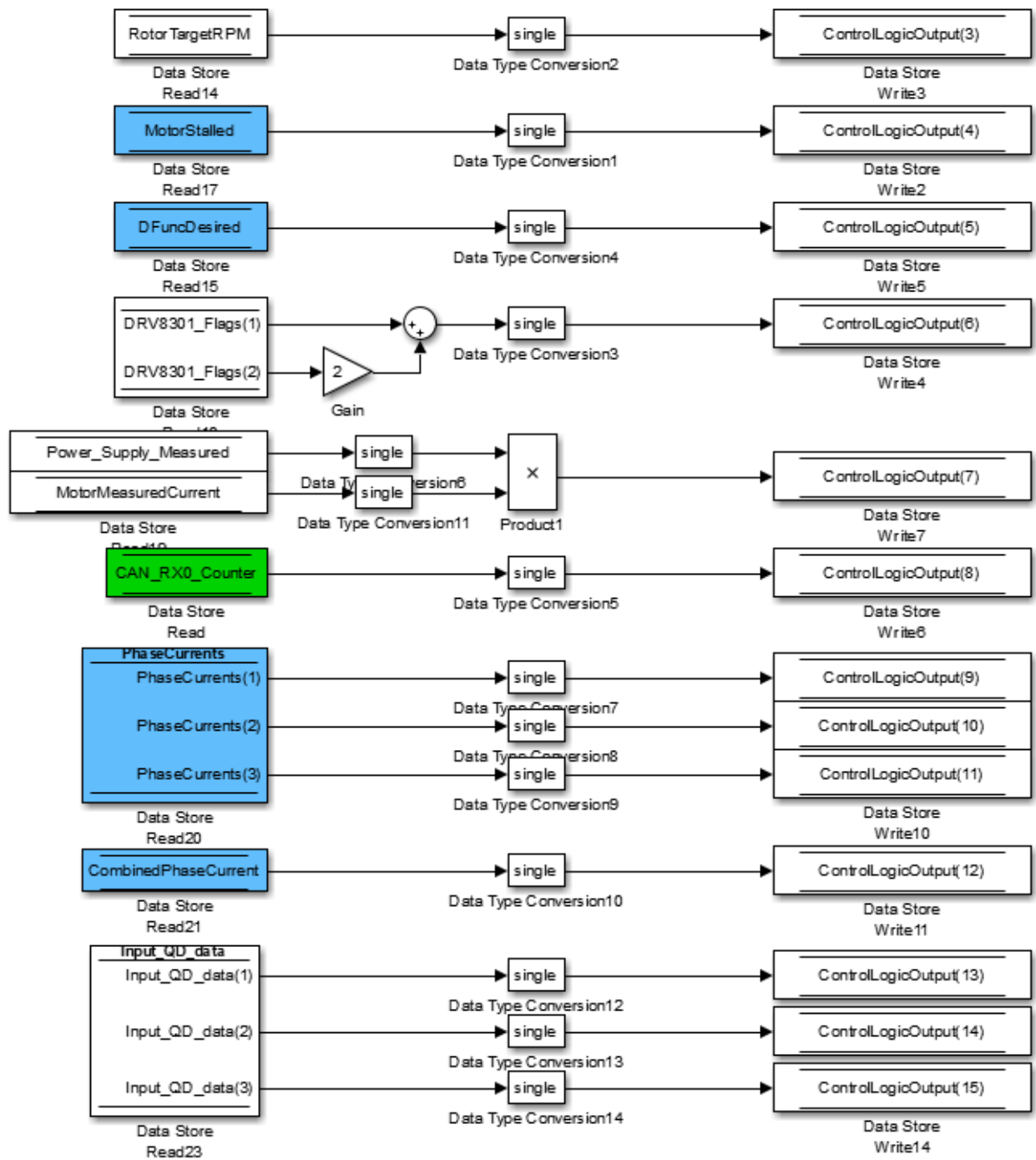

Figure 12 – Special data available in Control Logic Data

1.8. Miscellaneous Function Block

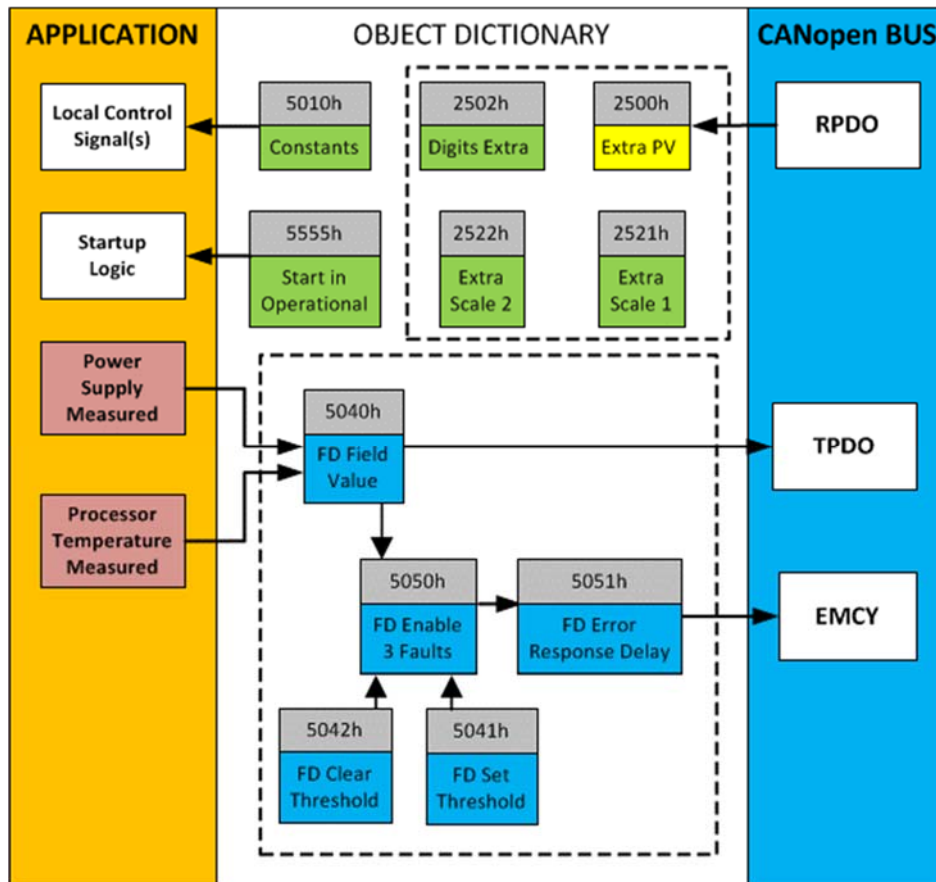

Figure 13 – Miscellaneous Objects

Extra RPDO Messages

Objects 2500h **Extra Control Received PV**, 2502h **EC Decimal Digits PV**, 2502h **EC Scaling 1 PV** and **EC Scaling 2 PV** allow for additional data received on a CANopen® RPDO to be mapped independently to various function blocks as a control source. The scaling objects are provided to define the limits of the data when it is used by another function block, as shown in Figure 9.

Constant Values

Object 5010h **Constant Field Value** is provided to give the user the option for a fixed value that can be used by other function blocks. Sub-index 1 is fixed as FALSE (0) and sub-index 2 is always TRUE (1). There are 13 other sub-indexes provided for user selectable values.

The constants are read as 32-bit real (float) data, so no decimal digit object is provided. When setting up the constant, make sure to do it with the resolution of the object that will be compared with it.

The False/True constants are provided primarily to be used with the logic block. The variable constants are also useful with the logic or math blocks.

Fault Detection Objects

Object 5040h **FD Field Value** is a read only object containing the field values of the over temperature, over and under voltage. Object 5041h **FD Set Threshold** sets the limit values for which the faults occur when reached. When any of these thresholds are reached, the faults will clear when the values have lowered to values set in object 5042h **FD Clear Threshold**.

For the AX100261 controller to begin monitoring fault detections, object 5050h **Error Check Detection** determines which Fault Detection is enabled through 1 byte data as bits. Once a fault is detected, object 5051h **Error Response Delay** will determine how long (in 100ms steps) the fault needs to be present to flag and error.

Startup

The last object 5555h **Start in Operational** is provided as a ‘cheat’ when the unit is not intended to work with a CANopen network (i.e. a stand-alone control) or is working on a network comprised solely as slaves so the OPERATION command will never be received from a master. By default, this object is disabled (FALSE).

When using the AX100261 as a stand-alone controller where 5555h is set to TRUE, it is recommended to disable all TPDOs (set the Event Timer to zero) so that it does not run with a continuous CAN error when not connected to a bus.

1.9. Available Control Sources

Many of the Function Blocks have selectable input signals, which are determined with “[Name] Source” and “[Name] Number” setpoints. Together, these setpoints uniquely select how the I/O of the various function blocks are linked together. “[Name] Source” setpoint determines the type of the source and “[Name] Number” selects the actual source if there is more than one of the same type. Available “[Name] Source” options and associated “[Name] Number” ranges are listed in Table 19. All sources are available for all blocks. Though input Sources are freely selectable, it must be remembered that not all options would make sense in all cases, and it is up to the user to program the controller in a logical and functional manner.

Sources	Number Range	Notes
<i>0: Control Not Used</i>	N/A	When this is selected, it disables all other setpoints associated with the signal in question.
<i>1: Received CAN Message</i>	1 to 4	User must enable the function block, as it is disabled by default.
<i>2: Universal Input Measured</i>	1 to 4	
<i>3: Control Logic Data</i>	1 to 8	User must enable the function block, as it is disabled by default.
<i>4: PID Function Block</i>	1	User must enable the function block, as it is disabled by default.
<i>5: Control Constant Data</i>	1 to 8	1 = FALSE, 2 = TRUE, 3 to 15 = User Selectable
<i>6: Motor RPM Value</i>	1 to 255	Measured RPM reading. The Parameter sets the threshold in N*100RPM to compare with.
<i>7: Motor Current Feedback</i>	1 to 255	Measured motor current in Amps. The Parameter sets the threshold in N*50mA to compare with.
<i>8: Power Supply Measured</i>	1 to 255	Measured power supply value in Volts. The Parameter sets the threshold in Volts to compare with.
<i>9: Processor Temperature Measured</i>	1 to 255	Measured processor temperature in °C. The Parameter sets the threshold in Celcius to compare with.
<i>10: CAN Reception Timeout</i>	N/A	

Table 19 – Available Control Sources and Numbers

Control Constant Data has no unit nor minimum and maximum assigned to it, therefore user has to assign appropriate constant values according to intended use.

2. INSTALLATION INSTRUCTIONS

2.1. Dimensions and Pinout

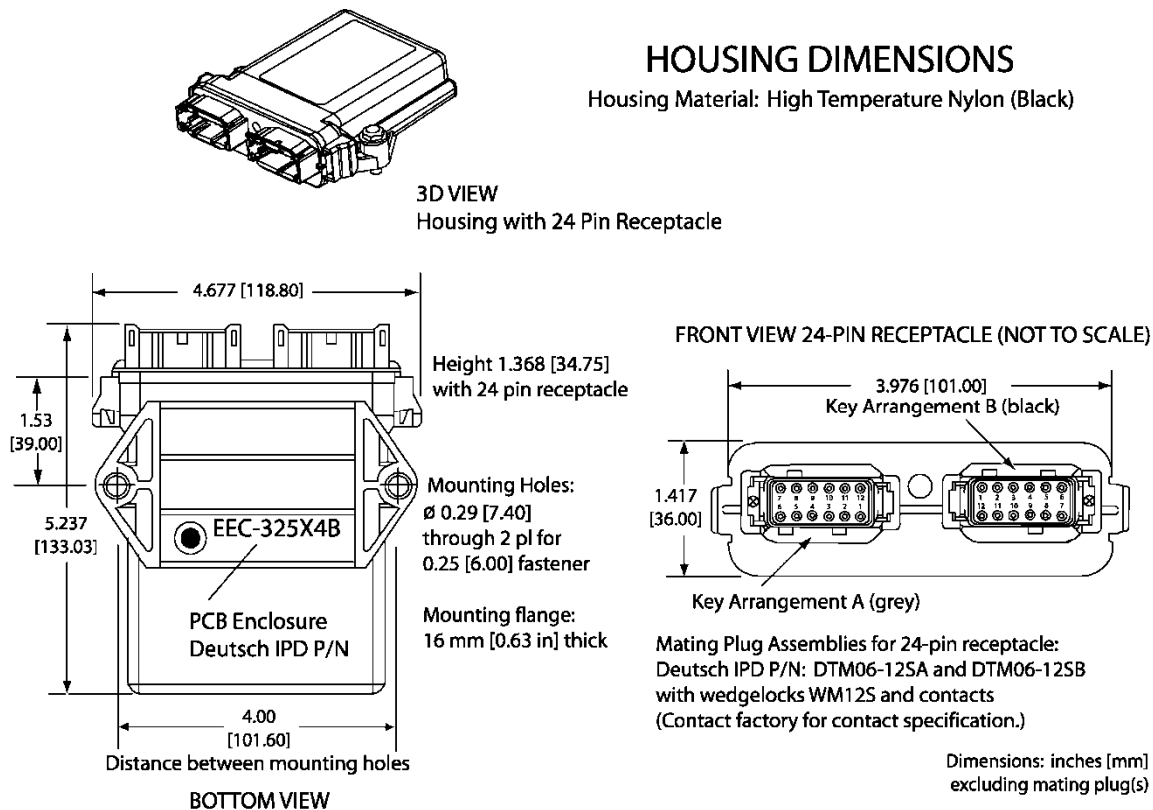

Figure 14 – AX100261 Dimensional Drawing

Grey Connector PIN #	Function	Black Connector PIN #	Function
12	CAN_H	12	Analog GND
11	Hall C	11	Universal Input 4
10	Hall A	10	+5V Reference
9	Motor PWM (Phase A)	9	Analog GND
8	Motor PWM (Phase B)	8	Universal Input 3
7	Battery -	7	+5V Reference
6	Battery +	6	Analog GND
5	Motor PWM (Phase C)	5	Universal Input 2
4	Hall 5V Reference	4	+5V Reference
3	Hall B	3	Analog GND
2	Hall GND	2	Universal Input 1
1	CAN_L	1	+5V Reference

Table 20 – AX100261 Connector Pinout

3. CANOPEN INTERFACE AND OBJECT DICTIONARY

The CANopen® object dictionary of the AX100261 Controller is based on CiA device profile DS-402 V4.1.0 (drives and motion control device profile). The object dictionary includes Communication Objects beyond the minimum requirements in the profile, as well as several manufacturer-specific objects for extended functionality.

3.1. Node ID and Baud rate

By default, the AX100261 controller ships factory programmed with a

Node ID = 127 (0x7F)

and with

Baud rate = 125 kbps.

3.1.1. LSS Protocol to Update

The only means by which the Node-ID and Baud rate can be changed is to use Layer Settling Services (LSS) and protocols as defined by CANopen® standard DS-305.

Follow the steps below to configure either variable using LSS protocol. If required, please refer to the standard for more detailed information about how to use the protocol

3.1.1.1. Setting Node-ID

- Set the module state to LSS-configuration by **sending** the following message:

<i>Item</i>	<i>Value</i>
COB-ID	0x7E5
Length	2
Data 0	0x04 (cs=4 for switch state global)
Data 1	0x01 (switches to configuration state)

- Set the Node-ID by **sending** the following message:

<i>Item</i>	<i>Value</i>
COB-ID	0x7E5
Length	2
Data 0	0x11 (cs=17 for configure node-id)
Data 1	Node-ID (set new Node-ID as a hexadecimal number)

- The module will send the following response (any other response is a failure).

<i>Item</i>	<i>Value</i>
COB-ID	0x7E4

Length	3
Data 0	0x11 (cs=17 for configure node-id)
Data 1	0x00
Data 2	0x00

- Save the configuration by **sending** the following message:

<i>Item</i>	<i>Value</i>
COB-ID	0x7E5
Length	1
Data 0	0x17 (cs=23 for store configuration)

- The module will send the following response (any other response is a failure)

<i>Item</i>	<i>Value</i>
COB-ID	0x7E4
Length	3
Data 0	0x17 (cs=23 for store configuration)
Data 1	0x00
Data 2	0x00

- Set the module state to LSS-operation by **sending** the following message: (Note, the module will reset itself back to the pre-operational state)

<i>Item</i>	<i>Value</i>
COB-ID	0x7E5
Length	2
Data 0	0x04 (cs=4 for switch state global)
Data 1	0x00 (switches to waiting state)

3.1.1.2. Setting Baud rate

- Set the module state to LSS-configuration by sending the following message:

<i>Item</i>	<i>Value</i>
COB-ID	0x7E5
Length	2
Data 0	0x04 (cs=4 for switch state global)
Data 1	0x01 (switches to configuration state)

- Set the baud rate by sending the following message:

<i>Item</i>	<i>Value</i>
COB-ID	0x7E5
Length	3
Data 0	0x13 (cs=19 for configure bit timing parameters)
Data 1	0x00 (switches to waiting state)
Data 2	Index (select baudrate index per Table 32)

Index	Bit Rate
0	1 Mbit/s
1	800 kbit/s
2	500 kbit/s
3	250 kbit/s
4	125 kbit/s (default)
5	reserved (100 kbit/s)
6	50 kbit/s
7	20 kbit/s
8	10 kbit/s

Table 21 – LSS Baud rate Indices

- The module will send the following response (any other response is a failure):

Item	Value
COB-ID	0x7E4
Length	3
Data 0	0x13 (cs=19 for configure bit timing parameters)
Data 1	0x00
Data 2	0x00

- Activate bit timing parameters by sending the following message:

Item	Value
COB-ID	0x7E5
Length	3
Data 0	0x15 (cs=19 for activate bit timing parameters)
Data 1	<delay_lsb>
Data 2	<delay_msb>

The delay individually defines the duration of the two periods of time to wait until the bit timing parameters switch is done (first period) and before transmitting any CAN message with the new bit timing parameters after performing the switch (second period). The time unit of switch delay is 1 ms.

- Save the configuration by sending the following message (on the NEW baud rate):

Item	Value
COB-ID	0x7E5
Length	1
Data 0	0x17 (cs=23 for store configuration)

- The module will send the following response (any other response is a failure):

Item	Value
COB-ID	0x7E4
Length	3
Data 0	0x17 (cs=23 for store configuration)
Data 1	0x00

Data 2	0x00
--------	------

- Set the module state to LSS-operation by sending the following message: (Note, the module will reset itself back to the pre-operational state)

Item	Value
COB-ID	0x7E5
Length	2
Data 0	0x04 (cs=4 for switch state global)
Data 1	0x00 (switches to waiting state)

The following screen capture (left) shows the CAN data was sent (7E5h) and received (7E4h) by the tool when the baud rate was changed to 250 kbps using the LSS protocol. The other image (right) shows what was printed on an example debug RS-232 menu while the operation took place.

Between CAN Frame 98 and 99, the baud rate on the CAN Scope tool was changed from 125 to 250 kbps.

The left screenshot shows the CAN Scope tool interface. The 'Add/Delete ID Area' section has '0x000 <> 0x7FF' entered. The 'Baud rate' is set to 250. The frame capture table is as follows:

Frame	Absolute Time	RelTime	Id	Atr	L	d1	d2	d3	d4
95	11:42:45.248	6110	07E5		2	04	01		
96	11:42:54.468	9219	07E5		3	13	00	03	
97	11:42:54.468	0	07E4		3	13	00	00	
98	11:42:58.687	4218	07E5		3	15	88	13	
99	11:43:16.579	17891	07E5		1	17			
100	11:43:16.907	328	07E4		3	17	00	00	
101	11:43:23.017	6109	07E5		2	04	00		
102	11:43:23.017	0	0750		1	00			

The right screenshot shows the debug RS-232 menu with the following text:

```

===== Main Menu =====
Choose one of the following:
U: View Object Dictionary
D: Default Object Dictionary
T: Toggle RS-232 Stream On/Off
S: Show/Stop Diagnostics
L: Load New Software
M: Main Menu (this)

->Node Id = 80
->Baudrate= 125 [kbps]
CO: PRE-OPERATIONAL
Activating new baud = 250 [kbps]
CO: STOP
Restarting CAN in 5000 [ms]
CO: PRE-OPERATIONAL
Storing ID
Storing Factory Parameters

Storing Baud
Storing Factory Parameters

Storing Communication Parameters

->Node Id = 80
->Baudrate= 250 [kbps]
CO: PRE-OPERATIONAL

```

3.2. Communication Objects (DS-301)

Index (hex)	Object	Object Type	Data Type	Access	PDO Mapping
1000	Device Type	VAR	UNSIGNED32	RO	No
1001	Error Register	VAR	UNSIGNED8	RO	No
1002	Manufacturer Status Register	VAR	UNSIGNED32	RO	No
1003	Pre-Defined Error Field	ARRAY	UNSIGNED32	RO	No
1010	Store Parameters	ARRAY	UNSIGNED32	RW	No
1011	Restore Default Parameters	ARRAY	UNSIGNED32	RW	No
1016	Consumer Heartbeat Time	ARRAY	UNSIGNED32	RW	No
1017	Producer Heartbeat Time	VAR	UNSIGNED16	RW	No
1018	Identity Object	RECORD		RO	No
1020	Verify Configuration	ARRAY	UNSIGNED32	RO	No
1029	Error Behavior	ARRAY	UNSIGNED8	RW	No
1400	RPDO1 Communication Parameter	RECORD		RW	No
1401	RPDO2 Communication Parameter	RECORD		RW	No
1402	RPDO3 Communication Parameter	RECORD		RW	No
1403	RPDO4 Communication Parameter	RECORD		RW	No
1600	RPDO1 Mapping Parameter	RECORD		RO	No
1601	RPDO2 Mapping Parameter	RECORD		RO	No
1602	RPDO3 Mapping Parameter	RECORD		RO	No
1603	RPDO4 Mapping Parameter	RECORD		RO	No
1800	TPDO1 Communication Parameter	RECORD		RW	No
1801	TPDO2 Communication Parameter	RECORD		RW	No
1802	TPDO3 Communication Parameter	RECORD		RW	No
1803	TPDO4 Communication Parameter	RECORD		RW	No
1A00	TPDO1 Mapping Parameter	RECORD		RW	No
1A01	TPDO2 Mapping Parameter	RECORD		RW	No
1A02	TPDO3 Mapping Parameter	RECORD		RW	No
1A03	TPDO4 Mapping Parameter	RECORD		RW	No

3.2.1. 1000h Device Type

Index	Subindex	Data Type	Access	PDO Mapping	Value Range	Default Value	Description
1000	0	UINT32	RO	No	0x192	0x192	DS-402

3.2.2. 1001h Error Register

Index	Subindex	Data Type	Access	PDO Mapping	Value Range	Default Value	Description
1001	0	UINT8	RO	No	0, 1	0	Error register

3.2.3. 1002h Manufacturer Status Object

Index	Subindex	Data Type	Access	PDO Mapping	Value Range	Default Value	Description
1002	0	UINT32	RO	No	UINT32	0	Manufacturer debug information

3.2.4. 1003h Pre-Defined Error Field

Index	Subindex	Data Type	Access	PDO Mapping	Value Range	Default Value	Description	
1003	0	UINT8	RW	No	15	15	Number of subindexes / reset error codes	
	1	UINT32	RO		UINT32	0		EMCY error code #1
	2							EMCY error code #2
	3							EMCY error code #3
	4							EMCY error code #4
	5							EMCY error code #5
	6							EMCY error code #6
	7							EMCY error code #7
	8							EMCY error code #8
	9							EMCY error code #9
	10							EMCY error code #10
	11							EMCY error code #11
	12							EMCY error code #12
	13							EMCY error code #13
	14							EMCY error code #14
15	EMCY error code #15							

3.2.5. 1010h Store Parameters

Index	Subindex	Data Type	Access	PDO Mapping	Value Range	Default Value	Description	
1010	0	UINT8	RO	No	4	4	Number of subindexes	
	1	UINT32	RW			save	1	Write 0x65766173 ('e', 'v', 'a', 's') for storing ALL parameters
	2							Write 0x65766173 ('e', 'v', 'a', 's') for storing Communication parameters
	3							Write 0x65766173 ('e', 'v', 'a', 's') for storing Application parameters
4	Write 0x65766173 ('e', 'v', 'a', 's') for storing Manufacturer parameters							

3.2.6. 1011h Restore Parameters

Index	Subindex	Data Type	Access	PDO Mapping	Value Range	Default Value	Description
1011	0	UINT8	RO	No	4	4	Number of subindexes
	1	UINT32	RW		load	1	Write 0x4616F6C ('d', 'a', 'o', 'l') for restoring ALL parameters
	2				Write 0x4616F6C ('d', 'a', 'o', 'l') for restoring Communication parameters		
	3				Write 0x4616F6C ('d', 'a', 'o', 'l') for restoring Application parameters		
	4				Write 0x4616F6C ('d', 'a', 'o', 'l') for restoring Manufacturer parameters		

3.2.7. 1016h Consumer Heartbeat Time

Index	Subindex	Data Type	Access	PDO Mapping	Value Range	Default Value	Description
1016	0	UINT8	RO	No	4	4	Number of subindexes
	1	UINT32	RW		UINT32	0	Consumer heartbeat time bits 31-24: reserved bits 23-16: Node ID bits 15-0: heartbeat time in milliseconds
	2						
	3						
	4						

3.2.8. 1017h Producer Heartbeat Time

Index	Subindex	Data Type	Access	PDO Mapping	Value Range	Default Value	Description
1017	0	UINT16	RW	No	10-65000	0	Producer heartbeat time in milliseconds

3.2.9. 1018h Identity Object

Index	Subindex	Data Type	Access	PDO Mapping	Value Range	Default Value	Description
1018	0	UINT8	RO	No	4	4	Number of subindexes
	1	UINT32			UINT32	0x55	Vendor ID (Axiomatic Technologies)
	2					0xAA100261	Product Code
	3						Revision Number
	4						Serial Number

3.2.10. 1020h Verify Configuration

Index	Subindex	Data Type	Access	PDO Mapping	Value Range	Default Value	Description
1020	0	UINT8	RO	No	4	4	Number of subindexes
	1	UINT32			UINT32		Configuration date: DD-MM-YYYY
	2						Configuration time: HH-MM

3.2.11. 1029h Error Behavior

Index	Subindex	Data Type	Access	PDO Mapping	Value Range	Default Value	Description	
1029	0	UINT8	RO	No	6	4	Number of subindexes	
	1		RW		0-2		1 (no change)	State transition on Comm. fault
	2							State transition on DI fault
	3							State transition on AI fault
	4							State transition on DO fault
	5							State transition on AO fault
	6							State transition on other faults

3.2.12. 1400h RPDO 1 Communication Parameters

Index	Subindex	Data Type	Access	PDO Mapping	Value Range	Default Value	Description
1400	0	UINT8	RO	No	4	4	Number of subindexes
	1	UINT32	RW		UINT32	0x4000027F	COB-ID
	2	UINT8			UINT8	0xFF	Transmission type
	3	UINT16			UINT16	0	Inhibit time
	4	UINT8			UINT8	0	Compatibility entry
	5	UINT16			UINT16	0	Event timer

3.2.13. 1401h RPDO 2 Communication Parameters

Index	Subindex	Data Type	Access	PDO Mapping	Value Range	Default Value	Description
1401	0	UINT8	RO	No	4	4	Number of subindexes
	1	UINT32	RW		UINT32	0x4000037F	COB-ID
	2	UINT8			UINT8	0xFF	Transmission type
	3	UINT16			UINT16	0	Inhibit time
	4	UINT8			UINT8	0	Compatibility entry
	5	UINT16			UINT16	0	Event timer

3.2.14. 1402h RPDO 3 Communication Parameters

Index	Subindex	Data Type	Access	PDO Mapping	Value Range	Default Value	Description
1402	0	UINT8	RO	No	4	4	Number of subindexes
	1	UINT32	RW		UINT32	0xC000047F	COB-ID
	2	UINT8			UINT8	0xFF	Transmission type
	3	UINT16			UINT16	0	Inhibit time
	4	UINT8			UINT8	0	Compatibility entry
	5	UINT16			UINT16	0	Event timer

3.2.15. 1403h RPDO 4 Communication Parameters

Index	Subindex	Data Type	Access	PDO Mapping	Value Range	Default Value	Description
1403	0	UINT8	RO	No	4	4	Number of subindexes
	1	UINT32	RW		UINT32	0xC000057F	COB-ID
	2	UINT8			UINT8	0xFF	Transmission type
	3	UINT16			UINT16	0	Inhibit time
	4	UINT8			UINT8	0	Compatibility entry
	5	UINT16			UINT16	0	Event timer

3.2.16. 1600h RPDO 1 Mapping Parameters

Index	Subindex	Data Type	Access	PDO Mapping	Value Range	Default Value	Description
1600	0	UINT8	RW	No	0-4	2	Number of subindexes
	1	UINT32			UINT32	0x607E0008	Polarity
	2				0x60FF0020	Target velocity	
	3				0	Not used by default	
	4				0	Not used by default	

3.2.17. 1601h RPDO 2 Mapping Parameters

Index	Subindex	Data Type	Access	PDO Mapping	Value Range	Default Value	Description
1601	0	UINT8	RW	No	0-4	4	Number of subindexes
	1	UINT32			UINT32	0x25000110	EC Extra Received PV Value 1
	2				0x25000210	EC Extra Received PV Value 2	
	3				0x25000310	EC Extra Received PV Value 3	
	4				0x25000410	EC Extra Received PV Value 4	

3.2.18. 1602h RPDO 3 Mapping Parameters

Index	Subindex	Data Type	Access	PDO Mapping	Value Range	Default Value	Description
1602	0	UINT8	RW	No	0-4	0	Number of subindexes
	1	UINT32			UINT32	0	Not used by default
	2				0	Not used by default	
	3				0	Not used by default	
	4				0	Not used by default	

3.2.19. 1603h RPDO 4 Mapping Parameters

Index	Subindex	Data Type	Access	PDO Mapping	Value Range	Default Value	Description
1603	0	UINT8	RW	No	0-4	0	Number of subindexes
	1	UINT32			UINT32	0	Not used by default
	2				0	Not used by default	
	3				0	Not used by default	
	4				0	Not used by default	

3.2.20. 1800h TPDO 1 Communication Parameters

Index	Subindex	Data Type	Access	PDO Mapping	Value Range	Default Value	Description
1800	0	UINT8	RO	No	4	4	Number of subindexes
	1	UINT32	RW		UINT32	0x400001FF	COB-ID
	2	UINT8			UINT8	0xFE	Transmission type
	3	UINT16			UINT16	0	Inhibit time
	4	UINT8			UINT8	0	Compatibility entry
	5	UINT16			UINT16	0x64	Event timer

3.2.21. 1801h TPDO 2 Communication Parameters

Index	Subindex	Data Type	Access	PDO Mapping	Value Range	Default Value	Description
1801	0	UINT8	RO	No	4	4	Number of subindexes
	1	UINT32	RW		UINT32	0x400002FF	COB-ID
	2	UINT8			UINT8	0xFE	Transmission type
	3	UINT16			UINT16	0	Inhibit time
	4	UINT8			UINT8	0	Compatibility entry
5	UINT16	UINT16		0x64	Event timer		

3.2.22. 1802h TPDO 3 Communication Parameters

Index	Subindex	Data Type	Access	PDO Mapping	Value Range	Default Value	Description
1802	0	UINT8	RO	No	4	4	Number of subindexes
	1	UINT32	RW		UINT32	0x400003FF	COB-ID
	2	UINT8			UINT8	0xFE	Transmission type
	3	UINT16			UINT16	0	Inhibit time
	4	UINT8			UINT8	0	Compatibility entry
5	UINT16	UINT16		0	Event timer		

3.2.23. 1803h TPDO 4 Communication Parameters

Index	Subindex	Data Type	Access	PDO Mapping	Value Range	Default Value	Description
1803	0	UINT8	RO	No	4	4	Number of subindexes
	1	UINT32	RW		UINT32	0xC00004FF	COB-ID
	2	UINT8			UINT8	0xFE	Transmission type
	3	UINT16			UINT16	0	Inhibit time
	4	UINT8			UINT8	0	Compatibility entry
5	UINT16	UINT16		0	Event timer		

3.2.24. 1A00h TPDO 1 Mapping Parameters

Index	Subindex	Data Type	Access	PDO Mapping	Value Range	Default Value	Description
1A00	0	UINT8	RW	No	0-4	4	Number of subindexes
	1	UINT32			UINT32	0x71000110	Universal Input #1 FV
	2				0x71000210	Universal Input #2 FV	
	3				0x71000310	Universal Input #3 FV	
4	0x71000410		Universal Input #4 FV				

3.2.25. 1A01h TPDO 2 Mapping Parameters

Index	Subindex	Data Type	Access	PDO Mapping	Value Range	Default Value	Description
1A01	0	UINT8	RW	No	0-4	2	Number of subindexes
	1	UINT32			UINT32	0x60410010	PDS FSA Status Word
	2				0x606C0020	Velocity Actual Value	
	3				0	Not used by default	
4	0		Not used by default				

3.2.26. 1A02h TPDO 3 Mapping Parameters

Index	Subindex	Data Type	Access	PDO Mapping	Value Range	Default Value	Description
1A02	0	UINT8	RW	No	0-4	2	Number of subindexes
	1	UINT32			UINT32	0x50200020	Processor Temperature Field Value
	2				0x50300020	Power Supply Field Value	
	3				0	Not used by default	
	4				0	Not used by default	

3.2.27. 1A03h TPDO 4 Mapping Parameters

Index	Subindex	Data Type	Access	PDO Mapping	Value Range	Default Value	Description
1A03	0	UINT8	RW	No	0-4	0	Number of subindexes
	1	UINT32			UINT32	0	Not used by default
	2				0	Not used by default	
	3				0	Not used by default	
	4				0	Not used by default	

3.3. Application Objects (DS-402 Motor Control and DS-404 Inputs & PID)

Index (hex)	Object	Object Type	Data Type	Access	PDO Mapping
6000	DI Read State 8 Input Lines	VAR	UNSIGNED8	RO	Yes
6002	DI Polarity 8 Input Lines	VAR	UNSIGNED8	RW	No
7100	AI Input Field Value	ARRAY	INTEGER16	RO	Yes
6110	AI Sensor Type	ARRAY	UNSIGNED16	RW	No
6112	AI Operating Mode	ARRAY	UNSIGNED8	RW	No
7120	AI Input Scaling 1 FV	ARRAY	INTEGER16	RW	No
7121	AI Input Scaling 1 PV	ARRAY	INTEGER16	RW	No
7122	AI Input Scaling 2 FV	ARRAY	INTEGER16	RW	No
7123	AI Input Scaling 2 PV	ARRAY	INTEGER16	RW	No
7130	AI Input Process Value	ARRAY	INTEGER16	RO	Yes
6132	AI Decimal Digits PV	ARRAY	UNSIGNED8	RW	No
7148	AI Input Span Start	ARRAY	INTEGER16	RW	No
7149	AI Input Span End	ARRAY	INTEGER16	RW	No
61A0	AI Filter Type	ARRAY	UNSIGNED8	RW	No
61A1	AI Filter Constant	ARRAY	UNSIGNED16	RW	No
6040	PDS FSA Control Word	VAR	UNSIGNED16	RW	Yes
6041	PDS FSA Status Word	VAR	UNSIGNED16	RO	Yes
6060	PDS FSA Modes of Operation	VAR	INTEGER8	RW	No
6061	PDS FSA Modes of Operation Display	VAR	INTEGER8	RO	No
6502	PDS FSA Supported Drive Modes	VAR	UNSIGNED32	RO	No
60FF	Target Velocity	VAR	INTEGER32	RW	Yes
6080	Max Motor Speed	VAR	UNSIGNED32	RW	No
6085	Quick Stop Deceleration	VAR	UNSIGNED32	RW	No
607E	Polarity	VAR	UNSIGNED8	RW	Yes
60C2	Interpolation Time Period	ARRAY	UNSIGNED8	RW	No
606C	Velocity Actual Value	VAR	INTEGER32	RW	Yes
6071	Target Torque	VAR	INTEGER16	RW	Yes
6072	Max Torque	VAR	UNSIGNED16	RW	No
6076	Rated Torque	VAR	UNSIGNED32	RW	No
6077	Torque Actual Value	VAR	UNSIGNED32	RW	Yes
7450	PID Proportional Band	ARRAY	INTEGER16	RW	No
7452	PID Integral Action Time	ARRAY	INTEGER16	RW	No
7454	PID Derivative Action Time	ARRAY	INTEGER16	RW	No
7456	PID Cycle Time	ARRAY	INTEGER16	RW	No
6458	PID Physical Unit Timing	ARRAY	UNSIGNED32	RO	No
6459	PID Decimal Digits Timing	ARRAY	INTEGER8	RW	No

3.3.1. 6000h DI Read State 8 Input Lines

Index	Subindex	Data Type	Access	PDO Mapping	Value Range	Default Value	Description
6000	0	UINT8	RO	Yes	0x0 ... 0x3F	0	Digital Input state bitmap, one bit per input. Inputs 5 & 6 are gate driver's active low fault lines.

3.3.2. 6002h DI Polarity 8 Input Lines

Index	Subindex	Data Type	Access	PDO Mapping	Value Range	Default Value	Description
6002	0	UINT8	RW	No	0x0 ... 0x3F	0	Digital Input state polarity bitmap, one bit per input. Inputs 5 & 6 are gate driver's active low fault lines.

3.3.3. 7100h AI Input Field Value

Index	Subindex	Data Type	Access	PDO Mapping	Value Range	Default Value	Description	
7100	0	UINT8	RO	No	6	6	Number of subindexes	
	1	INT16	RW			INT16	0	Input #1 field value
	2							Input #2 field value
	3							Input #3 field value
	4							Input #4 field value
	5							Gate driver FAULT pin status (active low)
	6							Gate driver OCTW pin status (active low)

3.3.4. 6110h AI Sensor Type

Index	Subindex	Data Type	Access	PDO Mapping	Value Range	Default Value	Description	
6110	0	UINT8	RO	No	4	4	Number of subindexes	
	1	UINT16	RW			40,50, 60,100, 10000, 10002	40	Input #1 sensor type
	2							Input #2 sensor type
	3							Input #3 sensor type
	4							Input #4 sensor type

3.3.5. 6112h AI Operating Mode

Index	Subindex	Data Type	Access	PDO Mapping	Value Range	Default Value	Description	
6112	0	UINT8	RO	No	4	4	Number of subindexes	
	1		RW			0-2, sensor type dependent.	1	Input #1 operating mode
	2							Input #2 operating mode
	3							Input #3 operating mode
	4							Input #4 operating mode

3.3.6. 7120h AI Input Scaling 1 FV

Index	Subindex	Data Type	Access	PDO Mapping	Value Range	Default Value	Description
7120	0	UINT8	RO	No	6	6	Number of subindexes
	1	INT16	RW		INT16	0	Input #1 field value scaler 1
	2						Input #2 field value scaler 1
	3						Input #3 field value scaler 1
	4						Input #4 field value scaler 1
	5						Gate driver FAULT pin status scaler 1
	6						Gate driver OCTW pin status scaler 1

3.3.7. 7121h AI Input Scaling 2 FV

Index	Subindex	Data Type	Access	PDO Mapping	Value Range	Default Value	Description
7121	0	UINT8	RO	No	6	6	Number of subindexes
	1	INT16	RW		INT16	0	Input #1 field value scaler 2
	2						Input #2 field value scaler 2
	3						Input #3 field value scaler 2
	4						Input #4 field value scaler 2
	5						Gate driver FAULT pin status scaler 2
	6						Gate driver OCTW pin status scaler 2

3.3.8. 7122h AI Input Scaling 1 PV

Index	Subindex	Data Type	Access	PDO Mapping	Value Range	Default Value	Description
7122	0	UINT8	RO	No	6	6	Number of subindexes
	1	INT16	RW		INT16	0	Input #1 process value scaler 1
	2						Input #2 process value scaler 1
	3						Input #3 process value scaler 1
	4						Input #4 process value scaler 1
	5						Gate driver FAULT pin status scaler 1
	6						Gate driver OCTW pin status scaler 1

3.3.9. 7123h AI Input Scaling 2 PV

Index	Subindex	Data Type	Access	PDO Mapping	Value Range	Default Value	Description
7123	0	UINT8	RO	No	6	6	Number of subindexes
	1	INT16	RW		INT16	0	Input #1 process value scaler 2
	2						Input #2 process value scaler 2
	3						Input #3 process value scaler 2
	4						Input #4 process value scaler 2
	5						Gate driver FAULT pin status scaler 2
	6						Gate driver OCTW pin status scaler 2

3.3.10. 7130h AI Input Process Value

Index	Subindex	Data Type	Access	PDO Mapping	Value Range	Default Value	Description
7130	0	UINT8	RO	No	6	6	Number of subindexes
	1	INT16	RW	Yes	INT16	0	Input #1 process value
	2						Input #2 process value
	3						Input #3 process value
	4						Input #4 process value
	5						Gate driver FAULT pin status (active low)
	6						Gate driver OCTW pin status (active low)

3.3.11. 6132h AI Decimal Digits PV

Index	Subindex	Data Type	Access	PDO Mapping	Value Range	Default Value	Description
6132	0	UINT8	RO	No	6	6	Number of subindexes
	1		RW		0-3	3	Input #1 PV decimal digits
	2						Input #2 PV decimal digits
	3						Input #3 PV decimal digits
	4						Input #4 PV decimal digits
	5						Gate driver FAULT pin status PV decimal digits
	6						Gate driver OCTW pin status PV decimal digits

3.3.12. 7148h AI Input Span Start

Index	Subindex	Data Type	Access	PDO Mapping	Value Range	Default Value	Description
7148	0	UINT8	RO	No	4	4	Number of subindexes
	1	INT16	RW		Input type dependent	200	Input #1 span start
	2						Input #2 span start
	3						Input #3 span start
	4						Input #4 span start

3.3.13. 7149h AI Input Span End

Index	Subindex	Data Type	Access	PDO Mapping	Value Range	Default Value	Description
7149	0	UINT8	RO	No	4	4	Number of subindexes
	1	INT16	RW		Input type dependent	4800	Input #1 span end
	2						Input #2 span end
	3						Input #3 span end
	4						Input #4 span end

3.3.14. 61A0h AI Filter Type

Index	Subindex	Data Type	Access	PDO Mapping	Value Range	Default Value	Description
61A0	0	UINT8	RO	No	4	4	Number of subindexes
	1		RW		0-2	0	Input #1 software filter type
	2		Input #2 software filter type				
	3		Input #3 software filter type				
	4		Input #4 software filter type				

3.3.15. 61A1h AI Filter Constant

Index	Subindex	Data Type	Access	PDO Mapping	Value Range	Default Value	Description	
61A1	0	UINT8	RO	No	4	4	Number of subindexes	
	1	UINT16	RW			1-1000	1	Input #1 software filter constant
	2							Input #2 software filter constant
	3							Input #3 software filter constant
	4							Input #4 software filter constant

3.3.16. 6040h PDS FSA Control Word

Index	Subindex	Data Type	Access	PDO Mapping	Value Range	Default Value	Description
6040	0	UINT16	RW	Yes	0x0 ... 0xFFFF	0	PDS FSA Control Word

3.3.17. 6041h PDS FSA Status Word

Index	Subindex	Data Type	Access	PDO Mapping	Value Range	Default Value	Description
6041	0	UINT16	RO	Yes	0x0 ... 0xFFFF	0	PDS FSA Status Word

3.3.18. 6060h PDS FSA Modes of Operation

Index	Subindex	Data Type	Access	PDO Mapping	Value Range	Default Value	Description
6060	0	INT8	RW	No	-1, 9, 10	9	PDS FSA Modes of Operation -1 = No speed control, no current control 9 = Speed Control 10 = Speed & Current control

3.3.19. 6061h PDS FSA Modes of Operation Display

Index	Subindex	Data Type	Access	PDO Mapping	Value Range	Default Value	Description
6061	0	INT8	RO	No	INT8	9	PDS FSA Modes of Operation Display

3.3.20. 6502h PDS FSA Supported Drive Modes

Index	Subindex	Data Type	Access	PDO Mapping	Value Range	Default Value	Description
6502	0	UINT32	RO	No	UINT32	0x300	PDS FSA Supported drive modes

3.3.21. 60FFh Target Velocity

Index	Subindex	Data Type	Access	PDO Mapping	Value Range	Default Value	Description
60FF	0	INT32	RW	Yes	0-20000	4000	Target velocity (rotor speed) in rpm

3.3.22. 6080h Max Motor Speed

Index	Subindex	Data Type	Access	PDO Mapping	Value Range	Default Value	Description
6080	0	UINT32	RW	No	0-20000	4000	Maximum rotor speed in rpm.

3.3.23. 6085h Quick Stop Deceleration

Index	Subindex	Data Type	Access	PDO Mapping	Value Range	Default Value	Description
6085	0	UINT32	RW	No	0,1	0	Quick stop deceleration action: 0 – ramp down 1 – abrupt stop

3.3.24. 607Eh Polarity

Index	Subindex	Data Type	Access	PDO Mapping	Value Range	Default Value	Description
607E	0	UINT8	RW	Yes	0,1	0	Polarity (direction of rotation) 0 – CW 1 – CCW

3.3.25. 60C2h Interpolation Time Period

Index	Subindex	Data Type	Access	PDO Mapping	Value Range	Default Value	Description
607E	0	UINT8	RO	No	2	2	Number of subindexes
	1		RW		UINT8	1	
	2					253	

3.3.26. 606Ch Velocity Actual Value

Index	Subindex	Data Type	Access	PDO Mapping	Value Range	Default Value	Description
606C	0	INT32	RO	Yes	INT32	0	Velocity (rotor speed) in rpm.

3.3.27. 6071h Target Torque

Index	Subindex	Data Type	Access	PDO Mapping	Value Range	Default Value	Description
6071	0	INT16	RW	Yes	0-12000	6000	Target motor torque in milliamps (mA)

3.3.28. 6072h Max Torque

Index	Subindex	Data Type	Access	PDO Mapping	Value Range	Default Value	Description
6072	0	UINT16	RW	No	0-12000	12000	Max motor torque in milliamps (mA). Maximum value outputted by the controller.

3.3.29. 6076h Rated Torque

Index	Subindex	Data Type	Access	PDO Mapping	Value Range	Default Value	Description
6076	0	UINT32	RW	No	0-12000	6000	Rated motor torque in milliamps (mA). Maximum value handled by the motor.

3.3.30. 6077h Actual Torque

Index	Subindex	Data Type	Access	PDO Mapping	Value Range	Default Value	Description
6077	0	UINT32	RO	Yes	UINT32	0	Measured motor current in milliamps (mA)

3.3.31. 7450h PID Proportional Band

Index	Subindex	Data Type	Access	PDO Mapping	Value Range	Default Value	Description
7450	0	INT16	RW	No	0-100	5	Additional PID controller P gain

3.3.32. 7452h PID Integral Action Time

Index	Subindex	Data Type	Access	PDO Mapping	Value Range	Default Value	Description
7452	0	INT16	RW	No	0-1000	5	Additional PID controller integral action time

3.3.33. 7454h PID Derivative Action Time

Index	Subindex	Data Type	Access	PDO Mapping	Value Range	Default Value	Description
7454	0	INT16	RW	No	0-1000	1	Additional PID controller derivative action time

3.3.34. 7456h PID Cycle Time

Index	Subindex	Data Type	Access	PDO Mapping	Value Range	Default Value	Description
7456	0	INT16	RW	No	0-1000	10	Additional PID controller cycle time

3.3.35. 6458h PID Physical Unit Timing

Index	Subindex	Data Type	Access	PDO Mapping	Value Range	Default Value	Description
6458	0	UINT32	RO	No	12288	12288	Additional PID controller physical unit timing

3.3.36. 6459h PID Decimal Digits Timing

Index	Subindex	Data Type	Access	PDO Mapping	Value Range	Default Value	Description
6459	0	UINT8	RW	No	0-4	3	Additional PID controller decimal digits timing

3.4. Manufacturer Objects

Index (hex)	Object	Object Type	Data Type	Access	PDO Mapping
2100	AI Input Range	ARRAY	UNSIGNED8	RW	No
2101	AI Pulses Per Revolution	ARRAY	UNSIGNED8	RW	No
2102	AI Decimal Digits FV	ARRAY	UNSIGNED8	RW	No
2110	AI Error Detect Enable	ARRAY	BOOLEAN	RW	No
2111	AI Error Clear Hysteresis	ARRAY	INTEGER16	RW	No
2112	AI Error Reaction Delay	ARRAY	UNSIGNED16	RW	No
2020	DI Pull Up Down Mode 1 Input Line	ARRAY	UNSIGNED8	RW	No
3340	Motor Control Input Source	VAR	UNSIGNED8	RW	No
3341	Motor Control Input Number	VAR	UNSIGNED8	RW	No
3350	Motor Direction Input Source	VAR	UNSIGNED8	RW	No
3351	Motor Direction Input Number	VAR	UNSIGNED8	RW	No
3360	Motor Enable Input Source	VAR	UNSIGNED8	RW	No
3361	Motor Enable Input Number	VAR	UNSIGNED8	RW	No
3410	Quadrature Decoder Scaler	VAR	FLOAT32	RW	No
3411	Quadrature Decoder Direction	VAR	UNSIGNED8	RW	No
3412	Quadrature Decoder Offset	VAR	INTEGER32	RW	No
3413	Quadrature Decoder Pulses per Rev	VAR	INTEGER32	RW	No
3510	Number of Pole Pairs	VAR	UNSIGNED8	RW	No
3511	Position Detection	VAR	UNSIGNED8	RW	No
3512	Commutation Sequence	VAR	UNSIGNED8	RW	No
3513	Over Current Clear Time	VAR	UNSIGNED16	RW	No
3514	RPM Pickup Style	VAR	UNSIGNED8	RW	No
3515	PWM Frequency	VAR	UNSIGNED16	RW	No
3610	Speed Regulator P Gain	VAR	FLOAT32	RW	No
3611	Speed Regulator I Gain	VAR	FLOAT32	RW	No
3612	Speed Regulator Open Loop Gain	VAR	FLOAT32	RW	No
3613	Current Regulator P Gain	VAR	FLOAT32	RW	No
3614	Current Regulator I Gain	VAR	FLOAT32	RW	No
3710	Ramp Up	VAR	UNSIGNED16	RW	No
3711	Ramp Down	VAR	UNSIGNED16	RW	No
3713	Output PWM Ramp Time	VAR	UNSIGNED32	RW	No
3714	Startup Period Target	VAR	UNSIGNED32	RW	No
3715	Startup Period Setpoint	VAR	UNSIGNED32	RW	No
3716	Initial Maximum PWM Drive	VAR	UNSIGNED32	RW	No
3717	Gate Driver Overcurrent Vds	VAR	UNSIGNED8	RW	No
2450	PID Tolerance	VAR	INTEGER16	RW	No
2451	PID Integral Gain	VAR	INTEGER16	RW	No
2452	PID Derivative Gain	VAR	INTEGER16	RW	No
2453	PID Target Source	VAR	UNSIGNED8	RW	No
2454	PID Target Number	VAR	UNSIGNED8	RW	No
2455	PID Feedback Source	VAR	UNSIGNED8	RW	No
2456	PID Feedback Number	VAR	UNSIGNED8	RW	No
2457	PID Control Response	VAR	UNSIGNED8	RW	No
2460	PID Output Field Value	VAR	INTEGER16	RO	Yes
2500	EC Extra Received Process Value	ARRAY	INTEGER16	RW	Yes
2502	EC Decimal Digits PV	ARRAY	UNSIGNED8	RW	No
2520	EC Scaling 1 PV	ARRAY	INTEGER16	RW	No

2522	EC Scaling 2 PV	ARRAY	INTEGER16	RW	No
4100	Math 1 Input Source	ARRAY	UNSIGNED8	RW	No
4101	Math 1 Input Number	ARRAY	UNSIGNED8	RW	No
4140	Math 1 Gain	VAR	INTEGER8	RW	No
4150	Math 1 Operator	VAR	UNSIGNED8	RW	No
4160	Math 1 Offset Source	ARRAY	UNSIGNED8	RW	No
4161	Math 1 Offset Number	ARRAY	UNSIGNED8	RW	No
4162	Math 1 Offset Polarity	ARRAY	UNSIGNED8	RW	No
4200	Math 2 Input Source	ARRAY	UNSIGNED8	RW	No
4201	Math 2 Input Number	ARRAY	UNSIGNED8	RW	No
4250	Math 2 Operator	VAR	UNSIGNED8	RW	No
5010	Constant Field Value	ARRAY	FLOAT32	RW	No
5020	Power Supply FV	VAR	FLOAT32	RO	Yes
5030	CPU Temperature FV	VAR	FLOAT32	RO	Yes
5040	Fault Detection Field Value	ARRAY	UNSIGNED16	RO	Yes
5041	Fault Detection Set Threshold	ARRAY	UNSIGNED16	RW	No
5042	Fault Detection Clear Threshold	ARRAY	UNSIGNED16	RW	No
5050	Fault Detection Enable Err Check 3 Faults	ARRAY	UNSIGNED8	RW	No
5051	Fault Detection Error Response Delay	ARRAY	UNSIGNED16	RW	No
5060	Control Logic Output	ARRAY	FLOAT32	RO	Yes
5061	Control Logic Output INT32	ARRAY	INTEGER32	RO	Yes
5555	Start in Operational Mode	VAR	BOOLEAN	RW	No
5556	Start in Operational NMT Delay	VAR	UNSIGNED16	RW	No

3.4.1. 2100h AI Input Range

Index	Subindex	Data Type	Access	PDO Mapping	Value Range	Default Value	Description
2100	0	UINT8	RO	No	4	4	Number of subindexes
	1		RW		Input type dependent	0	Input #1 range selection
	2						Input #2 range selection
	3						Input #3 range selection
	4						Input #4 range selection

3.4.2. 2101h AI Number of Pulses per Revolution

Index	Subindex	Data Type	Access	PDO Mapping	Value Range	Default Value	Description
2101	0	UINT8	RO	No	4	4	Number of subindexes
	1	UINT16	RW		0-1000	0	Input #1 PPR. When 0, no rpm conversion done
	2						Input #2 PPR. When 0, no rpm conversion done
	3						Input #3 PPR. When 0, no rpm conversion done
	4						Input #4 PPR. When 0, no rpm conversion done

3.4.3. 2102h AI Decimal Digits FV

Index	Subindex	Data Type	Access	PDO Mapping	Value Range	Default Value	Description
2102	0	UINT8	RO	No	6	6	Number of subindexes
	1		RW		0-4	3	Input #1 decimal digits FV
	2						Input #2 decimal digits FV
	3						Input #3 decimal digits FV
	4						Input #4 decimal digits FV
	5						Gate driver FAULT pin status decimal digits FV
	6						Gate driver OCTW pin status decimal digits FV

3.4.4. 2110h AI Error Detect Enable

Index	Subindex	Data Type	Access	PDO Mapping	Value Range	Default Value	Description
2110	0	UINT8	RO	No	4	4	Number of subindexes
	1		RW		0, 1	0	Input #1 error detect enable
	2						Input #2 error detect enable
	3						Input #3 error detect enable
	4						Input #4 error detect enable

3.4.5. 2111h AI Error Clear Hysteresis

Index	Subindex	Data Type	Access	PDO Mapping	Value Range	Default Value	Description
2111	0	UINT8	RO	No	4	4	Number of subindexes
	1	INT16	RW		0-32767	100	Input #1 error clear hysteresis
	2						Input #2 error clear hysteresis
	3						Input #3 error clear hysteresis
	4						Input #4 error clear hysteresis

3.4.6. 2112h AI Error Reaction Delay

Index	Subindex	Data Type	Access	PDO Mapping	Value Range	Default Value	Description
2112	0	UINT8	RO	No	4	4	Number of subindexes
	1	UINT16	RW		0-60000	1000	Input #1 error clear hysteresis
	2				Input #2 error clear hysteresis		
	3				Input #3 error clear hysteresis		
	4				Input #4 error clear hysteresis		

3.4.7. 2020h DI Pull Up Down Mode 1 Input Line

Index	Subindex	Data Type	Access	PDO Mapping	Value Range	Default Value	Description
2020	0	UINT8	RO	No	4	4	Number of subindexes
	1		RW		0-no pull	0	Input #1 pull up / down selection
	2		1 – PU		Input #2 pull up / down selection		
	3		2 – PD		Input #3 pull up / down selection		
	4		Input #4 pull up / down selection				

3.4.8. 3340h Motor Control Input Source

Index	Subindex	Data Type	Access	PDO Mapping	Value Range	Default Value	Description
3340	0	UINT8	RW	No	0-10	2	By default Universal Input. See Table 19

3.4.9. 3341h Motor Control Input Number

Index	Subindex	Data Type	Access	PDO Mapping	Value Range	Default Value	Description
3341	0	UINT8	RW	No	0-16	1	By default Input #1. See Table 19

3.4.10. 3350h Motor Direction Input Source

Index	Subindex	Data Type	Access	PDO Mapping	Value Range	Default Value	Description
3350	0	UINT8	RW	No	0-10	0	By default disabled. See Table 19

3.4.11. 3351h Motor Direction Input Number

Index	Subindex	Data Type	Access	PDO Mapping	Value Range	Default Value	Description
3351	0	UINT8	RW	No	0-16	1	By default disabled. See Table 19

3.4.12. 3360h Motor Enable Input Source

Index	Subindex	Data Type	Access	PDO Mapping	Value Range	Default Value	Description
3360	0	UINT8	RW	No	0-10	0	By default disabled. See Table 19

3.4.13. 3351h Motor Enable Input Number

Index	Subindex	Data Type	Access	PDO Mapping	Value Range	Default Value	Description
3361	0	UINT8	RW	No	0-16	1	By default disabled. See Table 19

3.4.14. 3510h Number of Pole Pairs

Index	Subindex	Data Type	Access	PDO Mapping	Value Range	Default Value	Description
3510	0	UINT8	RW	No	0-32	4	Number of pole pairs in the brushless motor

3.4.15. 3511h Position Detection

Index	Subindex	Data Type	Access	PDO Mapping	Value Range	Default Value	Description
3511	0	UINT8	RW	No	0, 1	0	Preferred rotor position detection method. Sensorless or Hall sensors. 0 – Hall sensors 1 – Sensorless

3.4.16. 3512h Commutation Sequence

Index	Subindex	Data Type	Access	PDO Mapping	Value Range	Default Value	Description
3512	0	UINT8	RW	No	0-5	0	Commutation sequence to use in case Hall sensor based position detection is in use. See tables on page 11.

3.4.17. 3513h Over Current Clear Time

Index	Subindex	Data Type	Access	PDO Mapping	Value Range	Default Value	Description
3513	0	UINT16	RW	No	0-60000	5000	The interval for trying to clear over current status.

3.4.18. 3514h RPM Pickup Style

Index	Subindex	Data Type	Access	PDO Mapping	Value Range	Default Value	Description
3514	0	UINT8	RW	No	0,1	0	0 – Standard 1 – Use Hall A signal

3.4.19. 3515h PWM Frequency

Index	Subindex	Data Type	Access	PDO Mapping	Value Range	Default Value	Description
3515	0	UINT16	RW	No	0-80	20	PWM frequency to use in motor driving in kHz.

3.4.20. 3610h Speed Regulator P Gain

Index	Subindex	Data Type	Access	PDO Mapping	Value Range	Default Value	Description
3610	0	FLOAT32	RW	No	0-1000	1	Motor speed/velocity controller P gain

3.4.21. 3611h Speed Regulator I Gain

Index	Subindex	Data Type	Access	PDO Mapping	Value Range	Default Value	Description
3611	0	FLOAT32	RW	No	0-1000	0	Motor speed/velocity controller I gain

3.4.22. 3612h Speed Regulator Open Loop Gain

Index	Subindex	Data Type	Access	PDO Mapping	Value Range	Default Value	Description
3612	0	FLOAT32	RW	No	0-1000	1	Motor speed/velocity controller Open Loop gain

3.4.23. 3613h Current Regulator P Gain

Index	Subindex	Data Type	Access	PDO Mapping	Value Range	Default Value	Description
3613	0	FLOAT32	RW	No	0-1000	1	Motor torque/current controller P gain

3.4.24. 3614h Current Regulator I Gain

Index	Subindex	Data Type	Access	PDO Mapping	Value Range	Default Value	Description
3614	0	FLOAT32	RW	No	0-1000	0	Motor torque/current controller I gain

3.4.25. 3710h Ramp Up Time

Index	Subindex	Data Type	Access	PDO Mapping	Value Range	Default Value	Description
3710	0	UINT16	RW	No	0-65000	100	Motor speed/velocity target value ramp up time in milliseconds

3.4.26. 3711h Ramp Down Time

Index	Subindex	Data Type	Access	PDO Mapping	Value Range	Default Value	Description
3711	0	UINT16	RW	No	0-65000	100	Motor speed/velocity target value ramp down time in milliseconds

3.4.27. 3713h Output PWM Ramp Time

Index	Subindex	Data Type	Access	PDO Mapping	Value Range	Default Value	Description
3713	0	UINT32	RW	No	0-65000	10	Sensorless startup unit time

3.4.28. 3714h Startup Period Target

Index	Subindex	Data Type	Access	PDO Mapping	Value Range	Default Value	Description
3714	0	UINT32	RW	No	0-65000	250	Sensorless startup target period time

3.4.29. 3715h Startup Period Target

Index	Subindex	Data Type	Access	PDO Mapping	Value Range	Default Value	Description
3715	0	UINT32	RW	No	0-65000	1500	Sensorless startup initial period time

3.4.30. 3716h Initial Maximum PWM Drive

Index	Subindex	Data Type	Access	PDO Mapping	Value Range	Default Value	Description
3716	0	UINT32	RW	No	0-32767	4800	Sensorless startup initial maximum PWM drive (valid only during initial open loop speed ramp up)

3.4.31. 3717h Overcurrent VDS

Index	Subindex	Data Type	Access	PDO Mapping	Value Range	Default Value	Description
3717	0	UINT8	RW	No	0-4	4	Gate driver chip's overcurrent VDS setting. See Table 7

3.4.32. 2450h PID Tolerance

Index	Subindex	Data Type	Access	PDO Mapping	Value Range	Default Value	Description
2450	0	INT16	RW	No	0-100	10	Additional PID controller tolerance

3.4.33. 2451h PID Integral Gain

Index	Subindex	Data Type	Access	PDO Mapping	Value Range	Default Value	Description
2451	0	INT16	RW	No	0-100	10	Additional PID controller integral gain

3.4.34. 2452h PID Derivative Gain

Index	Subindex	Data Type	Access	PDO Mapping	Value Range	Default Value	Description
2452	0	INT16	RW	No	0-100	10	Additional PID controller derivative gain

3.4.35. 2453h PID Target Source

Index	Subindex	Data Type	Access	PDO Mapping	Value Range	Default Value	Description
2453	0	UINT8	RW	No	0-10	0	By default disabled. See Table 19

3.4.36. 2454h PID Target Number

Index	Subindex	Data Type	Access	PDO Mapping	Value Range	Default Value	Description
4254	0	UINT8	RW	No	0-16	1	By default disabled. See Table 19

3.4.37. 2455h PID Feedback Source

Index	Subindex	Data Type	Access	PDO Mapping	Value Range	Default Value	Description
2455	0	UINT8	RW	No	0-10	0	By default disabled. See Table 19

3.4.38. 2456h PID Feedback Number

Index	Subindex	Data Type	Access	PDO Mapping	Value Range	Default Value	Description
4256	0	UINT8	RW	No	0-16	1	By default disabled. See Table 19

3.4.39. 2457h PID Control Response

Index	Subindex	Data Type	Access	PDO Mapping	Value Range	Default Value	Description
4257	0	UINT8	RW	No	0-3	0	Additional PID controller response selection

3.4.40. 2460h PID Output FV

Index	Subindex	Data Type	Access	PDO Mapping	Value Range	Default Value	Description
4260	0	INT16	RO	No	0-1000	0	Additional PID controller output FV

3.4.41. 2500h EC Extra Received PV

Index	Subindex	Data Type	Access	PDO Mapping	Value Range	Default Value	Description	
2500	0	UINT8	RO	Yes	6	6	Number of subindexes	
	1	INT16	RW			INT16	0	Extra received PV 1
	2							Extra received PV 2
	3							Extra received PV 3
	4							Extra received PV 4
	5							Extra received PV 5
	6							Extra received PV 6

3.4.42. 2502h EC Decimal Digits PV

Index	Subindex	Data Type	Access	PDO Mapping	Value Range	Default Value	Description
2502	0	UINT8	RO	No	6	6	Number of subindexes
	1		RW		0-3	1	Extra received PV 1 decimal digits
	2						Extra received PV 2 decimal digits
	3						Extra received PV 3 decimal digits
	4						Extra received PV 4 decimal digits
	5						Extra received PV 5 decimal digits
	6						Extra received PV 6 decimal digits

3.4.43. 2520h EC Scaling 1 PV

Index	Subindex	Data Type	Access	PDO Mapping	Value Range	Default Value	Description	
2520	0	UINT8	RO	No	6	6	Number of subindexes	
	1	INT16	RW			INT16	0	EC 1 process value scaler 1
	2							EC 2 process value scaler 1
	3							EC 3 process value scaler 1
	4							EC 4 process value scaler 1
	5							EC 5 process value scaler 1
	6							EC 6 process value scaler 1

3.4.44. 2522h EC Scaling 2 PV

Index	Subindex	Data Type	Access	PDO Mapping	Value Range	Default Value	Description	
2522	0	UINT8	RO	No	6	6	Number of subindexes	
	1	INT16	RW			INT16	0	EC 1 process value scaler 2
	2							EC 2 process value scaler 2
	3							EC 3 process value scaler 2
	4							EC 4 process value scaler 2
	5							EC 5 process value scaler 2
	6							EC 6 process value scaler 2

3.4.45. 4100h Math 1 Input Source

Index	Subindex	Data Type	Access	PDO Mapping	Value Range	Default Value	Description
4100	0	UINT8	RO	No	2	2	Number of subindexes
	1		RW		0-10	0	By default disabled. See Table 19
	2						

3.4.46. 4101h Math 1 Input Number

Index	Subindex	Data Type	Access	PDO Mapping	Value Range	Default Value	Description
4101	0	UINT8	RO	No	2	2	Number of subindexes
	1		RW		0-16	1	By default disabled. See Table 19
	2						

3.4.47. 4102h Math 1 Gain

Index	Subindex	Data Type	Access	PDO Mapping	Value Range	Default Value	Description
4102	0	INT8	RW	No	-100-100	100	Math 1 Gain setting

3.4.48. 4150h Math 1 Operator

Index	Subindex	Data Type	Access	PDO Mapping	Value Range	Default Value	Description
4150	0	UINT8	RW	No	0-14	9	Math 1 Operator setting. See Table 18

3.4.49. 4160h Math 1 Offset Source

Index	Subindex	Data Type	Access	PDO Mapping	Value Range	Default Value	Description
4160	0	UINT8	RW	No	0-10	0	By default disabled. See Table 19

3.4.50. 4161h Math 1 Offset Number

Index	Subindex	Data Type	Access	PDO Mapping	Value Range	Default Value	Description
4161	0	UINT8	RW	No	0-16	1	By default disabled. See Table 19

3.4.51. 4162h Math 1 Offset Polarity

Index	Subindex	Data Type	Access	PDO Mapping	Value Range	Default Value	Description
4162	0	UINT8	RW	No	0, 1	0	0 – Positive 1 – Negative

3.4.52. 4200h Math 2 Input Source

Index	Subindex	Data Type	Access	PDO Mapping	Value Range	Default Value	Description
4200	0	UINT8	RO	No	2	2	Number of subindexes
	1		RW		0-10	0	By default disabled. See Table 19
	2						

3.4.53. 4201h Math 2 Input Number

Index	Subindex	Data Type	Access	PDO Mapping	Value Range	Default Value	Description
4201	0	UINT8	RO	No	2	2	Number of subindexes
	1		RW		0-16	1	By default disabled. See Table 19
	2						

3.4.54. 4250h Math 2 Operator

Index	Subindex	Data Type	Access	PDO Mapping	Value Range	Default Value	Description
4250	0	UINT8	RW	No	0-14	9	Math 2 Operator setting. See Table 18

3.4.55. 5010h Constant Field Value

Index	Subindex	Data Type	Access	PDO Mapping	Value Range	Default Value	Description	
5010	0	UINT8	RO	No	12	12	Number of subindexes User modifiable constant values to be used in custom control application.	
	1	FLOAT32	RW		No	FLOAT32		0.0
	2							1.0
	3							10.0
	4							20.0
	5							30.0
	6							40.0
	7							50.0
	8							60.0
	9							70.0
	10							80.0
	11							90.0
	12							100.0

3.4.56. 5020h Power Supply FV

Index	Subindex	Data Type	Access	PDO Mapping	Value Range	Default Value	Description
5020	0	FLOAT32	RO	Yes	FLOAT32	0	Measured power supply voltage

3.4.57. 5030h CPU Temperature FV

Index	Subindex	Data Type	Access	PDO Mapping	Value Range	Default Value	Description
5030	0	FLOAT32	RO	Yes	FLOAT32	0	Measured CPU internal temperature

3.4.58. 5040h FD Field Value

Index	Subindex	Data Type	Access	PDO Mapping	Value Range	Default Value	Description	
5040	0	UINT8	RO	No	3	3	Number of subindexes	
	1	FLOAT32			No	FLOAT32	0	FD Field Value 1
	2							FD Field Value 2
	3							FD Field Value 3

3.4.59. 5041h FD Set Threshold

Index	Subindex	Data Type	Access	PDO Mapping	Value Range	Default Value	Description	
5041	0	UINT8	RO	No	3	3	Number of subindexes	
	1	UINT16	RW		No	UINT16	1100	FD Set Threshold 1 (Temperature SET)
	2						500	FD Set Threshold 2 (VPS SET High)
	3						90	FD Set Threshold 3 (VPS SET Low)

3.4.60. 5042h FD Clear Threshold

Index	Subindex	Data Type	Access	PDO Mapping	Value Range	Default Value	Description
5042	0	UINT8	RO	No	3	3	Number of subindexes
	1	UINT16	RW		UINT16	850	FD Set Threshold 1 (Temperature CLR)
	2					480	FD Set Threshold 2 (VPS CLR High)
	3					120	FD Set Threshold 3 (VPS CLR Low)

3.4.61. 5050h FD Enable 3 Faults

Index	Subindex	Data Type	Access	PDO Mapping	Value Range	Default Value	Description
5050	0	UINT8	RW	No	0-7	7	Enable diagnostics: bit 0 – VPS bit 1 – CPU temperature

3.4.62. 5051h FD Error Response Delay

Index	Subindex	Data Type	Access	PDO Mapping	Value Range	Default Value	Description
5051	0	UINT8	RO	No	3	3	Number of subindexes
	1	INT16	RW		0-600	10	FD Error response delay 1 (Temperature)
	2					10	FD Error response delay 2 (VPS)
	3					10	FD Error response delay 3

3.4.63. 5060h Control Logic Output

Index	Subindex	Data Type	Access	PDO Mapping	Value Range	Default Value	Description
5060	0	UINT8	RO	Yes	15	15	Number of subindexes
	1	FLOAT32			FLOAT32	0	Control Logic Block's output values. See also Figure 12 – Special data available in Control Logic Data
	2				0		
	3				0		
	4				0		
	5				0		
	6				0		
	7				0		
	8				0		
	9				0		
	10				0		
	11				0		
	12				0		
	13				0		
	14				0		
	15				0		

3.4.64. 5061h Control Logic Output INT32

Index	Subindex	Data Type	Access	PDO Mapping	Value Range	Default Value	Description
5061	0	UINT8	RO	Yes	15	15	Number of subindexes
	1	INT32			INT32	0	Control Logic Block's output values in INTEGER32 format. See also Figure 12 – Special data available in Control Logic Data
	2				0		
	3				0		
	4				0		
	5				0		
	6				0		
	7				0		
	8				0		
	9				0		
	10				0		
	11				0		
	12				0		
	13				0		
	14				0		
	15				0		

3.4.65. 5555h Start In Operational Mode

Index	Subindex	Data Type	Access	PDO Mapping	Value Range	Default Value	Description
5555	0	UINT8	RW	No	0-3	0	0 – No action, wait NMT commands 1 – Start directly in operational mode 2 – Start in operational mode and send NMT for starting also other devices 3 – Start in operational mode and set PDS FSA to Enabled Mode.

3.4.66. 5556h Start In Operational NMT Delay

Index	Subindex	Data Type	Access	PDO Mapping	Value Range	Default Value	Description
5556	0	UINT16	RW	No	0-65000	1000	Delay in milliseconds before sending the NMT message in case object 5555h is set to '2'.

APPENDIX A - TECHNICAL SPECIFICATION

Technical Specifications: *Specifications are indicative and subject to change. Actual performance will vary depending on the application and operating conditions. Users should satisfy themselves that the product is suitable for use in the intended application. All our products carry a limited warranty against defects in material and workmanship. Please refer to our Warranty, Application Approvals/Limitations and Return Materials Process as described on www.axiomatic.com/service.html.*

Input Specifications

Power Supply Input - Nominal	12 or 24Vdc nominal (9...36Vdc)
Reverse Polarity Protection	Provided up to -80Vdc
Surge Protection	Provided
Under-voltage Protection	Built-in
Signal Inputs	<p>Three (3) universal inputs are user selectable as: Voltage; Current; Resistive; PWM; Frequency; or Digital types. One (1) input is user configurable as: Voltage; Current; or Resistive types.</p> <p>12-bit Analog to Digital resolution Protected against short to ground Amplitude: up to +Vsupply Input properties are user configurable. Refer to Table 28.0. Any input on the controller can be coded into a Proprietary B message that can be sent to the CAN network.</p>
Analog/Digital Ground	Four (4) are provided.
Motor Feedback	<p>Hall Effect Sensor Standard open collector/drain hall input type +5V supply and ground connection pins are provided. 10K Pullup to +5V per input Sensorless operation is also available.</p>

Table 28.0 Inputs to AX100261 (Up to 4 user selectable inputs)

Inputs	Description
Universal Signal Inputs 1-3	<p>Up to 3 universal signal inputs are available.</p> <p>Voltage Input Types: 0...5VDC or 0...10VDC 1mV resolution, accuracy +/- 1% error The offset is in millivolts and the resolution is mV/bit, when sending a CAN message. Input measurement setpoints are interpreted in volts.</p> <p>Current Input Types: 4...20mA or 0...20mA 1uA resolution, accuracy +/- 1% error The offset is in microamps and the resolution is uA/bit, when sending a CAN message. Input measurement setpoints are interpreted in milliamps. Current sense resistor 249Ω</p> <p>Resistive Type with Auto Ranging and Self Calibration: 20 Ω to 250K Ω, +/- 1% error</p> <p>PWM Input Type: PWM Signal Frequency: 1.3kHz – 15kHz PWM Duty Cycle: 0 to 100% 0.01% resolution, accuracy +/- 1% error</p> <p>Frequency Input Type: 1.3kHz to 15kHz</p> <p>Digital Input Types: Normal, Inverse and Latched Active High with 10K Pullup resistor or Active Low with 10K Pulldown resistor These inputs can be used as an enable or direction command for the controller. The input accepted is active high (switch is connected to a +V signal when ON).</p>
Signal Input 4	<p>Signal Input 4 is user selectable as:</p> <p>Voltage Input Types: 0...5VDC or 0...10VDC 1mV resolution, accuracy +/- 1% error The offset is in millivolts and the resolution is mV/bit, when sending a CAN message. Input measurement setpoints are interpreted in volts.</p> <p>Current Input Types: 4...20mA or 0...20mA 1uA resolution, accuracy +/- 1% error The offset is in microamps and the resolution is uA/bit, when sending a CAN message. Input measurement setpoints are interpreted in milliamps. Current sense resistor 249Ω</p> <p>Resistive Type with Auto Ranging and Self Calibration: 20 Ω to 250K Ω, +/- 1% error</p>

Output Specifications

Output to Motor	<p>3 phase, H-bridge, current sensing per each phase 6A @ 24VDC nominal continuous 6A @ 12VDC nominal continuous</p> <p>100W nominal power rating Sensorless or hall sensor operation</p> <p>Overcurrent protection is provided at 12A. Short circuit protection is provided. The maximum rated speed and motor rated current are configurable to suit individual motor specifications.</p>
Motor Stop	Shut off with or without ramping
Motor Direction	Motor direction command can be mapped to any input or come from the CAN bus.
Motor Control Mode	<p>Flexible control is provided by user configurable parameters for</p> <ul style="list-style-type: none"> ➤ Open loop speed ➤ Closed loop speed; ➤ Current control; ➤ Position control; or ➤ PID control. <p>The control input to drive the motor can be mapped to any of the universal inputs or the controller can respond to messages from a CAN bus.</p>
Thermal Protection	Thermal protection is built-in and configurable.
Reference Voltage	<p>1 +5V, +/- 0.5%, 200 mA</p> <p>Four connection points are provided for each of installation.</p>

General Specifications

Microprocessor	TI TMS320F28069, 32-bit, 256 KB flash program memory, 100 KB RAM
Motor Control	Standard embedded software is provided.
Diagnostics	There are 3 Diagnostic blocks that can be configured to monitor various parameters of the Controller.
Simulink®	The product was developed with Simulink®. Simulink® is a model-based design tool from Mathworks®. Refer to the User Manual <i>Axiomatic Hardware Interface Library for Mathworks Simulink</i> for details.
User Interface	<p>Electronic Assistant® for <i>Windows</i> operating systems It comes with a royalty-free license for use.</p> <p>The Axiomatic Electronic Assistant® requires an USB-CAN converter to link the device's CAN port to a <i>Windows</i>-based PC for initial configuration. Order the EA and Axiomatic USB-CAN as a kit (P/N AX070502), which includes all interconnecting cables.</p>
Flashing over CAN	The controller software can be reflashed over the CAN connection using the EA.
CAN port	1 CAN port (SAE J1939) (CANopen® on request.)
Weight	0.60 lb. (0.27 kg)
Operating Conditions	-40°C to +125°C (-40°F to 257°F)
Protection Rating	IP67
Enclosure and Dimensions	<p>High Temperature Nylon housing - Deutsch IPD PCB Enclosure (EEC-325X4B) 4.62 x 5.24 x 1.43 inches 117.42 x 133.09 x 36.36 mm (W x L x H excluding mating plugs)</p>
Electrical Connections	<p>Deutsch DTM series 24 pin receptacle (DTM13-12PA-12PB-R008) <i>Refer to Installation Instructions</i> section.</p>
Mating Plug Kit	A mating plug kit comprised of all mating connectors is available as P/N: PL-DTM06-12SA-12SB. It includes: Deutsch DTM06-12SA; DTM06-12SB: 2 wedgelocks WM12S; and 24 contacts 0462-201-20141. 20 AWG wire is recommended for use with contacts 0462-201-20141.
Mounting	<p>The motor controller should be mounted as close to the battery and/or the motor as possible. Install the unit with appropriate space available for servicing and for adequate wire harness access and strain relief.</p> <p>Mounting holes sized for ¼ inch or M6 bolts. The bolt length will be determined by the end-user's mounting plate thickness. The mounting flange of the controller is 0.63 inches (16 mm) thick. If the module is mounted without an enclosure, it should be mounted vertically with connectors facing left and right to reduce likelihood of moisture entry. The CAN wiring is considered intrinsically safe. The power wires are not considered intrinsically safe and so in hazardous locations, they need to be located in conduit or conduit trays at all times. The module must be mounted in an enclosure in hazardous locations for this purpose.</p> <p>All field wiring should be suitable for the operating temperature range.</p>



OUR PRODUCTS

Actuator Controls
Battery Chargers
CAN bus Controls, Gateways
CAN/Wifi, CAN/Bluetooth
CAN/Ethernet
Current Converters
DC/DC Power Converters
DC Voltage/Current Signal Converters
Engine Temperature Scanners
Ethernet/CAN Converters
Fan Drive Controllers
Hydraulic Valve Controllers
I/O Controls
LVDT Simulators
Machine Controls
Motor Controls
PID Controls
Position Sensors, Angle Measurement Inclinometers, Gyroscopes
Power Supplies
PWM Signal Converters/Isolators
Resolver Signal Conditioners
Service Tools
Signal Conditioners
Strain Gauge CAN Controls
Surge Suppressors

OUR COMPANY

Axiomatic provides electronic machine controls, components, and systems to the off-highway, commercial vehicle, electric vehicle, power generator set, material handling, renewable energy and industrial OEM markets.

We provide efficient, innovative solutions that focus on adding value for our customers.

We emphasize service and partnership with our customers, suppliers, and employees to build long term relationships and mutual trust.

QUALITY DESIGN AND MANUFACTURING

Axiomatic is an ISO 9001:2015 registered facility.

SERVICE

All products to be returned to Axiomatic require a Return Materials Authorization Number (RMA#).

Please provide the following information when requesting an RMA number:

- Serial number, part number
- Axiomatic invoice number and date
- Hours of operation, description of problem
- Wiring set up diagram, application
- Other comments as needed

When preparing the return shipping paperwork, please note the following. The commercial invoice for customs (and packing slip) should state the harmonized international HS (tariff code), valuation and return goods terminology, as shown in italics below. The value of the units on the commercial invoice should be identical to their purchase price.

*Goods Made In Canada (or Finland)
Returned Goods for Warranty Evaluation, HS: 9813.00
Valuation Identical Goods
Axiomatic RMA#*

WARRANTY, APPLICATION APPROVALS/LIMITATIONS

Axiomatic Technologies Corporation reserves the right to make corrections, modifications, enhancements, improvements, and other changes to its products and services at any time and to discontinue any product or service without notice. Customers should obtain the latest relevant information before placing orders and should verify that such information is current and complete. Users should satisfy themselves that the product is suitable for use in the intended application. All our products carry a limited warranty against defects in material and workmanship. Please refer to our Warranty, Application Approvals/Limitations and Return Materials Process as described on www.axiomatic.com/service.html.

CONTACTS

Axiomatic Technologies Corporation
5915 Wallace Street
Mississauga, ON
CANADA L4Z 1Z8
TEL: +1 905 602 9270
FAX: +1 905 602 9279
www.axiomatic.com

Axiomatic Technologies Oy
Höytämöntie 6
33880 Lempäälä
FINLAND
TEL: +358 103 375 750
FAX: +358 3 3595 660
www.axiomatic.fi