



USER MANUAL UMAX102100

40A DC MOTOR CONTROLLER WITH CAN, SAE J1939

USER MANUAL

P/N: AX102100

In Europe:
Axiomatic Technologies Oy
Höytämöntie 6
33880 LEMPÄÄLÄ - Finland
Tel. +358 3 3595 600
Fax. +358 3 3595 660
www.axiomatic.fi

In North America:
Axiomatic Technologies Corporation
5915 Wallace Street
Mississauga, ON Canada L4Z 1Z8
Tel. 1 905 602 9270
Fax. 1 905 602 9279
www.axiomatic.com

VERSION HISTORY

Version	Date	Author	Modification
1.0.0.	August 25, 2021	Antti Keränen	Initial Version.

ACRONYMS

ACK	Positive Acknowledgement (from SAE J1939 standard)
BATT +/-	Battery positive (a.k.a. Vps) or Battery Negative (a.k.a. GND)
DIN	Digital Input used to measure active high or low signals
DM	Diagnostic Message (from SAE J1939 standard)
DTC	Diagnostic Trouble Code (from SAE J1939 standard)
EA	Electronic Assistant [®] , p/n AX070502 (A Service Tool for Axiomatic ECUs)
ECU	Electronic Control Unit (from SAE J1939 standard)
GND	Ground reference (a.k.a. BATT-)
I/O	Inputs and Outputs
MAP	Memory Access Protocol
NAK	Negative Acknowledgement (from SAE J1939 standard)
PDU1	A format for messages that are to be sent to a destination address, either specific or global (from SAE J1939 standard)
PDU2	A format used to send information that has been labeled using the Group Extension technique, and does not contain a destination address.
PGN	Parameter Group Number (from SAE J1939 standard)
PropA	Message that uses the Proprietary A PGN for peer-to-peer communication
PropB	Message that uses a Proprietary B PGN for broadcast communication
PWM	Pulse Width Modulation
RPM	Rotations per Minute
SPN	Suspect Parameter Number (from SAE J1939 standard)
TP	Transport Protocol
UIN	Universal input used to measure voltage, current, frequency or digital inputs
Vps	Voltage Power Supply (a.k.a. BATT+)
%dc	Percent Duty Cycle (Measured from a PWM input)

TABLE OF CONTENTS

1.2.	Input Function Blocks	11
1.3.	Input Filtering	14
1.4.	Output Function Blocks	14
1.5.	Diagnostic Function Blocks	19
1.6.	PID Control Function Block	23
1.7.	Lookup Table Function Block	24
1.8.	Programmable Logic Function Block	25
1.9.	Math Function Block	26
1.11.	DTC React	28
1.12.	CAN Transmit Message Function Block	28
1.12.1.	CAN Transmit Message Setpoints	28
1.12.2.	CAN Transmit Signal Setpoints	29
1.13.	CAN Receive Function Block	29
1.14.	Available Control Sources	30
3.2.	NAME, Address and Software ID	35
4.1.	J1939 Network Parameters	37
4.2.	Motor Drive Setpoints	38
4.3.	Universal Input Setpoints	39
4.4.	Digital Input Setpoints	40
4.5.	Proportional Output Drive Setpoints	41
4.6.	Constant Data List Setpoints	43
4.7.	Variable Data List Setpoints	44
4.8.	PID Control	45
4.9.	Lookup Table	46
4.10.	Programmable Logic	48
4.11.	Math Function Block	50
4.12.	Small Math Function Block	52
4.13.	CAN Transmit Setpoints	53
4.14.	CAN Receive Setpoints	55
4.15.	DTC React	56
4.16.	General Diagnostics Options	57
4.17.	Diagnostics Blocks	58
APPENDIX A - TECHNICAL SPECIFICATION		A-1

Table 1 – Combined enable and direction signals 10

Table 2 – Universal Input Sensor Type Options 11

Table 3 – Debounce Time Options 11

Table 4 – Software Debounce Filter Times 12

Table 5 – Pullup/Pulldown Resistor Options 12

Table 6 – Active High/Low Options 13

Table 7 – Digital Input Sensor Type versus Input State 13

Table 8 – Filter Type Options 14

Table 9 – Output Type Options for Proportional Output 15

Table 10 – Digital Response Options 15

Table 11 – Enable Response Options 18

Table 12 – Override Response Options 18

Table 13 – Fault Response Options 18

Table 14 – Lamp Set by Event in DM1 Options 21

Table 15 – FMI for Event Options 22

Table 16 – Low Fault FMIs and corresponding High Fault FMIs 22

Table 17 – PID Response Options 23

Table 18 – X-Axis Type Options 24

Table 19 – PointN – Response Options 25

Table 20 – Table X – Condition Y, Operator Options 26

Table 21 – Table X – Conditions Logical Operator Options 26

Table 22 – Math function X Operator Options 27

Table 23 – Available Control Sources and Numbers 31

Table 24 – AX102100 Connector Pin-Out 33

Table 25 – J1939 Network Setpoints 37

Table 26 – Motor Drive Setpoints 38

Table 27 – Universal Input Setpoints 39

Table 28 – Digital Input Setpoints 40

Table 29 – Proportional Output Setpoints 42

Table 30 – Variable Data Setpoints 44

Table 31 – Programmable Logic Setpoints 45

Table 32 – Lookup Table Setpoints 47

Table 33 – Programmable Logic Setpoints 49

Table 34 – Math Function Setpoints 51

Table 35 – Math Function Setpoints 52

Table 36 – CAN Transmit Message Setpoints 54

Table 37 – CAN Receive Setpoints 55

Table 38 – DTC React Setpoints 56

Table 39 – General Diagnostics Options Setpoints 57

Table 40 – Diagnostic Block Setpoints 60

Figure 1 – AX102100 Block Diagram 8

Figure 2 – Hotshot Digital Profile 16

Figure 3 – Double Minimum and Maximum Error Thresholds 20

Figure 4 – Analog source to Digital input 32

Figure 5 – AX102100 Dimensional Drawing 33

Figure 6 – Screen Capture of J1939 Setpoints 37

Figure 7 – Screen Capture of Motor Drive Setpoints 38

Figure 8 – Screen Capture of Universal Input Setpoints 39

Figure 9 – Screen Capture of Digital Input Setpoints 40

Figure 10 – Screen Capture of Proportional Output Setpoints 41

Figure 11 - Screen Capture of Constant Data List Setpoints 43

Figure 12 – Screen Capture of Variable Data List Setpoints 44

Figure 13 – Screen Capture of PID Control Setpoints 45

Figure 14 – Screen Capture of Lookup table Setpoints 46

Figure 15 – Screen Capture of Programmable Logic Setpoints 48

Figure 16 – Screen Capture of Math Function Block Setpoints 50

Figure 17 – Screen Capture of Small Math Function Block Setpoints 52

Figure 18 – Screen Capture of CAN Transmit Message Setpoints 53

Figure 19 – Screen Capture of CAN Receive Message Setpoints 55

Figure 20 – Screen Capture of DTC React Setpoints 56

Figure 21 – Screen Capture of General Diagnostics Options Setpoints 57

Figure 22 – Screen Capture of Diagnostic Block Setpoints 58

REFERENCES

J1939	Recommended Practice for a Serial Control and Communications Vehicle Network, SAE, April 2011
J1939/21	Data Link Layer, SAE, December 2010
J1939/71	Vehicle Application Layer, SAE, March 2011
J1939/73	Application Layer-Diagnostics, SAE, February 2010
J1939/81	Network Management, SAE, May 2003
TDAX102100	Technical Datasheet, 40A DC Motor Controller with CAN, Axiomatic Technologies 2021
UMAX07050x	User Manual V5.13.88, Electronic Assistant and USB-CAN, Axiomatic Technologies, May 2017

This document assumes the reader is familiar with the SAE J1939 standard. Terminology from the standard is used, but not described in this document.



NOTE: This product is supported by Electronic Assistant® V5.15.116.0 and higher.

1. Overview Of The Controller

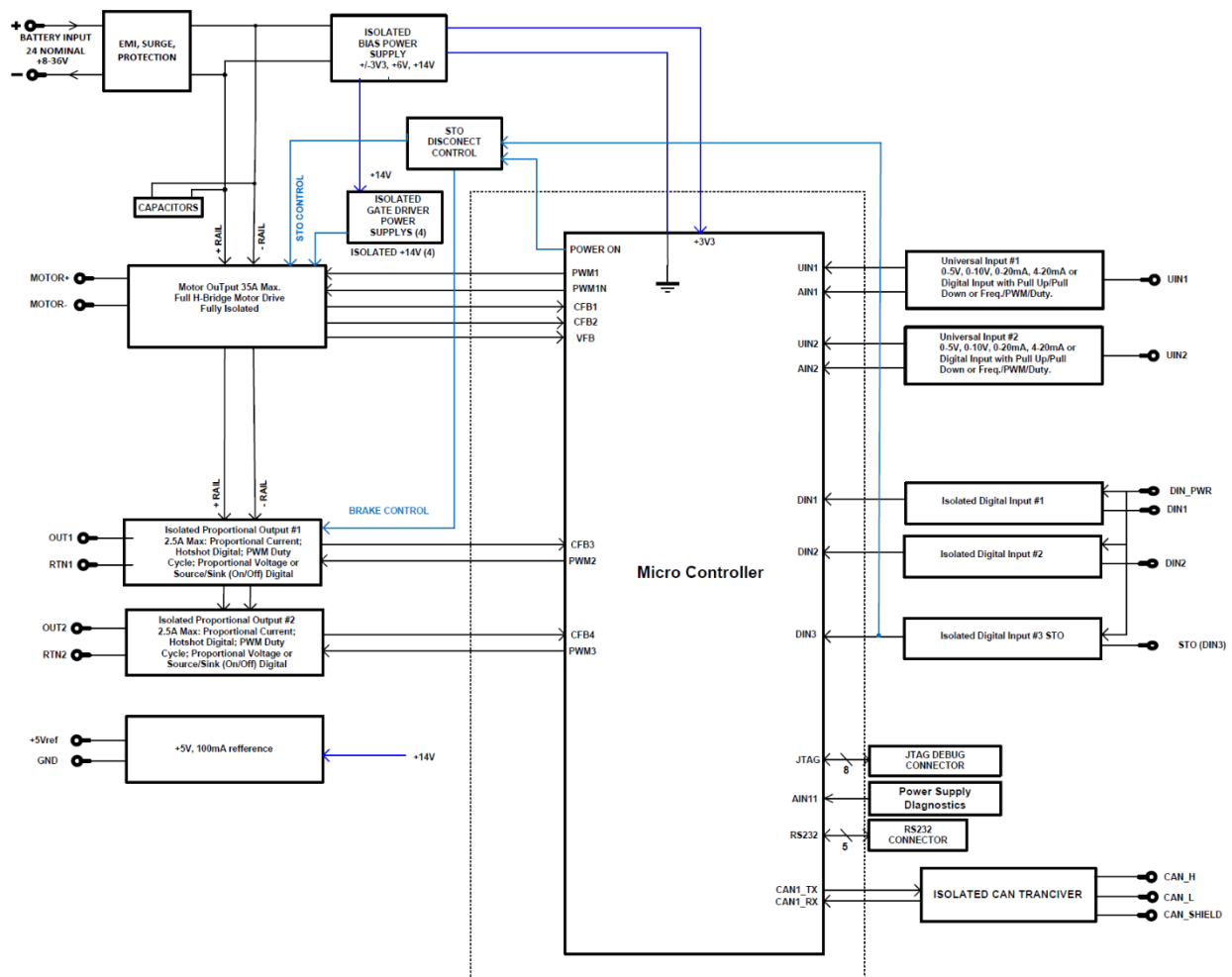

Figure 1 – AX102100 Block Diagram

The 40A DC Motor Controller is designed for versatile control of a DC motor or other load up to 40A current. In addition to the motor control output, there are two proportional current outputs, two universal inputs and three digital inputs. For the universal inputs, controller’s flexible circuit design gives the user a wide range of configurable input types. The sophisticated control algorithms allow the user to program the controller for a wide range of applications without the need for custom software.

The controller has two Universal inputs that can be configured to measure analog voltage or current, frequency/PMW or digital signal and three Digital inputs that are fixed to measure digital on/off signals. Measured input data can be sent to a SAE J1939 CAN or used to drive the outputs directly or through the configurable control algorithms.

The motor control output is of H-bridge type with capability of driving up to 40A continuous current through the load in both directions. The proportional outputs can be configured to source current signals up to 2A. Any of the outputs can be configured to use any of the on-board inputs as either a control signal or an enable signal as well as SAE J1939 CAN data.

A *Windows*-based Axiomatic Electronic Assistant® (EA) is used to configure the controller via an USB-CAN (AX070501) device. Configurable properties, EA setpoints, are outlined in chapter 4. Setpoint configuration can be saved in a file which can be used to easily program the same configuration into another 40A DC Motor Controller. Throughout this document EA setpoint names are referred with bolded text in double-quotes and the setpoint option is referred with italicized text in single-quotes. For example, “**Input Sensor Type**” setpoint set to option ‘*Voltage 0 to 5V*’.

In this document, the configurable properties of the ECU are divided into function blocks, namely Motor Control Function Block, Input Function Block, Output Function Block, Diagnostic Function Block, PID Control Function Block, Lookup Table Function Block, Programmable Logic Function Block, Math Function Block, DTC React Function Block, CAN Transmit Message Function Block and CAN Receive Message Function Block. These function blocks are presented in detail in next subchapters.

1.1. Motor Control Function Block

The motor control output can drive a motor or other load with continuous 40A current. The maximum instantaneous current can go beyond this limit.

The Motor Control setpoint group has settings for configuring how the motor control output is driven. The “**Output At Minimum Command**” is the output current maximum when a negative control value is fed into the output control block (one direction). The “**Output At Maximum Command**” is the equivalent with positive control values (to the other direction). Both setpoint values are given in milliamps and define the maximum motor current in each direction. The motor control algorithm will limit the output current if it tries to rise above these limits. In case current limiting is not desired, please set these two setpoints to larger current values than expected in the normal operation of the application.

In case the output current is not exceeding the “**Output At Minimum Command**” or “**Output At Maximum Command**” values, the motor drive (pwm dc in the motor output) follows the driving command linearly.

“**Output At Override Command**” is the output current limit when the override command is used by configuring the “**Override Source**” and “**Override Number**” setpoints.

“**Ramp Up**” and “**Ramp Down**” setpoints define the ramp duration for the motor drive to rise to its target or fall back to zero. Please note if the enable function is used to stop the motor, the ramp function is not applied because the enable functionality utilizes hardware feature for disabling the motor.

“**Control Source**” and “**Control Number**” setpoints define the control source for motor driving. The allowed values for these setpoints are listed in Table 23.

“**Direction Source**” and “**Direction Number**” define how the direction of motor current flow is controlled. “**Enable Source**” and “**Enable Number**” define the motor driving enable signal source. Both the direction and enable interpret the ‘control signal == 0’ as the one drive value and ‘control signal > 0’ the other.

“**Invert Motor Direction**” setpoint can be used to change the default direction of motor rotation.

“**Maximum Driver Stage Temperature**” and “**Drive Stage Temperature Hysteresis**” define the maximum value for the driver FET temperature and the hysteresis value for clearing this error condition. When the driver FETs exceed the configured maximum temperature, the motor driving is disabled until the temperature has fallen below the maximum value minus the configured hysteresis.

“**Motor Current Filter Constant**” setpoint defines the filter characteristic in motor current measurement. Smaller constant shows the peaks in the measured motor current, higher constants give more stable measurement results.

“**Stable Drive Values Before Changing Direction**” setpoint defines the number of target drive values that must have same sign (direction info) before the value is really applied to motor driving FETs. This will implement dead time while changing direction of rotation, during which the motor terminals are connected to GND via the driver FETs.

In case there is a need to use a combined direction and enable signaling, for example a CAN message containing both information, this is possible to configure by setting the “**Direction Source**” to *Control Not Used* and “**Enable Source**” to *Received CAN Message*. With this configuration, the received CAN message values are used as listed in Table 1.

0	<i>Disabled</i>
1	<i>Motor enabled in forward direction</i>
2	<i>Motor enabled in reverse direction</i>
3	<i>Reserved</i>

Table 1 – Combined enable and direction signals

The hardware over current limit for motor output is set to 75A. If the output current exceeds this limit, the hardware over current protection will disable the motor driving. The motor drive command will have to be set to zero for re-enabling the motor output again.



NOTE: The **Motor Output** has E-STOP functionality built-in. To enable the motor drive, the STO input 1 (Din #3) needs to be pulled low. Due to internal isolation, the pull-down needs to be done using **GNDB/Power GND** (Pin 11, see Table 24) Otherwise the motor driving output will remain disabled by hardware.



NOTE: The **Proportional Output #1** has E-STOP functionality built-in. To enable the output drive, the STO input 1 (Din #3) needs to be pulled low. Due to internal isolation, the pull-down needs to be done using **GNDB/Power GND** (Pin 11, see Table 24) Otherwise the Proportional Output #1 will remain disabled by hardware.

1.2. Input Function Blocks

The controller has altogether five inputs. The two Universal Inputs can be configured to measure voltage, current, frequency, pulse width (PWM) or digital signal. The three Digital Inputs are fixed to measure digital low / high voltage signals.



NOTE: Due to internal isolation, the **Universal Inputs** need to be referenced against the **Signal GND** (Pin 8, see Table 24) Otherwise the Universal Inputs wont provide measurement results.

NOTE: Due to internal isolation, the **Digital Inputs** are **active low** and need to be pulled down to **Power GND** (Pin 11, see Table 24) Otherwise the Digital Inputs wont provide measurement results.

Universal Input setpoint groups have the “**Input Sensor Type**” setpoint, which is used to configure input type. Selecting input type effects on other setpoints and how they are interpreted and should thus be selected first on this block. The input sensor types for Universal Inputs are listed in Table 2.

0	<i>Disabled</i>
12	<i>Voltage 0 to 5 V</i>
13	<i>Voltage 0 to 10 V</i>
20	<i>Current 0 to 20 mA</i>
21	<i>Current 4 to 20 mA</i>
40	<i>Frequency 0.5 to 50 Hz</i>
41	<i>Frequency 10 Hz to 1 kHz</i>
42	<i>Frequency 100 Hz to 10 kHz</i>
50	<i>PWM Low Frequency (<1kHz)</i>
51	<i>PWM High Frequency (>100Hz)</i>
60	<i>Digital (normal)</i>
61	<i>Digital (inverse)</i>
62	<i>Digital (latched)</i>

Table 2 – Universal Input Sensor Type Options

On Universal Inputs, analog voltage (i.e. 0-5V, 0-10V) or current (0-20mA, 4-20mA) signals go directly to a 12-bit analog-to-digital converter (ADC) on the processor. The voltage input is a high impedance input protected against shorts to GND or Vcc. In current mode, a 250Ω resistor is used to measure the input signal. Input signals should be connected to the GND reference pins provided on the connector, per Table 24.

0	<i>None</i>
1	<i>111ns</i>
2	<i>1.78us</i>
3	<i>14.22us</i>

Table 3 – Debounce Time Options

An additional software debounce filter can be used with Universal Input types when configured to detect digital signals for filtering the inputs using longer time constants than with the default debounce filter. The available software implemented debounce times are listed in Table 4.

0	<i>0ms</i>
1	<i>10ms</i>
2	<i>20ms</i>
3	<i>40ms</i>
4	<i>100ms</i>
5	<i>200ms</i>
6	<i>400ms</i>
7	<i>1000ms</i>

Table 4 – Software Debounce Filter Times

Frequency/RPM or Pulse Width Modulated (PWM) “**Input Sensor Type**” options connect an input to 16-bit timer pin on the processor. “**Debounce Time**” setpoint is used to select an input capture filter for the timer pin in question.

The “**Pulses/Units Per Revolution**” setpoint can be used with all input types. If this setpoint is set to a value greater than zero, then the input data will be multiplied by this value, resulting the input to be read in rotations-per-minute (RPM). This feature can be used for scaling the measured input value to RPM reading without having to use a lookup table. If this setpoint is set to zero, the inputs are measured and reported using the corresponding units (volts, milliamps, hertz...).

Universal Inputs have all available three Digital “**Input Sensor Type**” options: Normal, Inverse and Latched. With digital input sensor types, the input measurement is given, either 1 (ON) or 0 (OFF). The Universal inputs measure digital voltage with 3V threshold.

On Frequency, PWM and digital input modes 22kΩ pull-up or pull-down resistors can be enabled or disabled by setting the value of the “**Pullup/Pulldown Resistor**” setpoint. Setpoint options are given in Table 5. By default, pull-down resistors are enabled for all inputs.

0	<i>Pullup/down Off</i>
1	<i>22 kΩ Pullup</i>
2	<i>22 kΩ Pulldown</i>

Table 5 – Pullup/Pulldown Resistor Options

“**Active High/Active Low**” setpoint is used to configure how signal high and low are interpreted. Setpoint options are given in Table 6. By default, all inputs are selected to be Active High, which means that signal high is interpreted as 1(ON) and signal low as 0(OFF).

0	Active High
1	Active Low

Table 6 – Active High/Low Options

Table 7 shows the effect of different digital input types on input signal measurement interpretation with recommended “**Pullup/Pulldown Resistor**” and “**Active High/Low**” combinations. Fault diagnostics are not available for digital input types.

Input Sensor Type		Pulldown Active High	Pullup Active Low	Input measured (state)
6	<i>Digital (normal)</i>	High	Low or Open	1 (ON)
		Low or Open	High	0 (OFF)
61	<i>Digital (inverse)</i>	High or Open	Low	1 (ON)
		Low	High or Open	0 (OFF)
62	<i>Digital (latched)</i>	High to Low	Low to High	0 (no change)
		Low to High	High to Low	1 (state change)

Table 7 – Digital Input Sensor Type versus Input State

The “**Minimum Range**” and “**Maximum Range**” setpoints are used to define range of the signal input outputs as a control source. For example, if “**Maximum Range**” is set to 4V for an input, the control signal is saturated at 4V if input signal rises above 4V. The “**Minimum Range**” and “**Maximum Range**” setpoints are interpreted in input types units, thus they should be re-adjusted after editing “**Input Sensor Type**”.

Software filters can be applied to the measured input signal. Setpoints “**Software Filter Type**” and “**Software Filter Constant**” are used to configure the software filter. By default, no filter is applied to the signal. Software filtering is described in detail in section 0 below.

1.2.1. Digital Inputs

The controller has three digital inputs that are implemented as active low type. The digital inputs don’t have as many setpoints for configuration as the Universal Inputs have, however there is some configurability.

The “**Input Sensor Type**” setpoint allows to select between different input types as listed in Table 7 above. There is also “**Software Debounce Filter Time**” available, functionality is identical to Universal Inputs’ software debounce filtering. The “**Active High/Active Low**” setpoint defines whether a high or low input reading is interpreted as digital high in the other function blocks.

Please note that changing the Din #3 (STO input) active high/low setting does not affect the STO functionality which will remain active low independent of the configuration.

1.3. Input Filtering

Measured input data from both universal and analog inputs can be filtered to form desired CAN message data. Input filters are configured with “**Filter Type**” and “**Filter Constant**” setpoints. Filters are configured for each input individually.

0	<i>No Filtering</i>
1	<i>Moving Average</i>
2	<i>Repeating Average</i>

Table 8 – Filter Type Options

“**Filter Type**” setpoint defines the type of software filter used. Setpoint options are ‘*No Filtering*’, ‘*Moving Average*’ and ‘*Repeating Average*’. The ‘*No Filtering*’ option applies no filtering to the measured input data. The ‘*Moving Average*’ option applies the transfer function below to the measured input data, where $Value_N$ is the current value of the CAN message data, $Value_{N-1}$ is the previous CAN message data and Filter Constant is the value of the “**Filter Constant setpoint**”.

Equation 1 - Moving Average Transfer Function:

$$Value_N = Value_{N-1} + \frac{(Input - Value_{N-1})}{Filter\ Constant}$$

Equation 2 - Repeating Average Transfer Function:

$$Value = \frac{\sum_0^N Input_N}{N}$$

The ‘*Repeating Average*’ option applies the transfer function above to the measured input data, where N is value of the “**Filter Constant**” setpoint. At every reading of the input value, the value is added to the sum. At every Nth read, the sum is divided by N, and the result is new CAN message data. The sum is set to zero for the next read and summing is started again.

1.4. Output Function Blocks

In addition to the Motor Control output, the controller has two proportional current outputs. The proportional current outputs are capable of driving currents up to 2A.



NOTE: The **Proportional Output #1** has E-STOP functionality built-in. To enable the output drive, the STO input 1 (Din #3) needs to be pulled low. Due to internal isolation, the pull-down needs to be done using **GNDB/Power GND** (Pin 11, see Table 24)
Otherwise the Proportional Output #1 will remain disabled by hardware.

“**Output Type**” setpoint determines what kind of signal the output produces. Changing this setpoint causes other setpoints in the group to update to match selected type, thus the “**Output Type**” should be selected before configuring other setpoints within the setpoint group. “**Output Type**” setpoint options are listed in Table 9.

0	<i>Disabled</i>
1	<i>Proportional Current (0-2.5A)</i>
2	<i>Digital Hotshot (0-2.5A)</i>
3	<i>PWM Duty Cycle (0-100%)</i>
4	<i>Proportional Voltage (0-Vps)</i>
5	<i>Digital On/off (0-Vps)</i>

Table 9 – Output Type Options for Proportional Output

‘*Proportional Current*’ type has associated with it two setpoints not used by other types, which are the “**Dither Frequency**” and “**Dither Amplitude**” values. The output is controlled by high frequency signal (25kHz), with the low frequency dither superimposed on top. Both outputs run on same dither frequency, thus changing it to one output does change it for other outputs as well. The dither frequency will match exactly what is programmed into the setpoint, but the exact amplitude of the dither will depend on the properties of the load coil. When adjusting the dither amplitude value, select one that is high enough to ensure an immediate response to the coil to small changes in the control inputs, but not so large as to affect the accuracy or stability of the output. Refer to the coil’s datasheet for more information.

The ‘*Proportional Voltage*’ uses the measured value of the power supply and adjusts the duty cycle of the output such that the average value will match the target output voltage. If the output is running at a high frequency (for example 25kHz), the voltage can be easily averaged using a simple low pass filter.

The ‘*PWM Duty Cycle*’ option allows the user to run the output at fixed frequency configure with “**PWM Output Frequency**” setpoint, while the duty cycle changes depending on the control signal. Both outputs run on same output frequency, thus changing the frequency for one output changes frequency of the others as well. “**PWM Output Frequency**” is editable only if neither of the outputs is set to ‘*Proportional Current*’ or ‘*Hotshot Digital*’ type. Configuring output to ‘*Proportional Current*’ or ‘*Hotshot Digital*’ type changes frequency automatically to 25kHz.

Instead of proportional output control, there are also two types of digital responses possible as well. With the ‘*Digital On/Off*’ type, should the control require the output to be on, it will be turned on at whatever the system power supply is. The output will source whatever current is required by the load, up to 2.5A.

If a digital “**Output Type**” has been selected the “**Digital Response**” setpoint will be enabled as shown in Table 10.

0	<i>Normal On/Off</i>
1	<i>Inverse Logic</i>
2	<i>Latched Logic</i>
3	<i>Blinking Logic</i>

Table 10 – Digital Response Options

In a *Normal* response, when the Control input commands the output ON, then the output will be turned ON. However, in an *Inverse* response, the output will be ON unless the input commands the output ON, in which case it turns OFF.

If a *Latched* response is selected, when the input commands the state from OFF to ON, the output will change state.

If a *Blinking* response is selected, then while the input commands the output ON, it will blink at the rate in the **“Digital Blink Rate”** setpoint. When commanded OFF, the output will stay off. A blinking response is only available with a *Digital On/Off* type of output (not a Hotshot type.)

The *Hotshot Digital* type is different from in simple *Digital On/Off* in that it still controls the current through the load. This type of output is used to turn on a coil then reduce the current so that the valve will remain open, as shown in Figure 2. Since less energy is used to keep the output engaged, this type of response is very useful to improve overall system efficiency. With this output type there are associated three setpoints: **“Hold Current”**, **“Hotshot Current”** and **“Hotshot Time”** which are used to configure form of the output signal as shown in Figure 2.

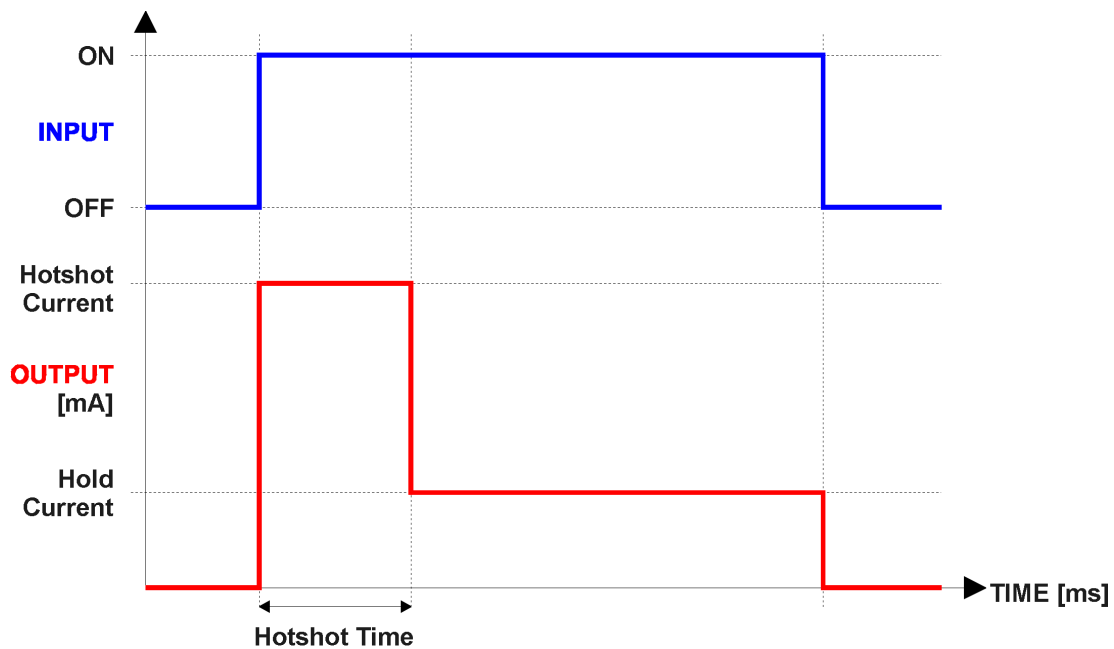

Figure 2 – Hotshot Digital Profile

For Proportional outputs signal minimum and maximum values are configured with **“Output At Minimum Command”** and **“Output At Maximum Command”** setpoints. Value range for both of the setpoints is limited by selected **“Output Type”**.

Regardless of what type of control input is selected, the output will always respond in a linear fashion to changes in the input per Equation 3.

$$y = mx + a$$

$$m = \frac{Y_{max} - Y_{min}}{X_{max} - X_{min}}$$

$$a = Y_{min} - m * X_{min}$$

Equation 3 - Linear Slope Calculations

In the case of the Output Control Logic function block, X and Y are defined as

Xmin = Control Input Minimum Ymin = **“Output at Minimum Command”**

Xmax = Control Input Maximum Ymax = **“Output at Maximum Command”**

In all cases, while X-axis has the constraint that Xmin < Xmax, there is no such limitation on the Y-axis. Thus configuring **“Output At Minimum Command”** to be greater than **“Output At Maximum Command”** allows output to follow control signal inversely.

In order to prevent abrupt changes at the output due to sudden changes in the command input, the user can choose to use the independent up or down ramps to smooth out the coil’s response. The **“Ramp Up”** and **“Ramp Down”** setpoints are in milliseconds, and the step size of the output change will be determined by taking the absolute value of the output range and dividing it by the ramp time.

The **“Control Source”** setpoint together with **“Control Number”** setpoint determine which signal is used to drive the output. For example, setting **“Control Source”** to *‘Universal Input Measured’* and **“Control Number”** to *‘1’*, connects signal measured from Universal Input1 to the output in question. The input signal is scaled per input type range between 0 and 1 to form control signal. Outputs respond in a linear fashion to changes in control signal. If a non-digital signal is selected to drive digital output the command state will be 0 (OFF) at or below the **“Output At Minimum Command”**, 1 (ON) at or above **“Output At Maximum Command”** and will not change in between those points.

In addition to the Control input, Proportional Outputs also support Enable and Override inputs.

The **“Enable Source”** setpoint together with **“Enable Number”** setpoint determine the enable signal for the output in question. The **“Enable Response”** setpoint is used to select how output will respond to the selected Enable signal. **“Enable Response”** setpoint options are listed in Table 11. If a non-digital signal is selected as Enable signal the signal is interpreted as shown in Figure 4.

0	<i>Enable When On, Else Shutoff</i>
1	<i>Enable When On, Else Rampoff</i>
2	<i>Enable When Off, Else Shutoff</i>
3	<i>Enable When Off, Else Rampoff</i>
4	<i>Enable When On, Else Ramp To Min</i>
5	<i>Enable When On, Else Ramp To Max</i>

Table 11 – Enable Response Options

Override input allows the output drive to be configured to go to a default value in the case of the override input being engaged/disengaged, depending on the logic selected in “**Override Response**”, presented on Table 12. When active, the output will be driven to the value in “**Output at Override Command**” regardless of the value of the Control input. The “**Override Source**” and “**Override Number**” together determine the Override input signal.

0	<i>Override When On</i>
1	<i>Override When Off</i>

Table 12 – Override Response Options

If a fault is detected in any of the active inputs (Control/Enable/Override) the output will respond per “**Control Fault Response**” setpoint as outlined in Table 13. Fault Value is defined by “**Output in Fault Mode**” setpoint value, which is interpreted in selected output units.

0	<i>Shutoff Output</i>
1	<i>Apply Fault Value</i>
2	<i>Hold Last Value</i>

Table 13 – Fault Response Options

Fault detection is available for current output types. A current feedback signal is measured and compared to desired output current value. Fault detection and associated setpoints are presented in section 1.5.

The outputs are inherently protected against a short to GND or +Vps by circuitry. In case of a dead short, the hardware will automatically disable the output drive, regardless of what the processor is commanding for the output. When this happens, the processor detects output hardware shutdown and commands off the output in question. It will continue to drive non-shortened outputs normally and periodically (every 5 seconds) try to re-engage the short load, if still commanded to do so. If the fault has gone away since the last time the output was engaged while shorted, the controller will automatically resume normal operation.

In the case of an open circuit, there will be no interruption of the control for any of the outputs. The processor will continue to attempt to drive the open load.

The measured current through the load is available to be broadcasted on a CAN message if desired. It is also used as the input to the diagnostic function block for each output, and an open or shorted output can be broadcasted in a DM1 message on the CAN network.

1.5. Diagnostic Function Blocks

The 40A DC Motor Controller supports diagnostic messaging. DM1 message is a message, containing Active Diagnostic Trouble Codes (DTC) that is sent to the J1939 network in case a fault has been detected. A Diagnostic Trouble Code is defined by the J1939 standard as a four-byte value.

In addition to supporting the DM1 message, the following are supported:

SPN	Suspect Parameter Number	(user defined)
FMI	Failure Mode Identifier	(see Table 15 and Table 16)
CM	Conversion Method	(always set to 0)
OC	Occurrence Count	(number of times the fault has happened)

DM2	Previously Active Diagnostic Trouble Codes	Sent only on request
DM3	Diagnostic Data Clear/Reset of Previously Active DTCs	Done only on request
DM11	Diagnostic Data Clear/Reset for Active DTCs	Done only on request

Fault detection and reaction is a standalone functionality that can be configured to monitor and report diagnostics of various controller parameters. The 40A DC Motor Controller supports 8 Diagnostics Definitions, each freely configurable by the user.

By default, the monitoring of operating voltage, CPU temperature and receive message timeouts is configured to diagnostics blocks 1, 2 and 3., In case any of these three diagnostics blocks are needed for some other use, the default settings can be adjusted by the user to suit the application.

There are 4 fault types that can be used, “**Minimum and maximum error**”, “**Absolute value error**”, “**State error**” and “**Double minimum and maximum error**”.

Minimum and maximum error has two thresholds, “MIN Shutdown” and “MAX Shutdown” that have configurable, independent diagnostics parameters (SPN, FMI, Generate DTCs, delay before flagging status). In case the parameter to monitor stays between these two thresholds, the diagnostic is not flagged.

Absolute value error has one configurable threshold with configurable parameters. In case the parameter to monitor stays below this threshold, the diagnostic is not flagged.

State error is similar to the Absolute value error, the only difference is that State error does not allow the user to specify specific threshold values; thresholds ‘1’ and ‘0’ are used instead. This is ideal for monitoring state information, such as received message timeouts.

Double minimum and maximum error lets user to specify four thresholds, each with independent diagnostic parameters. The diagnostic status and threshold values is determined and expected as show in Figure 3 below.

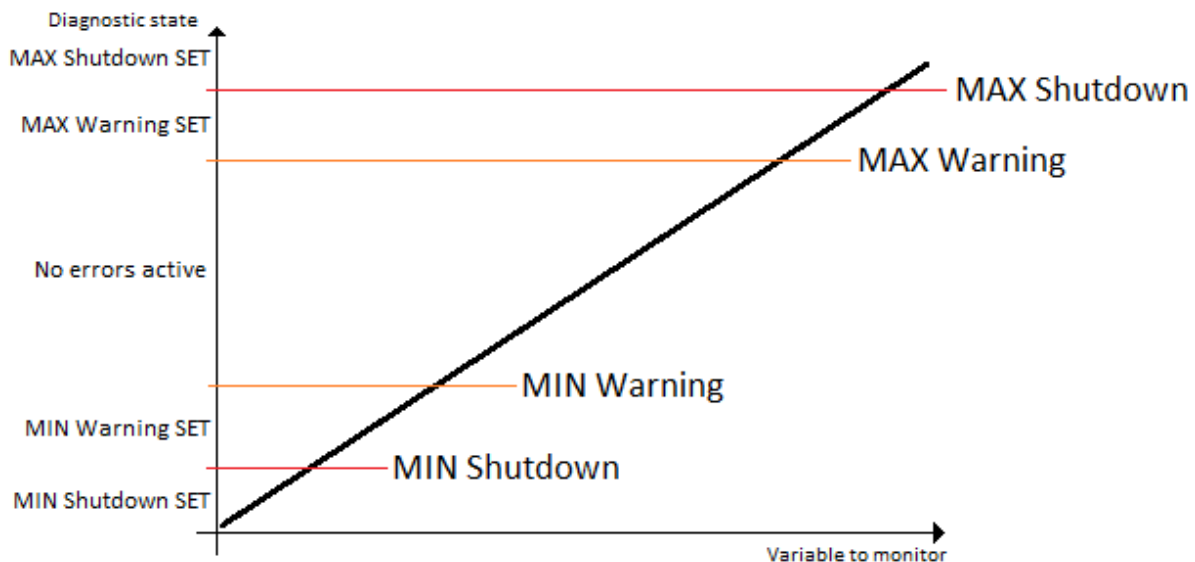

Figure 3 – Double Minimum and Maximum Error Thresholds

In case any of the Diagnostics blocks is configured to monitor Output Current Feedback, there is an internal error status flag maintained automatically for that particular output. This internal flag can be used for driving the output to a specified state in case of diagnostic event using Proportional Current Output setpoints “Control Fault Response”, “Output in Fault Mode” and “Fault Detection Enabled”.

There is also built-in error status flags for power supply and CPU temperature monitoring. In case any of the diagnostics blocks is measuring these two parameters, the corresponding internal error status flags can be used for shutting down the unit in case of failure. The setpoints “**Power Fault Disables Outputs**” and “**Over Temperature Shutdown**” can be used for enabling the shutdown of the unit (shutdown == output driving is turned off).

While there are no active DTCs, the 40A DC Motor Controller will send “No Active Faults” message. If a previously inactive DTC becomes active, a DM1 will be sent immediately to reflect this. As soon as the last active DTC goes inactive, a DM1 indicating that there are no more active DTCs will be sent.

If there is more than one active DTC at any given time, the regular DM1 message will be sent using a multipacket message to the Requester Address using the Transport Protocol (TP).



At power up, the DM1 message will not be broadcasted until after 5 second delay. This is done to prevent any power up or initialization conditions from being flagged as an active error on the network.

When the fault is linked to a DTC, a non-volatile log of the occurrence count (OC) is kept. As soon as the controller detects a new (previously inactive) fault, it will start decrementing the “**Delay before Event is flagged**” timer for that Diagnostic function block. If the fault has remained present during the delay time, then the controller will set the DTC to active, and will increment the OC in the log. A DM1 will immediately be generated that includes the new DTC. The timer is provided so that intermittent faults do not overwhelm the network as the fault comes and goes, since a DM1 message would be sent every time the fault shows up or goes away.

By default, the fault flag is cleared when error condition that has caused it goes away. The DTC is made Previously Active and is it is no longer included in the DM1 message. To identify a fault having happened, even if the condition that has caused is one away, the “**Event Cleared only by DM11**” setpoint can be set to ‘*True*’. This configuration enables DTC to stay Active, even after the fault flag has been cleared, and be included in DM1 message until a Diagnostic Data Clear/Reset for Active DTCs (DM11) has been requested.

As defined by J1939 Standard the first byte of the DM1 message reflects the Lamp status. “**Lamp Set by Event**” setpoint determines the lamp type set in this byte of DTC. “**Lamp Set by Event**” setpoint options are listed in Table 14. By default, the ‘*Amber, Warning*’ lamp is typically the one set be any active fault.

0	<i>Protect</i>
1	<i>Amber Warning</i>
2	<i>Red Stop</i>
3	<i>Malfunction</i>

Table 14 – Lamp Set by Event in DM1 Options

“**SPN for Event**” defines suspect parameter number used as part of DTC. The default value zero is not allowed by the standard, thus no DM will be sent unless “**SPN for Event**” in is configured to be different from zero. **It is user’s responsibility to select SPN that will not violate J1939 standard.** When the “**SPN for Event**” is changed, the OC of the associated error log is automatically reset to zero.

0	<i>Data Valid But Above Normal Operational Range - Most Severe Level</i>
1	<i>Data Valid But Below Normal Operational Range - Most Severe Level</i>
2	<i>Data Intermittent</i>
3	<i>Voltage Above Normal, Or Shorted To High Source</i>
4	<i>Voltage Below Normal, Or Shorted To Low Source</i>
5	<i>Current Below Normal Or Open Circuit</i>
6	<i>Current Above Normal Or Grounded Circuit</i>
7	<i>Mechanical Error</i>
8	<i>Abnormal Frequency Or Pulse Width Or Period</i>
9	<i>Abnormal Update Rate</i>
10	<i>Abnormal Rate Of Change</i>
11	<i>Root Cause Not Known</i>
12	<i>Bad Component</i>
13	<i>Out Of Calibration</i>
14	<i>Special Instructions</i>
15	<i>Data Valid But Above Normal Operating Range – Least Severe Level</i>
16	<i>Data Valid But Above Normal Operating Range – Moderately Severe Level</i>
17	<i>Data Valid But Below Normal Operating Range – Least Severe Level</i>
18	<i>Data Valid But Below Normal Operating Range – Moderately Severe Level</i>
19	<i>Network Error</i>
20	<i>Data Drifted High</i>
21	<i>Data Drifted Low</i>
31	<i>Condition Exists</i>

Table 15 – FMI for Event Options

Every fault has associated a default FMI with them. The used FMI can be configured with “**FMI for Event**” setpoint, presented in Table 15. When an FMI is selected from Low Fault FMIs in Table 16 for a fault that can be flagged either high or low occurrence, it is recommended that the user would select the high occurrence FMI from the right column of Table 16. There is no automatic setting of High and Low FMIs in the firmware, the user can configure these freely.

Low Fault FMIs	High Fault FMIs
<i>FMI=1, Data Valid But Below Normal Operation Range – Most Severe Level</i>	<i>FMI=0, Data Valid But Above Normal Operational Range – Most Severe Level</i>
<i>FMI=4, Voltage Below Normal, Or Shorted to Low Source</i>	<i>FMI=3, Voltage Above Normal, Or Shorted To High Source</i>
<i>FMI=5, Current Below Normal Or Open Circuit</i>	<i>FMI=6, Current Above Normal Or Grounded Circuit</i>
<i>FMI=17, Data Valid But Below Normal Operating Range – Least Severe Level</i>	<i>FMI=15, Data Valid But Above Normal Operating Range – Least Severe Level</i>
<i>FMI=18, Data Valid But Below Normal Operating Level – Moderately Severe Level</i>	<i>FMI=16, Data Valid But Above Normal Operating Range – Moderately Severe Level</i>
<i>FMI=21, Data Drifted Low</i>	<i>FMI=20, Data Drifted High</i>

Table 16 – Low Fault FMIs and corresponding High Fault FMIs

1.6. PID Control Function Block

The PID Control function block is an independent logic block, but it is normally intended to be associated with proportional output control blocks described earlier. When the “**Control Source**” for an output has been setup as a ‘*PID Function Block*’, the command from the selected PID block drives the physical output on the 40A DC Motor Controller.

The “**PID Target Command Source**” and “**PID Target Command Number**” setpoints determine control input and the “**PID Feedback Input Source**” and “**PID Feedback Input Number**” setpoints determine the established the feedback signal to the PID function block. The “**PID Response Profile**” will use the selected inputs as per the options listed in Table 17. When active, the PID algorithm will be called every “**PID Loop Update Rate**” in milliseconds.

0	<i>Single Output</i>
1	<i>Dual Output</i>
2	<i>Setpoint Control</i>
3	<i>On When Over Target</i>
4	<i>On When Below Target</i>

Table 17 – PID Response Options

When a ‘*Single Output*’ response is selected, the Target and Feedback inputs do not have to share the same units. In both cases, the signals are converted to a percentage values based on the minimum and maximum values associated with the source function block.

For example, a CAN command could be used to set the target value, in which case it would be converted to a percentage value using “**Receive Data Min**” and “**Receive Data Max**” setpoints in the appropriate ‘*CAN Receive X*’ function block. The closed-loop feedback signal (i.e. a 0-5V input) could be connected to ‘*Universal Input 1*’ and selected as the feedback source. In this case the value of the input would be converted to a percentage based on the “**Minimum Range**” and “**Maximum Range**” setpoints in the input block. The output of the PID function would depend on the difference between the commanded target and the measured feedback as a percentage of each signals range. In this mode, the output of the block would be a value from 0% to 100%.

In order to have the block output in range -100% to 100%, the ‘*Dual Output*’ response needs to be selected. Other than the output range, the ‘*Dual Output*’ mode is equivalent to the ‘*Single Output*’ mode.

When a ‘*Setpoint Control*’ response is selected, the “**PID Target Command Source**” automatically gets updated to ‘*Control Constant Data*’ and cannot be changed. The value set in the associated constant in the Constant Data List function block becomes the desired target value. In this case, both the target and the feedback values are assumed to be in same units and range. The minimum and maximum values for the feedback automatically become the constraints on the constant target. In this mode, the output of the block would be a value from 0% to 100%.

For example, if the feedback was setup as a 4-20mA input, a “**Constant Value X**” setpoint set to 14.2 would automatically be converted to 63.75%. The PID function would adjust the output as needed to have the measured feedback to maintain that target value.

The last two response options, ‘*On When Over Target*’ and ‘*On When Under Target*’, are designed to allow the user to combine the two proportional outputs as a push-pull drive for a system. Both

outputs must be setup to use the same control input (linear response) and feedback signal in order to get the expected output response. In this mode, the output would be between 0% to 100%.

In Order to allow the output to stabilize, the user can select a non-zero value for “**PID Delta Tolerance**”. If the absolute value of $Error_k$ is less than this value, $Error_k$ in the formula below will be set to zero.

The PID algorithm used is shown below, where G , K_i , T_i , K_d , T_d and $Loop_Update_Rate$ are configurable parameters.

$$PIDOutput_k = P_k + I_k + D_k$$

$$P_k = P_Gain * Error_k$$

$$I_k = I_Gain * ErrorSum_k$$

$$D_k = D_Gain * (Error_k - Error_{k-1})$$

$$Error_k = Target - Feedback$$

$$ErrorSum_k = ErrorSum_{k-1} + Error_k$$

$$P_{Gain} = G$$

$$I_{Gain} = K_i * T_i / T$$

$$D_{Gain} = K_d * T_d / T$$

$$T = Loop_Update_Rate * 0.001$$

Equation 4 - PID Control Algorithm

Each system will have to be turned for the optimum output response. Response times, overshoots and other variables will have to be decided by the customer using an appropriate PID tuning strategy. Axiomatic is not responsible for tuning the control system.

1.7. Lookup Table Function Block

Lookup Tables are used to give output response up to 10 slopes per input. If more than 10 slopes are required, A Programmable Logic Block can be used to combine up to three tables to get 30 slopes as described in Section 1.8.

Lookup tables have two differing modes defined by “**X-Axis Type**” setpoint, given in Table 18. Option ‘0 – Data Response’ is the normal mode where block input signal is selected with the “**X-Axis Source**” and “**X-Axis Number**” setpoints and X values present directly input signal values. With option ‘1 – Time Response’ the input signal is time and X values present time in milliseconds. And selected input signal is used as digital enable.

0	Data Response
1	Time Response

Table 18 – X-Axis Type Options

The slopes are defined with (x, y) points and associated point response. X value presents input signal value and Y value corresponding Lookup Table output value. “PointN – Response” setpoint defines type of the slope from preceding point to the point in question. Response options are given in Table 19. ‘Ramp To’ gives a linearized slope between points, whereas ‘Jump to’ gives a point to point response, where any input value between X_{N-1} and X_N will result Lookup Table output being Y_N . “Point0 – Response” is always ‘Jump To’ and cannot be edited. Choosing ‘Ignored’ response causes associated point and all the following points to be ignored.

0	<i>Ignore</i>
1	<i>Ramp To</i>
2	<i>Jump To</i>

Table 19 – PointN – Response Options

In case Time Response is used, the “**Autocycle**” setpoint can be used for generating a repeating, cyclic output while the selected control source enables the time response output of the particular lookup table.

The X values are limited by minimum and maximum range of the selected input source if the source is one of the Input Blocks or a Math Function Block. For the fore mentioned sources X-Axis data will be redefined when ranges are changed, therefore inputs should be adjusted before changing X-Axis values. For other sources Xmin and Xmax are 0 and 1000. The X-Axis is constraint to be in rising order, thus value of the next index is greater than or equal to preceding one. Therefore, when adjusting the X-Axis data, it is recommended that X_{10} is changed first, then lower indexes in descending order.

$$Xmin \leq X_0 \leq X_1 \leq X_2 \leq X_3 \leq X_4 \leq X_5 \leq X_6 \leq X_7 \leq X_8 \leq X_9 \leq X_{10} \leq Xmax$$

The Y-Axis has no constraints on the data it presents, thus inverse, decreasing, increasing or other response can be easily established. The Smallest of the Y-Axis values is used as Lookup Table output min and the largest of the Y-Axis values is used as Lookup Table output max (i.e. used as Xmin and Xmax values in linear calculation, Section 1.4). Ignored points are not considered for min and max values.

1.8. Programmable Logic Function Block

The Programmable Logic Function Block is very powerful tool. A Programmable Logic can be linked to up to three Lookup Tables, any of which would be selected only under given conditions. Thus, output of a Programmable Logic at any given time will be the output of the Lookup Table selected by defined logic. Therefore, up to three different responses to the same input, or three different responses to different inputs, can become the input to another function block.

In order to enable any one of the Programmable Logic blocks, the “**Programmable Logic Enabled**” setpoint must be set to ‘*True*’. By default, all Logic blocks are disabled.

The three associated tables are selected by setting “**Table X – Lookup Table Block Number**” setpoint to desired Lookup Table number, for example selecting 1 would set Lookup Table 1 as TableX.

For each TableX there are three conditions that define the logic to select the associated Lookup Table as Logic output. Each condition implements function *Argument1 Operator Argument2* where Operator is logical operator defined by setpoint “**Table X – Condition Y, Operator**”. Setpoint options are listed in Table 20. Condition arguments are selected with “**Table x – Condition Y, Argument Z Source**” and “**Table x – Condition Y, Argument Z Number**” setpoints. If ‘0 – Control not Used’ option is selected as “**Table x – Condition Y, Argument Z Source**” the argument is interpreted as 0.

0	<i>=, Equal</i>
1	<i>!=, Not Equal</i>
2	<i>>, Greater Than</i>
3	<i>>=, Greater Than or Equal</i>
4	<i><, Less Than</i>
5	<i><=, Less Than or Equal</i>

Table 20 – Table X – Condition Y, Operator Options

The three conditions are evaluated and if the result satisfies logical operation defined with “**Table X – Conditions Logical Operator**” setpoint, given in Table 21, the associated Lookup Table is selected as output of the Logical block. Option ‘0 – Default Table’ selects associated Lookup Table in all conditions.

0	<i>Default Table (Table1)</i>
1	<i>Cnd1 And Cnd2 And Cnd3</i>
2	<i>Cnd1 Or Cnd2 Or Cnd3</i>
3	<i>(Cnd1 And Cnd2) Or Cnd3</i>
4	<i>(Cnd1 Or Cnd2) And Cnd3</i>

Table 21 – Table X – Conditions Logical Operator Options

The three logical operations are evaluated in order and the first to satisfy gets selected, thus if Table1 logical operation is satisfied, the Lookup Table associated with Table1 gets selected regardless of two other logical operations. In addition, if none of the logical operations is satisfied the Lookup Table associated with Table1 gets selected.

1.9. Math Function Block

There are six mathematical function blocks (two full versions and four simplified ones) that allow the user to define basic algorithms. A math function block can take up to five input signals. Each input is then scaled according to the associated limit and scaling setpoints.

The mathematical block’s input signal value can have values in range -1000 to 1000. In case the signal value is larger than that, the “**Function X Input Y Minimum**” and “**Function X Input Y Maximum**” values can be used to rescale the value. For additional control the user can also adjust the “**Function X Input Y Scaler**”. By default, each input has a scaling ‘weight’ of 1.0 However, each input can be scaled from -1.0 to 1.0 as necessary before it is applied in the function.

A mathematical function block includes four selectable functions, which each implements equation $A \text{ operator } B$, where A and B are function inputs and operator is function selected with setpoint “**Math function X Operator**”. Setpoint options are presented in Table 22. The functions are connected so that result of the preceding function goes into Input A of the next function. Thus Function 1 has both

Input A and Input B selectable with setpoints, where Functions 2 to 4 have only Input B selectable. Input is selected by setting “**Function X Input Y Source**” and “**Function X Input Y Number**”. If “**Function X Input B Source**” is set to 0 ‘Control not used’ signal goes through function unchanged.

$$\text{Math Block Output} = (((A1 \text{ op1 } B1) \text{ op2 } B2) \text{ op3 } B3) \text{ op4 } B4$$

0	=, True when InA equals InB
1	!=, True when InA not equal InB
2	>, True when InA greater than InB
3	>=, True when InA greater than or equal InB
4	<, True when InA less than InB
5	<=, True when InA less than or equal InB
6	OR, True when InA or InB is True
7	AND, True when InA and InB are True
8	XOR, True when either InA or InB is True, but not both
9	+, Result = InA plus InB
10	-, Result = InA minus InB
11	x, Result = InA times InB
12	/, Result = InA divided by InB
13	MIN, Result = Smallest of InA and InB
14	MAX, Result = Largest of InA and InB
15	MAX-MIN, Result = Absolute value of (InA – InB)

Table 22 – Math function X Operator Options

For logic operations (6, 7, 8) scaled input greater or equal to 1 is treated as TRUE. For logic operations (0 to 8), the result of the function will always be 0 (FALSE) or 1 (TRUE). For the arithmetic functions (9 to 14), it is recommended to scale the data such that the resulting operation will not exceed full scale (-1e6 to 1e6) and saturate the output result.

When dividing, a zero divider will always result in a full (1e6) output value for the associated function.

Lastly the resulting mathematical calculation, presented as real value, can be scaled into the appropriate physical units using the “**Math Output Minimum Range**” and “**Math Output Maximum Range**” setpoints. These values are also used as the limits when the Math Function I selected as the input source for another function block.

1.10. Control Variable Data Blocks

In case run time settable, non-volatile data is required in the control algorithm, the Control Variable Data Blocks offer one possible solution. These function blocks contain a single variable with rules for updating the value at run time, without the need for the user to trigger the variable update process as it is done with the Control Constant Data Blocks.

The “**Variable Value**” setpoint shows the current value for the variable. This setpoint is user configurable, so it is possible to modify the value using EA.

“**Variable Value Data Source**” and “**Variable Data Data Number**” define the source from which the new Variable Data value is read at update event.

The variable data update process is controlled using the next five setpoints, namely “**Variable Value Update Trigger Source**”, “**Variable Value Update Trigger Number**”, “**Variable Value Update Trigger Threshold Source**”, “**Variable Value Update Trigger Threshold Number**” and “**Variable Value Update Function**”. The trigger number and source define the control signal to be compared with the trigger threshold control signal. The comparison is done using the logical (or mathematical) operator that can be selected using “**Variable Value Update Function**” setpoint.

In case the logical operation evaluates as *True* (for the Math functions, greater than zero) the variable data value is updated from the selected data source and the new value is stored into Flash memory. The save is done only once per evaluating the update function as *True*. Before the next save can happen, the update function must evaluate as *False* (for the Math functions, equal to zero) at least once. Also, the minimum time between two variable data saving events is set to 10 seconds (not user configurable limit).

1.11. DTC React

The DTC React function block is a very simple function which will allow a received DTC, sent from another ECU on a DM1 message, to disable an output or be used as input to another type of logic block. Up to five SPN/FMI combinations can be selected.

Should a DM1 message be received with the SPN/FMI combination defined, the corresponding DTC State will be set to ON. Once ON, if the same SPN/FMI combination has not been received again after 3 seconds, the DTC State will be reset to OFF.

The DTC could be used as a digital (on/off) input for any function block as appropriate.

1.12. CAN Transmit Message Function Block

The CAN Transmit function block is used to send any output from another function block (i.e. input, CAN receive) to the J1939 network. The AX102100 ECU has six CAN Transmit Messages and each message has four completely user defined signals.

1.12.1. CAN Transmit Message Setpoints

Each CAN Transmit Message setpoint group includes setpoints that effect the whole message and are thus mutual for all signals of the message. These setpoints are presented in this section. The setpoints that configure an individual signal are presented in next section.

The “**Transmit PGN**” setpoint sets PGN used with the message. **User should be familiar with the SAE J1939 standard and select values for PGN/SPN combinations as appropriate from section J1939/71.**

“**Repetition Rate**” setpoint defines the interval used to send the message to the J1939 network. If the “**Repetition Rate**” is set to zero, the message is disabled unless it shares its PGN with another message. In case of a shared PGN repetition rate of the LOWEST numbered message are used to send the message ‘bundle’.



At power up, transmitted message will not be broadcasted until after a 5 second delay. This is done to prevent any power up or initialization conditions from creating problems on the network.

By default, all messages are sent on Proprietary B PGNs as broadcast messages. Thus “**Transmit Message Priority**” is always initialized to 6 (low priority) and the “**Destination Address**” setpoint is not used. This setpoint is only valid when a PDU1 PGN has been selected, and it can be set either to the Global Address (0xFF) for broadcasts or sent to a specific address as setup by the user.

1.12.2. CAN Transmit Signal Setpoints

Each CAN transmit message has four associated signals, which define data inside the Transmit message. “**Control Source**” setpoint together with “**Control Number**” setpoint define the signal source of the message. “**Control Source**” and “**Control Number**” options are listed in Table 23. Setting “**Control Source**” to ‘*Control Not Used*’ disables the signal.

“**Transmit Data Size**” setpoint determines how many bits signal reserves from the message. “**Transmit Data Index in Array**” determines in which of 8 bytes of the CAN message LSB of the signal is located. Similarly, “**Transmit Bit Index in Byte**” determines in which of 8 bits of a byte the LSB is located. These setpoints are freely configurable, thus **it is the User’s responsibility to ensure that signals do not overlap and mask each other.**

“**Transmit Data Resolution**” setpoint determines the scaling done on the signal data before it is sent to the bus. “**Transmit Data Offset**” setpoint determines the value that is subtracted from the signal data before it is scaled. Offset and Resolution are interpreted in units of the selected source signal.

1.13. CAN Receive Function Block

The CAN Receive function block is designed to take any SPN from the J1939 network, and use it as an input to another function block (i.e. Outputs).

The “**Receive Message Enabled**” is the most important setpoint associated with this function block and it should be selected first. Changing it will result in other setpoints being enabled/disabled as appropriate. By default, ALL receive messages are disabled.

Once a message has been enabled, a Lost Communication fault will be flagged if that message is not received off the bud within the “**Receive Message Timeout**” period. This could trigger a Lost Communication event as described in section 1.5. In order to avoid timeouts on a heavily saturated network, it is recommended to set the period at least three times longer than the expected update rate. To disable the timeout feature, simply set this value to zero, in which case the received message will never trigger a Lost Communication fault.

By default, all control messages are expected to be sent to the 40A DC Motor Controller on Proprietary B PGNs. However, should a PDU1 message be selected, the 40A DC Motor Controller can be setup to receive it from any ECU by setting the “**Specific Address that sends the PGN**” to the Global Address (0xFF). If a specific address is selected instead, then any other ECU data on the PGN will be ignored.

The “**Receive Data Size**”, “**Receive Data Index in Array (LSB)**”, “**Receive Bit Index in Byte (LSB)**”, “**Receive Resolution**” and “**Receive Offset**” can all be used to map any SPN supported by the J1939 standard to the output data of the Received function block.

As mentioned earlier, a CAN receive function clock can be selected as the source of the control input for the output function blocks. When this is case, the “**Received Data Min (Off Threshold)**” and “**Received Data Max (On Threshold)**” setpoints determine the minimum and maximum values of the control signal. As the names imply, they are also used as the On/Off thresholds for digital output types. These values are in whatever units the data is AFTER the resolution and offset is applied to CAN receive signal.

The 40A DC Motor Controller I/O supports up to eight unique CAN Receive Messages.

1.14. Available Control Sources

Many of the Function Blocks have selectable input signals, which are determined with “[**Name**] **Source**” and “[**Name**] **Number**” setpoints. Together, these setpoints uniquely select how the I/O of the various function blocks are linked together. “[**Name**] **Source**” setpoint determines the type of the source and “[**Name**] **Number**” selects the actual source if there is more than one of the same type. Available “[**Name**] **Source**” options and associated “[**Name**] **Number**” ranges are listed in Table 23. All sources, except “CAN message reception timeout”, are available for all blocks, including output control blocks and CAN Transmit messages. Thought input Sources are freely selectable, not all options would make sense for any particular input and it is up to the user to program the controller in a logical and functional manner.

Sources	Number Range	Notes
<i>0: Control Not Used</i>	N/A	When this is selected, it disables all other setpoints associated with the signal in question.
<i>1: Received CAN Message</i>	1 to 8	User must enable the function block, as it is disabled by default.
<i>2: Universal Input Measured</i>	1 to 2	
<i>3: Digital Input Detected</i>	1 to 7	1-2 = DIN1-2, 3 = STO1, 4 = OC (Motor), 5-6= SC1-2 (Prop. Outputs), 7 = Combined 'Motor enable' (0x01) and 'Clear fault' (0x02) flags.
<i>4: PID Function Block</i>	1 to 2	User must enable the function block, as it is disabled by default.
<i>5: Lookup Table</i>	1 to 4	
<i>6: Programmable Logic Block</i>	1 to 2	User must enable the function block, as it is disabled by default.
<i>7: Math Function Block</i>	1 to 6	User must enable the function block, as it is disabled by default.
<i>8: Control Constant Data</i>	1 to 15	1 = FALSE, 2 = TRUE, 3 to 15 = User Selectable
<i>9: Diagnostic Trouble Code</i>	1 to 5	Will only be valid if the corresponding DTC has a non-zero SPN
<i>10: Output Target Value</i>	1 to 2	
<i>11: Output Current Feedback</i>	1 to 4	Measured Feedback current from the proportional output in mA, used in Output Diagnostics. 1-2 = Prop. Outputs, 3 = Motor Output (+), 4 = Motor Output (-)
<i>12: Power Supply Measured</i>	0 to 255	Measured power supply value in Volts. The Parameter sets the threshold in Volts to compare with. In case Parameter is set to '0', the measured value is used as is.
<i>13: Processor Temperature Measured</i>	0 to 255	Measured processor temperature in °C. The Parameter sets the threshold in Celcius to compare with. In case Parameter is set to '0', the measured value is used as is.
<i>14: CAN Reception Timeout</i>	N/A	Only available in Output blocks.
<i>15: Control Variable Data</i>	1 to 2	Variable data.

Table 23 – Available Control Sources and Numbers

If a non-digital signal is selected to drive a Universal Input in digital input mode, the signal is interpreted to be OFF at or below the minimum of selected source and ON at or above the maximum of the selected source, and it will not change in between those points. Thus, analog to digital interpretation has a built in hysteresis defined by minimum and maximum of the selected source, as shown in Figure 4. A Universal Input signal is interpreted to be ON at or above “Maximum Range” and OFF at or below “Minimum Range”.

Control Constant Data has no unit nor minimum and maximum assigned to it, thus user has to assign appropriate constant values according to intended use.

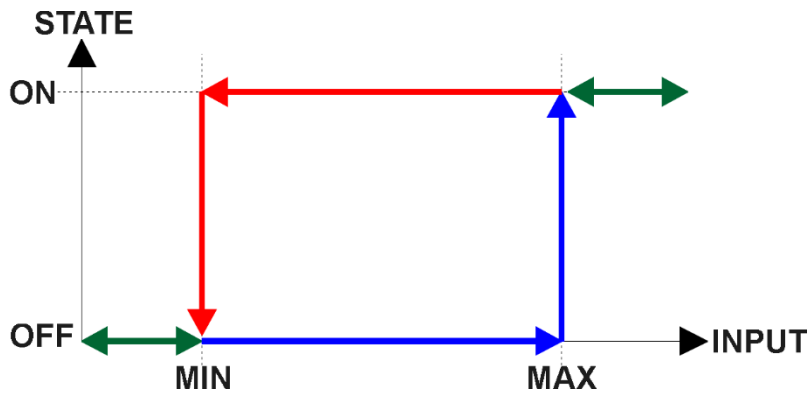

Figure 4 – Analog source to Digital input

2. Installation Instructions

2.1. Dimensions and Pinout

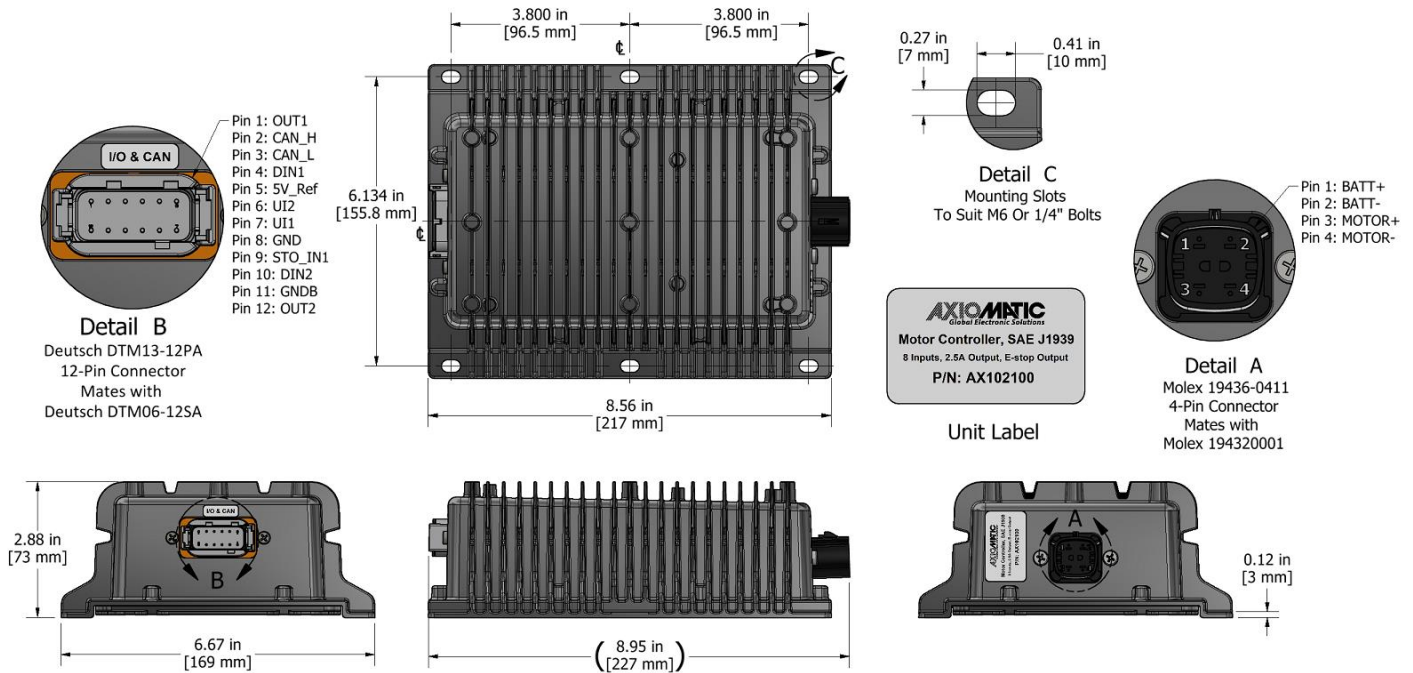

Figure 5 – AX102100 Dimensional Drawing

<u>Input, Output & CAN Connector:</u> TE Deutsch DTM13-12PA	<u>Power & Motor Connector:</u> 4 pin Molex P/N: 19436-0411
Pin 1: Universal Output 1 (Brake Output)	Pin 1: Battery +
Pin 2: CAN_H	Pin 2: Battery -
Pin 3: CAN_L	Pin 3: Motor +
Pin 4: Digital Input 1	Pin 4: Motor -
Pin 5: +5V Reference	
Pin 6: Universal Input 2	
Pin 7: Universal Input 1 (STO Power Input)	
Pin 8: Signal GND	
Pin 9: STO Input (Digital Input 3)	
Pin 10: Digital Input 2	
Pin 11: Power GND	
Pin 12: Universal Output 2	

Table 24 – AX102100 Connector Pin-Out

3. Overview Of J1939 Features

The software was designed to provide flexibility to the user with respect to messages sent from the ECU by providing:

- Configurable ECU Instance in the NAME (to allow multiple ECUs on the same network)
- Configurable Input Parameters
- Configurable PGN and Data Parameters
- Configurable Diagnostic Messaging Parameters, as required
- Diagnostic Log, maintained in non-volatile memory.

3.1. Introduction to Supported Messages

The ECU is compliant with the standard SAE J1939 and supports following PGNs from the standard.

From J1939-21 – Data Link Layer

- | | | |
|--|------------|----------|
| • Request | 59904 | 0x00EA00 |
| • Acknowledgement | 59392 | 0x00E800 |
| • Transport Protocol – Connection Management | 60416 | 0x00EC00 |
| • Transport Protocol – Data Transfer Message | 60160 | 0x00EB00 |
| • Proprietary B | from 65280 | 0x00FF00 |
| | to 65535 | 0x00FFFF |

From J1939-73 – Diagnostics

- | | | |
|--|-------|----------|
| • DM1 – Active Diagnostic Trouble Codes | 65226 | 0x00FECA |
| • DM2 – Previously Active Diagnostic Trouble Codes | 65227 | 0x00FECB |
| • DM3 – Diagnostic Data Clear/Reset for Previously Active DTCs | 65228 | 0x00FECC |
| • DM11 – Diagnostic Data Clear/Reset for Active DTCs | 65235 | 0x00FED3 |
| • DM14 – Memory Access Request | 55552 | 0x00D900 |
| • DM15 – Memory Access Response | 55296 | 0x00D800 |
| • DM16 – Binary Data Transfer | 55040 | 0x00D700 |

From J1939-81 – Network Management

- | | | |
|--------------------------------|-------|----------|
| • Address Claimed/Cannot Claim | 60928 | 0x00EE00 |
| • Commanded Address | 65240 | 0x00FED8 |

From J1939-71 – Vehicle Application Layer

- | | | |
|---------------------------|-------|----------|
| • Software Identification | 65242 | 0x00FEDA |
|---------------------------|-------|----------|

None of the application layer PGNs are supported as part of the default configurations, but they can be selected as desired for transmit function blocks.

Setpoints are accessed using standard Memory Access Protocol (MAP) with proprietary addresses. The Electronic Assistant[®] (EA) allows for quick and easy configuration of the unit over CAN network.

3.2. NAME, Address and Software ID

The 40A DC Motor Controller I/O ECU has the following default for the J1939 NAME. The user should refer to the SAE J1939/81 standard for more information on these parameters and their ranges.

Arbitrary Address Capable	Yes
Industry Group	0, Global
Vehicle System Instance	0
Vehicle System	0, Non-specific system
Function	132, Axiomatic DC Motor Controller
Function Instance	15, Axiomatic AX102100
ECU Instance	0, First Instance
Manufacture Code	162, Axiomatic Technologies
Identity Number	Variable, uniquely assigned during factory programming for each ECU

The ECU Instance is a configurable setpoint associated with the NAME. Changing this value will allow multiple ECUs of this type to be distinguishable from one another when they are connected on the same network.

The default value of the “ECU Address” setpoint is 128 (0x80), which is the preferred starting address for self-configurable ECUs as set by the SAE in J1939 tables B3 and B7. The EA will allow the selection of any address between 0 and 253. ***It is the user’s responsibility to select an address that complies with the standard.*** The user must also be aware that since the unit is arbitrary address capable, if another ECU with a higher priority NAME contends for the selected address, the 40A DC Motor Controller I/O will continue select the next highest address until it finds one that it can claim. See J1939/81 for more details about address claiming.

Software Identifier

PGN 65242		Software Identification	- SOFT
Transmission Repetition Rate:		On request	
Data Length:		Variable	
Extended Data Page:		0	
Data Page:		0	
PDU Format:		254	
PDU Specific:		218 PGN Supporting Information:	
Default Priority:		6	
Parameter Group Number:		65242 (0xFEDA)	
Start Position	Length	Parameter Name	SPN
1	1 Byte	Number of software identification fields	965
2-n	Variable	Software identification(s), Delimiter (ASCII “*”)	234

Byte 1 is set to 5, and the identification fields are as follows.

(Part Number)*(Version)*(Date)*(Owner)*(Description)

The EA shows all this information in “General ECU Information”, as shown below.

Note: The information provided in the Software ID is available for any J1939 service tool which supports the PGN -SOFT.

4. ECU Setpoints Accessed With Electronic Assistant

This section describes in detail each setpoint, and their default and ranges. Default values presented in tables are values used when setpoint in question is active. Many of the setpoints are dependent on other setpoints and they may not be active by default. Associated Figures show screen capture of initial operation, however some of the setpoints are not in default condition as they are set differently to activate more setpoints for the image. The setpoints are divided into setpoint groups as they are shown in EA. For more information on how each setpoint is used by 40A DC Motor controller, refer to the relevant section in this user manual.

4.1. J1939 Network Parameters

“ECU Instance Number” and “ECU Address” setpoints and their effect are defined in Section 3.2.

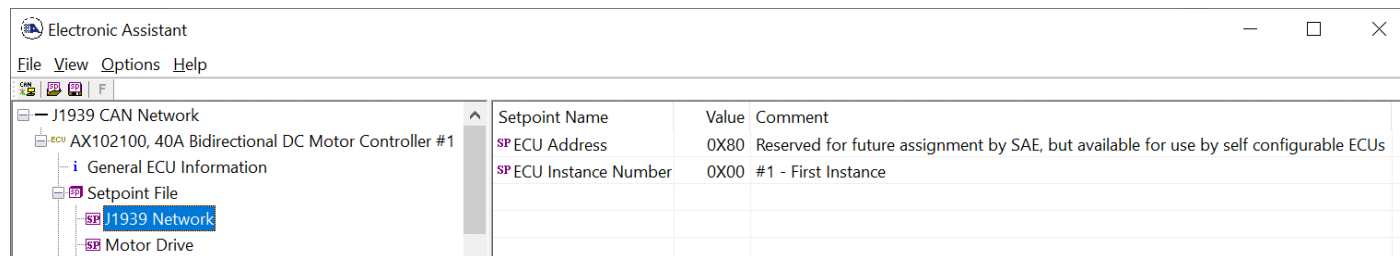

Figure 6 – Screen Capture of J1939 Setpoints

Name	Range	Default	Notes
ECU Address	0x80	0-253	Preferred address for a self-configurable ECU
ECU Instance	0-7	0x00	Per J1939-81

Table 25 – J1939 Network Setpoints

If non-default values for the “ECU Instance Number” or “ECU Address” are used, they will be mirrored during a setpoint file flashing, and will only take effect once the entire file has been downloaded to the unit. After the setpoint flashing is complete, the unit will claim the new address and/or re-claim the address with the new NAME. If these setpoints are changing, it is recommended to close and re-open the CAN connection on EA after the file is loaded so that only the new NAME and address are showing in the J1939 CAN Network ECU list.

4.2. Motor Drive Setpoints

The Motor Drive function block is explained in more detail in section 1.1

Setpoint Name	Value	Comment
SP Output At Minimum Command	-35000 mA	
SP Output At Maximum Command	35000 mA	
SP Output At Override Command	0 mA	
SP Invert Motor Direction		Parameter not used with current Control Source selected
SP Ramp Up (Min to Max)	100 ms	
SP Ramp Down (Max to Mix)	100 ms	
SP Control Source	2	Universal Input Measured
SP Control Number	1	Universal Input Measured #1
SP Direction Source	0	Control Not Used
SP Direction Number	1	Control Not Used #1
SP Enable Source	0	Control Not Used
SP Enable Number		Parameter not used with current Enable Source selected
SP Enable Response		Parameter not used with current Enable Source selected
SP Override Source	0	Control Not Used
SP Override Number		Parameter not used with current Override Source selected
SP Override Response		Parameter not used with current Override Source selected
SP Maximum driver stage temperature	125 DegC	
SP Driver Stage temperature hysteresis	20 DegC	
SP Motor current filter constant	100	
SP Stable drive values before changing direction	1	2 stable values

Figure 7 – Screen Capture of Motor Drive Setpoints

Name	Range	Default	Notes
Output At Minimum Command	-70000mA to 0mA	-35000mA	
Output At Maximum Command	0mA to 70000mA	35000mA	
Output At Override Command	-70000mA to 70000mA	0mA	
Invert Motor Direction	Drop List	False	
Ramp Up (Min to Max)	0...60000ms	100ms	
Ramp Down (Max to Min)	0...60000ms	100ms	
Control Source	Drop List	Control Not Used	See Section 1.14
Control Number	Drop List	1	See Section 1.14
Direction Source	Drop List	Control Not Used	See Section 1.14
Direction Number	Drop List	1	See Section 1.14
Enable Source	Drop List	Control Not Used	See Section 1.14
Enable Number	Drop List	1	See Section 1.14
Enable Response	Drop List	0	See Table 11
Override Source	Drop List	Control Not Used	See Section 1.14
Override Number	Drop List	1	See Section 1.14
Override Response	Drop List	0	See Table 12
Maximum driver stage temperature	0...135°C	125°C	
Driver stage temperature hysteresis	0...100°C	20°C	
Motor current filter constant	100	1...10000	
Stable drive values before changing direction	Drop List	No delay	

Table 26 – Motor Drive Setpoints

4.3. Universal Input Setpoints

The Universal Inputs are defined in section 1.2

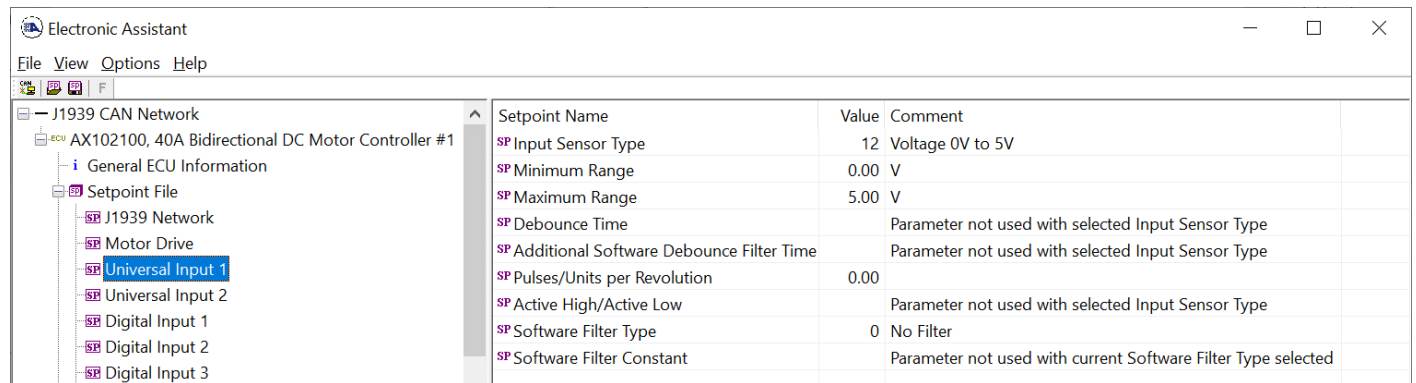

Figure 8 – Screen Capture of Universal Input Setpoints

Name	Range	Default	Notes
Input Sensor Type	Drop List	VOLTAGE_0_TO_5V	See Table 2
Minimum Range	From Minimum Error to Maximum Range	Depends on Input Sensor Type	
Maximum Range	From Minimum Range to Maximum Error	Depends on Input Sensor Type	
Debounce Time	Drop List	None	See Table 3
Additional Software Debounce Filter Time	Drop List	0ms	See Table 4
Pulses/Units per Revolution	Drop List	0	See Section 1.2
Active High/Active Low	Drop List	Active High	See Table 6
Software Filter Type	Drop List	No Filtering	See Table 8
Software Filter Constant	1..1000	1	

Table 27 – Universal Input Setpoints

4.4. Digital Input Setpoints

The Digital Inputs are defined in Section 1.2.1.

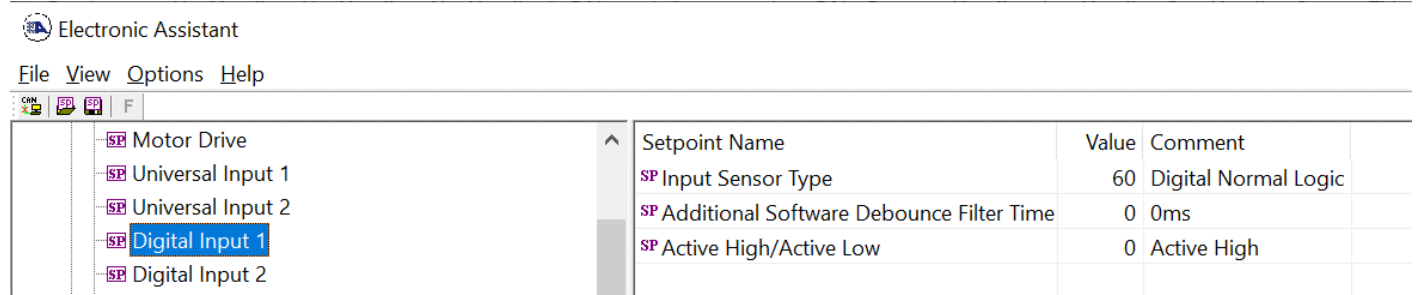

Figure 9 – Screen Capture of Digital Input Setpoints

Name	Range	Default	Notes
Input Sensor Type	Drop List	Digital Normal Logic	See Table 2
Additional Software Debounce Filter Time	Drop List	0ms	See Table 4
Active High/Active Low	Drop List	0	

Table 28 – Digital Input Setpoints

4.5. Proportional Output Drive Setpoints

The Proportional Output function block is defined in Section 1.4. Please refer there for detailed information about how these setpoints are used. Outputs are disabled by default. To enable an output “**Output Type**” and “**Control Source**” must be chosen.

Electronic Assistant

File View Options Help

J1939 CAN Network

ECU AX102100, 40A Bidirectional DC Motor Controller #1

- General ECU Information
- Setpoint File
 - J1939 Network
 - Motor Drive
 - Universal Input 1
 - Universal Input 2
 - Digital Input 1
 - Digital Input 2
 - Digital Input 3
 - Proportional Output Drive 1**
 - Proportional Output Drive 2
 - Constant Data List
 - Variable Data List 1
 - Variable Data List 2
 - PID Control 1
 - PID Control 2
 - Lookup Table 1
 - Lookup Table 2
 - Lookup Table 3
 - Lookup Table 4
 - Programmable Logic 1
 - Programmable Logic 2
 - Math Function Block 1
 - Math Function Block 2
 - Small Math Function Block 3
 - Small Math Function Block 4
 - Small Math Function Block 5

Setpoint Name	Value	Comment
SP Output Type	1	Proportional Current
SP Output At Minimum Command	0 mA	
SP Output At Maximum Command	2000 mA	
SP Output At Override Command	2 mA	
SP Dither Frequency	200 Hz	
SP Dither Amplitude	0 mA	
SP Ramp Up (Min to Max)	1000 ms	
SP Ramp Down (Max to Mix)	1000 ms	
SP PWM Output Frequency	25000 Hz, (Not configurable - Output in Current mode)	
SP Hold Current		Parameter not used with current Output Type selected
SP Hotshot Current		Parameter not used with current Output Type selected
SP Hotshot Time		Parameter not used with current Output Type selected
SP Digital Response		Parameter not used with current Output Type selected
SP Digital Override State		Parameter not used with current Output Type selected
SP Digital Blink Rate		Parameter not used with current Output Type selected
SP Control Source	2 Universal Input Measured	
SP Control Number	1 Universal Input Measured #1	
SP Enable Source	0 Control Not Used	
SP Enable Number		Parameter not used with current Enable Source selected
SP Enable Response		Parameter not used with current Enable Source selected
SP Override Source	0 Control Not Used	
SP Override Number		Parameter not used with current Override Source selected
SP Override Response		Parameter not used with current Override Source selected
SP Fault Detection is Enabled	0 False	
SP Output Fault Response		Parameter not used - Fault Detection is Disabled
SP Output in Fault Mode		Parameter not used - Fault Detection is Disabled

Figure 10 – Screen Capture of Proportional Output Setpoints

Name	Range	Default	Notes
Output Type	Drop List	Proportional Current -400mA...400mA	See Table 9
Output At Minimum Command	0 to Limit	-400mA	
Output At Maximum Command	0 to Limit	400mA	
Output At Override Command	0 to Limit	0mA	
Dither Frequency	50 to 400Hz	200Hz	
Dither Amplitude	0 to 500 mA	0	
Ramp Up (Min to Max)	0 to 10 000ms	1000ms	
Ramp Down (Max to Min)	0 to 10 000ms	1000ms	
PWM Output Frequency	1 to 25000Hz	25000Hz	
Hold Current	0 to 2500mA	0mA	
Hotshot Current	0 to 2500mA	0mA	
Hotshot Time	500 to 10000ms	500ms	
Digital Response	Drop List	Normal On/Off	
Digital Override State	Drop List	ON	
Digital Blink Rate	100 to 5000ms	1000ms	
Control Source	Drop List	Universal Input Measured	See Table 23
Control Number	Depends on control source	1	See Table 23
Enable Source	Drop List	Control not used	See Table 23
Enable Number	Depends on enable source	1	See Table 23
Enable Response	Drop List	Enable When On, else Shutoff	See Table 11
Override Source	Drop List	Control not used	See Table 23
Override Number	Depends on enable source	1	See Table 23
Override Response	Drop List	Override When On	See Table 12
Fault Detection is Enabled	Drop List	True	
Output Fault Response	Drop List	Shutoff Output	See Table 13
Output in Fault Mode	Depends on Output type	0mA	

Table 29 – Proportional Output Setpoints

4.6. Constant Data List Setpoints

The Constant Data List Function Block is provided to allow the user to select values as desired for various logic block functions.

The first two constants are fixed values of 0 (False) and 1 (True) for use in binary logic. The remaining 13 constants are fully user programmable to any value between +/- 1 000 000. The default values are arbitrary and should be configured by the user as appropriate for their application.

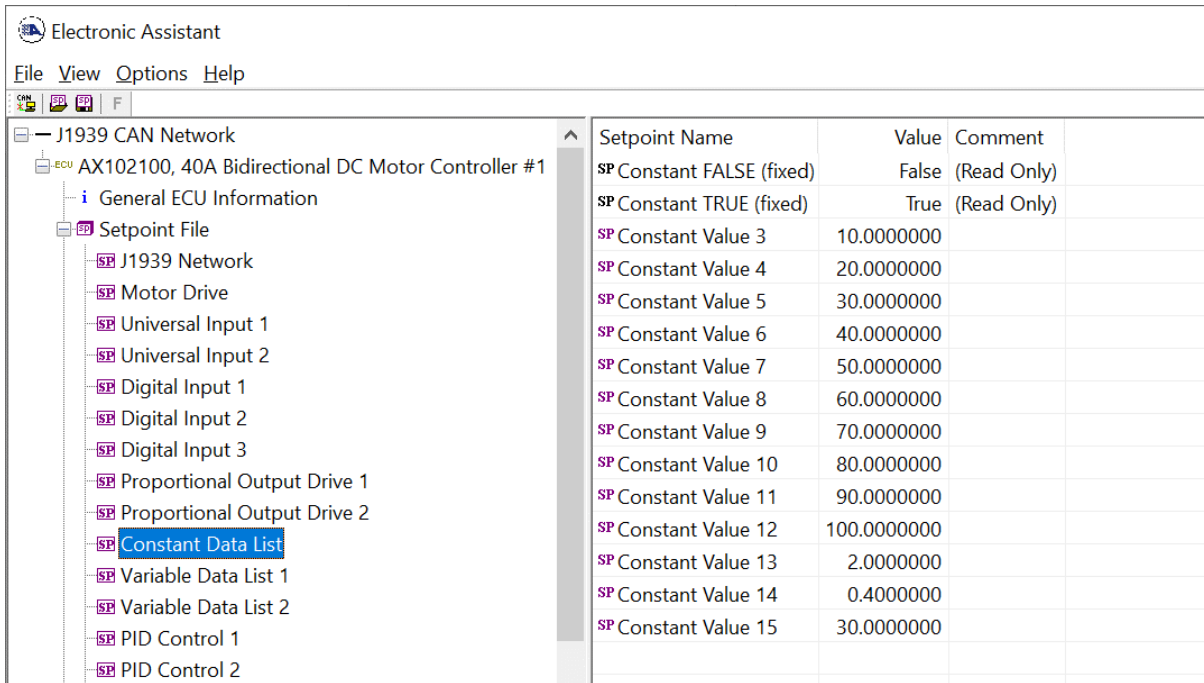

The screenshot shows the 'Electronic Assistant' software interface. On the left, a tree view displays the project structure for 'J1939 CAN Network' and 'AX102100, 40A Bidirectional DC Motor Controller #1'. The 'Constant Data List' block is selected and highlighted in blue. On the right, a table lists the setpoints with their names, values, and comments.

Setpoint Name	Value	Comment
SP Constant FALSE (fixed)	False	(Read Only)
SP Constant TRUE (fixed)	True	(Read Only)
SP Constant Value 3	10.0000000	
SP Constant Value 4	20.0000000	
SP Constant Value 5	30.0000000	
SP Constant Value 6	40.0000000	
SP Constant Value 7	50.0000000	
SP Constant Value 8	60.0000000	
SP Constant Value 9	70.0000000	
SP Constant Value 10	80.0000000	
SP Constant Value 11	90.0000000	
SP Constant Value 12	100.0000000	
SP Constant Value 13	2.0000000	
SP Constant Value 14	0.4000000	
SP Constant Value 15	30.0000000	

Figure 11 - Screen Capture of Constant Data List Setpoints

4.7. Variable Data List Setpoints

The Variable Data List Function Block is provided to allow the user to select values as desired for various logic block functions and defining rule for updating this data at run time. This functionality is explained in more detail in section 1.10.

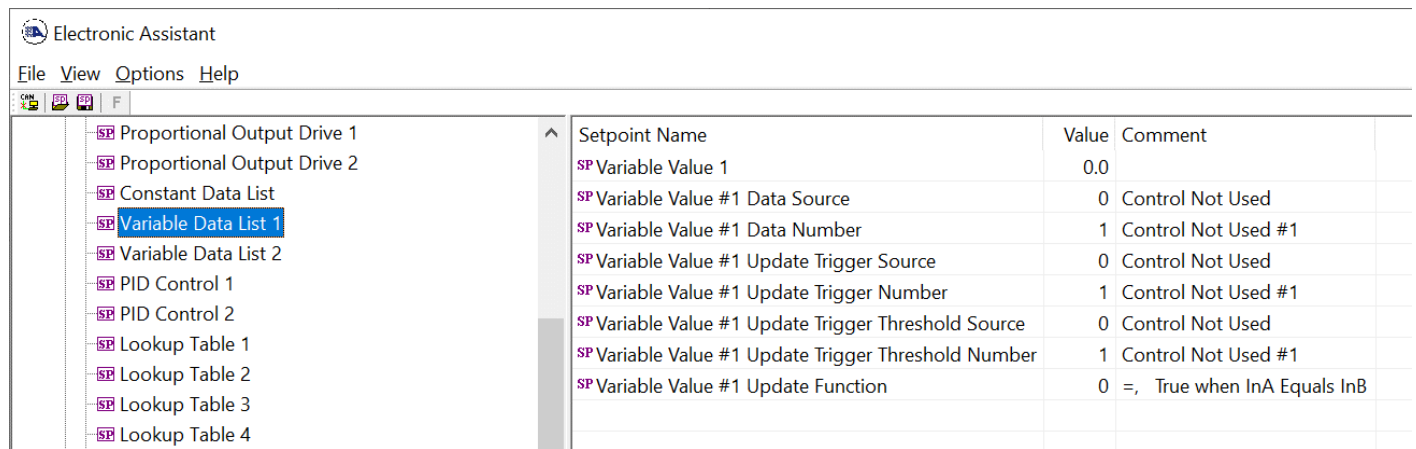

Figure 12 – Screen Capture of Variable Data List Setpoints

Name	Range	Default	Notes
Variable Value		0	
Variable Value Data Source	Drop List	Control Not Used	See Table 23
Variable Value Data Number	Depends on control source	1	See Table 23
Variable Value Update Trigger Source	Drop List	Control Not Used	See Table 23
Variable Value Update Trigger Number	Depends on control source	1	See Table 23
Variable Value Update Trigger Threshold Source	Drop List	Control Not Used	See Table 23
Variable Value Update Trigger Threshold Number	Depends on control source	1	See Table 23
Variable Value Update Function	0...17	0	See Table 22

Table 30 – Variable Data Setpoints

4.8. PID Control

The PID Control Function Block is defined in Section 1.6. Please refer there for detailed information about how all these setpoints are used.

Command Source is set to 'Control Not Used' by default. To enable a PID Control, select appropriate "PID Target Command Source" and "PID Feedback Input Source".

Setpoint Name	Value	Comment
SP PID Target Command Source	8	Control Constant Data
SP PID Target Command Number	3	Control Constant Data #3
SP PID Feedback Input Source	2	Universal Input Measured
SP PID Feedback Input Number	1	Universal Input Measured #1
SP PID Enable Source	0	Control Not Used
SP PID Enable Number		Parameter not used with current Enable Source selected
SP PID Enable Limit Source		Parameter not used with current Enable Source selected
SP PID Enable Limit Number		Parameter not used with current Enable Source selected
SP PID Enable Limit Parameter		Parameter not used with current Enable Source selected
SP PID Response Profile	0	Single Output
SP PID Delta Tolerance	1.00	%
SP PID Loop Update Rate	10	ms
SP PID Gain Coefficient, G	0.5	
SP PID Integral Time Coefficient, Ti	0.005	Sec
SP PID Derivative Time Coefficient, Td	0.001	Sec
SP PID Integral Coefficient, Ki	1.000	
SP PID Derivative Coefficient, Kd	1.000	

Figure 13 – Screen Capture of PID Control Setpoints

Name	Range	Default	Notes
PID Target Command Source	Drop List	Control Not Used	See Table 23
PID Target Command Number	Depends on control source	1	See Table 23
PID Feedback Input Source	Drop List	Control Not Used	See Table 23
PID Feedback Input Number	Depends on control source	1	See Table 23
PID Enable Source	Drop List	Control Not Used	See Table 23
PID Enable Number	Depends on control source	1	See Table 23
PID Enable Limit Source	Drop List	Control Not Used	See Table 23
PID Enable Limit Number	Depends on control source	1	See Table 23
PID Enable Limit Parameter	Drop List	0	
PID Response Profile	Drop List	Single Output	See Table 17
PID Delta Tolerance	0 to 100	1.00 %	%
PID Loop Update Rate	1 to 60 000 ms	10ms	1 ms resolution
PID Gain Coefficient, G	0.1 to 1000	0.5	See Equation 4
PID Integral Time Coefficient, Ti	0.001 to 10 Sec	0.005 Sec	0.001 Sec (1ms) resolution
PID Derivative Time Coefficient, Td	0.001 to 10 Sec	0.001 Sec	0.001 Sec (1ms) resolution
PID Integral Coefficient, Ki	0 to 10	1.000	0 disables integral, PD ctrl
PID Derivative Coefficient, Kd	0 to 10	1.000	0 disables derivative, PI ctrl

Table 31 – Programmable Logic Setpoints

4.9. Lookup Table

The Lookup Table Function Block is defined in Section 1.7. Please refer there for detailed information about how all these setpoints are used. “**X-Axis Source**” is set to ‘*Control Not Used*’ by default. To enable a Lookup Table, select appropriate “**X-Axis Source**”.

Electronic Assistant

File View Options Help

J1939 CAN Network

ECU AX102100, 40A Bidirectional DC Motor Controller #1

- General ECU Information
- Setpoint File
 - J1939 Network
 - Motor Drive
 - Universal Input 1
 - Universal Input 2
 - Digital Input 1
 - Digital Input 2
 - Digital Input 3
 - Proportional Output Drive 1
 - Proportional Output Drive 2
 - Constant Data List
 - Variable Data List 1
 - Variable Data List 2
 - PID Control 1
 - PID Control 2
 - Lookup Table 1**
 - Lookup Table 2
 - Lookup Table 3
 - Lookup Table 4
 - Programmable Logic 1
 - Programmable Logic 2
 - Math Function Block 1
 - Math Function Block 2
 - Small Math Function Block 3
 - Small Math Function Block 4
 - Small Math Function Block 5
 - Small Math Function Block 6
 - CAN Transmit 1
 - CAN Transmit 2
 - CAN Transmit 3
 - CAN Transmit 4
 - CAN Transmit 5
 - CAN Transmit 6
 - CAN Receive 1
 - CAN Receive 2
 - CAN Receive 3
 - CAN Receive 4
 - CAN Receive 5
 - CAN Receive 6

Setpoint Name	Value	Comment
SP X-Axis Source	2	Universal Input Measured
SP X-Axis Number	1	Universal Input Measured #1
SP X-Axis Type	0	Data Response
SP Disable limit (X Value)		Parameter not used with current Control Source selected
SP Enable limit (X Value)		Parameter not used with current Control Source selected
SP Output value when disabled		Parameter not used with current Control Source selected
SP Table Auto-Cycle		Parameter not used with selected X-Axis Type
SP Point 1 - Response	1	Ramp To
SP Point 2 - Response	1	Ramp To
SP Point 3 - Response	1	Ramp To
SP Point 4 - Response	1	Ramp To
SP Point 5 - Response	1	Ramp To
SP Point 6 - Response	1	Ramp To
SP Point 7 - Response	1	Ramp To
SP Point 8 - Response	1	Ramp To
SP Point 9 - Response	1	Ramp To
SP Point 10 - Response	1	Ramp To
SP Point 0 - X Value	0.000	
SP Point 1 - X Value	0.500	
SP Point 2 - X Value	1.000	
SP Point 3 - X Value	1.500	
SP Point 4 - X Value	2.000	
SP Point 5 - X Value	2.500	
SP Point 6 - X Value	3.000	
SP Point 7 - X Value	3.500	
SP Point 8 - X Value	4.000	
SP Point 9 - X Value	4.500	
SP Point 10 - X Value	5.000	
SP Point 0 - Y Value	0.000	
SP Point 1 - Y Value	10.000	
SP Point 2 - Y Value	20.000	
SP Point 3 - Y Value	30.000	
SP Point 4 - Y Value	40.000	
SP Point 5 - Y Value	50.000	
SP Point 6 - Y Value	60.000	
SP Point 7 - Y Value	70.000	
SP Point 8 - Y Value	80.000	
SP Point 9 - Y Value	90.000	
SP Point 10 - Y Value	100.000	

Figure 14 – Screen Capture of Lookup table Setpoints

Name	Range	Default	Notes
X-Axis Source	Drop List	Control Not Used	See Table 23
X-Axis Number	Depends on control source	1	See Table 23
X-Axis Type	Drop List	Data Response	See Table 18
Table Auto-Cycle	Drop List	0	
Point 1 - Response	Drop List	Ramp To	See Table 19
Point 2 - Response	Drop List	Ramp To	See Table 19
Point 3 - Response	Drop List	Ramp To	See Table 19
Point 4 - Response	Drop List	Ramp To	See Table 19
Point 5 - Response	Drop List	Ramp To	See Table 19
Point 6 - Response	Drop List	Ramp To	See Table 19
Point 7 - Response	Drop List	Ramp To	See Table 19
Point 8 - Response	Drop List	Ramp To	See Table 19
Point 9 - Response	Drop List	Ramp To	See Table 19
Point 10 - Response	Drop List	Ramp To	See Table 19
Point 0 - X Value	From X-Axis source minimum to Point 1 - X Value	X-Axis source minimum 0.000	See Section 1.7
Point 1 - X Value	From Point 0 - X Value to Point 2 - X Value	0.500	See Section 1.7
Point 2 - X Value	From Point 1 - X Value to Point 3 - X Value	1.000	See Section 1.7
Point 3 - X Value	From Point 2 - X Value to Point 4 - X Value	1.500	See Section 1.7
Point 4 - X Value	From Point 3 - X Value to Point 5 - X Value source	2.000	See Section 1.7
Point 5 - X Value	From Point 4 - X Value to Point 6 - X Value	2.500	See Section 1.7
Point 6 - X Value	From Point 5 - X Value to Point 7 - X Value	3.000	See Section 1.7
Point 7 - X Value	From Point 6 - X Value to Point 8 - X Value	3.500	See Section 1.7
Point 8 - X Value	From Point 7 - X Value to Point 9 - X Value	4.000	See Section 1.7
Point 9 - X Value	From Point 8 - X Value to Point 10 - X Value	4.500	See Section 1.7
Point 10 - X Value	From Point 9 - X Value to X-Axis source maximum	X-Axis source maximum 5.000	See Section 1.7
Point 0 - Y Value	-10 ⁶ to 10 ⁶	0.000	
Point 1 - Y Value	-10 ⁶ to 10 ⁶	10.000	
Point 2 - Y Value	-10 ⁶ to 10 ⁶	20.000	
Point 3 - Y Value	-10 ⁶ to 10 ⁶	30.000	
Point 4 - Y Value	-10 ⁶ to 10 ⁶	40.000	
Point 5 - Y Value	-10 ⁶ to 10 ⁶	50.000	
Point 6 - Y Value	-10 ⁶ to 10 ⁶	60.000	
Point 7 - Y Value	-10 ⁶ to 10 ⁶	70.000	
Point 8 - Y Value	-10 ⁶ to 10 ⁶	80.000	
Point 9 - Y Value	-10 ⁶ to 10 ⁶	90.000	
Point 10 - Value	-10 ⁶ to 10 ⁶	100.000	

Table 32 – Lookup Table Setpoints

4.10. Programmable Logic

The Programmable Logic function block is defined in Section 1.8. Please refer there for detailed information about how all these setpoints are used. **“Programmable Logic Enabled”** is *‘False’* by default. To enable Logic set **“Programmable Logic Enabled”** to *‘True’* and select appropriate **“Argument Source”**.

Setpoint Name	Value	Comment
SP Programmable Logic Enabled	1	True
SP Table 1 - Lookup Table Block Number	1	Lookup Table 1
SP Table 1 - Conditions Logical Operator	1	Cnd1 And Cnd2 And Cnd3
SP Table 1 - Condition 1, Argument 1 Source	0	Control Not Used
SP Table 1 - Condition 1, Argument 1 Number		Parameter not used with current Control Source selected
SP Table 1 - Condition 1, Operator		Parameter not used with current Control Source selected
SP Table 1 - Condition 1, Argument 2 Source	0	Control Not Used
SP Table 1 - Condition 1, Argument 2 Number		Parameter not used with current Control Source selected
SP Table 1 - Condition 2, Argument 1 Source	0	Control Not Used
SP Table 1 - Condition 2, Argument 1 Number		Parameter not used with current Control Source selected
SP Table 1 - Condition 2, Operator		Parameter not used with current Control Source selected
SP Table 1 - Condition 2, Argument 2 Source	0	Control Not Used
SP Table 1 - Condition 2, Argument 2 Number		Parameter not used with current Control Source selected
SP Table 1 - Condition 3, Argument 1 Source	0	Control Not Used
SP Table 1 - Condition 3, Argument 1 Number		Parameter not used with current Control Source selected
SP Table 1 - Condition 3, Operator		Parameter not used with current Control Source selected
SP Table 1 - Condition 3, Argument 2 Source	0	Control Not Used
SP Table 1 - Condition 3, Argument 2 Number		Parameter not used with current Control Source selected
SP Table 2 - Lookup Table Block Number	2	Lookup Table 2
SP Table 2 - Conditions Logical Operator	1	Cnd1 And Cnd2 And Cnd3
SP Table 2 - Condition 1, Argument 1 Source	0	Control Not Used
SP Table 2 - Condition 1, Argument 1 Number		Parameter not used with current Control Source selected
SP Table 2 - Condition 1, Operator		Parameter not used with current Control Source selected
SP Table 2 - Condition 1, Argument 2 Source	0	Control Not Used
SP Table 2 - Condition 1, Argument 2 Number		Parameter not used with current Control Source selected
SP Table 2 - Condition 2, Argument 1 Source	0	Control Not Used
SP Table 2 - Condition 2, Argument 1 Number		Parameter not used with current Control Source selected
SP Table 2 - Condition 2, Operator		Parameter not used with current Control Source selected
SP Table 2 - Condition 2, Argument 2 Source	0	Control Not Used
SP Table 2 - Condition 2, Argument 2 Number		Parameter not used with current Control Source selected
SP Table 2 - Condition 3, Argument 1 Source	0	Control Not Used
SP Table 2 - Condition 3, Argument 1 Number		Parameter not used with current Control Source selected
SP Table 2 - Condition 3, Operator		Parameter not used with current Control Source selected
SP Table 2 - Condition 3, Argument 2 Source	0	Control Not Used
SP Table 2 - Condition 3, Argument 2 Number		Parameter not used with current Control Source selected
SP Table 3 - Lookup Table Block Number	3	Lookup Table 3
SP Table 3 - Conditions Logical Operator	1	Cnd1 And Cnd2 And Cnd3
SP Table 3 - Condition 1, Argument 1 Source	0	Control Not Used
SP Table 3 - Condition 1, Argument 1 Number		Parameter not used with current Control Source selected
SP Table 3 - Condition 1, Operator		Parameter not used with current Control Source selected

Figure 15 – Screen Capture of Programmable Logic Setpoints

Setpoint ranges and default values for Programmable Logic Blocs are listed in Table 33. Only “**Table1**” setpoint are listed, because other “**TableX**” setpoints are similar, except for the default value of the “**Lookup Table Block Number**” setpoint, which is X for “**TableX**”.

Name	Range	Default	Notes
Programmable Logic Enabled	Drop List	False	
Table1 - Lookup Table Block Number	1 to 4	Look up Table 1	
Table1 - Conditions Logical Operation	Drop List	Default Table	See Table 21
Table1 - Condition1, Argument 1 Source	Drop List	Control Not Used	See Table 23
Table1 - Condition1, Argument 1 Number	Depends on control source	1	See Table 23
Table1 - Condition1, Operator	Drop List	=, Equal	See Table 20
Table1 - Condition1, Argument 2 Source	Drop List	Control Not Used	See Table 23
Table1 - Condition1, Argument 2 Number	Depends on control source	1	See Table 23
Table1 - Condition2, Argument 1 Source	Drop List	Control Not Used	See Table 23
Table1 - Condition2, Argument 1 Number	Depends on control source	1	See Table 23
Table1 - Condition2, Operator	Drop List	=, Equal	See Table 20
Table1 - Condition2, Argument 2 Source	Drop List	Control Not Used	See Table 23
Table1 - Condition2, Argument 2 Number	Depends on control source	1	See Table 23
Table1 - Condition3, Argument 1 Source	Drop List	Control Not Used	See Table 23
Table1 - Condition3, Argument 1 Number	Depends on control source	1	See Table 23
Table1 - Condition3, Operator	Drop List	=, Equal	See Table 20
Table1 - Condition3, Argument 2 Source	Drop List	Control Not Used	See Table 23
Table1 - Condition3, Argument 2 Number	Depends on control source	1	See Table 23

Table 33 – Programmable Logic Setpoints

4.11. Math Function Block

The Math Function Block is defined in Section 1.9. Please refer there for detailed information about how all these setpoints are used. **“Math Function Enabled”** is ‘False’ by default. To enable a Math Function Block, set **“Math Function Enabled”** to ‘True’ and select appropriate **“Input Source”**.

Setpoint Name	Value	Comment
SP Math Function Enabled	1	True
SP Function 1 Input A Source	0	Control Not Used
SP Function 1 Input A Number		Parameter not used with current Control Source selected
SP Function 1 Input A Minimum		Parameter not used with current Control Source selected
SP Function 1 Input A Maximum		Parameter not used with current Control Source selected
SP Function 1 Input A Scaler		Parameter not used with current Control Source selected
SP Function 1 Input B Source	0	Control Not Used
SP Function 1 Input B Number		Parameter not used with current Control Source selected
SP Function 1 Input B Minimum		Parameter not used with current Control Source selected
SP Function 1 Input B Maximum		Parameter not used with current Control Source selected
SP Function 1 Input B Scaler		Parameter not used with current Control Source selected
SP Math Function 1 Operation		Parameter not used with current Control Source selected
SP Function 2 Input B Source	0	Control Not Used
SP Function 2 Input B Number		Parameter not used with current Control Source selected
SP Function 2 Input B Minimum		Parameter not used with current Control Source selected
SP Function 2 Input B Maximum		Parameter not used with current Control Source selected
SP Function 2 Input B Scaler		Parameter not used with current Control Source selected
SP Math Function 2 Operation (Input A = Result of Function 1)		Parameter not used with current Control Source selected
SP Function 3 Input B Source	0	Control Not Used
SP Function 3 Input B Number		Parameter not used with current Control Source selected
SP Function 3 Input B Minimum		Parameter not used with current Control Source selected
SP Function 3 Input B Maximum		Parameter not used with current Control Source selected
SP Function 3 Input B Scaler		Parameter not used with current Control Source selected
SP Math Function 3 Operation (Input A = Result of Function 2)		Parameter not used with current Control Source selected
SP Function 4 Input B Source	0	Control Not Used
SP Function 4 Input B Number		Parameter not used with current Control Source selected
SP Function 4 Input B Minimum		Parameter not used with current Control Source selected
SP Function 4 Input B Maximum		Parameter not used with current Control Source selected
SP Function 4 Input B Scaler		Parameter not used with current Control Source selected
SP Math Function 4 Operation (Input A = Result of Function 3)		Parameter not used with current Control Source selected
SP Math Output Minimum Range	0.00	
SP Math Output Maximum Range	1000.00	

Figure 16 – Screen Capture of Math Function Block Setpoints

Name	Range	Default	Notes
Math Function Enabled	Drop List	False	
Function 1 Input A Source	Drop List	Control not used	See Table 23
Function 1 Input A Number	Depends on control source	1	See Table 23
Function 1 Input A Minimum	-10 ⁶ to 10 ⁶	0.0	
Function 1 Input A Maximum	-10 ⁶ to 10 ⁶	100.0	
Function 1 Input A Scaler	-1.00 to 1.00	1.00	
Function 1 Input B Source	Drop List	Control not used	See Table 23
Function 1 Input B Number	Depends on control source	1	See Table 23
Function 1 Input B Minimum	-10 ⁶ to 10 ⁶	0.0	
Function 1 Input B Maximum	-10 ⁶ to 10 ⁶	100.0	
Function 1 Input B Scaler	-1.00 to 1.00	1.00	
Math Function 1 Operation	Drop List	=, True when InA Equals InB	See Table 22
Function 2 Input B Source	Drop List	Control not used	See Table 23
Function 2 Input B Number	Depends on control source	1	See Table 23
Function 2 Input B Minimum	-10 ⁶ to 10 ⁶	0.0	
Function 2 Input B Maximum	-10 ⁶ to 10 ⁶	100.0	
Function 2 Input B Scaler	-1.00 to 1.00	1.00	
Math Function 3 Operation	Drop List	=, True when InA Equals InB	See Table 22
Function 3 Input B Source	Drop List	Control not used	See Table 23
Function 3 Input B Number	Depends on control source	1	See Table 23
Function 3 Input B Minimum	-10 ⁶ to 10 ⁶	0.0	
Function 3 Input B Maximum	-10 ⁶ to 10 ⁶	100.0	
Function 3 Input B Scaler	-1.00 to 1.00	1.00	
Math Function 3 Operation	Drop List	=, True when InA Equals InB	See Table 22
Function 4 Input B Source	Drop List	Control not used	See Table 23
Function 4 Input B Number	Depends on control source	1	See Table 23
Function 4 Input B Minimum	-10 ⁶ to 10 ⁶	0.0	
Function 4 Input B Maximum	-10 ⁶ to 10 ⁶	100.0	
Function 4 Input B Scaler	-1.00 to 1.00	1.00	
Math Function 4 Operation	Drop List	=, True when InA Equals InB	See Table 22
Math Output Minimum Range	-10 ⁶ to 10 ⁶	0.0	
Math Output Maximum Range	-10 ⁶ to 10 ⁶	100.0	

Table 34 – Math Function Setpoints

4.12. Small Math Function Block

The Math Function Block is defined in Section 1.9. Please refer there for detailed information about how all these setpoints are used. “**Math Function Enabled**” is ‘False’ by default. To enable a Math Function Block, set “**Math Function Enabled**” to ‘True’ and select appropriate “**Input Source**”.

Setpoint Name	Value	Comment
SP Math Function Enabled	1	True
SP Function 1 Input A Source	0	Control Not Used
SP Function 1 Input A Number		Parameter not used with current Control Source selected
SP Function 1 Input A Minimum		Parameter not used with current Control Source selected
SP Function 1 Input A Maximum		Parameter not used with current Control Source selected
SP Function 1 Input A Scaler		Parameter not used with current Control Source selected
SP Function 1 Input B Source	0	Control Not Used
SP Function 1 Input B Number		Parameter not used with current Control Source selected
SP Function 1 Input B Minimum		Parameter not used with current Control Source selected
SP Function 1 Input B Maximum		Parameter not used with current Control Source selected
SP Function 1 Input B Scaler		Parameter not used with current Control Source selected
SP Math Function 1 Operation		Parameter not used with current Control Source selected
SP Math Output Minimum Range	-100.00	
SP Math Output Maximum Range	100.00	

Figure 17 – Screen Capture of Small Math Function Block Setpoints

Name	Range	Default	Notes
Math Function Enabled	Drop List	False	
Function 1 Input A Source	Drop List	Control not used	See Table 23
Function 1 Input A Number	Depends on control source	1	See Table 23
Function 1 Input A Minimum	-10^6 to 10^6	0.0	
Function 1 Input A Maximum	-10^6 to 10^6	100.0	
Function 1 Input A Scaler	-1.00 to 1.00	1.00	
Function 1 Input B Source	Drop List	Control not used	See Table 23
Function 1 Input B Number	Depends on control source	1	See Table 23
Function 1 Input B Minimum	-10^6 to 10^6	0.0	
Function 1 Input B Maximum	-10^6 to 10^6	100.0	
Function 1 Input B Scaler	-1.00 to 1.00	1.00	
Math Function 1 Operation	Drop List	=, True when InA Equals InB	See Table 22
Math Output Minimum Range	-10^6 to 10^6	0.0	
Math Output Maximum Range	-10^6 to 10^6	100.0	

Table 35 – Math Function Setpoints

4.13. CAN Transmit Setpoints

CAN Transmit Message Function Block is presented in section 1.12. Please refer there for detailed information how these setpoints are used. **“Transmit Repetition Rate”** is 0ms by default, thus no message will be sent.

Setpoint Name	Value	Comment
SP Transmit PGN	0xFF00	Transmit PGN: 65280
SP Transmit Repetition Rate	100	ms
SP Transmit Message Priority	6	
SP Destination Address (PDU1)	0	Destination ECU Address: 0x0
SP Signal 1 Data Source	2	Universal Input Measured
SP Signal 1 Data Number	1	Universal Input Measured #1
SP Signal 1 Transmit Data Type	2	CAN signal continuous
SP Signal 1 Transmit Data Width	16	
SP Signal 1 Transmit Data Index in Array (LSB)	0	1st Byte Position
SP Signal 1 Transmit Bit Index in Byte (LSB)	0	1st Bit Position
SP Signal 1 Transmit Data Resolution	0.0010000	
SP Signal 1 Transmit Data Offset	0.0000000	
SP Signal 1 Transmit Data Minimum	0.0000000	
SP Signal 1 Transmit Data Maximum	10.0000000	
SP Signal 2 Data Source	2	Universal Input Measured
SP Signal 2 Data Number	2	Universal Input Measured #2
SP Signal 2 Transmit Data Type	2	CAN signal continuous
SP Signal 2 Transmit Data Width	16	
SP Signal 2 Transmit Data Index in Array (LSB)	2	3rd Byte Position
SP Signal 2 Transmit Bit Index in Byte (LSB)	0	1st Bit Position
SP Signal 2 Transmit Data Resolution	0.0010000	
SP Signal 2 Transmit Data Offset	0.0000000	
SP Signal 2 Transmit Data Minimum	0.0000000	
SP Signal 2 Transmit Data Maximum	10.0000000	
SP Signal 3 Data Source	0	Control Not Used
SP Signal 3 Data Number		Parameter not used with current Data Source
SP Signal 3 Transmit Data Type		Parameter not used with current Data Source
SP Signal 3 Transmit Data Width		Parameter not used with current Data Source
SP Signal 3 Transmit Data Index in Array (LSB)		Parameter not used with current Data Source
SP Signal 3 Transmit Bit Index in Byte (LSB)		Parameter not used with current Data Source
SP Signal 3 Transmit Data Resolution		Parameter not used with current Data Source
SP Signal 3 Transmit Data Offset		Parameter not used with current Data Source
SP Signal 3 Transmit Data Minimum		Parameter not used with current Data Source
SP Signal 3 Transmit Data Maximum		Parameter not used with current Data Source
SP Signal 4 Data Source	0	Control Not Used
SP Signal 4 Data Number		Parameter not used with current Data Source
SP Signal 4 Transmit Data Type		Parameter not used with current Data Source
SP Signal 4 Transmit Data Width		Parameter not used with current Data Source
SP Signal 4 Transmit Data Index in Array (LSB)		Parameter not used with current Data Source
SP Signal 4 Transmit Bit Index in Byte (LSB)		Parameter not used with current Data Source
SP Signal 4 Transmit Data Resolution		Parameter not used with current Data Source
SP Signal 4 Transmit Data Offset		Parameter not used with current Data Source
SP Signal 4 Transmit Data Minimum		Parameter not used with current Data Source
SP Signal 4 Transmit Data Maximum		Parameter not used with current Data Source

Figure 18 – Screen Capture of CAN Transmit Message Setpoints

Name	Range	Default	Notes
Transmit PGN	0xff00 ... 0xffff	Different for each	See Section 1.12.1
Transmit Repetition Rate	0 ... 65000 ms	0ms	0ms disables transmit
Transmit Message Priority	0...7	6	Proprietary B Priority
Destination Address	0...255	255	Not used by default
Signal 1 Control Source	Drop List	Different for each	See Table 23
Signal 1 Control Number	Drop List	Different for each	See 1.12.2
Signal 1 Transmit Data Type	Drop List	0	
Signal 1 Transmit Data Width	1-32	1	
Signal 1 Transmit Data Index in Array	0-7	2	
Signal 1 Transmit Bit Index In Byte	0-7	0	
Signal 1 Transmit Data Resolution	-100000.0 to 100000	0.001	
Signal 1 Transmit Data Offset	-10000 to 10000	0.0	
Signal 2 Control Source	Drop List	Signal undefined	See Table 23
Signal 2 Control Number	Drop List	Signal undefined	See 1.12.2
Signal 2 Transmit Data Type	Drop List	0	
Signal 2 Transmit Data Width	1-32	1	
Signal 2 Transmit Data Index in Array	0-7	0	
Signal 2 Transmit Bit Index In Byte	0-7	0	
Signal 2 Transmit Data Resolution	-100000.0 to 100000	0.001	
Signal 2 Transmit Data Offset	-10000 to 10000	0.0	
Signal 3 Control Source	Drop List	Signal undefined	See Table 23
Signal 3 Control Number	Drop List	Signal undefined	See 1.12.2
Signal 3 Transmit Data Type	Drop List	0	
Signal 3 Transmit Data Width	1-32	1	
Signal 3 Transmit Data Index in Array	0-7	0	
Signal 3 Transmit Bit Index In Byte	0-7	0	
Signal 3 Transmit Data Resolution	-100000.0 to 100000	0.001	
Signal 3 Transmit Data Offset	-10000 to 10000	0.0	
Signal 4 Control Source	Drop List	Signal undefined	See Table 23
Signal 4 Control Number	Drop List	Signal undefined	See 1.12.2
Signal 4 Transmit Data Type	Drop List	0	
Signal 4 Transmit Data Width	1-32	1	
Signal 4 Transmit Data Index in Array	0-7	0	
Signal 4 Transmit Bit Index In Byte	0-7	0	
Signal 4 Transmit Data Resolution	-100000.0 to 100000	0.001	
Signal 4 Transmit Data Offset	-10000 to 10000	0.0	

Table 36 – CAN Transmit Message Setpoints

4.14. CAN Receive Setpoints

The Math Function Block is defined in Section 1.13. Please refer there for detailed information about how these setpoints are used. **“Receive Message Timeout”** is set to 0ms by default. To enable Receive message set **“Receive Message Timeout”** that differs from zero.

Setpoint Name	Value	Comment
SP Receive Message Enabled	1	True
SP Receive PGN	0xFF80	Received PGN: 65408
SP Receive Message Timeout	0	ms
SP Address That Sends	0	False
SP Specific Address That Sends		Parameter not used - Receive from Source Address is Disabled
SP Receive Data Type	1	CAN signal discrete
SP Receive Data Width	3	
SP Receive Data Index in Array	0	1st Byte Position
SP Receive Bit Index in Byte	0	1st Bit Position
SP Receive Data Resolution	1.0000000	
SP Receive Data Offset	0.0000000	
SP Receive Data Min (OFF Threshold)	0.0000000	
SP Receive Data Max (ON Threshold)	7.0000000	

Figure 19 – Screen Capture of CAN Receive Message Setpoints

Name	Range	Default	Notes
Received Message Enabled	Drop List	False	
Received PGN	0 to 65536	Different for each	
Received Message Timeout	0 to 60 000 ms	0ms	
Specific Address that sends PGN	Drop List	False	
Address That Sends	0 to 255	254 (0xFE, Null Addr)	
Receive Data Type	Drop List	0	
Receive Data Width	1-32	1	
Receive Data Index in Array	0-7	0	
Receive Transmit Bit Index In Byte	0-7	0	
Receive Transmit Data Resolution	-100000.0 to 100000	0.001	
Receive Transmit Data Offset	-10000 to 10000	0.0	
Receive Data Min (Off Threshold)	-1000000 to Max	0.0	
Receive Data Max (On Threshold)	-100000 to 100000	2.0	

Table 37 – CAN Receive Setpoints

4.15. DTC React

The DTC React Function Block is defined in Section 1.11. Please refer there for detailed information about how these setpoints are used.

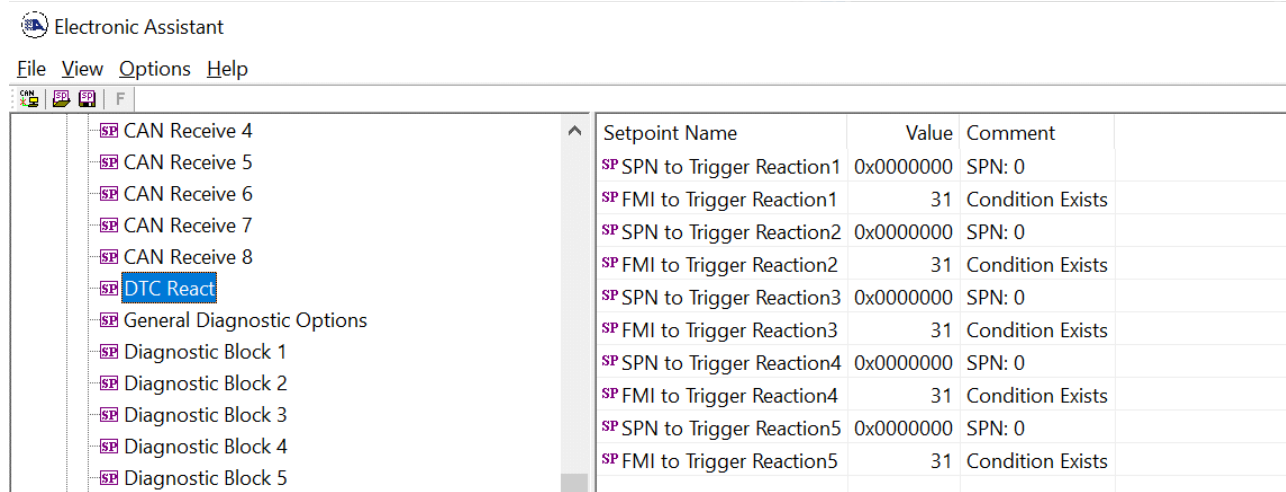

Figure 20 – Screen Capture of DTC React Setpoints

Name	Range	Default	Notes
SPN to Trigger Reaction #1	0 to 524287	0	0 is an illegal value, and disables the DTC
FMI to Trigger Reaction #X	Drop List	31, Condition Exists	Supports all FMIs in the J1939 standard

Table 38 – DTC React Setpoints

4.16. General Diagnostics Options

These setpoints control the shutdown of the ECU in case of a power supply or CPU temperature related errors. Refer to section 1.5 for more info.

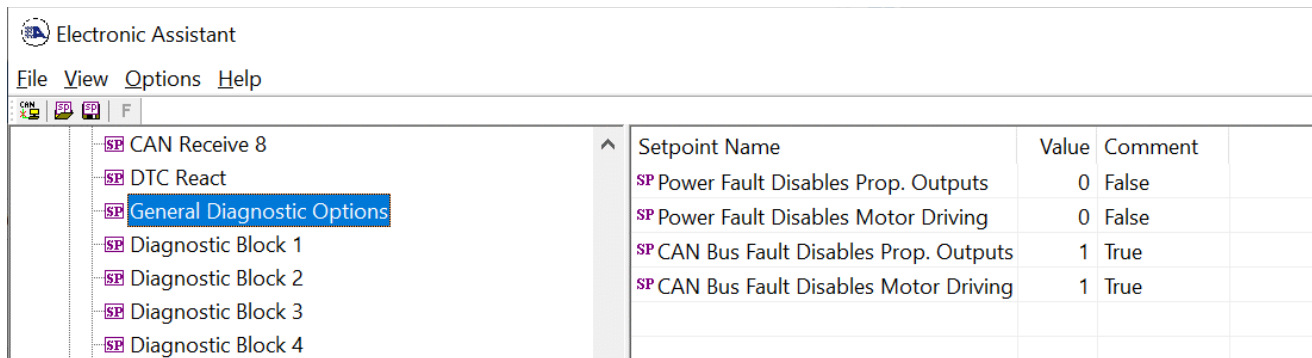

Figure 21 – Screen Capture of General Diagnostics Options Setpoints

Name	Range	Default	Notes
Power Fault Disables Prop. Outputs	Drop List	0	
Power Fault Disables Motor Driving	Drop List	0	
Over Temperature Shutdown	Drop List	0	
CAN Bus Fault Disables Prop. Outputs	Drop List	1	
CAN Bus Fault Disables Motor Driving	Drop List	1	

Table 39 – General Diagnostics Options Setpoints

4.17. Diagnostics Blocks

There are 8 Diagnostics blocks that can be configured to monitor various parameters of the Controller. The Diagnostic Function Block is defined in section 1.5. Please refer there for detailed information how these setpoints are used.

Setpoint Name	Value	Comment
SP Fault Detection is Enabled	1	True
SP Function Type to Monitor	12	Power Supply Measured
SP Function Parameter to Monitor	1	Power Supply Measured
SP Enable Source	0	Control Not Used
SP Enable Number		Parameter not used with current Enable Source selected
SP Enable Response		Parameter not used with current Enable Source selected
SP Fault Detection Type	4	Double Threshold Min and Max Error
SP Maximum Value for Diagnostic Data	54.00	
SP Minimum Value for Diagnostic Data	0.00	
SP Use Hysteresis When Defining Thresholds	1	True
SP Hysteresis	1.00	
SP Event Cleared Only by DM11	0	False
SP Set Limit for MAXIMUM SHUTDOWN	36.00	
SP Clear Limit for MAXIMUM SHUTDOWN		Parameter not used - Hysteresis used when defining thresholds
SP Set Limit for MAXIMUM WARNING	32.00	
SP Clear Limit for MAXIMUM WARNING		Parameter not used - Hysteresis used when defining thresholds
SP Clear Limit for MINIMUM WARNING		Parameter not used - Hysteresis used when defining thresholds
SP Set Limit for MINIMUM WARNING	10.00	
SP Clear Limit for MINIMUM SHUTDOWN		Parameter not used - Hysteresis used when defining thresholds
SP Set Limit for MINIMUM SHUTDOWN	8.00	
SP MAXIMUM SHUTDOWN, Event Generates a DTC in DM1	1	True
SP MAXIMUM SHUTDOWN, Lamp Set by Event	1	Amber,Warning
SP MAXIMUM SHUTDOWN, SPN for Event	0x0000064	SPN: 100
SP MAXIMUM SHUTDOWN, FMI for Event	3	Voltage Above Normal, Or Shorted To High Source
SP MAXIMUM SHUTDOWN, Delay Before Event is Flagged	1000	ms
SP MAXIMUM WARNING, Event Generates a DTC in DM1	1	True
SP MAXIMUM WARNING, Lamp Set by Event	1	Amber,Warning
SP MAXIMUM WARNING, SPN for Event	0x00000C8	SPN: 200
SP MAXIMUM WARNING, FMI for Event	3	Voltage Above Normal, Or Shorted To High Source
SP MAXIMUM WARNING, Delay Before Event is Flagged	1000	ms
SP MINIMUM WARNING, Event Generates a DTC in DM1	1	True
SP MINIMUM WARNING, Lamp Set by Event	1	Amber,Warning
SP MINIMUM WARNING, SPN for Event	0x000012C	SPN: 300
SP MINIMUM WARNING, FMI for Event	4	Voltage Below Normal, Or Shorted To Low Source
SP MINIMUM WARNING, Delay Before Event is Flagged	1000	ms
SP MINIMUM SHUTDOWN, Event Generates a DTC in DM1	1	True
SP MINIMUM SHUTDOWN, Lamp Set by Event	1	Amber,Warning
SP MINIMUM SHUTDOWN, SPN for Event	0x0000190	SPN: 400
SP MINIMUM SHUTDOWN, FMI for Event	4	Voltage Below Normal, Or Shorted To Low Source
SP MINIMUM SHUTDOWN, Delay Before Event is Flagged	1000	ms

Figure 22 – Screen Capture of Diagnostic Block Setpoints

Name	Range	Default	Notes
Fault Detection is Enabled	Drop List	False	
Function Type to Monitor	Drop List	0 – Control not used	
Function parameter to Monitor	Drop List	0 – No selection	
Fault Detection Type	Drop List	1 – Min and Max Error	See section 1.5
Maximum Value for Diagnostic Data	Minimum Value for Diagnostic Data ... 4.28e ⁹	5.0	
Minimum Value for Diagnostic Data	0.0 ... Maximum Value for Diagnostic Data	0.0	
Use Hysteresis When Defining Thresholds	Drop List	False	
Hysteresis	0.0 ... Maximum Value for Diagnostic Data	0.0	
Event Cleared only by DM11	Drop List	False	
Set Limit for MAXIMUM SHUTDOWN	Minimum Value for Diagnostic Data ... Maximum Value for Diagnostics Data	4.8	
Clear Limit for MAXIMUM SHUTDOWN	Minimum Value for Diagnostic Data ... Maximum Value for Diagnostics Data	4.6	
Set Limit for MAXIMUM WARNING	Minimum Value for Diagnostic Data ... Maximum Value for Diagnostics Data	0.0	
Clear Limit for MAXIMUM WARNING	Minimum Value for Diagnostic Data ... Maximum Value for Diagnostics Data	0.0	
Clear Limit for MINIMUM WARNING	Minimum Value for Diagnostic Data ... Maximum Value for Diagnostics Data	0.0	
Set Limit for MINIMUM WARNING	Minimum Value for Diagnostic Data ... Maximum Value for Diagnostics Data	0.0	
Clear Limit for MINIMUM SHUTDOWN	Minimum Value for Diagnostic Data ... Maximum Value for Diagnostics Data	0.4	
Set Limit for MINIMUM SHUTDOWN	Minimum Value for Diagnostic Data ... Maximum Value for Diagnostics Data	0.2	
MAXIMUM SHUTDOWN, Event Generates a DTC in DM1	Drop List	True	
MAXIMUM SHUTDOWN, Lamp Set by Event	Drop List	0 – Protect	See Table 14
MAXIMUM SHUTDOWN, SPN for Event	0...524287	520448 (\$7F100)	It is the user's responsibility to select an SPN that will not violate the J1939 standard.

MAXIMUM SHUTDOWN, FMI for Event	Drop List	3, Voltage Above Normal	See Table 15
MAXIMUM SHUTDOWN, Delay Before Event is Flagged	0...60000 ms	1000	
MAXIMUM WARNING, Event Generates a DTC in DM1	Drop List	True	
MAXIMUM WARNING, Lamp Set by Event	Drop List	0 – Protect	See Table 14
MAXIMUM WARNING, SPN for Event	0...524287	520704 (\$7F200)	It is the user's responsibility to select an SPN that will not violate the J1939 standard.
MAXIMUM WARNING, FMI for Event	Drop List	3, Voltage Above Normal	See Table 15
MAXIMUM WARNING, Delay Before Event is Flagged	0...60000 ms	1000	
MINIMUM WARNING, Event Generates a DTC in DM1	Drop List	True	
MINIMUM WARNING, Lamp Set by Event	Drop List	0 – Protect	See Table 14
MAXIMUM WARNING, SPN for Event	0...524287	520960 (\$7F300)	It is the user's responsibility to select an SPN that will not violate the J1939 standard.
MINIMUM WARNING, FMI for Event	Drop List	4, Voltage Below Normal	See Table 15
MINIMUM WARNING, Delay Before Event is Flagged	0...60000 ms	1000	
MINIMUM SHUTDOWN, Event Generates a DTC in DM1	Drop List	True	
MINIMUM SHUTDOWN, Lamp Set by Event	Drop List	Amber Warning	See Table 14
MINIMUM SHUTDOWN, SPN for Event	0...524287	521216 (\$7F400)	It is the user's responsibility to select an SPN that will not violate the J1939 standard.
MINIMUM SHUTDOWN, FMI for Event	Drop List	4, Voltage Below Normal	See Table 15
MINIMUM SHUTDOWN, Delay Before Event is Flagged	0...60000 ms	1000	

Table 40 – Diagnostic Block Setpoints

5. Reflashing Over CAN With EA Bootloader

The AX102100 can be upgraded with new application firmware using the **Bootloader Information** section in EA. This section of the user manual details the simple step-by-step instructions to upload new firmware provided by Axiomatic onto the unit via CAN, without requiring it to be disconnected from the J1939 network.

Note: To upgrade the firmware use Electronic Assistant®  V5.13.88.0 or higher.

1. When EA first connects to the ECU, the **Bootloader Information** section will display the following information.

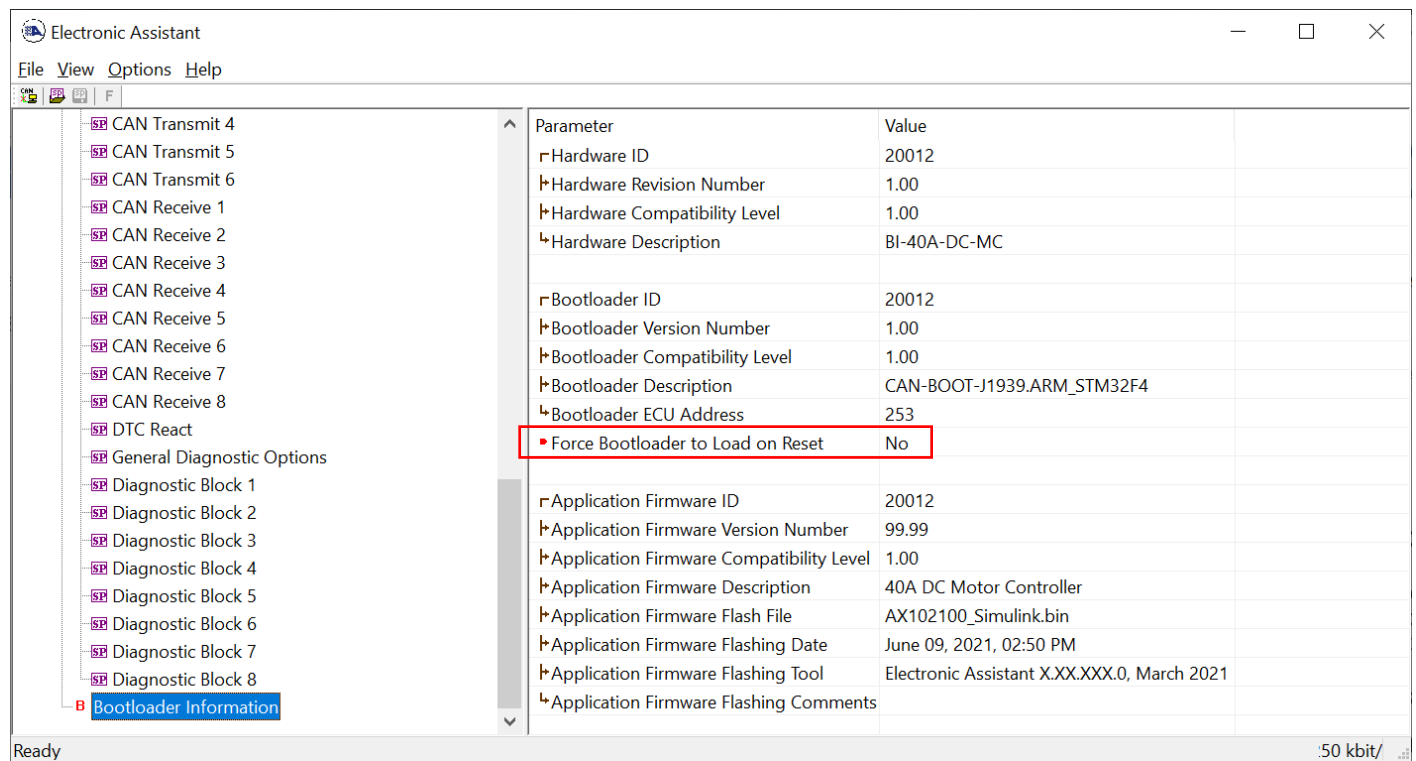

2. To use the bootloader to upgrade the firmware running on the ECU, change the variable **“Force Bootloader To Load on Reset”** to Yes.

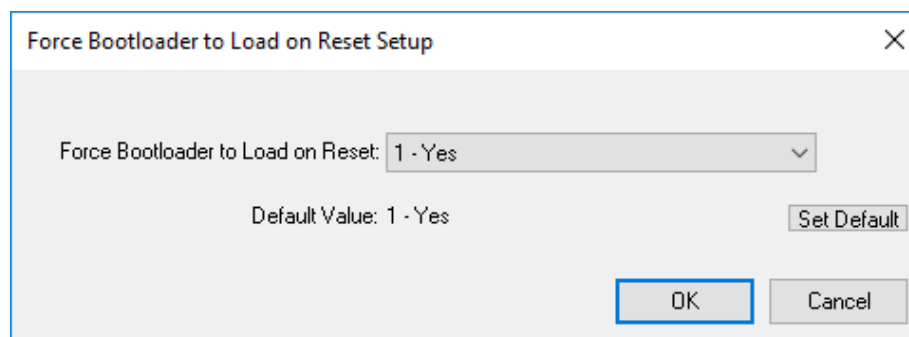

3. When the prompt box asks if you want to reset the ECU, select Yes.

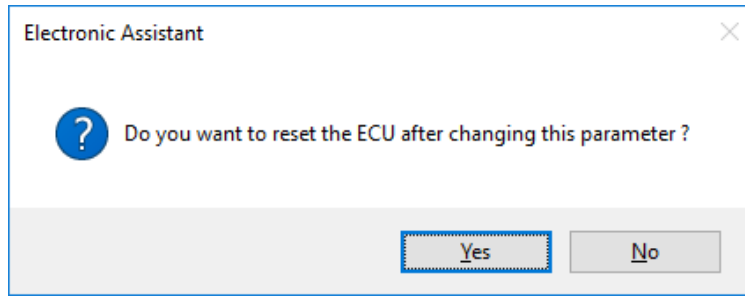

4. Upon reset, the ECU will no longer show up on the J1939 network as an AX102100 but rather as **J1939 Bootloader #1**.

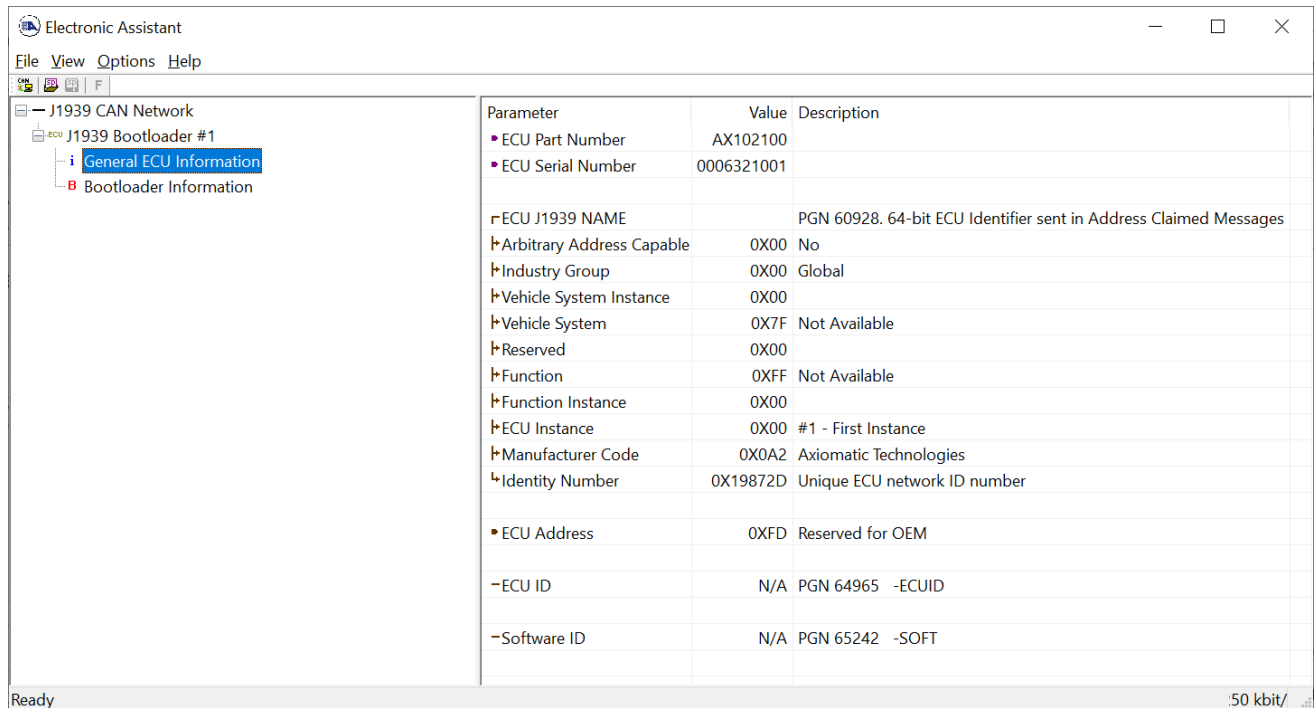
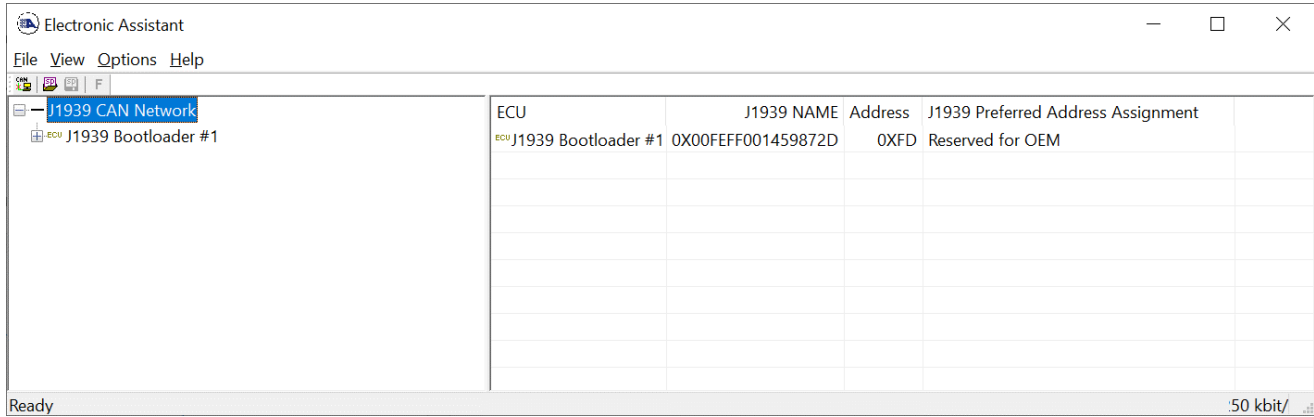

Note that the bootloader is NOT Arbitrary Address Capable. This means that if you want to have multiple bootloaders running simultaneously (not recommended) you would have to manually change the address for each one before activating the next, or there will be address conflicts. And only one ECU would show up as the bootloader. Once the 'active' bootloader returns to regular functionality, the other ECU(s) would have to be power cycled to re-activate the bootloader feature.

5. When the **Bootloader Information** section is selected, the same information is shown as when it was running the AX102100 firmware, but in this case the **Flashing** feature has been enabled.

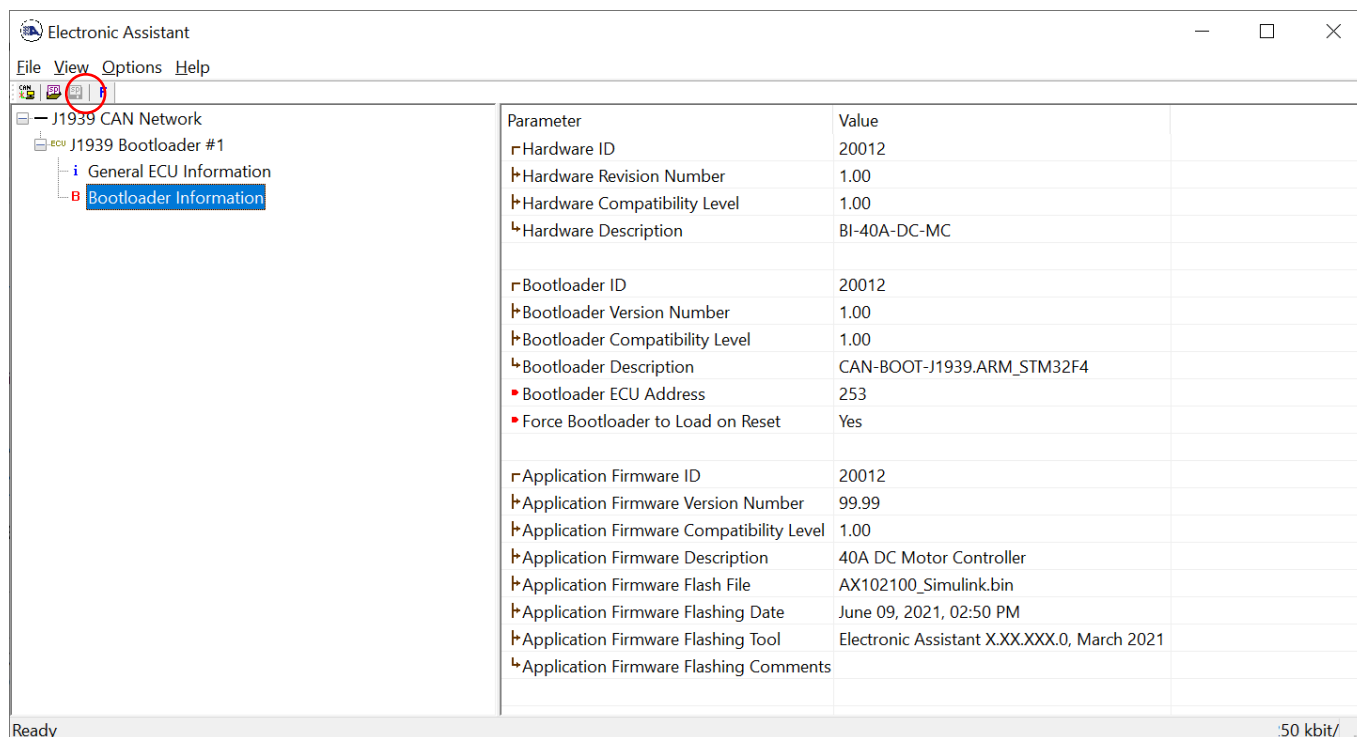

6. Select the **Flashing** button and navigate to where you had saved the **AF-20012-x.xx.bin** (or equivalent) file sent from Axiomatic. (Note: only binary (.bin) files can be flashed using the EA tool.)
7. Once the Flash Application Firmware window opens, you can enter comments such as “Firmware upgraded by [Name]” if you so desire. This is not required, and you can leave the field blank if you do not want to use it.

Note: You do not have to date/time-stamp the file, as this is done automatically by the EA tool when you upload the new firmware.

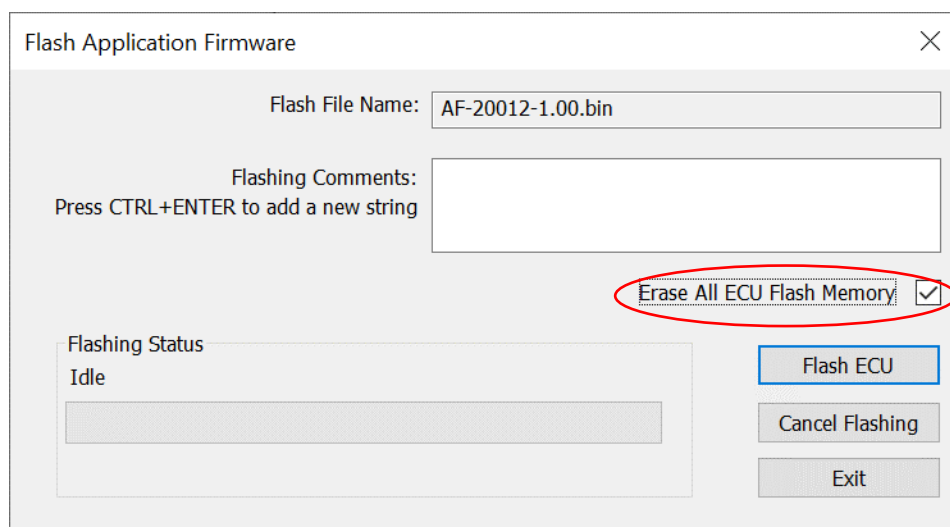



NOTE: It is good practice to tick the “Erase All ECU Flash Memory” box. Please note, that selecting this option will **erase ALL data stored in non-volatile flash**. It will also erase any configuration of the setpoints that might have been done to the ECU and reset all setpoints to their factory defaults. In case the controller contains custom settings, those settings need to be saved to PC before reflashing.

A progress bar will show how much of the firmware has been sent as the upload progresses. The more traffic there is on the J1939 network, the longer the upload process will take.

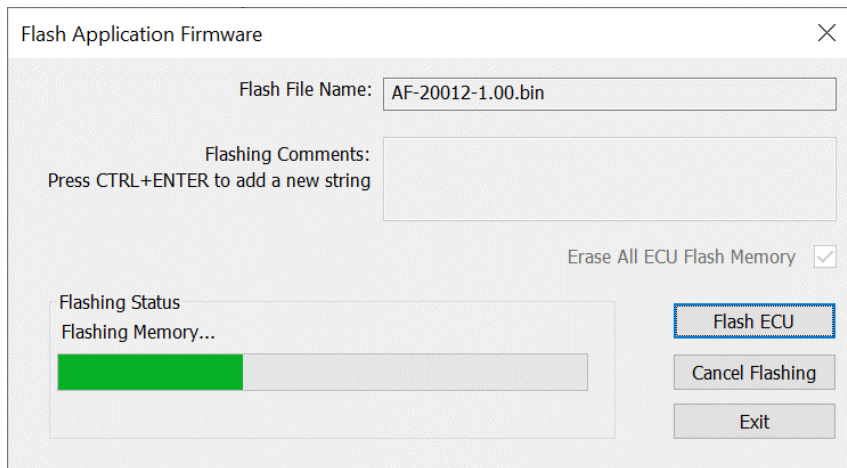

Once the firmware has finished uploading, a message will pop up indicating the successful operation. If you select to reset the ECU, the new version of the AX102100 application will start running, and the ECU will be identified as such by EA. Otherwise, the next time the ECU is power-cycled, the AX102100 application will run rather than the bootloader function.

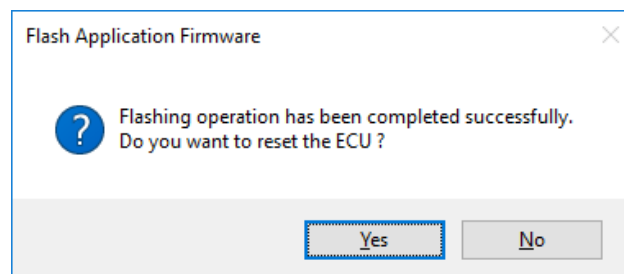

Note: If at any time during the upload the process is interrupted, the data is corrupted (bad checksum) or for any other reason the new firmware is not correct, i.e. bootloader detects that the file loaded was not designed to run on the hardware platform, the bad or corrupted application will not run. Rather, when the ECU is reset or power-cycled the **J1939 Bootloader** will continue to be the default application until valid firmware has been successfully uploaded into the unit.

APPENDIX A - TECHNICAL SPECIFICATION

Technical Specifications:

Specifications are indicative and subject to change. Actual performance will vary depending on the application and operating conditions. Users should satisfy themselves that the product is suitable for use in the intended application. All our products carry a limited warranty against defects in material and workmanship. Please refer to our Warranty, Application Approvals/Limitations and Return Materials Process as described on www.axiomatic.com/service.html.

Input Specifications

Power Supply Input - Nominal	12V, 24V or 48Vdc nominal; 8...60 Vdc
Surge Protection	Provided
Overcurrent Protection	Provided up to 75A
Under-voltage Protection	Built-in
Isolation	All inputs are isolated from the power supply driving the motor and current outputs.
Command Inputs	5 isolated user selectable signal inputs (2 universal signal, 3 digital signal) Refer to Table 1.0. Any input on the controller can be coded into a Proprietary B message that can be sent to the CAN network.
Ground	1 Universal Input Ground
+5V Reference	1 +5V, 100mA, +/-2% Reference Voltage Output

Table 1.0 Inputs to AX102100 (Up to 5 user selectable inputs)	
Input Type	Description
Universal Signal Inputs	<p>Up to 2 universal signal inputs are available. 12-bit Analog to Digital Protected against shorts to GND or +V supply</p> <p>User selectable as: Voltage, Current, PWM or Digital types</p> <p>Voltage: 0...5VDC or 0...10VDC 1 mV resolution, accuracy +/- 1% error</p> <p>Current: 4...20mA or 0...20mA 1 μA resolution, accuracy +/- 1% error Current sense resistor 124Ω</p> <p>PWM Signal Frequency: 1 – 20,000 Hz PWM Duty Cycle: 0 to 100% 0.01% resolution, accuracy +/- 1% error</p> <p>Digital Input: Active High to Vsupply or Active Low to GND Amplitude: 3.3V to +Vsupply</p>
Digital Inputs	<p>Up to 3 fully isolated digital inputs are available. Two inputs are dedicated as STO (Safe Torque Off) or E-Brake safety interlock inputs. Opto-isolated input is normally not active for safety reasons. A power connection is provided which will accept 9...36Vdc from an external power supply or from the battery. If this cable is disconnected, the MOTOR remains OFF.</p> <p>Amplitude: minimum 9 Vdc to maximum 36 Vdc Input current maximum is 8 mA.</p> <p>These inputs can be used as an enable or direction command for the controller. The input accepted is active high (switch is connected to a +V signal when ON).</p>

Output Specifications

Output to Motor	<p>1 fully isolated output for a DC motor Full H-bridge for forward and reverse motor or brake operation 50A @ 24VDC nominal for 2 minutes at room temperature 40A @ 24VDC nominal for 1 hour minimum</p> <p>Overcurrent protection is provided. Short circuit protection is provided.</p> <p>Current measurement is provided. Overcurrent protection is provided @ +/- 75A for each output leg. Supply voltage measurement is provided.</p> <p>The maximum rated speed and motor rated current are configurable to suit individual motor specifications.</p>
Motor Stop	Shut off with or without ramping
Motor Direction	Motor direction command can be mapped to any input or come from the CAN bus.
Motor Control Mode	<p>Flexible control is provided by user configurable parameters for open loop speed control or closed loop speed control using external speed feedback signal, from CAN message or one of the inputs.</p> <p>The control input to drive the motor can be mapped to either of the 5 inputs or the controller can respond to messages from a CAN bus.</p>
Thermal Protection	Thermal protection is built-in and configurable.
Universal Outputs	<p>2 outputs to drive solenoids or other devices User configurable as: Proportional Current (0...2.5A), Hotshot Digital (2.5A), PWM Duty Cycle, Proportional Voltage or On/Off Digital (2.5A)</p> <p>High side sourcing up to 2.5A High frequency drive Overcurrent protection Short circuit protection Ramp and dither setpoints are configurable.</p> <p>Current outputs: 1 mA resolution, accuracy +/- 1% error Voltage outputs: 0.1 V resolution, accuracy +/- 5% error PWM outputs: 0.1% resolution, accuracy +/- 0.1% error Digital outputs: sourcing from power supply or output off Load at supply voltage must not draw more than 2.5A.</p> <p>Hot Shot Coil Saver Outputs (Refer to Figure 2.): The outputs are on/off with a hotshot current which keeps the load ON with a holding current. This is used as an energy saving method of load control.</p> <p>Each output is configurable to send a feedback message to the CAN bus. The feedback is always sent as a word with a resolution of 1 mA/bit, and 0 mA offset.</p>

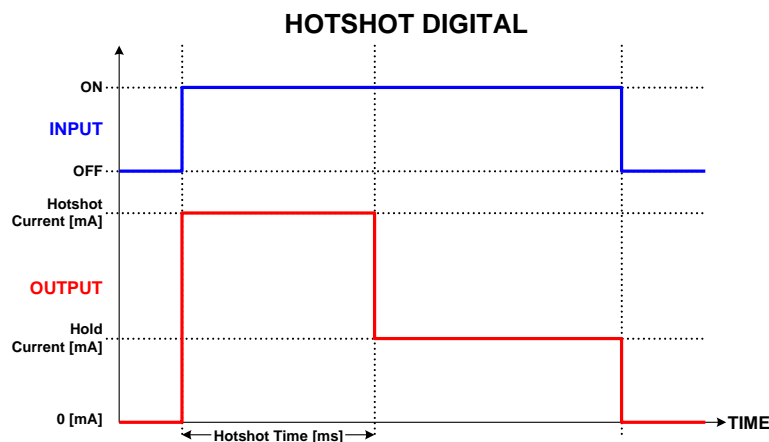

Figure 2 – Proportional Output Hotshot Digital Profile

General Specifications

Microprocessor	STM32F405RGT7
Motor Control	<p>Standard embedded software is provided. The following parameters are user configurable.</p> <p>Motor Direction: Unidirectional or bi-directional control from an input or the CAN bus. The direction is also configurable.</p> <p>Enable: A universal input can be configured to enable the motor when on. A CAN message can also be used as an enable input.</p> <p>Control Mode: Open loop speed or closed loop speed control from an input or CAN message and open loop or closed loop current (torque) control using a fixed limit.</p> <p>CAN: CAN bus messages control the motor and/or auxiliary outputs instead of the analog or digital inputs</p>
CAN User Interface	<p>Electronic Assistant for <i>Windows</i> operating systems It comes with a royalty-free license for use.</p> <p>The Axiomatic Electronic Assistant requires an USB-CAN converter to link the device's CAN port to a <i>Windows</i>-based PC for initial configuration. Order the EA and Axiomatic USB-CAN as a kit (P/N AX070502), which includes all interconnecting cables.</p>
CAN Interface	<p>1 SAE J1939 (AX102100 models) 1 CANopen (AX102101 model)</p>
Baud Rates	Model AX102100: auto-baud rate, default: 250 kbps
Electrical Connections	<p>Refer to Table 2.0. Wires should be of the appropriate gauge to meet requirements of applicable electrical codes and suit the specifications of the connector(s).</p>

Mounting	<p>The motor controller should be mounted as close to the battery and/or the motor as possible. Install the unit with appropriate space available for servicing and for adequate wire harness access and strain relief.</p> <p>Mounting ledges include holes sized for M6 or ¼ inch bolts. The bolt length will be determined by the end-user's mounting plate thickness. Typically, 20 mm (3/4 inch) is adequate.</p>
Shielding & Grounding	Refer to the User Manual.
Enclosure and Dimensions	<p>Encapsulated in an anodized cast aluminum enclosure with lid gasket 5.83 x 8.66 x 2.49 inches 148.00 x 220.00 x 63.25 mm (W x L x H including connectors, excluding mating connectors) <i>Refer to Figure 3.0.</i></p>

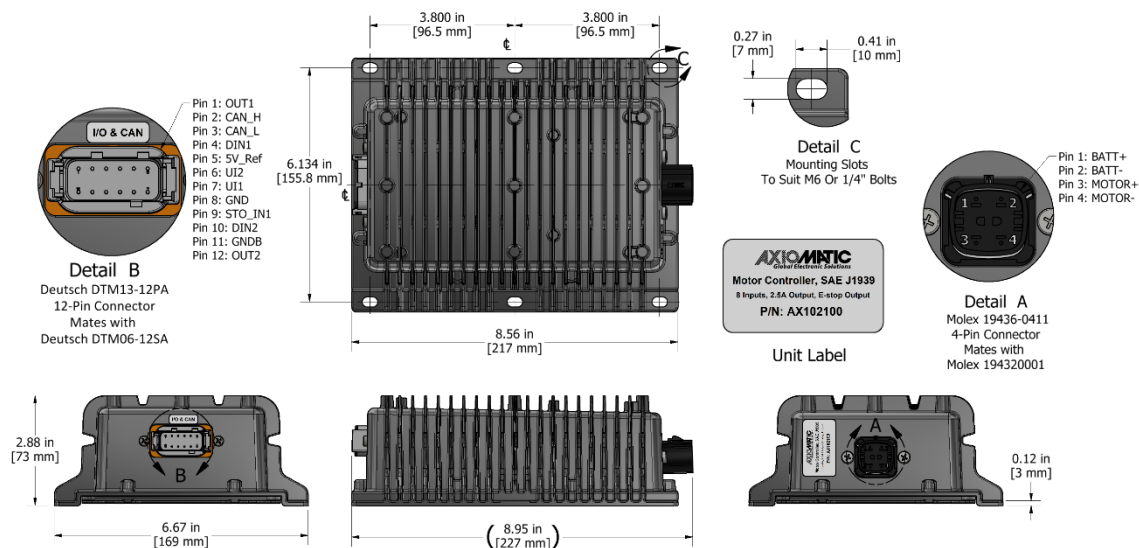

Figure 3 - Dimensional Drawing

Weight	3.35 lb. (1.52 kg) preliminary
Operating Conditions	Operating: -40 to 85°C (-40 to 185°F)
Protection Rating	IP67

Table 2.0 - Electrical Pin Out Chart

<p><u>Input, Output & CAN Connector:</u> TE Deutsch DTM13-12PA Pin 1: Universal Output 1 (Brake Output) Pin 2: CAN_H Pin 3: CAN_L Pin 4: Digital Input 1 Pin 5: +5V Reference Pin 6: Universal Input 2 Pin 7: Universal Input 1 Pin 8: Signal GND Pin 9: STO Input (Digital Input 3) Pin 10: Digital Input 2 Pin 11: Power GND Pin 12: Universal Output 2</p>	<p><u>Mating Connector:</u> PL-DTM06-12SA</p>															
<p><u>Power & Motor Connector:</u> 4 pin Molex P/N: 19436-0411 Pin 1: Battery + Pin 2: Battery - Pin 3: Motor + Pin 4: Motor -</p>	<p><u>Mating Connector:</u> A mating wire harness is available and includes 2 meters (6.5 ft.) of unterminated 12 AWG wires as well as the Molex 19432-0001 mating connector. Ordering P/N: AX070137</p> <table border="1" data-bbox="727 877 1235 1022"> <thead> <tr> <th>Pin#</th> <th>Colour</th> <th>Function</th> </tr> </thead> <tbody> <tr> <td>1</td> <td>Red</td> <td>Batt+</td> </tr> <tr> <td>2</td> <td>Black</td> <td>Batt-</td> </tr> <tr> <td>3</td> <td>White/Red</td> <td>Fwd-/Rev+</td> </tr> <tr> <td>4</td> <td>White/Black</td> <td>Fwd+/Rev-</td> </tr> </tbody> </table>	Pin#	Colour	Function	1	Red	Batt+	2	Black	Batt-	3	White/Red	Fwd-/Rev+	4	White/Black	Fwd+/Rev-
Pin#	Colour	Function														
1	Red	Batt+														
2	Black	Batt-														
3	White/Red	Fwd-/Rev+														
4	White/Black	Fwd+/Rev-														

Specifications are indicative and subject to change. Actual performance will vary depending on the application and operating conditions. Users should satisfy themselves that the product is suitable for use in the intended application. All our products carry a limited warranty against defects in material and workmanship. Please refer to our Warranty, Application Approvals/Limitations and Return Materials Process as described on www.axiomatic.com/service.html.

OUR PRODUCTS

AC/DC Power Supplies
Actuator Controls/Interfaces
Automotive Ethernet Converters
Battery Chargers
CAN Controls, Routers, Repeaters
CAN/WiFi, CAN/Bluetooth
Current/Voltage Converters
DC/DC Power Converters
Engine Temperature Scanners
Ethernet/CAN Converters,
Gateways, Switches
Fan Drive Controllers
Gateways, CAN/Modbus Protocols
Gyroscope Inclinometers
Hydraulic Valve Controllers
Inclinometers, Triaxial
I/O Controls
LVDT Signal Converters
Machine Controls
Modbus Controls
Motor Controls
Power Supplies, DC/DC, AC/DC
PWM Signal Converters/Isolators
Resolver Signal Conditioners
Service Tools
Signal Conditioners, Converters
Strain Gauge CAN Controls
Surge Suppressors

OUR COMPANY

Axiomatic provides electronic machine control components to the off-highway, commercial vehicle, electric vehicle, power generator set, material handling, renewable energy and industrial OEM markets. ***We innovate with engineered and off-the-shelf machine controls that add value for our customers.***

QUALITY DESIGN AND MANUFACTURING

Axiomatic in Canada has an ISO 9001:2015 design and manufacturing facility.

SERVICE

All products to be returned to Axiomatic require a Return Materials Authorization Number (RMA#) from sales@axiomatic.com. Please provide the following information when requesting an RMA number:

- Serial number, part number
- Hours of operation, description of problem
- Wiring set up diagram, application and other comments as needed

SAFE USE

All products should be serviced by Axiomatic. Do not open the product and perform the service yourself.



This product can expose you to chemicals which are known in the State of California, USA to cause cancer and reproductive harm. For more information go to www.P65Warnings.ca.gov.

DISPOSAL

Axiomatic products are electronic waste. Please follow your local environmental waste and recycling laws, regulations and policies for safe disposal or recycling of electronic waste.

WARRANTY, APPLICATION APPROVALS/LIMITATIONS

Axiomatic Technologies Corporation reserves the right to make corrections, modifications, enhancements, improvements, and other changes to its products and services at any time and to discontinue any product or service without notice. Customers should obtain the latest relevant information before placing orders and should verify that such information is current and complete. Users should satisfy themselves that the product is suitable for use in the intended application. All our products carry a limited warranty against defects in material and workmanship. Please refer to our Warranty, Application Approvals/Limitations and Return Materials Process as described on www.axiomatic.com/service.html.

CONTACTS

Axiomatic Technologies Corporation
5915 Wallace Street
Mississauga, ON
CANADA L4Z 1Z8
TEL: +1 905 602 9270
FAX: +1 905 602 9279
www.axiomatic.com
sales@axiomatic.com

Axiomatic Technologies Oy
Höytämöntie 6
33880 Lempäälä
FINLAND
TEL: +358 103 375 750
FAX: +358 3 3595 660
www.axiomatic.com
salesfinland@axiomatic.com