



**USER MANUAL UMAX130700**  
**USER MANUAL UMAX130700-04**

# **CAN to PWM SIGNAL CONVERTER**

## **USER MANUAL**

**P/N: AX130700 Standard**

**P/N: AX130700-04 Custom**

## VERSION HISTORY

<b>Version</b>	<b>Date</b>	<b>Author</b>	<b>Modification</b>
1.0.0.	Apr 10, 2015	Ilona Korpelainen	Initial Draft
1.0.1	May 22, 2015	Amanda Wilkins	Updated technical spec to include a user selectable digital output. Added quiescent current.
1.0.2	May 28, 2015	Amanda Wilkins	Updated pin out.
--	July 3, 2015	Amanda Wilkins	Added response time.
--	August 21, 2015	Amanda Wilkins	Added EA version
--	August 27, 2015	Amanda Wilkins	Added vibration compliance
1.0.4	August 31, 2015	Ilona Korpelainen	Hardware rev2 update
1.0.5	September 10, 2015	Ilona Korpelainen	Added AX130700-04 P/N
1.0.6	December 12, 2016	Ilona Korpelainen	Output setpoint defaults updated (Firmware v2.01)
1.0.7	May 2, 2017	Antti Keränen	11bit CAN Rx & Tx functionality and high CAN baud rate versions added.
2.0.0	August 18, 2022	Gustavo Del Valle	Removed P/N AX130700-01 and AX130700-02 following the addition of autobaud rate support

## ACCRONYMS

ACK	Positive Acknowledgement (from SAE J1939 standard)
BATT +/-	Battery positive (a.k.a. Vps) or Battery Negative (a.k.a. GND)
DIN	Digital Input used to measure active high or low signals
DM	Diagnostic Message (from SAE J1939 standard)
DTC	Diagnostic Trouble Code (from SAE J1939 standard)
EA	Electronic Assistant <sup>®</sup> , p/n AX070502 (A Service Tool for Axiomatic ECUs)
ECU	Electronic Control Unit (from SAE J1939 standard)
GND	Ground reference (a.k.a. BATT-)
I/O	Inputs and Outputs
MAP	Memory Access Protocol
NAK	Negative Acknowledgement (from SAE J1939 standard)
PDU1	A format for messages that are to be sent to a destination address, either specific or global (from SAE J1939 standard)
PDU2	A format used to send information that has been labeled using the Group Extension technique, and does not contain a destination address.
PGN	Parameter Group Number (from SAE J1939 standard)
PropA	Message that uses the Proprietary A PGN for peer-to-peer communication
PropB	Message that uses a Proprietary B PGN for broadcast communication
PWM	Pulse Width Modulation
RPM	Rotations per Minute
SPN	Suspect Parameter Number (from SAE J1939 standard)
TP	Transport Protocol
UIN	Universal input used to measure voltage, current, frequency or digital inputs
Vps	Voltage Power Supply (a.k.a. BATT+)
%dc	Percent Duty Cycle (Measured from a PWM input)

## TABLE OF CONTENTS

<b>1. OVERVIEW OF CONTROLLER</b> .....	<b>7</b>
1.1. Output Function Block .....	8
1.2. Diagnostic Function Blocks .....	11
1.3. CAN Transmit Message Function Block.....	14
1.3.1. CAN Transmit Message Setpoints .....	14
1.3.2. CAN Transmit Signal Setpoints .....	14
1.4. CAN Receive Function Block .....	15
1.5. Available Control Sources .....	16
<b>2. OVERVIEW OF J1939 FEATURES</b> .....	<b>17</b>
2.1. Introduction to Supported Messages.....	17
2.2. NAME, Address and Identification Information.....	18
<b>3. ECU SETPOINTS ACCESSED WITH ELECTRONIC ASSISTANT</b> .....	<b>21</b>
3.1. J1939 Network Parameters .....	21
3.2. PWM Output Setpoints .....	23
3.3. CAN Transmit Setpoints .....	25
3.4. CAN Receive Setpoints .....	27
3.5. Diagnostic Setpoints .....	28
<b>4. REFLASHING OVER CAN WITH EA BOOTLOADER</b> .....	<b>31</b>
<b>APPENDIX A - TECHNICAL SPECIFICATION</b> .....	<b>A-1</b>

Table 1 – Output Type Options .....	8
Table 2 – Digital Response Options .....	9
Table 3 – Delay Polarity .....	9
Table 4 – Enable Response Options .....	10
Table 5 – Override Response Options .....	10
Table 6 – Fault Response Options .....	10
Table 7 – Fault Detect Thresholds .....	11
Table 8 – Diagnostic Lamp Type Options .....	12
Table 9 – FMI for Event Used in DTC Options .....	13
Table 10 – Low Fault FMIs and corresponding High Fault FMIs .....	13
Table 11 – Available Control Sources and Numbers .....	16
Table 12 – J1939 Network Setpoints.....	22
Table 13 – Output type ranges .....	23
Table 14 –Output Setpoints.....	24
Table 15 – CAN Transmit Message Setpoints .....	26
Table 16 – CAN Receive Setpoints.....	27
Table 17 – Power Supply Diagnostic Setpoints .....	29
Table 18 – Over Temperature Diagnostic Setpoints .....	30
Table 19 – Lost Communication Diagnostic Setpoints.....	30
Figure 1 – Hardware Functional Block Diagram.....	7
Figure 2 - Analog source to Digital input .....	16
Figure 3 - General ECU Information.....	19
Figure 4 - Screen Capture of J1939 Setpoints .....	22
Figure 5 - Screen Capture of Universal Output Setpoints.....	23
Figure 6 - Screen Capture of CAN Transmit Message Setpoints .....	25
Figure 7 - Screen Capture of CAN Receive Message Setpoints .....	27
Figure 8 - Screen Capture of Power Supply Diagnostic Setpoints.....	28
Figure 9 - Screen Capture of Over Temperature Diagnostic Setpoints .....	29
Figure 10 - Screen Capture of Lost Communication Diagnostic Setpoints .....	30

## REFERENCES

J1939	Recommended Practice for a Serial Control and Communications Vehicle Network, SAE, April 2011
J1939/21	Data Link Layer, SAE, December 2010
J1939/71	Vehicle Application Layer, SAE, March 2011
J1939/73	Application Layer-Diagnostics, SAE, February 2010
J1939/81	Network Management, SAE, May 2003
TDAX130700	Technical Datasheet, CAN to PWM Signal Converter, Axiomatic Technologies 2015
UMAX07050x	User Manual V4.10.77, Electronic Assistant and USB-CAN, Axiomatic Technologies, May 2015

***This document assumes the reader is familiar with the SAE J1939 standard. Terminology from the standard is used, but not described in this document.***



NOTE: This product is supported by Electronic Assistant® V4.10.77.0 and higher.

## 1. OVERVIEW OF CONTROLLER

The CAN to PWM Signal Converter (CAN-1PWM) is designed for converting CAN messages into PWM signals to communicate with legacy Engine Control Modules.

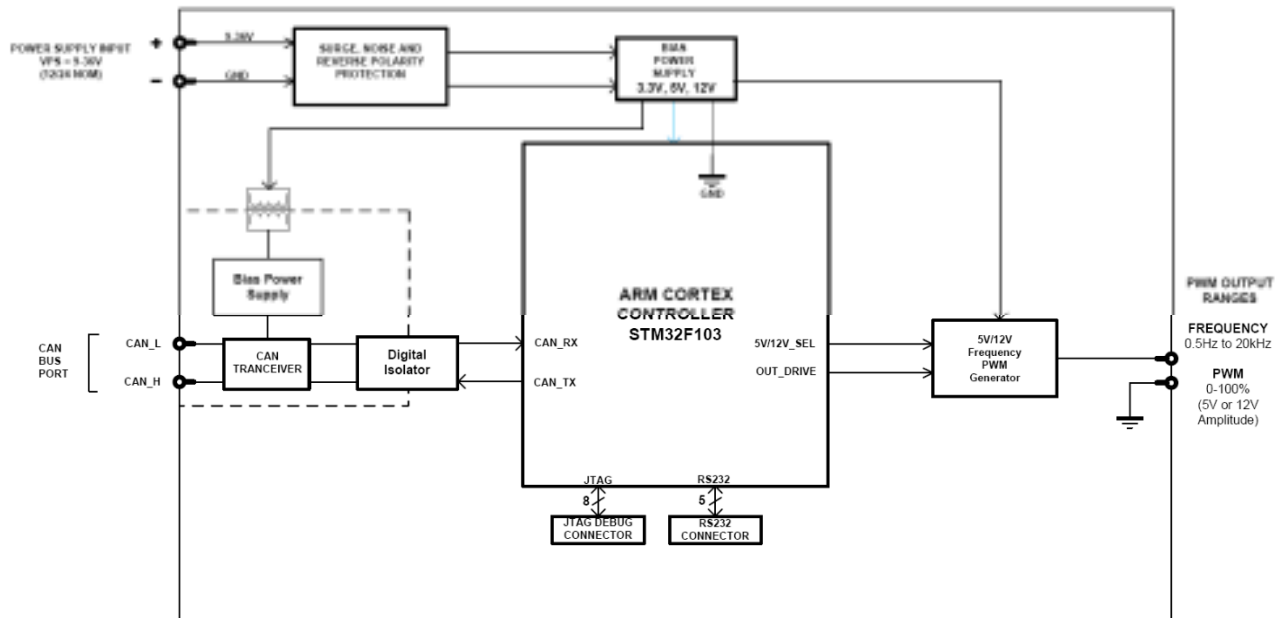

Figure 1 – Hardware Functional Block Diagram

The controller has a CAN port to receive and transmit CAN messages. The output is a pulse width modulated signal with user selectable amplitude. The output can be programmed to produce pulse width modulated signal with fixed frequency, frequency modulated signal with fixed pulse width, digital On/Off signal or pulse width and frequency modulated signal (mixed mode).

The Axiomatic Electronic Assistant<sup>®</sup> is used to configure the CAN-1PWM Controller. Configurable properties, EA setpoints, are listed in chapter 3. A setpoint configuration can be saved in a file which can then be utilized to program the same configuration to another Dual Input Dual Output Signal Controller. Throughout this document EA setpoint names are referred with bolded text in double-quotes and the setpoint option is referred with italicized text in single-quotes. For example “**Output amplitude**” setpoint set to option ‘*0 to 5V*’.

In this document the configurable properties of the ECU are divided into function blocks, namely Output Function Block, CAN Transmit Message Function Block, CAN Receive Message Function Block, Diagnostic Function Block. These function blocks are presented in detail in next subchapters.

The CAN to PWM Signal Converter can be ordered using the following part numbers depending on the application.

AX130700	Standard firmware with the J1939 autobaud rate support (default 250kbts/s).
AX130700-04	Custom firmware, that does not fully comply with J1939 standard (see section 1.4)

### 1.1. Output Function Block

The controller has a single PWM Output. A timer peripheral of the controller produces the output signal. Output signal frequency range is from 1 Hz to 20 kHz and duty cycle range from 0% to 100%. “**Output Type**” setpoint determines what kind of signal the output produces. Changing this setpoint causes other setpoints in the group to update to match selected type, thus the “**Output Type**” should be selected before configuring other setpoints within the setpoint group. “**Output Type**” setpoint options are listed in Table 1.

0	<i>Disabled</i>
40	<i>Frequency 0 to 20kHz</i>
50	<i>PWM</i>
60	<i>Digital On/Off</i>
70	<i>Mixed PWM and Frequency</i>

**Table 1 – Output Type Options**

With ‘*Frequency 0 to 50Hz*’ output type and frequency with ‘*PWM*’ output type, “**Fixed Output Frequency/PWM Duty Cycle**” setpoint is used to select fixed output frequency or fixed duty cycle. The value of this setpoint defaults when “**Output Type**” setpoint is changed. The Frequency PWM Generator generates output signal with either 5V or 12V amplitude. The output amplitude is selected with “**Output Amplitude**” setpoint.

The output signal minimum and maximum values are configured with “**Output At Minimum Command**” and “**Output At Maximum Command**” setpoints. The unit of these values depends on selected “**Output Type**”.

With linear output types (all output types except ‘*Digital On/Off*’), regardless of what type of control input is selected, the output will always respond in a linear fashion to changes in the input per Equation 1.

$$y = mx + a$$

$$m = \frac{Y_{max} - Y_{min}}{X_{max} - X_{min}}$$

$$a = Y_{min} - m * X_{min}$$

#### Equation 1 - Linear Slope Calculations

In the case of the Output Control Logic function block, X and Y are defined as

Xmin = Control Input Minimum    Ymin = “**Output at Minimum Command**”

Xmax = Control Input Maximum    Ymax = **“Output at Maximum Command”**

In all cases, while X-axis has the constraint that Xmin < Xmax, there is no such limitation on the Y-axis. Thus configuring **“Output At Minimum Command”** to be greater than **“Output At Maximum Command”** allows output to follow control signal inversely.

In order to prevent abrupt changes at the output due to sudden changes in the command input, the user can choose to use the independent up or down ramps to smooth out the response. The **“Ramp Up”** and **“Ramp Down”** setpoints are in milliseconds, and the step size of the output change will be determined by taking the absolute value of the output range and dividing it by the ramp time.

With the *‘Digital On/Off’* output type, in OFF state output is 0V and in ON state 5V or 12V depending on selected amplitude. The *‘Digital On/Off’* output type has several associated setpoints. The **“Digital Response”** setpoint is used to select digital response, setpoint options are listed in Table 2.

0	<i>Normal On/Off</i>
1	<i>Inverse Logic</i>
2	<i>Latched Logic</i>
3	<i>Blinking Logic</i>

**Table 2 – Digital Response Options**

In a *‘Normal’* response, when the Control input commands the output ON, then the output will be turned ON. However, in an *‘Inverse’* response, the output will be ON unless the input commands the output ON, in which case it turns OFF.

The **“Digital Out Delay”** and **“Delay Polarity”** setpoints are associated with *‘Normal’* **“Digital Response”**. The **“Digital Out Delay”** defines output state change delay in milliseconds. Setting **“Digital Out Delay”** to 0ms applies no state change delay. The **“Delay Polarity”** setpoint defines which edge the state change delay will be applied. For example, selecting *‘Rising Edge’* for **“Delay Polarity”** and setting **“Digital Out Delay”** value >0ms, applies defined delay when driving output signal state changes from OFF to ON.

0	<i>Rising Edge</i>
1	<i>Falling Edge</i>

**Table 3 – Delay Polarity**

If a *‘Latched’* response is selected, the output will change state, when the input commands the state from OFF to ON.

If a *‘Blinking’* response is selected, the output will blink at the rate of the **“Digital Blink Rate”** setpoint while the input commands the output ON. When commanded OFF, the output will stay off.

The **“Control Source”** setpoint together with **“Control Number”** setpoint determine which signal is used to control the output. The available control sources for the output are Received CAN Messages from 1 to 4. The selected signal is scaled per Control Input Minimum (**“Receive Data Min”**) and Control Input Maximum (**“Receive Data Max”**) between 0 and 1 to form the control signal. If a non-digital signal is selected to drive digital output the command state will be 0 (OFF) at or below the **“Output At Minimum Command”**, 1 (ON) at or above **“Output At Maximum Command”** and will not change in between those points.

With the ‘*Mixed PWM and Frequency*’ output type, output control signal controls duty cycle of the output. With this output type duty cycle is considered as main variable, thus associated setpoints are interpreted in percentages. Frequency control signal is selected with with “**Frequency Control Source**” and “**Frequency Control Number**” setpoints. Associated “**Mixed Output Frequency Min**” and “**Mixed Output Frequency Max**” setpoints determine minimum and maximum values of the frequency control signal.

In addition to the Control input, outputs also support Enable and Override inputs.

The “**Enable Source**” setpoint together with “**Enable Number**” setpoint determine the enable signal for the output in question. The “**Enable Response**” setpoint is used to select how output will respond to the selected Enable signal. “**Enable Response**” setpoint options for the PWM output are listed in Table 4. If “**Enable Source**” is set to ‘*Control not used*’, the Enable signal is interpreted to be ON. If a non-digital signal is selected as Enable signal the signal is interpreted as shown in Figure 2.

0	<i>Enable When On, Else Shutoff</i>
1	<i>Enable When On, Else Rampoff</i>
2	<i>Enable When Off, Else Shutoff</i>
3	<i>Enable When Off, Else Rampoff</i>
4	<i>Enable When On, Else Ramp To Min</i>
5	<i>Enable When On, Else Ramp To Max</i>

**Table 4 – Enable Response Options**

Override input allows the output drive to be configured to go to a default value in the case of the override input being engaged/disengaged, depending on the logic selected in “**Override Response**”, presented on Table 5. When active, the output will be driven to the value in “**Output at Override Command**” regardless of the value of the Control input. The “**Override Source**” and “**Override Number**” together determine the Override input signal.

0	<i>Override When On</i>
1	<i>Override When Off</i>

**Table 5 – Override Response Options**

If a fault (i.e. CAN Receive Timeout, see section 1.4) is detected in any of the active inputs (Control/Enable/Override) the output will respond per “**Control Fault Response**” setpoint as outlined in Table 6. Fault Value is defined by “**Output in Fault Mode**” setpoint value, which is interpreted in selected output units.

0	<i>Shutoff Output</i>
1	<i>Apply Fault Value</i>
2	<i>Hold Last Value</i>

**Table 6 – Fault Response Options**

Another fault response that can be enabled is that a power supply over voltage or under voltage will automatically disable the output. Note: this setpoint is associated with the **Power Supply Diag** function block. Also, if the **Over Temperature Diag** function block is enabled, then a microprocessor over-temperature reading disables all the outputs until it has cooled back to the operating range.

The Output has a feedback connection, which is associated with output diagnostic. The feedback is an internal frequency input, which is monitored according to selected “**Output Type**”. With the ‘*Mixed*

*PWM and Frequency*’ output type, duty cycle of the feedback signal is the monitored variable. Fault detection and associated setpoints are presented in section 1.2.

## 1.2. Diagnostic Function Blocks

The CAN-1PWM controller supports diagnostic messaging. DM1 message is a message, containing Active Diagnostic Trouble Codes (DTC) that is sent to the J1939 network in case a fault has been detected. A Diagnostic Trouble Code is defined by the J1939 standard as a four byte value which is a combination of:

SPN	Suspect Parameter Number	(user defined)
FMI	Failure Mode Identifier	(see Table 9 and Table 10)
CM	Conversion Method	(always set to 0)
OC	Occurrence Count	(number of times the fault has happened)

In addition to supporting the DM1 message, CAN-1PWM also supports:

DM2	Previously Active Diagnostic Trouble Codes	Sent only on request
DM3	Diagnostic Data Clear/Reset of Previously Active DTCs	Done only on request
DM11	Diagnostic Data Clear/Reset for Active DTCs	Done only on request

The CAN-1PWM can detect/react to four faults namely power supply fault, over temperature fault, communication fault and output fault. Output error diagnostic setpoints are presented in output setpoint group and each of other fault is presented in EA as an individual setpoint group.

Fault detection thresholds are presented in Table 7. Power Supply fault can be flagged as either a high or low occurrence and has two selectable threshold setpoints. Over Temperature fault reacts only to a single condition and thus, the only one threshold setpoint is supplied. Lost Communication fault occurs if no CAN messages are received within “**Receive Message Timeout**” time (see section 1.4). The PWM output can be selected to disable in a case of a power supply and/or temperature error, by setting “**Power Fault Disables Outputs**” and/or “**Over Temperature Shutdown**” setpoint value to ‘True’.

A hysteresis can be applied to prevent rapid setting and clearing of the error flag when signal value is near the fault detection threshold, by configuring “**Hysteresis to clear fault**” setpoint.

Output fault is monitored from measured feedback signal. The measured feedback value is compared with desired output target value and if the difference between the two is greater than “**Hysteresis to Clear Fault**” setpoint value, an error will be flagged.

Fault	Minimum Threshold	Maximum Threshold
Output	Target - Hysteresis to Clear Fault	Target + Hysteresis to Clear Fault
Power Supply	Power Undervoltage Threshold	Power Overvoltage Threshold
Over Temperature	N/A	Over Temperature Threshold
Lost Communication	N/A	Received Message Timeout

**Table 7 – Fault Detect Thresholds**

“**Generate Diagnostic Messages**” setpoint determines whether an active fault generates diagnostic trouble code (DTC) that is sent to J1939 network as part of diagnostic message (DM). So long as

even one Diagnostic function block has “**Generate Diagnostic Messages**” set to ‘*True*’, the CAN-1PWM Controller will send the DM1 message every one second, regardless of whether or not there are any active faults, as recommended by standard. While there are no active DTCs, the CAN-1PWM Controller will send “No Active Faults” message. If a previously inactive DTC becomes active, a DM1 will be sent immediately to reflect this. As soon as the last active DTC goes inactive, a DM1 indicating that there are no more active DTCs will be sent.

If there is more than one active DTC at any given time, the regular DM1 message will be sent using a multipacket message to the Requester Address using the Transport Protocol (TP).



At power up, the DM1 message will not be broadcasted until after 5 second delay. This is done to prevent any power up or initialization conditions from being flagged as an active error on the network.

When the fault is linked to a DTC, a non-volatile log of the occurrence count (OC) is kept. As soon as the controller detects a new (previously inactive) fault, it will start decrementing the “**Delay Before Sending DM1**” timer for that Diagnostic function block. If the fault has remained present during the delay time, then the controller will set the DTC to active, and will increment the OC in the log. A DM1 will immediately be generated that includes the new DTC. The timer is provided so that intermittent faults do not overwhelm the network as the fault comes and goes, since a DM1 message would be sent every time the fault shows up or goes away.

By default, the fault flag is cleared when error condition that has caused it goes away. The DTC is made Previously Active and is it is no longer included in the DM1 message. To identify a fault having happened, even if the condition that has caused is one away, the “**Event Cleared only by DM11**” setpoint can be set to ‘*True*’. This configuration enables DTC to stay Active, even after the fault flag has been cleared, and be included in DM1 message until a “**Diagnostic Data Clear/Reset for Active DTCs**” (DM11) has been requested.

As defined by J1939 Standard the first byte of the DM1 message reflects the Lamp status. “**Diagnostic Lamp Type**” setpoint determines the lamp type set in this byte of DTC. “**Diagnostic Lamp Type**” setpoint options are listed in Table 8. By default, the ‘*Amber, Warning*’ lamp is typically the one set for any active fault.

0	<i>Protect</i>
1	<i>Amber Warning</i>
2	<i>Red Stop</i>
3	<i>Malfunction</i>

**Table 8 – Diagnostic Lamp Type Options**

The “**SPN for Event used in DTC**” setpoint defines suspect parameter number used as part of DTC. **It is user’s responsibility to select an SPN that will not violate J1939 standard.** When the “**SPN for Event used in DTC**” is changed, the OC of the associated error log is automatically reset to zero.

0	<i>Data Valid But Above Normal Operational Range - Most Severe Level</i>
1	<i>Data Valid But Below Normal Operational Range - Most Severe Level</i>
2	<i>Data Intermittent</i>
3	<i>Voltage Above Normal, Or Shorted To High Source</i>
4	<i>Voltage Below Normal, Or Shorted To Low Source</i>
5	<i>Current Below Normal Or Open Circuit</i>
6	<i>Current Above Normal Or Grounded Circuit</i>
7	<i>Mechanical Error</i>
8	<i>Abnormal Frequency Or Pulse Width Or Period</i>
9	<i>Abnormal Update Rate</i>
10	<i>Abnormal Rate Of Change</i>
11	<i>Root Cause Not Known</i>
12	<i>Bad Component</i>
13	<i>Out Of Calibration</i>
14	<i>Special Instructions</i>
15	<i>Data Valid But Above Normal Operating Range – Least Severe Level</i>
16	<i>Data Valid But Above Normal Operating Range – Moderately Severe Level</i>
17	<i>Data Valid But Below Normal Operating Range – Least Severe Level</i>
18	<i>Data Valid But Below Normal Operating Range – Moderately Severe Level</i>
19	<i>Network Error</i>
20	<i>Data Drifted High</i>
21	<i>Data Drifted Low</i>
31	<i>Condition Exists</i>

**Table 9 – FMI for Event Used in DTC Options**

Every fault has associated a default FMI with them. The used FMI can be configured with “**FMI for Event Used in DTC**” setpoint. When an FMI is selected from Low Fault FMIs in Table 10 for a fault that can be flagged either high or low occurrence, the high occurrence automatically uses corresponding High Fault FMI by Table 10. If any other FMI is selected than the Low Fault FMI from the Table 10, then both the low and high fault will be assigned the same FMI.

Low Fault FMIs	High Fault FMIs
<i>FMI=1, Data Valid But Below Normal Operation Range – Most Severe Level</i>	<i>FMI=0, Data Valid But Above Normal Operational Range – Most Severe Level</i>
<i>FMI=4, Voltage Below Normal, Or Shorted to Low Source</i>	<i>FMI=3, Voltage Above Normal, Or Shorted To High Source</i>
<i>FMI=5, Current Below Normal Or Open Circuit</i>	<i>FMI=6, Current Above Normal Or Grounded Circuit</i>
<i>FMI=17, Data Valid But Below Normal Operating Range – Least Severe Level</i>	<i>FMI=15, Data Valid But Above Normal Operating Range – Least Severe Level</i>
<i>FMI=18, Data Valid But Below Normal Operating Level – Moderately Severe Level</i>	<i>FMI=16, Data Valid But Above Normal Operating Range – Moderately Severe Level</i>
<i>FMI=21, Data Drifted Low</i>	<i>FMI=20, Data Drifted High</i>

**Table 10 – Low Fault FMIs and corresponding High Fault FMIs**

### 1.3. CAN Transmit Message Function Block

The CAN Transmit function block is used to send any output from another function block to the J1939 network. The CAN-1PWM Controller a CAN Transmit Messages which has four completely user defined signals.

#### 1.3.1. CAN Transmit Message Setpoints

The CAN Transmit Message setpoint group includes setpoints that effect the whole message and are thus mutual for all signals of the message. These setpoints are presented in this section. The setpoints that configure an individual signal are presented in next section.

The “**Transmit PGN**” setpoint sets PGN used with the message. **User should be familiar with the SAE J1939 standard, and select values for PGN/SPN combinations as appropriate from section J1939/71.**

The “**Use 11bit ID**” setpoint defines the CAN frame ID field length to use. In case set to ‘*True*’, CAN Transmit messages use 11 bits long ID field. Transmit PGN values in range 0x0 ... 0x7FF are feasible.

“**Repetition Rate**” setpoint defines the interval used to send the message to the J1939 network. If the “**Repetition Rate**” is set to zero, the message is disabled.



At power up, transmitted message will not be broadcasted until after a 5 second delay. This is done to prevent any power up or initialization conditions from creating problems on the network.

By default, messages are sent on Proprietary B PGNs as broadcast messages. Thus “**Transmit Message Priority**” is always initialized to 6 (low priority) and the “**Destination Address**” setpoint is not used. This setpoint is only valid when a PDU1 PGN has been selected, and it can be set either to the Global Address (0xFF) for broadcasts, or sent to a specific address as setup by the user.

#### 1.3.2. CAN Transmit Signal Setpoints

Each CAN transmit message has four associated signals, which define data inside the Transmit message. “**Control Source**” setpoint together with “**Control Number**” setpoint define the signal source of the message. “**Control Source**” and “**Control Number**” options are listed in Table 11. Setting “**Control Source**” to ‘*Control Not Used*’ disables the signal.

“**Transmit Data Size**” setpoint determines how many bits signal reserves from the message. “**Transmit Data Index in Array**” determines in which of 8 bytes of the CAN message LSB of the signal is located. Similarly “**Transmit Bit Index in Byte**” determines in which of 8 bits of a byte the LSB is located. These setpoints are freely configurable, thus **it is the User’s responsibility to ensure that signals do not overlap and mask each other.**

“**Transmit Data Resolution**” setpoint determines the scaling done on the signal data before it is sent to the bus. “**Transmit Data Offset**” setpoint determines the value that is subtracted from the

signal data before it is scaled. Offset and Resolution are interpreted in units of the selected source signal.

#### 1.4. CAN Receive Function Block

The CAN-1PWM Controller supports up to four unique CAN Receive Messages. A CAN Receive function block is designed to take any SPN from the J1939 network, and use it as an input to another function block (i.e. Output).

The “**Receive Message Enabled**” is the most important setpoint associated with this function block and it should be selected first. Changing it will result in other setpoints being enabled/disabled as appropriate. By default ALL receive messages are disabled.

The “**Receive PGN**” defines parameter group number of the message to be received. The standard firmware (P/N AX130700) follows J1939 Standard by classifying CAN messages to PDU1 and PDU2. AX130700-04 firmware is customized to treat receive PGN 0000 as PDU2, so it can be accepted regardless of the ECU address (see section 3.1).

The “**Use 11bit ID**” setpoint defines the CAN frame ID field length to use. In case set to ‘True’, CAN Receive messages expects to receive messages with 11 bits long ID field. Receive PGN values in range 0x0 ... 0x7FF are feasible.

A non-zero “**Receive Message Timeout**” defines expected message update rate. Once a message has been enabled, if the message is not received off the bus within the “**Receive Message Timeout**” period, the message data is zeroed and CAN Receive Timeout flagged on signal in question (see section 1.1). If enabled, Lost Communication fault will be flagged as well, which could trigger a Lost Communication event as described in section 1.2. In order to avoid timeouts on a heavily saturated network, it is recommended to set the period at least three times longer than the expected update rate. To disable the timeout feature, simply set this value to zero, in which case the received message will never trigger a Lost Communication fault.

By default, all control messages are expected to be sent to the CAN-1PWM Controller on Proprietary B PGNs. However, should a PDU1 message be selected, the 2 Input 2 Output Controller can be setup to receive it from any ECU by setting the “**Specific Address that sends the PGN**” to the Global Address (0xFF). If a specific address is selected instead, then any other ECU data on the PGN will be ignored.

The “**Receive Data Size**”, “**Receive Data Index in Array (LSB)**”, “**Receive Bit Index in Byte (LSB)**”, “**Receive Resolution**” and “**Receive Offset**” can all be used to map any SPN supported by the J1939 standard to the output data of the Received function block.

As mentioned earlier, a CAN receive function block can be selected as the source of the control input for the output function block. When this is case, the “**Received Data Min (Off Threshold)**” and “**Received Data Max (On Threshold)**” setpoints determine the minimum and maximum values of the control signal. As the names imply, they are also used as the On/Off thresholds for digital output types. These values are in whatever units the data is AFTER the resolution and offset is applied to CAN receive signal.

## 1.5. Available Control Sources

Both CAN Transmit Message Function block and Output Function block have selectable “**Control Sources**” and “**Control Numbers**” to select inputs of the block. “**Control Source**” setpoint determines the type of the source and “**Control Number**” selects the actual source if there is more than one of the same type. Available “**Control Source**” options and associated “**Control Number**” ranges are listed in Table 11.

Sources	Number Range	Notes
0: Control Not Used	N/A	When this is selected, it disables all other setpoints associated with the signal in question.
1: Received CAN Message	1 to 4	User must enable the function block, as it is disabled by default.
2: Output Target Value	1 to 2	Can be mapped to a CAN Transmit Message. 1: Output target value 2: In mixed mode Output target frequency
3: Output Feedback	1 to 2	Measured output feedback, used in Output Diagnostics, can be mapped to a CAN Transmit Message. 1: Output feedback value 2: In mixed mode Output frequency feedback
4: Power Supply Measured	N/A	Measured power supply value in Volts, used in Power Supply Diagnostics, can be mapped to a CAN Transmit Message.
5: Processor Temperature Measured	N/A	Measured processor temperature in °C, used in Over Temperature Diagnostics, can be mapped to a CAN Transmit Message.

**Table 11 – Available Control Sources and Numbers**

If a non-digital signal is selected to drive a digital input, the signal is interpreted to be OFF at or below the minimum of selected source and ON at or above the maximum of the selected source, and it will not change in between those points. Thus analog to digital interpretation has a built in hysteresis defined by minimum and maximum of the selected source, as shown in Figure 2.

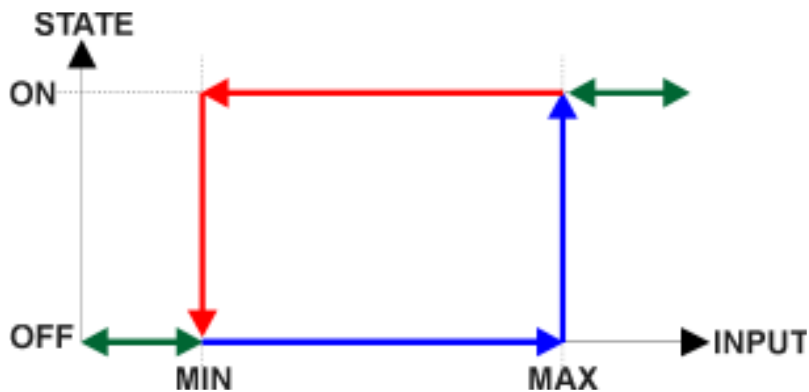

**Figure 2 - Analog source to Digital input**

## 2. OVERVIEW OF J1939 FEATURES

---

The software was designed to provide flexibility to the user with respect to messages sent from the ECU by providing:

- Configurable ECU Instance in the NAME (to allow multiple ECUs on the same network)
- Configurable Input Parameters
- Configurable PGN and Data Parameters
- Configurable Diagnostic Messaging Parameters, as required
- Diagnostic Log, maintained in non-volatile memory

### 2.1. Introduction to Supported Messages

The ECU is compliant with the standard SAE J1939, and supports following PGNs from the standard.

#### From J1939-21 – Data Link Layer

- Request 59904 0x00EA00
- Acknowledgement 59392 0x00E800
- Transport Protocol – Connection Management 60416 0x00EC00
- Transport Protocol – Data Transfer Message 60160 0x00EB00
- Proprietary B from 65280 0x00FF00  
to 65535 0x00FFFF  
to 65535 0x00FFFF

#### From J1939-73 – Diagnostics

- DM1 – Active Diagnostic Trouble Codes 65226 0x00FECA
- DM2 – Previously Active Diagnostic Trouble Codes 65227 0x00FECB
- DM3 – Diagnostic Data Clear/Reset for Previously Active DTCs 65228 0x00FECC
- DM11 – Diagnostic Data Clear/Reset for Active DTCs 65235 0x00FED3
- DM14 – Memory Access Request 55552 0x00D900
- DM15 – Memory Access Response 55296 0x00D800
- DM16 – Binary Data Transfer 55040 0x00D700

#### From J1939-81 – Network Management

- Address Claimed/Cannot Claim 60928 0x00EE00
- Commanded Address 65240 0x00FED8

#### From J1939-71 – Vehicle Application Layer

- ECU Identification Information 64965 0x00FDC5
- Software Identification 65242 0x00FEDA
- Component Identification 65259 0x00FEED

None of the application layer PGNs are supported as part of the default configurations, but they can be selected as desired for transmit function blocks.

Setpoints are accessed using standard Memory Access Protocol (MAP) with proprietary addresses. The Electronic Assistant® (EA) allows for quick and easy configuration of the unit over CAN network.

## 2.2. NAME, Address and Identification Information

The CAN to PWM Signal Converter has the following default for the J1939 NAME. The user should refer to the SAE J1939/81 standard for more information on these parameters and their ranges.

Arbitrary Address Capable	Yes
Industry Group	0, Global
Vehicle System Instance	0
Vehicle System	0, Non-specific system
Function	125, Axiomatic IO Controller
Function Instance	11, Axiomatic AX130700
ECU Instance	0, First Instance
Manufacture Code	162, Axiomatic Technologies
Identity Number	Variable, uniquely assigned during factory programming for each ECU

The ECU Instance is a configurable setpoint associated with the NAME. Changing this value will allow multiple ECUs of this type to be distinguishable from one another when they are connected on the same network.

The default value of the “ECU Address” setpoint is 128 (0x80), which is the preferred starting address for self-configurable ECUs as set by the SAE in J1939 tables B3 and B7. The EA will allow the selection of any address between 0 and 253. ***It is user’s responsibility to select an address that complies with the standard.*** The user must also be aware that since the unit is arbitrary address capable, if another ECU with a higher priority NAME contends for the selected address, the 2In2Out Controller will continue select the next highest address until it finds one that it can claim. See J1939/81 for more details about address claiming.

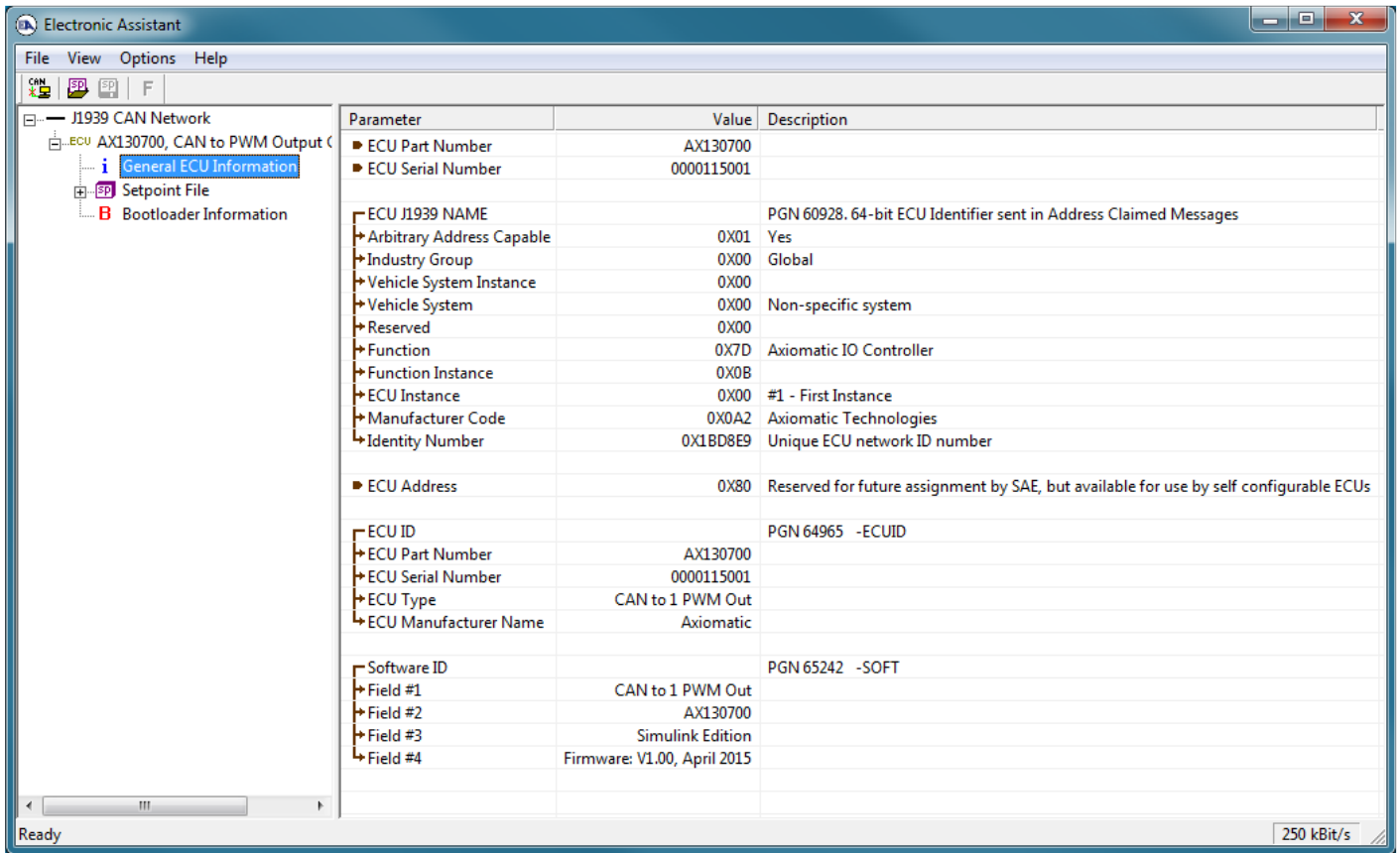

Figure 3 - General ECU Information

## ECU Identification Information

PGN 64965	ECU Identification Information	-ECUID	
Transmission Repetition Rate:	On request		
Data Length:	Variable		
Extended Data Page:	0		
Data Page:	0		
PDU Format:	253		
PDU Specific:	197 PGN Supporting Information:		
Default Priority:	6		
Parameter Group Number:	64965 (0x00FDC5)		
Start Position	Length	Parameter Name	SPN
a	Variable	ECU Part Number, Delimiter (ASCII “*”)	2901
b	Variable	ECU Serial Number, Delimiter (ASCII “*”)	2902
c	Variable	ECU Location, Delimiter (ASCII “*”)	2903
d	Variable	ECU Type, Delimiter (ASCII “*”)	2904
e	Variable	ECU Manufacturer Name, Delimiter (ASCII “*”)	4304
(a)*(b)*(c)*(d)*(e)*			

## Software Identifier

PGN 65242	Software Identification	-SOFT	
Transmission Repetition Rate:	On request		
Data Length:	Variable		
Extended Data Page:	0		
Data Page:	0		
PDU Format:	254		
PDU Specific:	218 PGN Supporting Information:		
Default Priority:	6		
Parameter Group Number:	65242 (0x00FEDA)		
Start Position	Length	Parameter Name	SPN
1	1 Byte	Number of software identification fields	965
2-n	Variable	Software identification(s), Delimiter (ASCII “*”)	234

Byte 1 is set to 5, and the identification fields are as follows.

**(Part Number)\*(Version)\*(Date)\*(Owner)\*(Description)**

The EA shows all this information in “General ECU Information”, as shown in Figure 3.

*Note: The information provided in the Software ID is available for any J1939 service tool which supports the PGN -SOFT*

## Component Identification

PGN 65259	Component Identification	-CI	
Transmission Repetition Rate:	On request		
Data Length:	Variable		
Extended Data Page:	0		
Data Page:	0		
PDU Format:	254		
PDU Specific:	235 PGN Supporting Information:		
Default Priority:	6		
Parameter Group Number:	65259 (0x00FEED)		
Start Position	Length	Parameter Name	SPN
a	1-5 Byte	Make, Delimiter (ASCII “*”)	586
b	Variable	Model, Delimiter (ASCII “*”)	587
c	Variable	Serial Number, Delimiter (ASCII “*”)	588
d	Variable	Unit Number (Power Unit), Delimiter (ASCII “*”)	233
<b>(a)*(b)*(c)*(d)*(e)*</b>			

### 3. ECU SETPOINTS ACCESSED WITH ELECTRONIC ASSISTANT

---

This section describes in detail each setpoint, and their default and ranges. Default values presented in tables are values used when setpoint in question is active. Many of the setpoints are dependent on other setpoints and they may not be active by default. Associated Figures show screen capture of initial operation, however some of the setpoints are not in default condition as they are set differently to activate more setpoints for the image. The setpoints are divided into setpoint groups as they are shown in EA. For more information on how each setpoint is used by CAN to PWM Signal Converter, refer to the relevant section in this user manual.

#### 3.1. Accessing the ECU Using EA

ECU with P/N AX130700 does not need any specific setup for EA. In order to access the high speed versions, the CAN bus Baud Rate needs to be set accordingly. The CAN Interface Setup can be found from “Options” menu in EA.

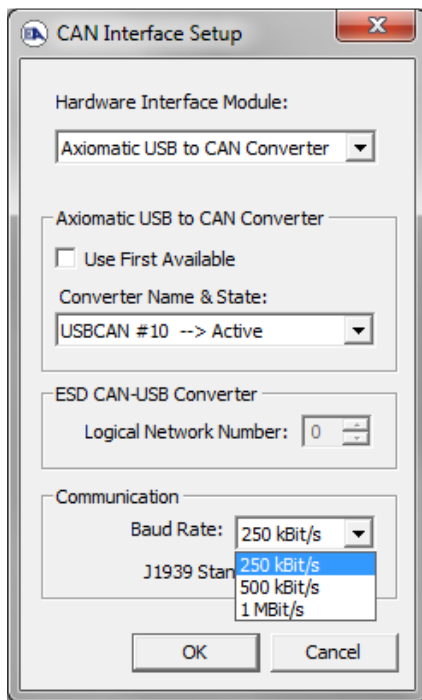

### 3.2. J1939 Network Parameters

“ECU Instance Number” and “ECU Address” setpoints and their effect are defined in Section 2.2.

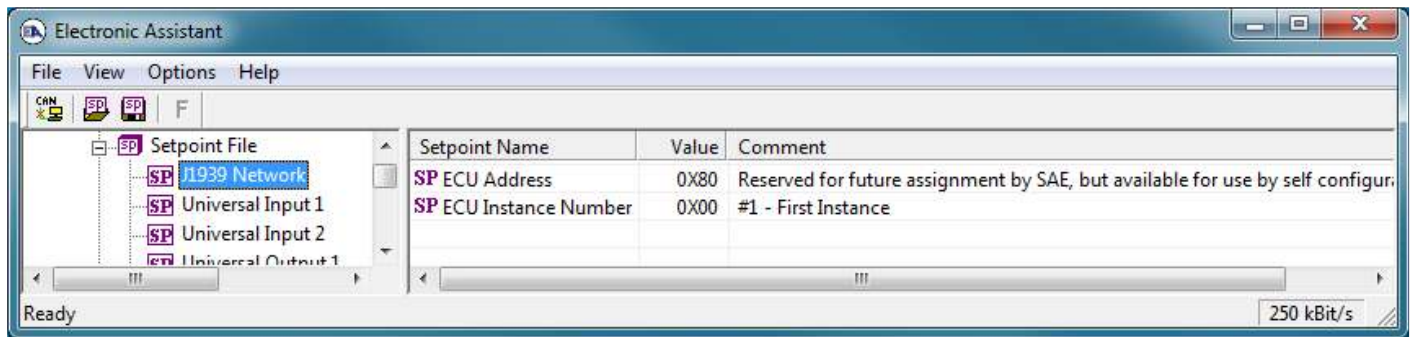

Figure 4 - Screen Capture of J1939 Setpoints

Name	Range	Default	Notes
ECU Address	0x80	0-253	Preferred address for a self-configurable ECU
ECU Instance	0-7	0x00	Per J1939-81

Table 12 – J1939 Network Setpoints

If non-default values for the “ECU Instance Number” or “ECU Address” are used, they will be mirrored during a setpoint file flashing, and will only take effect once the entire file has been downloaded to the unit. After the setpoint flashing is complete, the unit will claim the new address and/or re-claim the address with the new NAME. If these setpoints are changing, it is recommended to close and re-open the CAN connection on EA after the file is loaded so that only the new NAME and address are showing in the J1939 CAN Network ECU list.

### 3.3. PWM Output Setpoints

The PWM Output function Block is defined in Section 1.1. Please refer there for detailed information about how these setpoints are used.

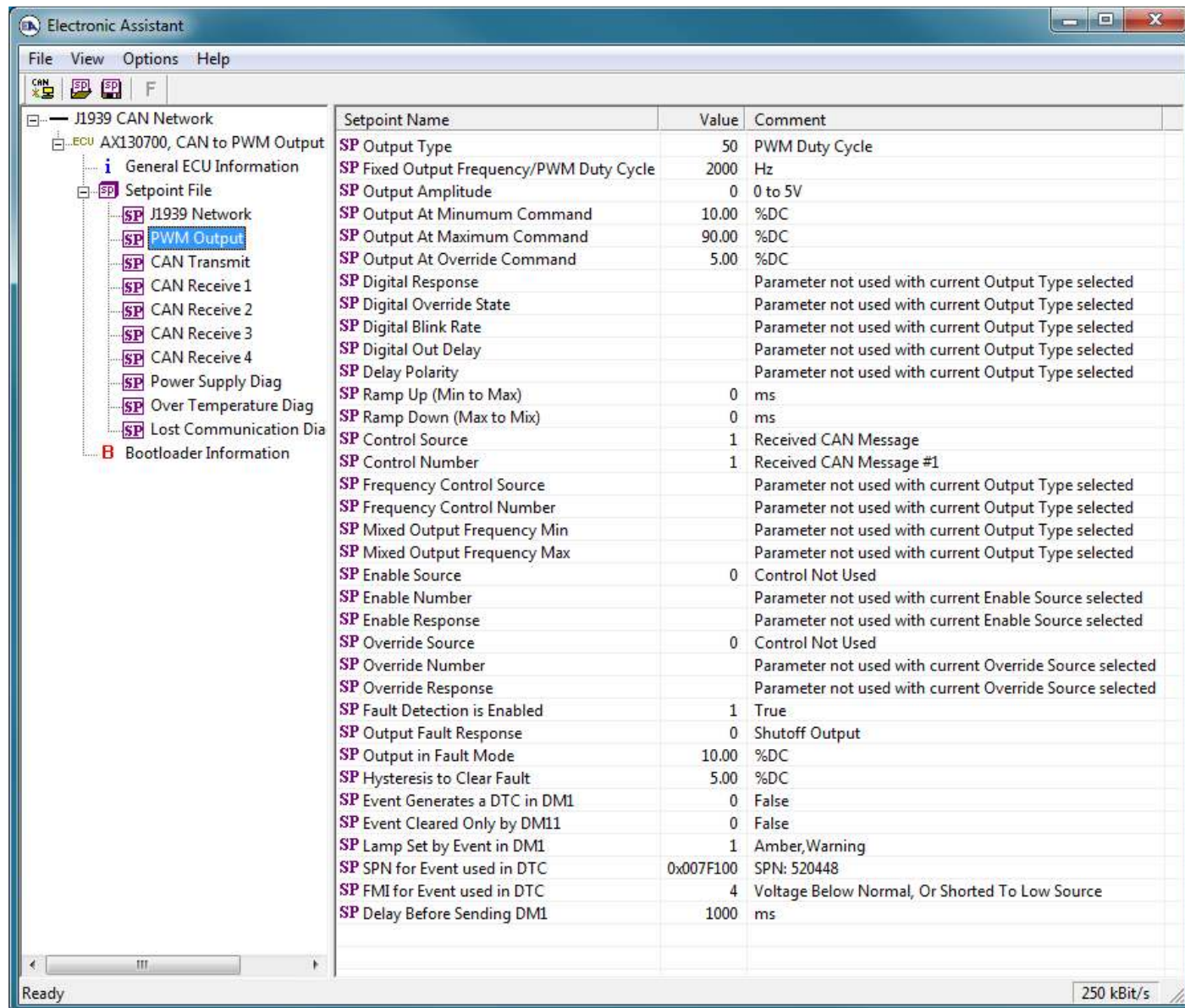

Figure 5 - Screen Capture of Universal Output Setpoints

Output type	Range Minimum	Range Maximum	Notes
Disabled	NA	NA	
Frequency 0Hz 20kHz	0.1Hz	20 000 Hz	
PWM Duty Cycle	0%	100%	
Mixed PWM and Frequency	0%	100%	

Table 13 – Output type ranges

Name	Range	Default	Notes
Output Type	Drop List	PWM Duty Cycle	See Table 1
Fixed Output Frequency/PWM Duty Cycle	0.1 to 100 % 0.1 Hz to 20 000 Hz	50 % 2000 Hz	
Frequency/PWM Amplitude	Drop List	0 to 5 V	
Output At Minimum Command	Depends on Output Type	Depends on Output Type	See Table 13
Output At Maximum Command	Depends on Output Type	Depends on Output Type	See Table 13
Output At Override Command	Depends on Output Type	Depends on Output Type	See Table 13
Ramp Up (Min to Max)	0 to 10 000ms	0ms	
Ramp Down (Max to Min)	0 to 10 000ms	0ms	
Digital Response	Drop List	Normal On/Off	See Table 2
Digital Override State	Drop List	ON	
Digital Blink Rate	100 to 5000 ms	1000ms	
Control Source	Drop List	Receive CAN Message	See Table 11
Control Number	Depends on control source	1	See Table 11
Frequency Control Source	Drop List	Receive CAN Message	See Table 11
Frequency Control Number	Depends on control source	2	See Table 11
Mixed Output Frequency Min	0.1 Hz to 20 000 Hz	50.0 Hz	
Mixed Output Frequency Max	0.1 Hz to 20 000 Hz	250.0 Hz	
Enable Source	Drop List	Control not used	See Table 11
Enable Number	Depends on enable source	1	See Table 11
Enable Response	Drop List	Enable When On, else Shutoff	See Table 4
Override Source	Drop List	Control not used	See Table 11
Override Number	Depends on override source	1	See Table 11
Override Response	Drop List	Override When On	See Table 5
Fault Detection is Enabled	Drop List	True	
Output Fault Response	Drop List	Shutoff Output	See Table 6
Output in Fault Mode	Limit to Limit	Depends on Output Type	See Table 13
Hysteresis to Clear Fault	Limit to Limit	Depends on Output Type	See Table 13
Event Generates a DTC by DM1	Drop List	True	
Event Cleared only by DM1	Drop List	False	
Lamp Set by Event in DM1	Drop List	Amber Warning	See Table 8
SPN for Event used in DTC	0..65535	520448	
FMI for Event used in DTC	Drop List	4	See Table 9
Delay Before Sending DM1	0..60000 ms	1000 ms	

**Table 14 –Output Setpoints**

### 3.4. CAN Transmit Setpoints

CAN Transmit Message Function Block is presented in Section 1.3. Please refer there for detailed information how these setpoints are used. **“Transmit Repetition Rate”** is 0ms by default, thus no message will be sent.

Setpoint Name	Value	Comment
SP Transmit PGN	0xFF00	Transmit PGN: 65280
SP Use 11bit ID	0	False
SP Transmit Repetition Rate	0	ms
SP Transmit Message Priority	6	
SP Destination Address (PDU1)	255	Destination ECU Address: 0xFF
SP Signal 1 Data Source	2	Output Target Value
SP Signal 1 Data Number	1	Output Target Value #1
SP Signal 1 Transmit Data Size	5	Continuous 2-Bytes
SP Signal 1 Transmit Data Index in Array (LSB)	0	1st Byte Position
SP Signal 1 Transmit Bit Index in Byte (LSB)		Parameter not used with current Data Size selected
SP Signal 1 Transmit Data Resolution	0.0010000	
SP Signal 1 Transmit Data Offset	0.0000000	
SP Signal 2 Data Source	0	Control Not Used
SP Signal 2 Data Number		Parameter not used with current Data Source
SP Signal 2 Transmit Data Size		Parameter not used with current Data Source
SP Signal 2 Transmit Data Index in Array (LSB)		Parameter not used with current Data Source
SP Signal 2 Transmit Bit Index in Byte (LSB)		Parameter not used with current Data Source
SP Signal 2 Transmit Data Resolution		Parameter not used with current Data Source
SP Signal 2 Transmit Data Offset		Parameter not used with current Data Source
SP Signal 3 Data Source	0	Control Not Used
SP Signal 3 Data Number		Parameter not used with current Data Source
SP Signal 3 Transmit Data Size		Parameter not used with current Data Source
SP Signal 3 Transmit Data Index in Array (LSB)		Parameter not used with current Data Source
SP Signal 3 Transmit Bit Index in Byte (LSB)		Parameter not used with current Data Source
SP Signal 3 Transmit Data Resolution		Parameter not used with current Data Source
SP Signal 3 Transmit Data Offset		Parameter not used with current Data Source
SP Signal 4 Data Source	0	Control Not Used
SP Signal 4 Data Number		Parameter not used with current Data Source
SP Signal 4 Transmit Data Size		Parameter not used with current Data Source
SP Signal 4 Transmit Data Index in Array (LSB)		Parameter not used with current Data Source
SP Signal 4 Transmit Bit Index in Byte (LSB)		Parameter not used with current Data Source
SP Signal 4 Transmit Data Resolution		Parameter not used with current Data Source
SP Signal 4 Transmit Data Offset		Parameter not used with current Data Source

Figure 6 - Screen Capture of CAN Transmit Message Setpoints

Name	Range	Default	Notes
Transmit PGN	0x0000 ... 0xffff	Different for each	See Section 1.3.1
Use 11bit ID	Drop List	False	11bit/29bit frame ID in use
Transmit Repetition Rate	0 ... 65000 ms	0ms	0ms disables transmit
Transmit Message Priority	0...7	6	Proprietary B Priority
Destination Address	0...255	255	Not used by default
Signal 1 Control Source	Drop List	Signal undefined	See Table 11
Signal 1 Control Number	Drop List	Signal undefined	See 1.3.2
Signal 1 Transmit Data Size	Drop List	2 bytes	
Signal 1 Transmit Data Index in Array	0-7	0	
Signal 1 Transmit Bit Index In Byte	0-7	0	
Signal 1 Transmit Data Resolution	-100000.0 to 100000	0.001	
Signal 1 Transmit Data Offset	-10000 to 10000	0.0	
Signal 2 Control Source	Drop List	Signal undefined	See Table 11
Signal 2 Control Number	Drop List	Signal undefined	See 1.3.2
Signal 2 Transmit Data Size	Drop List	2 bytes	
Signal 2 Transmit Data Index in Array	0-7	2	
Signal 2 Transmit Bit Index In Byte	0-7	0	
Signal 2 Transmit Data Resolution	-100000.0 to 100000	0.001	
Signal 2 Transmit Data Offset	-10000 to 10000	0.0	
Signal 3 Control Source	Drop List	Signal undefined	See Table 11
Signal 3 Control Number	Drop List	Signal undefined	See 1.3.2
Signal 3 Transmit Data Size	Drop List	2 bytes	
Signal 3 Transmit Data Index in Array	0-7	4	
Signal 3 Transmit Bit Index In Byte	0-7	0	
Signal 3 Transmit Data Resolution	-100000.0 to 100000	0.001	
Signal 3 Transmit Data Offset	-10000 to 10000	0.0	
Signal 4 Control Source	Drop List	Signal undefined	See Table 11
Signal 4 Control Number	Drop List	Signal undefined	See 1.3.2
Signal 4 Transmit Data Size	Drop List	2 bytes	
Signal 4 Transmit Data Index in Array	0-7	6	
Signal 4 Transmit Bit Index In Byte	0-7	0	
Signal 4 Transmit Data Resolution	-100000.0 to 100000	0.001	
Signal 4 Transmit Data Offset	-10000 to 10000	0.0	

**Table 15 – CAN Transmit Message Setpoints**

### 3.5. CAN Receive Setpoints

The Math Function Block is defined in Section 1.4. Please refer there for detailed information about how these setpoints are used. **“Receive Message Timeout”** is set to 0ms by default. To enable Receive message set **“Receive Message Timeout”** that differs from zero.

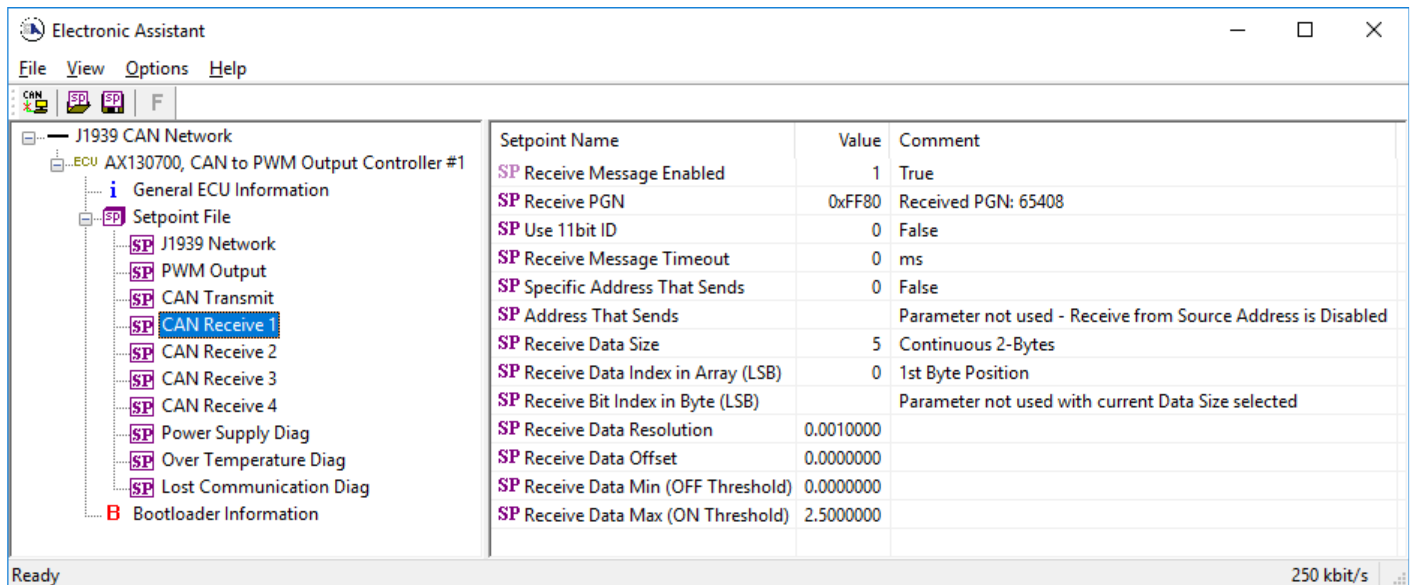

**Figure 7 - Screen Capture of CAN Receive Message Setpoints**

Name	Range	Default	Notes
Received Message Enabled	Drop List	False	
Received PGN	0 to 65536	Different for each	
Use 11bit ID	Drop List	False	
Received Message Timeout	0 to 60 000 ms	0ms	
Specific Address that sends PGN	Drop List	False	
Address That Sends	0 to 255	254 (0xFE, Null Addr)	
Receive Transmit Data Size	Drop List	2 bytes	
Receive Transmit Data Index in Array	0-7	0	
Receive Transmit Bit Index In Byte	0-7	0	
Receive Transmit Data Resolution	-100000.0 to 100000	0.001	
Receive Transmit Data Offset	-10000 to 10000	0.0	
Receive Data Min (Off Threshold)	-1000000 to Max	0.0	
Receive Data Max (On Threshold)	-100000 to 100000	2.5	

**Table 16 – CAN Receive Setpoints**

### 3.6. Diagnostic Setpoints

There are three fault diagnostic setpoint groups namely Power Supply Diagnostic, Over Temperature Diagnostic and Lost Communication Diagnostic. Setpoints of these groups are presented in tables below. The Diagnostic Function Block is defined in 1.1. Please refer there for detailed information how these setpoints are used.

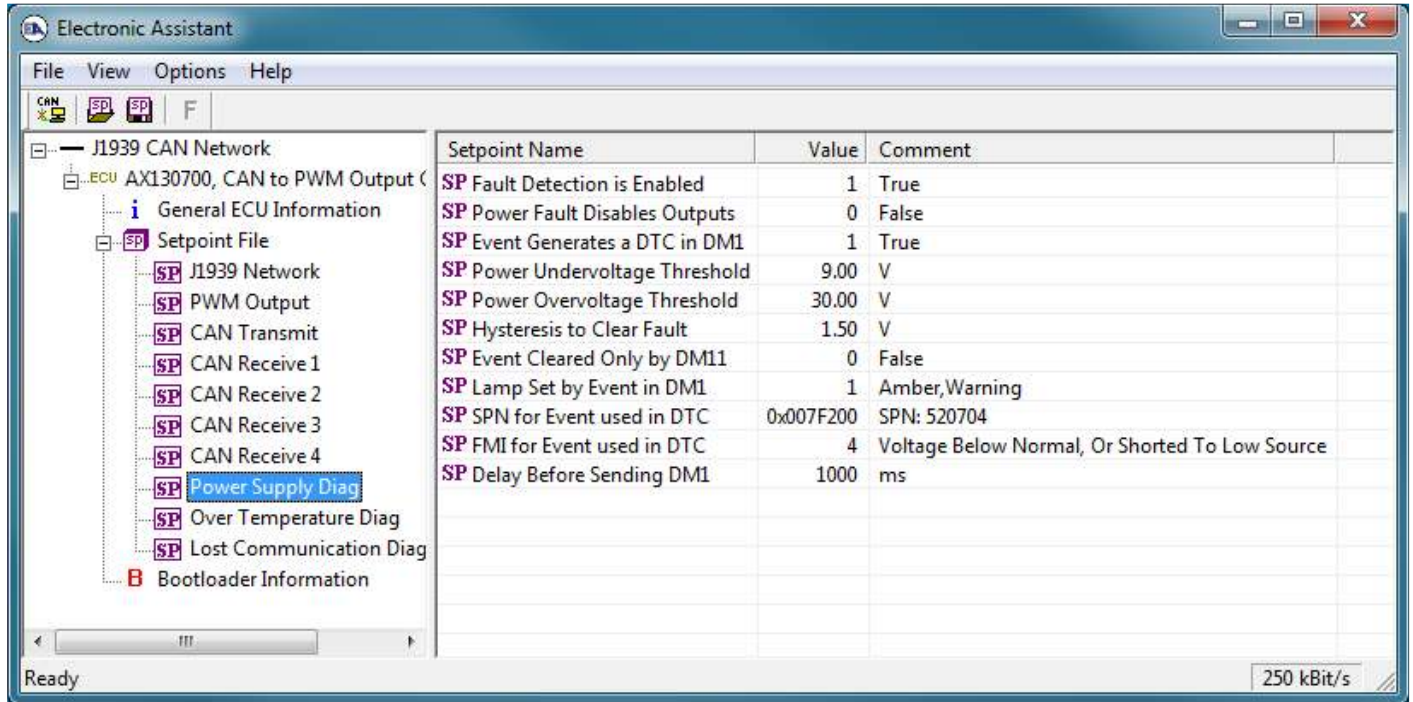

The screenshot shows the 'Electronic Assistant' window with a tree view on the left and a table of setpoints on the right. The tree view is expanded to 'Power Supply Diag'. The table lists the following setpoints:

Setpoint Name	Value	Comment
SP Fault Detection is Enabled	1	True
SP Power Fault Disables Outputs	0	False
SP Event Generates a DTC in DM1	1	True
SP Power Undervoltage Threshold	9.00	V
SP Power Overvoltage Threshold	30.00	V
SP Hysteresis to Clear Fault	1.50	V
SP Event Cleared Only by DM11	0	False
SP Lamp Set by Event in DM1	1	Amber,Warning
SP SPN for Event used in DTC	0x007F200	SPN: 520704
SP FMI for Event used in DTC	4	Voltage Below Normal, Or Shorted To Low Source
SP Delay Before Sending DM1	1000	ms

Figure 8 - Screen Capture of Power Supply Diagnostic Setpoints

Name	Range	Default	Notes
Fault Detection is Enabled	Drop List	True	
Power Fault Disables Outputs	Drop List	False	
Event Generates a DTC by DM1	Drop List	False	
Power Undervoltage Threshold	From 5V to overvoltage threshold	9V	
Power Overvoltage Threshold	From undervoltage threshold to 100V	30V	
Hysteresis to Clear Fault	From range min to range max/2	1.5V	
Event Cleared only by DM11	Drop List	False	
Lamp Set by Event in DM1	Drop List	Amber Warning	See Table 8
SPN for Event used in DTC	0...65535	520704 (\$7F200)	It is the user's responsibility to select an SPN that will not violate the J1939 standard.
FMI for Event used in DTC	Drop List	4, Voltage Below Normal	See Table 9
Delay Before Sending DM1	0...60000 ms	1000	

**Table 17 – Power Supply Diagnostic Setpoints**

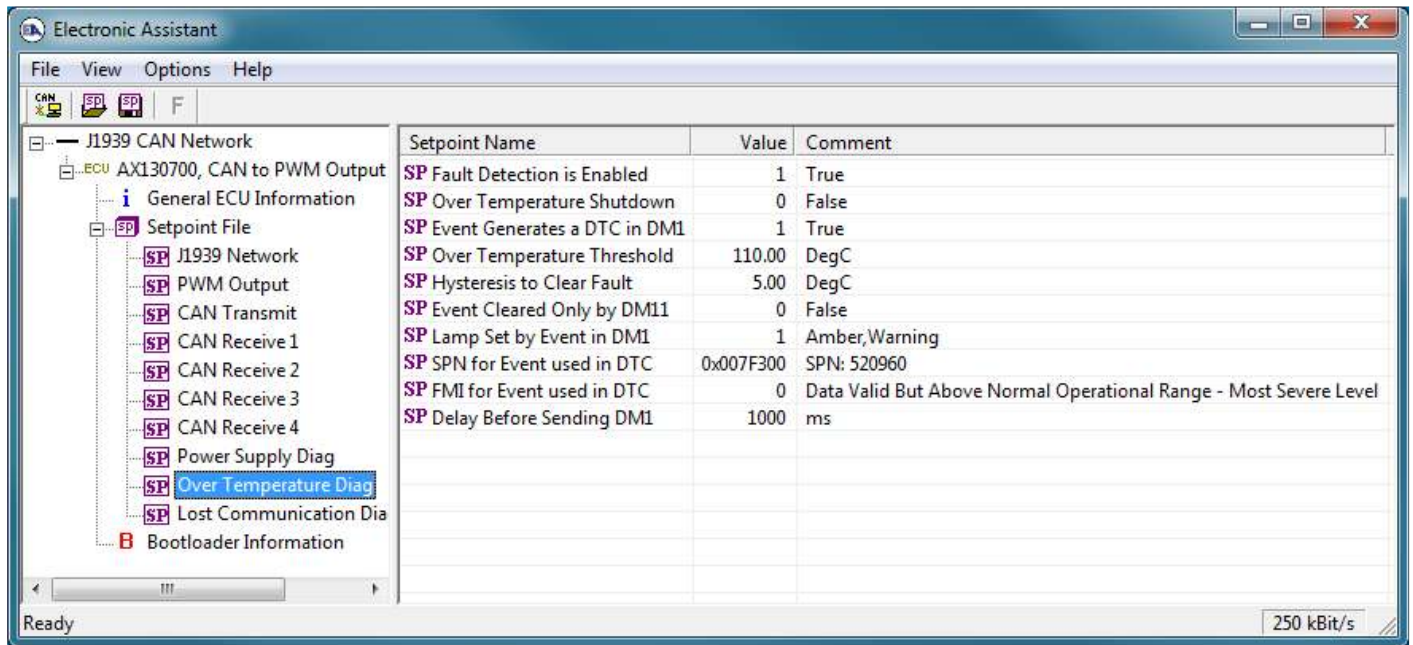
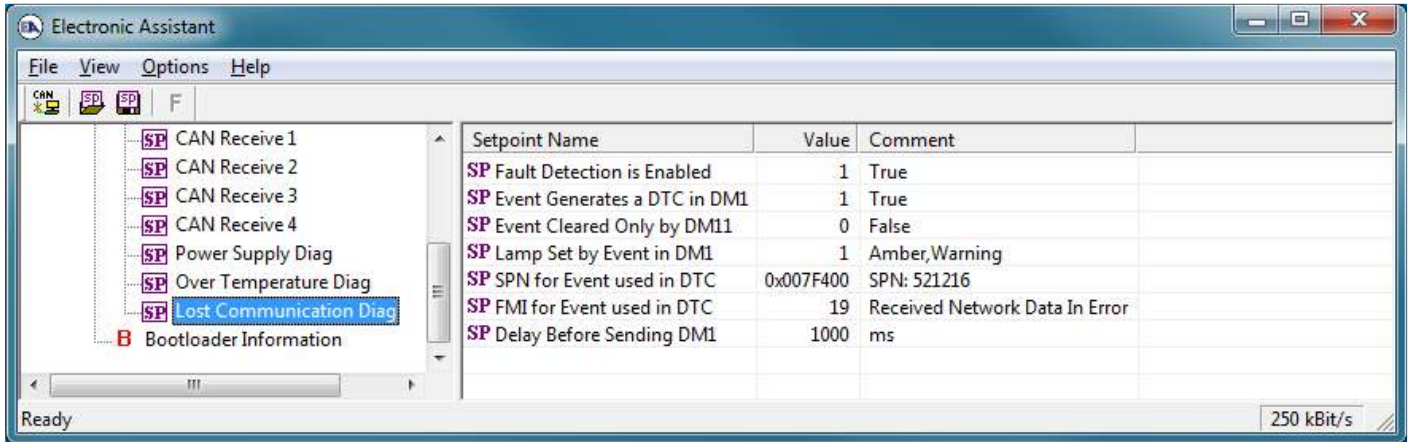

**Figure 9 - Screen Capture of Over Temperature Diagnostic Setpoints**

Name	Range	Default	Notes
Fault Detection is Enabled	Drop List	True	
Over Temperature Shutdown	Drop List	False	
Event Generates a DTC by DM1	Drop List	False	
Power Over Temperature Threshold	From 50°C to 150°C	110°C	
Hysteresis to Clear Fault	From 0°C to 50°C	5°C	

Event Cleared only by DM11	Drop List	False	
Lamp Set by Event in DM1	Drop List	Amber Warning	See Table 8
SPN for Event used in DTC	0...65535	520960 (\$7F300)	It is the user's responsibility to select an SPN that will not violate the J1939 standard.
FMI for Event used in DTC	Drop List	0, Data Above Normal – Most Sever	See Table 9
Delay Before Sending DM1	0...60000 ms	1000	

**Table 18 – Over Temperature Diagnostic Setpoints**



**Figure 10 - Screen Capture of Lost Communication Diagnostic Setpoints**

Name	Range	Default	Notes
Fault Detection is Enabled	Drop List	True	
Event Generates a DTC by DM1	Drop List	False	
Event Cleared only by DM11	Drop List	False	
Lamp Set by Event in DM1	Drop List	Amber Warning	See Table 8
SPN for Event used in DTC	0...65535	521216 (\$7F400)	It is the user's responsibility to select an SPN that will not violate the J1939 standard.
FMI for Event used in DTC	Drop List	19, Received Data Error	See Table 9
Delay Before Sending DM1	0...60000 ms	1000	

**Table 19 – Lost Communication Diagnostic Setpoints**

## 4. REFLASHING OVER CAN WITH EA BOOTLOADER

The AX130700 can be upgraded with new application firmware using the **Bootloader Information** section. This section details the simple step-by-step instructions to upload new firmware provided by Axiomatic onto the unit via CAN, without requiring it to be disconnected from the J1939 network.

*Note: To upgrade the firmware use Electronic Assistant ® V4.10.77.0 or higher.*

1. When EA first connects to the ECU, the **Bootloader Information** section will display the following information.

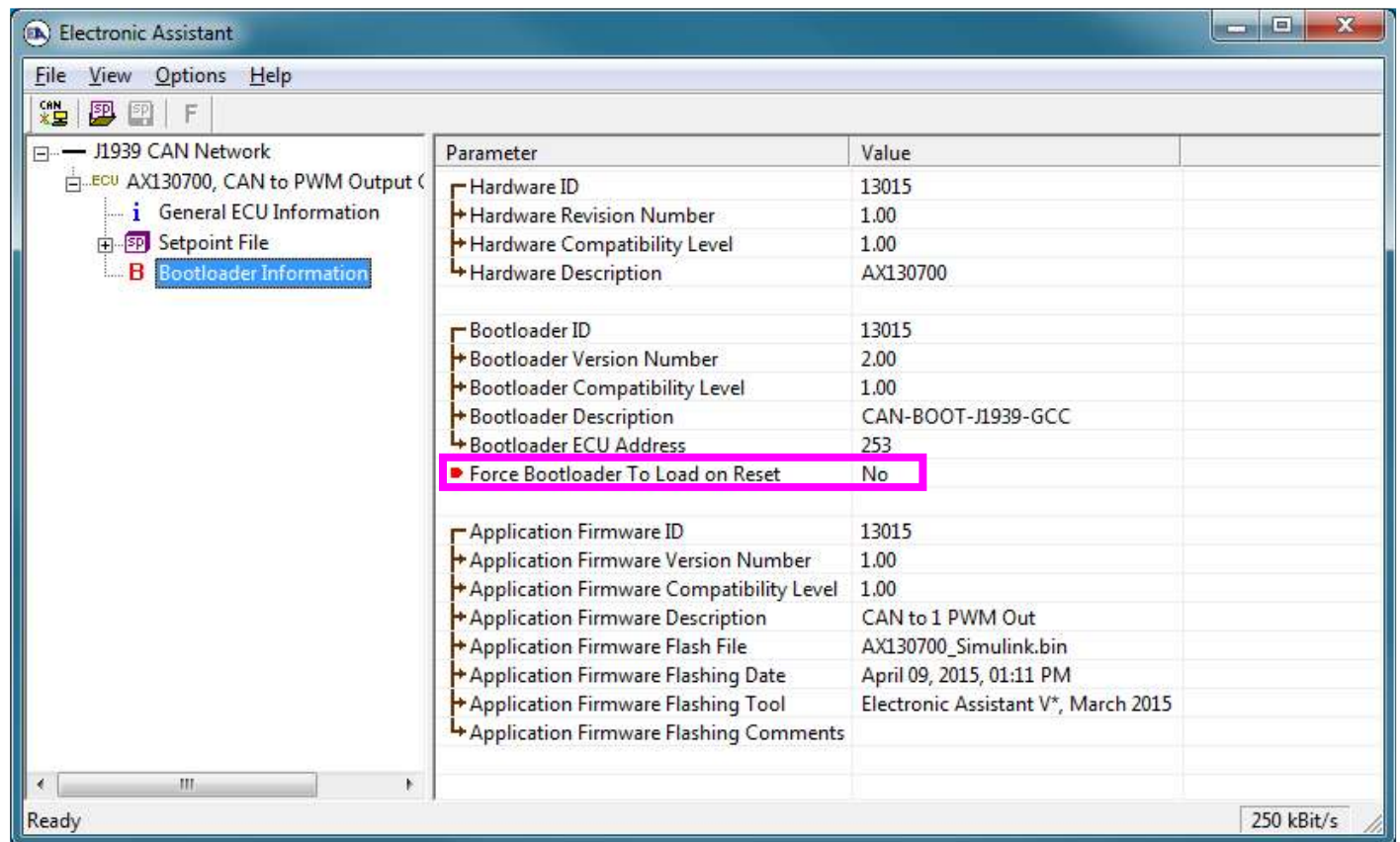

2. To use the bootloader to upgrade the firmware running on the ECU, change the variable **“Force Bootloader To Load on Reset”** to Yes.

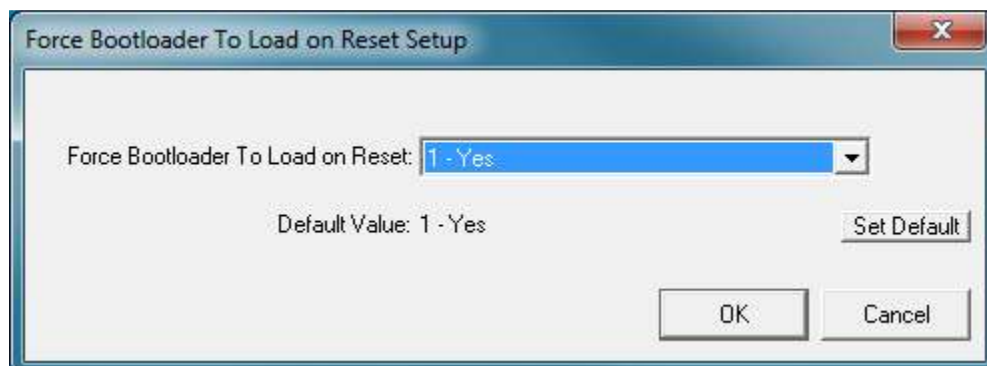

3. When the prompt box asks if you want to reset the ECU, select Yes.

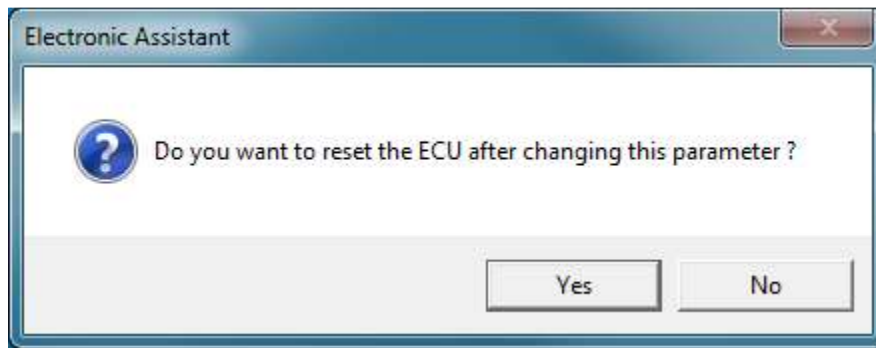

4. Upon reset, the ECU will no longer show up on the J1939 network as an AX130700 but rather as **J1939 Bootloader #1**.

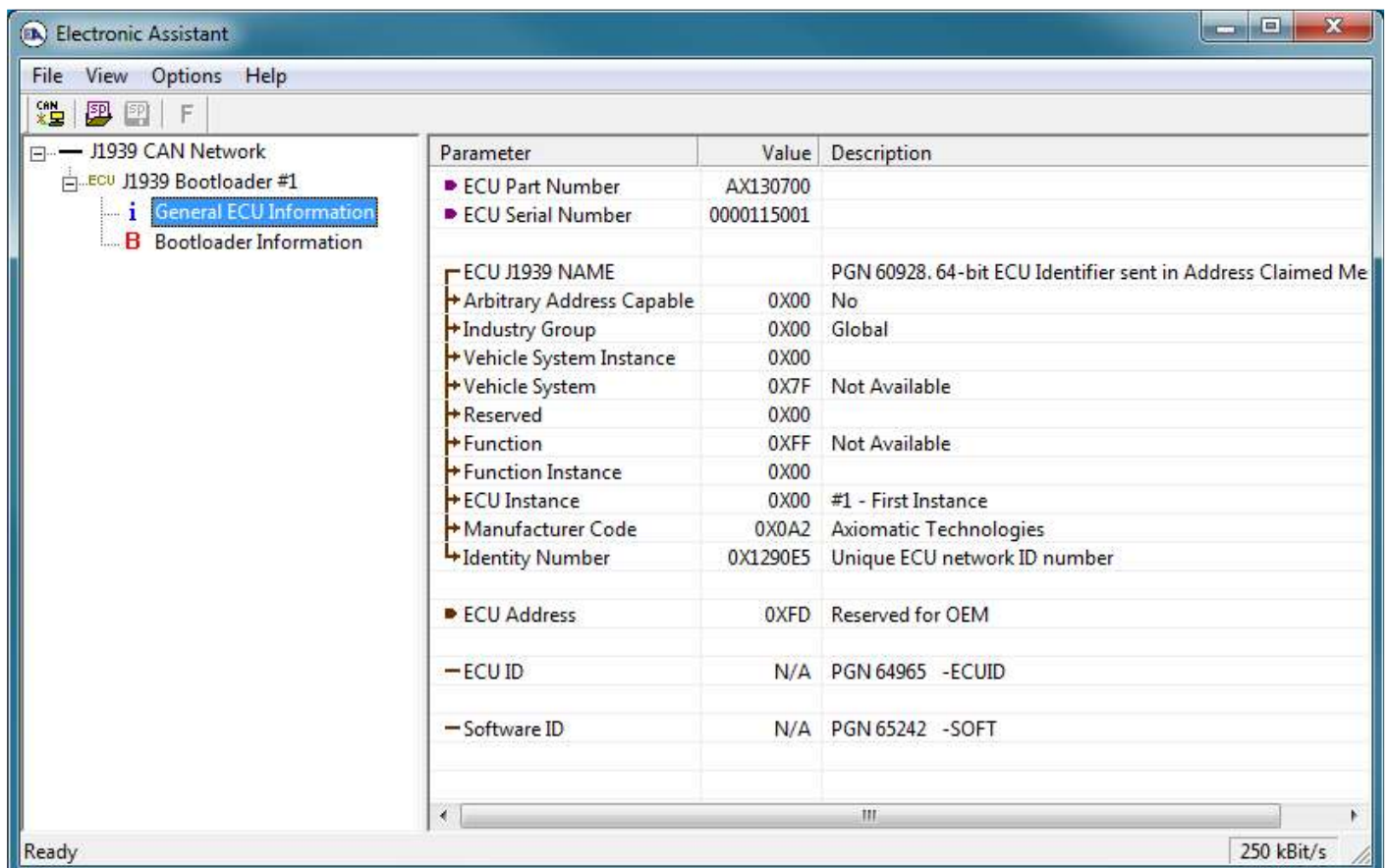
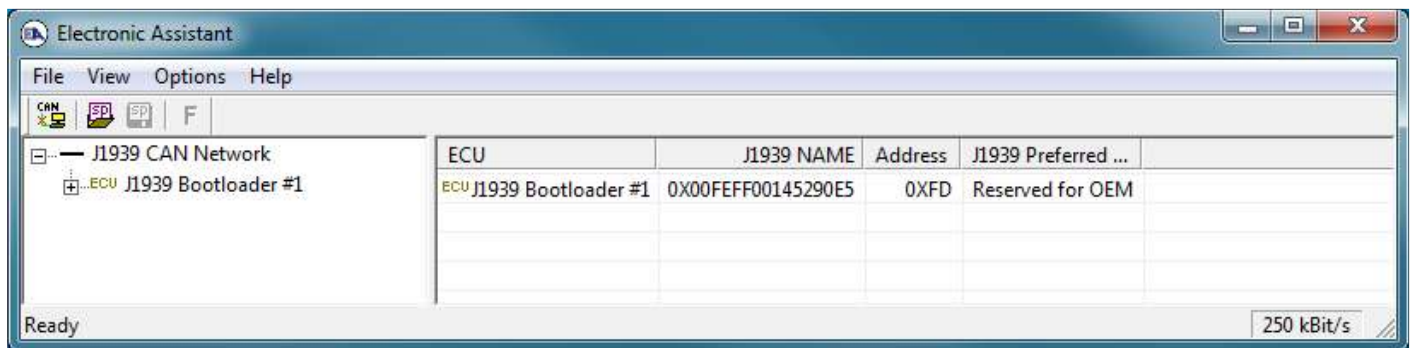

Note that the bootloader is NOT Arbitrary Address Capable. This means that if you want to have multiple bootloaders running simultaneously (not recommended) you would have to manually change the address for each one before activating the next, or there will be address conflicts. And only one ECU would show up as the bootloader. Once the 'active' bootloader returns to regular functionality, the other ECU(s) would have to be power cycled to re-activate the bootloader feature.

- When the **Bootloader Information** section is selected, the same information is shown as when it was running the AX130700 firmware, but in this case the **Flashing** feature has been enabled.

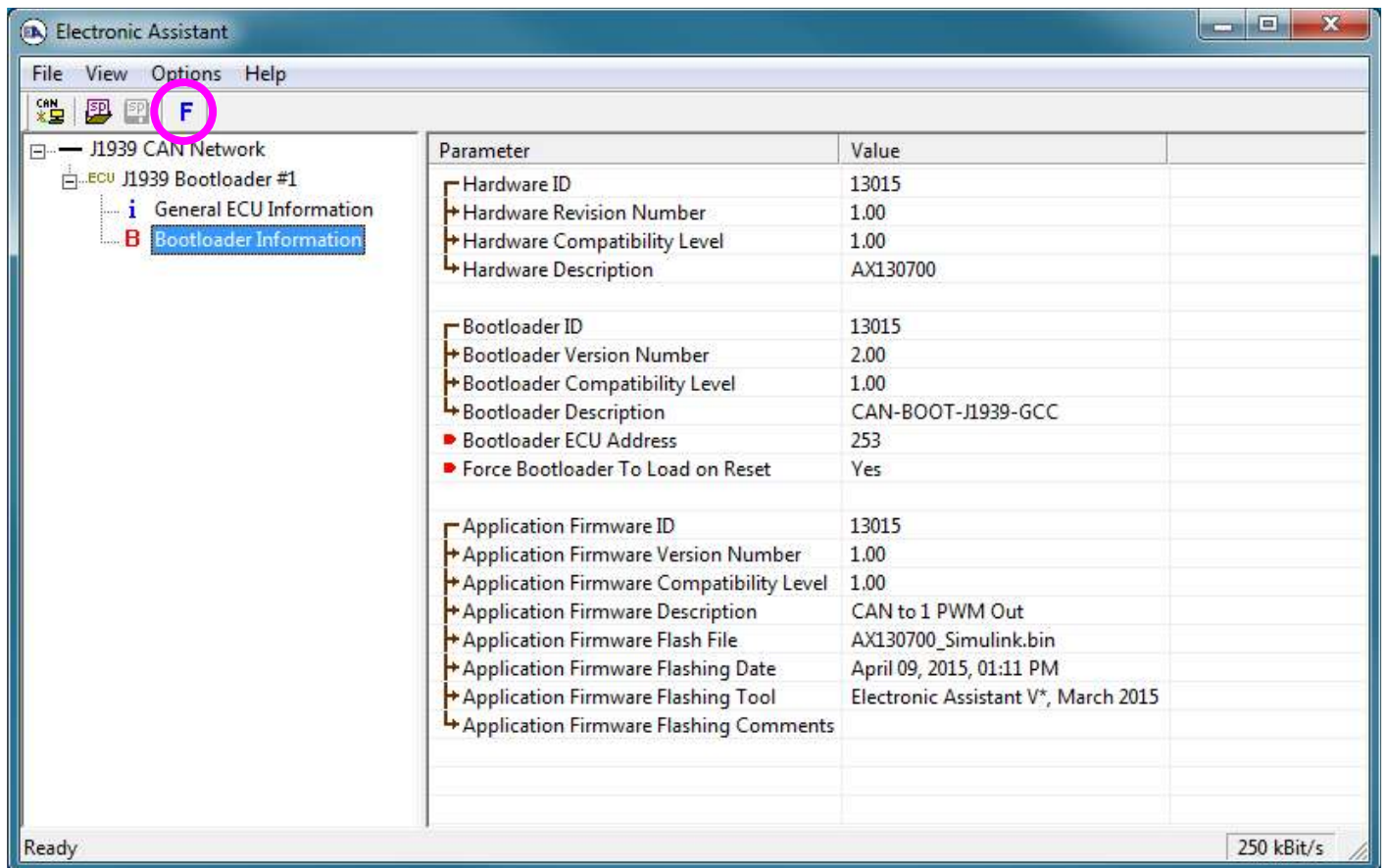

- Select the **Flashing** button and navigate to where you had saved the **AX130700\_Simulink.bin** file sent from Axiomatic. (Note: only binary (.bin) files can be flashed using the EA tool.)
- Once the Flash Application Firmware window opens, you can enter comments such as "Firmware upgraded by [Name]" if you so desire. This is not required, and you can leave the field blank if you do not want to use it.

Note: You do not have to date/time-stamp the file, as this is done automatically by the EA tool when you upload the new firmware.

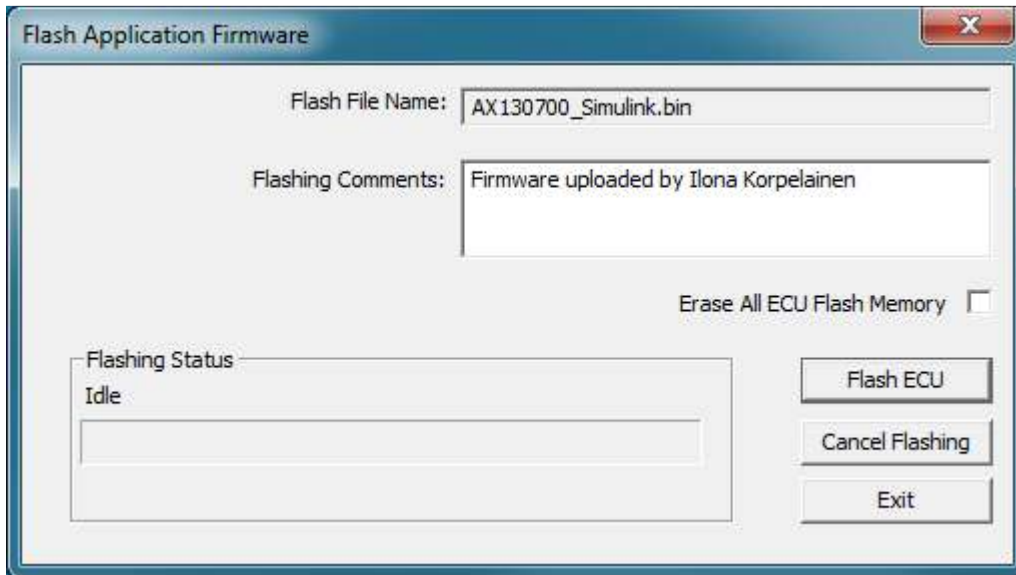

**WARNING:** Do not check the “Erase All ECU Flash Memory” box unless instructed to do so by your Axiomatic contact. Selecting this will erase ALL data stored in non-volatile flash including the calibration from Axiomatic factory testing. It will also erase any configuration of the setpoints that might have been done to the ECU and reset all setpoints to their factory defaults. By leaving this box unchecked, none of the setpoints will be changed when the new firmware is uploaded.

A progress bar will show how much of the firmware has been sent as the upload progresses. The more traffic there is on the J1939 network, the longer the upload process will take.

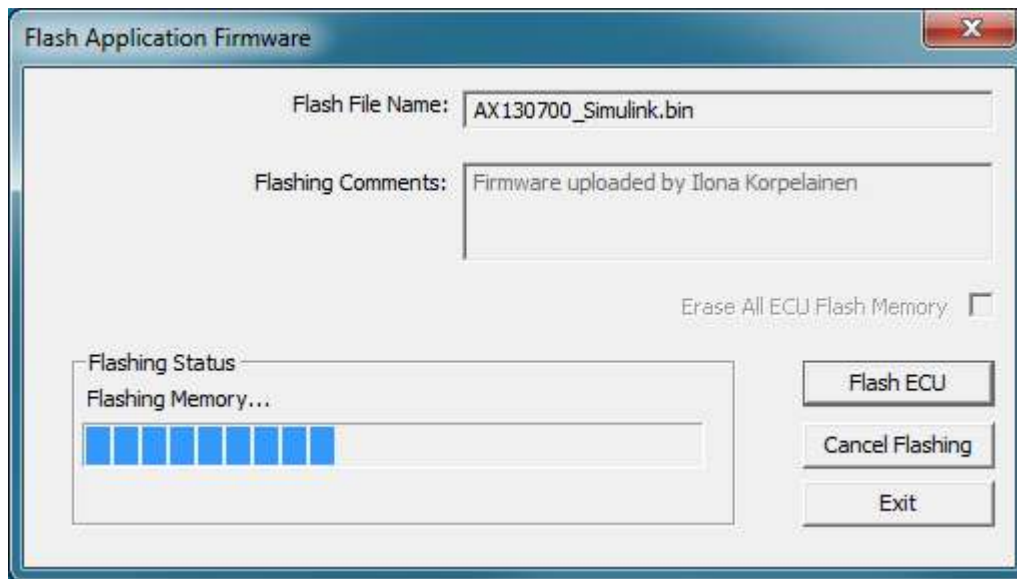

Once the firmware has finished uploading, a message will pop up indicating the successful operation. If you select to reset the ECU, the new version of the AX130700 application will start

running, and the ECU will be identified as such by EA. Otherwise, the next time the ECU is power-cycled, the AX130700 application will run rather than the bootloader function.



Note: If at any time during the upload the process is interrupted, the data is corrupted (bad checksum) or for any other reason the new firmware is not correct, i.e. bootloader detects that the file loaded was not designed to run on the hardware platform, the bad or corrupted application will not run. Rather, when the ECU is reset or power-cycled the **J1939 Bootloader** will continue to be the default application until valid firmware has been successfully uploaded into the unit.

## APPENDIX A - TECHNICAL SPECIFICATION

---

### Technical Specifications:

Specs are typical at nominal input voltage and 25 degrees C unless otherwise specified.

#### Power Supply

Power Supply Input - Nominal	12 V or 24 Vdc nominal; 9...36 Vdc The minimum allowable supply voltage for the power pin is 7 Vdc.
Surge Protection	Meets the surge requirements of SAE J1445
Reverse Polarity Protection	Provided

#### Outputs

Signal Output	1 Output configurable as PWM/Frequency or Digital  PWM Signal, Frequency Signal or Mixed Output <ul style="list-style-type: none"><li>• 1 Hz to 20 kHz</li><li>• 0-100% D.C. (User configurable)</li><li>• 5V or 12V amplitude</li><li>• Push pull output</li><li>• Maximum load is 50 mA.</li><li>• Over-current protection (50 mA)</li></ul> Digital Level <ul style="list-style-type: none"><li>• Digital On/Off</li><li>• 5V or 12V Amplitude</li><li>• Maximum load is 50 mA.</li></ul>
---------------	---

#### Control Software

Software Platform	The CAN-PWM Signal Converter comes pre-programmed with standard logic. Convert CAN messages to PWM signals for communicating with legacy Engine Control Modules.
-------------------	--

#### General Specifications

Memory	STM32F103CBT7 32-bit, 128 Kbytes Flash Program Memory
CAN Port	1 CAN (SAE J1939, autobaud rate support, default 250 kBit/s)
Isolation	300 Vrms isolation for CAN port
Quiescent Current Draw	16 mA @ 24Vdc typical
Response Time	33 mSec. typical
Operating Conditions	-40 to 85°C (-40 to 185°F)
Weight	0.15 lbs. (0.068 kg)
Protection Rating	IP67
Vibration	MIL-STD-202G, Test 204D and 214A (Sine and Random) 10 g peak (Sine) 7.86 Grms peak (Random)
Shock	MIL-STD-202G, Test 213B 50 g

Enclosure and Dimensions	Plastic Enclosure, Nylon 6-6 with 30% glass fill Integral Deutsch IPD connector Refer to the dimensional drawing.																
Electrical Connections	6 pin Deutsch IPD connector P/N: DT04-6P A mating plug kit is available as Axiomatic P/N: <b>AX070119</b> .  <table border="1"> <thead> <tr> <th colspan="2">CAN and I/O Connector</th> </tr> <tr> <th>Pin #</th> <th>Description</th> </tr> </thead> <tbody> <tr> <td>1</td> <td>BATT+</td> </tr> <tr> <td>2</td> <td>OUT+</td> </tr> <tr> <td>3</td> <td>CAN_H</td> </tr> <tr> <td>4</td> <td>CAN_L</td> </tr> <tr> <td>5</td> <td>OUT-</td> </tr> <tr> <td>6</td> <td>BATT-</td> </tr> </tbody> </table>	CAN and I/O Connector		Pin #	Description	1	BATT+	2	OUT+	3	CAN_H	4	CAN_L	5	OUT-	6	BATT-
CAN and I/O Connector																	
Pin #	Description																
1	BATT+																
2	OUT+																
3	CAN_H																
4	CAN_L																
5	OUT-																
6	BATT-																
Software Reflashing	Electronic Assistant® <b>AX070502</b>																
User Interface	For SAE J1939 models, parameters are configurable using the Electronic Assistant®, P/N: AX070502. It requires an Axiomatic USB-CAN converter to link the device's CAN port to a <i>Windows</i> -based PC.																

### Dimensional Drawing

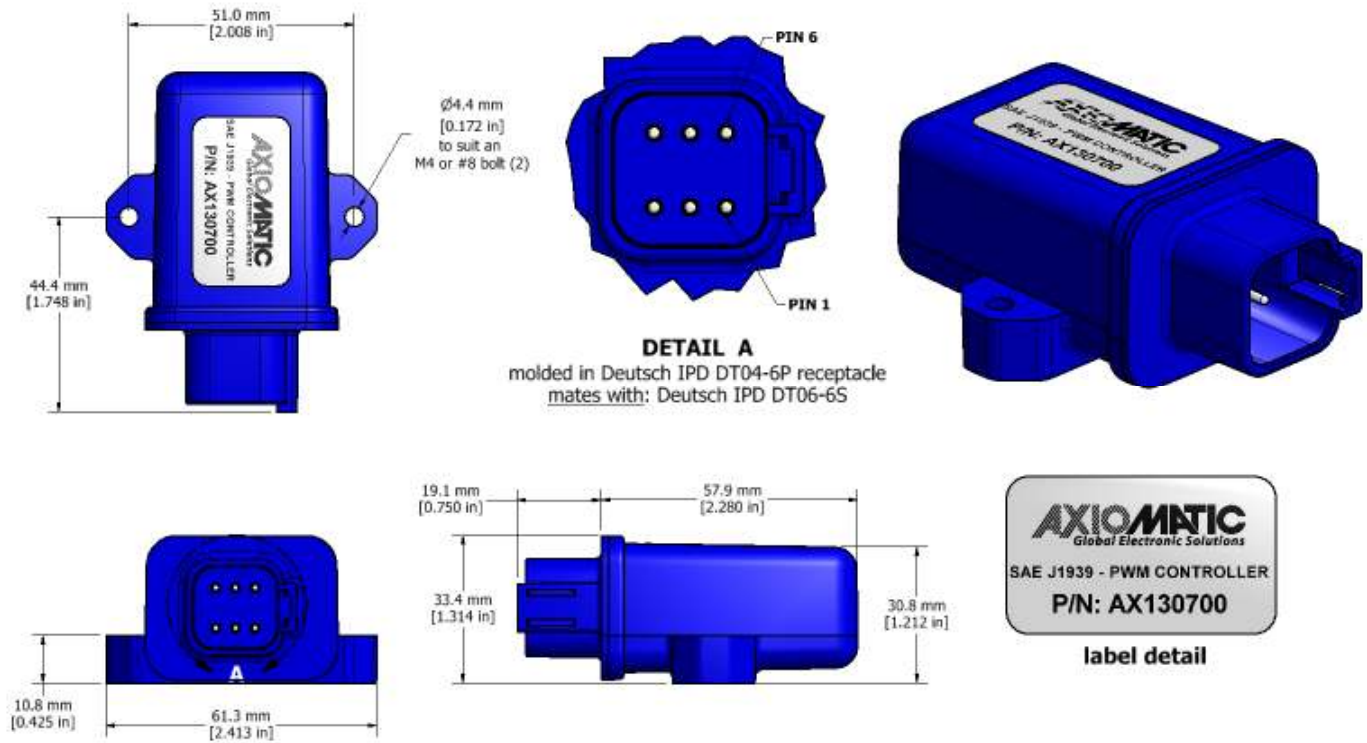

## OUR PRODUCTS

AC/DC Power Supplies  
Actuator Controls/Interfaces  
Automotive Ethernet Converters  
Battery Chargers  
CAN Controls, Routers, Repeaters  
CAN/WiFi, CAN/Bluetooth, Routers  
Current/Voltage Converters  
DC/DC Power Converters  
Engine Temperature Scanners  
Ethernet/CAN Converters,  
Gateways, Switches  
Fan Drive Controllers  
Gateways, CAN/Modbus Protocols  
Gyroscope Inclinometers  
Hydraulic Valve Controllers  
Inclinometers, Triaxial  
I/O Controls  
LVDT Signal Converters  
Machine Controls  
Modbus Controls  
Motor Controls  
Power Supplies, DC/DC, AC/DC  
PWM Signal Converters/Isolators  
Resolver Signal Conditioners  
Service Tools  
Signal Conditioners, Converters  
Strain Gauge CAN Controls  
Surge Suppressors

## OUR COMPANY

Axiomatic provides electronic machine control components to the off-highway, commercial vehicle, electric vehicle, power generator set, material handling, renewable energy and industrial OEM markets. ***We innovate with engineered and off-the-shelf machine controls that add value for our customers.***

## QUALITY DESIGN AND MANUFACTURING

We have an ISO9001:2015 registered design/manufacturing facility in Canada.

## WARRANTY, APPLICATION APPROVALS/LIMITATIONS

Axiomatic Technologies Corporation reserves the right to make corrections, modifications, enhancements, improvements, and other changes to its products and services at any time and to discontinue any product or service without notice. Customers should obtain the latest relevant information before placing orders and should verify that such information is current and complete. Users should satisfy themselves that the product is suitable for use in the intended application. All our products carry a limited warranty against defects in material and workmanship. Please refer to our Warranty, Application Approvals/Limitations and Return Materials Process at <https://www.axiomatic.com/service/>.

## COMPLIANCE

Product compliance details can be found in the product literature and/or on [axiomatic.com](http://axiomatic.com). Any inquiries should be sent to [sales@axiomatic.com](mailto:sales@axiomatic.com).

## SAFE USE

All products should be serviced by Axiomatic. Do not open the product and perform the service yourself.



This product can expose you to chemicals which are known in the State of California, USA to cause cancer and reproductive harm. For more information go to [www.P65Warnings.ca.gov](http://www.P65Warnings.ca.gov).

## SERVICE

All products to be returned to Axiomatic require a Return Materials Authorization Number (RMA#) from [sales@axiomatic.com](mailto:sales@axiomatic.com). Please provide the following information when requesting an RMA number:

- Serial number, part number
- Runtime hours, description of problem
- Wiring set up diagram, application and other comments as needed

## DISPOSAL

Axiomatic products are electronic waste. Please follow your local environmental waste and recycling laws, regulations and policies for safe disposal or recycling of electronic waste.

## CONTACTS

**Axiomatic Technologies Corporation**  
5915 Wallace Street  
Mississauga, ON  
CANADA L4Z 1Z8  
TEL: +1 905 602 9270  
FAX: +1 905 602 9279  
[www.axiomatic.com](http://www.axiomatic.com)  
[sales@axiomatic.com](mailto:sales@axiomatic.com)

**Axiomatic Technologies Oy**  
Höytämöntie 6  
33880 Lempäälä  
FINLAND  
TEL: +358 103 375 750  
FAX: +358 3 3595 660  
[www.axiomatic.com](http://www.axiomatic.com)  
[salesfinland@axiomatic.com](mailto:salesfinland@axiomatic.com)