

LIN – CANopen® Protocol Converter

P/N: AX140603

In Europe:
Axiomatic Technologies Oy
Höytämöntie 6
33880 LEMPÄÄLÄ - Finland
Tel. +358 103 375 750
Fax. +358 3 3595 660
www.axiomatic.fi

In North America:
Axiomatic Technologies Corporation
5915 Wallace Street
Mississauga, ON Canada L4Z 1Z8
Tel. 1 905 602 9270
Fax. 1 905 602 9279
www.axiomatic.com

VERSION HISTORY

Version	Date	Author	Modification
1.0.0.	August 6, 2019	Erik Sasse	Initial Draft
	August 6, 2019	Amanda Wilkins	Marketing Review
1.1	October 15, 2019	Erik Sasse	Added comment on changing LIN Baud Rate

ACRONYMS

CAN	Controller Area Network
DM	Diagnostic message. Defined in J1939/73 standard
EA	Electronic Assistant. PC application software from Axiomatic, primarily designed to view and program Axiomatic control configuration parameters (setpoints) through CAN bus using J1939 Memory Access Protocol
ECU	Electronic control unit
EMI	Electromagnetic Interference
LIN	Local Interconnect Network. Automotive network maintained by the LIN Consortium
LSB	Less Significant Byte
PC	Personal Computer
PGN	Parameter Group Number. Defined in J1939/73 standard
P/N	Part Number
RS-232	PC serial port interface
CANopen	CAN-based higher level protocol designed and supported by CAN in Automation (CiA)
USB	Universal Serial Bus
UTP	Un-shielded twisted pair
BCD	Binary Code Decimal

Contents

1	INTRODUCTION.....	1
2	CONVERTER DESCRIPTION.....	2
2.1	Hardware Block Diagram	2
2.2	LIN Interface.....	2
3	CONVERTER LOGICAL STRUCTURE	4
3.1	Function Block Signals.....	5
3.1.1	Undefined Signal.....	5
3.1.2	Discrete Signal	5
3.1.3	Continuous Signal	5
3.1.4	Signal Type Conversion.....	6
3.2	LIN Interface.....	6
3.2.1	LIN Common	6
3.2.2	LIN Signal	7
3.2.3	LIN Slave Response	9
3.2.4	LIN Unconditional Frame.....	10
3.2.5	LIN Event Triggered Frame	11
3.2.6	LIN Sporadic Frame.....	12
3.2.7	Main Schedule Table	13
3.2.8	Collision Schedule Table.....	14
3.3	Binary Functions.....	15
3.4	Global Parameters	18
3.5	CAN Interface.....	18
3.5.1	CANopen Network.....	18
3.5.2	CAN RPDO Message.....	19
3.5.3	CAN TPDO Message.....	21
3.6	Available Control Sources	22
3.7	Configuration Example.....	24
3.7.1	User Requirements.....	24
3.7.2	Configuration Steps	26
4	Flashing new Firmware	30
5	Installation Instructions	34
5.1	Node ID and Baud rate.....	34
5.1.1	LSS Protocol to Update.....	34
5.1.2	Setting Node-ID	34
5.1.3	Setting Baudrate.....	35
5.2	Communication Objects (DS-301)	38
5.2.1	1000h Device Type	39
5.2.2	1001h Error Register	39
5.2.3	1002h Manufacturer Status Object	39
5.2.4	1003h Pre-Defined Error Field	39
5.2.5	1009h Manufacturer Status Object	39
5.2.6	100Ah Manufacturer Status Object	39
5.2.7	100Ch Manufacturer Status Object	40
5.2.8	100Dh Life Time Factor	40
5.2.9	1010h Store Parameters	40
5.2.10	1011h Restore Parameters	40
5.2.11	1016h Consumer Heartbeat Time	41

5.2.12	1017h Producer Heartbeat Time	41
5.2.13	1018h Identity Object	41
5.2.14	1020h Verify Configuration.....	41
5.2.15	1029h Error Behavior.....	41
5.2.16	1400h RPDO 1 Communication Parameters	42
5.2.17	1401h RPDO 2 Communication Parameters	42
5.2.18	1402h RPDO 3 Communication Parameters	42
5.2.19	1403h RPDO 4 Communication Parameters	42
5.2.20	1600h RPDO 1 Mapping Parameters	43
5.2.21	1601h RPDO 2 Mapping Parameters	43
5.2.22	1602h RPDO 3 Mapping Parameters	43
5.2.23	1603h RPDO 4 Mapping Parameters	44
5.2.24	1800h TPDO 1 Communication Parameters.....	44
5.2.25	1801h TPDO 2 Communication Parameters.....	44
5.2.26	1802h TPDO 3 Communication Parameters.....	44
5.2.27	1803h TPDO 4 Communication Parameters.....	45
5.2.28	1A00h TPDO 1 Mapping Parameters	45
5.2.29	1A01h TPDO 2 Mapping Parameters	45
5.2.30	1A02h TPDO 3 Mapping Parameters	45
5.2.31	1A03h TPDO 4 Mapping Parameters	46
5.3	Manufacturer Objects.....	46
5.3.1	2000h Slew Rate	50
5.3.2	2001h LIN Node Type	50
5.3.3	2002h LIN Baud Rate	50
5.3.4	2003h LIN Tick Time	50
5.3.5	2100h LIN Signal 1 – 2122h LIN Signal 35 Byte Array	50
5.3.6	2130h LIN Signal 1 - 35 Type	50
5.3.7	2131h LIN Signal Source 1 – 35	51
5.3.8	2132h LIN Signal 1 - 35 Autoreset Time	52
5.3.9	2133h LIN Signal 1 – 35 Bit size	53
5.3.10	2134h LIN Signal 1 – 35 Encoding Type	54
5.3.11	2135h LIN Signal 1 – 35 Minimum Value.....	55
5.3.12	2136h LIN Signal 1 – 35 Maximum Value	56
5.3.13	2137h LIN Signal 1 – 35 Scale	57
5.3.14	2138h LIN Signal 1 – 35 Offset.....	59
5.3.15	2139h LIN Signal 1 – 35 Initial value scalar	60
5.3.16	2200h LIN Unconditional Frame 1 – 10 Kind	61
5.3.17	2201h LIN Unconditional Frame 1 – 10 ID.....	62
5.3.18	2202h LIN Unconditional Frame 1 – 10 Associated with event triggered frame.....	62
5.3.19	2203h LIN Unconditional Frame 1 – 10 Size.....	62
5.3.20	2210h LIN Unconditional Frame 1 Number 1 – 10.....	63
5.3.21	2211h LIN Unconditional Frame 1 Offset 1 – 10	63
5.3.22	2220h LIN Unconditional Frame 2 Number 1 – 10.....	63
5.3.23	2221h LIN Unconditional Frame 2 Offset 1 – 10	64
5.3.24	2230h, 2240h, 2250h, 2260h, 2270h, 2280h, 2290h, 22A0h LIN Unconditional Frame 3 – 10 Number 1 – 10	64
5.3.25	2231h, 2241h, 2251h, 2261h, 2271h, 2281h, 2291h, 22A1h LIN Unconditional Frame 3 – 10 Offset 1 – 10	64
5.3.26	2300h LIN Event Triggered Frame Kind	65
5.3.27	2301h LIN Event Triggered Frame ID.....	65

5.3.28	2302h LIN Event Triggered Frame Size	65
5.3.29	2303h LIN Event Triggered Frame Checksum Type.....	65
5.3.30	2304h LIN Event Triggered Frame Collision Resolving Schedule Table Number	65
5.3.31	2310h LIN Event Triggered Frame Unconditional Frame Number	65
5.3.32	2400h LIN Sporadic Frame Kind.....	66
5.3.33	2410h LIN Sporadic Frame Unconditional Frame Number	66
5.3.34	2500h LIN Main Schedule Type	66
5.3.35	2501h LIN Main Schedule Number	66
5.3.36	2502h LIN Main Schedule Delay	67
5.3.37	2600h LIN Collision Schedule Type	67
5.3.38	2601h LIN Collision Schedule Number	67
5.3.39	2602h LIN Collision Schedule Delay.....	67
5.3.40	2700h Global Parameter Continuous Signal.....	68
5.3.41	2701h Global Parameter Discrete Signal.....	68
5.3.42	3010h – 30F0 Binary Function Input Source	68
5.3.43	3011h – 30F1 Binary Function Is Signal Default	68
5.3.44	3012h – 30F2 Binary Function Default Value	68
5.3.45	3013h – 30F3 Binary Function Unary Function	69
5.3.46	3014h – 30F4 Binary Function Scale.....	69
5.3.47	3015h – 30F5 Binary Function Offset	69
5.3.48	300Ah Binary Function Output Operation.....	69
5.3.49	300Bh Binary Function Output Scaling	70
5.3.50	300Ch Binary Function Output Offset	70
5.3.51	4000h Global VPS Data	70
5.3.52	4001h Global Temperature Data	71
5.3.53	4002h LIN Data Data	71
5.3.54	4003h Extra CANopen Data Signal.....	71
5.3.55	4004h LIN Driver Status	72
5.3.56	4005h LIN Driver Slave Error.....	72
5.3.57	5555h Start in Operational Mode.....	72
5.3.58	55AAh Start Bootloader	72
5.3.59	5B50h Change Baud Rate.....	72
5.3.60	5B51h Change Node ID	72
6	TECHNICAL SPECIFICATIONS.....	73
6.1	Power	73
6.2	Control Software	73
6.3	General Specifications	73

1 INTRODUCTION

The following user manual is a description of the architecture, the functionality, the configuration of parameters, and flashing instructions for the LIN – CANopen Protocol Converter. It also contains technical specifications and installation instructions to help users build a custom solution on the base of this converter.

The converter supports LIN and CANopen interfaces. It is assumed, that the user is familiar with LIN Specification Package and CANopen group of standards. The terminology from these standards is widely used in this manual.

The various function blocks supported by the LIN – CANopen converter are outlined in the following sections. All objects are user configurable using standard commercially available tools that can interact with a CANopen® Object Dictionary via an EDS file.

2 CONVERTER DESCRIPTION

The converter is designed to translate application signals between LIN 2.2 and CANopen networks. It can run in LIN master or slave mode at different baud rates from: 2.4 to 20 kbit/s. The CANopen network operates at a standard 125 kbit/s baud rate.

The converter can be configured through a set of configuration parameters to suit the user specific application requirements.

2.1 Hardware Block Diagram

The converter contains: one LIN port, one CAN port and a protected power supply. An embedded 32-bit microcontroller provides necessary processing power to the converter.

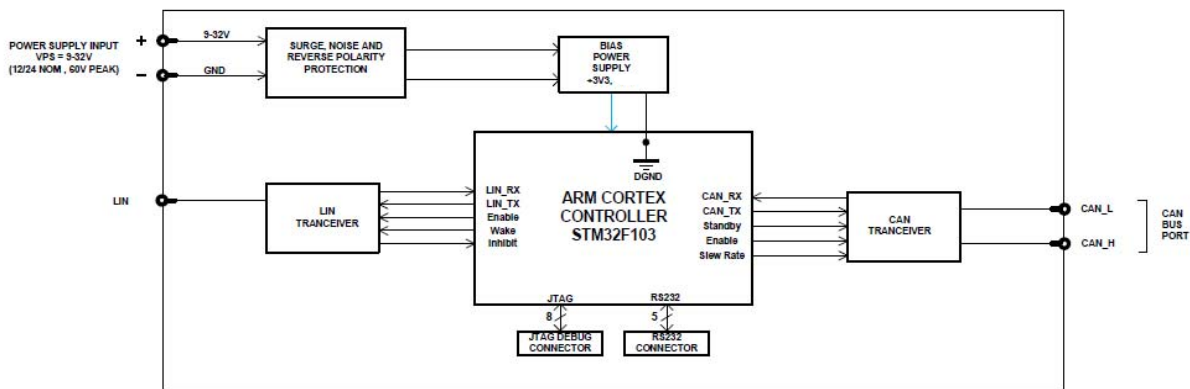

Figure 1. The Converter Hardware Block Diagram

The converter has a wide range of protection features including transient and reverse polarity protections, see [Technical Specifications](#) section.

2.2 LIN Interface

The LIN interface is compliant with the LIN Specification Package, Revision 2.2A, December 31, 2010. The following parts of this standard specification package were implemented:

Table 1. LIN Standard Implementation

ISO/OSI Network Model Layer	LIN Specification Package Document
Physical	Physical Layer Specification.
Data Link	Protocol Specification.
Network	Not Implemented.
Transport	N/A in LIN.
Session	N/A in LIN.
Presentation	N/A in LIN.

ISO/OSI Network Model Layer	LIN Specification Package Document
Application	<p>Application Program Interface Specification.</p> <p>Master and Slave nodes are supported. The user can configure: 35 signals, 10 unconditional frames, 1 event triggered and 1 sporadic frame. One main schedule table and one collision schedule table are also available for master nodes.</p>

3 CONVERTER LOGICAL STRUCTURE

The converter is internally organized as a set of function blocks, which can be individually configured and arbitrarily connected together to achieve the required system functionality, see Figure 2.

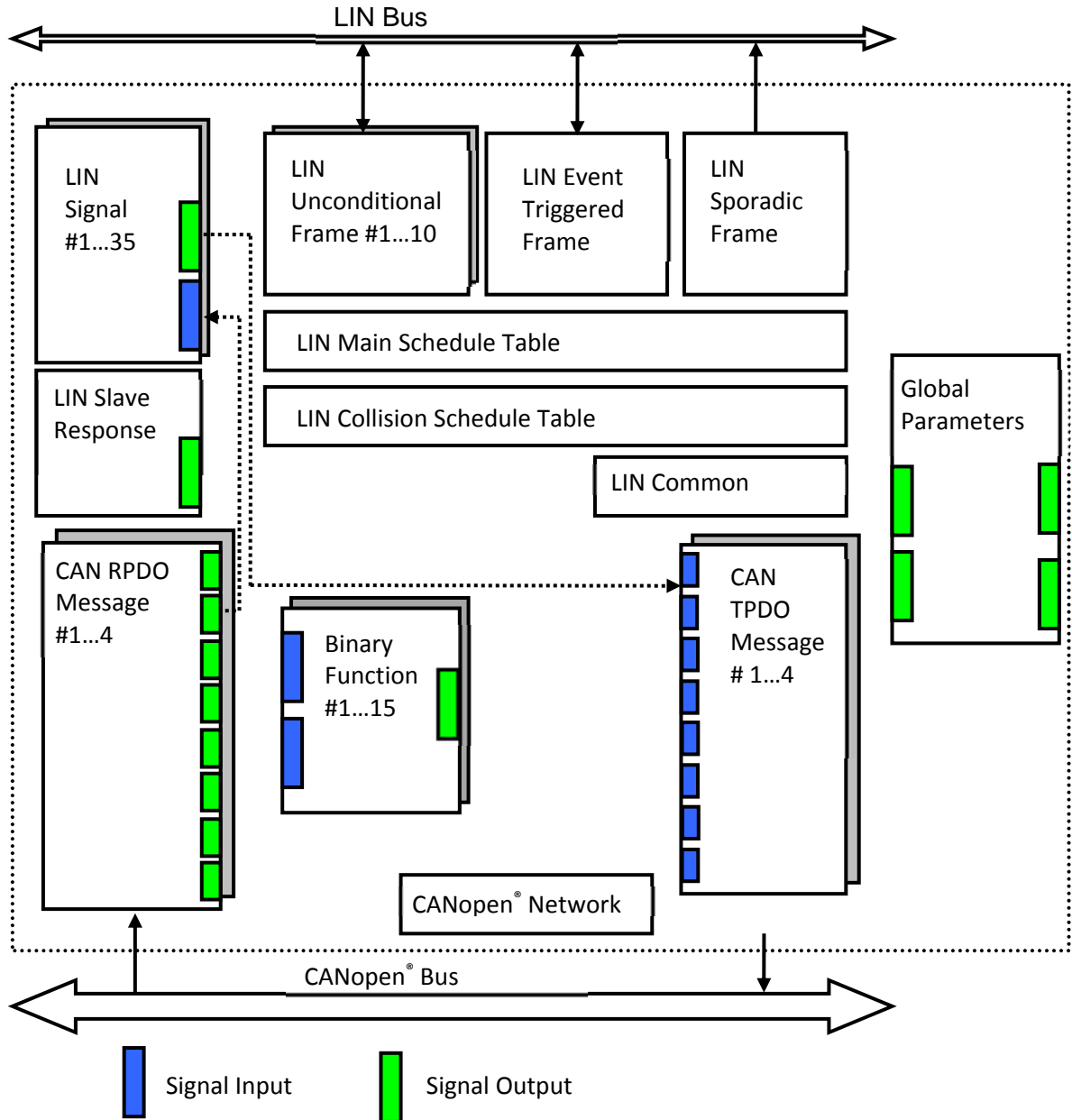

The actual connections between signal inputs and outputs are defined by the configuration parameters.

Figure 2. The Converter Logical Block Diagram

Each function block is independent from each other and each has its own set of configuration parameters or setpoints.

The LIN interface is represented by the LIN Signal function block, while the other LIN function blocks are controlling the sending and receiving of the LIN signals. Each LIN Signal function block provides one signal input and one signal output. When the LIN Signal functional block transmits data on the LIN bus, it reads data from the signal input. When it receives data from the LIN bus, the data is written to the signal output.

CANopen interface is presented by the *RPDO messages* and *TPDO messages*. The *CAN RPDO Message* blocks are used to receive CAN signals transmitted on the CAN bus. They have eight one-byte input signals which are updated once the signal is received. The *CAN TPDO Message* function blocks are used to transmit CAN signals on the CAN bus. Each CAN message can hold up to eight individual one-byte signals which can receive data from up to eight signal inputs.

For data processing, when required, the unit can use *Binary Function* blocks. They take two input signals and combine them together into one signal output using different mathematical and/or logic arguments.

The converter also has a *Global Parameters* function block containing two constant output signals and other auxiliary output signals.

3.1 Function Block Signals

The converter's function blocks can communicate with each other through signal inputs and outputs. Each signal input can be connected to any signal output using an appropriate configuration parameter.

When a signal input is connected to a signal output, data from the signal output of one function block is available on the signal input of another function block.

Depending on the signal type, the function block signal output can be either *Discrete* or *Continuous*. The function block signal input, receiving the output signal, can be: *Undefined*, *Discrete* or *Continuous*.

3.1.1 Undefined Signal

The *Undefined* signal type is used to present a no-signal condition in signal data or to specify that the signal input is not connected (not used).

3.1.2 Discrete Signal

The *Discrete* signal type is used to present a discrete signal that has a finite number of states in signal data or to specify that the signal input or output is communicating this type of signals.

The discrete signals are stored in four-byte unsigned integer variables that can present any state value in the 0...0xFFFFFFFF range.

3.1.3 Continuous Signal

The *Continuous* signal type presents continuous signals, usually physical parameters, in signal data or as a signal input or output type.

The continuous signals are stored in floating point variables. They are not normalized and present data in the appropriate physical units. The user can do simple scaling of the continuous signal data by changing *Scale (Resolution)* and *Offset* configuration parameters in the appropriate function blocks.

3.1.4 Signal Type Conversion

Discrete and *Continuous* signals are automatically converted into each other when a signal input of one signal type is connected to a signal output of a different signal type.

3.1.4.1 Discrete to Continuous Conversion

A *Discrete* signal is converted into a positive *Continuous* signal of the same value.

3.1.4.2 Continuous to Discrete Conversion

A positive *Continuous* signal is converted into the same value *Discrete* signal. A fractional part of the *Continuous* signal is truncated. If the *Continuous* signal value is above the maximum *Discrete* signal value, the resulted *Discrete* signal value will saturate at the maximum *Discrete* signal value: 0xFFFFFFFF.

All negative *Continuous* signals are converted into zero value *Discrete* signals.

3.1.4.3 Undefined Signal Conversion

An *Undefined* signal is not converted into a specific discrete or continuous signal value. It presents a no-signal condition on both: *Discrete* and *Continuous* signal inputs and outputs. The value of an undefined signal is not defined unless a default signal value configuration parameter is used in a function block. In this case, the configuration parameter value is used as a signal value when the signal is not defined, see [Binary Function](#) blocks.

3.2 LIN Interface

The converter LIN interface is defined by: *LIN Signal*, *LIN Unconditional Frame*, *Event Triggered Frame*, *Sporadic Frame*, *Main Schedule Table*, *Collision Schedule Table* and *LIN Common* function blocks.

LIN signals are sent and received through *LIN Signal* function blocks. Other function blocks are used to define the LIN network communication.

The function blocks will be presented in the order they appear in the CANopen Object Directory.

3.2.1 LIN Common

LIN Common function block does not have any signal inputs or outputs.



Figure 3. *LIN Common* Function Block

It defines the high-level LIN bus configuration parameters. See the following table.

Table 2. LIN Common Function Block Configuration Parameters

Name	Default Value	Range	Units	Description
Node Type	Master	{Undefined, Master, Slave}	–	LIN node type. The “Undefined” value is used to switch off the node, for example during debugging.
Baud Rate	10417	[2400...20000]	bit/s	LIN bus baud rate. The minimum baud rate value is limited by the converter transceiver hardware.
Tick Time	10	[1...10000]	ms	Tick time, if Node Type is “Master”.

After changing any LIN based parameter, including the LIN Baud rate, the CANopen manufacturer parameters need to be stored by using index 1010h so that the baud rate stays changed after the next power cycle.

3.2.2 LIN Signal

LIN Signal function blocks are used to specify input and output signals on the LIN bus. There are 35 LIN Signal function blocks available to the user. Each LIN Signal function block has one signal input and one signal output for interfacing with other function blocks.

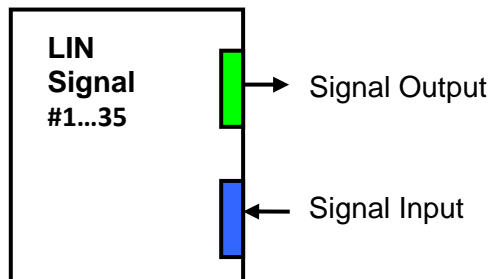

Figure 4. LIN Signal Function Block

Configuration parameters of the LIN Signal function block are presented below:

Table 3. LIN Signal Function Block Configuration Parameters

Name	Default Value ¹	Range	Units	Description
LIN Signal Type	Scalar	{Undefined, Scalar, Byte Array}	–	Type of the LIN signal.
Input Signal Source	CAN Input Signal #1	Any signal output of any function block or “Not Connected”	–	Input signal source if LIN signal is output (data is sent on the LIN bus).
Output Signal Autoreset Time	0	[1...10000]	ms	Autoreset time if LIN signal is input (data is

Name	Default Value ¹	Range	Units	Description
				received from the LIN bus). If 0 – Autoreset is disabled.
Size	8	[1...64]	Bit	Signal size.
Encoding Type	Physical Value	{Undefined, Logical Value, Physical Value, BCD Value, ASCII Value}	–	Type of the LIN signal content.
Min Value	0	[0...0xFFFFFFFF]	–	Min value of the signal code when the Encoding Type is “Logical Value” or “Physical Value”.
Max Value	0xFE	[0...0xFFFFFFFF]	–	Max value of the signal code when the Encoding Type is “Logical Value” or “Physical Value”.
Scale	1	Any value	Signal Units/Bit	Signal scale when the Encoding Type is “Physical Value”.
Offset	0	Any value	Signal Units	Signal offset when the Encoding Type is “Physical Value”.
Init Value Scalar	0x1	[0...0xFFFF]	–	Initial signal value when LIN Signal Type is Scalar.
Init Value Byte Array [0]	0	[0...0xFF]	–	Initial signal value of the 1-st byte when LIN Signal Type is “Byte Array”.
Init Value Byte Array [1]	0	[0...0xFF]	–	Initial signal value of the 2-nd byte when LIN Signal Type is “Byte Array”.
...
Init Value Byte Array [7]	0	[0...0xFF]	–	Initial signal value of the 8-th byte when LIN Signal Type is “Byte Array”.

¹For LIN Signal #1.

Encoding Type configuration parameter defines the function block signal input and output type the following way:

Table 4. LIN Signal Encoding Type

Encoding Type	Function Block Signal Type
Undefined	Undefined
Logical Value	Discrete
Physical Value	Continuous
BCD Value	Discrete
ASCII Value	Discrete

3.2.2.1 Receiving LIN Signals

When the *LIN Signal* function block receives signals from the LIN bus, they are converted to the function block output signal the following way:

- Logical signals are received only when they are within the $[MinValue; MaxValue]$ range. No conversion is performed;
- BCD signals are received unconditionally. No conversion is performed;
- ASCII signals are masked with 0xFF value. This way, only the least significant byte of the input signal is received and passed to the output;
- Physical signals are received only when they are within the $[MinValue; MaxValue]$ range and then converted to the output signal value using *Scale* and *Offset* configuration parameters:

$$LINOutputSignal = LINSignalCode * Scale + Offset, \quad \text{if} \quad (1)$$

$$LINSignalCode \in [MinValue; MaxValue].$$

If the output signal is not updated within the *Output Signal Autoreset Time*, the output signal will be reset to undefined. The auto-reset is disabled when the *Output Signal Autoreset Time* configuration parameter is equal to 0.

The initial value of the *LIN Signal* function block output signal is undefined.

3.2.2.2 Transmitting LIN Signals

When the *LIN Signal* function block transmits signals on the LIN bus, the signal data are acquired from the function block signal input source and processed, before transmission, in a similar way as the incoming LIN signals:

- Logical signals are transmitted only when they are in the $[MinValue; MaxValue]$ range;
- BCD signals are transmitted without any conversion;
- ASCII signals are masked with 0xFF value and then transmitted;
- The physical signals are converted to the LIN signal code using *Scale* and *Offset* configuration parameters and then saturated to the *MinValue* or *MaxValue* if the code goes out of the $[MinValue; MaxValue]$ range.
- Undefined signals are presented by their initial signal values.

3.2.3 LIN Slave Response

There is a special *LIN Slave Response* function block with one output signal.

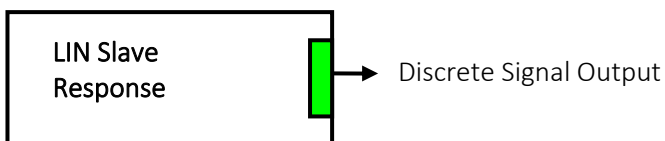

Figure 5. *LIN Slave Response* Function Block

This function block does not have any configuration parameters. It provides a discrete logical output signal reflecting the state of the LIN slave node according to the LIN standard requirements.

In the master mode, this function block is not used, and its output signal is undefined.

3.2.4 LIN Unconditional Frame

There are *10 LIN Unconditional Frame* function blocks available to the user. Each function block represents one LIN frame that can be transmitted or received on the LIN bus.

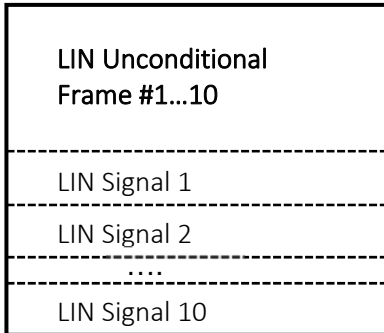

Figure 6. LIN Unconditional Frame Function Block

There are no signal inputs or outputs in this function block; all data is transmitted or received through the associated *LIN Signal* function blocks. There can be up to 10 LIN signals associated with each LIN frame.

Configuration parameters of the *LIN Unconditional Frame* function block are presented below:

Table 5. LIN Unconditional Frame Function Block Configuration Parameters

Name	Default Value ¹	Range	Units	Description
LIN Frame Kind	Publish	{Undefined, Publish, Subscribe}	–	Defines whether the frame is transmitted or received.
Frame ID	0x12	0...0x3F	–	Frame ID.
Associated with Event Triggered Frame	No	{No, Yes}	–	Defines whether this frame is used in the Event Triggered Frame.
Size	4	[1...8]	Byte	Frame Size.
Checksum Type	Enhanced	{Classic, Enhanced}	–	Type of the frame checksum.
Signal #1 Number	1	[0...35]	–	Number of the 1-st <i>LIN Signal</i> function block.
Signal #1 Offset	0	[0...63]	Bit	Offset of the LIN signal defined by the 1-st <i>LIN Signal</i> function block.
Signal #2 Number	2	[0...35]	–	Number of the 2-nd <i>LIN Signal</i> function block.
Signal #2 Offset	8	[0...63]	Bit	Offset of the LIN signal defined by the 2-nd <i>LIN Signal</i> function block.
...

Name	Default Value ¹	Range	Units	Description
Signal #10 Number	0	[0...35]	–	Number of the 10-th <i>LIN Signal</i> function block.
Signal #10 Offset	0	[0...63]	Bit	Offset of the LIN signal defined by the 10-th <i>LIN Signal</i> function block.

¹For *LIN Unconditional Frame #1*.

The *LIN Conditional* function blocks are numbered from 1 to 10. When the *Signal #1...10 Number* is equal to 0, the *LIN Conditional* function block is not defined and the associated *Signal #1...10 Offset* configuration parameter is not used.

3.2.5 LIN Event Triggered Frame

There is one *LIN Event Triggered Frame* function block available to the user. It can contain up to 5 associated LIN frames. There are no signal inputs or outputs in this function block.

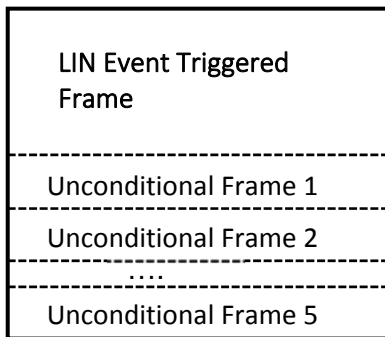

Figure 7. *LIN Event Triggered Frame* Function Block

Configuration parameters of the *LIN Event Triggered Frame* function block are presented below:

Table 6. *LIN Event Triggered Frame* Function Block Configuration Parameters

Name	Default Value	Range	Units	Description
LIN Frame Kind	Undefined	{Undefined, Publish, Subscribe}	–	Defines whether the frame is transmitted or received.
Frame ID	0	0...0x3F	–	Frame ID.
Size	1	[1...8]	Byte	Frame Size.
Checksum Type	Classic	{Classic, Enhanced}	–	Type of the frame checksum.
Collision Resolving Schedule Table Number	0	[0...1]	–	Number of the <i>Collision Resolving Schedule Table</i> function block used in case of a collision.

Name	Default Value	Range	Units	Description
Unconditional Frame #1 Number	0	[0...10]	–	Number of the 1-st <i>LIN Unconditional Frame</i> function block.
Unconditional Frame #2 Number	0	[0...10]	–	Number of the 2-nd <i>LIN Unconditional Frame</i> function block.
...
Unconditional Frame #5 Number	0	[0...10]	–	Number of the 5-th <i>LIN Unconditional Frame</i> function block.

Collision Resolving Schedule Table function blocks are numbered starting from 0. When the *Collision Resolving Schedule Table Number* is equal to 0, the function block is not defined. The same rule applies to the *LIN Unconditional Frame* function blocks.

When the event triggered frame is defined, all associated unconditional frames should have the same frame size and checksum type as defined in the *LIN Event Triggered Frame* function block. They should also have *Associated with Event Triggered Frame* configuration parameter set to Yes.

3.2.6 LIN Sporadic Frame

There is one *LIN Sporadic Frame* function block available to the user. It can contain up to 5 associated LIN frames. There are no signal inputs or outputs in this function block.

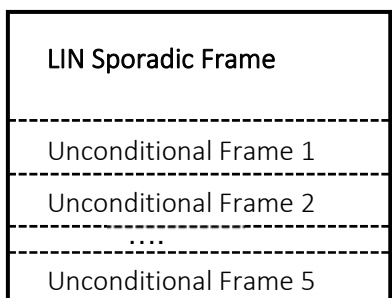

Figure 8. Sporadic Frame Function Block

This block is used only by master nodes. See: *Node Type* configuration parameter in the *LIN Common* function block.

Configuration parameters of the *LIN Sporadic Frame* function block are presented below:

Table 7. *LIN Sporadic Frame* Function Block Configuration Parameters

Name	Default Value	Range	Units	Description
LIN Frame Kind	Publish	{Undefined, Publish, Subscribe}	–	Defines whether the frame is transmitted or received.

Name	Default Value	Range	Units	Description
Unconditional Frame #1 Number	1	[0...10]	–	Number of the 1-st <i>LIN Unconditional Frame</i> function block.
Unconditional Frame #2 Number	0	[0...10]	–	Number of the 2-nd <i>LIN Unconditional Frame</i> function block.
...
Unconditional Frame #5 Number	0	[0...10]	–	Number of the 5-th <i>LIN Unconditional Frame</i> function block.

Sending priorities in the sporadic frame is defined in descending order: unconditional frame #1 has the maximum priority and unconditional frame #5 – minimum. When *Unconditional Frame #1...5 Number* is equal to 0, the frame is undefined.

3.2.7 Main Schedule Table

There is one *Main Schedule Table* function block available to the user. It is used by the master node by default and can contain up to 10 schedule entries. There are no signal inputs and outputs in this function block.

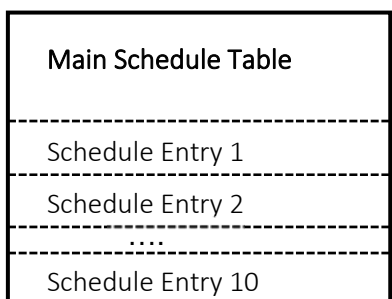

Figure 9. Main Schedule Table Function Block

Configuration parameters of the *Main Schedule Table* function block are presented below:

Table 8. Main Schedule Table Function Block Configuration Parameters

Name	Default Value	Range	Units	Description
Entry #1 Frame Type	Unconditional	{Undefined, Unconditional, Event Triggered, Sporadic}	–	1-st schedule entry frame type.
Entry #1 Frame Number	2	Depends on the frame type	–	1-st schedule entry frame number.
Entry #1 Delay	20	[0...10000]	ms	1-st schedule entry delay.
Entry #2 Frame Type	Unconditional	{Undefined, Unconditional, Event Triggered, Sporadic}	–	2-nd schedule entry frame type.

Name	Default Value	Range	Units	Description
Entry #2 Frame Number	3	Depends on the frame type	–	2-nd schedule entry frame number.
Entry #2 Delay	20	[0...10000]	ms	2-nd schedule entry delay.
...
Entry #10 Frame Type	Undefined	{Undefined, Unconditional, Event Triggered, Sporadic}	–	10-th schedule entry frame type.
Entry #10 Frame Number	0	Depends on the frame type	–	10-th schedule entry frame number.
Entry #10 Delay	0	[0...10000]	ms	10-th schedule entry delay.

When the frame type is undefined, the schedule entry is skipped. When the frame number is equal to 0, the schedule entry is empty. When the schedule table is used, the first schedule entry should be defined.

3.2.8 Collision Schedule Table

There is one *Collision Schedule Table* function block available to the user. It is used by the master node to resolve collisions in the event triggered frames. *Collision Schedule Table* function block has the same structure as the *Main Schedule Table*. The only difference is in the number of the schedule table entries.

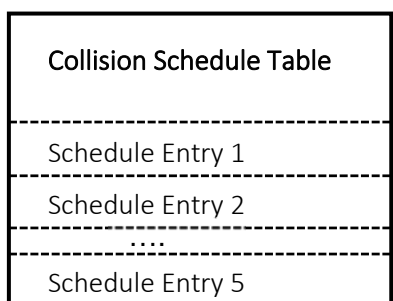

Figure 10. Collision Schedule Table Function Block

The collision schedule table can contain up to 5 schedule entries. The schedule entries follow the same rules defined for the *Main Schedule Table* with the exception that only unconditional frames are allowed in the collision schedule table.

Configuration parameters of the *Collision Schedule Table* function block are presented below:

Table 9. Collision Schedule Table Function Block Configuration Parameters

Name	Default Value	Range	Units	Description
Entry #1 Frame Type	Undefined	{Undefined, Unconditional}	–	1-st schedule entry frame type.

Name	Default Value	Range	Units	Description
Entry #1 Frame Number	0	[0...10]	–	1-st schedule entry frame number.
Entry #1 Delay	0	[0...10000]	ms	1-st schedule entry delay.
Entry #2 Frame Type	Undefined	{Undefined, Unconditional}	–	2-nd schedule entry frame type.
Entry #2 Frame Number	0	[0...10]	–	2-nd schedule entry frame number.
Entry #2 Delay	0	[0...10000]	ms	2-nd schedule entry delay.
...
Entry #5 Frame Type	Undefined	{Undefined, Unconditional}	–	5-th schedule entry frame type.
Entry #5 Frame Number	0	[0...10]	–	5-th schedule entry frame number.
Entry #5 Delay	0	[0...10000]	ms	5-th schedule entry delay.

3.3 Binary Functions

There are fifteen *Binary Function* blocks available to the user for performing simple data conversions. Each *Binary Function* block has two continuous signal inputs and one continuous signal output.

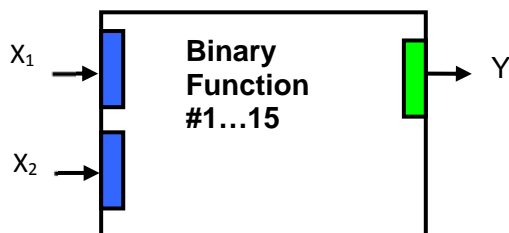

Figure 11. Binary Function Block

The *Binary Function* block performs the following data conversion:

$$Y = A \cdot F[a_1 \cdot f_1(X_1) + b_1; a_2 \cdot f_2(X_2) + b_2] + B, \quad n = 1,2; \quad (2)$$

where:

- X_n – Input signal;
- $f_n(X_n)$ – Unary function;
- a_n – Scale;
- b_n – Offset;
- $F[x; y]$ – Binary Function;
- A – Output Scale;
- B – Output Offset.

The function block input signals can be undefined. The user can specify a default signal value that will be used when the signal is not defined. If the default signal value is not specified, the output signal of the function block will also become undefined.

The following unary functions can be used to process the input signals.

Table 10. Unary Functions

Function Name	Description	Comment
Undefined	$f(x) = x$	Signal is not processed
! Logical Not	$f(x) = !x$	x is converted into 4-byte unsigned integer before function is applied
~ Bitwise Not	$f(x) = \sim x$	x is converted into 4-byte unsigned integer before function is applied
abs(x) Absolute	$f(x) = x, \text{ if } x \geq 0$ $f(x) = -x, \text{ if } x < 0$	

The following binary functions are defined in the function block:

Table 11. Binary Functions

Function Name	Description	Comment
Undefined	$F[x;y] = \text{Undefined}$	Output signal is undefined
+ Addition	$F[x;y] = x + y$	
- Subtraction	$F[x;y] = x - y$	
* Multiplication	$F[x;y] = x * y$	
/ Division	$F[x;y] = x / y$	Division by 0 gives 0
% Modulus	$F[x;y] = x \% y$	x and y are converted into 4-byte unsigned integers before function is applied
max(x,y) Maximum	$F[x;y] = x, \text{ if } x \geq y$ $F[x;y] = y, \text{ if } x < y$	
min(x,y) Minimum	$F[x;y] = x, \text{ if } x \leq y$ $F[x;y] = y, \text{ if } x > y$	
== Equal	$F[x;y] = 1, \text{ if } x = y$ $F[x;y] = 0, \text{ if } x \neq y$	
!= Not Equal	$F[x;y] = 1, \text{ if } x \neq y$ $F[x;y] = 0, \text{ if } x = y$	
> Great	$F[x;y] = 1, \text{ if } x > y$ $F[x;y] = 0, \text{ if } x \leq y$	
>= Great Equal	$F[x;y] = 1, \text{ if } x \geq y$ $F[x;y] = 0, \text{ if } x < y$	
< Less	$F[x;y] = 1, \text{ if } x < y$ $F[x;y] = 0, \text{ if } x \geq y$	
<= Less Equal	$F[x;y] = 1, \text{ if } x \leq y$ $F[x;y] = 0, \text{ if } x > y$	
Logical OR	$F[x;y] = x \vee y$	x and y are converted into 4-byte unsigned integers before function is applied
&& Logical AND	$F[x;y] = x \wedge y$	x and y are converted into 4-byte unsigned integers before function is applied

Function Name	Description	Comment
Bitwise OR	$F[x;y] = x y$	x and y are converted into 4-byte unsigned integers before function is applied
& Bitwise AND	$F[x;y] = x \& y$	x and y are converted into 4-byte unsigned integers before function is applied
^ Bitwise XOR	$F[x;y] = x \wedge y$	x and y are converted into 4-byte unsigned integers before function is applied
<< Left Shift	$F[x;y] = x \ll y$	x and y are converted into 4-byte unsigned integers before function is applied
>> Right Shift	$F[x;y] = x \gg y$	x and y are converted into 4-byte unsigned integers before function is applied

The *Binary Function* has the following set of configuration parameters:

Table 12. Binary Function Block Configuration Parameters

Name	Default Value	Range	Units	Description
Binary Function	Undefined	See Binary Function table	–	$F[x;y]$ – Binary function
Output Scale	1	Any value	–	A – Output Scale
Output Offset	0	Any value	–	B – Output Offset
Input #1 Signal Source	Not Connected	Any signal output of any function block or “Not Connected”	–	X_1 – Input Signal #1
Input #1 Signal Default	No	{No, Yes}	–	Defines whether the default signal value for X_1 is defined.
Input #1 Signal Default Value	0	Any value	–	X_1 default value, if <i>Input #1 Signal Default</i> is Yes.
Unary Function #1	Undefined	See Unary Function table	–	$f_1(x)$ – Unary function #1
Scale #1	1	Any value	–	a_1 – Scale #1
Offset #1	0	Any value	–	b_1 – Offset #1
Input #2 Signal Source	Not Connected	Any signal output of any function block or “Not Connected”	–	X_2 – Input Signal #2
Input #2 Signal Default	No	{No, Yes}	–	Defines whether the default signal value for X_2 is defined.
Input #2 Signal Default Value	0	Any value	–	X_2 default value, if <i>Input #2 Signal Default</i> is Yes.
Unary Function #2	Undefined	See Unary Function table	–	$f_2(x)$ – Unary function #2
Scale #2	1	Any value	–	a_2 – Scale #2
Offset #2	0	Any value	–	b_2 – Offset #2

3.4 Global Parameters

The *Global Parameters* function block gives the user access to the converter supply voltage and the microcontroller internal temperature as well as to a set of two constant output signals. The constant output signals – one discrete and one continuous – can be used by other function blocks for debugging and any other purposes.

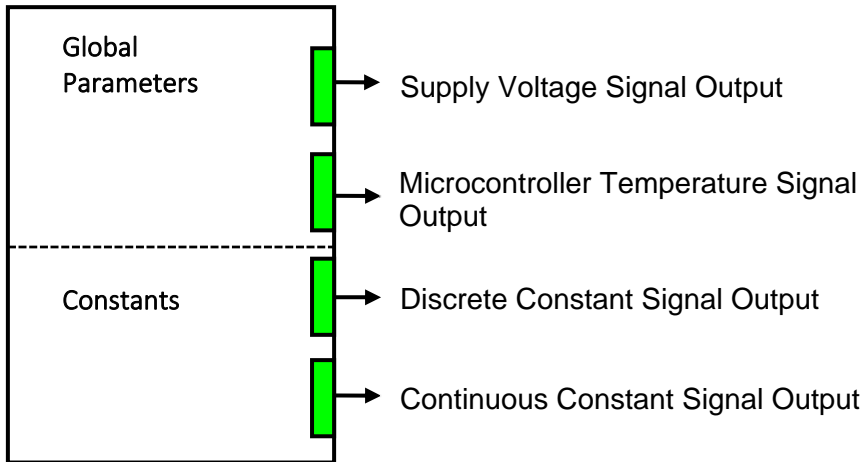

Figure 12. Global Parameters Function Block

Configuration parameters of the *Collision Schedule Table* function block are presented below:

Table 13. Global Parameters Function Block Configuration Parameters

Name	Default Value	Range	Units	Description
Global Continuous Constant Signal	0	Any value	–	Continuous constant signal.
Global Discrete Constant Signal	0	[0... 4294967295 (0xFFFFFFFF)]	–	Discrete constant signal.

3.5 CAN Interface

The converter CAN interface functionality is defined by: *CANopen Network*, *CAN RPDO Message*, *CAN TPDO Message* function blocks.

CAN signals are received from the CAN bus by an RPDO message. CAN signals are transmitted on the CAN bus in a TPDO message defined by the *CAN Output Message* function blocks. The *CANopen* function block contains the global CAN bus configuration settings.

3.5.1 CANopen Network

The *CANopen Network* function block defines the global CANopen bus settings. It does not have signal inputs or outputs.

CANopen Network

Figure 13. CANopen Network Function Block

Configuration parameters of the *CANopen Network* function block are presented below:

Table 14. CANopen Network Function Block Configuration Parameters

Name	Default Value	Range	Units	Description
Start in Operation Mode	0	[0...1]	–	
Start Bootloader	0	[0...1]	–	
Baud rate	125	[1...9]	-	(1=10, 2=20, 3=50, 4=100, 5=125, 6=250, 7=500, 8=800, 9=1000) k/Bits
Node ID	80	[0...127]	–	
Slew Rate	Low	{Low, High}	–	Slew rate control of the CAN transceiver.

By default, the unit will be in *Pre-Operational Mode* after the initialization is finished. In case the parameter *Start in Operational Mode* is set to *TRUE*, the unit will be in *Operational Mode* after the initialization.

Start Bootloader sets the unit to *Bootloader Mode*. This is needed if a firmware update is required. When this value is changed to '1', the unit will start in Bootloader Mode after five seconds. The steps to download new firmware are explained in more detail in chapter **Error! Reference source not found..**

If a different Baud rate or Node ID is required, the parameters *Baud rate* and *Node ID* can be used, as shown in 5.1.

The *Slew Rate* configuration parameter defines the slew rate of the CAN transceiver as follows:

Table 15. CAN Transceiver Slew Rate

Slew Rate Value	Transceiver Slew Rate
Fast	19 V/μs
Slow	4 V/ μs

For the majority of CANopen 125kbit/s applications the slow slew rate is preferable due to the reduced EMI of the transceiver. The fast slew rate is necessary when the distance between nodes substantially exceeds the 40 m standard maximum value, or when the baud rate exceeds 250 kb/s.

3.5.2 CAN RPDO Message

There are 4 *RPDOs* available to the user and each of them can contain up to 8 bytes per message. All four message blocks represent *RPDOs* that can be received from the CAN bus. The function block can

have up to eight signal outputs.

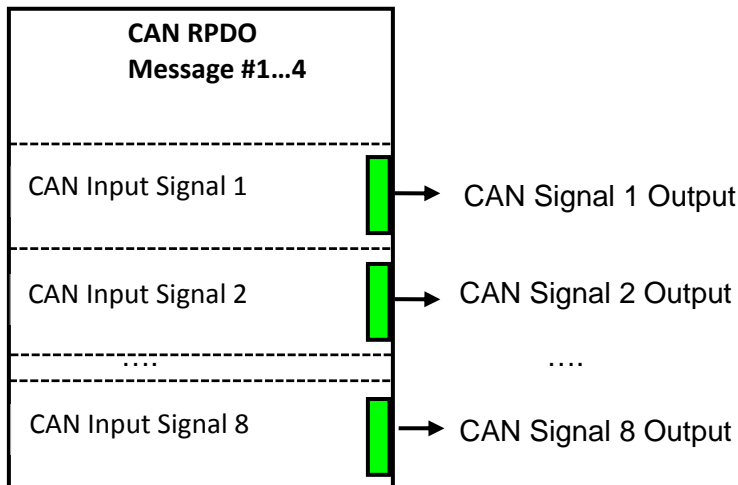

Figure 14. CAN Input Signal Function Block

The *RPDO* function block reads up to eight one-byte signals and extracts the CAN signal data into the user-defined variable by setting a specific entry at the mapping parameters. Different *RPDO* function blocks can read and process the same CAN message to extract different CAN signal data.

Communication parameters of the *CAN Input Signal* function block are presented below:

Table 16. CAN RPDO Function Block Communication Parameters

Name	Default Value ¹	Range	Units	Description
COB ID	0x40000250	0x0-0xFFFFFFFF	–	
Transmission Type	0xFF	0x-0xFF	–	
Inhibit Time	0x0	0-65535	ms	
Compatibility Entry	0x0	0x-0xFF	–	
Event Timer	0x0	0-65535	ms	CAN receive time out

¹Valid for *RPDO* #1.

If the parameter *Event Timer* is set higher or equal to 1, the *RPDO* will timeout after this amount of time if no further CAN message is received within this time window and an error will be flagged. The error behavior can be set via index 1029h Error Behavior.

Mapping parameters of the *RPDO* function block are presented below:

Table 17: CAN RPDO Function Block Mapping Parameters

Name	Default Value ¹	Range	Units	Description
Number of Active <i>RPDO</i> s	8	0-8	–	This parameter decides how many <i>RPDO</i> signals getting received.

Name	Default Value ¹	Range	Units	Description
RPDO Signal 1	0x40020508	0x-0xFFFFFFFF	–	
RPDO Signal 2	0x40020608	0x-0xFFFFFFFF		
RPDO Signal 3	0x40020708	0x-0xFFFFFFFF	–	
RPDO Signal 4	0x40020808	0x-0xFFFFFFFF		
RPDO Signal 5	0x40020908	0x-0xFFFFFFFF		
RPDO Signal 6	0x40020108	0x-0xFFFFFFFF		
RPDO Signal 7	0x40020208	0x-0xFFFFFFFF		
RPDO Signal 8	0x40020308	0x-0xFFFFFFFF		

¹Valid for RPDO #1.

3.5.3 CAN TPDO Message

There are 4 CAN RPDO Message function blocks available to the user. Each function block represents one single frame CAN output message that can be sent on the CAN bus. The message can contain up to 8 one-byte CAN output signals. Each CAN output signal is presented by its function block signal input.

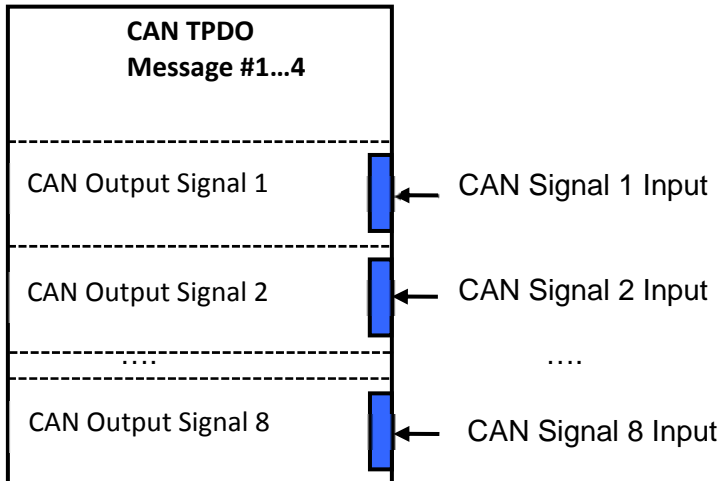

Figure 15. CAN Output Message Function Block

Communication parameters of the CAN Input Signal function block are presented below:

Table 18. CAN RPDO Function Block Communication Parameters

Name	Default Value ¹	Range	Units	Description
COB ID	0x400001D0	0x0-0xFFFFFFFF	–	

Name	Default Value ¹	Range	Units	Description
Transmission Type	0xFE	0x-0xFF	–	
Inhibit Time	0x0	0-65535	ms	
Compatibility Entry	0x0	0x-0xFF	–	
Event Timer	1000	0-65535	ms	CAN transmit repetition rate

¹Valid for TPDO #1.

The *Event Timer* represents the repetition rate of the transmitted CAN data. By setting this parameter to 1000, for instance, each second, the TPDO will be sent.

Mapping parameters of the *TPDO Message* function block are presented below:

Table 19: CAN TPDO Function Block Mapping Parameters

Name	Default Value ¹	Range	Units	Description
Number of Active TPDOs	8	0-8	–	This parameter decides how many TPDO signals are transmitted.
TPDO Signal 1	0x40020508	0x-0xFFFFFFFF	–	
TPDO Signal 2	0x40020608	0x-0xFFFFFFFF		
TPDO Signal 3	0x40020708	0x-0xFFFFFFFF	–	
TPDO Signal 4	0x40020808	0x-0xFFFFFFFF		
TPDO Signal 5	0x40020908	0x-0xFFFFFFFF		
TPDO Signal 6	0x40020108	0x-0xFFFFFFFF		
TPDO Signal 7	0x40020208	0x-0xFFFFFFFF		
TPDO Signal 8	0x40030208	0x-0xFFFFFFFF		

¹Valid for RPDO #1.

3.6 Available Control Sources

Many of the function blocks have selectable input signals, which are determined with *Source* setpoints. This setpoint uniquely select how the I/O of the various function blocks are linked together. Available Source options are listed in Table 20. All sources are available for all blocks. Though input Sources are freely selectable, it must be remembered that not all options would make sense in all cases, and it is up to the user to configure the controller in a logical and functional manner.

Table 20 – Available Control Sources

Sources	Number
<i>Control Not Used</i>	0
<i>LIN Signal 1</i>	1
<i>LIN Signal 2</i>	2
<i>LIN Signal 3</i>	3
<i>LIN Signal 4</i>	4
<i>LIN Signal 5</i>	5
<i>LIN Signal 6</i>	6
<i>LIN Signal 7</i>	7
<i>LIN Signal 8</i>	8
<i>LIN Signal 9</i>	9
<i>LIN Signal 10</i>	10
<i>LIN Signal 11</i>	11
<i>LIN Signal 12</i>	12
<i>LIN Signal 13</i>	13
<i>LIN Signal 14</i>	14
<i>LIN Signal 15</i>	15
<i>LIN Signal 16</i>	16
<i>LIN Signal 17</i>	17
<i>LIN Signal 18</i>	18
<i>LIN Signal 19</i>	19
<i>LIN Signal 20</i>	20
<i>LIN Signal 21</i>	21
<i>LIN Signal 22</i>	22
<i>LIN Signal 23</i>	23
<i>LIN Signal 24</i>	24
<i>LIN Signal 25</i>	25
<i>LIN Signal 26</i>	26
<i>LIN Signal 27</i>	27
<i>LIN Signal 28</i>	28
<i>LIN Signal 29</i>	29
<i>LIN Signal 30</i>	30
<i>LIN Signal 31</i>	31
<i>LIN Signal 32</i>	32
<i>LIN Signal 33</i>	33
<i>LIN Signal 34</i>	34
<i>LIN Signal 35</i>	35
<i>CAN message 1</i>	36
<i>CAN message 2</i>	37
<i>CAN message 3</i>	38
<i>CAN message 4</i>	39
<i>CAN message 5</i>	40

<i>Global constant discrete Signal</i>	41
<i>Global constant continuous Signal</i>	42
<i>Global Voltage Supply value</i>	43
<i>Global Temperature value</i>	44
<i>Binary Function 1</i>	45
<i>Binary Function 2</i>	46
<i>Binary Function 3</i>	47
<i>Binary Function 4</i>	48
<i>Binary Function 5</i>	49
<i>Binary Function 6</i>	50
<i>Binary Function 7</i>	51
<i>Binary Function 8</i>	52
<i>Binary Function 9</i>	53
<i>Binary Function 10</i>	54
<i>Binary Function 11</i>	55
<i>Binary Function 12</i>	56
<i>Binary Function 13</i>	57
<i>Binary Function 14</i>	58
<i>Binary Function 15</i>	59

3.7 Configuration Example

A detailed description of the converter's configuration process is presented in the below subsections. This example is set by default in the firmware.

3.7.1 User Requirements

Let the converter be used to control the Microchip Technology's Interior Ambient Lighting Module with LIN interface, part number: APGRD004.

The CAN bus will carry a message controlling light intensity of the red, green and blue components of the module LED. Ramp up and dim out features will not be used. The LED control message will control all ambient lighting modules on the LIN bus in all lighting zones.

The module LED should be switched off when the LED control CAN message is not available due to loss of CAN communication, etc.

3.7.1.1 LIN Bus

The module is designed to work on a LIN bus at a standard baud rate of 10417 bit/sec, defined in SAE J2602.

The light intensity command frame has the following format:

Frame ID: 0x23

Data Length: 5 byte
Checksum: Standard

Start Position	Length	Signal Name
0	5 bit	SelectIntensity
5	1 bit	Reserved (should be 0)
6	1 bit	RampUp
7	1 bit	DimDown
8	8 bit	RedSaturation
16	8 bit	GreenSaturation
24	8 bit	BlueSaturation
32	4 bit	ZoneSelection
36	4 bit	Reserved (should be 0)

Signal Name: SelectIntensity
Init Value: 0x1F
Range: 0...0x1F (0 – off, 0x1F – maximum intensity)

Signal Name: RampUp
Init Value: 0
Range: 0...1 (0 – no ramp, 1 – ramp up)

Signal Name: DimDown
Init Value: 0
Range: 0...1 (0 – no dim, 1 – dim out)

Signal Name: RedSaturation, GreenSaturation, BlueSaturation
Init Value: 0
Range: 0...0xFF (0 – off, 0xFF – maximum intensity)

Signal Name: ZoneSelection
Init Value: 0x0F
Range: 0...0x0F (0 – no zones, ..., 0x0F – all zones)

For more information on the LIN interface, see: “Interior Ambient Lighting Module with LIN Interface User’s Guide. Microchip Technology Inc., 2008.”

3.7.1.2 CAN bus

A dedicated CANopen proprietary message with the following parameters will be used to control the light intensity of the red, green and blue components of the module LED:

Transmission Repetition Rate: 1.0 sec
Data Length: 8

Start Position	Length	Parameter Name
1	1 byte	IntensityRed

Start Position	Length	Parameter Name
2	1 byte	IntensityGreen
3	1 byte	IntensityBlue

Parameter Name: IntensityRed, IntensityGreen, IntensityBlue
 Data Length: 1 byte
 Resolution: 0.4 %/bit
 Offset: 0
 Type: Measured

3.7.2 Configuration Steps

Since the unit is already set up, this is an overview of what needs to be configured to start the converter. As a first step, a block diagram needs to be created of the required converter configuration using the converter's function blocks. Then, each function block is to be configured individually. Figure 16 demonstrates necessary blocks.

Starting from the LIN signals, the LIN Signal needs to be configured, containing: SelectIntensity, RampUp, and DimDown as *LIN Signal #1*. The *Signal Type* is set to "Scalar", *Size* to 8 bit, *Encoding Type* to "Physical Value" and *Init Value Scalar* to 0x1. This LIN Signal has "LIN Signal #5" as source, since the mapping parameter of RPDO1 subindex 1 is set to 0x40020508.

LIN Signal #2 as RedSaturation signal. This signal will have "LIN Signal #6" as *Input Signal Source* and "Physical Value" as *Encoding Type*. *Min Value*, *Max Value*, *Scale* and *Offset* will be set to convert 0...100% physical value to 0x00...0xFE LIN signal range:

```

MinValue   = 0;
MaxValue   = 0xFE;
Offset     = 0 [%];
Scale      = 100%/0xFF=0.3922 [%/Bit]
  
```

LIN Signal #3 and *LIN Signal #4* are configured in a similar way as GreenSaturation and BlueSaturation signals.

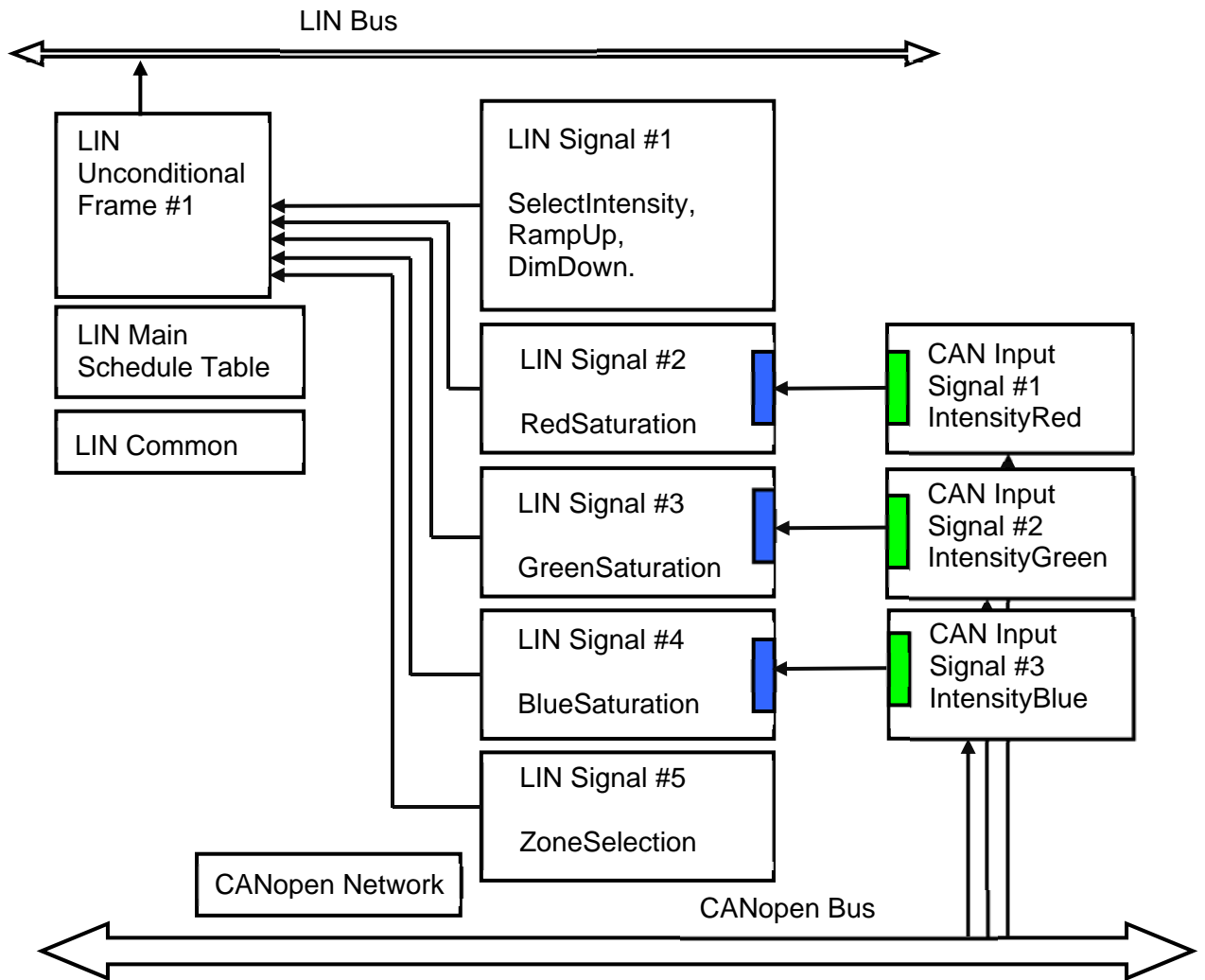

Figure 16. Block Diagram of the Example Converter Configuration

The following steps describe how to control the physical LED using CAN Assistant – Scope.

1. Set the unit into operational mode with the message below:

ID	Len	D0	D1	D2	D3	D4	D5	D6	D7
0000	2	01	00						

If everything is correct, CAN messages should be received and seen in the CAN-scope as shown below:

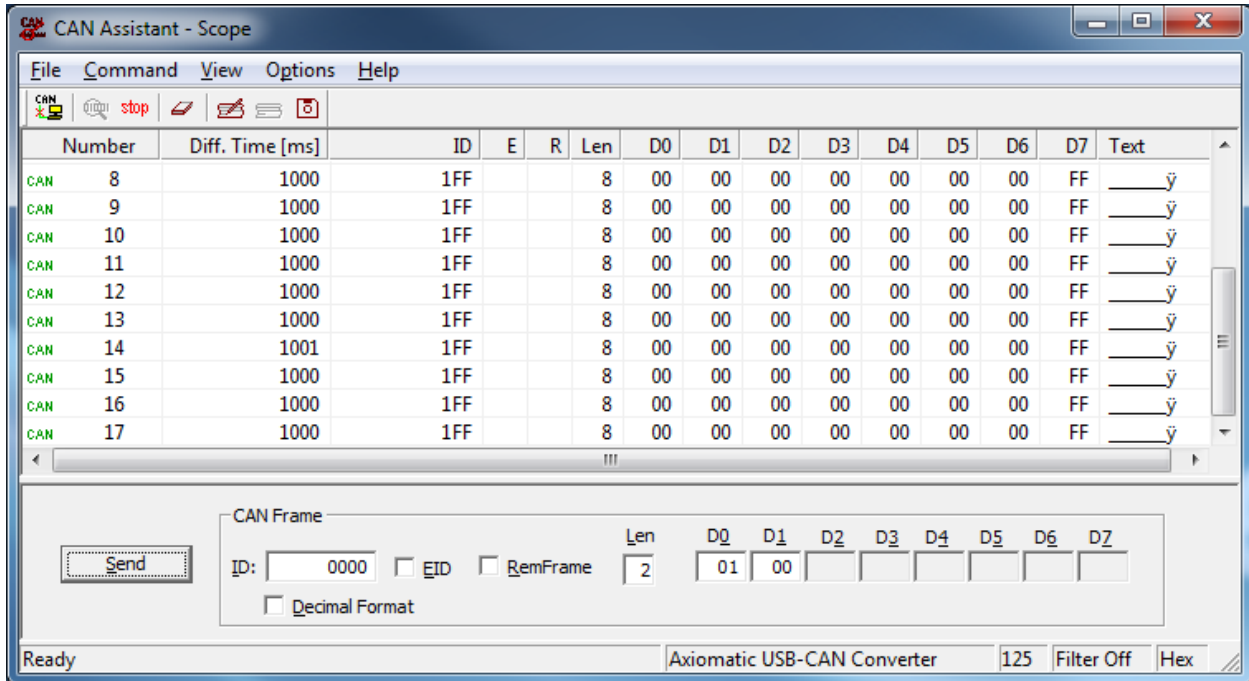

2. Configure the LIN Common function block (index 2001h, 2002h, 2003h) to start the LIN bus communication. This can be done by sending a CAN message, for example, to the index 2002h as following:

Note: Depending on the application, the LIN communication need to be initialized. This can be done by setting the LIN Baud Rate to 10417, for example, with the message below:

ID	Len	D0	D1	D2	D3	D4	D5	D6	D7
67F	8	2B	02	20	00	B1	28	00	00

Afterwards, the LIN communication should be running.

3. By sending the CAN message below, the LED should turn on.

ID	Len	D0	D1	D2	D3	D4	D5	D6	D7
27F	8	08	FE	FE	FE	0F	01	02	03

CAN – Scope should look like demonstrated below

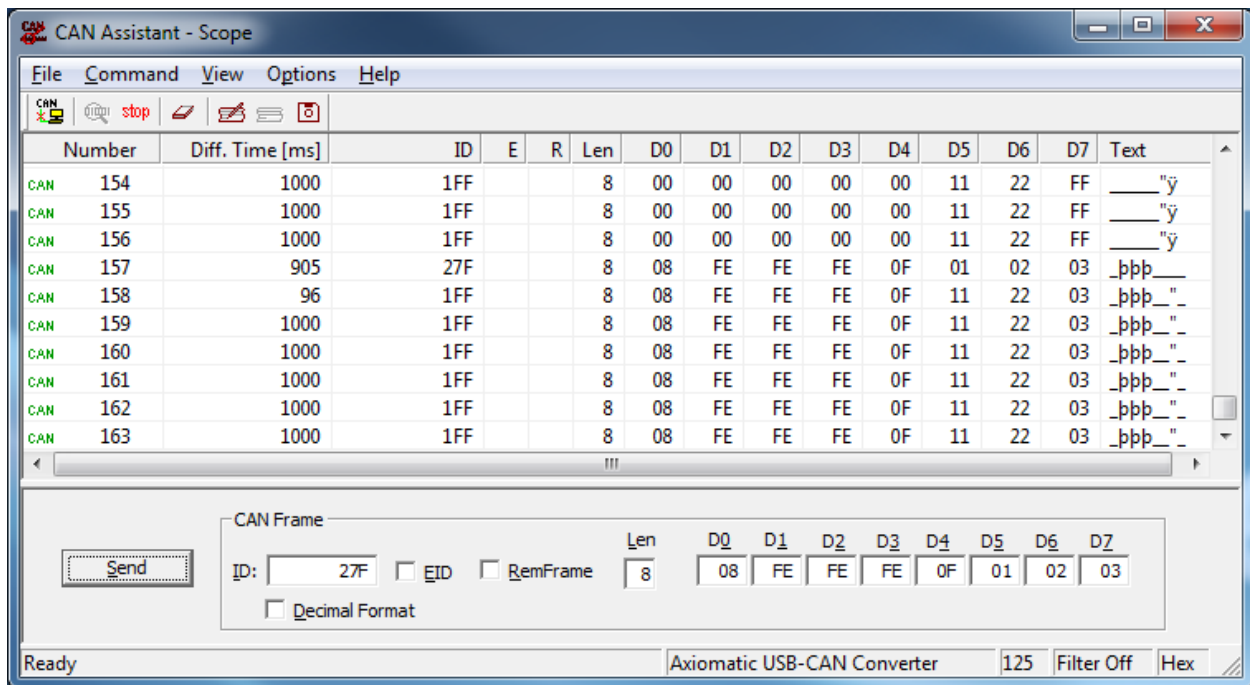

4 Flashing new Firmware

This chapter describes a step by step procedure to flash a new application firmware in the field using the unit's embedded bootloader. First, the prerequisites to set up the process are listed below:

- A personal computer with a USB port running Windows operating system.
- A flash file for AX140603, which should have the following name convention: AF-140603-xx.xx-sss.bin, where xx.xx describes the firmware version number, and sss are file comments for information purposes.
- Axiomatic Electronic Assistant (EA) software, p/n AX070500.
- Axiomatic CAN Assistant – Scope software, p/n AX070501SCO.
- Axiomatic USB-CAN Converter, p/n AX070501. It should be connected to the USB port of the personal computer.
- Power supply to power the converter.
- Wire harness to connect the converter to the power supply and to the CAN port of the Axiomatic USB-CAN converter with the proper termination resistance.

Next, the procedure itself will be shown step by step by enumeration.

1. Connect the unit, AX140603, to the power supply and Axiomatic USB-CAN converter.
2. Open CAN port and start monitoring the CAN bus in CAN Assistant – Scope. Make sure that the baud rate is set to **125 kBit/s**.
3. Power-up the converter. The user should see a single boot-up message from the converter:

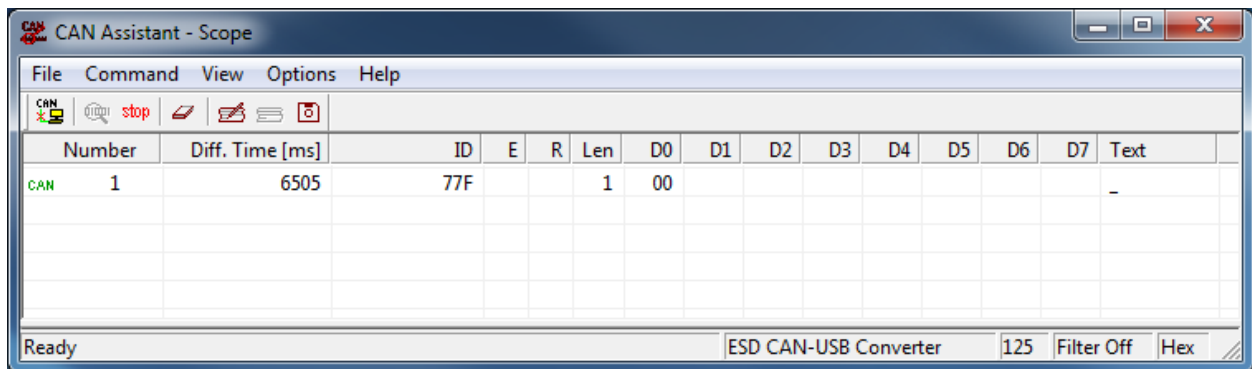

4. Set the CANopen object 0x55AA to 1 using SDO protocol. To do so, send the following message using CAN Assistant – Scope:

ID	Len	D0	D1	D2	D3	D4	D5	D6	D7
67F	8	2F	AA	55	00	01	00	00	00

If everything is correct, the converter acknowledges the writing operation and activates the bootloader after 5 seconds after the message is sent.

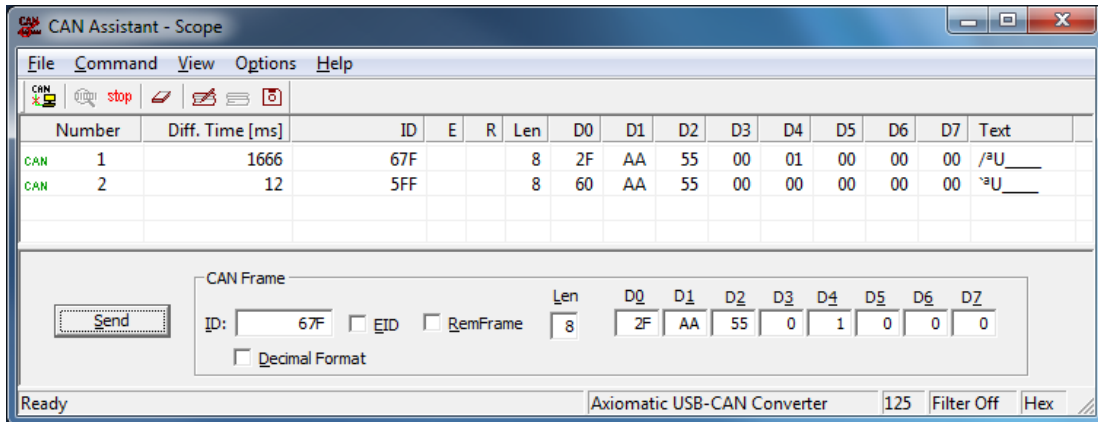

- Run the Electronic Assistant (EA) software and connect to the CAN network. Make sure that under Options -> CAN Interface Setup, the Baud Rate is set to 250 kbit/s. The user should see the following screen with these settings:

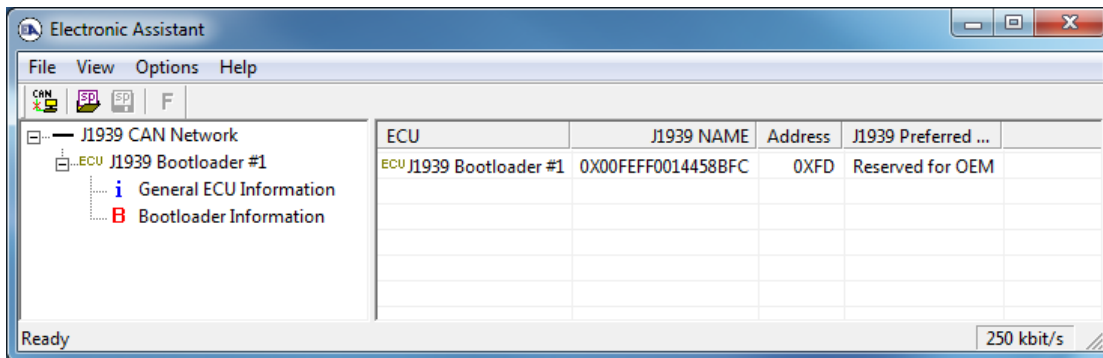

- Click on the *Bootloader Information* group in the left pane and then on the **F** button in the EA toolbar. Select the flash file and click the 'open' button:

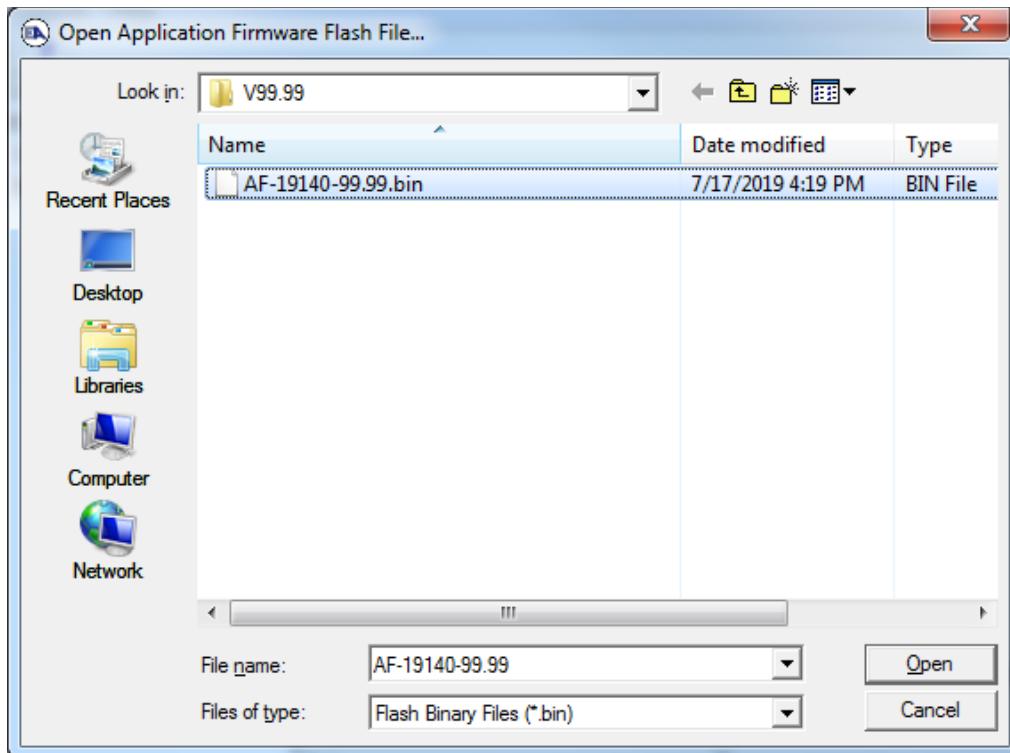

7. Open the flash file and start flashing operation by pressing the *Flash ECU* button.

Note: The erase all ECU Flash Memory option will erase the converted configuration and will set all parameters to default of the new firmware file. If unaware, please contact Axiomatic Technologies.

Optionally, the user can write their comments in the *Flashing Comments* field.

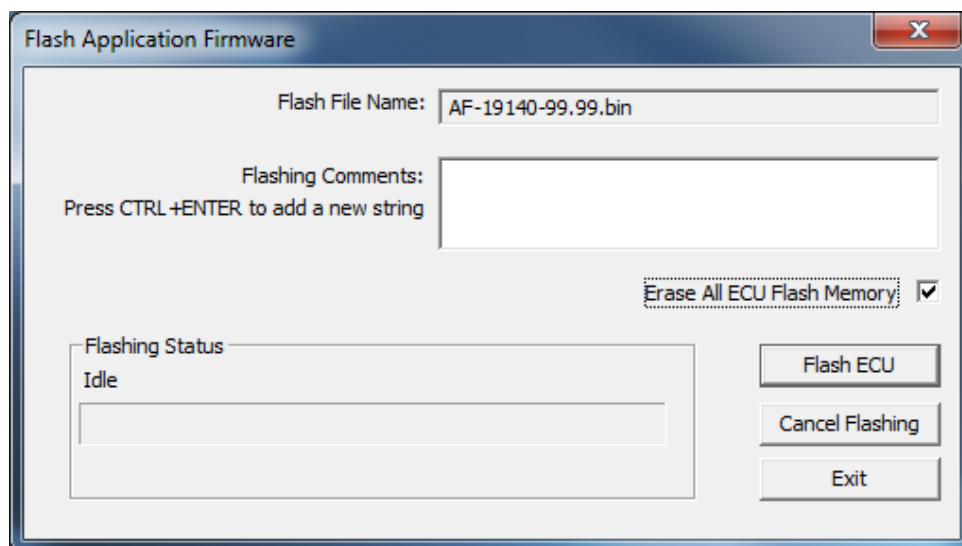

8. Confirm the warning message from EA.

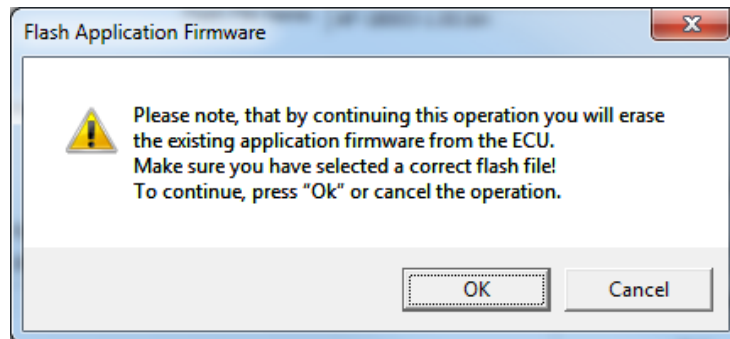

After confirming flashing, the user will see the flashing operation in dynamics on the EA screen

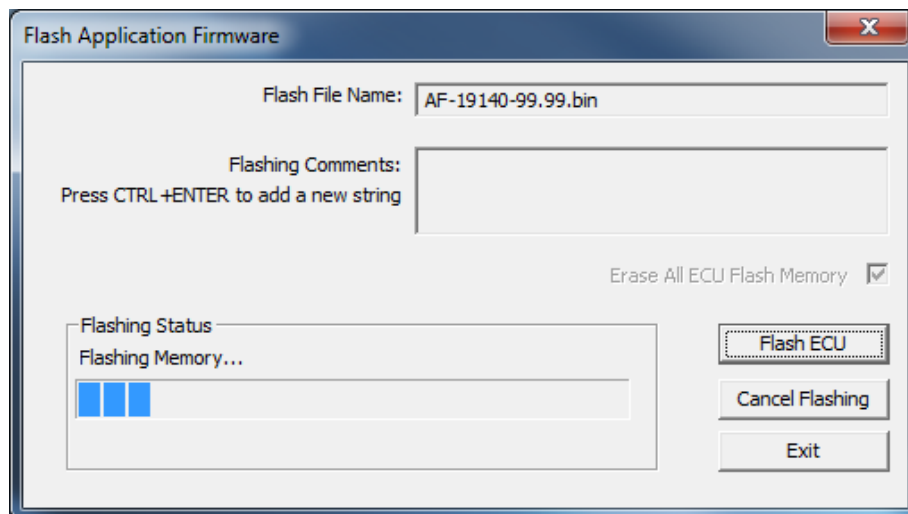

9. When flashing is done, reset the ECU.

After ECU is reset, the J1939 bootloader is no longer active, and the new CANopen application firmware should be running.

10. Check the new application firmware. Cycle the power to the controller. In the CAN Assistant – Scope the user should see a single message from the new application firmware reporting that the unit is in the operational mode.

11. End of procedure.

5 Installation Instructions

The CANopen[®] object dictionary of the AX140603 Controller is based on CiA device profile DS-402 V4.1.0. The object dictionary includes Communication Objects beyond the minimum requirements in the profile, as well as several manufacturer-specific objects for extended functionality.

5.1 Node ID and Baud rate

By default, the AX140603 controller ships factory programmed with a

Node ID = 127 (0x7F)

and with

Baud rate = 125 kbps.

5.1.1 LSS Protocol to Update

The only means by which the Node-ID and Baudrate can be changed is to use Layer Settling Services (LSS) and protocols as defined by CANopen[®] standard DS-305.

Follow the steps below to configure either variable using LSS protocol. If required, please refer to the standard for more detailed information about how to use the protocol

5.1.2 Setting Node-ID

- Set the module state to LSS-configuration by **sending** the following message:

<i>Item</i>	<i>Value</i>
COB-ID	0x7E5
Length	2
Data 0	0x04 (cs=4 for switch state global)
Data 1	0x01 (switches to configuration state)

- Set the Node-ID by **sending** the following message:

<i>Item</i>	<i>Value</i>
COB-ID	0x7E5
Length	2
Data 0	0x11 (cs=17 for configure node-id)

Data 1	Node-ID (set new Node-ID as a hexadecimal number)
--------	---

- The module will send the following response (any other response is a failure).

<i>Item</i>	<i>Value</i>
COB-ID	0x7E4
Length	3
Data 0	0x11 (cs=17 for configure node-id)
Data 1	0x00
Data 2	0x00

- Save the configuration by **sending** the following message:

<i>Item</i>	<i>Value</i>
COB-ID	0x7E5
Length	1
Data 0	0x17 (cs=23 for store configuration)

- The module will send the following response (any other response is a failure)

<i>Item</i>	<i>Value</i>
COB-ID	0x7E4
Length	3
Data 0	0x17 (cs=23 for store configuration)
Data 1	0x00
Data 2	0x00

- Set the module state to LSS-operation by **sending** the following message: (Note, the module will reset itself back to the pre-operational state)

<i>Item</i>	<i>Value</i>
COB-ID	0x7E5
Length	2
Data 0	0x04 (cs=4 for switch state global)
Data 1	0x00 (switches to waiting state)

5.1.3 Setting Baudrate

- Set the module state to LSS-configuration by sending the following message:

<i>Item</i>	<i>Value</i>
COB-ID	0x7E5
Length	2
Data 0	0x04 (cs=4 for switch state global)

Data 1	0x01	(switches to configuration state)
--------	------	-----------------------------------

- Set the baudrate by sending the following message:

<i>Item</i>	<i>Value</i>
COB-ID	0x7E5
Length	3
Data 0	0x13 (cs=19 for configure bit timing parameters)
Data 1	0x00 (switches to waiting state)
Data 2	Index (select baudrate index per Table 32)

Table 21 – LSS Baudrate Indices

<i>Index</i>	<i>Bit Rate</i>
0	1 Mbit/s
1	800 kbit/s
2	500 kbit/s
3	250 kbit/s
4	125 kbit/s (default)
5	reserved (100 kbit/s)
6	50 kbit/s
7	20 kbit/s
8	10 kbit/s

- The module will send the following response (any other response is a failure):

<i>Item</i>	<i>Value</i>
COB-ID	0x7E4
Length	3
Data 0	0x13 (cs=19 for configure bit timing parameters)
Data 1	0x00
Data 2	0x00

- Activate bit timing parameters by sending the following message:

<i>Item</i>	<i>Value</i>
COB-ID	0x7E5
Length	3
Data 0	0x15 (cs=19 for activate bit timing parameters)
Data 1	<delay_lsb>
Data 2	<delay_msb>

The delay individually defines the duration of the two periods of time to wait until the bit timing parameters switch is done (first period) and before transmitting any CAN message with the new bit timing parameters after performing the switch (second period). The time unit of switch delay is 1 ms.

- Save the configuration by sending the following message (on the NEW baudrate):

<i>Item</i>	<i>Value</i>
COB-ID	0x7E5
Length	1
Data 0	0x17 (cs=23 for store configuration)

- The module will send the following response (any other response is a failure):

<i>Item</i>	<i>Value</i>
COB-ID	0x7E4
Length	3
Data 0	0x17 (cs=23 for store configuration)
Data 1	0x00
Data 2	0x00

- Set the module state to LSS-operation by sending the following message: (Note, the module will reset itself back to the pre-operational state)

<i>Item</i>	<i>Value</i>
COB-ID	0x7E5
Length	2
Data 0	0x04 (cs=4 for switch state global)
Data 1	0x00 (switches to waiting state)

5.2 Communication Objects (DS-301)

The communication objects supported by the AX100261 Controller are listed in the following table. A more detailed description of some of the objects is given in the following subchapters. Only those objects that have device-profile specific information are described. For more information on the other objects, refer to the generic CANopen protocol specification DS-301.

<i>Index (hex)</i>	<i>Object</i>	<i>Object Type</i>	<i>Data Type</i>	<i>Access</i>	<i>PDO Mapping</i>
1000	Device Type	VAR	UNSIGNED32	RO	No
1001	Error Register	VAR	UNSIGNED8	RO	No
1002	Manufacturer Status Register	VAR	UNSIGNED32	RO	No
1003	Pre-Defined Error Field	ARRAY	UNSIGNED32	RO	No
1009	Manufacturer Hardware Version	ARRAY	UNSIGNED8	RO	No
100A	Manufacturer Software Version	ARRAY	UNSIGNED8	RO	No
100C	Guard Time	VAR	UNSIGNED16	RW	No
100D	Life Time Factor	VAR	UNSIGNED8	RW	No
1010	Store Parameters	ARRAY	UNSIGNED32	RW	No
1011	Restore Default Parameters	ARRAY	UNSIGNED32	RW	No
1016	Consumer Heartbeat Time	ARRAY	UNSIGNED32	RW	No
1017	Producer Heartbeat Time	VAR	UNSIGNED16	RW	No
1018	Identity Object	RECORD		RO	No
1020	Verify Configuration	ARRAY	UNSIGNED32	RO	No
1029	Error Behavior	ARRAY	UNSIGNED8	RW	No
1400	RPDO1 Communication Parameter	RECORD		RW	No
1401	RPDO2 Communication Parameter	RECORD		RW	No
1402	RPDO3 Communication Parameter	RECORD		RW	No
1403	RPDO4 Communication Parameter	RECORD		RW	No
1600	RPDO1 Mapping Parameter	RECORD		RO	No
1601	RPDO2 Mapping Parameter	RECORD		RO	No
1602	RPDO3 Mapping Parameter	RECORD		RO	No
1603	RPDO4 Mapping Parameter	RECORD		RO	No
1800	TPDO1 Communication Parameter	RECORD		RW	No
1801	TPDO2 Communication Parameter	RECORD		RW	No
1802	TPDO3 Communication Parameter	RECORD		RW	No
1803	TPDO4 Communication Parameter	RECORD		RW	No
1A00	TPDO1 Mapping Parameter	RECORD		RW	No
1A01	TPDO2 Mapping Parameter	RECORD		RW	No
1A02	TPDO3 Mapping Parameter	RECORD		RW	No
1A03	TPDO4 Mapping Parameter	RECORD		RW	No

5.2.1 1000h Device Type

Index	Subindex	Data Type	Access	PDO Mapping	Value Range	Default Value	Description
1000	0	UINT32	RO	No	0x192	0x192	DS-402

5.2.2 1001h Error Register

Index	Subindex	Data Type	Access	PDO Mapping	Value Range	Default Value	Description
1001	0	UINT8	RO	No	0, 1	0	Error register

5.2.3 1002h Manufacturer Status Object

Index	Subindex	Data Type	Access	PDO Mapping	Value Range	Default Value	Description
1002	0	UINT32	RO	No	UINT32	0	Manufacturer debug information

5.2.4 1003h Pre-Defined Error Field

Index	Subindex	Data Type	Access	PDO Mapping	Value Range	Default Value	Description	
1003	0	UINT8	RW	No	15	15	Number of subindexes / reset error codes	
	1	UINT32	RO			UINT32	0	EMCY error code #1
	2							EMCY error code #2
	3							EMCY error code #3
	4							EMCY error code #4
	5							EMCY error code #5
	6							EMCY error code #6

5.2.5 1009h Manufacturer Status Object

Index	Subindex	Data Type	Access	PDO Mapping	Value Range	Default Value	Description
1009	0	UINT8	RO	No	UINT8	1	Manufacturer hardware version
	1	UINT8	RO	No	UINT8	.	
	2	UINT8	RO	No	UINT8	0	

5.2.6 100Ah Manufacturer Status Object

Index	Subindex	Data Type	Access	PDO Mapping	Value Range	Default Value	Description
100A	0	UINT8	RO	No	UINT8	1	Manufacturer software version
	1	UINT8	RO	No	UINT8	.	
	2	UINT8	RO	No	UINT8	0	

5.2.7 100Ch Manufacturer Status Object

Index	Subindex	Data Type	Access	PDO Mapping	Value Range	Default Value	Description
100C	0	UINT16	RW	No	UINT16	0	Guard time

5.2.8 100Dh Life Time Factor

Index	Subindex	Data Type	Access	PDO Mapping	Value Range	Default Value	Description
100D	0	UINT8	RW	No	UINT8	0	Guard time

5.2.9 1010h Store Parameters

Index	Subindex	Data Type	Access	PDO Mapping	Value Range	Default Value	Description	
1010	0	UINT8	RO	No	4	4	Number of subindexes	
	1	UINT32	RW			save	1	Write 0x65766173 ('e', 'v', 'a', 's') for storing ALL parameters
	2							Write 0x65766173 ('e', 'v', 'a', 's') for storing Communication parameters
	3							Write 0x65766173 ('e', 'v', 'a', 's') for storing Application parameters
	4							Write 0x65766173 ('e', 'v', 'a', 's') for storing Manufacturer parameters

5.2.10 1011h Restore Parameters

Index	Subindex	Data Type	Access	PDO Mapping	Value Range	Default Value	Description	
1011	0	UINT8	RO	No	4	4	Number of subindexes	
	1	UINT32	RW			load	1	Write 0x4616F6C ('d', 'a', 'o', 'l') for restoring ALL parameters
	2							Write 0x4616F6C ('d', 'a', 'o', 'l') for restoring Communication parameters
	3							Write 0x4616F6C ('d', 'a', 'o', 'l') for restoring Application parameters
	4							Write 0x4616F6C ('d', 'a', 'o', 'l') for restoring Manufacturer parameters

5.2.11 1016h Consumer Heartbeat Time

Index	Subindex	Data Type	Access	PDO Mapping	Value Range	Default Value	Description	
1016	0	UINT8	RO	No	4	4	Number of subindexes	
	1	UINT32	RW			UINT32	0	Consumer heartbeat time
	2							bits 31-24: reserved
	3							bits 23-16: Node ID
	4							bits 15-0: heartbeat time in milliseconds

5.2.12 1017h Producer Heartbeat Time

Index	Subindex	Data Type	Access	PDO Mapping	Value Range	Default Value	Description
1017	0	UINT16	RW	No	10-65000	0	Producer heartbeat time in milliseconds

5.2.13 1018h Identity Object

Index	Subindex	Data Type	Access	PDO Mapping	Value Range	Default Value	Description	
1018	0	UINT8	RO	No	4	4	Number of subindexes	
	1	UINT32				UINT32	0x55	Vendor ID (Axiomatic Technologies)
	2						0xAA100261	Product Code
	3							Revision Number
	4							Serial Number

5.2.14 1020h Verify Configuration

Index	Subindex	Data Type	Access	PDO Mapping	Value Range	Default Value	Description	
1020	0	UINT8	RO	No	4	4	Number of subindexes	
	1	UINT32				UINT32		Configuration date: DD-MM-YYYY
	2							Configuration time: HH-MM

5.2.15 1029h Error Behavior

Index	Subindex	Data Type	Access	PDO Mapping	Value Range	Default Value	Description	
1029	0	UINT8	RO	No	6	4	Number of subindexes	
	1		RW			0-2	1 (no change)	State transition on Comm. fault
	2							State transition on DI fault
	3							State transition on AI fault
	4							State transition on DO fault
	5							State transition on AO fault
	6							State transition on other faults

5.2.16 1400h RPDO 1 Communication Parameters

Index	Subindex	Data Type	Access	PDO Mapping	Value Range	Default Value	Description
1400	0	UINT8	RO	No	4	4	Number of subindexes
	1	UINT32	RW		UINT32	0x4000027F	COB-ID
	2	UINT8			UINT8	0xFF	Transmission type
	3	UINT16			UINT16	0	Inhibit time
	4	UINT8			UINT8	0	Compatibility entry
	5	UINT16			UINT16	0	Event timer

5.2.17 1401h RPDO 2 Communication Parameters

Index	Subindex	Data Type	Access	PDO Mapping	Value Range	Default Value	Description
1401	0	UINT8	RO	No	4	4	Number of subindexes
	1	UINT32	RW		UINT32	0xC000037F	COB-ID
	2	UINT8			UINT8	0xFF	Transmission type
	3	UINT16			UINT16	0	Inhibit time
	4	UINT8			UINT8	0	Compatibility entry
	5	UINT16			UINT16	0	Event timer

5.2.18 1402h RPDO 3 Communication Parameters

Index	Subindex	Data Type	Access	PDO Mapping	Value Range	Default Value	Description
1402	0	UINT8	RO	No	4	4	Number of subindexes
	1	UINT32	RW		UINT32	0xC000047F	COB-ID
	2	UINT8			UINT8	0xFF	Transmission type
	3	UINT16			UINT16	0	Inhibit time
	4	UINT8			UINT8	0	Compatibility entry
	5	UINT16			UINT16	0	Event timer

5.2.19 1403h RPDO 4 Communication Parameters

Index	Subindex	Data Type	Access	PDO Mapping	Value Range	Default Value	Description
1403	0	UINT8	RO	No	4	4	Number of subindexes
	1	UINT32	RW		UINT32	0xC000057F	COB-ID
	2	UINT8			UINT8	0xFF	Transmission type
	3	UINT16			UINT16	0	Inhibit time
	4	UINT8			UINT8	0	Compatibility entry
	5	UINT16			UINT16	0	Event timer

5.2.20 1600h RPDO 1 Mapping Parameters

Index	Subindex	Data Type	Access	PDO Mapping	Value Range	Default Value	Description
1600	0	UINT8	RW	No	0-8	8	Number of subindexes
	1	UINT32			UINT32	0x40020508	LIN Signal 5
	2					0x40020608	LIN Signal 6
	3					0x40020708	LIN Signal 7
	4					0x40020808	LIN Signal 8
	5					0x40020908	LIN Signal 9
	6					0x40020108	LIN Signal 1
	7					0x40020208	LIN Signal 2
	8					0x40030208	CAN Receive 2

5.2.21 1601h RPDO 2 Mapping Parameters

Index	Subindex	Data Type	Access	PDO Mapping	Value Range	Default Value	Description
1601	0	UINT8	RW	No	0-8	0	Number of subindexes
	1	UINT32			UINT32	0	Not used by default
	2					0	Not used by default
	3					0	Not used by default
	4					0	Not used by default
	5					0	Not used by default
	6					0	Not used by default
	7					0	Not used by default
	8					0	Not used by default

5.2.22 1602h RPDO 3 Mapping Parameters

Index	Subindex	Data Type	Access	PDO Mapping	Value Range	Default Value	Description
1601	0	UINT8	RW	No	0-8	0	Number of subindexes
	1	UINT32			UINT32	0	Not used by default
	2					0	Not used by default
	3					0	Not used by default
	4					0	Not used by default
	5					0	Not used by default
	6					0	Not used by default
	7					0	Not used by default
	8					0	Not used by default

5.2.23 1603h RPDO 4 Mapping Parameters

Index	Subindex	Data Type	Access	PDO Mapping	Value Range	Default Value	Description
1601	0	UINT8	RW	No	0-8	0	Number of subindexes
	1	UINT32			UINT32	0	Not used by default
	2				0	Not used by default	
	3				0	Not used by default	
	4				0	Not used by default	
	5				0	Not used by default	
	6				0	Not used by default	
	7				0	Not used by default	
	8				0	Not used by default	

5.2.24 1800h TPDO 1 Communication Parameters

Index	Subindex	Data Type	Access	PDO Mapping	Value Range	Default Value	Description
1800	0	UINT8	RO	No	4	4	Number of subindexes
	1	UINT32	RW		UINT32	0x400001D0	COB-ID
	2	UINT8			UINT8	0xFE	Transmission type
	3	UINT16			UINT16	0	Inhibit time
	4	UINT8			UINT8	0	Compatibility entry
	5	UINT16			UINT16	0x3E8	Event timer

5.2.25 1801h TPDO 2 Communication Parameters

Index	Subindex	Data Type	Access	PDO Mapping	Value Range	Default Value	Description
1801	0	UINT8	RO	No	4	4	Number of subindexes
	1	UINT32	RW		UINT32	0xC00002D0	COB-ID
	2	UINT8			UINT8	0xFE	Transmission type
	3	UINT16			UINT16	0	Inhibit time
	4	UINT8			UINT8	0	Compatibility entry
	5	UINT16			UINT16	0	Event timer

5.2.26 1802h TPDO 3 Communication Parameters

Index	Subindex	Data Type	Access	PDO Mapping	Value Range	Default Value	Description
1802	0	UINT8	RO	No	4	4	Number of subindexes
	1	UINT32	RW		UINT32	0xC00003D0	COB-ID
	2	UINT8			UINT8	0xFE	Transmission type
	3	UINT16			UINT16	0	Inhibit time
	4	UINT8			UINT8	0	Compatibility entry

	5	UINT16			UINT16	0	Event timer
--	---	--------	--	--	--------	---	-------------

5.2.27 1803h TPDO 4 Communication Parameters

Index	Subindex	Data Type	Access	PDO Mapping	Value Range	Default Value	Description
1803	0	UINT8	RO	No	4	4	Number of subindexes
	1	UINT32	RW		UINT32	0xC00004D0	COB-ID
	2	UINT8			UINT8	0xFE	Transmission type
	3	UINT16			UINT16	0	Inhibit time
	4	UINT8			UINT8	0	Compatibility entry
	5	UINT16			UINT16	0	Event timer

5.2.28 1A00h TPDO 1 Mapping Parameters

Index	Subindex	Data Type	Access	PDO Mapping	Value Range	Default Value	Description
1A00	0	UINT8	RW	No	0-8	8	Number of subindexes
	1	UINT32			UINT32	0x40020508	LIN Signal 5
	2					0x40020608	LIN Signal 6
	3					0x40020708	LIN Signal 7
	4					0x40020808	LIN Signal 8
	5					0x40020908	LIN Signal 9
	6					0x40020108	LIN Signal 1
	7					0x40020208	LIN Signal 2
	8					0x40030208	CAN Receive 2

5.2.29 1A01h TPDO 2 Mapping Parameters

Index	Subindex	Data Type	Access	PDO Mapping	Value Range	Default Value	Description
1A01	0	UINT8	RW	No	0-8	0	Number of subindexes
	1	UINT32			UINT32	0	Not used by default
	2					0	Not used by default
	3					0	Not used by default
	4					0	Not used by default
	5					0	Not used by default
	6					0	Not used by default
	7					0	Not used by default
	8					0	Not used by default

5.2.30 1A02h TPDO 3 Mapping Parameters

Index	Subindex	Data Type	Access	PDO Mapping	Value Range	Default Value	Description
-------	----------	-----------	--------	-------------	-------------	---------------	-------------

1A02	0	UINT8	RW	No	0-8	0	Number of subindexes
	1	UINT32			0	0	Not used by default
	2						Not used by default
	3						Not used by default
	4						Not used by default
	5						Not used by default
	6						Not used by default
	7						Not used by default
	8						Not used by default

5.2.31 1A03h TPDO 4 Mapping Parameters

Index	Subindex	Data Type	Access	PDO Mapping	Value Range	Default Value	Description
1A03	0	UINT8	RW	No	0-8	0	Number of subindexes
	1	UINT32			0	0	Not used by default
	2						Not used by default
	3						Not used by default
	4						Not used by default
	5						Not used by default
	6						Not used by default
	7						Not used by default
	8						Not used by default

5.3 Manufacturer Objects

Index (hex)	Object	Object Type	Data Type	Access	PDO Mapping
2000	Slew Rate	VAR	UNSIGNED8	RW	No
2001	LIN Node Type	VAR	UNSIGNED16	RW	No
2002	LIN Baud Rate	VAR	UNSIGNED16	RW	No
2003	LIN Tick Time	VAR	UNSIGNED16	RW	No
2100	LIN Signal 1 Byte Array	ARRAY	UNSIGNED8	RW	No
2101	LIN Signal 2 Byte Array	ARRAY	UNSIGNED8	RW	No
2102	LIN Signal 3 Byte Array	ARRAY	UNSIGNED8	RW	No
2103	LIN Signal 4 Byte Array	ARRAY	UNSIGNED8	RW	No
2104	LIN Signal 5 Byte Array	ARRAY	UNSIGNED8	RW	No
2105	LIN Signal 6 Byte Array	ARRAY	UNSIGNED8	RW	No
2106	LIN Signal 7 Byte Array	ARRAY	UNSIGNED8	RW	No
2107	LIN Signal 8 Byte Array	ARRAY	UNSIGNED8	RW	No
2108	LIN Signal 9 Byte Array	ARRAY	UNSIGNED8	RW	No
2109	LIN Signal 10 Byte Array	ARRAY	UNSIGNED8	RW	No
210A	LIN Signal 11 Byte Array	ARRAY	UNSIGNED8	RW	No
210B	LIN Signal 12 Byte Array	ARRAY	UNSIGNED8	RW	No
210C	LIN Signal 13 Byte Array	ARRAY	UNSIGNED8	RW	No
210D	LIN Signal 14 Byte Array	ARRAY	UNSIGNED8	RW	No
210E	LIN Signal 15 Byte Array	ARRAY	UNSIGNED8	RW	No
210F	LIN Signal 16 Byte Array	ARRAY	UNSIGNED8	RW	No
2110	LIN Signal 17 Byte Array	ARRAY	UNSIGNED8	RW	No
2111	LIN Signal 18 Byte Array	ARRAY	UNSIGNED8	RW	No
2112	LIN Signal 19 Byte Array	ARRAY	UNSIGNED8	RW	No
2113	LIN Signal 20 Byte Array	ARRAY	UNSIGNED8	RW	No

2114	LIN Signal 21 Byte Array	ARRAY	UNSIGNED8	RW	No
2115	LIN Signal 22 Byte Array	ARRAY	UNSIGNED8	RW	No
2116	LIN Signal 23 Byte Array	ARRAY	UNSIGNED8	RW	No
2117	LIN Signal 24 Byte Array	ARRAY	UNSIGNED8	RW	No
2118	LIN Signal 25 Byte Array	ARRAY	UNSIGNED8	RW	No
2119	LIN Signal 26 Byte Array	ARRAY	UNSIGNED8	RW	No
211A	LIN Signal 27 Byte Array	ARRAY	UNSIGNED8	RW	No
211B	LIN Signal 28 Byte Array	ARRAY	UNSIGNED8	RW	No
211C	LIN Signal 29 Byte Array	ARRAY	UNSIGNED8	RW	No
211D	LIN Signal 30 Byte Array	ARRAY	UNSIGNED8	RW	No
211E	LIN Signal 31 Byte Array	ARRAY	UNSIGNED8	RW	No
211F	LIN Signal 32 Byte Array	ARRAY	UNSIGNED8	RW	No
2120	LIN Signal 33 Byte Array	ARRAY	UNSIGNED8	RW	No
2121	LIN Signal 34 Byte Array	ARRAY	UNSIGNED8	RW	No
2122	LIN Signal 35 Byte Array	ARRAY	UNSIGNED8	RW	No
2130	LIN Signal Type	ARRAY	UNSIGNED8	RW	No
2131	LIN Signal Source	ARRAY	UNSIGNED8	RW	No
2132	LIN Signal Autoreset Time	ARRAY	UNSIGNED16	RW	No
2133	LIN Signal Bit Size	ARRAY	UNSIGNED8	RW	No
2134	LIN Signal Encoding Type	ARRAY	UNSIGNED8	RW	No
2135	LIN Signal Minimum Value	ARRAY	UNSIGNED32	RW	No
2136	LIN Signal Maximum Value	ARRAY	UNSIGNED32	RW	No
2137	LIN Signal Scale	ARRAY	UNSIGNED32	RW	No
2138	LIN Signal Offset	ARRAY	UNSIGNED32	RW	No
2139	LIN Signal Initiate Scalar	ARRAY	UNSIGNED16	RW	No
2200	LIN Unconditional Frame Kind	ARRAY	UNSIGNED8	RW	No
2201	LIN Unconditional Frame ID	ARRAY	UNSIGNED8	RW	No
2202	LIN Unconditional Frame Triggered Frame	ARRAY	UNSIGNED8	RW	No
2203	LIN Unconditional Frame Size	ARRAY	UNSIGNED8	RW	No
2204	LIN Unconditional Frame Checksum Type	ARRAY	UNSIGNED8	RW	No
2210	LIN Unconditional Frame 1 Number	ARRAY	UNSIGNED8	RW	No
2211	LIN Unconditional Frame 1 Offset	ARRAY	UNSIGNED8	RW	No
2220	LIN Unconditional Frame 2 Number	ARRAY	UNSIGNED8	RW	No
2221	LIN Unconditional Frame 2 Offset	ARRAY	UNSIGNED8	RW	No
2230	LIN Unconditional Frame 3 Number	ARRAY	UNSIGNED8	RW	No
2231	LIN Unconditional Frame 3 Offset	ARRAY	UNSIGNED8	RW	No
2240	LIN Unconditional Frame 4 Number	ARRAY	UNSIGNED8	RW	No
2241	LIN Unconditional Frame 4 Offset	ARRAY	UNSIGNED8	RW	No
2250	LIN Unconditional Frame 5 Number	ARRAY	UNSIGNED8	RW	No
2251	LIN Unconditional Frame 5 Offset	ARRAY	UNSIGNED8	RW	No
2260	LIN Unconditional Frame 6 Number	ARRAY	UNSIGNED8	RW	No
2261	LIN Unconditional Frame 6 Offset	ARRAY	UNSIGNED8	RW	No
2270	LIN Unconditional Frame 7 Number	ARRAY	UNSIGNED8	RW	No
2271	LIN Unconditional Frame 7 Offset	ARRAY	UNSIGNED8	RW	No
2280	LIN Unconditional Frame 8 Number	ARRAY	UNSIGNED8	RW	No
2281	LIN Unconditional Frame 8 Offset	ARRAY	UNSIGNED8	RW	No
2290	LIN Unconditional Frame 9 Number	ARRAY	UNSIGNED8	RW	No
2291	LIN Unconditional Frame 9 Offset	ARRAY	UNSIGNED8	RW	No
22A0	LIN Unconditional Frame 10 Number	ARRAY	UNSIGNED8	RW	No
22A1	LIN Unconditional Frame 10 Offset	ARRAY	UNSIGNED8	RW	No
2300	LIN Event Triggered Frame Kind	ARRAY	UNSIGNED8	RW	No
2301	LIN Event Triggered Frame ID	ARRAY	UNSIGNED8	RW	No
2302	LIN Event Triggered Frame Size	ARRAY	UNSIGNED8	RW	No
2303	LIN Event Triggered Frame Checksum Type	ARRAY	UNSIGNED8	RW	No
2304	LIN Event Triggered Frame Collision Resolving Schedule Table Number	ARRAY	UNSIGNED8	RW	No

2310	LIN Event Triggered Frame Unconditional Frame Number	ARRAY	UNSIGNED8	RW	No
2400	LIN Sporadic Frame Kind	ARRAY	UNSIGNED8	RW	No
2410	LIN Sporadic Frame Unconditional Frame Number	ARRAY	UNSIGNED8	RW	No
2500	LIN Main Schedule Type	ARRAY	UNSIGNED8	RW	No
2501	LIN Main Schedule Number	ARRAY	UNSIGNED8	RW	No
2502	LIN Main Schedule Delay	ARRAY	UNSIGNED32	RW	No
2600	LIN Collision Schedule Type	ARRAY	UNSIGNED8	RW	No
2601	LIN Collision Schedule Number	ARRAY	UNSIGNED8	RW	No
2602	LIN Collision Schedule Delay	ARRAY	UNSIGNED16	RW	No
2700	Global Parameter Continuous	ARRAY	UNSIGNED32	RW	No
2701	Global Parameter Discrete Signal	ARRAY	UNSIGNED32	RW	No
3010	Binary Function Signal 1 Source	ARRAY	UNSIGNED8	RW	No
3011	Binary Function Signal 1 Is Signal Default	ARRAY	UNSIGNED8	RW	No
3012	Binary Function Signal 1 Default Value	ARRAY	REAL32	RW	No
3013	Binary Function Signal 1 Unary Function	ARRAY	UNSIGNED8	RW	No
3014	Binary Function Signal 1 Scale	ARRAY	REAL32	RW	No
3015	Binary Function Signal 1 Offset	ARRAY	REAL32	RW	No
3020	Binary Function Signal 2 Source	ARRAY	UNSIGNED8	RW	No
3021	Binary Function Signal 2 Is Signal Default	ARRAY	UNSIGNED8	RW	No
3022	Binary Function Signal 2 Default Value	ARRAY	REAL32	RW	No
3023	Binary Function Signal 2 Unary Function	ARRAY	UNSIGNED8	RW	No
3024	Binary Function Signal 2 Scale	ARRAY	REAL32	RW	No
3025	Binary Function Signal 2 Offset	ARRAY	REAL32	RW	No
3030	Binary Function Signal 3 Source	ARRAY	UNSIGNED8	RW	No
3031	Binary Function Signal 3 Is Signal Default	ARRAY	UNSIGNED8	RW	No
3032	Binary Function Signal 3 Default Value	ARRAY	REAL32	RW	No
3033	Binary Function Signal 3 Unary Function	ARRAY	UNSIGNED8	RW	No
3034	Binary Function Signal 3 Scale	ARRAY	REAL32	RW	No
3035	Binary Function Signal 3 Offset	ARRAY	REAL32	RW	No
3040	Binary Function Signal 4 Source	ARRAY	UNSIGNED8	RW	No
3041	Binary Function Signal 4 Is Signal Default	ARRAY	UNSIGNED8	RW	No
3042	Binary Function Signal 4 Default Value	ARRAY	REAL32	RW	No
3043	Binary Function Signal 4 Unary Function	ARRAY	UNSIGNED8	RW	No
3044	Binary Function Signal 4 Scale	ARRAY	REAL32	RW	No
3045	Binary Function Signal 4 Offset	ARRAY	REAL32	RW	No
3050	Binary Function Signal 5 Source	ARRAY	UNSIGNED8	RW	No
3051	Binary Function Signal 5 Is Signal Default	ARRAY	UNSIGNED8	RW	No
3052	Binary Function Signal 5 Default Value	ARRAY	REAL32	RW	No
3053	Binary Function Signal 5 Unary Function	ARRAY	UNSIGNED8	RW	No
3054	Binary Function Signal 5 Scale	ARRAY	REAL32	RW	No
3055	Binary Function Signal 5 Offset	ARRAY	REAL32	RW	No
3060	Binary Function Signal 6 Source	ARRAY	UNSIGNED8	RW	No
3061	Binary Function Signal 6 Is Signal Default	ARRAY	UNSIGNED8	RW	No
3062	Binary Function Signal 6 Default Value	ARRAY	REAL32	RW	No
3063	Binary Function Signal 6 Unary Function	ARRAY	UNSIGNED8	RW	No
3064	Binary Function Signal 6 Scale	ARRAY	REAL32	RW	No
3065	Binary Function Signal 6 Offset	ARRAY	REAL32	RW	No
3070	Binary Function Signal 7 Source	ARRAY	UNSIGNED8	RW	No
3071	Binary Function Signal 7 Is Signal Default	ARRAY	UNSIGNED8	RW	No
3072	Binary Function Signal 7 Default Value	ARRAY	REAL32	RW	No
3073	Binary Function Signal 7 Unary Function	ARRAY	UNSIGNED8	RW	No
3074	Binary Function Signal 7 Scale	ARRAY	REAL32	RW	No
3075	Binary Function Signal 7 Offset	ARRAY	REAL32	RW	No
3080	Binary Function Signal 8 Source	ARRAY	UNSIGNED8	RW	No

3081	Binary Function Signal 8 Is Signal Default	ARRAY	UNSIGNED8	RW	No
3082	Binary Function Signal 8 Default Value	ARRAY	REAL32	RW	No
3083	Binary Function Signal 8 Unary Function	ARRAY	UNSIGNED8	RW	No
3084	Binary Function Signal 8 Scale	ARRAY	REAL32	RW	No
3085	Binary Function Signal 8 Offset	ARRAY	REAL32	RW	No
3090	Binary Function Signal 9 Source	ARRAY	UNSIGNED8	RW	No
3091	Binary Function Signal 9 Is Signal Default	ARRAY	UNSIGNED8	RW	No
3092	Binary Function Signal 9 Default Value	ARRAY	REAL32	RW	No
3093	Binary Function Signal 9 Unary Function	ARRAY	UNSIGNED8	RW	No
3094	Binary Function Signal 9 Scale	ARRAY	REAL32	RW	No
3095	Binary Function Signal 9 Offset	ARRAY	REAL32	RW	No
30A0	Binary Function Signal 10 Source	ARRAY	UNSIGNED8	RW	No
30A1	Binary Function Signal 10 Is Signal Default	ARRAY	UNSIGNED8	RW	No
30A2	Binary Function Signal 10 Default Value	ARRAY	REAL32	RW	No
30A3	Binary Function Signal 10 Unary Function	ARRAY	UNSIGNED8	RW	No
30A4	Binary Function Signal 10 Scale	ARRAY	REAL32	RW	No
30A5	Binary Function Signal 10 Offset	ARRAY	REAL32	RW	No
30B0	Binary Function Signal 11 Source	ARRAY	UNSIGNED8	RW	No
30B1	Binary Function Signal 11 Is Signal Default	ARRAY	UNSIGNED8	RW	No
30B2	Binary Function Signal 11 Default Value	ARRAY	REAL32	RW	No
30B3	Binary Function Signal 11 Unary Function	ARRAY	UNSIGNED8	RW	No
30B4	Binary Function Signal 11 Scale	ARRAY	REAL32	RW	No
30B5	Binary Function Signal 11 Offset	ARRAY	REAL32	RW	No
30C0	Binary Function Signal 12 Source	ARRAY	UNSIGNED8	RW	No
30C1	Binary Function Signal 12 Is Signal Default	ARRAY	UNSIGNED8	RW	No
30C2	Binary Function Signal 12 Default Value	ARRAY	REAL32	RW	No
30C3	Binary Function Signal 12 Unary Function	ARRAY	UNSIGNED8	RW	No
30C4	Binary Function Signal 12 Scale	ARRAY	REAL32	RW	No
30C5	Binary Function Signal 12 Offset	ARRAY	REAL32	RW	No
30D0	Binary Function Signal 13 Source	ARRAY	UNSIGNED8	RW	No
30D1	Binary Function Signal 13 Is Signal Default	ARRAY	UNSIGNED8	RW	No
30D2	Binary Function Signal 13 Default Value	ARRAY	REAL32	RW	No
30D3	Binary Function Signal 13 Unary Function	ARRAY	UNSIGNED8	RW	No
30D4	Binary Function Signal 13 Scale	ARRAY	REAL32	RW	No
30D5	Binary Function Signal 13 Offset	ARRAY	REAL32	RW	No
30E0	Binary Function Signal 14 Source	ARRAY	UNSIGNED8	RW	No
30E1	Binary Function Signal 14 Is Signal Default	ARRAY	UNSIGNED8	RW	No
30E2	Binary Function Signal 14 Default Value	ARRAY	REAL32	RW	No
30E3	Binary Function Signal 14 Unary Function	ARRAY	UNSIGNED8	RW	No
30E4	Binary Function Signal 14 Scale	ARRAY	REAL32	RW	No
30E5	Binary Function Signal 14 Offset	ARRAY	REAL32	RW	No
30F0	Binary Function Signal 15 Source	ARRAY	UNSIGNED8	RW	No
30F1	Binary Function Signal 15 Is Signal Default	ARRAY	UNSIGNED8	RW	No
30F2	Binary Function Signal 15 Default Value	ARRAY	REAL32	RW	No
30F3	Binary Function Signal 15 Unary Function	ARRAY	UNSIGNED8	RW	No
30F4	Binary Function Signal 15 Scale	ARRAY	REAL32	RW	No
30F5	Binary Function Signal 15 Offset	ARRAY	REAL32	RW	No
300A	Binary Function Output Function	ARRAY	UNSIGNED8	RW	No
300B	Binary Function Output Scale	ARRAY	REAL32	RW	No
300C	Binary Function Output Offset	ARRAY	REAL32	RW	No
4000	Global VPS Data	VAR	REAL32	RO	Yes
4001	Global Temperature Data	VAR	REAL32	RO	Yes
4002	LIN Data	ARRAY	INTEGER16	RW	Yes
4003	Extra CANopen Data Signal	ARRAY	UNSIGNED32	RW	Yes
4004	LIN Driver Data Status	VAR	UNSIGNED8	RO	No
4005	LIN Driver Slave Error	VAR	UNSIGNED8	RO	No

5555	Start in Operational Mode	VAR	UNSIGEND8	RW	No
55AA	Start Bootloader	VAR	UNSIGEND8	RW	No
5B50	Change Baud Rate	VAR	UNSIGNED8	RW	No
5B51	Change Node ID	VAR	UNSIGNED8	RW	No

5.3.1 2000h Slew Rate

Index	Subindex	Data Type	Access	PDO Mapping	Value Range	Default Value	Description
2000	0	UINT8	RW	No	0-1	0	0 = Low slew rate: 1 = High slew rate

5.3.2 2001h LIN Node Type

Index	Subindex	Data Type	Access	PDO Mapping	Value Range	Default Value	Description
2001	0	UINT8	RW	No	0-2	1	By default: Master. See Table 2

5.3.3 2002h LIN Baud Rate

Index	Subindex	Data Type	Access	PDO Mapping	Value Range	Default Value	Description
2002	0	UINT16	RW	No	2400-20000	10417	See Table 2

5.3.4 2003h LIN Tick Time

Index	Subindex	Data Type	Access	PDO Mapping	Value Range	Default Value	Description
2003	0	UINT8	RW	No	1-10000	10	See Table 2

5.3.5 2100h LIN Signal 1 – 2122h LIN Signal 35 Byte Array

Index	Subindex	Data Type	Access	PDO Mapping	Value Range	Default Value	Description
2100 - 2122	0	UINT8	RO	No	8	8	Number of subindexes
	1	UINT8	RW	No	0-127	0	See Table 3
	2	UINT8	RW	No	0-127	0	See Table 3
	3	UINT8	RW	No	0-127	0	See Table 3
	4	UINT8	RW	No	0-127	0	See Table 3
	5	UINT8	RW	No	0-127	0	See Table 3
	6	UINT8	RW	No	0-127	0	See Table 3
	7	UINT8	RW	No	0-127	0	See Table 3
	8	UINT8	RW	No	0-127	0	See Table 3

5.3.6 2130h LIN Signal 1 - 35 Type

Index	Subindex	Data Type	Access	PDO Mapping	Value Range	Default Value	Description
-------	----------	-----------	--------	-------------	-------------	---------------	-------------

2130	0	UINT8	RO	No	8	8	Number of subindexes
	1	UINT8	RW	No	0-2	1	See Table 3
	2	UINT8	RW	No	0-2	1	See Table 3
	3	UINT8	RW	No	0-2	1	See Table 3
	4	UINT8	RW	No	0-2	0	See Table 3
	5	UINT8	RW	No	0-2	1	See Table 3
	6	UINT8	RW	No	0-2	1	See Table 3
	7	UINT8	RW	No	0-2	1	See Table 3
	8	UINT8	RW	No	0-2	1	See Table 3
	9	UINT8	RW	No	0-2	1	See Table 3
	10	UINT8	RW	No	0-2	0	See Table 3
	11	UINT8	RW	No	0-2	0	See Table 3
	12	UINT8	RW	No	0-2	0	See Table 3
	13	UINT8	RW	No	0-2	0	See Table 3
	14	UINT8	RW	No	0-2	0	See Table 3
	15	UINT8	RW	No	0-2	0	See Table 3
	16	UINT8	RW	No	0-2	0	See Table 3
	17	UINT8	RW	No	0-2	0	See Table 3
	18	UINT8	RW	No	0-2	0	See Table 3
	19	UINT8	RW	No	0-2	0	See Table 3
	20	UINT8	RW	No	0-2	1	See Table 3
	21	UINT8	RW	No	0-2	1	See Table 3
	22	UINT8	RW	No	0-2	0	See Table 3
	23	UINT8	RW	No	0-2	0	See Table 3
	24	UINT8	RW	No	0-2	0	See Table 3
	25	UINT8	RW	No	0-2	0	See Table 3
	26	UINT8	RW	No	0-2	0	See Table 3
	27	UINT8	RW	No	0-2	0	See Table 3
	28	UINT8	RW	No	0-2	0	See Table 3
	29	UINT8	RW	No	0-2	0	See Table 3
	30	UINT8	RW	No	0-2	0	See Table 3
	31	UINT8	RW	No	0-2	0	See Table 3
	32	UINT8	RW	No	0-2	0	See Table 3
	33	UINT8	RW	No	0-2	0	See Table 3
	34	UINT8	RW	No	0-2	0	See Table 3
35	UINT8	RW	No	0-2	0	See Table 3	

5.3.7 2131h LIN Signal Source 1 – 35

Index	Subindex	Data Type	Access	PDO Mapping	Value Range	Default Value	Description
2131	0	UINT8	RO	No	8	8	Number of subindexes
	1	UINT8	RW	No	0-60	0	See Table 3
	2	UINT8	RW	No	0-60	0	See Table 3
	3	UINT8	RW	No	0-60	0	See Table 3
	4	UINT8	RW	No	0-60	0	See Table 3
	5	UINT8	RW	No	0-60	5	See Table 3
	6	UINT8	RW	No	0-60	6	See Table 3
	7	UINT8	RW	No	0-60	7	See Table 3
	8	UINT8	RW	No	0-60	8	See Table 3

9	UINT8	RW	No	0-60	9	See Table 3
10	UINT8	RW	No	0-60	0	See Table 3
11	UINT8	RW	No	0-60	0	See Table 3
12	UINT8	RW	No	0-60	0	See Table 3
13	UINT8	RW	No	0-60	0	See Table 3
14	UINT8	RW	No	0-60	0	See Table 3
15	UINT8	RW	No	0-60	0	See Table 3
16	UINT8	RW	No	0-60	0	See Table 3
17	UINT8	RW	No	0-60	0	See Table 3
18	UINT8	RW	No	0-60	0	See Table 3
19	UINT8	RW	No	0-60	0	See Table 3
20	UINT8	RW	No	0-60	0	See Table 3
21	UINT8	RW	No	0-60	0	See Table 3
22	UINT8	RW	No	0-60	0	See Table 3
23	UINT8	RW	No	0-60	0	See Table 3
24	UINT8	RW	No	0-60	0	See Table 3
25	UINT8	RW	No	0-60	0	See Table 3
26	UINT8	RW	No	0-60	0	See Table 3
27	UINT8	RW	No	0-60	0	See Table 3
28	UINT8	RW	No	0-60	0	See Table 3
29	UINT8	RW	No	0-60	0	See Table 3
30	UINT8	RW	No	0-60	0	See Table 3
31	UINT8	RW	No	0-60	0	See Table 3
32	UINT8	RW	No	0-60	0	See Table 3
33	UINT8	RW	No	0-60	0	See Table 3
34	UINT8	RW	No	0-60	0	See Table 3
35	UINT8	RW	No	0-60	0	See Table 3

5.3.8 2132h LIN Signal 1 - 35 Autoreset Time

Index	Subindex	Data Type	Access	PDO Mapping	Value Range	Default Value	Description
2132	0	UINT8	RO	No	8	8	Number of subindexes
	1	UINT16	RW	No	0-10000	0	See Table 3
	2	UINT16	RW	No	0-10000	0	See Table 3
	3	UINT16	RW	No	0-10000	0	See Table 3
	4	UINT16	RW	No	0-10000	0	See Table 3
	5	UINT16	RW	No	0-10000	5	See Table 3
	6	UINT16	RW	No	0-10000	6	See Table 3
	7	UINT16	RW	No	0-10000	7	See Table 3
	8	UINT16	RW	No	0-10000	8	See Table 3
	9	UINT16	RW	No	0-10000	9	See Table 3
	10	UINT16	RW	No	0-10000	0	See Table 3
	11	UINT16	RW	No	0-10000	0	See Table 3
	12	UINT16	RW	No	0-10000	0	See Table 3
	13	UINT16	RW	No	0-10000	0	See Table 3
	14	UINT16	RW	No	0-10000	0	See Table 3
	15	UINT16	RW	No	0-10000	0	See Table 3
	16	UINT16	RW	No	0-10000	0	See Table 3
	17	UINT16	RW	No	0-10000	0	See Table 3
	18	UINT16	RW	No	0-10000	0	See Table 3

19	UINT16	RW	No	0-10000	0	See Table 3
20	UINT16	RW	No	0-10000	0	See Table 3
21	UINT16	RW	No	0-10000	0	See Table 3
22	UINT16	RW	No	0-10000	0	See Table 3
23	UINT16	RW	No	0-10000	0	See Table 3
24	UINT16	RW	No	0-10000	0	See Table 3
25	UINT16	RW	No	0-10000	0	See Table 3
26	UINT16	RW	No	0-10000	0	See Table 3
27	UINT16	RW	No	0-10000	0	See Table 3
28	UINT16	RW	No	0-10000	0	See Table 3
29	UINT16	RW	No	0-10000	0	See Table 3
30	UINT16	RW	No	0-10000	0	See Table 3
31	UINT16	RW	No	0-10000	0	See Table 3
32	UINT16	RW	No	0-10000	0	See Table 3
33	UINT16	RW	No	0-10000	0	See Table 3
34	UINT16	RW	No	0-10000	0	See Table 3
35	UINT16	RW	No	0-10000	0	See Table 3

5.3.9 2133h LIN Signal 1 – 35 Bit size

Index	Subindex	Data Type	Access	PDO Mapping	Value Range	Default Value	Description
2133	0	UINT8	RO	No	8	8	Number of subindexes
	1	UINT8	RW	No	1-64	8	See Table 3
	2	UINT8	RW	No	1-64	8	See Table 3
	3	UINT8	RW	No	1-64	8	See Table 3
	4	UINT8	RW	No	1-64	1	See Table 3
	5	UINT8	RW	No	1-64	8	See Table 3
	6	UINT8	RW	No	1-64	8	See Table 3
	7	UINT8	RW	No	1-64	8	See Table 3
	8	UINT8	RW	No	1-64	8	See Table 3
	9	UINT8	RW	No	1-64	8	See Table 3
	10	UINT8	RW	No	1-64	1	See Table 3
	11	UINT8	RW	No	1-64	1	See Table 3
	12	UINT8	RW	No	1-64	1	See Table 3
	13	UINT8	RW	No	1-64	1	See Table 3
	14	UINT8	RW	No	1-64	1	See Table 3
	15	UINT8	RW	No	1-64	1	See Table 3
	16	UINT8	RW	No	1-64	1	See Table 3
	17	UINT8	RW	No	1-64	1	See Table 3
	18	UINT8	RW	No	1-64	1	See Table 3
	19	UINT8	RW	No	1-64	1	See Table 3
	20	UINT8	RW	No	1-64	8	See Table 3
	21	UINT8	RW	No	1-64	8	See Table 3
	22	UINT8	RW	No	1-64	1	See Table 3
	23	UINT8	RW	No	1-64	1	See Table 3
	24	UINT8	RW	No	1-64	1	See Table 3
	25	UINT8	RW	No	1-64	1	See Table 3
	26	UINT8	RW	No	1-64	1	See Table 3
	27	UINT8	RW	No	1-64	1	See Table 3
28	UINT8	RW	No	1-64	1	See Table 3	

	29	UINT8	RW	No	1-64	1	See Table 3
	30	UINT8	RW	No	1-64	1	See Table 3
	31	UINT8	RW	No	1-64	1	See Table 3
	32	UINT8	RW	No	1-64	1	See Table 3
	33	UINT8	RW	No	1-64	1	See Table 3
	34	UINT8	RW	No	1-64	1	See Table 3
	35	UINT8	RW	No	1-64	1	See Table 3

5.3.10 2134h LIN Signal 1 – 35 Encoding Type

Index	Subindex	Data Type	Access	PDO Mapping	Value Range	Default Value	Description
2134	0	UINT8	RO	No	8	8	Number of subindexes
	1	UINT8	RW	No	0-4	2	See Table 3
	2	UINT8	RW	No	0-4	2	See Table 3
	3	UINT8	RW	No	0-4	2	See Table 3
	4	UINT8	RW	No	0-4	0	See Table 3
	5	UINT8	RW	No	0-4	2	See Table 3
	6	UINT8	RW	No	0-4	2	See Table 3
	7	UINT8	RW	No	0-4	2	See Table 3
	8	UINT8	RW	No	0-4	2	See Table 3
	9	UINT8	RW	No	0-4	2	See Table 3
	10	UINT8	RW	No	0-4	0	See Table 3
	11	UINT8	RW	No	0-4	0	See Table 3
	12	UINT8	RW	No	0-4	0	See Table 3
	13	UINT8	RW	No	0-4	0	See Table 3
	14	UINT8	RW	No	0-4	0	See Table 3
	15	UINT8	RW	No	0-4	0	See Table 3
	16	UINT8	RW	No	0-4	0	See Table 3
	17	UINT8	RW	No	0-4	0	See Table 3
	18	UINT8	RW	No	0-4	0	See Table 3
	19	UINT8	RW	No	0-4	0	See Table 3
	20	UINT8	RW	No	0-4	2	See Table 3
	21	UINT8	RW	No	0-4	2	See Table 3
	22	UINT8	RW	No	0-4	0	See Table 3
	23	UINT8	RW	No	0-4	0	See Table 3
	24	UINT8	RW	No	0-4	0	See Table 3
	25	UINT8	RW	No	0-4	0	See Table 3
	26	UINT8	RW	No	0-4	0	See Table 3
	27	UINT8	RW	No	0-4	0	See Table 3
	28	UINT8	RW	No	0-4	0	See Table 3
	29	UINT8	RW	No	0-4	0	See Table 3
	30	UINT8	RW	No	0-4	0	See Table 3
	31	UINT8	RW	No	0-4	0	See Table 3
	32	UINT8	RW	No	0-4	0	See Table 3
	33	UINT8	RW	No	0-4	0	See Table 3
	34	UINT8	RW	No	0-4	0	See Table 3
35	UINT8	RW	No	0-4	0	See Table 3	

5.3.11 2135h LIN Signal 1 – 35 Minimum Value

Index	Subindex	Data Type	Access	PDO Mapping	Value Range	Default Value	Description
2135	0	UINT8	RO	No	8	8	Number of subindexes
	1	UINT32	RW	No	0x0-0xFFFFFFFF	0x0	See Table 3
	2	UINT32	RW	No	0x0-0xFFFFFFFF	0x0	See Table 3
	3	UINT32	RW	No	0x0-0xFFFFFFFF	0x0	See Table 3
	4	UINT32	RW	No	0x0-0xFFFFFFFF	0x0	See Table 3
	5	UINT32	RW	No	0x0-0xFFFFFFFF	0x0	See Table 3
	6	UINT32	RW	No	0x0-0xFFFFFFFF	0x0	See Table 3
	7	UINT32	RW	No	0x0-0xFFFFFFFF	0x0	See Table 3
	8	UINT32	RW	No	0x0-0xFFFFFFFF	0x0	See Table 3
	9	UINT32	RW	No	0x0-0xFFFFFFFF	0x0	See Table 3
	10	UINT32	RW	No	0x0-0xFFFFFFFF	0x0	See Table 3
	11	UINT32	RW	No	0x0-0xFFFFFFFF	0x0	See Table 3
	12	UINT32	RW	No	0x0-0xFFFFFFFF	0x0	See Table 3
	13	UINT32	RW	No	0x0-0xFFFFFFFF	0x0	See Table 3
	14	UINT32	RW	No	0x0-0xFFFFFFFF	0x0	See Table 3
	15	UINT32	RW	No	0x0-0xFFFFFFFF	0x0	See Table 3
	16	UINT32	RW	No	0x0-0xFFFFFFFF	0x0	See Table 3
	17	UINT32	RW	No	0x0-0xFFFFFFFF	0x0	See Table 3
	18	UINT32	RW	No	0x0-0xFFFFFFFF	0x0	See Table 3
	19	UINT32	RW	No	0x0-0xFFFFFFFF	0x0	See Table 3
	20	UINT32	RW	No	0x0-0xFFFFFFFF	0x0	See Table 3
	21	UINT32	RW	No	0x0-0xFFFFFFFF	0x0	See Table 3
	22	UINT32	RW	No	0x0-0xFFFFFFFF	0x0	See Table 3
	23	UINT32	RW	No	0x0-0xFFFFFFFF	0x0	See Table 3

24	UINT32	RW	No	0x0-0xFFFFFFFF	0x0	See Table 3
25	UINT32	RW	No	0x0-0xFFFFFFFF	0x0	See Table 3
26	UINT32	RW	No	0x0-0xFFFFFFFF	0x0	See Table 3
27	UINT32	RW	No	0x0-0xFFFFFFFF	0x0	See Table 3
28	UINT32	RW	No	0x0-0xFFFFFFFF	0x0	See Table 3
29	UINT32	RW	No	0x0-0xFFFFFFFF	0x0	See Table 3
30	UINT32	RW	No	0x0-0xFFFFFFFF	0x0	See Table 3
31	UINT32	RW	No	0x0-0xFFFFFFFF	0x0	See Table 3
32	UINT32	RW	No	0x0-0xFFFFFFFF	0x0	See Table 3
33	UINT32	RW	No	0x0-0xFFFFFFFF	0x0	See Table 3
34	UINT32	RW	No	0x0-0xFFFFFFFF	0x0	See Table 3
35	UINT32	RW	No	0x0-0xFFFFFFFF	0x0	See Table 3

5.3.12 2136h LIN Signal 1 – 35 Maximum Value

Index	Subindex	Data Type	Access	PDO Mapping	Value Range	Default Value	Description
2136	0	UINT8	RO	No	8	8	Number of subindexes
	1	UINT32	RW	No	0x0-0xFFFFFFFF	0xFE	See Table 3
	2	UINT32	RW	No	0x0-0xFFFFFFFF	0xFE	See Table 3
	3	UINT32	RW	No	0x0-0xFFFFFFFF	0xFE	See Table 3
	4	UINT32	RW	No	0x0-0xFFFFFFFF	0x1	See Table 3
	5	UINT32	RW	No	0x0-0xFFFFFFFF	0xFE	See Table 3
	6	UINT32	RW	No	0x0-0xFFFFFFFF	0xFE	See Table 3
	7	UINT32	RW	No	0x0-0xFFFFFFFF	0xFE	See Table 3
	8	UINT32	RW	No	0x0-0xFFFFFFFF	0xFE	See Table 3
	9	UINT32	RW	No	0x0-0xFFFFFFFF	0xFE	See Table 3
	10	UINT32	RW	No	0x0-0xFFFFFFFF	0x1	See Table 3
	11	UINT32	RW	No	0x0-0xFFFFFFFF	0x1	See Table 3

12	UINT32	RW	No	0x0-0xFFFFFFFF	0x1	See Table 3
13	UINT32	RW	No	0x0-0xFFFFFFFF	0x1	See Table 3
14	UINT32	RW	No	0x0-0xFFFFFFFF	0x1	See Table 3
15	UINT32	RW	No	0x0-0xFFFFFFFF	0x1	See Table 3
16	UINT32	RW	No	0x0-0xFFFFFFFF	0x1	See Table 3
17	UINT32	RW	No	0x0-0xFFFFFFFF	0x1	See Table 3
18	UINT32	RW	No	0x0-0xFFFFFFFF	0x1	See Table 3
19	UINT32	RW	No	0x0-0xFFFFFFFF	0x1	See Table 3
20	UINT32	RW	No	0x0-0xFFFFFFFF	0xFE	See Table 3
21	UINT32	RW	No	0x0-0xFFFFFFFF	0xFE	See Table 3
22	UINT32	RW	No	0x0-0xFFFFFFFF	0x1	See Table 3
23	UINT32	RW	No	0x0-0xFFFFFFFF	0x1	See Table 3
24	UINT32	RW	No	0x0-0xFFFFFFFF	0x1	See Table 3
25	UINT32	RW	No	0x0-0xFFFFFFFF	0x1	See Table 3
26	UINT32	RW	No	0x0-0xFFFFFFFF	0x1	See Table 3
27	UINT32	RW	No	0x0-0xFFFFFFFF	0x1	See Table 3
28	UINT32	RW	No	0x0-0xFFFFFFFF	0x1	See Table 3
29	UINT32	RW	No	0x0-0xFFFFFFFF	0x1	See Table 3
30	UINT32	RW	No	0x0-0xFFFFFFFF	0x1	See Table 3
31	UINT32	RW	No	0x0-0xFFFFFFFF	0x1	See Table 3
32	UINT32	RW	No	0x0-0xFFFFFFFF	0x1	See Table 3
33	UINT32	RW	No	0x0-0xFFFFFFFF	0x1	See Table 3
34	UINT32	RW	No	0x0-0xFFFFFFFF	0x1	See Table 3
35	UINT32	RW	No	0x0-0xFFFFFFFF	0x1	See Table 3

5.3.13 2137h LIN Signal 1 – 35 Scale

Index	Subindex	Data Type	Access	PDO Mapping	Value Range	Default Value	Description
-------	----------	-----------	--------	-------------	-------------	---------------	-------------

2137	0	UINT8	RO	No	8	8	Number of subindexes
	1	UINT32	RW	No	0x0- 0xFFFFFFFF	0x1	See Table 3
	2	UINT32	RW	No	0x0- 0xFFFFFFFF	0x1	See Table 3
	3	UINT32	RW	No	0x0- 0xFFFFFFFF	0x1	See Table 3
	4	UINT32	RW	No	0x0- 0xFFFFFFFF	0x1	See Table 3
	5	UINT32	RW	No	0x0- 0xFFFFFFFF	0x1	See Table 3
	6	UINT32	RW	No	0x0- 0xFFFFFFFF	0x1	See Table 3
	7	UINT32	RW	No	0x0- 0xFFFFFFFF	0x1	See Table 3
	8	UINT32	RW	No	0x0- 0xFFFFFFFF	0x1	See Table 3
	9	UINT32	RW	No	0x0- 0xFFFFFFFF	0x1	See Table 3
	10	UINT32	RW	No	0x0- 0xFFFFFFFF	0x1	See Table 3
	11	UINT32	RW	No	0x0- 0xFFFFFFFF	0x1	See Table 3
	12	UINT32	RW	No	0x0- 0xFFFFFFFF	0x1	See Table 3
	13	UINT32	RW	No	0x0- 0xFFFFFFFF	0x1	See Table 3
	14	UINT32	RW	No	0x0- 0xFFFFFFFF	0x1	See Table 3
	15	UINT32	RW	No	0x0- 0xFFFFFFFF	0x1	See Table 3
	16	UINT32	RW	No	0x0- 0xFFFFFFFF	0x1	See Table 3
	17	UINT32	RW	No	0x0- 0xFFFFFFFF	0x1	See Table 3
	18	UINT32	RW	No	0x0- 0xFFFFFFFF	0x1	See Table 3
	19	UINT32	RW	No	0x0- 0xFFFFFFFF	0x1	See Table 3
	20	UINT32	RW	No	0x0- 0xFFFFFFFF	0x1	See Table 3
	21	UINT32	RW	No	0x0- 0xFFFFFFFF	0x1	See Table 3
	22	UINT32	RW	No	0x0- 0xFFFFFFFF	0x1	See Table 3
	23	UINT32	RW	No	0x0- 0xFFFFFFFF	0x1	See Table 3
	24	UINT32	RW	No	0x0- 0xFFFFFFFF	0x1	See Table 3
	25	UINT32	RW	No	0x0- 0xFFFFFFFF	0x1	See Table 3

26	UINT32	RW	No	0x0-0xFFFFFFFF	0x1	See Table 3
27	UINT32	RW	No	0x0-0xFFFFFFFF	0x1	See Table 3
28	UINT32	RW	No	0x0-0xFFFFFFFF	0x1	See Table 3
29	UINT32	RW	No	0x0-0xFFFFFFFF	0x1	See Table 3
30	UINT32	RW	No	0x0-0xFFFFFFFF	0x1	See Table 3
31	UINT32	RW	No	0x0-0xFFFFFFFF	0x1	See Table 3
32	UINT32	RW	No	0x0-0xFFFFFFFF	0x1	See Table 3
33	UINT32	RW	No	0x0-0xFFFFFFFF	0x1	See Table 3
34	UINT32	RW	No	0x0-0xFFFFFFFF	0x1	See Table 3
35	UINT32	RW	No	0x0-0xFFFFFFFF	0x1	See Table 3

5.3.14 2138h LIN Signal 1 – 35 Offset

Index	Subindex	Data Type	Access	PDO Mapping	Value Range	Default Value	Description
2138	0	UINT8	RO	No	8	8	Number of subindexes
	1	UINT32	RW	No	0x0-0xFFFFFFFF	0x0	See Table 3
	2	UINT32	RW	No	0x0-0xFFFFFFFF	0x0	See Table 3
	3	UINT32	RW	No	0x0-0xFFFFFFFF	0x0	See Table 3
	4	UINT32	RW	No	0x0-0xFFFFFFFF	0x0	See Table 3
	5	UINT32	RW	No	0x0-0xFFFFFFFF	0x0	See Table 3
	6	UINT32	RW	No	0x0-0xFFFFFFFF	0x0	See Table 3
	7	UINT32	RW	No	0x0-0xFFFFFFFF	0x0	See Table 3
	8	UINT32	RW	No	0x0-0xFFFFFFFF	0x0	See Table 3
	9	UINT32	RW	No	0x0-0xFFFFFFFF	0x0	See Table 3
	10	UINT32	RW	No	0x0-0xFFFFFFFF	0x0	See Table 3
	11	UINT32	RW	No	0x0-0xFFFFFFFF	0x0	See Table 3
	12	UINT32	RW	No	0x0-0xFFFFFFFF	0x0	See Table 3
	13	UINT32	RW	No	0x0-0xFFFFFFFF	0x0	See Table 3

14	UINT32	RW	No	0x0-0xFFFFFFFF	0x0	See Table 3
15	UINT32	RW	No	0x0-0xFFFFFFFF	0x0	See Table 3
16	UINT32	RW	No	0x0-0xFFFFFFFF	0x0	See Table 3
17	UINT32	RW	No	0x0-0xFFFFFFFF	0x0	See Table 3
18	UINT32	RW	No	0x0-0xFFFFFFFF	0x0	See Table 3
19	UINT32	RW	No	0x0-0xFFFFFFFF	0x0	See Table 3
20	UINT32	RW	No	0x0-0xFFFFFFFF	0x0	See Table 3
21	UINT32	RW	No	0x0-0xFFFFFFFF	0x0	See Table 3
22	UINT32	RW	No	0x0-0xFFFFFFFF	0x0	See Table 3
23	UINT32	RW	No	0x0-0xFFFFFFFF	0x0	See Table 3
24	UINT32	RW	No	0x0-0xFFFFFFFF	0x0	See Table 3
25	UINT32	RW	No	0x0-0xFFFFFFFF	0x0	See Table 3
26	UINT32	RW	No	0x0-0xFFFFFFFF	0x0	See Table 3
27	UINT32	RW	No	0x0-0xFFFFFFFF	0x0	See Table 3
28	UINT32	RW	No	0x0-0xFFFFFFFF	0x0	See Table 3
29	UINT32	RW	No	0x0-0xFFFFFFFF	0x0	See Table 3
30	UINT32	RW	No	0x0-0xFFFFFFFF	0x0	See Table 3
31	UINT32	RW	No	0x0-0xFFFFFFFF	0x0	See Table 3
32	UINT32	RW	No	0x0-0xFFFFFFFF	0x0	See Table 3
33	UINT32	RW	No	0x0-0xFFFFFFFF	0x0	See Table 3
34	UINT32	RW	No	0x0-0xFFFFFFFF	0x0	See Table 3
35	UINT32	RW	No	0x0-0xFFFFFFFF	0x0	See Table 3

5.3.15 2139h LIN Signal 1 – 35 Initial value scalar

Index	Subindex	Data Type	Access	PDO Mapping	Value Range	Default Value	Description
2139	0	UINT8	RO	No	8	8	Number of subindexes
	1	UINT16	RW	No	0x0-0xFFFF	0x2	See Table 3
	2	UINT16	RW	No	0x0-0xFFFF	0x3	See Table 3

3	UINT16	RW	No	0x0-0xFFFF	0x4	See Table 3
4	UINT16	RW	No	0x0-0xFFFF	0x0	See Table 3
5	UINT16	RW	No	0x0-0xFFFF	0x1	See Table 3
6	UINT16	RW	No	0x0-0xFFFF	0x1	See Table 3
7	UINT16	RW	No	0x0-0xFFFF	0x1	See Table 3
8	UINT16	RW	No	0x0-0xFFFF	0x1	See Table 3
9	UINT16	RW	No	0x0-0xFFFF	0x1	See Table 3
10	UINT16	RW	No	0x0-0xFFFF	0x0	See Table 3
11	UINT16	RW	No	0x0-0xFFFF	0x0	See Table 3
12	UINT16	RW	No	0x0-0xFFFF	0x0	See Table 3
13	UINT16	RW	No	0x0-0xFFFF	0x0	See Table 3
14	UINT16	RW	No	0x0-0xFFFF	0x0	See Table 3
15	UINT16	RW	No	0x0-0xFFFF	0x0	See Table 3
16	UINT16	RW	No	0x0-0xFFFF	0x0	See Table 3
17	UINT16	RW	No	0x0-0xFFFF	0x0	See Table 3
18	UINT16	RW	No	0x0-0xFFFF	0x0	See Table 3
19	UINT16	RW	No	0x0-0xFFFF	0x0	See Table 3
20	UINT16	RW	No	0x0-0xFFFF	0x5	See Table 3
21	UINT16	RW	No	0x0-0xFFFF	0x6	See Table 3
22	UINT16	RW	No	0x0-0xFFFF	0x0	See Table 3
23	UINT16	RW	No	0x0-0xFFFF	0x0	See Table 3
24	UINT16	RW	No	0x0-0xFFFF	0x0	See Table 3
25	UINT16	RW	No	0x0-0xFFFF	0x0	See Table 3
26	UINT16	RW	No	0x0-0xFFFF	0x0	See Table 3
27	UINT16	RW	No	0x0-0xFFFF	0x0	See Table 3
28	UINT16	RW	No	0x0-0xFFFF	0x0	See Table 3
29	UINT16	RW	No	0x0-0xFFFF	0x0	See Table 3
30	UINT16	RW	No	0x0-0xFFFF	0x0	See Table 3
31	UINT16	RW	No	0x0-0xFFFF	0x0	See Table 3
32	UINT16	RW	No	0x0-0xFFFF	0x0	See Table 3
33	UINT16	RW	No	0x0-0xFFFF	0x0	See Table 3
34	UINT16	RW	No	0x0-0xFFFF	0x0	See Table 3
35	UINT16	RW	No	0x0-0xFFFF	0x0	See Table 3

5.3.16 2200h LIN Unconditional Frame 1 – 10 Kind

Index	Subindex	Data Type	Access	PDO Mapping	Value Range	Default Value	Description
2200	0	UINT8	RO	No	8	8	Number of subindexes
	1	UINT8	RW	No	0-2	1	See Table 5
	2	UINT8	RW	No	0-2	2	See Table 5
	3	UINT8	RW	No	0-2	0	See Table 5
	4	UINT8	RW	No	0-2	0	See Table 5
	5	UINT8	RW	No	0-2	0	See Table 5
	6	UINT8	RW	No	0-2	0	See Table 5
	7	UINT8	RW	No	0-2	0	See Table 5
	8	UINT8	RW	No	0-2	0	See Table 5
	9	UINT8	RW	No	0-2	0	See Table 5
10	UINT8	RW	No	0-2	0	See Table 5	

5.3.17 2201h LIN Unconditional Frame 1 – 10 ID

Index	Subindex	Data Type	Access	PDO Mapping	Value Range	Default Value	Description
2201	0	UINT8	RO	No	8	8	Number of subindexes
	1	UINT8	RW	No	0x0-0x3F	0x23	See Table 5
	2	UINT8	RW	No	0x0-0x3F	0x02	See Table 5
	3	UINT8	RW	No	0x0-0x3F	0	See Table 5
	4	UINT8	RW	No	0x0-0x3F	0	See Table 5
	5	UINT8	RW	No	0x0-0x3F	0	See Table 5
	6	UINT8	RW	No	0x0-0x3F	0	See Table 5
	7	UINT8	RW	No	0x0-0x3F	0	See Table 5
	8	UINT8	RW	No	0x0-0x3F	0	See Table 5
	9	UINT8	RW	No	0x0-0x3F	0	See Table 5
10	UINT8	RW	No	0x0-0x3F	0	See Table 5	

5.3.18 2202h LIN Unconditional Frame 1 – 10 Associated with event triggered frame

Index	Subindex	Data Type	Access	PDO Mapping	Value Range	Default Value	Description
2202	0	UINT8	RO	No	8	8	Number of subindexes
	1	UINT8	RW	No	0-1	0	See Table 5
	2	UINT8	RW	No	0-1	0	See Table 5
	3	UINT8	RW	No	0-1	0	See Table 5
	4	UINT8	RW	No	0-1	0	See Table 5
	5	UINT8	RW	No	0-1	0	See Table 5
	6	UINT8	RW	No	0-1	0	See Table 5
	7	UINT8	RW	No	0-1	0	See Table 5
	8	UINT8	RW	No	0-1	0	See Table 5
	9	UINT8	RW	No	0-1	0	See Table 5
10	UINT8	RW	No	0-1	0	See Table 5	

5.3.19 2203h LIN Unconditional Frame 1 – 10 Size

Index	Subindex	Data Type	Access	PDO Mapping	Value Range	Default Value	Description
2203	0	UINT8	RO	No	8	8	Number of subindexes
	1	UINT8	RW	No	1-8	5	See Table 5
	2	UINT8	RW	No	1-8	3	See Table 5
	3	UINT8	RW	No	1-8	1	See Table 5
	4	UINT8	RW	No	1-8	1	See Table 5
	5	UINT8	RW	No	1-8	1	See Table 5
	6	UINT8	RW	No	1-8	1	See Table 5
	7	UINT8	RW	No	1-8	1	See Table 5
	8	UINT8	RW	No	1-8	1	See Table 5
	9	UINT8	RW	No	1-8	1	See Table 5
10	UINT8	RW	No	1-8	1	See Table 5	

5.3.20 2210h LIN Unconditional Frame 1 Number 1 – 10

Index	Subindex	Data Type	Access	PDO Mapping	Value Range	Default Value	Description
2210	0	UINT8	RO	No	8	8	Number of subindexes
	1	UINT8	RW	No	0-35	5	See Table 5
	2	UINT8	RW	No	0-35	6	See Table 5
	3	UINT8	RW	No	0-35	7	See Table 5
	4	UINT8	RW	No	0-35	8	See Table 5
	5	UINT8	RW	No	0-35	9	See Table 5
	6	UINT8	RW	No	0-35	0	See Table 5
	7	UINT8	RW	No	0-35	0	See Table 5
	8	UINT8	RW	No	0-35	0	See Table 5
	9	UINT8	RW	No	0-35	0	See Table 5
	10	UINT8	RW	No	0-35	0	See Table 5

5.3.21 2211h LIN Unconditional Frame 1 Offset 1 – 10

Index	Subindex	Data Type	Access	PDO Mapping	Value Range	Default Value	Description
2211	0	UINT8	RO	No	8	8	Number of subindexes
	1	UINT8	RW	No	0-63	0	See Table 5
	2	UINT8	RW	No	0-63	8	See Table 5
	3	UINT8	RW	No	0-63	16	See Table 5
	4	UINT8	RW	No	0-63	24	See Table 5
	5	UINT8	RW	No	0-63	32	See Table 5
	6	UINT8	RW	No	0-63	0	See Table 5
	7	UINT8	RW	No	0-63	0	See Table 5
	8	UINT8	RW	No	0-63	0	See Table 5
	9	UINT8	RW	No	0-63	0	See Table 5
	10	UINT8	RW	No	0-63	0	See Table 5

5.3.22 2220h LIN Unconditional Frame 2 Number 1 – 10

Index	Subindex	Data Type	Access	PDO Mapping	Value Range	Default Value	Description
2220	0	UINT8	RO	No	8	8	Number of subindexes
	1	UINT8	RW	No	0-35	1	See Table 5
	2	UINT8	RW	No	0-35	2	See Table 5
	3	UINT8	RW	No	0-35	3	See Table 5
	4	UINT8	RW	No	0-35	0	See Table 5
	5	UINT8	RW	No	0-35	0	See Table 5
	6	UINT8	RW	No	0-35	0	See Table 5
	7	UINT8	RW	No	0-35	0	See Table 5
	8	UINT8	RW	No	0-35	0	See Table 5
	9	UINT8	RW	No	0-35	0	See Table 5
	10	UINT8	RW	No	0-35	0	See Table 5

5.3.23 2221h LIN Unconditional Frame 2 Offset 1 – 10

Index	Subindex	Data Type	Access	PDO Mapping	Value Range	Default Value	Description
2221	0	UINT8	RO	No	8	8	Number of subindexes
	1	UINT8	RW	No	0-63	0	See Table 5
	2	UINT8	RW	No	0-63	8	See Table 5
	3	UINT8	RW	No	0-63	16	See Table 5
	4	UINT8	RW	No	0-63	0	See Table 5
	5	UINT8	RW	No	0-63	0	See Table 5
	6	UINT8	RW	No	0-63	0	See Table 5
	7	UINT8	RW	No	0-63	0	See Table 5
	8	UINT8	RW	No	0-63	0	See Table 5
	9	UINT8	RW	No	0-63	0	See Table 5
10	UINT8	RW	No	0-63	0	See Table 5	

5.3.24 2230h, 2240h, 2250h, 2260h, 2270h, 2280h, 2290h, 22A0h LIN Unconditional Frame 3 – 10 Number 1 – 10

Index	Subindex	Data Type	Access	PDO Mapping	Value Range	Default Value	Description
2230 2240 2250 2260 2270 2280 2290 22A0	0	UINT8	RO	No	8	8	Number of subindexes
	1	UINT8	RW	No	0-35	0	See Table 5
	2	UINT8	RW	No	0-35	0	See Table 5
	3	UINT8	RW	No	0-35	0	See Table 5
	4	UINT8	RW	No	0-35	0	See Table 5
	5	UINT8	RW	No	0-35	0	See Table 5
	6	UINT8	RW	No	0-35	0	See Table 5
	7	UINT8	RW	No	0-35	0	See Table 5
	8	UINT8	RW	No	0-35	0	See Table 5
	9	UINT8	RW	No	0-35	0	See Table 5
10	UINT8	RW	No	0-35	0	See Table 5	

5.3.25 2231h, 2241h, 2251h, 2261h, 2271h, 2281h, 2291h, 22A1h LIN Unconditional Frame 3 – 10 Offset 1 – 10

Index	Subindex	Data Type	Access	PDO Mapping	Value Range	Default Value	Description
2231 2241 2251	0	UINT8	RO	No	8	8	Number of subindexes
	1	UINT8	RW	No	0-63	0	See Table 5

2261	2	UINT8	RW	No	0-63	0	See Table 5
2271	3	UINT8	RW	No	0-63	0	See Table 5
2281	4	UINT8	RW	No	0-63	0	See Table 5
2291	5	UINT8	RW	No	0-63	0	See Table 5
22A1	6	UINT8	RW	No	0-63	0	See Table 5
	7	UINT8	RW	No	0-63	0	See Table 5
	8	UINT8	RW	No	0-63	0	See Table 5
	9	UINT8	RW	No	0-63	0	See Table 5
	10	UINT8	RW	No	0-63	0	See Table 5

5.3.26 2300h LIN Event Triggered Frame Kind

Index	Subindex	Data Type	Access	PDO Mapping	Value Range	Default Value	Description
2300	0	UINT8	RW	No	0-2	0	See Table 6

5.3.27 2301h LIN Event Triggered Frame ID

Index	Subindex	Data Type	Access	PDO Mapping	Value Range	Default Value	Description
2301	0	UINT8	RW	No	0-3F	0	See Table 6

5.3.28 2302h LIN Event Triggered Frame Size

Index	Subindex	Data Type	Access	PDO Mapping	Value Range	Default Value	Description
2302	0	UINT8	RW	No	1-8	1	See Table 6

5.3.29 2303h LIN Event Triggered Frame Checksum Type

Index	Subindex	Data Type	Access	PDO Mapping	Value Range	Default Value	Description
2303	0	UINT8	RW	No	0-1	0	See Table 6

5.3.30 2304h LIN Event Triggered Frame Collision Resolving Schedule Table Number

Index	Subindex	Data Type	Access	PDO Mapping	Value Range	Default Value	Description
2304	0	UINT8	RW	No	0-1	0	See Table 6

5.3.31 2310h LIN Event Triggered Frame Unconditional Frame Number

Index	Subindex	Data Type	Access	PDO Mapping	Value Range	Default Value	Description
2310	0	UINT8	RO	No	5	5	Number of subindexes
	1	UINT8	RW	No	0-10	0	See Table 6
	2	UINT8	RW	No	0-10	0	See Table 6
	3	UINT8	RW	No	0-10	0	See Table 6
	4	UINT8	RW	No	0-10	0	See Table 6
	5	UINT8	RW	No	0-10	0	See Table 6

5.3.32 2400h LIN Sporadic Frame Kind

Index	Subindex	Data Type	Access	PDO Mapping	Value Range	Default Value	Description
2400	0	UINT8	RW	No	0-2	0	See Table 7

5.3.33 2410h LIN Sporadic Frame Unconditional Frame Number

Index	Subindex	Data Type	Access	PDO Mapping	Value Range	Default Value	Description
2410	0	UINT8	RO	No	5	5	Number of subindexes
	1	UINT8	RW	No	0-10	0	See Table 7
	2	UINT8	RW	No	0-10	0	See Table 7
	3	UINT8	RW	No	0-10	0	See Table 7
	4	UINT8	RW	No	0-10	0	See Table 7
	5	UINT8	RW	No	0-10	0	See Table 7

5.3.34 2500h LIN Main Schedule Type

Index	Subindex	Data Type	Access	PDO Mapping	Value Range	Default Value	Description
2500	0	UINT8	RO	No	5	5	Number of subindexes
	1	UINT8	RW	No	0-3	1	See Table 8
	2	UINT8	RW	No	0-3	1	See Table 8
	3	UINT8	RW	No	0-3	0	See Table 8
	4	UINT8	RW	No	0-3	0	See Table 8
	5	UINT8	RW	No	0-3	0	See Table 8
	6	UINT8	RW	No	0-3	0	See Table 8
	7	UINT8	RW	No	0-3	0	See Table 8
	8	UINT8	RW	No	0-3	0	See Table 8
	9	UINT8	RW	No	0-3	0	See Table 8
	10	UINT8	RW	No	0-3	0	See Table 8

5.3.35 2501h LIN Main Schedule Number

Index	Subindex	Data Type	Access	PDO Mapping	Value Range	Default Value	Description
2501	0	UINT8	RO	No	5	5	Number of subindexes
	1	UINT8	RW	No	Depends on Frame Type	1	See Table 8
	2	UINT8	RW	No	Depends on Frame Type	2	See Table 8
	3	UINT8	RW	No	Depends on Frame Type	0	See Table 8
	4	UINT8	RW	No	Depends on Frame Type	0	See Table 8
	5	UINT8	RW	No	Depends on Frame Type	0	See Table 8
	6	UINT8	RW	No	Depends on Frame Type	0	See Table 8

	7	UINT8	RW	No	Depends on Frame Type	0	See Table 8
	8	UINT8	RW	No	Depends on Frame Type	0	See Table 8
	9	UINT8	RW	No	Depends on Frame Type	0	See Table 8
	10	UINT8	RW	No	Depends on Frame Type	0	See Table 8

5.3.36 2502h LIN Main Schedule Delay

Index	Subindex	Data Type	Access	PDO Mapping	Value Range	Default Value	Description
2502	0	UINT8	RO	No	5	5	Number of subindexes
	1	UINT16	RW	No	0-10000	50	See Table 8
	2	UINT16	RW	No	0-10000	60	See Table 8
	3	UINT16	RW	No	0-10000	0	See Table 8
	4	UINT16	RW	No	0-10000	0	See Table 8
	5	UINT16	RW	No	0-10000	0	See Table 8
	6	UINT16	RW	No	0-10000	0	See Table 8
	7	UINT16	RW	No	0-10000	0	See Table 8
	8	UINT16	RW	No	0-10000	0	See Table 8
	9	UINT16	RW	No	0-10000	0	See Table 8
	10	UINT16	RW	No	0-10000	0	See Table 8

5.3.37 2600h LIN Collision Schedule Type

Index	Subindex	Data Type	Access	PDO Mapping	Value Range	Default Value	Description
2600	0	UINT8	RO	No	5	5	Number of subindexes
	1	UINT8	RW	No	0-3	0	See Table 9
	2	UINT8	RW	No	0-3	0	See Table 9
	3	UINT8	RW	No	0-3	0	See Table 9
	4	UINT8	RW	No	0-3	0	See Table 9
	5	UINT8	RW	No	0-3	0	See Table 9

5.3.38 2601h LIN Collision Schedule Number

Index	Subindex	Data Type	Access	PDO Mapping	Value Range	Default Value	Description
2601	0	UINT8	RO	No	5	5	Number of subindexes
	1	UINT8	RW	No	0-10	0	See Table 9
	2	UINT8	RW	No	0-10	0	See Table 9
	3	UINT8	RW	No	0-10	0	See Table 9
	4	UINT8	RW	No	0-10	0	See Table 9
	5	UINT8	RW	No	0-10	0	See Table 9

5.3.39 2602h LIN Collision Schedule Delay

Index	Subindex	Data Type	Access	PDO Mapping	Value Range	Default Value	Description
2602	0	UINT8	RO	No	5	5	Number of subindexes
	1	UINT16	RW	No	0-10000	0	See Table 9

	2	UINT16	RW	No	0-10000	0	See Table 9
	3	UINT16	RW	No	0-10000	0	See Table 9
	4	UINT16	RW	No	0-10000	0	See Table 9
	5	UINT16	RW	No	0-10000	0	See Table 9

5.3.40 2700h Global Parameter Continuous Signal

Index	Subindex	Data Type	Access	PDO Mapping	Value Range	Default Value	Description
2700	0	UINT32	RW	No	0x0-0xFFFFFFFF	0	See Table 13

5.3.41 2701h Global Parameter Discrete Signal

Index	Subindex	Data Type	Access	PDO Mapping	Value Range	Default Value	Description
2701	0	UINT32	RW	No	0x0-0xFFFFFFFF	0	See Table 13

5.3.42 3010h – 30F0 Binary Function Input Source

Index	Subindex	Data Type	Access	PDO Mapping	Value Range	Default Value	Description
3010, 3020, 3030	0	UINT8	RW	No	2	2	Number of subindexes
3040, 3050, 3060	1	UINT8	RW	No	0-65	0	
3070, 3080, 3090 30A0, 30B0, 30C0 30D0, 30E0, 30F0	2	UINT8	RW	No	0-65	0	

5.3.43 3011h – 30F1 Binary Function Is Signal Default

Index	Subindex	Data Type	Access	PDO Mapping	Value Range	Default Value	Description
3011, 3021, 3031	0	UINT8	RW	No	2	2	Number of subindexes
3041, 3051, 3061	1	UINT8	RW	No	0-1	0	
3071, 3081, 3091 30A1, 30B1, 30C1 30D1, 30E1, 30F1	2	UINT8	RW	No	0-1	0	

5.3.44 3012h – 30F2 Binary Function Default Value

Index	Subindex	Data Type	Access	PDO Mapping	Value Range	Default Value	Description
3012, 3022, 3032	0	UINT8	RW	No	2	2	Number of subindexes
3042, 3052, 3062 3072, 3082, 3092	1	UINT8	RW	No	0x0-0xFFFFFFFF	0	
30A2, 30B2, 30C2 30D2, 30E2, 30F2	2	UINT8	RW	No	0x0-0xFFFFFFFF	0	

5.3.45 3013h – 30F3 Binary Function Unary Function

Index	Subindex	Data Type	Access	PDO Mapping	Value Range	Default Value	Description
3013, 3023, 3033	0	UINT8	RW	No	2	2	Number of subindexes
3043, 3053, 3063	1	FLOAT32	RW	No	Any value	0	See Table 10
3073, 3083, 3093 30A3, 30B3, 30C3 30D3, 30E3, 30F3	2	FLOAT32	RW	No	Any value	0	See Table 10

5.3.46 3014h – 30F4 Binary Function Scale

Index	Subindex	Data Type	Access	PDO Mapping	Value Range	Default Value	Description
3014, 3024, 3034	0	UINT8	RW	No	2	2	Number of subindexes
3044, 3054, 3064	1	FLOAT32	RW	No	Any value	0	
3074, 3084, 3094 30A4, 30B4, 30C4 30D4, 30E4, 30F4	2	FLOAT32	RW	No	Any value	0	

5.3.47 3015h – 30F5 Binary Function Offset

Index	Subindex	Data Type	Access	PDO Mapping	Value Range	Default Value	Description
3015, 3025, 3035	0	UINT8	RW	No	2	2	Number of subindexes
3045, 3055, 3065	1	FLOAT32	RW	No	Any value	0	
3075, 3085, 3095 30A5, 30B5, 30C5 30D5, 30E5, 30F5	2	FLOAT32	RW	No	Any value	0	

5.3.48 300Ah Binary Function Output Operation

Index	Subindex	Data Type	Access	PDO Mapping	Value Range	Default Value	Description
300A	0	UINT8	RO	No	5	5	Number of subindexes
	1	UINT8	RW	No	0-20	0	See Table 12
	2	UINT8	RW	No	0-20	0	See Table 12
	3	UINT8	RW	No	0-20	0	See Table 12
	4	UINT8	RW	No	0-20	0	See Table 12
	5	UINT8	RW	No	0-20	0	See Table 12
	6	UINT8	RW	No	0-20	0	See Table 12
	7	UINT8	RW	No	0-20	0	See Table 12
	8	UINT8	RW	No	0-20	0	See Table 12
	9	UINT8	RW	No	0-20	0	See Table 12
	10	UINT8	RW	No	0-20	0	See Table 12
	11	UINT8	RW	No	0-20	0	See Table 12
	12	UINT8	RW	No	0-20	0	See Table 12
	13	UINT8	RW	No	0-20	0	See Table 12
	14	UINT8	RW	No	0-20	0	See Table 12
15	UINT8	RW	No	0-20	0	See Table 12	

5.3.49 300Bh Binary Function Output Scaling

Index	Subindex	Data Type	Access	PDO Mapping	Value Range	Default Value	Description
300B	0	UINT8	RO	No	5	5	Number of subindexes
	1	FLOAT32	RW	No	Any value	0	
	2	FLOAT32	RW	No	Any value	0	
	3	FLOAT32	RW	No	Any value	0	
	4	FLOAT32	RW	No	Any value	0	
	5	FLOAT32	RW	No	Any value	0	
	6	FLOAT32	RW	No	Any value	0	
	7	FLOAT32	RW	No	Any value	0	
	8	FLOAT32	RW	No	Any value	0	
	9	FLOAT32	RW	No	Any value	0	
	10	FLOAT32	RW	No	Any value	0	
	11	FLOAT32	RW	No	Any value	0	
	12	FLOAT32	RW	No	Any value	0	
	13	FLOAT32	RW	No	Any value	0	
	14	FLOAT32	RW	No	Any value	0	
	15	FLOAT32	RW	No	Any value	0	

5.3.50 300Ch Binary Function Output Offset

Index	Subindex	Data Type	Access	PDO Mapping	Value Range	Default Value	Description
300C	0	UINT8	RO	No	5	5	Number of subindexes
	1	FLOAT32	RW	No	Any value	0	
	2	FLOAT32	RW	No	Any value	0	
	3	FLOAT32	RW	No	Any value	0	
	4	FLOAT32	RW	No	Any value	0	
	5	FLOAT32	RW	No	Any value	0	
	6	FLOAT32	RW	No	Any value	0	
	7	FLOAT32	RW	No	Any value	0	
	8	FLOAT32	RW	No	Any value	0	
	9	FLOAT32	RW	No	Any value	0	
	10	FLOAT32	RW	No	Any value	0	
	11	FLOAT32	RW	No	Any value	0	
	12	FLOAT32	RW	No	Any value	0	
	13	FLOAT32	RW	No	Any value	0	
	14	FLOAT32	RW	No	Any value	0	
	15	FLOAT32	RW	No	Any value	0	

5.3.51 4000h Global VPS Data

Index	Subindex	Data Type	Access	PDO Mapping	Value Range	Default Value	Description
4000	0	REAL32	RW	Yes	Any value	0	

5.3.52 4001h Global Temperature Data

Index	Subindex	Data Type	Access	PDO Mapping	Value Range	Default Value	Description
4001	0	REAL32	RW	Yes	Any value	0	

5.3.53 4002h LIN Data Data

Index	Subindex	Data Type	Access	PDO Mapping	Value Range	Default Value	Description
4002	0	UINT8	RO	Yes	8	8	Number of subindexes
	1	INT16	RW	Yes	0x-0xFFFFFFFF	0	
	2	INT16	RW	Yes	0x-0xFFFFFFFF	0	
	3	INT16	RW	Yes	0x-0xFFFFFFFF	0	
	4	INT16	RW	Yes	0x-0xFFFFFFFF	0	
	5	INT16	RW	Yes	0x-0xFFFFFFFF	5	
	6	INT16	RW	Yes	0x-0xFFFFFFFF	6	
	7	INT16	RW	Yes	0x-0xFFFFFFFF	7	
	8	INT16	RW	Yes	0x-0xFFFFFFFF	8	
	9	INT16	RW	Yes	0x-0xFFFFFFFF	9	
	10	INT16	RW	Yes	0x-0xFFFFFFFF	0	
	11	INT16	RW	Yes	0x-0xFFFFFFFF	0	
	12	INT16	RW	Yes	0x-0xFFFFFFFF	0	
	13	INT16	RW	Yes	0x-0xFFFFFFFF	0	
	14	INT16	RW	Yes	0x-0xFFFFFFFF	0	
	15	INT16	RW	Yes	0x-0xFFFFFFFF	0	
	16	INT16	RW	Yes	0x-0xFFFFFFFF	0	
	17	INT16	RW	Yes	0x-0xFFFFFFFF	0	
	18	INT16	RW	Yes	0x-0xFFFFFFFF	0	
	19	INT16	RW	Yes	0x-0xFFFFFFFF	0	
	20	INT16	RW	Yes	0x-0xFFFFFFFF	0	
	21	INT16	RW	Yes	0x-0xFFFFFFFF	0	
	22	INT16	RW	Yes	0x-0xFFFFFFFF	0	
	23	INT16	RW	Yes	0x-0xFFFFFFFF	0	
	24	INT16	RW	Yes	0x-0xFFFFFFFF	0	
	25	INT16	RW	Yes	0x-0xFFFFFFFF	0	
	26	INT16	RW	Yes	0x-0xFFFFFFFF	0	
	27	INT16	RW	Yes	0x-0xFFFFFFFF	0	
	28	INT16	RW	Yes	0x-0xFFFFFFFF	0	
	29	INT16	RW	Yes	0x-0xFFFFFFFF	0	
	30	INT16	RW	Yes	0x-0xFFFFFFFF	0	
	31	INT16	RW	Yes	0x-0xFFFFFFFF	0	
	32	INT16	RW	Yes	0x-0xFFFFFFFF	0	
	33	INT16	RW	Yes	0x-0xFFFFFFFF	0	
	34	INT16	RW	Yes	0x-0xFFFFFFFF	0	
35	INT16	RW	Yes	0x-0xFFFFFFFF	0		

5.3.54 4003h Extra CANopen Data Signal

Index	Subindex	Data Type	Access	PDO Mapping	Value Range	Default Value	Description
-------	----------	-----------	--------	-------------	-------------	---------------	-------------

4003	0	UINT8	RO	Yes	8	8	Number of subindexes
	1	UINT32	RW	Yes	0x-0xFFFFFFFF	0	
	2	UINT32	RW	Yes	0x-0xFFFFFFFF	0	
	3	UINT32	RW	Yes	0x-0xFFFFFFFF	0	
	4	UINT32	RW	Yes	0x-0xFFFFFFFF	0	
	5	UINT32	RW	Yes	0x-0xFFFFFFFF	5	

5.3.55 4004h LIN Driver Status

Index	Subindex	Data Type	Access	PDO Mapping	Value Range	Default Value	Description
4004	0	UINT8	RO	No	0-16	0	LIN Driver Status for Debugging purposes

5.3.56 4005h LIN Driver Slave Error

Index	Subindex	Data Type	Access	PDO Mapping	Value Range	Default Value	Description
4005	0	UINT8	RO	No	0-16	0	LIN Driver Slave Error for Debugging purposes

5.3.57 5555h Start in Operational Mode

Index	Subindex	Data Type	Access	PDO Mapping	Value Range	Default Value	Description
5555	0	UINT8	RW	No	0-1	0	

5.3.58 55AAh Start Bootloader

Index	Subindex	Data Type	Access	PDO Mapping	Value Range	Default Value	Description
55AA	0	UINT8	RW	No	0-1	0	Start in operational mode to update firmware.

5.3.59 5B50h Change Baud Rate

Index	Subindex	Data Type	Access	PDO Mapping	Value Range	Default Value	Description
5B50	0	UINT8	RW	No	0-9	0	

5.3.60 5B51h Change Node ID

Index	Subindex	Data Type	Access	PDO Mapping	Value Range	Default Value	Description
5B51	0	UINT8	RW	No	0-9	0	Power circle unit after set new Baud Rate

6 TECHNICAL SPECIFICATIONS

Typical at nominal input voltage and 25 degrees C unless otherwise specified.

6.1 Power

Table 22. Power

Power Supply Input	12 V or 24 Vdc nominal; 9...32 Vdc
Surge Protection	Meets the surge requirements of SAE J1445
Reverse Polarity Protection	Provided

6.2 Control Software

Table 23. Control Software

Software Platform	The Protocol Converter comes pre-programmed with customer specific protocol conversion logic for data exchange between 1 LIN network and 1 CANopen network (CiA).
-------------------	---

6.3 General Specifications

Table 24. General Specifications

Microprocessor	32-bit, 128 KByte flash program memory
LIN Port	1 LIN (LIN 2.2)
CAN Port	1 CAN (CANopen, 125 kbit/s)
Power Supply Current	40 mA @ 12V
Operating Conditions	-40 to 85 °C (-40 to 185 °F)
Weight	0.15 lbs. (0.068 kg)
Protection Rating	IP67
Vibration	Random Vibration: 7.68 Grms peak Sinusoidal Component: 10 g peak Based on MIL-STD-202G, Methods 204G and 214A
Shock	50 g half sine pulse, 9ms per axis Based on MIL-STD-202G, Method 213B, Test Condition A
Enclosure and Dimensions	Plastic Enclosure, Nylon 6-6 with 30% glass fill Integral Deutsch IPD connector Refer to dimensional drawing (below).

Electrical Connections	<p>6 pin Deutsch IPD connector P/N: DT04-6P A mating plug kit is available as Axiomatic P/N: AX070119</p> <table border="1" data-bbox="565 262 1003 590"> <thead> <tr> <th colspan="2">CAN and I/O Connector</th> </tr> <tr> <th>PIN #</th> <th>Description</th> </tr> </thead> <tbody> <tr> <td>1</td> <td>CAN_SH (shield)</td> </tr> <tr> <td>2</td> <td>CAN_L</td> </tr> <tr> <td>3</td> <td>CAN_H</td> </tr> <tr> <td>4</td> <td>LIN</td> </tr> <tr> <td>5</td> <td>BATT+</td> </tr> <tr> <td>6</td> <td>BATT-</td> </tr> </tbody> </table>	CAN and I/O Connector		PIN #	Description	1	CAN_SH (shield)	2	CAN_L	3	CAN_H	4	LIN	5	BATT+	6	BATT-
CAN and I/O Connector																	
PIN #	Description																
1	CAN_SH (shield)																
2	CAN_L																
3	CAN_H																
4	LIN																
5	BATT+																
6	BATT-																
Software Reflashing	Electronic Assistant AX070502																
User Interface	<p>Parameters are configurable using the Electronic Assistant.</p> <p>Axiomatic Electronic Assistant P/N: AX070502 The Electronic Assistant for Windows operating systems comes with a royalty free license for use on multiple computers. It requires an Axiomatic USB-CAN converter to link the device's CAN port to a Windows-based PC.</p>																

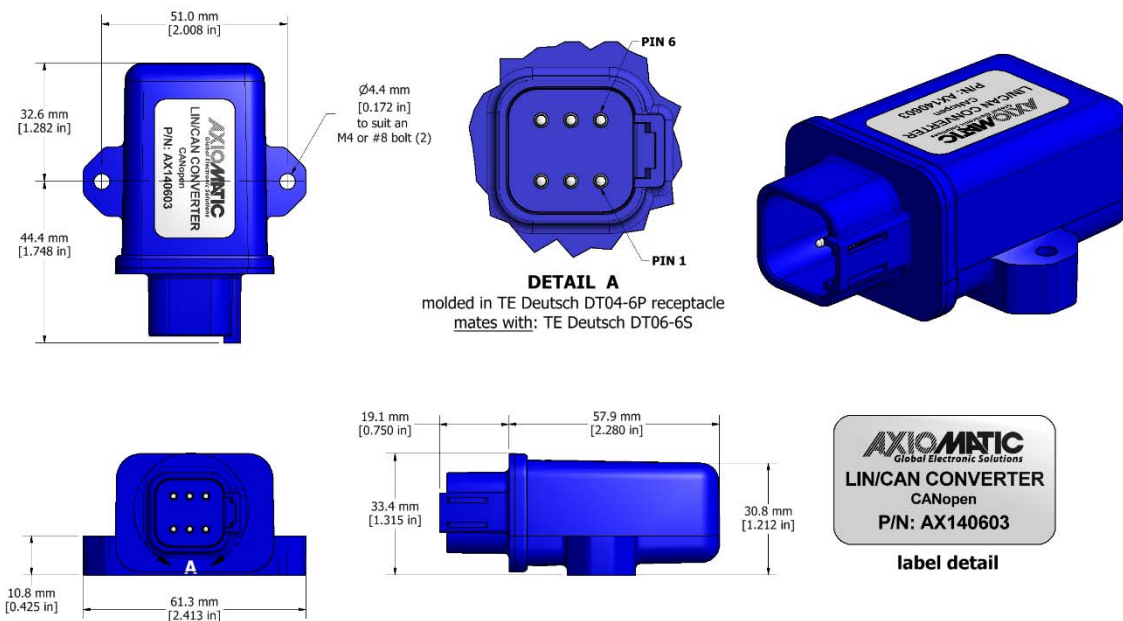

Figure 17. Unit Dimensions



OUR PRODUCTS

Actuator Controls
Battery Chargers
CAN bus Controls, Gateways
CAN/Wifi, CAN/Bluetooth
CAN/Ethernet
Current Converters
DC/DC Power Converters
DC Voltage/Current Signal Converters
Engine Temperature Scanners
Ethernet/CAN Converters
Fan Drive Controllers
Hydraulic Valve Controllers
I/O Controls
LVDT Simulators
Machine Controls
Motor Controls
PID Controls
Position Sensors, Angle Measurement Inclinometers, Gyroscopes
Power Supplies
PWM Signal Converters/Isolators
Resolver Signal Conditioners
Service Tools
Signal Conditioners
Strain Gauge CAN Controls
Surge Suppressors

OUR COMPANY

Axiomatic provides electronic machine controls, components, and systems to the off-highway, commercial vehicle, electric vehicle, power generator set, material handling, renewable energy and industrial OEM markets.

We provide efficient, innovative solutions that focus on adding value for our customers.

We emphasize service and partnership with our customers, suppliers, and employees to build long term relationships and mutual trust.

QUALITY DESIGN AND MANUFACTURING

Axiomatic is an ISO 9001:2015 registered facility.

SERVICE

All products to be returned to Axiomatic require a Return Materials Authorization Number (RMA#).

Please provide the following information when requesting an RMA number:

- Serial number, part number
- Axiomatic invoice number and date
- Hours of operation, description of problem
- Wiring set up diagram, application
- Other comments as needed

When preparing the return shipping paperwork, please note the following. The commercial invoice for customs (and packing slip) should state the harmonized international HS (tariff code), valuation and return goods terminology, as shown in italics below. The value of the units on the commercial invoice should be identical to their purchase price.

*Goods Made In Canada (or Finland)
Returned Goods for Warranty Evaluation, HS: 9813.00
Valuation Identical Goods
Axiomatic RMA#*

WARRANTY, APPLICATION APPROVALS/LIMITATIONS

Axiomatic Technologies Corporation reserves the right to make corrections, modifications, enhancements, improvements, and other changes to its products and services at any time and to discontinue any product or service without notice. Customers should obtain the latest relevant information before placing orders and should verify that such information is current and complete. Users should satisfy themselves that the product is suitable for use in the intended application. All our products carry a limited warranty against defects in material and workmanship. Please refer to our Warranty, Application Approvals/Limitations and Return Materials Process as described on www.axiomatic.com/service.html.

CONTACTS

Axiomatic Technologies Corporation
5915 Wallace Street
Mississauga, ON
CANADA L4Z 1Z8
TEL: +1 905 602 9270
FAX: +1 905 602 9279
www.axiomatic.com

Axiomatic Technologies Oy
Höytämöntie 6
33880 Lempäälä
FINLAND
TEL: +358 103 375 750
FAX: +358 3 3595 660
www.axiomatic.fi