



User Manual UMAX140940  
Version 1  
Firmware 1.xx

# USER MANUAL

## CAN to Modbus TCP/IP Converter

P/N: AX140940

**In Europe:**  
Axiomatic Technologies Oy  
Höytämöntie 6  
33880 Lempäälä - Finland  
Tel. +358 103 375 750  
Fax. +358 3 3595 660  
[www.axiomatic.fi](http://www.axiomatic.fi)

**In North America:**  
Axiomatic Technologies Corporation  
5915 Wallace Street  
Mississauga, ON Canada L4Z 1Z8  
Tel. 1 905 602 9270  
Fax. 1 905 602 9279  
[www.axiomatic.com](http://www.axiomatic.com)

## VERSION HISTORY

<b>Version</b>	<b>Date</b>	<b>Author</b>	<b>Modification</b>
1.0	September 30 <sup>st</sup> , 2021	Meera Patel	Initial Draft for Rev 1 hardware
1.1	March 8 <sup>th</sup> , 2022	Meera Patel	Solved the Bug of CAN RX message ON/OFF Added Standard ID CAN Messages for CAN Rx. Added CAN Shared PGN support for CAN Tx.

## ACRONYMS

A	Ampere
ACK	Positive Acknowledgement (from SAE J1939 standard)
ARP	Address Resolution Protocol
°C	Celsius (degree)
CAN	Controller Area Network
CE	Conformité Européenne (European Conformity)
CM	Conversion Method
DM	Diagnostic Message (from SAE J1939 standard)
DTC	Diagnostic Trouble Code (from SAE J1939 standard)
EA	Electronic Assistant <sup>®</sup> . PC application software from Axiomatic
ECU	Electronic Control Unit (from SAE J1939 standard)
EEPROM	Electrically Erasable Programmable Read-Only Memory
EMC	Electromagnetic Compatibility
ESD	Electrostatic Discharge
FCC	Federal Communications Commission
FMI	Failure Mode Identifier
G	Acceleration in Gravity Units
GPL	General Public License
hr	hour
HTTP	Hypertext Transfer Protocol
ICMP	Internet Control Message Protocol
ID	Identifier
IEC	International Electrotechnical Commission
IP	Internet Protocol or Ingress Protection (for housing)
ISO	International Organization for Standardization
OC	Occurrence Count
L	Length (for size)
LAN	Local Area Network
LED	Light-Emitting Diode
m	meters
MAC	Media Access Control (address)
MDIX	Medium Dependent Interface Crossover (MDI-X)
Ms	Millisecond
NAK	Negative Acknowledgement (from SAE J1939 standard)
PA	Polyamide
PDU1	A format for messages that are to be sent to a destination address, either specific or global (from SAE J1939 standard)
PDU2	A format used to send information that has been labeled using the Group Extension technique and does not contain a destination address.
PHY	Physical Layer Transceiver (Ethernet chip)
P/N	Part Number
PoE	Power Over Ethernet
RoHS	Restriction of Hazardous Substances
RTOS	Real-Time Operating System

SP	Service Pack
SPN	Suspect Parameter Number (SAE J1939)
SW	Software
TCP	Transmission Control Protocol
UDP/IP	User Datagram Protocol / Internet Protocol
UL	Underwriters Laboratories (safety organization)
USB	Universal Serial Bus
V	Volt
VDC	Volt Direct Current
W	Watt or Width (for size)
WAN	Wide Area Network

## TABLE OF CONTENTS

1. CONVERTER DESCRIPTION.....	6
1.1 Hardware Block Diagram.....	6
1.2 LED Indicators.....	7
1.3 Firmware Organization.....	7
1.3.1 Communication Device.....	8
1.3.1.1 TCP/IP Protocol.....	8
1.3.2 Web Server.....	8
1.3.3 Firmware Updates.....	8
2 CONVERTER CONFIGURATION.....	9
2.1 Changing Configuration Parameters.....	11
2.2 Ethernet Configuration.....	13
2.3 CAN Configuration.....	14
2.3.1 CAN Rx Configuration / can_rx_settings.html.....	14
2.3.2 CAN Tx Configuration / can_tx_settings.html.....	16
3 Modbus TCP/IP Settings.....	18
3.1 Modbus TCP/IP Master Settings.....	19
3.2 Diagnostics Routing.....	20
3.3 Upload/Download Settings.....	21
4 FIRMWARE UPDATE.....	22
4.1 Uploading the New Firmware.....	22
4.2 Applying the New Firmware.....	23
5 CONVERTER DEPLOYMENT.....	25
5.1 CAN Network Synchronization.....	25
5.1.1 Hardware Setup.....	25
5.1.2 Converter Configuration.....	26
5.1.2.1 Server Configuration.....	26
5.1.2.2 Client Configuration.....	27
6 TECHNICAL SPECIFICATIONS.....	30
6.1 Power Supply.....	30
6.1.1 Input.....	30
6.1.2 Output.....	30
6.2 Ethernet.....	30
6.2.1 Ethernet Connector.....	31
6.3 CAN.....	31
6.3.1 CAN Connector.....	31
6.4 General Specifications.....	32
6.5 Accessories.....	32
6.6 Housing.....	33
7 THIRD PARTY SOFTWARE LICENSE NOTICES.....	34

## 1. CONVERTER DESCRIPTION

The CAN to Modbus TCP/IP Converter is a simple device converting CAN frames into MODBUS TCP/IP datagrams and sending them over the Ethernet network. The device can also convert Modbus TCP/IP datagrams into CAN frames.

The converter has one CAN and one Ethernet port. It supports a high-speed CAN with baud rate up to 1Mbit/s and a fast 100Mbit/s Ethernet. All standard and extended CAN frames, including data and remote frames, are supported.

The power can be passed to the successive device through the Pout Pin. Protection is provided.

The converter contains a web server to setup configuration parameters and monitor the internal state of the converter using a web browser. The user can also update the converter firmware using the web browser.

To ensure low latency in processing CAN and Ethernet messages, the converter software runs under control of a real-time operating system.

The converter is designed to work on off-road machinery or in a harsh industrial environment with power transients, high humidity, and vibrations.

### 1.1 Hardware Block Diagram

The converter hardware block diagram is presented in Figure 1.

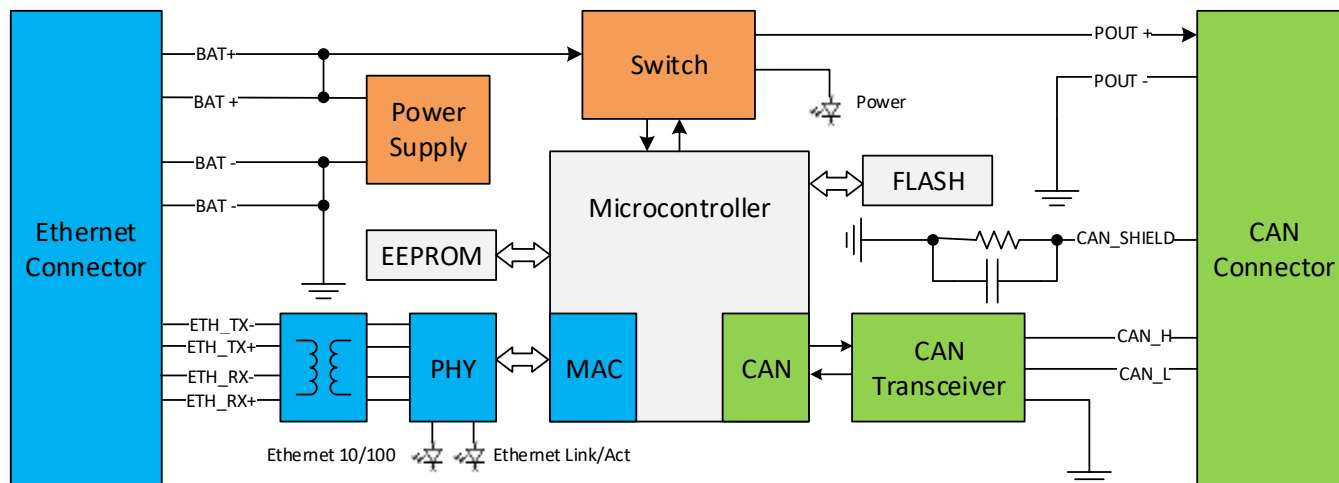

Figure 1. The Converter Hardware Block Diagram

The converter is powered from the Ethernet connector using dedicated power lines. The power from the Ethernet connector can be delivered to the CAN connector through a switch controlled by a microcontroller.

The Ethernet transformers with PHY, together with the CAN transceiver, provide Ethernet and CAN physical interfaces.

A powerful ARM Cortex-M4 microcontroller runs IP protocol stack and all Ethernet to CAN conversion logic.

## 1.2 LED Indicators

There are three LED indicators on the front panel of the converter. A bi-color “Power” indicator shows whether the unit is powered. It turns red when there is an error on the CAN power output.

The two Ethernet LED indicators are hardwired to the PHY chip and show the transmission speed “Ethernet 10/100” and the link/activity status “Ethernet Link/Act”, see Table 1:

Table 1. Converter LED Indicators

Name	Color	Description	
Power	Green/Red	Off	The converter is not powered.
		Green	The converter is powered. CAN Power Output is in normal condition.
		Red	CAN Power Output is in a fault condition.
Ethernet 10/100	Green	On	Ethernet speed is 100 Mbit/s
		Off	Ethernet speed is 10 Mbit/s
Ethernet Link/Act	Green	On	Ethernet link is up
		Off	Ethernet link is down
		Blinking	Ethernet link is up and active

## 1.3 Firmware Organization

The Ethernet to CAN Converter firmware contains two independent parts: the *Communication Device* and the *Web Server*, see Figure 2:

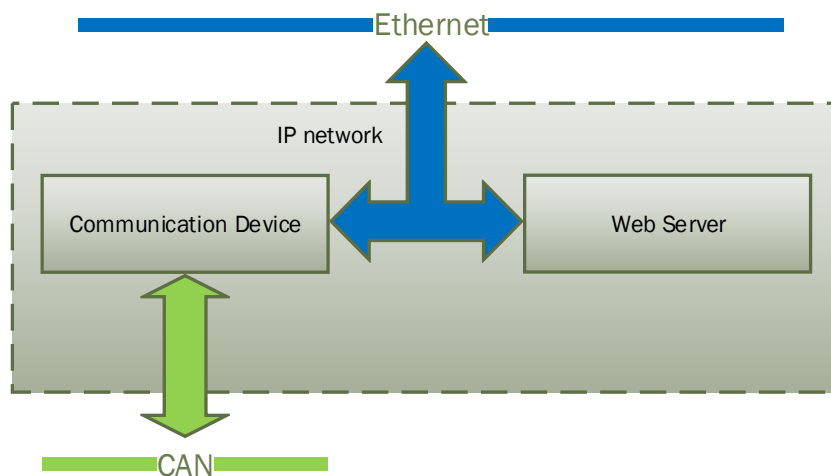

Figure 2. Converter Firmware Architecture

The *Communication Device* is responsible for the protocol conversion between CAN and Ethernet networks and the *Web Server* provides the converter user interface.

Both the *Communication Device* and the *Web Server* use the same IP network interface. The IP address resolution is provided by the ARP protocol.

### **1.3.1 Communication Device**

The *Communication Device* supports a master/slave communication model to communicate CAN messages and other auxiliary information over the Ethernet. In this model, the *Communication Device* has a primary slave role, allowing external clients to establish independent connections with the device.

In addition to the slave role, the device can also act as a master, if the *Ethernet Master Enabled* configuration parameter is set to *YES*. In this case, the device will try to establish a connection with a customer specified slave device.

The *Communication Device* uses Modbus TCP/IP protocol, The value of the *Device Port* for Modbus TCP/IP will be always 502, as it is reserved for Modbus TCP/IP Communication.

#### **1.3.1.1 TCP/IP Protocol**

Modbus TCP/IP provides Master (Client) -Slave (Server) communication over Ethernet.

The server side opens a listening socket for incoming connections. Once a connection is accepted, a new data socket is created to handle input/output communication with the remote node. There are no restrictions on the IP address for the incoming connections.

On the client side, if "*Ethernet Master Enabled*" is set to *YES*, a data socket is created for connection with the Slave (Server) node. The port number is assigned to the socket which is 502. If the connection drops, the device will try to automatically reconnect with the node to maintain the client connection, if a hardware reset is provided to the device and if the device is working as a Server (Slave), then a webserver refresh is needed to connect again.

### **1.3.2 Web Server**

The *Web Server* provides a user front-end interface with the converter. It runs a dynamic website that shows: the converter general information, configuration parameters, and the converter real-time diagnostics.

The user can also change configuration parameters and upload the new firmware through this website.

The web browser should support JavaScript.

### **1.3.3 Firmware Updates**

The firmware can be remotely updated through the web server.

## 2 CONVERTER CONFIGURATION

---

The converter supports configuration over the internal website running on the device embedded web server. The default “*Device IP Address*” is *192.168.1.25* and the default *Web Server Port* is *80*. Please, make sure that there are no other devices on this IP address when connecting the converter for the first time to your LAN for configuration.

To connect to the device, run any web browser and point it to the “*Device IP Address*”. It is not necessary to specify the “*Web Server Port*” if the web server uses a standard port *80*.

After a successful connection, you will see the device home page, see: Figure 3. Converter Home Page3.

The screenshot shows a web browser window with the address bar displaying "AX140940 Home" and "192.168.1.25". The page title is "AXOMATIC Global Electronic Solutions CAN - ModbusTCP/IP Converter". On the left, there is a navigation menu with the following items:

- [Home](#)
- [Main Settings](#)
- [CAN RX Settings](#)
- [CAN TX Settings](#)
- [Modbus Slave Settings](#)
- [Modbus Master Settings](#)
- [Diagnostics Routing](#)
- [Upload/Download Settings](#)
- [Firmware](#)

The main content area is divided into several sections:

- DEVICE INFORMATION**: Part Number: AX140940, Serial Number: 0032820186, Firmware Version: V1.00
- ETHERNET**:
  - MAC Address: B4:37:D1:A0:0F:7F
  - Server**: Device IP Address: 192.168.1.25, Web Server Port: 80, Device Subnet Mask: 255.255.255.0
  - Client**: Remote IP Address: 192.168.1.1, Remote Port: 502
- CAN**: Baud Rate: 250 kbit/s, Auto Baud Rate Enabled: Yes, Switched Power Out: No
- DIAGNOSTICS**: CAN Frames Received: 0, CAN Frames Sent: 1, Ethernet Messages Received: 427, Ethernet Messages Sent: 131

Figure 3. Converter Home Page

The home page shows the device information, including the converter part number, serial number, and firmware version. It also shows *Ethernet* and *CAN* main configuration parameters including some communication statistics (number of messages for each interface).

You will need to allow the site to run JavaScript (this setting is default in most web browsers). If JavaScript is disabled, the website will show a message asking to activate JavaScript at the top of the web page, see

Figure 4. Enable JavaScript Prompt  
4.



Figure 4. Enable JavaScript Prompt

The *Ethernet* configuration parameters are combined into Slave (*Server*) and Master (*Client*) groups for convenience.

The *Ethernet* and *CAN* configuration parameters have tooltips clarifying their meaning, see Figure 55.

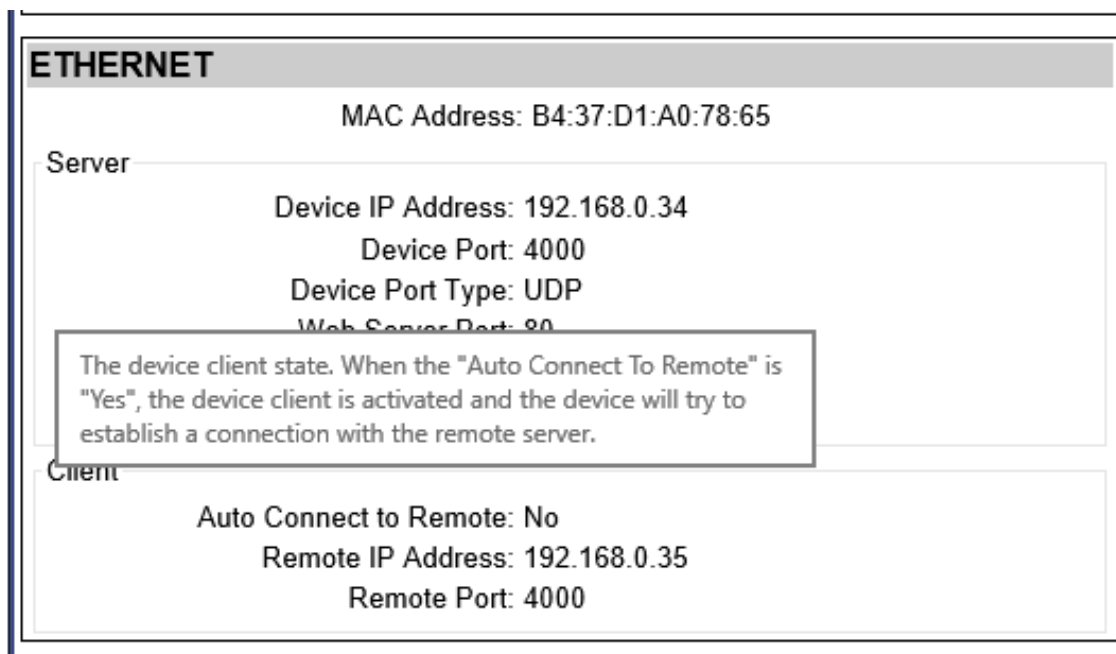

Figure 5. A Tooltip for the “Auto Connect to Remote” Configuration Parameter

## 2.1 Changing Configuration Parameters

All configuration parameters except the Modbus TCP/IP Master/Slave and CAN RX/TX settings can be changed through the *Main Settings* web page. The Modbus TCP/IP Master/Slave and CAN RX/TX configurations have their own configuration pages: For *CAN RX/TX configuration*, see Figure 6.

The configuration pages can be reached by clicking on their links on the left side of the website. Each configuration web page has fields to enter values of the configuration parameters and three buttons: “Save Settings”, “Discard Settings” and “Set Defaults”.

The “Save Settings” button will save configuration parameters to non-volatile memory and apply the new settings. The appropriate converter subsystems will be restarted without rebooting of the whole converter except for Modbus TCP/IP Master/Slave enable/disable.

The “Discard Settings” button will bring back the original converter settings before editing, and the “Set Defaults” button will load the default values of the configuration parameters into the data fields on the page.

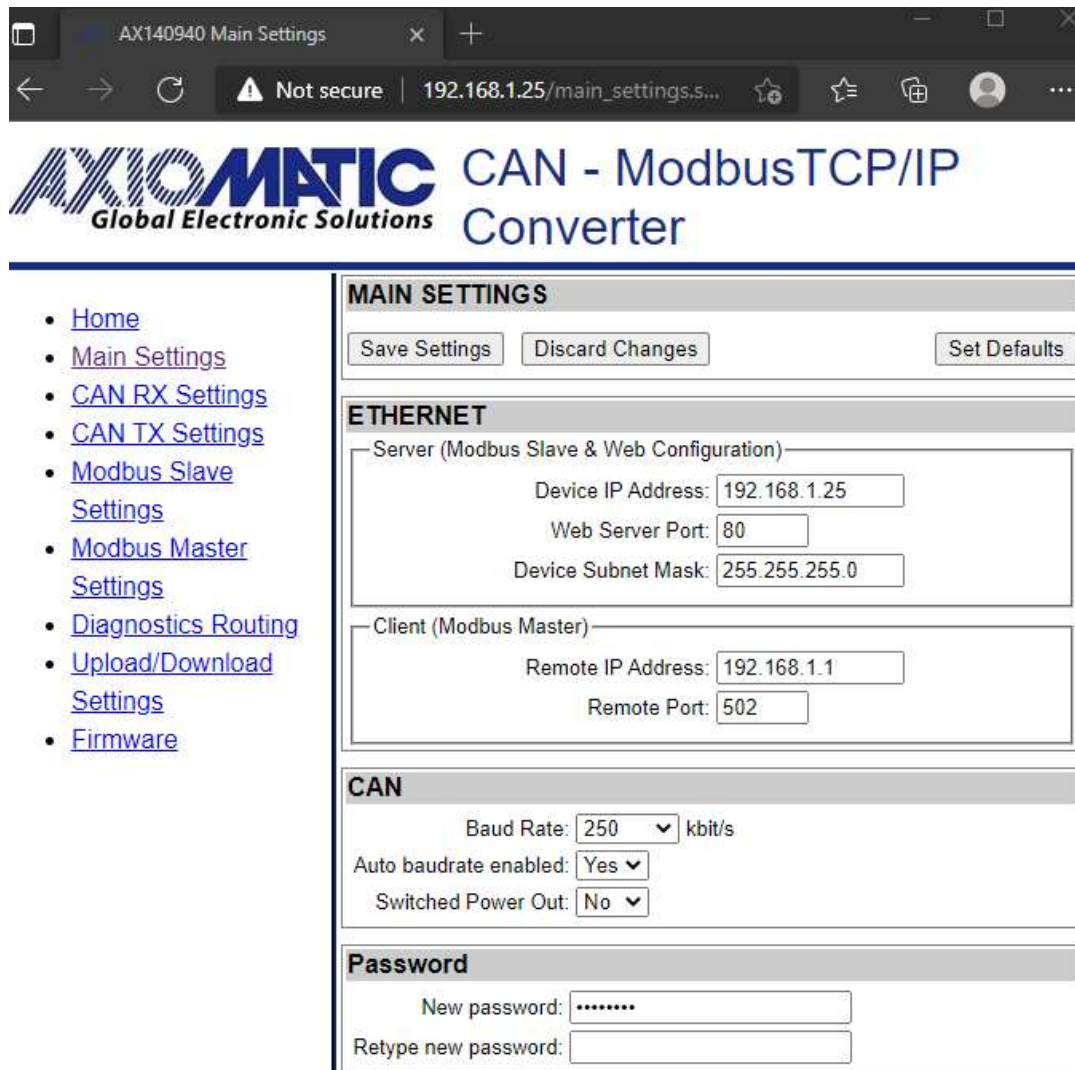

Figure 6. Converter Main Settings Page

The configuration parameters have tooltips for the user convenience. The “Remote IP Address” and “Remote Port” are set to 192.168.1.1 and 502 respectively. 502 is reserved for Modbus TCP/IP Communication. When connecting to another unit that uses same IP address, or to make a master-slave chain, do not use the same Remote IP address or same Device IP address. Needs to change the IP Address accordingly.

After pressing the “*Save Settings*” button and saving the configuration parameters, the converter replies with a confirmation message showing a result of the saving operation. For example, if the user has successfully changed the *CAN RX* settings, the following message will appear:

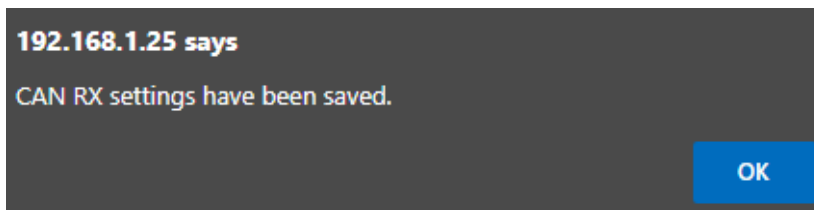

Figure 7. Settings Alert. “*Configuration Parameters*” settings have been saved.

If no configuration is changed and the last configuration is updated again without any change, the following message will appear:



Figure 8. Settings Alert. No changes to save!

The website messages should be enabled (not suppressed) in the browser to see this and other feedback messages.

In case the user leaves the page without saving, all changes will be discarded. The user can also discard changes by pressing the “*Discard Changes*” button.

## 2.2 Ethernet Configuration

All *Ethernet* configuration parameters can be changed through the “*Main Settings*” web page, except the “*MAC Address*” and “*Modbus TCP/IP Configuration*”, which is programmed at the factory. The user-changeable configuration parameters are presented in Table 2.

Table 2. Ethernet Configuration Parameters

Configuration Parameter	Default Value	Range	Description
<i>Device IP Address</i>	192.168.0.34	Any IP address	The device IP address. The embedded web server uses the same IP address.
<i>Web Server Port</i>	80	Any port value except the <i>Remote Port</i>	The communication port of the embedded web server.
<i>Remote IP Address</i>	192.168.0.35	Any IP address	The remote server IP address. Used by the device client when the <i>Auto Connect to Remote</i> is <i>YES</i> .
<i>Remote Port</i>	502	Port value – 502 Modbus TCP/IP Port	The remote server ports. Used by the device client when the <i>Modbus TCP/IP Master is Enabled</i>

## 2.3 CAN Configuration

The CAN configuration parameters can be changed through the “*Main Settings*”, “*CAN Rx Settings*”, and “*CAN Tx Settings*” web pages.

The main CAN configuration parameters are available through the “*Main Settings*” web page, see Table 3.

Table 3. Main CAN Configuration Parameters

Configuration Parameter	Default Value	Range	Description
<i>Baud Rate</i>	250 kbit/s	{1000, 666.6(6), 500, 250, 125, 100, 50, 20, 10} <sup>1</sup>	The CAN baud rate.
<i>Auto Baud Rate</i>	On	{Off, On}	Auto baud rate detect state.
<i>Switched Power Out</i>	Off	{Off, On}	State of the switch delivering power to the CAN connector.

<sup>1</sup> 666.6(6) kbit/s are set as 667.

The CAN filters have their own web pages for setting configuration parameters.

### 2.3.1 CAN Rx Configuration / *can\_rx\_settings.html*

The CAN receive message parameter settings display one message at a time. CAN Message Select section provides ‘*Next*’ and ‘*Previous*’ buttons to go to the required message. The ‘*Jump to*’ button selects the specified message directly. Settings should be saved before selecting another CAN receive message to be configured, otherwise the modified settings will be lost.

The ‘*SID: Standard ID*’ checkbox allows the device to accept the CAN messages with Standard 11-bit IDs ranging from 0x0 to 0x7FF. When SID is unchecked, the device can be configured to receive CAN messages having a specific PGN.

The ‘*Discrete*’ data type reads in the CAN data as a number (or bit field data), using the range specified by the configured number of bits (Data width). With discrete data types, the resolution, offset, minimum and maximum are not used.

The ‘*Continuous*’ data type uses the J1939 data formatting with *resolution*, *offset*, *minimum* and *maximum values*. With continuous data, the data range is limited for reserving the upper range for J1939 special and error codes.

The ‘*Data destination*’ and ‘*Data destination number*’ settings specify the target interface for the received data. The received data is always stored to a local variable assigned for each CAN receive message, but the Data destination needs to be configured for forwarding the data to the Modbus TCP/IP slave interfaces.

The *Data Destination* configured as default allows us to configure the destination of CAN messages from “*CAN TX Settings*” or “*Modbus TCP/IP Master Settings*”. CAN input data will be

directed accordingly. To make an internal CAN loop by configuring 'CAN RX message' as data destination for CAN RX.

The 'Timeout' value specifies the amount of time for which CAN data will be stored in the input buffer after receiving the data. Setting 'Timeout' to 0 will allow us to use the last CAN input data continuously until we receive a new message. Setting 'Timeout' to any other value will expire the current CAN input buffer after the configured timeout.

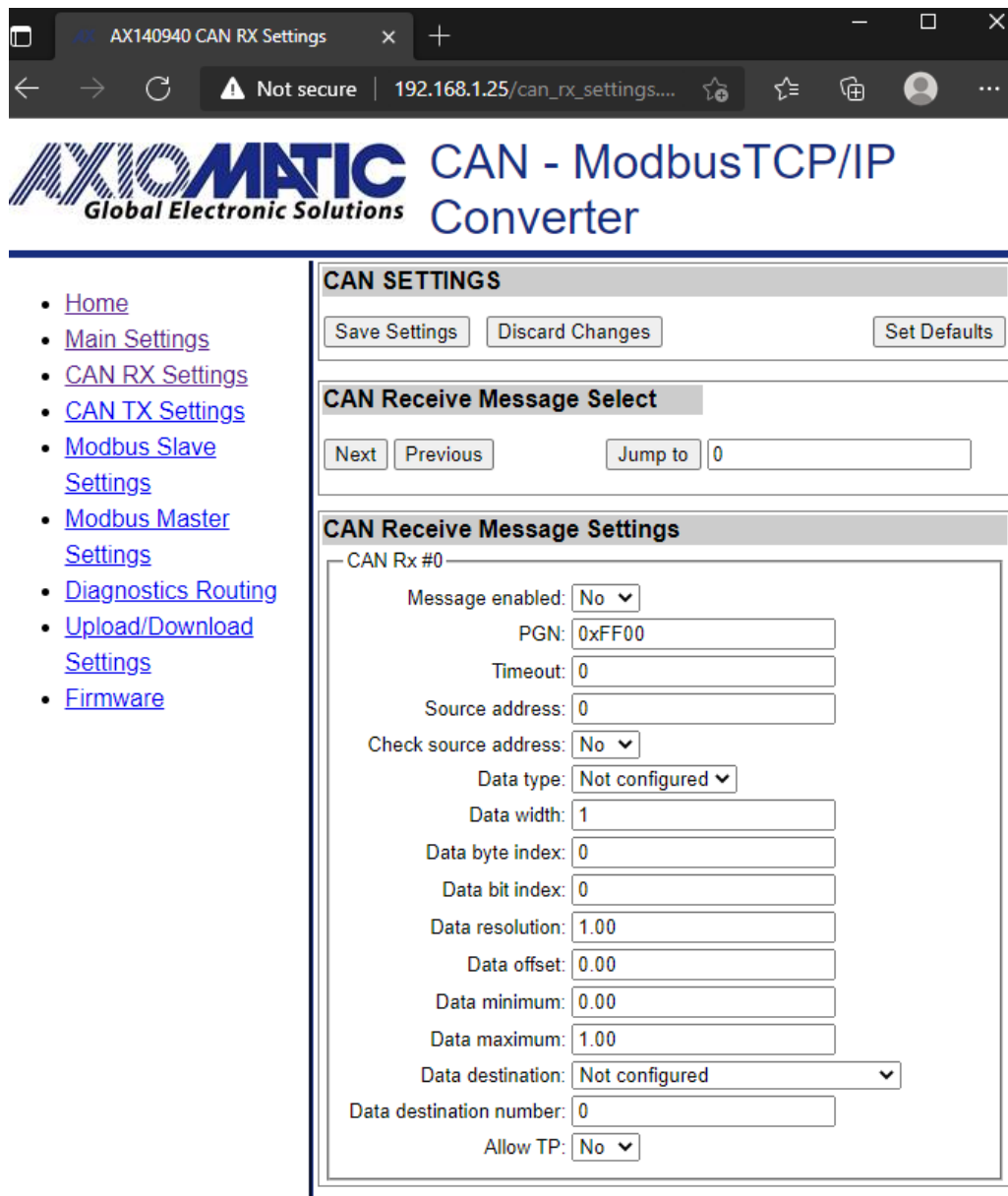

Figure 9. Converter CAN Rx Default Configuration Page

The 'Data Maximum' specifies the maximum value received on CAN input. i.e., setting 'Data Maximum' to 65535, specify any value more than 0xFFFF will be filtered out.

If 'Check Source Address' is disabled, all input CAN messages from the same PGN will be output on the 'Data Destination'.

The user can independently configure ‘CAN RX Message’ Settings for each CAN Message, through ‘CAN Receive Message Select’ – ‘Next’, ‘Previous’ or ‘Jump to’.

“CAN RX Settings” for each message run in parallel. It is sufficient to satisfy requirements of any active filter to pass the CAN message to the Ethernet network.

If ‘Message Enabled’ is set to NO, it is considered that the CAN Rx settings for that message are disabled, and do not participate in the message filtering process.

### **2.3.2 CAN Tx Configuration / can\_tx\_settings.html**

Each of the 16 CAN transmit messages support up to 16 signals for sending out received data. The transmit messages support the same ‘Discrete’ and ‘Continuous’ data types with same characteristics than CAN receive messages do.

Settings should be saved before selecting a new transmit message or transmit signal. In case the values are not saved, the modifications are lost when a new message or signal is selected.

The ‘TX interval’ specifies time difference between two successive received CAN frames in milliseconds.

The ‘Allow TP’ configured as YES, allows converter to receive more than 4 bytes continuously. This is useful in the event when more than 2 Modbus registers need to be read at a time.

There are independent “CAN TX Settings” configuration for each CAN message.

Once the message is activated by checking the YES/NO box, the CAN messages will be available from configured data source. Source can be Modbus TCP/IP registers, Modbus TCP/IP master or CAN\_RX, depending on TX Interval. If TX interval is set to zero, CAN port will never receive any data from the source, as TX Interval should be more than zero except direct CAN message is used.

Transmit Messages configured with the same PGNs will be combined as a single message if they have a similar ‘TX Interval’. If the shared messages have overlap in Byte or bit indexing, then the indexing configured in the higher CAN transmit message will be used. For example, if CAN transmit messages second and third have the same PGNs and overlapping in the 5<sup>th</sup> Byte, then the 5<sup>th</sup> Byte will contain the data of the third transmit message.

Direct CAN message from Modbus TCP/IP Master can be received as CAN frames even if TX Interval is set to zero, as Direct CAN Message from Modbus Master will not consider “CAN TX settings”.

All “CAN Message settings” run in parallel. It is sufficient to satisfy requirements of any active message to send the CAN message to the Ethernet network.

If ‘Message Enabled’ is set to NO, it is considered that the CAN Tx settings for that message are disabled, and do not participate in the message filtering process.

# AXOMATIC Global Electronic Solutions CAN - ModbusTCP/IP Converter

- [Home](#)
- [Main Settings](#)
- [CAN RX Settings](#)
- [CAN TX Settings](#)
- [Modbus Slave Settings](#)
- [Modbus Master Settings](#)
- [Diagnostics Routing](#)
- [Upload/Download Settings](#)
- [Firmware](#)

**CAN SETTINGS**

**CAN Transmit Message Select**

**CAN Transmit Message Settings**  
CAN Tx #0  
Message enabled:    
PGN:   
TX interval:   
Priority:   
Destination address:

**CAN Transmit Signal Select**

**CAN Transmit Signal Settings**  
CAN Tx #0 Signal #0  
Signal data source:    
Signal data number:   
Signal data type:    
Signal data width:   
Signal data byte index:   
Signal data bit index:   
Signal data resolution:   
Signal data offset:   
Signal data minimum:   
Signal data maximum:

Figure 10. Converter CAN ID Mask Filters Page

### 3 Modbus TCP/IP Settings

The CAN to Modbus TCP/IP Converter supports Modbus TCP/IP slaves running on Ethernet port. The number and start address for each of the Modbus TCP/IP slave's inputs, coils and registers can be specified, see Figure 11.

Please note that the slave interface is enabled only if the Modbus TCP/IP master implementation is not running on that interface.

The number of inputs, coils and registers have an upper limit, and the web server will not accept values beyond the built-in maximum limit.

The screenshot shows a web browser window with the following details:

- Browser tab: AX140940 Modbus Slave Setting
- Address bar: 192.168.1.25/modbus\_settings.sh...
- Page Title: CAN - ModbusTCP/IP Converter
- Logo: AXOMATIC Global Electronic Solutions
- Navigation menu (left):
  - Home
  - Main Settings
  - CAN RX Settings
  - CAN TX Settings
  - Modbus Slave Settings
  - Modbus Master Settings
  - Diagnostics Routing
  - Upload/Download Settings
  - Firmware
- Main Content Area: MODBUS SLAVE SETTINGS
  - Buttons: Save Settings, Discard Changes, Set Defaults
  - Section: TCP/IP
    - Settings
      - Modbus TCP Port: 502
      - Number of coils: 10
      - Coils start address: 1
      - Number of inputs: 10
      - Inputs start address: 1
      - Number of input registers: 10
      - Input registers start address: 1
      - Number of holding registers: 256
      - Holding registers start address: 1

Figure 11. Converter Slave Settings

### 3.1 Modbus TCP/IP Master Settings

The CAN to Modbus TCP/IP Converter supports Modbus TCP/IP master running on its Ethernet port. The 'Ethernet Master Enable' options need to be set to YES for enabling the Modbus TCP/IP master, see Figure 12.

Please note that enabling the Modbus TCP/IP master will disable the Modbus TCP/IP slave for that device. As at a time one device can either work as Master or as Slave.

The Default target and Default source data routing options are the built-in variables for each Modbus TCP/IP master message definition. The CAN receive message data target configuration can access these variables directly if configured to do so on the CAN receive message configuration page.

The received Modbus TCP/IP data can be also sent directly to CAN bus by selecting the 'Direct CAN TX' option for the Forward received data to setpoint. In this case, the Received data number specifies the J1939 PGN to use (the priority will default to 6 and the CAN to Modbus TCP/IP Converter's J1939 address will be used as the source address for the direct transmit messages).

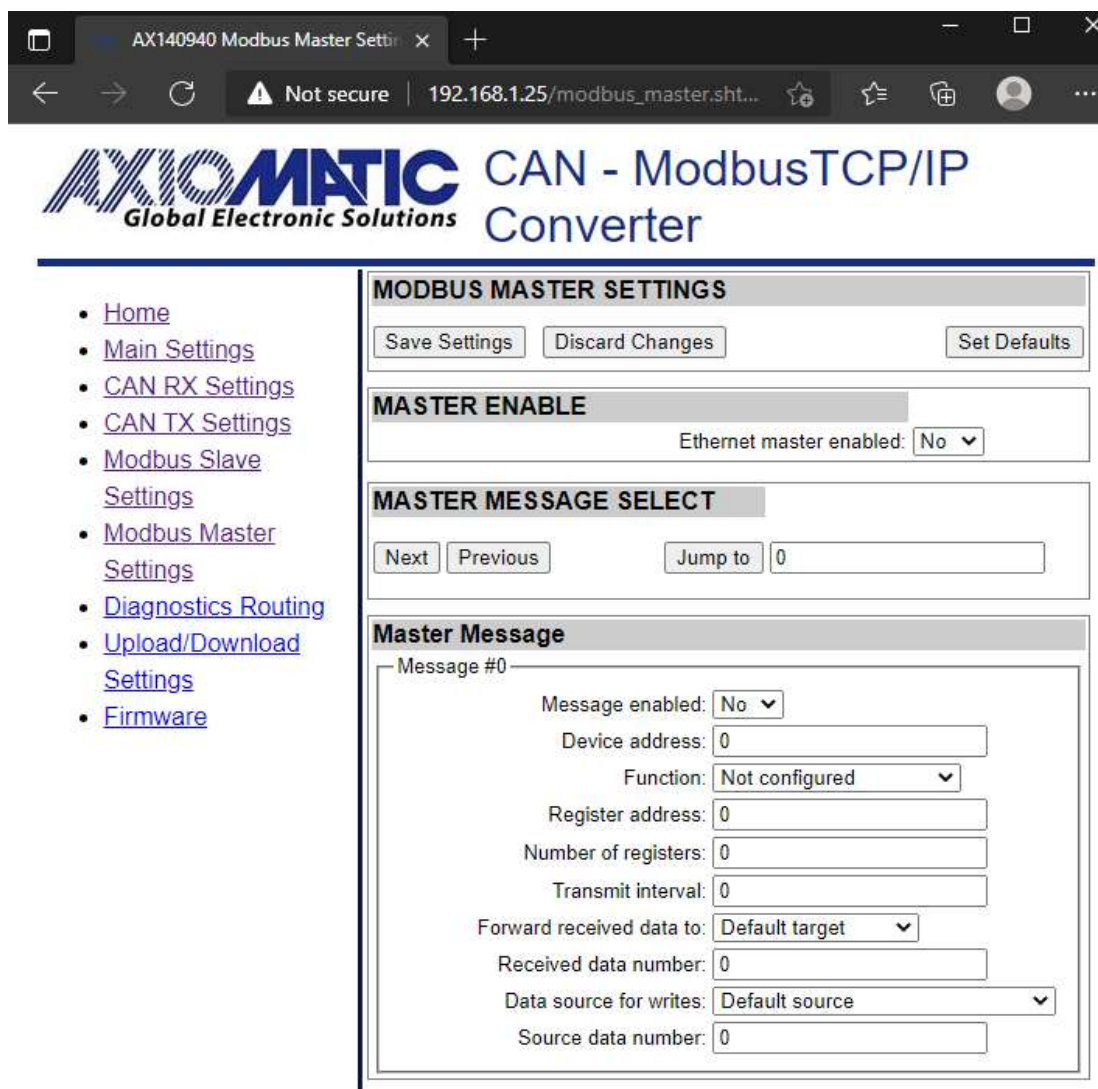

The screenshot shows a web browser window with the URL `192.168.1.25/modbus_master.sht...`. The page title is "AXIOMATIC CAN - Modbus TCP/IP Converter". The logo for AXIOMATIC Global Electronic Solutions is visible. The main content area is titled "MODBUS MASTER SETTINGS" and contains several sections:

- MODBUS MASTER SETTINGS**: Includes buttons for "Save Settings", "Discard Changes", and "Set Defaults".
- MASTER ENABLE**: A section with a dropdown menu for "Ethernet master enabled:" set to "No".
- MASTER MESSAGE SELECT**: A section with "Next" and "Previous" buttons, and a "Jump to" field with the value "0".
- Master Message**: A section for configuring "Message #0" with the following fields:
  - Message enabled: No (dropdown)
  - Device address: 0 (text input)
  - Function: Not configured (dropdown)
  - Register address: 0 (text input)
  - Number of registers: 0 (text input)
  - Transmit interval: 0 (text input)
  - Forward received data to: Default target (dropdown)
  - Received data number: 0 (text input)
  - Data source for writes: Default source (dropdown)
  - Source data number: 0 (text input)

A left-hand navigation menu contains the following links: Home, Main Settings, CAN RX Settings, CAN TX Settings, Modbus Slave Settings, Modbus Master Settings, Diagnostics Routing, Upload/Download Settings, and Firmware.

Figure 12. Modbus TCP/IP Master Settings

### 3.2 Diagnostics Routing

J1939 DM1 configurable diagnostics frames can be routed to Modbus TCP/IP slave interfaces using the Diagnostics routing configuration. There are 16 configurable diagnostics messages.

The routing options include routing all received diagnostics to Modbus TCP/IP or only routing the specified ones. It can be configured through *Diagnostics routing enabled*, which has three options in the drop list, 'No diagnostics routing', 'Route specified SPN/FMI/SA' and 'Route all'.

In case specified diagnostics routing is configured, the SPN (Suspect Parameter Number (from SAE J1939 standard)) is the most important parameter to configure. The diagnostics are filtered mainly using the SPN. In case needed, the FMI and SA values can be used for more detailed filtering of the received DM1 frames. The FMI and SA can be set to "don't care" values (32 for FMI and 255 for SA) for accepting a wider range of SPNs.

SPN and FMI are sent by the source on a diagnostic message. The ECU is compliant with the standard SAE J1939. It is user's responsibility to select SPN that will not violate J1939 standard. For Diagnostics, DM1 – Active Diagnostic Trouble Codes supports PGN 65227 (0x00FECB).

The received DM1 data is forwarded to Modbus TCP/IP slave holding registers using the following data layout.

	Holding register	
	<15:8>	<7:0>
<MB diag. start addr.>		SPN (MSBs)
<MB diag. start addr. + 1>	SPN (16 LSBs)	
<MB diag. start addr. + 2>	Lamp	FMI
<MB diag. start addr. + 3>	SA	OC

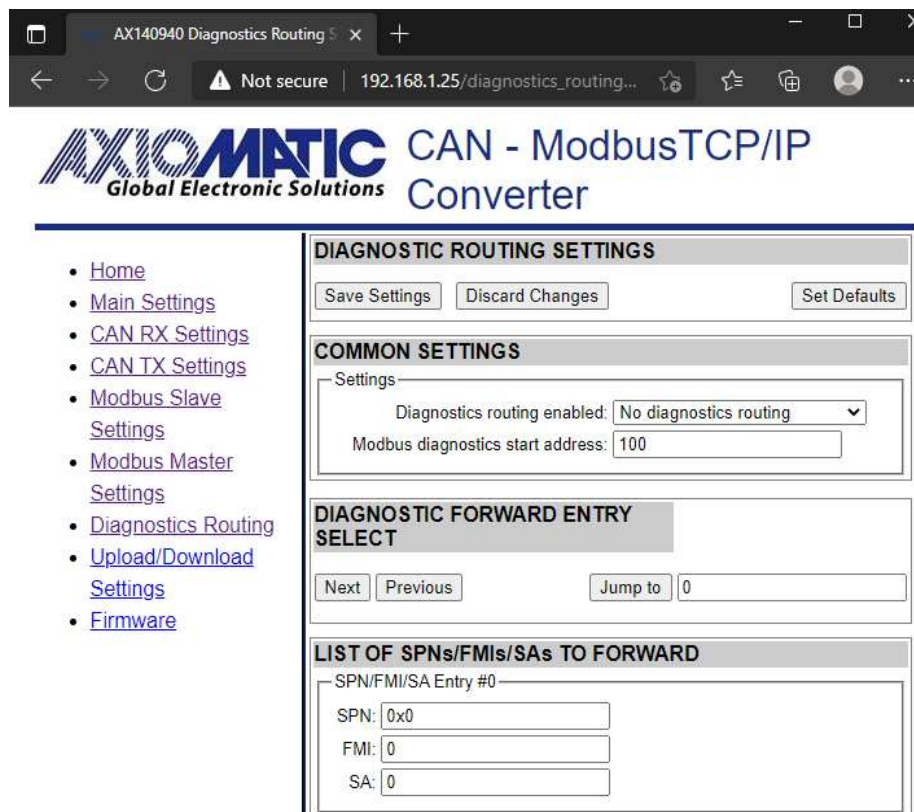

Figure 13. Health Status Message on CAN Error

### 3.3 Upload/Download Settings

The settings can be downloaded from the CAN to Modbus TCP/IP Converter as a binary file. When a settings file is uploaded to the CAN to Modbus TCP/IP Converter, the settings are checked using a CRC32 checksum. In case the checksum is not correct, the uploaded settings will not be stored to non-volatile memory.

The firmware v1.x requires a power cycle for applying the uploaded settings.

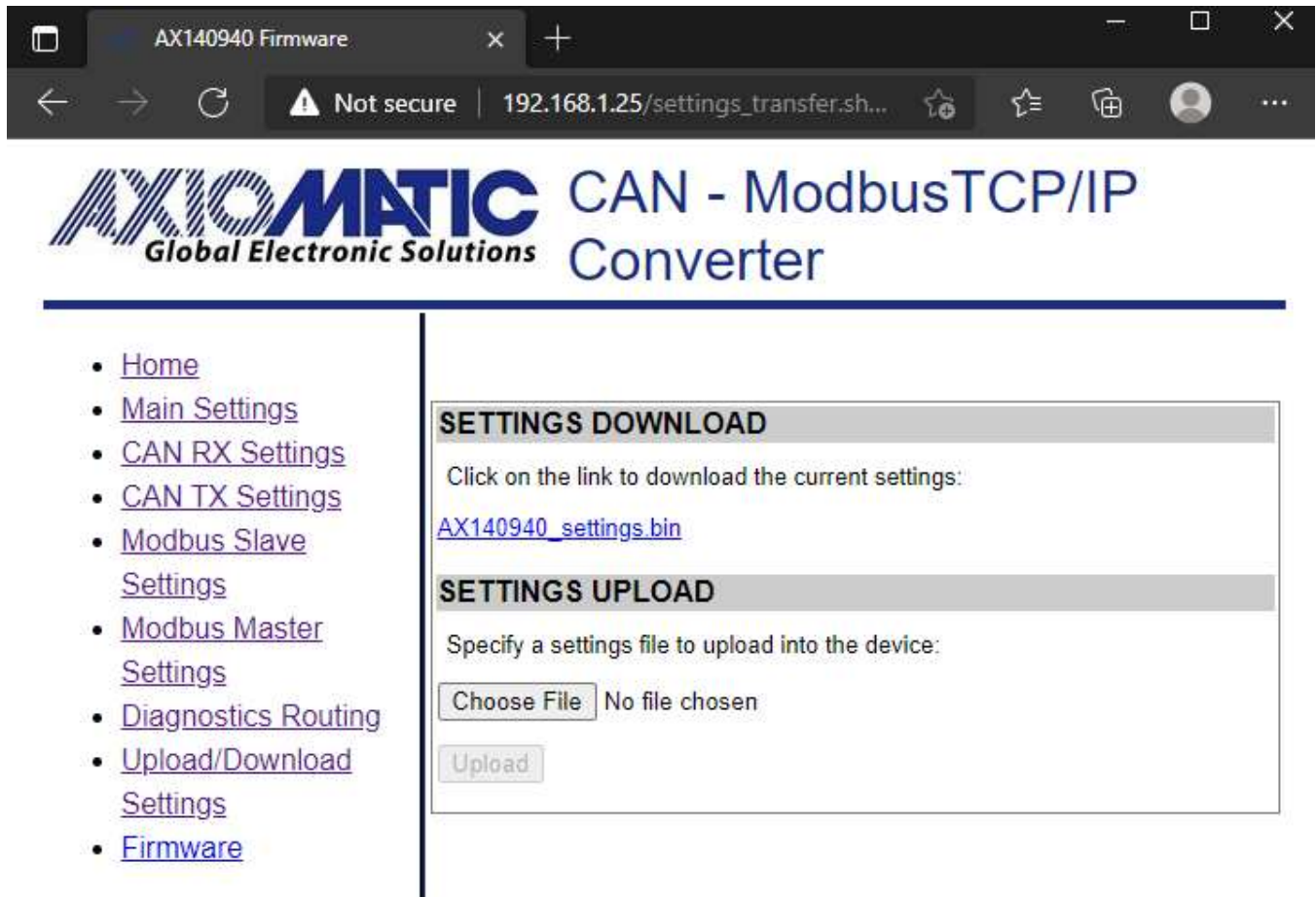

Figure 14. Health Status Message on CAN Error

## 4 FIRMWARE UPDATE

The converter firmware can be updated through the website.

The firmware update procedure is performed in two stages:

First, the application firmware is uploaded into the converter internal flash. During this stage, the converter checks the firmware checksum and whether it can be programmed into the unit.

Second, upon the user confirmation, the firmware is programmed into the microcontroller and the unit is restarted. At the end of this process, the user should see the new firmware version number on the converter home page in the browser.

The details of the firmware update are provided below.

### 4.1 Uploading the New Firmware

To upload the new firmware, the user should activate the *Firmware Uploading* page, Figure 155, by clicking on the “*Firmware*” link on the left side of the web page.

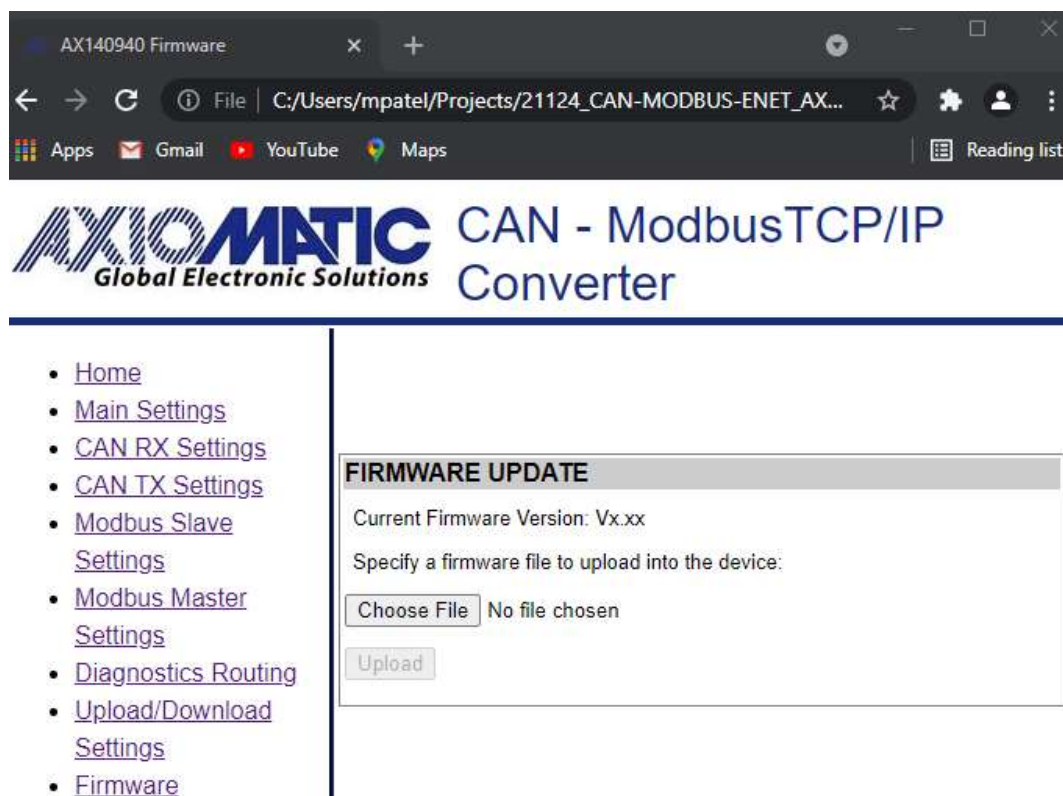

Figure 15. Firmware Uploading Page

Then the user selects the new firmware file using the *Browse...* button.

The firmware file is provided by Axiomatic in a proprietary binary format with extension: *.af*. The file name should have the following format: *AF-21124-X.XX.af*, where the *<X.XX>* field wildcard reflects the firmware version number. We will use *AF-21124-1.00.af* file for illustration of the firmware update process in this manual.

When the file is selected, the user should press the *Upload* button. The user will see the dynamic message: “Loading...” in the bottom of the screen and then, if everything is in order, the converter will switch automatically to the “*Firmware Update*” page.

## 4.2 Applying the New Firmware

On the *Firmware Update* page, the user will see the new firmware file information.

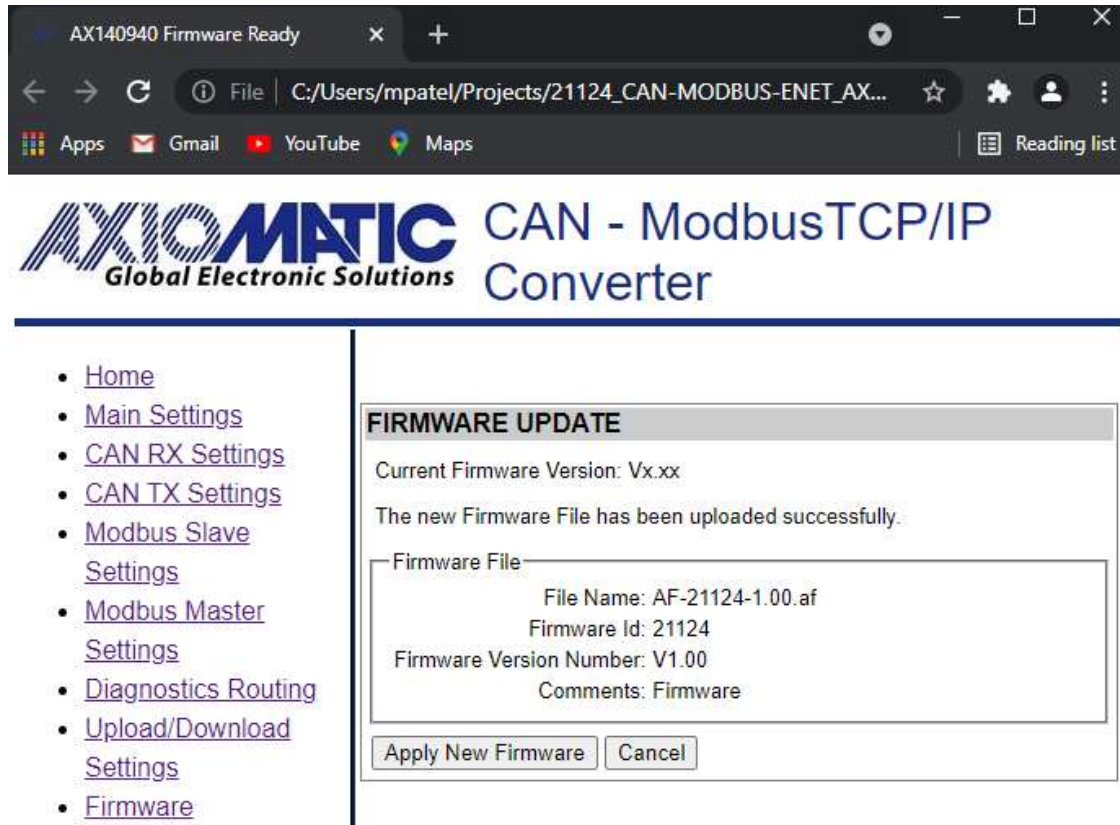

Figure 16. Firmware Update Page

From this point, the user can cancel the firmware update process and keep the old firmware or proceed with flashing the new firmware into the microcontroller by pressing the ‘*Apply New Firmware*’ button.

When the user presses the ‘*Apply New Firmware*’ button, the firmware update process is activated, and the ‘*Firmware Upload*’ page will show the countdown timer.

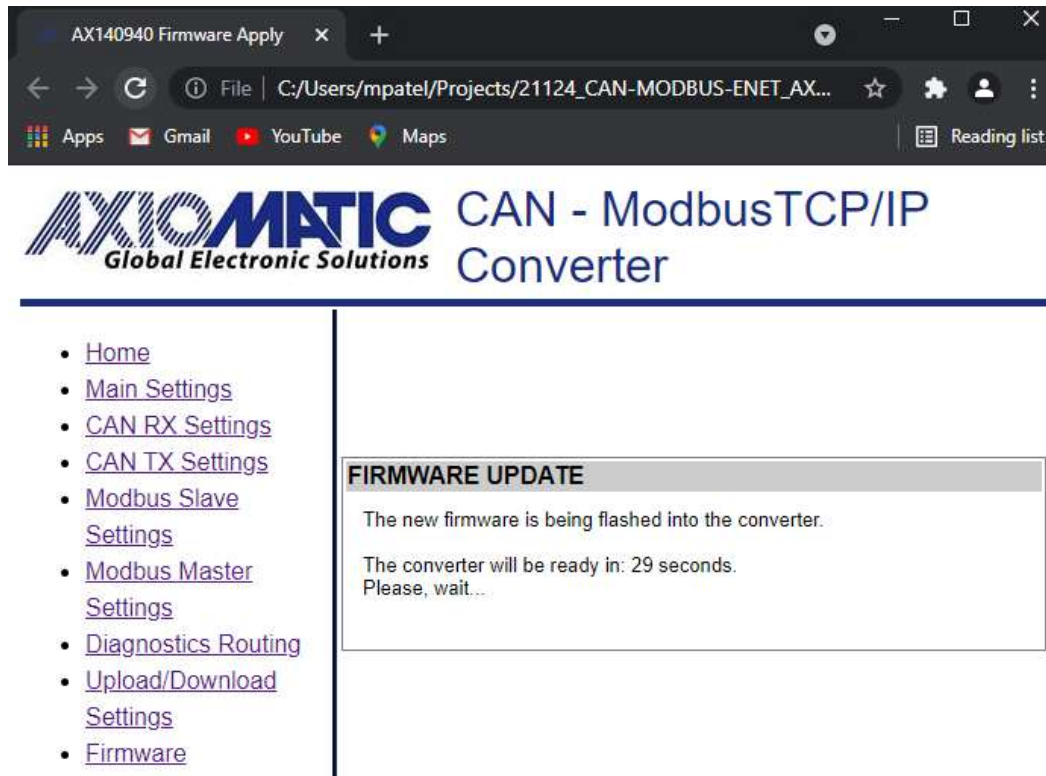

Figure 17. Firmware Update Countdown has been Started.

The countdown timer is set for 30 seconds necessary to complete the flashing process and reboot the unit, after which the converter home page will be displayed. The user will see the new application firmware version number in the *Device Information* section on the converter home page.

## 5 CONVERTER DEPLOYMENT

There are two major approaches in using the CAN to Modbus TCP/IP Converter. One is to use the converter on its own as a CAN extender or a baud rate converter.

For example, a pair of coupled converters can synchronize two CAN networks. This example can be extended to several CAN networks running at different baud rate in various remote locations, connected using the CAN to Modbus TCP/IP Converter.

The majority of Axiomatic PC software tools support the Ethernet to CAN converter. They can connect to the CAN bus using the Ethernet to CAN converter the same way as they connect to the bus using the USB to CAN converter. The Axiomatic Electronic Assistant® (EA) can communicate with the converter starting from version 5.11.82.0, and the CAN Assistant – Scope and CAN Assistant – Visual support the converter starting from version 3.0.0.

The use of the Ethernet to CAN converters for synchronizing CAN networks with or without baud rate conversion is described below. There is no need for custom software for this type of the converter deployment.

### 5.1 CAN Network Synchronization

To synchronize two remote CAN networks, the user can simply connect an Ethernet to CAN converter to each of the CAN network and configure the converters the way that they will talk with each other.

#### 5.1.1 Hardware Setup

The converters should be connected through a local or global IP network, see: Figure 18 and Figure 19.

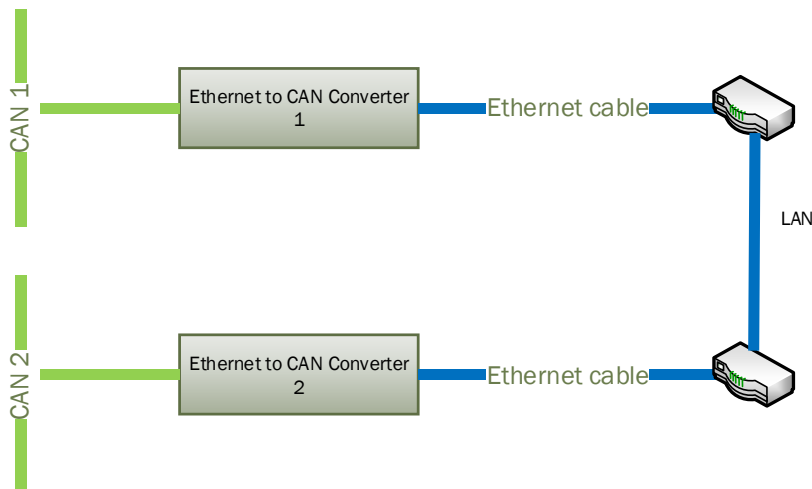

Figure 18. Local Connection through the LAN

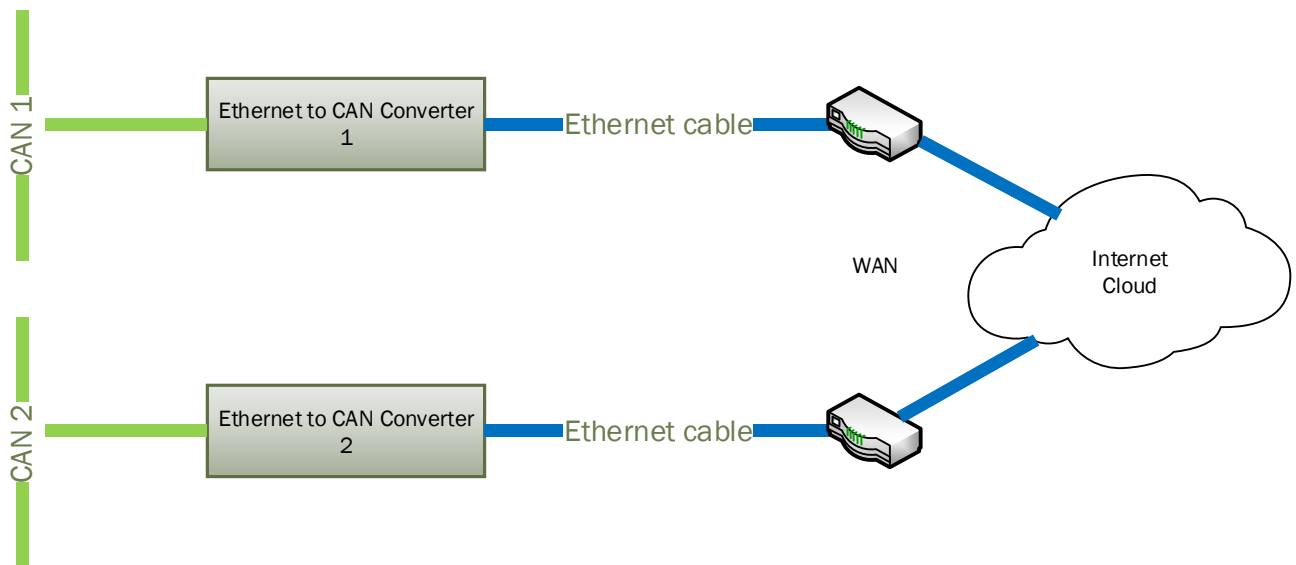

Figure 19. Global Internet Connection through the WAN

In the simplest scenario, two pre-configured converters can be connected by an Ethernet cable, see: Figure 20. Due to the Auto-MDIX feature, both: the straight and crossover cables can be used.

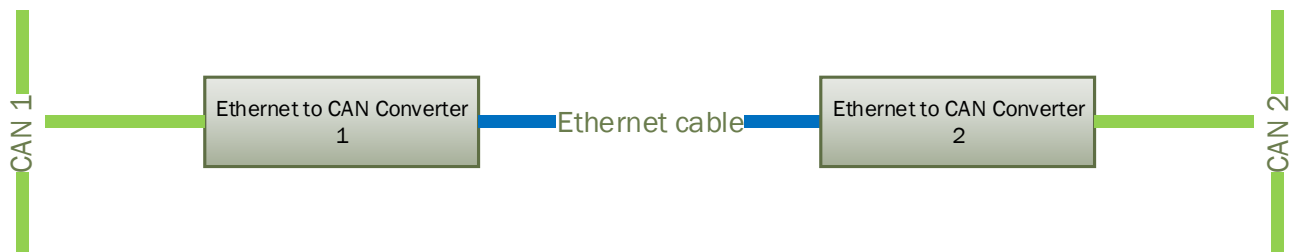

Figure 20. Simple Local Connection

The user can synchronize more than two CAN networks on LAN or WAN. There are practically no limits on the number of synchronized CAN networks, see daisy-chain connection in the [Client Configuration](#) section in Figure 23.

## 5.1.2 Converter Configuration

After the physical connection is established, the converters should be configured to exchange messages between each other. Since the converters support client/server communication model, one of the converters should be a server and the other one – a client.

### 5.1.2.1 Server Configuration

To configure the converter as a server (slave), first set: *'Device IP Address'* to the appropriate values received from your network administrator.

Set *'Modbus TCP/IP Master Enable'* to *No* to disable the client (master) side of the converter. Set the *Remote IP Address* to the appropriate value other than 192.168.1.1, as for client-server configuration, this will work as default gateway.

*'Remote Port'* can be left untouched since they are not used by the converter when the client mode is disabled. They are grayed on the *'Settings page'* in this mode.

For the CAN network, configure the necessary 'Baud Rate' and Set 'Auto baud rate enable' to YES.

An example of the converter configuration as a server is presented in Figure 21.

The screenshot shows a web browser window with two tabs for 'AX140940 Main Settings'. The address bar shows '192.168.1.25/main\_settings...'. The page title is 'AXOMATIC Global Electronic Solutions CAN - ModbusTCP/IP Converter'. On the left is a navigation menu with links: Home, Main Settings, CAN RX Settings, CAN TX Settings, Modbus Slave Settings, Modbus Master Settings, Diagnostics Routing Settings, Upload/Download Settings, and Firmware. The main content area is titled 'MAIN SETTINGS' and contains three sections: 'ETHERNET', 'CAN', and 'Password'. The 'ETHERNET' section has two sub-sections: 'Server (Modbus Slave & Web Configuration)' and 'Client (Modbus Master)'. The 'Server' section has fields for 'Device IP Address' (192.168.1.25), 'Web Server Port' (80), and 'Device Subnet Mask' (255.255.255.0). The 'Client' section has fields for 'Remote IP Address' (192.168.1.24) and 'Remote Port' (502). The 'CAN' section has fields for 'Baud Rate' (250 kbit/s), 'Auto baudrate enabled' (Yes), and 'Switched Power Out' (No). The 'Password' section has fields for 'New password' and 'Retype new password'.

Figure 21. The Converter Server Configuration Example

### 5.1.2.2 Client Configuration

In the client configuration, the user should set 'Device IP Address' the same way as with the server configuration. Remote IP Address and Remote Port to match the settings of the converter

in the server mode and activate the client mode by setting the 'Modbus TCP/IP Master Enable' to YES.

The CAN network setup is done similarly to the server mode; the 'Baud Rate' is set to the desired baud rate (not necessarily the same as on the server).

An example of the converter configuration in a client mode is presented in Figure 22.

The screenshot shows a web browser window with two tabs labeled 'AX140940 Main Settings'. The address bar shows '192.168.1.24/main\_settings...'. The page title is 'AXIOMATIC Global Electronic Solutions CAN - ModbusTCP/IP Converter'. On the left is a navigation menu with links: Home, Main Settings, CAN RX Settings, CAN TX Settings, Modbus Slave Settings, Modbus Master Settings, Diagnostics Routing Settings, Upload/Download Settings, and Firmware. The main content area is titled 'MAIN SETTINGS' and includes buttons for 'Save Settings', 'Discard Changes', and 'Set Defaults'. It is divided into three sections: 'ETHERNET', 'CAN', and 'Password'. The 'ETHERNET' section has two sub-sections: 'Server (Modbus Slave & Web Configuration)' and 'Client (Modbus Master)'. The 'Server' section contains fields for 'Device IP Address' (192.168.1.24), 'Web Server Port' (80), and 'Device Subnet Mask' (255.255.255.0). The 'Client' section contains fields for 'Remote IP Address' (192.168.1.1) and 'Remote Port' (502). The 'CAN' section contains a 'Baud Rate' dropdown set to 250 kbit/s, 'Auto baudrate enabled' set to Yes, and 'Switched Power Out' set to Yes. The 'Password' section contains fields for 'New password' and 'Retype new password'.

Figure 22. The Converter Client Configuration Example

The values of the *Device Port Type*, *Remote IP Address* and *Remote Port* of the client on Figure 22 are the same as the *Device Port Type*, *Device IP Address* and *Device Port* of the server in Figure 23.

Please note, that if the converters are connected over the internet, the '*Remote IP Address*' of the client will be a public IP address of the server, not the internal server IP address presented as the '*Device IP Address*' on Figure 21. The network administrator on the server side will be required to configure port forwarding to open internet access to the converter in the server mode.

When the converter is configured as a client, it will still act as a server accepting connections on the *Device Port* from other clients. This adds versatility to the converter configurations since the same converter can be used together with both: client and server communication nodes. As an example, the user can establish an unlimited number of daisy-chain client-server connections, see: Figure 23.

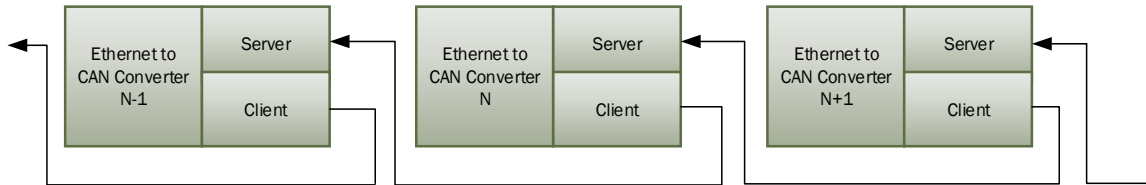

Figure 23. Daisy-Chain Converter Connection

## 6 TECHNICAL SPECIFICATIONS

### 6.1 Power Supply

#### 6.1.1 Input

Power supply input is located on the Ethernet connector. The power supply uses automotive battery power. It is not compatible with the PoE (Power over Ethernet) IEEE 802.3 standard.

Table 4. Power Supply Input

Parameter	Value	Remarks
Supply Voltage	9...36 VDC	12V, 24V – nominal
Power Consumption	2W	Maximum at 12V
Protection	Under Voltage Shutdown Over Voltage Shutdown Reverse Polarity Transients	< 6 V > 37V  12V Load Dump

#### 6.1.2 Output

Power supply output is located on the CAN connector.

Table 5. Power Supply Output

Parameter	Value	Remarks
Voltage Output	9...36 VDC	Pass-through power from the power supply input.
Current Output	0.7A	Maximum pass-through current.
Voltage Drop	1V	Maximum
Protection	Overcurrent Short to Battery Short to Ground	> 1A

### 6.2 Ethernet

Table 6. Ethernet Parameters

Parameter	Value	Remarks
Number of Ports	1	
Port Type	10BASE-T, 100BASE-TX	Auto-configuration and full-duplex supported.
MDIX	Auto-MDIX	Auto-crossover to eliminate cabling mismatch.
LED Indicators	Speed/Activity	
Protocols	Ethernet IEEE 802.3, IP, ICMP, ARP, UDP, TCP, HTTP	The internal web server uses HTTP protocol.
Modbus Slave Mode	Up to 32 bi-directional simultaneous connections	Only if the <i>Modbus Master Mode</i> is Enabled
Modbus Master Mode	1 remote bi-directional connection	Auto-connect to a remote server if connection is dropped or temporary unavailable. Client mode can be disabled.
Web server	Provided	Always enabled for converter configuration and diagnostics.
Internal Diagnostics	Health Status	Internal health status of the converter is transmitted in heartbeat messages. It is also available from the web server.

## 6.2.1 Ethernet Connector

M12 socket, 8-pin, A-coded, female connector, Phoenix Contact, P/N: 1441817.

Table 7. Ethernet Connector Pinout

PIN #	Description
1	BAT + (9-36V)
2	BAT – (GND)
3	BAT – (GND)
4	ETH_TX –
5	ETH_RX +
6	ETH_TX +
7	BAT + (9-36V)
8	ETH_RX –

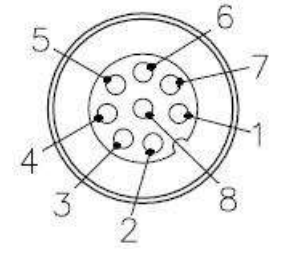

Use A-coded mating connectors compliant with IEC 61076-2-101:2012.

The AX070531 Ethernet and Power Cable - 1.7m (5.5 ft.), 8-pin M12 A-coded, Unterminated Leads, Ethernet Jack, can be used for experimenting. The cable is rated -40...+75 °C.

## 6.3 CAN

Table 8. CAN Parameters

Parameter	Value	Remarks
Number of Ports	1	
Port Type	High Speed, ISO 11898-2 compatible	Twisted pair, up to 1 Mbit/s. Shield connection is provided if shielded cable is used.
Baud Rate	1000, 666.6(6), 500, 250, 125, 100, 83.3(3), 50, 20, 10 <sup>1</sup>	[kbit/s]. Programmable through web interface.
Protocol	CAN Bosch 2.0A and B	Data Frames and Remote Frames with Standard and Extended IDs are supported. CAN ID range and mask filtering is provided.

CAN port does not contain 120 Ohm termination resistor.

### 6.3.1 CAN Connector

M12 socket, 5-pin, A-coded, female connector, Phoenix Contact, P/N: 1441778.

PIN #	Description
1	CAN_SHIELD
2	POUT + (Switch Output)
3	POUT – (GND)
4	CAN_H
5	CAN_L

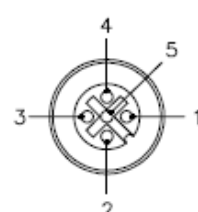

Use mating A-coded connectors compliant with IEC 61076-2-101:2012.

The AX070532 CAN Cable - 1.5 m (5 ft.), 5-pin M12 A-coded, Unterminated Leads, can be used for experimenting. The cable is rated -40...+105 °C.

## 6.4 General Specifications

Table 9. General Specifications

Parameter	Value	Remarks
Operating Temperature	-40...+85 °C	Industrial temperature range
Storage Temperature	-40...+85 °C	
Environmental Protection	IP67	IEC 60529
Vibration	Sine sweep, 5-200 Hz, 8.9G peak, 2.5 hr (15 sweeps), each axis. Random, 10-1014 Hz, 6.86 Grms, 5.0 hr, each axis.	Custom profile
Shock	50G peak, 5 shocks, each axis	Custom profile
Size	4.19in x1.82in x1.32in (107mm x 47mm x 34 mm)	See dimensional drawing
Weight	0.15 lb (0.068 kg)	
Compliance	RoHS Directive	

Table 10. Electromagnetic Compatibility (EMC)

Standard	Description
EN 13309: 2010	Construction Machinery- Electromagnetic Compatibility of Machines with Internal Electrical Power Supply.
EN61000-6-4:2005	Emission Standard for Industrial Environments
EN61000-6-2:2007	Generic Standards – Immunity for Industrial Environments

## 6.5 Accessories

Table 11. Accessories

Axiomatic P/N	Description
AX070531	AX070531 Ethernet and Power Cable - 1.7m (5.5 ft.), 8-pin M12 A-coded, Unterminated Leads, Ethernet Jack.
AX070532	CAN Cable - 1.5 m (5 ft.), 5-pin M12 A-coded, Unterminated Leads.
AX140940K	Service tool kit, contains: <ul style="list-style-type: none"> <li>AX140940 CAN to Modbus TCP/IP Converter:</li> <li>AX070531 Ethernet and Power Cable - 1.7m (5.5 ft.), 8-pin M12 A-coded, Unterminated Leads, Ethernet Jack;</li> <li>AX070532 CAN Cable - 1.5 m (5 ft.), 5-pin M12 A-coded, Unterminated Leads.</li> </ul>

## 6.6 Housing

Injection molded enclosure and cover. Material: PA66, 30% glass fiber reinforced, flame retardant UL 94 V-0. Ultrasonically welded. For dimensional drawing, see Figure 24.

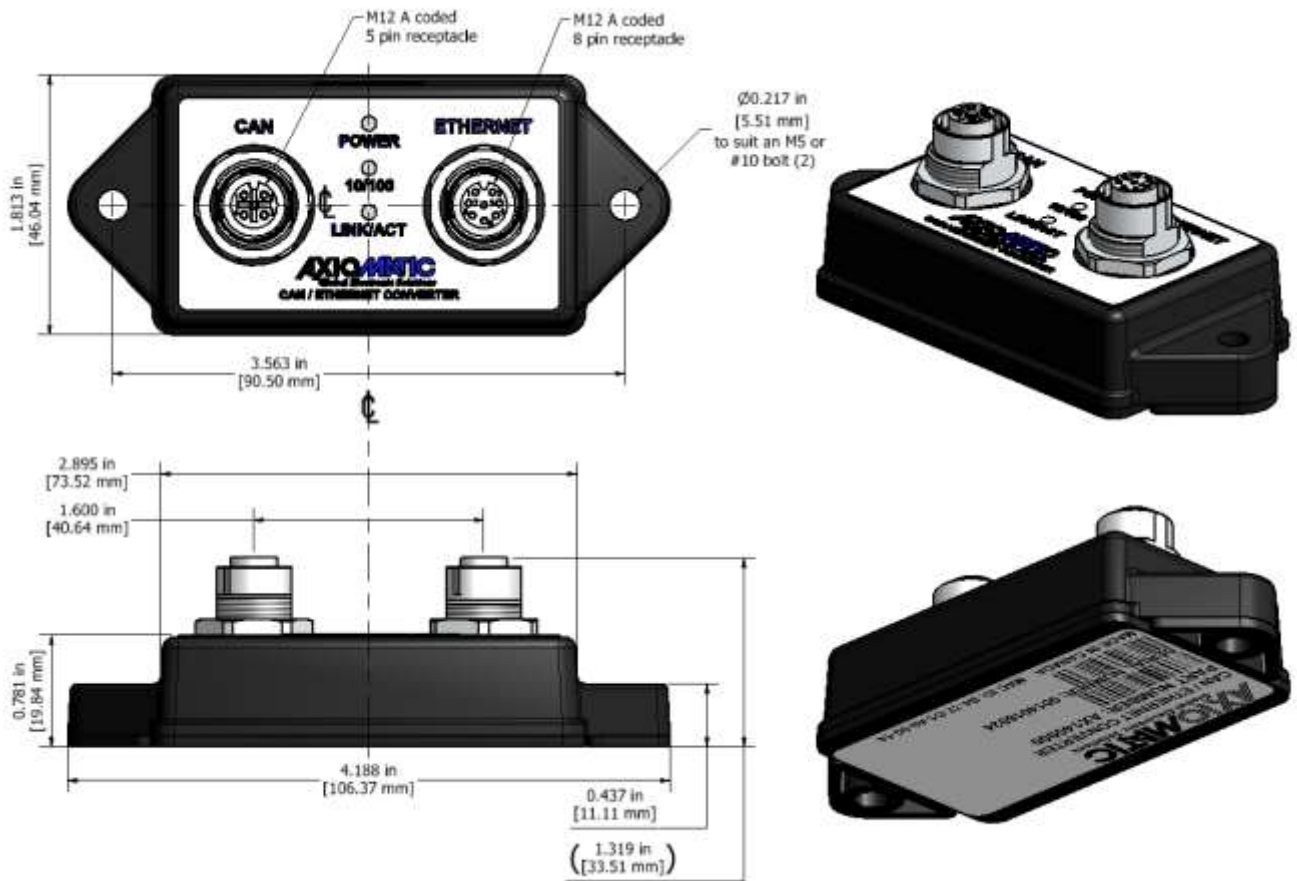

Figure 24. Dimensional Drawing

## 7 THIRD PARTY SOFTWARE LICENSE NOTICES

This section contains Third Party Software License Notices and/or Additional Terms and Conditions for licensed third-party software components included in the Ethernet to CAN Converter firmware.

Table 12. Third Party Software License Notices

Third Party Software	License Notice/Terms
<p>STMicroelectronics microcontroller support software</p>	<p>COPYRIGHT(c) 2015 STMicroelectronics  Redistribution and use in source and binary forms, with or without modification, are permitted provided that the following conditions are met:  Redistributions of source code must retain the above copyright notice, this list of conditions and the following disclaimer.  Redistributions in binary form must reproduce the above copyright notice, this list of conditions and the following disclaimer in the documentation and/or other materials provided with the distribution.  Neither the name of STMicroelectronics nor the names of its contributors may be used to endorse or promote products derived from this software without specific prior written permission.  THIS SOFTWARE IS PROVIDED BY THE COPYRIGHT HOLDERS AND CONTRIBUTORS "AS IS" AND ANY EXPRESS OR IMPLIED WARRANTIES, INCLUDING, BUT NOT LIMITED TO, THE IMPLIED WARRANTIES OF MERCHANTABILITY AND FITNESS FOR A PARTICULAR PURPOSE ARE DISCLAIMED. IN NO EVENT SHALL THE COPYRIGHT HOLDER OR CONTRIBUTORS BE LIABLE FOR ANY DIRECT, INDIRECT, INCIDENTAL, SPECIAL, EXEMPLARY, OR CONSEQUENTIAL DAMAGES (INCLUDING, BUT NOT LIMITED TO, PROCUREMENT OF SUBSTITUTE GOODS OR SERVICES; LOSS OF USE, DATA, OR PROFITS; OR BUSINESS INTERRUPTION) HOWEVER CAUSED AND ON ANY THEORY OF LIABILITY, WHETHER IN CONTRACT, STRICT LIABILITY, OR TORT (INCLUDING NEGLIGENCE OR OTHERWISE) ARISING IN ANY WAY OUT OF THE USE OF THIS SOFTWARE, EVEN IF ADVISED OF THE POSSIBILITY OF SUCH DAMAGE.</p> <p>COPYRIGHT(c) 2014 STMicroelectronics  Licensed under MCD-ST Liberty SW License Agreement V2, (the "License");  You may not use this file except in compliance with the License.  You may obtain a copy of the License at:  <a href="http://www.st.com/software_license_agreement_liberty_v2">http://www.st.com/software_license_agreement_liberty_v2</a>  Unless required by applicable law or agreed to in writing, software distributed under the License is distributed on an "AS IS" BASIS, WITHOUT WARRANTIES OR CONDITIONS OF ANY KIND, either express or implied.  See the License for the specific language governing permissions and limitations under the License.</p>
<p>FreeRTOS V9.0.0</p>	<p>Copyright (C) 2016 Real Time Engineers Ltd. All rights reserved  FreeRTOS is free software; you can redistribute it and/or modify it under the terms of the GNU General Public License (version 2) as published by the Free Software Foundation &gt;&gt;&gt;&gt; AND MODIFIED BY &lt;&lt;&lt;&lt; the FreeRTOS exception.  *****  &gt;&gt;! NOTE: The modification to the GPL is included to allow you to !&lt;&lt;  &gt;&gt;! distribute a combined work that includes FreeRTOS without being !&lt;&lt;  &gt;&gt;! obliged to provide the source code for proprietary components !&lt;&lt;  &gt;&gt;! outside of the FreeRTOS kernel. !&lt;&lt;</p>

	<p>*****</p> <p>FreeRTOS is distributed in the hope that it will be useful, but WITHOUT ANY WARRANTY; without even the implied warranty of MERCHANTABILITY or FITNESS FOR A PARTICULAR PURPOSE. Full license text is available on the following link: <a href="http://www.freertos.org/a00114.html">http://www.freertos.org/a00114.html</a></p>
LwIP v2.0.2	<p>Copyright (c) 2001-2004 Swedish Institute of Computer Science. All rights reserved.</p> <p>Redistribution and use in source and binary forms, with or without modification, are permitted provided that the following conditions are met:</p> <ol style="list-style-type: none"> <li>1. Redistributions of source code must retain the above copyright notice, this list of conditions and the following disclaimer.</li> <li>2. Redistributions in binary form must reproduce the above copyright notice, this list of conditions and the following disclaimer in the documentation and/or other materials provided with the distribution.</li> <li>3. The name of the author may not be used to endorse or promote products derived from this software without specific prior written permission.</li> </ol> <p>THIS SOFTWARE IS PROVIDED BY THE AUTHOR ``AS IS" AND ANY EXPRESS OR IMPLIED WARRANTIES, INCLUDING, BUT NOT LIMITED TO, THE IMPLIED WARRANTIES OF MERCHANTABILITY AND FITNESS FOR A PARTICULAR PURPOSE ARE DISCLAIMED. IN NO EVENT SHALL THE AUTHOR BE LIABLE FOR ANY DIRECT, INDIRECT, INCIDENTAL, SPECIAL, EXEMPLARY, OR CONSEQUENTIAL DAMAGES (INCLUDING, BUT NOT LIMITED TO, PROCUREMENT OF SUBSTITUTE GOODS OR SERVICES; LOSS OF USE, DATA, OR PROFITS; OR BUSINESS INTERRUPTION) HOWEVER CAUSED AND ON ANY THEORY OF LIABILITY, WHETHER IN CONTRACT, STRICT LIABILITY, OR TORT (INCLUDING NEGLIGENCE OR OTHERWISE) ARISING IN ANY WAY OUT OF THE USE OF THIS SOFTWARE, EVEN IF ADVISED OF THE POSSIBILITY OF SUCH DAMAGE.</p> <p>The license is available at: <a href="http://lwip.wikia.com/wiki/License">http://lwip.wikia.com/wiki/License</a></p>

## OUR PRODUCTS

AC/DC Power Supplies  
Actuator Controls/Interfaces  
Automotive Ethernet Converters  
Battery Chargers  
CAN Controls, Routers, Repeaters  
CAN/WiFi, CAN/Bluetooth, Routers  
Current/Voltage Converters  
DC/DC Power Converters  
Engine Temperature Scanners  
Ethernet/CAN Converters,  
Gateways, Switches  
Fan Drive Controllers  
Gateways, CAN/Modbus Protocols  
Gyroscope Inclinometers  
Hydraulic Valve Controllers  
Inclinometers, Triaxial  
I/O Controls  
LVDT Signal Converters  
Machine Controls  
Modbus Controls  
Motor Controls  
Power Supplies, DC/DC, AC/DC  
PWM Signal Converters/Isolators  
Resolver Signal Conditioners  
Service Tools  
Signal Conditioners, Converters  
Strain Gauge CAN Controls  
Surge Suppressors

## OUR COMPANY

Axiomatic provides electronic machine control components to the off-highway, commercial vehicle, electric vehicle, power generator set, material handling, renewable energy and industrial OEM markets. ***We innovate with engineered and off-the-shelf machine controls that add value for our customers.***

## QUALITY DESIGN AND MANUFACTURING

We have an ISO9001:2015 registered design/manufacturing facility in Canada.

## WARRANTY, APPLICATION APPROVALS/LIMITATIONS

Axiomatic Technologies Corporation reserves the right to make corrections, modifications, enhancements, improvements, and other changes to its products and services at any time and to discontinue any product or service without notice. Customers should obtain the latest relevant information before placing orders and should verify that such information is current and complete. Users should satisfy themselves that the product is suitable for use in the intended application. All our products carry a limited warranty against defects in material and workmanship. Please refer to our Warranty, Application Approvals/Limitations and Return Materials Process at <https://www.axiomatic.com/service/>.

## COMPLIANCE

Product compliance details can be found in the product literature and/or on [axiomatic.com](http://axiomatic.com). Any inquiries should be sent to [sales@axiomatic.com](mailto:sales@axiomatic.com).

## SAFE USE

All products should be serviced by Axiomatic. Do not open the product and perform the service yourself.



This product can expose you to chemicals which are known in the State of California, USA to cause cancer and reproductive harm. For more information go to [www.P65Warnings.ca.gov](http://www.P65Warnings.ca.gov).

## SERVICE

All products to be returned to Axiomatic require a Return Materials Authorization Number (RMA#) from [sales@axiomatic.com](mailto:sales@axiomatic.com). Please provide the following information when requesting an RMA number:

- Serial number, part number
- Hours of operation, description of problem
- Wiring set up diagram, application and other comments as needed

## DISPOSAL

Axiomatic products are electronic waste. Please follow your local environmental waste and recycling laws, regulations and policies for safe disposal or recycling of electronic waste.

## CONTACTS

**Axiomatic Technologies Corporation**  
5915 Wallace Street  
Mississauga, ON  
CANADA L4Z 1Z8  
TEL: +1 905 602 9270  
FAX: +1 905 602 9279  
[www.axiomatic.com](http://www.axiomatic.com)  
[sales@axiomatic.com](mailto:sales@axiomatic.com)

**Axiomatic Technologies Oy**  
Höytämöntie 6  
33880 Lempäälä  
FINLAND  
TEL: +358 103 375 750  
FAX: +358 3 3595 660  
[www.axiomatic.com](http://www.axiomatic.com)  
[salesfinland@axiomatic.com](mailto:salesfinland@axiomatic.com)