



USER MANUAL UMAX181001
Version V1

DATA LOGGER

**4 Thermocouple, 7 Analog and 3 A/D Inputs
With Dual CAN
CANopen®**

USER MANUAL

P/N: AX181001

In Europe:
Axiomatic Technologies Oy
Höytämöntie 6
33880 LEMPÄÄLÄ - Finland
Tel. +358 103 375 750
Fax. +358 3 3595 660
www.axiomatic.fi

In North America:
Axiomatic Technologies Corporation
5915 Wallace Street
Mississauga, ON Canada L4Z 1Z8
Tel. 1 905 602 9270
Fax. 1 905 602 9279
www.axiomatic.com

ACRONYMS

AI	Analog Input
CAN	Controller Area Network
CANopen®	CANopen® is a registered community trademark of CAN in Automation e.V.
CAN-ID	CAN 11-bit Identifier
CJ	Cold Junction
COB	Communication Object
CTRL	Control
DI	Digital Input
EDS	Electronic Data Sheet
EMCY	Emergency
LSB	Least Significant Byte (or Bit)
LSS	Layer Settling Service
LUT	Lookup Table
MSB	Most Significant Byte (or Bit)
NMT	Network Management
RO	Read Only Object
RPDO	Received Process Data Object
RW	Read/Write Object
SDO	Service Data Object
TC	Thermocouple
TPDO	Transmitted Process Data Object
WO	Write Only Object

REFERENCES

- [DS-301] CiA DS-301 V4.1 – CANopen® Application Layer and Communication Profile. CAN in Automation 2005
- [DS-305] CiA DS-305 V2.0 – Layer Setting Service (LSS) and Protocols. CAN in Automation 2006
- [DS-404] CiA DS-404 V1.2 – CANopen® profile for Measurement Devices and Closed Loop Controllers. CAN in Automation 2002

These documents are available from the CAN in Automation e.V. website <http://www.can-cia.org/>.

Contents

1. OVERVIEW OF CONTROLLER	6
1.1. DESCRIPTION OF DATA LOGGER	6
1.2. THERMOCOUPLE INPUT FUNCTION BLOCK	8
1.3. DIGITAL INPUT FUNCTION BLOCK	10
1.4. ANALOG INPUT FUNCTION BLOCK	13
1.5. LOOKUP TABLE FUNCTION BLOCK	24
1.5.1. X-Axis, Input Data Response	25
1.5.2. Y-Axis, Lookup Table Output	25
1.5.3. Point to Point Response	26
1.5.4. X-Axis, Time Response	27
1.6. PROGRAMMABLE LOGIC FUNCTION BLOCK	29
1.6.1. Conditions Evaluation	32
1.6.2. Table Selection	33
1.6.3. Logic Block Output	36
1.7. MATH FUNCTION BLOCK	37
1.8. MISCELLANEOUS FUNCTION BLOCK	40
2. INSTALLING INSTRUCTIONS	42
2.1. DIMENSIONS AND PINOUT	42
2.2. INSTALLATION INSTRUCTIONS	44
3. CANOPEN® OBJECT DICTIONARY	45
3.1. NODE ID AND BAUDRATE	45
3.1.1. LSS Protocol to Update	45
3.2. COMMUNICATION OBJECTS (DS-301 AND DS-404)	50
3.2.1. Object 1000h: Device Type	52
3.2.2. Object 1001h: Error Register	52
3.2.3. Object 1002h: Manufacturer Status Register	53
3.2.4. Object 1003h: Pre-Defined Error Field	53
3.2.5. Object 100Ch: Guard Time	56
3.2.6. Object 100Dh: Life Time Factor	57
3.2.7. Object 1010h: Store Parameters	57
3.2.8. Object 1011h: Restore Parameters	58
3.2.9. Object 1016h: Consumer Heartbeat Time	60
3.2.10. Object 1017h: Producer Heartbeat Time	61
3.2.11. Object 1018h: Identity Object	61
3.2.12. Object 1020h: Verify Configuration	63
3.2.13. Object 1029h: Error Behaviour	63
3.2.14. RPDO Behaviour	65
3.2.15. TPDO Behaviour	67
3.3. APPLICATION OBJECTS (DS-404)	71
3.3.1. Object 6020h: DI Read State 1 Input Lines	72
3.3.2. Object 6100h: TC Input Field Value	72
3.3.3. Object 6130h: TC Input Process Value	73
3.3.4. Object 6110h: AI Sensor Type	73
3.3.5. Object 6112h: AI Operating Mode	74
3.3.6. Object 6132h: AI Decimal Digits PV	75
3.3.7. Object 61A0h: AI Filter Type	75
3.3.8. Object 61A1h: AI Filter Constant	76
3.3.9. Object 7100h: AI Input Field Value	76
3.3.10. Object 7120h: AI Input Scaling 1 FV	77
3.3.11. Object 7121h: AI Input Scaling 1 PV	78
3.3.12. Object 7122h: AI Input Scaling 2 FV	78
3.3.13. Object 7123h: AI Input Scaling 2 PV	79
3.3.14. Object 7130h: AI Input Process Value	79
3.3.15. Object 7148h: AI Span Start	80

3.3.16	Object 7149h: AI Span End	81
3.4	MANUFACTURER OBJECTS	82
3.4.1	Object 2010h: DI Polarity 1 Input Line	85
3.4.2	Object 2020h: DI Pullup Mode 1 Input Line	85
3.4.3	Object 2030h: DI Debounce Filter 1 Input Line	86
3.4.4	Object 2100h: AI Input Range	86
3.4.5	Object 2101h: AI Number of Pulses Per Revolution	87
3.4.6	Object 2102h: AI Decimal Digits FV	88
3.4.7	Object 2103h: AI Filter Frequency for ADC	88
3.4.8	Object 2110h: AI Error Detect Enable	89
3.4.9	Object 2111h: AI Error Clear Hysteresis	90
3.4.10	Object 2112h: AI Error Reaction Delay	90
3.4.11	Object 2120h: AI Third-Order Filter Power	91
3.4.12	Object 2121h: AI Third-Order Filter Input Coefficient N0	92
3.4.13	Object 2122h: AI Third-Order Filter Input Coefficient N1	92
3.4.14	Object 2123h: AI Third-Order Filter Input Coefficient N2	92
3.4.15	Object 2124h: AI Third-Order Filter Input Coefficient N3	92
3.4.16	Object 2125h: AI Third-Order Filter Output Coefficient N1	92
3.4.17	Object 2126h: AI Third-Order Filter Output Coefficient N2	92
3.4.18	Object 2127h: AI Third-Order Filter Output Coefficient N3	92
3.4.19	Object 2160h: TC Cold Junction Enabled	93
3.4.20	Object 2161h: TC Cold Junction Input Process Value	94
3.4.21	Object 2162h: TC Cold Junction Output Field Value	94
3.4.22	Object 2170h: TC Low Temperature Warning	95
3.4.23	Object 2171h: TC High Temperature Warning	95
3.4.24	Object 2172h: TC Low Temperature Shutdown	96
3.4.25	Object 2173h: TC High Temperature Shutdown	97
3.4.26	Object 2174h: TC Error Clear Hysteresis	97
3.4.27	Object 2500h: EC Extra Received Process Value	98
3.4.28	Object 2502h: EC Decimal Digits PV	98
3.4.29	Object 2520h: EC Scaling 1 PV	99
3.4.30	Object 2522h: EC Scaling 2 PV	100
3.4.31	Object 3yz0h: LTyz Input X-Axis Source	100
3.4.32	Object 3yz1h: LTyz Input X-Axis Number	101
3.4.33	Object 3yz2h: LTyz Auto Repeat	101
3.4.34	Object 3yz3h: LTyz X-Axis Decimal Digits PV	102
3.4.35	Object 3yz4h: LTyz Y-Axis Decimal Digits PV	102
3.4.36	Object 3yz5h: LTyz Point Response	103
3.4.37	Object 3yz6h: LTyz Point X-Axis PV	103
3.4.38	Object 3yz7h: LTyz Point Y-Axis PV	104
3.4.39	Object 3yz8h: LTyz Output Y-Axis PV	105
3.4.40	Object 3300h: Logic Block Enable	105
3.4.41	Object 3310h: Logic Block Selected Table	106
3.4.42	Object 3320h: Logic Block Output PV	106
3.4.43	Object 3x01h: LB(x-3) Lookup Table Numbers	107
3.4.44	Object 3x02h: LB(x-3) Function Logical Operator	107
3.4.45	Object 3x11h: LB(x-3) Function A Condition 1	108
3.4.46	Object 3x12h: LB(x-3) Function A Condition 2	108
3.4.47	Object 3x13h: LB(x-3) Function A Condition 3	108
3.4.48	Object 3x21h: LB(x-3) Function B Condition 1	108
3.4.49	Object 3x22h: LB(x-3) Function B Condition 2	108
3.4.50	Object 3x23h: LB(x-3) Function B Condition 3	108
3.4.51	Object 3x31h: LB(x-3) Function C Condition 1	108
3.4.52	Object 3x32h: LB(x-3) Function C Condition 2	108
3.4.53	Object 3x33h: LB(x-3) Function C Condition 3	108
3.4.54	Object 4000h: Math Function Enable	110
3.4.55	Object 4021h: Math Output Scaling 1 PV	110
3.4.56	Object 4023h: Math Output Scaling 2 PV	111

3.4.57	Object 4030h: Math Output Process Value.....	111
3.4.58	Object 4032h: Math Output Decimal Digits PV	112
3.4.59	Object 4y00h: Math Y Input Source	113
3.4.60	Object 4y01h: Math Y Input Number	113
3.4.61	Object 4y02h: Math Y Input Function Number	114
3.4.62	Object 4y03h: Math Y Input Decimal Digits FV	115
3.4.63	Object 4y20h: Math Y Input Scaling 1 FV	115
3.4.64	Object 4y22h: Math Y Input Scaling 2 FV	116
3.4.65	Object 4y40h: Math Y Input Gain	117
3.4.66	Object 4y50h: Math Y Operator	117
3.4.67	Object 5010h: Constant Field Value	118
3.4.68	Object 5020h: Power Supply Field Value	121
3.4.69	Object 5021h: Enable Error Detection on Power Supply	121
3.4.70	Object 5022h: Under Voltage Threshold.....	122
3.4.71	Object 5023h: Over Voltage Threshold	122
3.4.72	Object 5024h: Hysteresis to Clear Supply Fault	122
3.4.73	Object 5030h: Processor Temperature Field Value	123
3.4.74	Object 5031h: Enable Error Detection on Temperature	123
3.4.75	Object 5032h: Over Temperature Threshold	124
3.4.76	Object 5033: Hysteresis to Clear Temperature Fault.....	124
3.4.77	Object 5550h: Enable Automatic Updates	124
3.4.78	Object 5555h: Start in Operational Mode.....	125
3.4.79	Object 5B50h: Change Baud Rate	125
3.4.80	Object 5B51h: Change Node ID.....	126
4	TECHNICAL SPECIFICATIONS	127
5	VERSION HISTORY	129

1. OVERVIEW OF CONTROLLER

1.1. Description of Data Logger

The Data Logger (TC/Analog Inputs to CAN Controller) receives inputs from engine coolant, fuel and differential pressure sensors, engine temperature sensors, thermistors as well as thermocouples and is networked to a CAN bus-based control system. It has 4 Thermocouple Inputs, 7 Analog Inputs and 3 Universal Inputs. Seven +5V references (10 mA) are provided to power the sensors. The 2 CANopen® ports are isolated from signal inputs and thermocouple inputs. Each measured input signal can be sent to either of the two CANopen® buses.

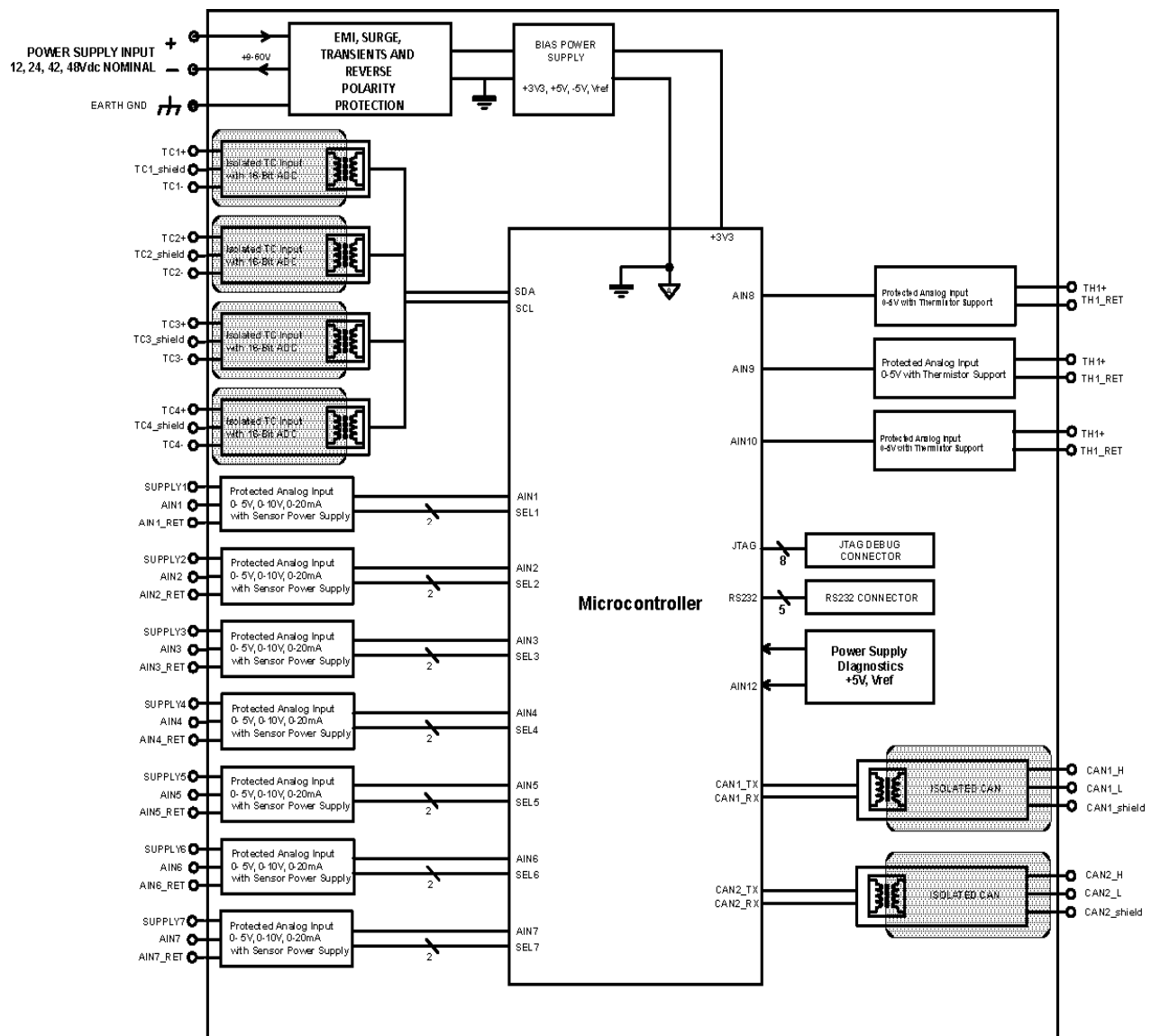

Figure 1A – Hardware Functional Block Diagram

All I/O and logical function blocks on the unit are inherently independent from one another but can be programmed to interact in many ways. All objects are user configurable using standard commercially available tools that can interact with a CANopen® Object Dictionary via an .EDS file.

1.2. Thermocouple Input Function Block

The unit has 4 Thermocouple inputs, each input supports temperature measurement with various thermocouples types. The TC type can be programmed using object 6110h **AI Sensor Type**. Sub-index 1-10 in object 6110h are used for Analog Inputs which will be described in Section 1.3. The last 4 sub-indices, sub-index 11-14 are used for setting TC type. The options for these sub-indices are shown in Table 1 with the default value bolded.

Value	Meaning
1	Type J
2	Type K
4	Type N
5	Type R
6	Type S
7	Type T
8	Type B
9	Type E

Table 1 – Thermocouple Type Options

A high accuracy digital temperature sensor is placed next to thermocouple connectors to provide cold junction compensation. By default, all temperatures are compensated for the cold junction temperature, but it is possible to choose not to use cold junction compensation, by setting object 2160h **TC CJ Enabled** to *False*. Object 2161h **TC CJ PV** holds the cold junction value in Degree Celsius and 2162h **TC CJ Output FV** holds the cold junction value in mV. Since cold junction in degree will be the same for different TC type but the cold junction mV value will change as TC type changes, object 2162h has sub-indices for different TC. Both 2161h and 2162h are mappable to TPDO and 2161h is mapped to TPDO6 by default.

An analog to-digital converter, with programmable gain, is used to measure the thermocouple input voltage. As the voltage changes, the controller will adjust the gain accordingly to get the best resolution and accuracy of the signal. The raw microvolt reading will be written to object 6130h **TC Input PV**. The controller will process the raw microvolt reading and converts it into a temperature value in degrees Celsius, which is written to read-only mappable object 6100h **TC Input FV**. These objects are mappable to TPDO, but only 6100h is mapped to TPDO4 and TPDO5 by default.

Thermocouple block has a few objects associated with fault detection. Once an overrange reading is received from the ADC, an open circuit fault is flagged. Other faults that the controller can detect and flag are determined by the values in objects 2170h **TC Low Temperature Warning**, 2171h **TC High Temperature Warning**, 2172h **TC Low Temperature Shutdown** and 2173h **TC High Temperature Shutdown**. When the value in 6100h is not in the range limited by these objects, an out of range flag will be set. Then an EMCY message will be added to object 1003h. The EMCY will be

discussed in more detail in Section 3.2.4 and 3.2.13. Once the out of range fault has been detected, the flag will be cleared only once the TC comes back into range. Object 2174h **TC Error Clear Hysteresis** is used for determining how much change in the TC will be considered error clear.

1.3. Digital Input Function Block

The digital input (DI) function block only becomes applicable on the input when object 6112h, **AI Operation**, is set to a digital input response.

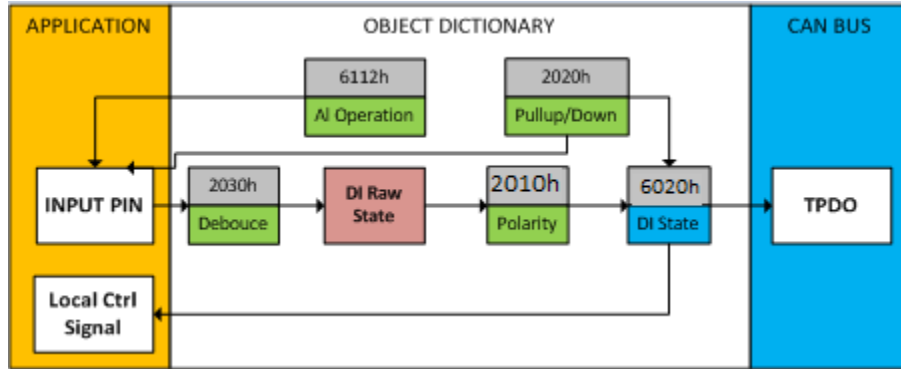

Figure 2 – Digital Input Objects

When 6112h is set to 10 = Digital Input (only Input 8-10 are available for this option), object 2020h **DI Pullup Mode** will enable/disable the internal pullup resistors. The options for object 2020h are shown in Table 2, with the default bolded.

Value	Meaning
0	Pullup Disabled (high impedance input)
1	Pullup Resistor Enabled

Table 2 – DI Pullup Options

Figure 3 shows the hysteresis on the input when switching a discrete signal. A digital input can be switched up to +Vcc .

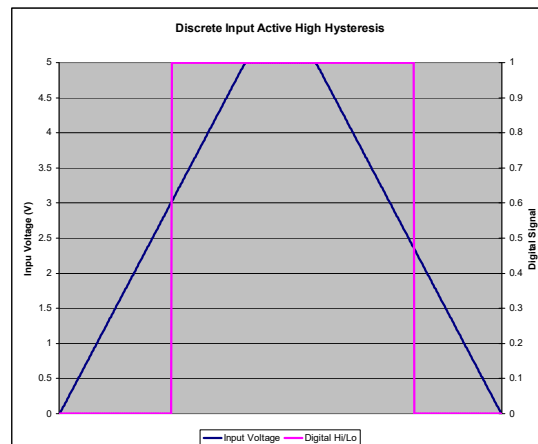

Figure 3 – Discrete Input Hysteresis

Object 2030h **DI Debounce Filter** is applied to the input before the state is read by the processor. The options for object 2030h are shown in Table 3, with the default bolded.

Value	Meaning
0	Filter Disabled
1	Filter 111ns
2	Filter 1.78 us
3	Filter 14.22 us

Table 3 – DI Debounce Filter Options

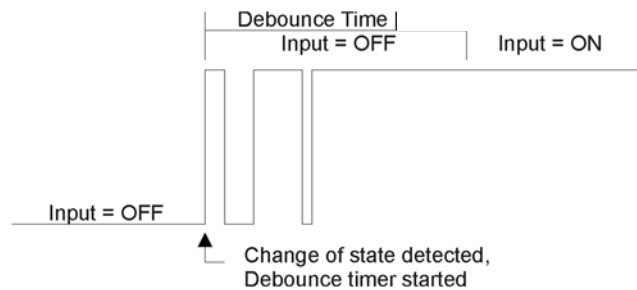

Figure 4 – Digital Input Debouncing

Once the raw state has been evaluated, the logical state of the input is determined by **object 2010h DI Polarity**. The options for object 2010h are shown in Table 4. The 'calculated' state of the DI that will be written to read-only object 6020h **DI Read State** will be a combination of active high/low and the polarity selected. By default, normal on/off logic is used.

Value	Meaning	Input Signal	State
0	Normal On/Off	HIGH	ON
		LOW or Open	OFF
1	Inverse On/Off	HIGH	OFF
		LOW or Open	ON
2	Latched Logic	HIGH to LOW	No Change
		LOW to HIGH	State Change (i.e. OFF to ON)

Table 4 – DI Polarity Options versus DI State

There is another type of 'digital' input that can be selected when 6112h is set to 20 = Analog On/Off. However, in this case, the input is still configured as an analog input, and therefore the objects from the Analog Input (AI) block are applied instead of those discussed above. (Apply to all the inputs, not only Input 8 to 10 in this case) Here, objects 2010h, 2020h and 2030h are ignored, and 6020h is written as per the logic shown in Figure 5. In this case, the MIN parameter is set by object 7120h **AI Scaling 1 FV**, and the MAX is set by 7122h **AI Scaling 2 FV**.

For all other operating modes, object 6020h will always be zero.

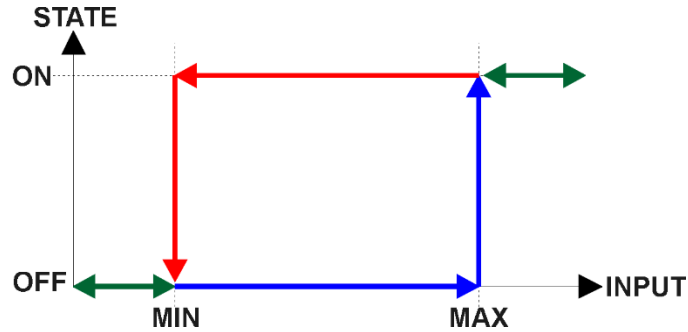

Figure 5 – Analog Input Read as Digital

1.4. Analog Input Function Block

The analog input (AI) function block is the default logic associate with all the 10 inputs.

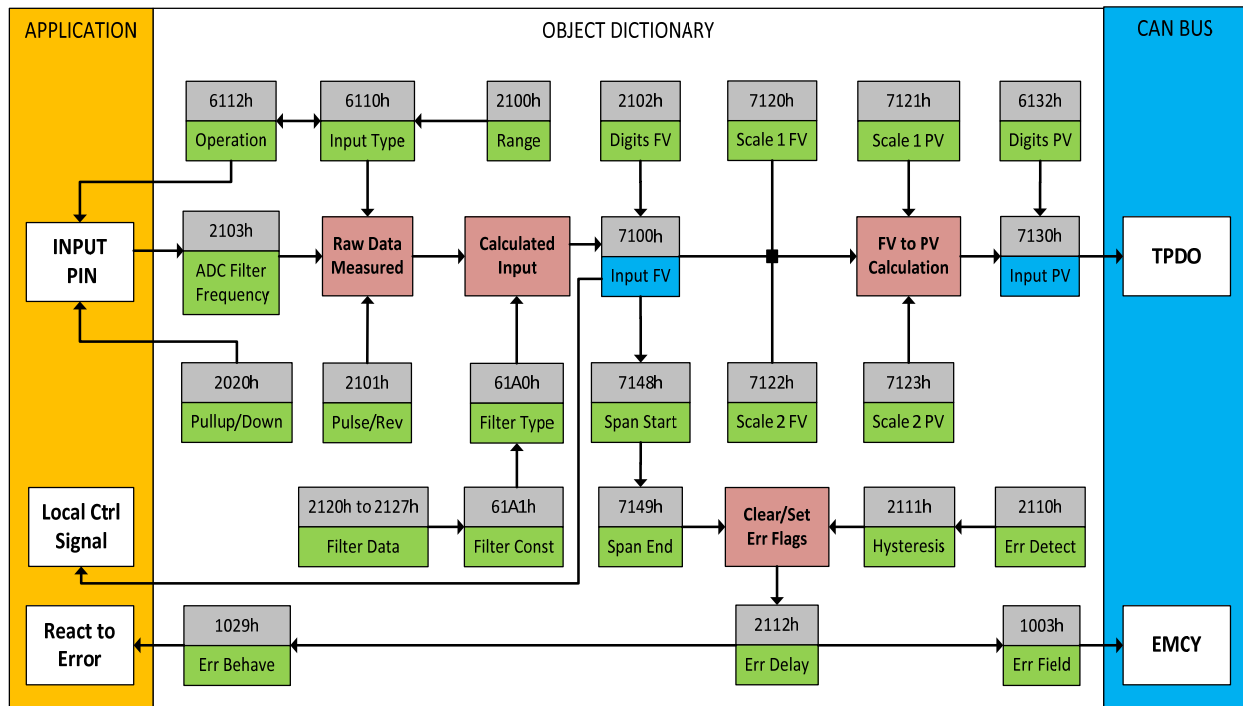

Figure 6 – Analog Input Objects

Object 6112h, **AI Operating Mode** determines whether the AI or DI function block is associated with an input. The options for object 6112h are shown in Table 5. No values other than what are shown here will be accepted. By default, all the inputs are set to 1, *Normal Operation*. And 10, *Digital Input (On/Off)* will only be available on inputs 8-10.

Value	Meaning
0	Channel Off
1	Normal Operation (analog)
10	Digital Input (On/Off)
20	Analog On/Off

Table 5 – AI Operating Mode Options

The most important object associate with the AI function block is object 6110h **AI Sensor Type**. By changing this value, and associated with it, the object 2100h **AI Input Range**, other objects will be automatically updated by the controller. The options for object 6110h are shown in Table 6, and no values other than what are shown here will be accepted. The inputs are setup to measure voltage by default. Frequency and PWM types are only applicable for Input 8 and 9.

Value	Meaning
40	Voltage Input
50	Current Input
60	Frequency Input (or RPM)
10000	PWM Input

Table 6 – AI Sensor Type Options

The allowable ranges will depend on the input sensor type and the input selected. For Voltage type, 0-10V will only be available for Input 1-7. Table 7 shows the relationship between the sensor type, and the associated range options. The default value for each range is bolded, and object 2100h **AI Range** will automatically be updated with this value when 6110h is changed. The grayed-out cells mean that the associate value is not allowed for the range object when that sensor type has been selected.

Value	Voltage	Current	Frequency	PWM
0	0 to 5V	0 to 20mA	0.5Hz to 50kHz	
1	0 to 10V	4 to 20mA		

Table 7 – AI Input Range Options Depending on Sensor Type

Not all objects apply to all input types. For example, object 2103h **AI Filter Frequency for ADC** is only applicable when a voltage or a current type is being measured. In these cases, the ADC will automatically filter as per Table 8, and is set for 50Hz noise rejection by default.

Value	Meaning
0	Input Filter Off
1	Filter 50Hz
2	Filter 60Hz
3	Filter 50Hz and 60Hz

Table 8 – ADC Filter Frequency Options

Conversely, frequency and PWM inputs use object 2020h **DI Pullup Mode** (see Table 1) while the other input types set this object to zero. Also, a frequency input can be automatically turned into an RPM measurement instead simply by setting object 2101h **AI Number of Pulses Per Revolution** to a non-zero value. All other input types ignore this object.

Regardless of type, however, all analog inputs can be further filtered once the raw data has been measured (either from ADC or Timer.) Object 61A0h **AI Filter Type** determines what kind of filter is used per Table 9. By default, additional software filtering is disabled.

Value	Meaning
0	No Filter
1	Moving Average
2	Repeating Average
3	Third-Order Low Pass

Table 9 – AI Filter Type Options

Object 61A1h **AI Filter Constant** is used with all three types of filters as per the formulas below:

Calculation with no filter:

Value = Input

The data is simply a ‘snapshot’ of the latest value measured by the ADC or timer.

Calculation with the moving average filter:

$$\text{Value}_N = \text{Value}_{N-1} + \frac{(\text{Input} - \text{Value}_{N-1})}{\text{FilterConstant}}$$

This filter is called every 1ms. The value FilterConstant stored in object 61A1h is 10 by default.

Calculation with the repeating average filter:

$$\text{Value} = \frac{\sum \text{Input}_N}{N}$$

At every reading of the input value, it is added to the sum. At every Nth read, the sum is divided by N, and the result is the new input value. The value and counter will be set to zero for the next read. The value of N is stored in object 61A1h which is 10 by default. This filter is called every 1ms.

Calculation with the 3rd Order Low Pass filter:

$$\text{Value}_N = \frac{[C_{IN0} * \text{Input}_N + C_{IN1} * \text{Input}_{N-1} + C_{IN2} * \text{Input}_{N-2} + C_{IN3} * \text{Input}_{N-3} + C_{OUT1} * \text{Value}_{N-1} + C_{OUT2} * \text{Value}_{N-2} + C_{OUT3} * \text{Value}_{N-3}]}{2^{\text{Power}}}$$

C_{IN0} Coefficient for Input(n)

C_{IN1} Coefficient for Input(n-1)

C_{IN2} Coefficient for Input(n-2)

C_{IN3} Coefficient for Input(n-3)

C_{OUT1} Coefficient for Output(n-1)

C_{OUT2} Coefficient for Output(n-2)

C_{OUT3} Coefficient for Output(n-3)

This filter uses 16-bit fixed point math. Object 2120h **AI Third-Order Filter Power** tells the controller the shift value used when the coefficients were selected.

The value of object 61A1h determines how often the filter is called (in ms) and is set to 10 by default. In between calls, the data of the input signal is the value which was calculated the last time the filter was called. The filter coefficients are stored in objects 2121h to 2127h.

The value from the filter is shifted according to read-only object 2102h **AI Decimal Digits FV** and then written to read-only object 7100h **AI Input Field Value**.

The value of 2102h will depend on the AI Sensor Type and Input Range selected and will be automatically updated per Table 10 when either 6110h or 2100h are changed. All other objects associated with the input field value also apply this object. These objects are 7120h **AI Scaling 1 FV**, 7122h **AI Scaling 2 FV**, 7148h **AI Span Start**, 7149h **AI Span End**, and 2111h **AI Error Clear Hysteresis**. These objects are also automatically updated when the Type or Range is changed.

Sensor Type and Range	Decimal Digits
Voltage: All Ranges	3 [mV]
Current: All Ranges	0 [mA]
Frequency: 0.5Hz to 50kHz	0 [Hz]
Frequency: RPM Mode	1 [0.1 RPM]
PWM	1 [0.1 %]
Digital Input	0 [On/Off]

Table 10 – AI Decimal Digits FV Depending on Sensor Type

It is the 7100h **AI Input Field Value** which is used by the application for error detection, and as a control signal for other logic blocks. Object 7100h is mappable to TPDO and is mapped to TPDO1, TPDO2, TPDO3 by default.

Read-only object 7130h **AI Input Process Value** is also mappable. However, the default values for objects 7121h **AI Scaling 1 PV** and 7123h **AI Scaling 2 PV** are set to equal 7120h and 7122h respectively, while object 6132h **AI Decimal Digits PV** is automatically initialize to equal 2102h. This means that the default relationship between the FV and PV is one-to-one, so object 7130h is not mapped to a TPDO by default.

Should a different linear relationship between what is measured versus what is sent to the CANopen® bus be desired, objects 6132h, 7121h and 7123h can be changed. The linear relationship profile is shown in Figure 7 below. Should a non-linear response be desired, the lookup table function block can be used instead, as described in section 1.5.

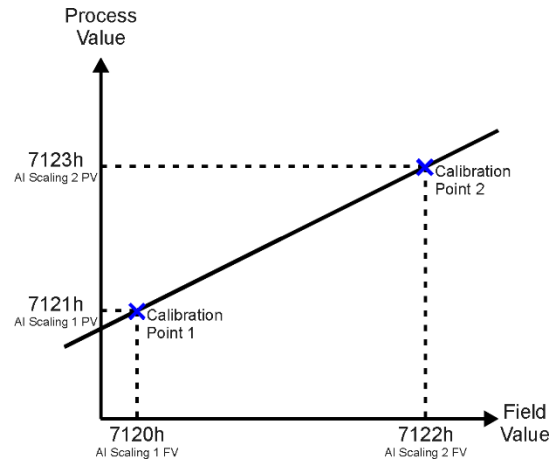

Figure 7 – Analog Input Linear Scaling FV to PV

As stated earlier, the FV scaling objects are automatically updated with the Sensor Type or Range changes. This is because objects 7120h and 7122h are not only used in a linear conversion from FV to PV as described above, but also as the minimum and maximum limits when the input is used to control another logic block. Therefore, the values in these objects are important, even when the 7130h **AI Input Process Value** object is not being used.

The objects 7138h **AI Span Start** and 7149h **AI Span End** are used for fault detection, so they are also automatically updated for sensible values as the Type/Range changes. The object 2211h **AI Error Clear Hysteresis** is also updated, as it too is measured in the same unit as the AI Input FV object.

Table 11 lists the default values that are loaded into objects 7120h, 7122h, 7148h, 7149h, and 2111h for each Sensor Type and Input Range combination. Recall that these objects all have the decimal digits applied to them as outlined in Table 10.

Sensor Type/ Input Range	7148h AI Span Start (i.e. Error Min)	7120h AI Scaling 1 FV (i.e. Input Min)	7122h AI Scaling 2 FV (i.e. Input Max)	7149h AI Span End (i.e. Error Max)	2111h Error Clear Hysteresis
Voltage: 0 to 5V	200 [mV]	500 [mV]	4500 [mV]	4800 [mV]	100 [mV]
Voltage: 0 to 10V	200 [mV]	500 [mV]	9500 [mV]	9800 [mV]	200 [mV]
Current: 0 to 20mA	0 [mA]	0 [mA]	20 [mA]	21 [mA]	1 [mA]
Current: 4 to 20mA	3 [mA]	4 [mA]	20 [mA]	21 [mA]	1 [mA]
Freq: 0.5Hz to 50kHz	100 [Hz]	150 [Hz]	30000 [Hz]	32000 [Hz]	5 [Hz]
Freq: RPM Mode	500 [0.1RPM]	1000 [0.1RPM]	30000 [0.1RPM]	33000 [0.1RPM]	100 [0.1RPM]
PWM: 0 to 100%	10 [0.1%]	50 [0.1%]	950 [0.1%]	990 [0.1%]	1 [0.1%]
Digital Input	OFF	OFF	ON	ON	0

Table 11 – AI Object Defaults Based on Sensor Type and Input Range

It might not be desired in particular application for the automatic updating of objects when a key object is changed, i.e. AI Sensor Type. In this case, object 5550h **Enable Automatic Updates** can be set to FALSE (true by default) in which case changing an object will have no impact on any other objects. In this mode, the user must manually change all the objects for sensible values, or the controller will not work as expected.

When changing these objects, Table 12 outlines the range constraints placed on each based on its Sensor Type and Input Range combination selected. In all cases, the MAX value is the upper end of the range (i.e. 5V or) Object 7122h cannot be set higher than MAX, whereas 7149h can be set up to 110% of MAX. Object 2111h on the other hand can only be set up to maximum value of 10% of MAX. Table 12 uses the base unit of the input, but recall the limits will also have object 2102h apply to them as per Table 10.

Sensor Type/ Input Range	7148h	7120h	7122h	7149h	2111h
Voltage: 0 to 5V and 0 to 10V Current: 0 to 20mA and 4 to 20mA RPM: 0 to 6000RPM PWM: 0 to 100%	0 to 7120h	7148h to 7122h	7120h to 7149h If(7149h>MAX) 7120h to MAX	7122h to 110% of MAX	10% of MAX
Current: 4 to 20mA	0 to 7120h	7148h to 7122h If(7148h<4mA) 4mA to 7122h			
Freq: 0.5Hz to 50kHz	0.1Hz to 7120h	7148h to 7122h If(7148h<0.5Hz) 0.5Hz to 7122h			

Table 12 – AI Object Ranges Based on Sensor Type and Input Range

The last objects associated with the analog input block left to discuss are those associated with fault detection. Should the calculated input (after measuring and filtering) fall outside of the allowable range, as defined by the AI Span Start and AI Span End objects, an error flag will be set in the application if and only if object 2110h **AI Error Detect Enabled** is set to TRUE (1).

When (7100h **AI Input Field Value** < 7148h **AI Span Start**), an “Out of Range Low” flag is set. If the flag stays active for the 2112h **AI Error Reaction Delay** time, an Input Overload Emergency (EMCY) message will be added to object 1003h **Pre-Defined Error Field**. Similarly, when (7100h **AI Input Field Value** > 7149h **AI Span End**), an “Out of Range High” flag is set and will create an EMCY message should it stay active throughout the delay period. In either case, the application will react to the EMCY message as defined by object 1029h **Error Behavior** at the sub-index corresponding to an Input Fault. Refer to section 3.2.4 and 3.2.13 for more information about objects 1003h and 1029h (It only applies to the 7 Analog Inputs).

Once the fault has been detected, the associate flag will be cleared only once the input comes back into range. Object 2111h **AI Error Clear Hysteresis** is used here so that the error flag will not be set/cleared continuously while the AI Input FV hovers around the AI Span Start/End value.

To clear an “Out of Range Low” flag, AI Input FV \geq (AI Span Start + AI Error Clear Hysteresis)

To clear an “Out of Range High” flag, AI Input FV \leq (AI Span End - AI Error Clear Hysteresis)

Both flags cannot be active at once. Setting either one of these flags automatically clears the other.

The controller allows for the PV input can be selected from the list of the logical function blocks supported by the controller. As a result, any output from one function block can be selected as the control source for another. Keep in mind that not all options make sense in all cases, but the complete list of control sources is shown in Table 13.

Value	Meaning
0	Control Source Not Used (Ignored)
1	CANopen® Message (RPDO)
2	Analog Input Function Block
3	Thermocouple Cold Junction mV Measured
4	Thermocouple Degree Measured
5	Constant Function Block
6	Lookup Table Function Block
7	Mathematical Function Block
8	Programmable Logic Function Block
9	Power Supply Measured
10	Processor Temperature Measured

Table 13 – Control Source Options

In addition to a source, each control also has a number which corresponds to the sub-index of the function block in question. Table 14 outlines the ranges supported for the number objects, depending on the source that had been selected.

Control Source	Range	Object (Meaning)
Control Source Not Used	0	Ignored
CANopen® Message (RPDO)	1	2500h sub-index 1 (Extra Received PV 1)
	2	2500h sub-index 2 (Extra Received PV 2)
	3	2500h sub-index 3 (Extra Received PV 3)
	4	2500h sub-index 4 (Extra Received PV 4)
	5	2500h sub-index 5 (Extra Received PV 5)
	6	2500h sub-index 6 (Extra Received PV 6)
	7	2500h sub-index 7 (Extra Received PV 7)
	8	2500h sub-index 8 (Extra Received PV 8)
	9	2500h sub-index 9 (Extra Received PV 9)
	10	2500h sub-index 10 (Extra Received PV 10)
	11	2500h sub-index 11 (Extra Received PV 11)
	12	2500h sub-index 12 (Extra Received PV 12)
	Analog Input Function Block	1
2		7100h sub-index 2
3		7100h sub-index 3
4		7100h sub-index 4
5		7100h sub-index 5
6		7100h sub-index 6
7		7100h sub-index 7
8		7100h sub-index 8 or 6020h sub-index 8**
9		7100h sub-index 9 or 6020h sub-index 9**
10		7100h sub-index 10 or 6020h sub-index 10**
<i>** Depending on AI Operation selected, either the AI Input FV or DI Read State will be used</i>		
Thermocouple Cold Junction Function Block (mV)	1	2162h sub-index 1
	2	2162h sub-index 2
	3	2162h sub-index 3
	4	2162h sub-index 4
Thermocouple Function Block (Degree)	1	6100h sub-index 1
	2	6100h sub-index 2
	3	6100h sub-index 3
	4	6100h sub-index 4
Constant Function Block	1	5010h sub-index 1 (always FALSE)
	2	5010h sub-index 2 (always TRUE)
	3	5010h sub-index 3 (Constant FV 3)
	4	5010h sub-index 4 (Constant FV 4)
	5	5010h sub-index 5 (Constant FV 5)
	6	5010h sub-index 6 (Constant FV 6)
	7	5010h sub-index 7 (Constant FV 7)

	8	5010h sub-index 8 (Constant FV 8)
	9	5010h sub-index 9 (Constant FV 9)
	10	5010h sub-index 10 (Constant FV 10)
	11	5010h sub-index 11 (Constant FV 11)
	12	5010h sub-index 12 (Constant FV 12)
	13	5010h sub-index 13 (Constant FV 13)
	14	5010h sub-index 14 (Constant FV 14)
	15	5010h sub-index 15 (Constant FV 15)
Lookup Table Function Block	1	3018h (Lookup Table 1 Output Y-Axis PV)
	2	3028h (Lookup Table 2 Output Y-Axis PV)
	3	3038h (Lookup Table 3 Output Y-Axis PV)
	4	3048h (Lookup Table 4 Output Y-Axis PV)
	5	3058h (Lookup Table 5 Output Y-Axis PV)
	6	3068h (Lookup Table 6 Output Y-Axis PV)
	7	3078h (Lookup Table 7 Output Y-Axis PV)
	8	3088h (Lookup Table 8 Output Y-Axis PV)
	9	3098h (Lookup Table 9 Output Y-Axis PV)
	10	3108h (Lookup Table 10 Output Y-Axis PV)
	11	3118h (Lookup Table 11 Output Y-Axis PV)
	12	3128h (Lookup Table 12 Output Y-Axis PV)
Mathematical Function Block	1	4030h sub-index 1 (Math Output PV 1)
	2	4030h sub-index 2 (Math Output PV 2)
	3	4030h sub-index 3 (Math Output PV 3)
	4	4030h sub-index 4 (Math Output PV 4)
	5	4030h sub-index 5 (Math Output PV 5)
	6	4030h sub-index 6 (Math Output PV 6)
Programmable Logic Function Block	1	3xy8h (Lookup Table Selected by Logic 1)
	2	3xy8h (Lookup Table Selected by Logic 2)
	3	3xy8h (Lookup Table Selected by Logic 3)
	4	3xy8h (Lookup Table Selected by Logic 4)
<i>NOTE: The following options should be considered for diagnostic feedback, and should not be selected as a control source for logic inputs (i.e. lookup table X-Axis)</i>		
Power Supply Measured	N/A	5020h (Power Supply FV)
Processor Temperature Measured	N/A	5030h (Processor Temperature FV)

Table 14 – Control Number Options Depending on Source Selected

When using any control source as the X-Axis input to a function block, the corresponding scaling limits are defined as per Table 15. It is the responsibility of the user to make sure that the scaling objects for any function block are setup appropriately depending on the source selected for the X-Axis input.

Control Source	Scaling 1	Scaling 2	Dec Digits
CANopen Message – Num 1 to 12	2520h	2522h	2502h
Analog Input Function Block 1-10	7120h	7122h	6132h
Thermocouple Cold Junction Function Block 1 to 4	-40 (fixed)	210 (fixed)	1 (fixed)
Thermocouple Function Block 1 to 4	2170h	2171h	1 (fixed)
Constant Function Block	N/A	N/A	N/A (float)
Lookup Table yz Function Block (where yz = 01 to 12)	0 or lowest from 3yz6h ^(*)	100 or highest from 3yz6h ^(**)	3yz3h
Mathematical Function	4021h	4023h	4032h
Programmable Logic Function	0%	100%	1 (fixed)
Power Supply Measured	N/A	N/A	1 (fixed)
Processor Temperature Measured	N/A	N/A	1 (fixed)

() - Whichever value is smaller; (**) - Whichever value is larger*

Table 15 – Scaling Limits per Control Source

1.5. Lookup Table Function Block

The lookup table (LTyz) function blocks are not used by default, where yz can be 01 to 12.

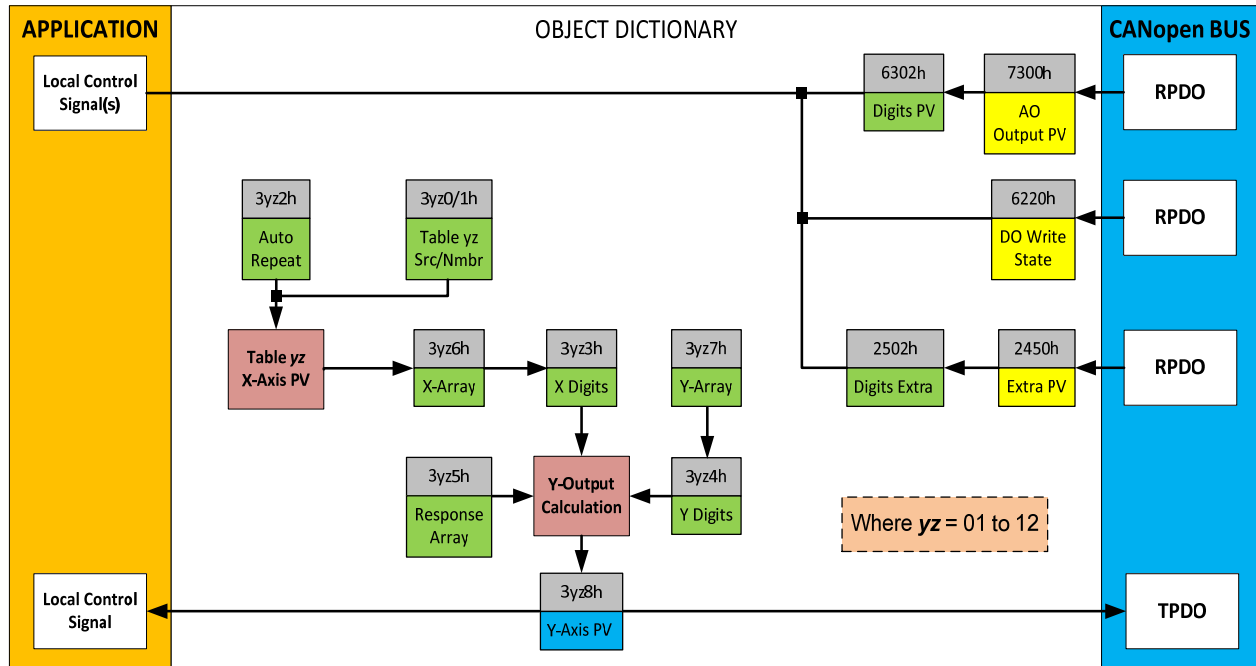

Figure 8 – Lookup Table Objects

Lookup tables are used to give an output response of up to 10 slopes per input. The array size of the objects 3yz5h **LTyz Point Response**, 3yz6h **LTyz Point X-Axis PV** and 3yz7h **Point Y-Axis PV** shown in the block diagram above is therefore 11.

Note: If more than 10 slopes are required, a Programmable Logic Block can be used to combine up to three tables to get 30 slopes, as is described in Section 1.6.

A parameter that will affect the function block is object 3yz5h **LTyz Point Response** sub-index 1 which defines the “**X-Axis Type**”. By default, the table have a ‘*Data Response*’ output (0). Alternatively, it can be selected as a ‘*Time Response*’ (1).

There are two (or three) other key parameters that will affect how this function block will behave depending on the “**X-Axis Type**” chosen. If chosen ‘*Data Response*’, then the objects 3yz0h **Lookup Table yz Input X-Axis Source** and 3yz1h **Lookup Table yz Input X-Axis Number** together define the control source for the function block. When it is changed, the table values in object 3yz6h and 3yz3h **LTyz X-Axis Decimal Digits PV** need to be updated with new defaults based on the X-Axis source selected as described in Tables 15 and 16. If however, the “**X-Axis Type**” is chosen to be ‘*Time Response*’, an additional parameter is taken into consideration - object 3yz2h, **Lookup Table yz Auto Repeat**. These will be described in more detail in Section 1.5.4.

1.5.1. X-Axis, Input Data Response

In the case where the “**X-Axis Type**” = ‘Data Response’, the points on the X-Axis represents the data of the control source.

However, should the minimum input be less than zero, for example a resistive input that is reflecting temperature in the range of -40°C to 210°C, then the object 3yz8h **LTyz Point X-Axis PV** sub-index 1 will be set to the minimum instead, in this case -40°C.

The constraint on the X-Axis data is that the next index value is greater than or equal to the one below it, as shown in the equation below. Therefore, when adjusting the X-Axis data, it is recommended that X₁₁ is changed first, then lower indexes in descending order.

$$\text{MinInputRange} \leq X_1 \leq X_2 \leq X_3 \leq X_4 \leq X_5 \leq X_6 \leq X_7 \leq X_8 \leq X_9 \leq X_{10} \leq X_{11} \leq \text{MaxInputRange}$$

As stated earlier, MinInputRange and MaxInputRange will be determined by the scaling objects associated with X-Axis Source that has been selected, as outlined in Table 15.

1.5.2. Y-Axis, Lookup Table Output

By default, it is assumed that the output from the lookup table function block will be a percentage value in the range of 0 to 100.

In fact, so long as all the data in the Y-Axis is $0 \leq Y[i] \leq 100$ (where $i = 1$ to 11) then other function blocks using the lookup table as a control source will have 0 and 100 as the Scaling 1 and Scaling 2 values used in linear calculations shown in Table 15.

However, the Y-Axis has no constraints on the data that it represents. This means that inverse, increasing/decreasing or other responses can be easily established. **The Y-Axis does not have to be a percentage output but could represent full scale process values instead.**

In all cases, the controller looks at the **entire range** of the data in the Y-Axis sub-indexes and selects the lowest value as the MinOutRange and the highest value as the MaxOutRange. So long as they are not both within the 0 to 100 range, they are passed directly to other function blocks as the limits on the lookup table output. (i.e. Scaling 1 and Scaling 2 values in linear calculations.)

Even if some of the data points are ‘*ignored*’ as described in Section 1.5.3, they are still used in the Y-Axis range determination. If not all the data points are going to be used, it is recommended that Y₁₀ be set to the minimum end of the range, and Y₁₁ to the maximum first. This way, the user can get predictable results when using the table to drive another function block.

1.5.3. Point to Point Response

By default, all six lookup tables have a simple linear response from 0 to 100 in steps of 10 for both the X and Y axes. For a smooth linear response, each point in the 3yz5h **LTyz Point Response** array is setup for a 'Ramp To' output.

Alternatively, the user could select a 'Step To' response for 3yz5h sub-index N, where N = 2 to 11. In this case, any input value between X_{N-1} to X_N will result in an output from the lookup table function block of Y_N . (Recall: *LTyz Point Response* sub-index 1 defines the X-Axis type)

Figure 9 shows the difference between these two response profiles with the default settings.

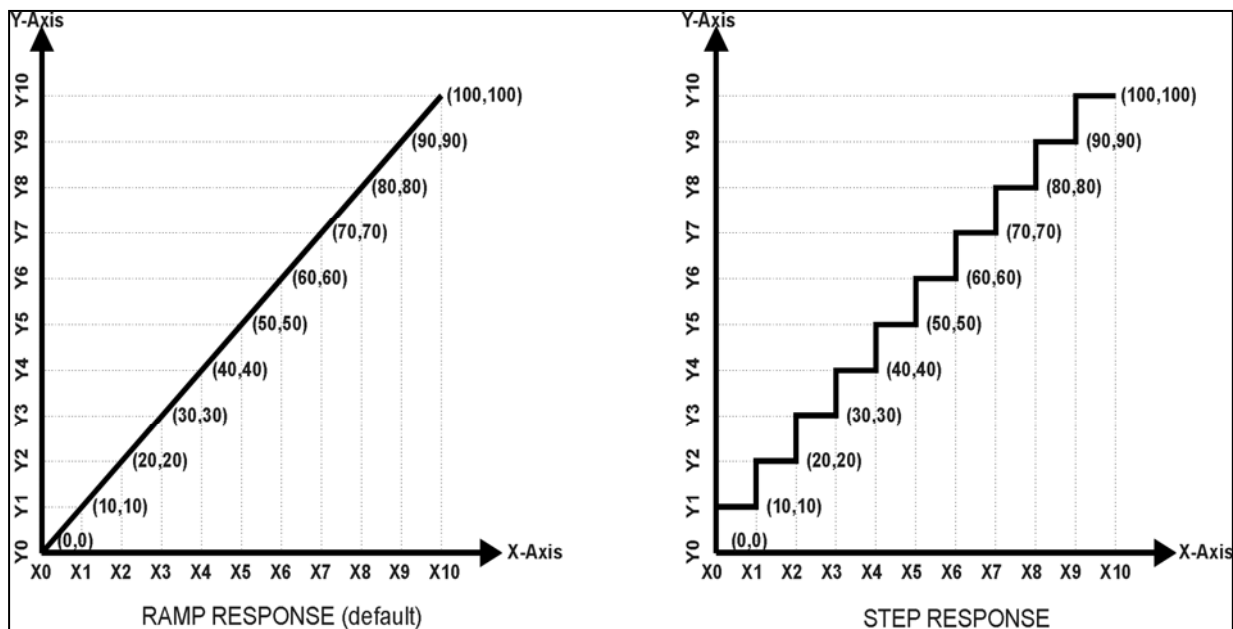

Figure 9 – Lookup Table Defaults with Ramp and Step Responses

Lastly, any point except (1,1) can be selected for an 'Ignore' response. If object 3yz5h **LTyz Point Response** sub-index N is set to *Ignore*, then all points from (X_N, Y_N) to (X_{11}, Y_{11}) will also be ignored. For all data greater than X_{N-1} , the output from the lookup table function block will be Y_{N-1} .

A combination of 'Ramp To', 'Jump To' and 'Ignore' responses can be used to create an application specific output profile. An example of where the same input is used as the X-Axis for two tables, but where the output profiles 'mirror' each other for a deadband joystick response is shown in Figure 10. The example shows a dual slope percentage output response for each side of the deadband, but additional slopes can be easily added as needed.

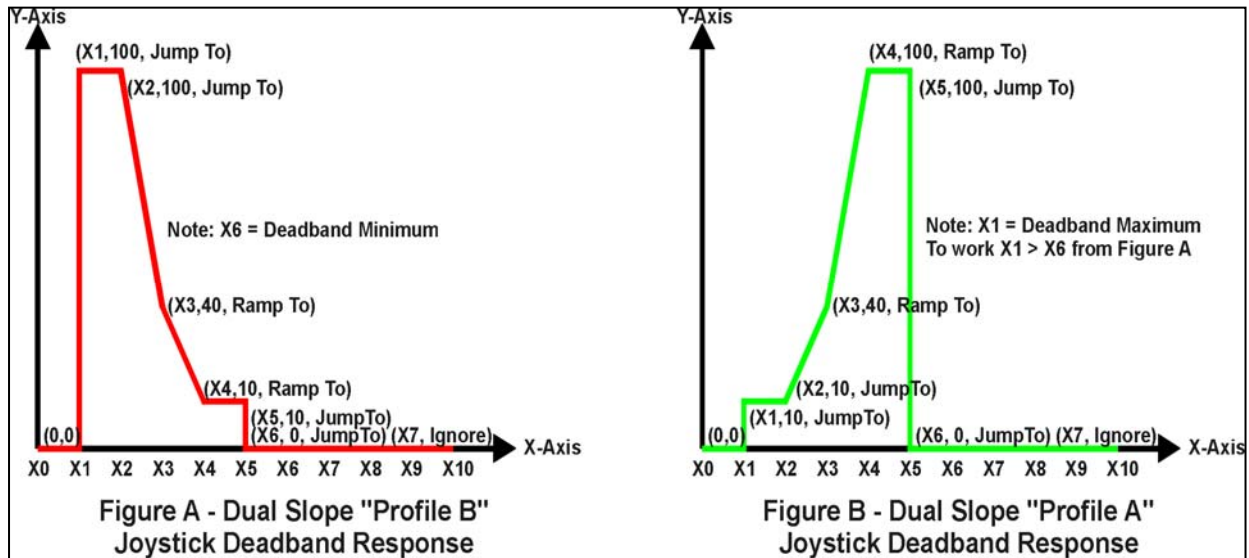

Figure 10 – Lookup Table Examples to Setup for Dual-Slope Joystick Deadband Response

To summarize, Table 16 outlines the different responses that can be selected for object 3yz4h, both for the X-Axis type and for each point in the table.

Sub-Index	Value	Meaning
1	0	Data Response (X-Axis Type)
2 to 11		Ignore (this point and all following it)
1	1	Time Response (X-Axis Type)
2 to 11		Ramp To (this point)
1	2	N/A (not an allowed option)
2 to 11		Jump To (this point)

Table 16 – LTyz Point Response Options

1.5.4. X-Axis, Time Response

As mentioned in Section 1.5.1, a lookup table can also be used to get a custom output response where the "X-Axis Type" is a 'Time Response'. When this is selected, the X-Axis now represents time, in units of milliseconds, while the Y-Axis still represents the output of the function block.

With this response, the sequence will start depending on two parameters:

- **Lookup Table yz Input X-Axis Source** Object 3yz0h and;
- **Lookup Table yz Auto Repeat** Object 3yz2h

By default, the “Auto Repeat” object is set to FALSE (0). In this case, the lookup table will react in the following way:

The X-Axis control source is treated as a digital input. When the control input is ON, the output will be changed over a period of time based on the profile in the lookup table. Once the profile has finished (i.e. reached index 11, or an ‘Ignored’ response), the output will remain at the last output at the end of the profile until the control input turns OFF.

However, when the “Auto Repeat” object is set to TRUE (1), the lookup table will react in the following way:

When the control input is ON, the output will be changed over a period of time based on the profile in the lookup table. Once the profile has finished (i.e. reached index 11, or an ‘Ignored’ response), the lookup table will revert back to the first point in the table and Auto Repeat the sequence. This will continue for as long as the input remains ON. Once the input turns OFF, the lookup table sequence will stop and the output of the lookup table is zero.

Note: When the control input is OFF, the output is always at zero. When the input comes ON, the profile will **ALWAYS** start at position (X₁, Y₁) which is 0 output for 0ms.

In a time response, the data in object 3yz8h **LTyz Point X-Axis PV** is measured in milliseconds, and object 3yz3h **LTyz X-Axis Decimal Digits PV** is automatically set to 0. A minimum value of 1ms must be selected for all points other than sub-index 1 which is automatically set to [0,0]. The interval time between each point on the X-axis can be set anywhere from 1ms to 24 hours. [86,400,000 ms]

1.6. Programmable Logic Function Block

The programmable logic blocks (LB(x-3)) functions are not used by default.

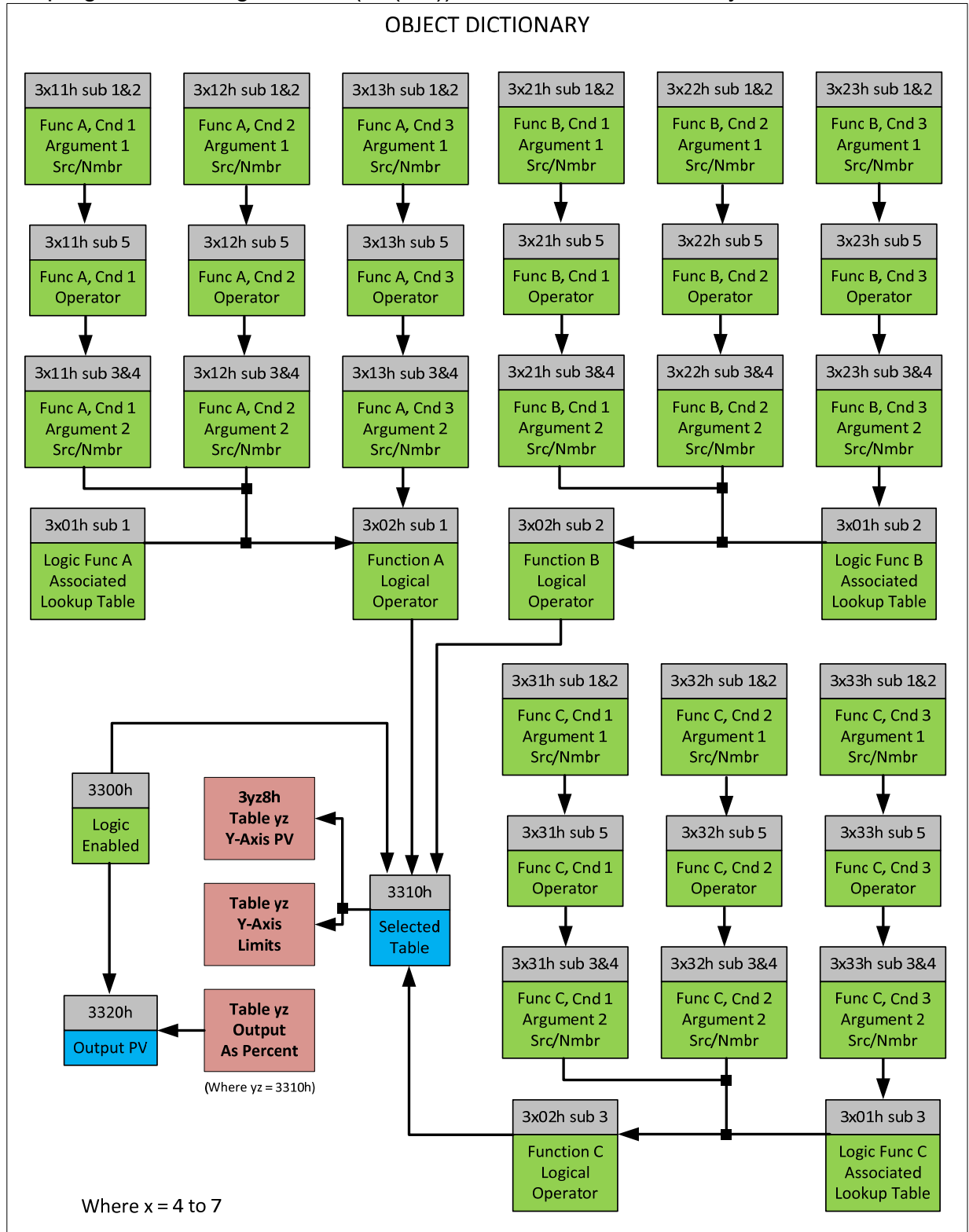

Figure 11 – Logic Block Objects

This function block is obviously the most complicated of them all, but very powerful. Any LB(x-3) (where X= 4 to 7) can be linked with up to three lookup tables, any one of which would be selected only under given conditions. Any three tables (of the available 12) can be associated with the logic, and which ones are used is fully configurable on object 3x01 **LB(x-3) Lookup Table Number**.

Should the conditions be such that a particular table (A, B or C) has been selected as described in Section 1.6.2, then the output from the selected table, at any given time, will be passed directly to LB(x-3)'s corresponding sub-index X in read-only mappable object 3320h **Logic Block Output PV**. The active table number can read from read-only object 3310h **Logic Block Selected Table**.

Note: In this document, the term *LB(x-3)* refers to Logic Blocks 1 to 4. Due to the CANopen® Object indices, Logic Block 1 begins at 3401h, where x, in this case, is 4.

Therefore, an LB(x-3) allows up to three different responses to the same input, or three different responses to different inputs, to become the control for another function block. Here, the “**Control Source**” for the reactive block would be selected to be the ‘*Programmable Logic Function Block,*’ as described in Section 1.4.

In order to enable any one of logic blocks, the corresponding sub-index in object 3300h **Logic Block Enable** must be set to TRUE. They are all disabled by default.

Logic is evaluated in the order shown in Figure 12. Only if a lower indexed table (A, B, C) has not been selected will the conditions for the next table be looked at. **The default table is always selected as soon as it is evaluated. It is therefore required that the default table always be the highest index in any configuration.**

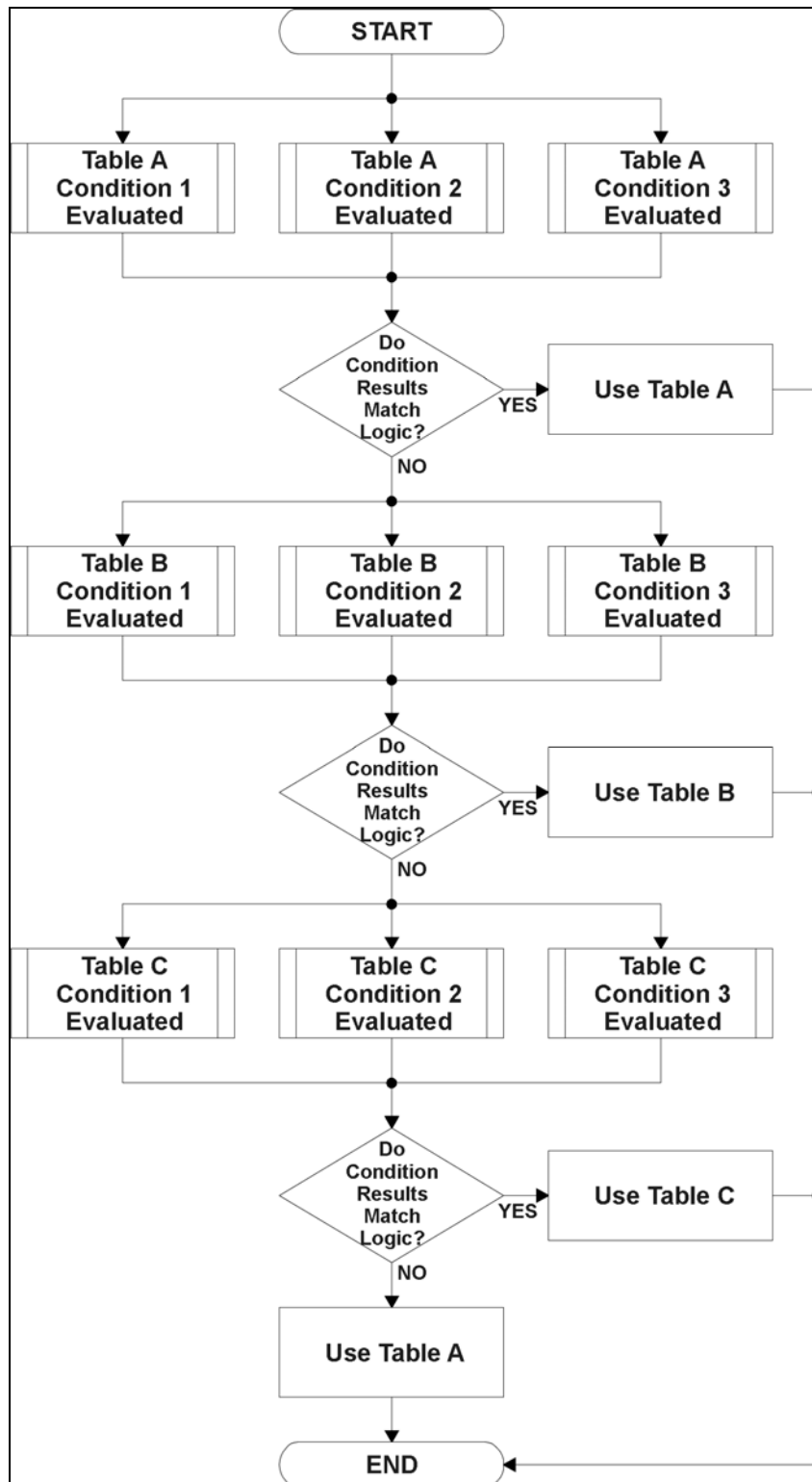

Figure 12 – Logic Block Flowchart

1.6.1. Conditions Evaluation

The first step in determining which table will be selected as the active table is to first evaluate the conditions associated with a given table. Each table has associated with it up to three conditions that can be evaluated. Conditional objects are custom DEFSTRUCT objects defined as shown in Table 17.

Index	Sub-Index	Name	Data Type
3xyz*	0	Highest sub-index supported	UNSIGNED8
	1	Argument 1 Source	UNSIGNED8
	2	Argument 1 Number	UNSIGNED8
	3	Argument 2 Source	UNSIGNED8
	4	Argument 2 Number	UNSIGNED8
	5	Operator	UNSIGNED8

* Logic Block X Function Y Condition Z, where X = 4 to 7, Y = A, B or C, and Z = 1 to 3

Table 17 – LB(x-3) Condition Structure Definition

Objects 3x11h, 3x12h and 3x13h are the conditions evaluated for selecting Table A. Objects 3x21h, 3x22h and 3x23h are the conditions evaluated for selecting Table B. Objects 3x31h, 3x32h and 3x33h are the conditions evaluated for selecting Table C.

Argument 1 is always a logical output from another function block, as listed in Table 13. As always, the input is a combination of the functional block objects 3xyzh sub-index 1 **“Argument 1 Source”** and **“Argument 1 Number.”**

Argument 2 on the other hand, could either be another logical output such as with Argument 1, OR a constant value set by the user. To use a constant as the second argument in the operation, set **“Argument 2 Source”** to *‘Constant Function Block’*, and **“Argument 2 Number”** to the desired sub-index. When defining the constant, make sure it uses the same resolution (decimal digits) as the Argument 1 input.

Argument 1 is evaluated against Argument 2 based on the **“Operator”** selected in sub-index 5 of the condition object. The options for the operator are listed in Table 18, and the default value is always *‘Equal’* for all condition objects.

Value	Meaning
0	=, Equal
1	!=, Not Equal
2	>, Greater Than
3	>=, Greater Than or Equal
4	<, Less Than
5	<=, Less Than or Equal

Table 18 – LB(x-3) Condition Operator Options

By default, both arguments are set to *'Control Source Not Used'* which disables the condition, and automatically results in a value of N/A as the result. Although it is generally considered that each condition will be evaluated as either TRUE or FALSE, the reality is that there could be four possible results, as described in Table 19.

Value	Meaning	Reason
0	False	(Argument 1) Operator (Argument 2) = False
1	True	(Argument 1) Operator (Argument 2) = True
2	Error	Argument 1 or 2 output was reported as being in an error state
3	Not Applicable	Argument 1 or 2 is not available (i.e. set to <i>'Control Source Not Used'</i>)

Table 19 – LB(x-3) Condition Evaluation Results

1.6.2. Table Selection

In order to determine if a particular table will be selected, logical operations are performed on the results of the conditions as determined by the logic in Section 1.6.1. There are several logical combinations that can be selected, as listed in Table 20. The default value for object 3x02h **LB(x-3) Function Logical Operator** is dependent on the sub-index. For sub-index 1 (Table A) and 2 (Table B), the *'Cnd1 And Cnd2 And Cnd3'* operator is used, whereas sub-index 3 (Table C) is setup as the *'Default Table'* response.

Value	Meaning
0	Default Table
1	Cnd1 And Cnd2 And Cnd3
2	Cnd1 Or Cnd2 Or Cnd3
3	(Cnd1 And Cnd2) Or Cnd3
4	(Cnd1 Or Cnd2) And Cnd3

Table 20 – LB(x-3) Function Logical Operator Options

Not every evaluation is going to need all three conditions. For example, check if the Engine RPM is below a certain value only has one condition listed. Therefore, it is important to understand how the logical operators would evaluate an Error or N/A result for a condition, as outlined in Table 21.

Logical Operator	Select Conditions Criteria
Default Table	Associated table is automatically selected as soon as it is evaluated.
Cnd1 And Cnd2 And Cnd3	<p>Should be used when two or three conditions are relevant, and all must be True to select the table.</p> <p>If any condition equals False or Error, the table is not selected. An N/A is treated like a True. If all three conditions are True (or N/A), the table is selected.</p> <p>If((Cnd1==True) &&(Cnd2==True)&&(Cnd3==True)) Then Use Table</p>
Cnd1 Or Cnd2 Or Cnd3	<p>Should be used when only one condition is relevant. Can also be used with two or three relevant conditions.</p> <p>If any condition is evaluated as True, the table is selected. Error or N/A results are treated as False</p> <p>If((Cnd1==True) (Cnd2==True) (Cnd3==True)) Then Use Table</p>
(Cnd1 And Cnd2) Or Cnd3	<p>To be used only when all three conditions are relevant.</p> <p>If both Condition 1 and Condition 2 are True, OR Condition 3 is True, the table is selected. Error or N/A results are treated as False</p> <p>If(((Cnd1==True)&&(Cnd2==True)) (Cnd3==True)) Then Use Table</p>
(Cnd1 Or Cnd2) And Cnd3	<p>To be used only when all three conditions are relevant.</p> <p>If Condition 1 And Condition 3 are True, OR Condition 2 And Condition 3 are True, the table is selected. Error or N/A results are treated as False</p> <p>If(((Cnd1==True) ((Cnd2==True)) && (Cnd3==True)) Then Use Table</p>

Table 21 – LB(x-3) Conditions Evaluation Based on Selected Logical Operator

If the result of the function logic is TRUE, then the associated lookup table (see object 3x01h) is immediately selected as the source for the logic output. No further conditions for other tables are evaluated. For this reason, the 'Default Table' should always be setup as the highest letter table being used (A, B or C) If no default response has been setup, the Table A automatically becomes the default when no conditions are true for any table to be selected. This scenario should be avoided whenever possible so as to not result in unpredictable output responses.

The table number that has been selected as the output source is written to sub-index X of read-only object 3310h **Logic Block Selected Table**. This will change as different conditions result in different tables being used.

1.6.3. Logic Block Output

Recall that Table Y, where Y = A, B or C in the LB(x-3) function block does NOT mean lookup table 1 to 3. Each table has object 3x01h LB(x-3) **Lookup Table Number** which allows the user to select which lookup tables they want associated with a particular logic block. The default tables associated with each logic block are listed in Table 22.

Programmable Logic Block Number	Table A – Lookup Table Block Number	Table B – Lookup Table Block Number	Table C – Lookup Table Block Number
1	1	2	3
2	4	5	6
3	7	8	9
4	10	11	12

Table 22 – LB(x-3) Default Lookup Tables

If the associated Lookup Table YZ (where YZ equals 3310h sub-index X) does not have an “**X-Axis Source**” selected, then the output of LB(x-3) will always be “Not Available” so long as that table is selected. However, should LTyz be configured for a valid response to an input, be it Data or Time, the output of the LTyz function block (i.e. the Y-Axis data that has been selected based on the X-Axis value) will become the output of the LB(x-3) function block so long as that table is selected.

The LB(x-3) output is always setup as a percentage, based on the range of the Y-Axis for the associated table (see Section 1.5.2) It is written to sub-index X of read-only object 3320h **Logic Block Output PV** with a resolution of 1 decimal place.

1.7. Math Function Block

There are six mathematic function blocks that allow the user to define basic algorithms. Math function block $y = 1$ to 6 will be enabled based on sub-index y in object 4000h **Math Enable**.

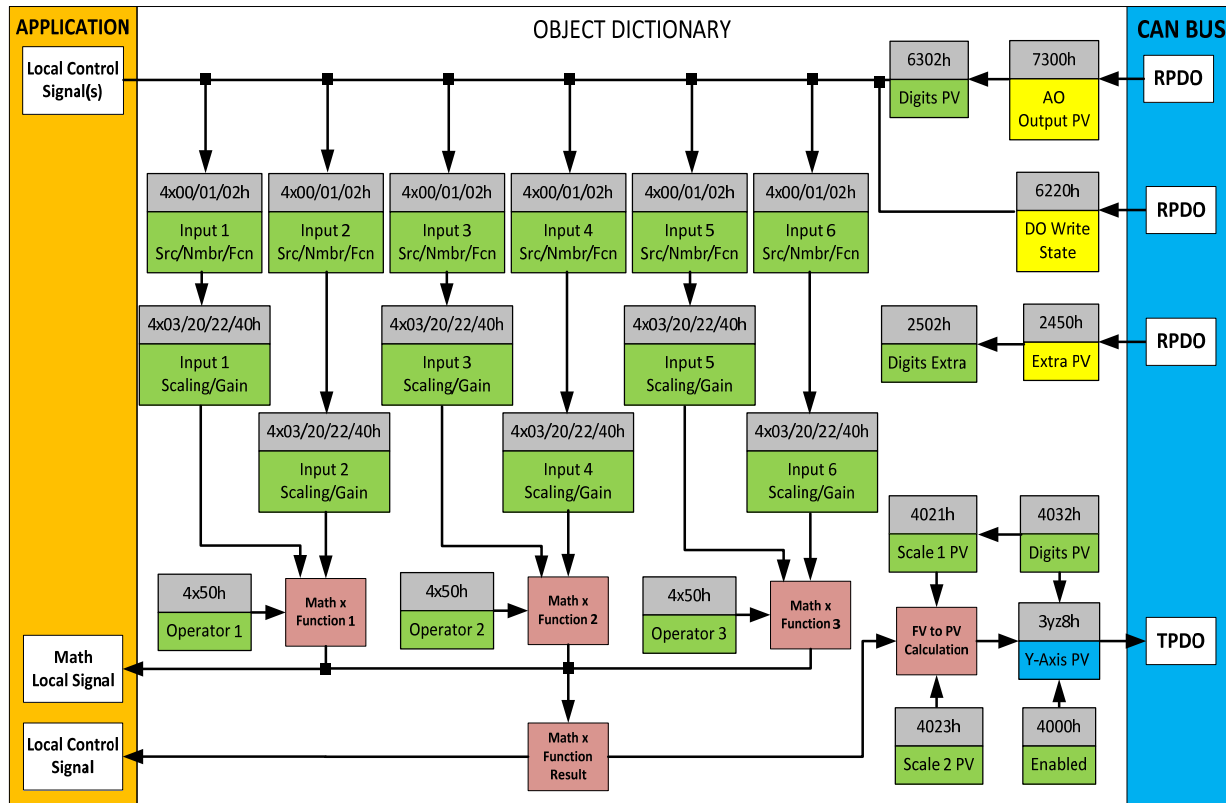

Figure 13 – Math Function Block Objects

A math function block can take up to six input signals, as listed in Table 13 in Section 1.4. Each input is then scaled according to the associated scaling and gain objects. A “Math Input X” is determined by the corresponding sub-index $X = 1$ to 6 of the objects 4y00h **Math Y Input Source** and 4y01h **Math Y Input Number**. Here, $y = 1$ to 6; corresponding to Math 1- Math 6.

Inputs are converted into a percentage value based on objects 4y20h **Math Y Scaling 1 FV** and 4y22h **Math Y Scaling 2 FV**. Before being used in the calculation, these objects apply the resolution shift defined by object 4y03h **Math Y Decimal Digits FV**. As with any other function block using a control source for the X-Axis in a conversion, the scaling objects should be selected to match the values in the control’s corresponding objects as per Table 15.

For additional flexibility, the user can also adjust object 4y40h **Math Y Input Gain**. This object has a fixed decimal digit resolution of 2, and a range of -100 to 100. By default, each input has a gain of 1.0.

For example, in the case where the user may want to combine two inputs such that a joystick (Input 1) is the primary control of an output, but the speed can be incremented or decremented based on a potentiometer (Input 2), it may be desired that 75% of the scale is controlled by the joystick position, while the potentiometer can increase or decrease the min/max output by up to 25%. In this case, Input 1 would have a gain of 0.75, while Input 2 uses 0.25. The resulting addition will give a command from 0 to 100% based on the combined positions of both inputs.

For each input pair, the appropriate arithmetic or logical operation is performed on the two inputs, InA and InB, according to the associated function in sub-index of InB in object 4y50h **Math Y Operator**. The list of selectable function operations is defined in Table 23.

0	=	True when InA Equals InB
1	!=	True when InA Not Equal InB
2	>	True when InA Greater Than InB
3	>=	True when InA Greater Than or Equal InB
4	<	True when InA Less Than InB
5	<=	True when InA Less Than or Equal InB
6	OR	True when InA or InB is True
7	NOR	True when InA and InB are False
8	AND	True when InA and InB are True
9	NAND	True when InA and InB are not both True
10	XOR	True when InA/InB is True, but not both
11	XNOR	True when InA and InB are both True or False
12	+	Result = InA plus InB
13	-	Result = InA minus InB
14	x	Result = InA times InB
15	/	Result = InA divided by InB
16	MIN	Result = Smallest of InA and InB
17	MAX	Result = Largest of InA and InB

Table 23 – Object 4y50h Math Function Operators

For Function 1, InA and InB are Math Inputs 1 and 2, respectively.

For Function 2, InA and InB are Math Inputs 3 and 4, respectively.

For Function 3, InA and InB are Math Inputs 5 and 6, respectively.

Exclusively **within** a Math Block, there is a third control parameter: Object 4y02h, **Math Y Function Number**. This parameter allows for the result of any Function (1, 2 or 3) to be the input to any **Math Input Y** within the same Math Block. Therefore, **Math Y Input Source** must be a Math Block and **Math Y Input Number** must be the same number as being configured. When these four parameters match, if **Math Y Function Number** is set to 1, 2, or 3, the respective input will be the result of the Function selected. By default, **Math Y Function Number** is set to 0 – in which case this parameter is ignored and uses the Math Block output result. These functions can only be used **within** the Math Block. They can not be used for other Math Blocks or logic blocks.

This allows for more versatility within the Math Block. For a valid result in each Function, both inputs must be non-zero value (other than '*Control Source Not Used*'). Otherwise, the corresponding Function is ignored. Furthermore, for a valid/expected output result in each Math Block, it is necessary to keep in mind how the Functions link to one another within the Math Block. As an example, consider all 6 inputs to be CANopen® Messages 1 to 6 (thus using all 3 Functions). Since all 3 functions are used but Function 3 has no relation to Function 1 or 2, the result of the Math Block will be the result of Function 3, thus, ignoring Functions 1 and 2.

For logical operators (6 to 11), any SCALED input greater than or equal to 0.5 is treated as a TRUE input. For logic output operators (0 to 11), the result of the calculation for the function will always be 0 (FALSE) or 1 (TRUE).

Error data (i.e. input measured out of range) is always treated as a 0.0 input into the function.

For the arithmetic functions (12 to 17), it is recommended to scale the data such that the resulting operation will not exceed full scale (0 to 100%) and saturate the output result.

When dividing, a zero InB value will always result in a zero output value for the associated function. When subtracting, a negative result will always be treated as a zero, unless the function is multiplied by a negative one, or the inputs are scaled with a negative coefficient first.

The resulting final mathematical output calculation is in the appropriate physical units using object 4021h **Math Output Scaling 1 PV** and 4023h **Math Output Scaling 2 PV**. These objects are also considered the Min and Max values of the Math Block output and apply the resolution shift defined by object 4032h **Math Output Decimal Digits PV**. The result is written to read-only object 4030h **Math Output PV**. These scaling objects should also be taken into account when the Math Function is selected as the input source for another function block, as outlined in Table 15.

1.8. Miscellaneous Function Block

There are some other objects available which have not yet been discussed or mentioned briefly in passing (i.e. constants.) These objects are not necessarily associated with one another but are all discussed here.

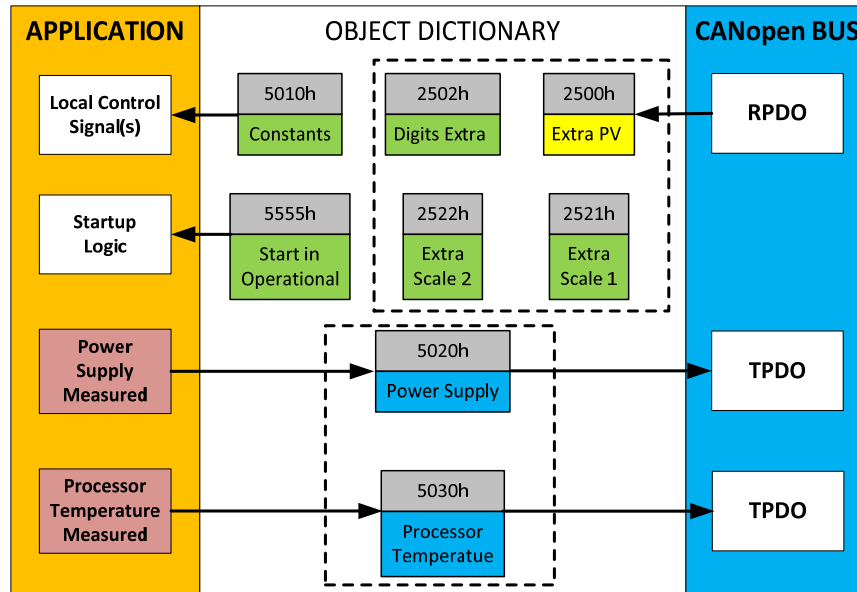

Figure 14 – Miscellaneous Objects

Extra RPDO Messages

Objects 2500h **Extra Control Received PV**, 2502h **EC Decimal Digits PV**, 2502h **EC Scaling 1 PV** and 2522h **EC Scaling 2 PV** have been mentioned in Section 1.4, Table 15. These objects allow for additional data received on a CANopen® RPDO to be mapped independently to various function blocks as a control source. The scaling objects are provided to define the limits of the data when it is used by another function block, as shown in Table 15.

Constant Values

Object 5010h **Constant Field Value** is provided to give the user the option for a fixed value that can be used by other function blocks. Sub-index 1 is fixed as FALSE (0) and sub-index 2 is always TRUE (1). There are 13 other sub-indexes provided for user selectable values.

The constants are read as 32-bit real (float) data, so no decimal digit object is provided. When setting up the constant, make sure to do it with the resolution of the object that will be compared with it.

The False/True constants are provided primarily to be used with the logic block. The variable constants are also useful with the logic or math blocks.

Automatic Update of Objects

Object 5550h **Enable Automatic Updates** allows for the controller to automatically update the objects related to the output to defaults when it is changed. By default, this object is set to TRUE, in which case the objects are set to their default values depending on the type selected.

On the other hand, when this object is FALSE, the objects are not set to defaults and are left with the same values previous to changing the type. In this case, these are to be configured manually.

Startup

The last object 5555h **Start in Operational** is provided as a 'cheat' when the unit is not intended to work with a CANopen® network (i.e. a stand-alone control), or is working on a network comprised solely as slaves so the OPERATION command will never be received from a master. By default, this object is disabled (FALSE).

When using the Data Logger as a stand-alone controller where 5555h is set to TRUE, it is recommended to disable all TPDOs (set the Event Timer to zero) so that it does not run with a continuous CAN error when not connected to a bus.

2. INSTALLING INSTRUCTIONS

2.1. Dimensions and Pinout

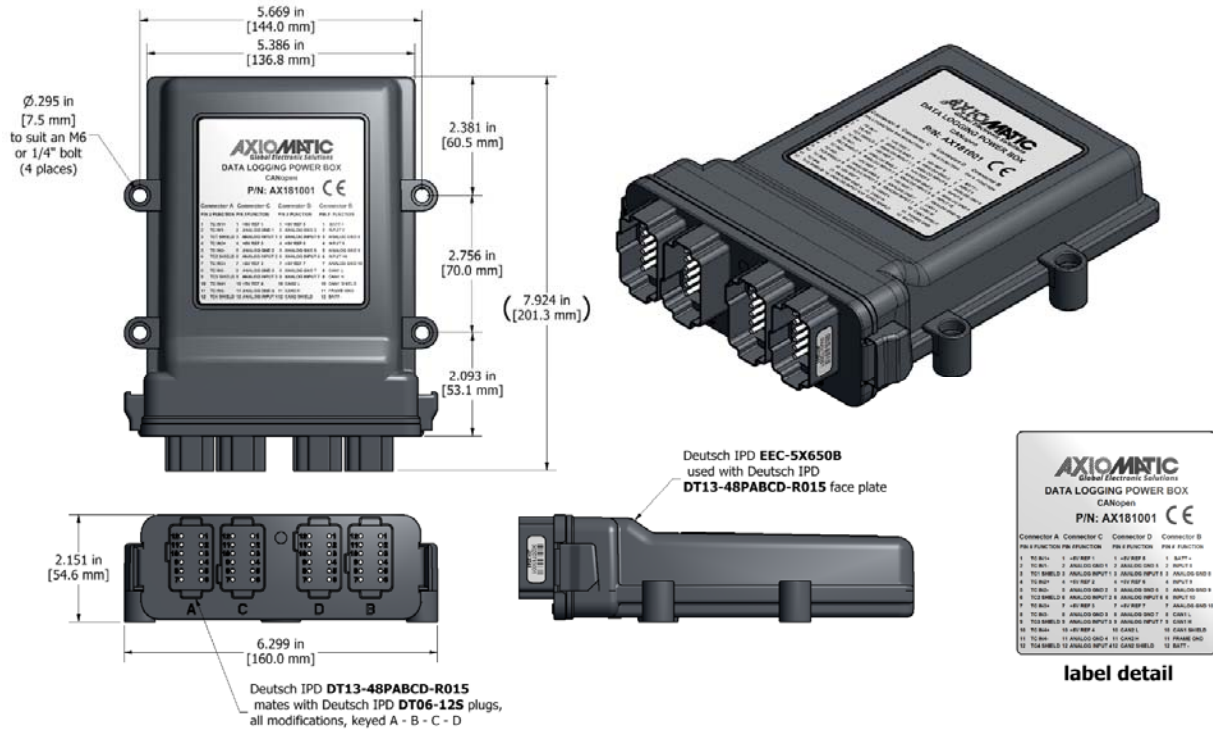

Figure 15 – Housing Dimensions

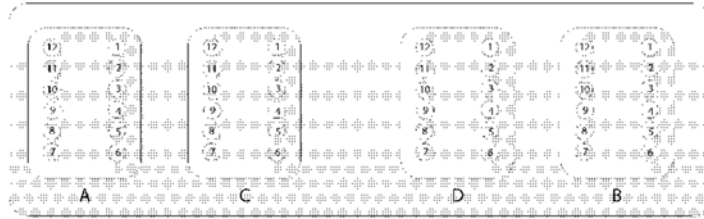

Table 3.0 - Electrical Pin Out

Connector A		Connector C		Connector D		Connector B	
Pin #	Function	Pin #	Function	Pin #	Function	Pin #	Function
1	TC IN1+	1	+5Vref. 1	1	+5Vref. 5	1	Batt+
2	TC IN1-	2	Analog GND 1	2	Analog GND 5	2	Input 8
3	TC1 Shield	3	Analog Input 1	3	Analog Input 5	3	Analog GND 8
4	TC IN2+	4	+5Vref. 2	4	+5Vref. 6	4	Input 9
5	TC IN2-	5	Analog GND 2	5	Analog GND 6	5	Analog GND 9
6	TC2 Shield	6	Analog Input 2	6	Analog Input 6	6	Input 10
7	TC IN3+	7	+5Vref. 3	7	+5Vref. 7	7	Analog GND 10
8	TC IN3-	8	Analog GND 3	8	Analog GND 7	8	CAN1 L
9	TC3 Shield	9	Analog Input 3	9	Analog Input 7	9	CAN1 H
10	TC IN4+	10	+5Vref. 4	10	CAN2 L	10	CAN1 Shield
11	TC IN4-	11	Analog GND 4	11	CAN2 H	11	Frame GND
12	TC4 Shield	12	Analog Input 4	12	CAN2 Shield	12	Batt-

Table 24 – Connector Pinout

2.2. Installation Instructions

MOUNTING

For mounting information, refer to the dimensional drawing.

Mounting holes sized for ¼ inch or M6 bolts. The bolt length will be determined by the end-user's mounting plate thickness. The mounting flange of the controller is 0.25 inches (6.35 mm) thick. If the module is mounted without an enclosure, it should be mounted to reduce the likelihood of moisture entry. Install the unit with appropriate space available for servicing and for adequate wire harness access (6 inches or 15 cm) and strain relief (12 inches or 30 cm). Wires should be of the appropriate gauge to meet requirements of applicable electrical codes and suit the specifications of the connector.

The module must be mounted in an enclosure in hazardous locations. All field wiring should be suitable for the operating temperature range of the module. All chassis grounding should go to a single ground point designated for the machine and all related equipment.

NETWORK TERMINATION

It is necessary to terminate the network with external termination resistors. The resistors are 120 Ohm, 0.25W minimum, metal film or similar type. They should be placed between CAN_H and CAN_L terminals at both ends of the network.

3. CANOPEN® OBJECT DICTIONARY

The CANopen® object dictionary of Data Logger is based on CiA device profile DS-404 V1.2 (device profile for Closed Loop Controllers). The object dictionary includes Communication Objects beyond the minimum requirements in the profile, as well as several manufacturer-specific objects for extended functionality. The Data Logger supports 2 CAN interfaces which share manufacturer-specific objects but have separate Communication Objects.

3.1. NODE ID and BAUDRATE

By default, the controller ships factory programmed with a Node ID = 127 (0x7F) and with Baudrate = 125 kbps.

3.1.1. LSS Protocol to Update

The only means by which the Node-ID and Baudrate can be changed is to use Layer Settling Services (LSS) and protocols as defined by CANopen® standard DS-305.

Follow the steps below to configure either variable using LSS protocol. If required, please refer to the standard for more detailed information about how to use the protocol.

3.1.1.1. Setting Node-ID

- Set the module state to LSS-configuration by **sending** the following message:

<i>Item</i>	<i>Value</i>
COB-ID	0x7E5
Length	2
Data 0	0x04 (cs=4 for switch state global)
Data 1	0x01 (switches to configuration state)

- Set the Node-ID by **sending** the following message:

<i>Item</i>	<i>Value</i>
COB-ID	0x7E5
Length	2
Data 0	0x11 (cs=17 for configure node-id)
Data 1	Node-ID (set new Node-ID as a hexadecimal number)

- The module will send the following response (any other response is a failure).

<i>Item</i>	<i>Value</i>
COB-ID	0x7E4
Length	3
Data 0	0x11 (cs=17 for configure node-id)
Data 1	0x00
Data 2	0x00

- Save the configuration by **sending** the following message:

<i>Item</i>	<i>Value</i>
COB-ID	0x7E5
Length	1
Data 0	0x17 (cs=23 for store configuration)

- The module will send the following response (any other response is a failure):

<i>Item</i>	<i>Value</i>
COB-ID	0x7E4
Length	3
Data 0	0x17 (cs=23 for store configuration)
Data 1	0x00
Data 2	0x00

- Set the module state to LSS-operation by **sending** the following message:
(Note, the module will reset itself back to the pre-operational state)

<i>Item</i>	<i>Value</i>
COB-ID	0x7E5
Length	2
Data 0	0x04 (cs=4 for switch state global)
Data 1	0x00 (switches to waiting state)

3.1.1.2. Setting Baudrate

- Set the module state to LSS-configuration by **sending** the following message:

<i>Item</i>	<i>Value</i>
COB-ID	0x7E5
Length	2
Data 0	0x04 (cs=4 for switch state global)
Data 1	0x01 (switches to configuration state)

- Set the baudrate by **sending** the following message:

<i>Item</i>	<i>Value</i>
COB-ID	0x7E5
Length	3
Data 0	0x13 (cs=19 for configure bit timing parameters)
Data 1	0x00 (switches to waiting state)
Data 2	Index (select baudrate index per Table 25)

<i>Index</i>	<i>Bit Rate</i>
0	1 Mbit/s
1	800 kbit/s
2	500 kbit/s
3	250 kbit/s
4	125 kbit/s (default)
5	reserved (100 kbit/s)
6	50 kbit/s
7	20 kbit/s
8	10 kbit/s

Table 25 – LSS Baudrate Indices

- The module will send the following response (any other response is a failure):

<i>Item</i>	<i>Value</i>
COB-ID	0x7E4
Length	3
Data 0	0x13 (cs=19 for configure bit timing parameters)
Data 1	0x00
Data 2	0x00

- Activate bit timing parameters by **sending** the following message:

<i>Item</i>	<i>Value</i>
COB-ID	0x7E5
Length	3
Data 0	0x15 (cs=19 for activate bit timing parameters)
Data 1	<delay_lsb>
Data 2	<delay_msb>

The delay individually defines the duration of the two periods of time to wait until the bit timing parameters switch is done (first period) and before transmitting any CAN message with the new bit timing parameters after performing the switch (second period). The time unit of switch delay is 1 ms.

- Save the configuration by **sending** the following message (on the NEW baudrate):

<i>Item</i>	<i>Value</i>
COB-ID	0x7E5
Length	1
Data 0	0x17 (cs=23 for store configuration)

- The module will send the following response (any other response is a failure):

<i>Item</i>	<i>Value</i>
COB-ID	0x7E4
Length	3
Data 0	0x17 (cs=23 for store configuration)
Data 1	0x00
Data 2	0x00

- Set the module state to LSS-operation by **sending** the following message:
(Note, the module will reset itself back to the pre-operational state)

<i>Item</i>	<i>Value</i>
COB-ID	0x7E5
Length	2
Data 0	0x04 (cs=4 for switch state global)
Data 1	0x00 (switches to waiting state)

The following screen capture (left) shows the CAN data was sent (7E5h) and received (7E4h) by the tool when the baudrate was changed to 250 kbps using the LSS protocol. The other image (right) shows what was printed on an example debug RS-232 menu while the operation took place.

Between CAN Frame 98 and 99, the baudrate on the CAN Scope tool was changed from 125 to 250 kbps.

The left screenshot shows the CANscope interface. At the top, it says 'Net0 | CAN USB331 | 250 - CANscope'. Below that is a menu bar with 'File', 'Can', and 'Help'. There is an 'Add/Delete ID Area' section with 'from' and 'to' fields, an 'Add >' button, a '0x000 <> 0x7FF' text box, a '< Del' button, and a 'Net: 0 - CAN_USB331' label. Below this is a 'Baud rate: 250' dropdown menu. A table of frames is visible:

Frame...	Absolute Time	RelTime	Id	Atr	L	d1	d2	d3	d4
95	11:42:45.248	6110	07E5		2	04	01		
96	11:42:54.468	9219	07E5		3	13	00	03	
97	11:42:54.468	0	07E4		3	13	00	00	
98	11:42:58.687	4218	07E5		3	15	88	13	
99	11:43:16.579	17891	07E5		1	17			
100	11:43:16.907	328	07E4		3	17	00	00	
101	11:43:23.017	6109	07E5		2	04	00		
102	11:43:23.017	0	0750		1	00			

At the bottom of the window, there is a 'Send' button, an 'ID:' field, and checkboxes for '29-Bit', 'RTR', 'Len:', and 'Data\$'. The status bar at the bottom shows 'Fill:102(10.2%)', 'Bus:ok', and 'STARTED'.

The right screenshot shows a terminal window with a menu and status messages. The menu is as follows:

```

===== Main Menu =====
Choose one of the following:
U: View Object Dictionary
D: Default Object Dictionary
T: Toggle RS-232 Stream On/Off
S: Show/Stop Diagnostics
L: Load New Software
M: Main Menu (this)

->Node Id = 80
->Baudrate= 125 [kbps]
CO: PRE-OPERATIONAL
Activating new baud = 250 [kbps]
CO: STOP
Restarting CAN in 5000 [ms]
CO: PRE-OPERATIONAL
Storing ID
Storing Factory Parameters

Storing Baud
Storing Factory Parameters

Storing Communication Parameters

->Node Id = 80
->Baudrate= 250 [kbps]
CO: PRE-OPERATIONAL
  
```

3.2. COMMUNICATION OBJECTS (DS-301 and DS-404)

The communication objects supported by this controller are listed in the following table. A more detailed description of some of the objects is given in the following subchapters. Only those objects that have device-profile specific information are described. For more information on the other objects, refer to the generic CANopen® protocol specification DS-301.

Index (hex)	Object	Object Type	Data Type	Access	PDO Mapping
1000	Device Type	VAR	UNSIGNED32	RO	No
1001	Error Register	VAR	UNSIGNED8	RO	No
1002	Manufacturer Status Register	VAR	UNSIGNED32	RO	No
1003	Pre-Defined Error Field	ARRAY	UNSIGNED32	RO	No
100C	Guard Time	VAR	UNSIGNED16	RW	No
100D	Life Time Factor	VAR	UNSIGNED8	RW	No
1010	Store Parameters	ARRAY	UNSIGNED32	RW	No
1011	Restore Default Parameters	ARRAY	UNSIGNED32	RW	No
1016	Consumer Heartbeat Time	ARRAY	UNSIGNED32	RW	No
1017	Producer Heartbeat Time	VAR	UNSIGNED16	RW	No
1018	Identity Object	RECORD		RO	No
1020	Verify Configuration	ARRAY	UNSIGNED32	RO	No
1029	Error Behaviour	ARRAY	UNSIGNED8	RW	No
1400	RPDO1 Communication Parameter	RECORD		RW	No
1401	RPDO2 Communication Parameter	RECORD		RW	No
1402	RPDO3 Communication Parameter	RECORD		RW	No
1403	RPDO4 Communication Parameter	RECORD		RW	No
1404	RPDO5 Communication Parameter	RECORD		RW	No
1405	RPDO6 Communication Parameter	RECORD		RW	No
1406	RPDO7 Communication Parameter	RECORD		RW	No
1600	RPDO1 Mapping Parameter	RECORD		RO	No
1601	RPDO2 Mapping Parameter	RECORD		RO	No
1602	RPDO3 Mapping Parameter	RECORD		RO	No
1603	RPDO4 Mapping Parameter	RECORD		RO	No
1604	RPDO5 Mapping Parameter	RECORD		RO	No
1605	RPDO6 Mapping Parameter	RECORD		RO	No
1606	RPDO7 Mapping Parameter	RECORD		RO	No
1800	TPDO1 Communication Parameter	RECORD		RW	No
1801	TPDO2 Communication Parameter	RECORD		RW	No

1802	TPDO3 Communication Parameter	RECORD		RW	No
1803	TPDO4 Communication Parameter	RECORD		RW	No
1804	TPDO5 Communication Parameter	RECORD		RW	No
1805	TPDO6 Communication Parameter	RECORD		RW	No
1806	TPDO7 Communication Parameter	RECORD		RW	No
1A00	TPDO1 Mapping Parameter	RECORD		RW	No
1A01	TPDO2 Mapping Parameter	RECORD		RW	No
1A02	TPDO3 Mapping Parameter	RECORD		RW	No
1A03	TPDO4 Mapping Parameter	RECORD		RW	No
1A04	TPDO5 Mapping Parameter	RECORD		RW	No
1A05	TPDO6 Mapping Parameter	RECORD		RW	No
1A06	TPDO7 Mapping Parameter	RECORD		RW	No

3.2.1. Object 1000h: Device Type

This object contains information about the device type as per device profile DS-404. The 32-bit parameter is divided into two 16-bit values, showing General and Additional information as shown below.

MSB	LSB
Additional Information = 0xE003	General Information = 0x0194 (404)

DS-404 defines the Additional Information field in the following manner:

- 0000h = reserved
- 0001h = digital input block
- 0002h = analog input block
- 0004h = digital output block
- 0008h = analog output block
- 0020h = alarm block
- 0040h ... 0800h = reserved
- 1000h = reserved
- 2000h = lookup table block (manufacturer-specific)
- 4000h = programmable logic block (manufacturer-specific)
- 8000h = miscellaneous block (manufacturer-specific)

Object Description

Index	1000h
Name	Device Type
Object Type	VAR
Data Type	UNSIGNED32

Entry Description

Access	RO
PDO Mapping	No
Value Range	0xE0030194
Default Value	0xE0030194

3.2.2. Object 1001h: Error Register

This object is an error register for the device. Any time there is an error detected by the Data Logger, the Generic Error Bit (bit 0) is set. Only if there is no error in the module, this bit will be cleared. No other bits in this register are used by the controller.

Object Description

Index	1001h
Name	Error Register
Object Type	VAR
Data Type	UNSIGNED8

Entry Description

Access	RO
PDO Mapping	No
Value Range	00h or 01h
Default Value	0

3.2.3. Object 1002h: Manufacturer Status Register

This object is used for manufacturer debug purposes.

3.2.4. Object 1003h: Pre-Defined Error Field

This object provides an error history by listing the errors in the order that they have occurred. An error is added to the top of the list when it occurs and is immediately removed when the error condition has been cleared. The latest error is always at sub-index 1, with sub-index 0 containing the number of errors currently in the list. When the device is in an error-free state, the value of sub-index 0 is zero.

The error list may be cleared by writing a zero to sub-index 0, which will clear all errors from the list, regardless of whether or not they are still present. Clearing the list does NOT mean that the module will return to the error-free behavior state if at least one error is still active.

The controller has a limitation of a maximum of 4 errors in the list. If the device registers more errors, the list will be truncated, and the oldest entries will be lost.

The error codes stored in the list are 32-bit unsigned numbers, consisting of two 16-bit fields. The lower 16-bit field is the EMCY error code, and the higher 16-bit field is a manufacturer-specific code. The manufacturer-specific code is divided into two 8-bit fields, with the higher byte indicating the error description, and the lower byte indicating the channel on which the error occurred.

MSB		LSB
Error Description	Channel-ID	EMCY Error Code

If node-guarding is used (not recommended per the latest standard) and a lifeguard event occurs, the manufacturer-specific field will be set to 0x1000. On the other hand, if a heartbeat consumer fails to be received within the expected timeframe, the Error Description will be set to 0x80 and the Channel-ID (nn) will reflect the Node-ID of the consumer channel that was not producing. In this case, the manufacturer-specific field will therefore be 0x80nn. In both cases, the corresponding EMCY Error Code will be the Guard Error 0x8130.

When an analog input/thermocouple is not working as described in the previous sections, then the Error Description will reflect what channel(s) is at fault using the following table. Also, if an RPDO is not received within the expected “Event Timer” period, an RPDO timeout will be flagged. Table 26 outlines the resulting Error Field Codes and their meanings.

Error Field Code	Error Description	Meaning	ID	Meaning	EMCY Code	Meaning
00000000h	EMCY Error Reset (fault no longer active)					
2001F001h	20h	AI Positive Overload (Out of Range High)	01h	Analog Input 1	F001h	Input Overload
4001F001h	40h	Negative Overload (Out of Range Low)	01h	Analog Input 1	F001h	Input Overload
2002F001h	20h	AI Positive Overload	02h	Analog Input 2	F001h	Input Overload
4002F001h	40h	AI Negative Overload	02h	Analog Input 2	F001h	Input Overload
2003F001h	20h	AI Positive Overload	03h	Analog Input 3	F001h	Input Overload
4003F001h	40h	AI Negative Overload	03h	Analog Input 3	F001h	Input Overload
2004F001h	20h	AI Positive Overload	04h	Analog Input 4	F001h	Input Overload
4004F001h	40h	AI Negative Overload	04h	Analog Input 4	F001h	Input Overload
2005F001h	20h	AI Positive Overload	05h	Analog Input 5	F001h	Input Overload
4005F001h	40h	AI Negative Overload	05h	Analog Input 5	F001h	Input Overload
2006F001h	20h	AI Positive Overload	06h	Analog Input 6	F001h	Input Overload
4006F001h	40h	AI Negative Overload	06h	Analog Input 6	F001h	Input Overload
2007F001h	20h	AI Positive Overload	07h	Analog Input 7	F001h	Input Overload
4007F001h	40h	AI Negative Overload	07h	Analog Input 7	F001h	Input Overload
2008F001h	20h	AI Positive Overload	08h	Analog Input 8	F001h	Input Overload
4008F001h	40h	AI Negative Overload	08h	Analog Input 8	F001h	Input Overload
2009F001h	20h	AI Positive Overload	09h	Analog Input 9	F001h	Input Overload
4009F001h	40h	AI Negative Overload	09h	Analog Input 9	F001h	Input Overload
200AF001h	20h	AI Positive Overload	0Ah	Analog Input 10	F001h	Input Overload
400AF001h	40h	AI Negative Overload	0Ah	Analog Input 10	F001h	Input Overload
0110F011h	01h	TC Low Warning Limit Exceeded	10h	Thermocouple 1	F011h	TC Limit Exceeded
0210F011h	02h	TC High Warning Limit Exceeded	10h	Thermocouple 1	F011h	TC Limit Exceeded

0410F011h	04h	TC Low Shutdown Limit Exceeded	10h	Thermocouple 1	F011h	TC Limit Exceeded
0810F011h	08h	TC High Shutdown Limit Exceeded	10h	Thermocouple 1	F011h	TC Limit Exceeded
1010F002h	10h	TC Overload (Open Circuit)	10h	Thermocouple 1	F002h	Thermocouple Overload
0120F011h	01h	TC Low Warning Limit Exceeded	20h	Thermocouple 2	F011h	TC Limit Exceeded
0220F011h	02h	TC High Warning Limit Exceeded	20h	Thermocouple 2	F011h	TC Limit Exceeded
0420F011h	04h	TC Low Shutdown Limit Exceeded	20h	Thermocouple 2	F011h	TC Limit Exceeded
0820F011h	08h	TC High Shutdown Limit Exceeded	20h	Thermocouple 2	F011h	TC Limit Exceeded
1020F002h	10h	TC Overload (Open Circuit)	20h	Thermocouple 2	F002h	Thermocouple Overload
0130F011h	01h	TC Low Warning Limit Exceeded	30h	Thermocouple 3	F011h	TC Limit Exceeded
0230F011h	02h	TC High Warning Limit Exceeded	30h	Thermocouple 3	F011h	TC Limit Exceeded
0430F011h	04h	TC Low Shutdown Limit Exceeded	30h	Thermocouple 3	F011h	TC Limit Exceeded
0830F011h	08h	TC High Shutdown Limit Exceeded	30h	Thermocouple 3	F011h	TC Limit Exceeded
1030F002h	10h	TC Overload (Open Circuit)	30h	Thermocouple 3	F002h	Thermocouple Overload
0140F011h	01h	TC Low Warning Limit Exceeded	40h	Thermocouple 4	F011h	TC Limit Exceeded
0240F011h	02h	TC High Warning Limit Exceeded	40h	Thermocouple 4	F011h	TC Limit Exceeded
0440F011h	04h	TC Low Shutdown Limit Exceeded	40h	Thermocouple 4	F011h	TC Limit Exceeded
0840F011h	08h	TC High Shutdown Limit Exceeded	40h	Thermocouple 4	F011h	TC Limit Exceeded
1040F002h	10h	TC Overload (Open Circuit)	40h	Thermocouple 4	F002h	Thermocouple Overload
20003000h	20h	Positive Overload (Vps Overvoltage)	00h	Unspecified	3000h	Generic Voltage
40003000h	40h	Negative Overload (Vps Undervoltage)	00h	Unspecified	3000h	Generic Voltage
00008100h	00h	RPDO Timeout	00h	Unspecified	8100h	Communication - generic
10008130h	10h	Lifeguard Event	00h	Unspecified	8130h	Lifeguard/Heartbeat Error
80nn8130h	80h	Heartbeat Timeout	nn	Node-ID	8130h	Lifeguard/Heartbeat Error
00008140h	00h	Bus OFF Event	00h	Unspecified	8400h	Bus OFF Recovery

Table 26 – Pre-Defined Error Field Codes

Object Description

Index	1003h
Name	Pre-Defined Error Field
Object Type	ARRAY
Data Type	UNSIGNED32

Entry Description

Sub-Index	0h
Description	Number of entries
Access	RW
PDO Mapping	No
Value Range	0 to 5
Default Value	0

Sub-Index	1h to 5h
Description	Standard error field
Access	RO
PDO Mapping	No
Value Range	UNSIGNED32
Default Value	0

3.2.5. Object 100Ch: Guard Time

The objects at index 100Ch and 100Dh shall indicate the configured guard time respective to the life time factor. The life time factor multiplied with the guard time gives the life time for the life guarding protocol described in DS-301. The Guard Time value shall be given in multiples of ms, and a value of 0000h shall disable the life guarding.

It should be noted that this object, and that of 100Dh are only supported for backwards compatibility. The standard recommends that newer networks do not use the life guarding protocol, but rather heartbeat monitoring instead. Both life guarding and heartbeats can NOT be active simultaneously.

Object Description

Index	100Ch
Name	Guard Time
Object Type	VAR
Data Type	UNSIGNED16

Entry Description

Sub-Index	0h
Access	RW
PDO Mapping	No
Value Range	0 to 65535
Default Value	0

3.2.6. Object 100Dh: Life Time Factor

The life time factor multiplied with the guard time gives the life time for the life guarding protocol. A value of 00h shall disable life guarding.

Object Description

Index	100Dh
Name	Life Time Factor
Object Type	VAR
Data Type	UNSIGNED8

Entry Description

Sub-Index	0h
Access	RW
PDO Mapping	No
Value Range	0 to 255
Default Value	0

3.2.7. Object 1010h: Store Parameters

This object supports the saving of parameters in non-volatile memory. In order to avoid storage of parameters by mistake, storage is only executed when a specific signature is written to the appropriate sub-index. The signature is “save”. The “save” action on either CAN buses will apply to the parameters on both buses.

The signature is a 32-bit unsigned number, composed of the ASCII codes of the signature characters, according to the following table:

MSB		LSB	
e	v	a	s
65h	76h	61h	73h

On reception of the correct signature to an appropriate sub-index, the controller will store the parameters in non-volatile memory, and then confirm the SDO transmission.

By read access, the object provides information about the module’s saving capabilities. For all sub-indexes, this value is 1h, indicating that the controller saves parameters on command. **This means that if power is removed before the Store object is written, changes to the Object Dictionary will NOT have been saved in the non-volatile memory and will be lost on the next power cycle.**

Object Description

Index	1010h
Name	Store Parameters
Object Type	ARRAY
Data Type	UNSIGNED32

Entry Description

Sub-Index	0h
Description	Largest sub-index supported
Access	RO
PDO Mapping	No
Value Range	4
Default Value	4

Sub-Index	1h
Description	Save all parameters
Access	RW
PDO Mapping	No
Value Range	0x65766173 (write access) 1h (read access)
Default Value	1h

Sub-Index	2h
Description	Save communication parameters
Access	RW
PDO Mapping	No
Value Range	0x65766173 (write access) 1h (read access)
Default Value	1h

Sub-Index	3h
Description	Save application parameters
Access	RW
PDO Mapping	No
Value Range	0x65766173 (write access) 1h (read access)
Default Value	1h

Sub-Index	4h
Description	Save manufacturer parameters
Access	RW
PDO Mapping	No
Value Range	0x65766173 (write access) 1h (read access)
Default Value	1h

3.2.8. Object 1011h: Restore Parameters

This object supports the restoring of the default values for the object dictionary in non-volatile memory. In order to avoid restoring of parameters by mistake, the device restores

the defaults only when a specific signature is written to the appropriate sub-index. The signature is “load”. The “load” action on either CAN buses will apply to the parameters on both buses.

The signature is a 32-bit unsigned number, composed of the ASCII codes of the signature characters, according to the following table:

MSB		LSB	
d	a	o	l
64h	61h	6Fh	6Ch

On reception of the correct signature to an appropriate sub-index, the controller will restore the defaults in non-volatile memory, and then confirm the SDO transmission. **The default values are set valid only after the device is reset or power-cycled.** This means that the controller will NOT start using the default values right away, but rather continue to run from whatever values were in the Object Dictionary prior to the restore operation.

By read access, the object provides information about the module’s default parameter restoring capabilities. For all sub-indexes, this value is 1h, indicating that the controller restores defaults on command.

Object Description

Index	1011h
Name	Restore Default Parameters
Object Type	ARRAY
Data Type	UNSIGNED32

Entry Description

Sub-Index	0h
Description	Largest sub-index supported
Access	RO
PDO Mapping	No
Value Range	4
Default Value	4

Sub-Index	1h
Description	Restore all default parameters
Access	RW
PDO Mapping	No
Value Range	0x64616F6C (write access), 1h (read access)
Default Value	1h

Sub-Index	2h
Description	Restore default communication parameters
Access	RW
PDO Mapping	No
Value Range	0x64616F6C (write access), 1h (read access)
Default Value	1h

Sub-Index	3h
Description	Restore default application parameters
Access	RW
PDO Mapping	No
Value Range	0x64616F6C (write access), 1h (read access)
Default Value	1h

Sub-Index	4h
Description	Restore default manufacturer parameters
Access	RW
PDO Mapping	No
Value Range	0x64616F6C (write access), 1h (read access)
Default Value	1h

3.2.9. Object 1016h: Consumer Heartbeat Time

The Data Logger can be a consumer of heartbeat objects for a single module. This object defines the expected heartbeat cycle time for that module, and if set to zero, it is not used. When the object is non-zero, the time is a multiple of 1ms, and monitoring will start after the reception of the first heartbeat from the module. If the controller fails to receive a heartbeat from a node in the expected timeframe, it will indicate a communication error, and respond as per object 1029h.

Bits	31-24	23-16	15-0
Value	Reserved 00h	Node-ID	Heartbeat time
Encoded as		UNSIGNED8	UNSIGNED16

Object Description

Index	1016h
Name	Consumer heartbeat time
Object Type	ARRAY
Data Type	UNSIGNED32

Entry Description

Sub-Index	0h
Description	Number of entries
Access	RO
PDO Mapping	No
Value Range	4
Default Value	4

Sub-Index	1h
Description	Consumer heartbeat time
Access	RW
PDO Mapping	No
Value Range	UNSIGNED32
Default Value	0

3.2.10. Object 1017h: Producer Heartbeat Time

The controller could be configured to produce a cyclical heartbeat by writing a non-zero value to this object. The value will be given in multiples of 1ms, and a value of 0 shall disable the heartbeat.

Object Description

Index	1017h
Name	Producer heartbeat time
Object Type	VAR
Data Type	UNSIGNED16

Entry Description

Sub-Index	0h
Access	RW
PDO Mapping	No
Value Range	10 to 65535
Default Value	0

3.2.11. Object 1018h: Identity Object

The identity object indicates the data of the controller, including vendor id, device id, software and hardware version numbers, and the serial number.

In the Revision Number entry at sub-index 3, the format of the data is as shown below

MSB		LSB
Major revision number (object dictionary)	Hardware Revision	Software Version

Object Description

Index	1018h
Name	Identity Object
Object Type	RECORD
Data Type	Identity Record

Entry Description

Sub-Index	0h
Description	Number of entries
Access	RO
PDO Mapping	No
Value Range	4
Default Value	4

Sub-Index	1h
Description	Vendor ID
Access	RO
PDO Mapping	No
Value Range	0x00000055
Default Value	0x00000055 (Axiomatic)

Sub-Index	2h
Description	Product Code
Access	RO
PDO Mapping	No
Value Range	0xAA181001
Default Value	0xAA181001

Sub-Index	3h
Description	Revision Number
Access	RO
PDO Mapping	No
Value Range	UNSIGNED32
Default Value	0x00010000

Sub-Index	4h
Description	Serial Number
Access	RO
PDO Mapping	No
Value Range	UNSIGNED32
Default Value	No

3.2.12. Object 1020h: Verify Configuration

This object can be read to see what date the software (version identified in object 1018h) was compiled. The date is represented as a hexadecimal value showing day/month/year as per the format below. The time value at sub-index 2 is a hexadecimal value showing the time in a 24 hour clock

MSB		LSB
Day (in 1-Byte Hex)	Month (in 1-Byte Hex)	Year (in 2-Byte Hex)
00	00	Time (in 2-Byte Hex)

For example, a value of 0x30042014 would indicate that the software was compiled on April 30th, 2014. A time value of 0x00001842 would indicate it was compiled at 6:42pm.

Object Description

Index	1020h
Name	Verify configuration
Object Type	ARRAY
Data Type	UNSIGNED32

Entry Description

Sub-Index	0h
Description	Number of entries
Access	RO
PDO Mapping	No
Value Range	2
Default Value	2

Sub-Index	1h
Description	Configuration date
Access	RO
PDO Mapping	No
Value Range	UNSIGNED32
Default Value	No

Sub-Index	2h
Description	Configuration time
Access	RO
PDO Mapping	No
Value Range	UNSIGNED32
Default Value	No

3.2.13. Object 1029h: Error Behaviour

This object controls the state that the Data Logger will be set into in case of an error of the type associated with the sub-index.

A network fault is flagged when an RPDO is not received within the expected time period defined in the “Event Timer” of the associated communication objects, (see Section 3.2.14 for more information) or if a lifeguard or heartbeat message is not received as expected. Input faults are defined in Section 1.4, and thermocouple faults are defined in Section 1.2.

For all sub-indexes, the following definitions hold true:

- 0 = Pre-Operational (node reverts to a pre-operational state when this fault is detected)
- 1 = No State Change (node remains in the same state it was in when the fault occurred)
- 2 = Stopped (node goes into stopped mode when the fault occurs)

Object Description

Index	1029h
Name	Error Behaviour
Object Type	ARRAY
Data Type	UNSIGNED8

Entry Description

Sub-Index	0h
Description	Number of entries
Access	RO
PDO Mapping	No
Value Range	5
Default Value	5

Sub-Index	1h
Description	Communication Fault
Access	RW
PDO Mapping	No
Value Range	See above
Default Value	1 (No State Change)

Sub-Index	2h
Description	Digital Input Fault (Not Used)
Access	RW
PDO Mapping	No
Value Range	See above
Default Value	1 (No State Change)

Sub-Index	3h
Description	Analog Input Fault (AI & TC)
Access	RW
PDO Mapping	No
Value Range	See above
Default Value	1 (No State Change)

Sub-Index	4h
Description	Digital Output Fault (Not Used)
Access	RW
PDO Mapping	No
Value Range	See above
Default Value	1 (No State Change)

Sub-Index	5h
Description	Analog Output Fault (Not Used)
Access	RW
PDO Mapping	No
Value Range	See above
Default Value	1 (No State Change)

3.2.14. RPDO Behaviour

Per the CANopen® standard DS-301, the following procedure shall be used for re-mapping, and is the same for both RPDOs and TPDOs.

- Destroy the PDO by setting bit **exists** (most significant bit) of sub-index 01h of the according PDO communication parameter to 1b
- Disable mapping by setting sub-index 00h of the corresponding mapping object to 0
- Modify the mapping by changing the values of the corresponding sub-indices
- Enable mapping by setting sub-index 00h to the number of mapped objects
- Create the PDO by setting bit **exists** (most significant bit) of sub-index 01h of the according PDO communication parameter to 0b

The Data Logger can support up to four RPDO messages. All RPDOs on the controller use the similar default communication parameters, with the PDO IDs set according to the pre-defined connection set described in DS-301. Some RPDOs do not exist, there is no RTR allowed, they use 11-bit CAN-IDs (base frame valid) and they are all event-driven. While all four have valid default mappings defined (see below) only RPDO1 is enabled by default (i.e. RPDO exists).

RPDO1 Mapping at Object 1600h: Default ID 0x200 + Node ID

<i>Sub-Index</i>	<i>Value</i>	<i>Object</i>
0	4	Number of mapped application objects in PDO
1	0x25000110	Extra Received 1 PV
2	0x25000210	Extra Received 2 PV
3	0x25000310	Extra Received 3 PV
4	0x25000410	Extra Received 4 PV

RTPDO2 Mapping at Object 1601h: Default ID 0x300 + Node ID

<i>Sub-Index</i>	<i>Value</i>	<i>Object</i>
0	4	Number of mapped application objects in PDO
1	0x25000510	Extra Received 5 PV

2	0x25000610	Extra Received 6 PV
3	0x25000710	Extra Received 7 PV
4	0x25000810	Extra Received 8 PV

RPDO3 Mapping at Object 1602h: Default ID 0x400 + Node ID

Sub-Index	Value	Object
0	4	Number of mapped application objects in PDO
1	0x25000910	Extra Received 9 PV
2	0x25000A10	Extra Received 10 PV
3	0x25000B10	Extra Received 11 PV
4	0x25000C10	Extra Received 12 PV

RPDO4 Mapping at Object 1603h: Default ID 0x500 + Node ID

Sub-Index	Value	Object
0	0	Number of mapped application objects in PDO
1	0	Not used by default
2	0	Not used by default
3	0	Not used by default
4	0	Not used by default

None of them have the timeout feature enabled, i.e. the “Event Timer” on sub-index 5 is set to zero. When this is changed to a non-zero value, if the RPDO has not been received from another node within the time period defined (while in Operational mode), a network fault is activated, and the controller will go to the operational state define in Object 1029h sub-index 4.

Object Description

Index	1400h to 1403h
Name	RPDO communication parameter
Object Type	RECORD
Data Type	PDO Communication Record

Entry Description

Sub-Index	0h
Description	Number of entries
Access	RO
PDO Mapping	No
Value Range	5
Default Value	5

Sub-Index	1h
Description	COB-ID used by RPDO
Access	RW
PDO Mapping	No
Value Range	See value definition in DS-301

X	RPDOx ID
1	0200h
2	0300h
3	0400h
4	0500h

Default Value	40000000h + RPDO1 + Node ID C0000000h + RPDOx + Node-ID	
---------------	--	--

Node-ID = Node-ID of the module. The RPDO COB-IDs are automatically updated if the Node-ID is changed by LSS protocol.

80000000h in the COB-ID indicates that the PDO does not exist (destroyed)

04000000h in the COB-ID indicates that there is no RTR allowed on the PDO

Sub-Index	2h
Description	Transmission type
Access	RO
PDO Mapping	No
Value Range	See value definition in DS-301
Default Value	255 (FFh) = Event Driven

Sub-Index	3h
Description	Inhibit Time
Access	RW
PDO Mapping	No
Value Range	See value definition in DS-301
Default Value	0

Sub-Index	4h
Description	Compatibility entry
Access	RW
PDO Mapping	No
Value Range	UNSIGNED8
Default Value	0

Sub-Index	5
Description	Event-timer
Access	RW
PDO Mapping	No
Value Range	See value definition in DS-301
Default Value	0

Recall: A non-zero event timer for an RPDO means that it will result in a network fault being flagged if it has not been received within this timeframe while in Operational mode.

3.2.15. TPDO Behaviour

The Data Logger can support up to seven TPDO messages. All TPDOs on the controller use the similar default communication parameters, with the PDO IDs set according to the pre-defined connection set described in DS-301. Some TPDOs do not exist, there is no RTR allowed, they use 11-bit CAN-IDs (base frame valid) and they are all time-driven. While all have valid default mappings defined (see below) only TPDO1, TPDO2 and TPDO3 are enabled by default (i.e. TPDO exists).

TPDO1 Mapping at Object 1A00h: Default ID 0x180 + Node ID

Sub-Index	Value	Object
0	4	Number of mapped application objects in PDO
1	0x71000110	Analog Input 1 Field Value
2	0x71000210	Analog Input 2 Field Value
3	0x71000310	Analog Input 3 Field Value
4	0x71000410	Analog Input 4 Field Value

TPDO2 Mapping at Object 1A01h: Default ID 0x280 + Node ID

Sub-Index	Value	Object
0	4	Number of mapped application objects in PDO
1	0x71000510	Analog Input 5 Field Value
2	0x71000610	Analog Input 6 Field Value
3	0x71000710	Analog Input 7 Field Value
4	0x71000810	Analog Input 8 Field Value

TPDO3 Mapping at Object 1A02h: Default ID 0x380 + Node ID

Sub-Index	Value	Object
0	2	Number of mapped application objects in PDO
1	0x71000910	Analog Input 9 Field Value
2	0x71000A10	Analog Input 10 Field Value
3	0	Not used by default
4	0	Not used by default

TPDO4 Mapping at Object 1A03h: Default ID 0x480 + Node ID

Sub-Index	Value	Object
0	4	Number of mapped application objects in PDO
1	0x61000120	Thermocouple Input 1 Field Value (in Degree)
2	0x61000220	Thermocouple Input 2 Field Value
3	0	Not used by default
4	0	Not used by default

TPDO5 Mapping at Object 1A04h: Default ID 0x180 + Node ID + 1

Sub-Index	Value	Object
0	4	Number of mapped application objects in PDO
1	0x61100320	Thermocouple Input 3 Field Value (in Degree)
2	0x61100420	Thermocouple Input 4 Field Value
3	0	Not used by default
4	0	Not used by default

TPDO6 Mapping at Object 1A05h: Default ID 0x280 + Node ID + 1

Sub-Index	Value	Object
0	1	Number of mapped application objects in PDO
1	0x21610010	Cold Junction Process Value
2	0	Not used by default

3	0	Not used by default
4	0	Not used by default

TPDO4 Mapping at Object 1A06h: Default ID 0x380 + Node ID + 1

Sub-Index	Value	Object
0	2	Number of mapped application objects in PDO
1	0x50200020	Power Supply Field Value (measured)
2	0x50300020	Processor Temperature Field Value (measured)
3	0	Not used by default
4	0	Not used by default

Since only TPDO1, TPDO2 and TPDO3 have non-zero value transmission rates (i.e. Event Timer in sub-index 5 of communication object), only TPDO1, TPDO2 and TPDO3 will be automatically broadcasted when the unit goes into OPERATIONAL mode.

Object Description

Index	1800h to 1803h
Name	TPDO communication parameter
Object Type	RECORD
Data Type	PDO Communication Record

Entry Description

Sub-Index	0h
Description	Number of entries
Access	RO
PDO Mapping	No
Value Range	5
Default Value	5

Sub-Index	1h
Description	COB-ID used by TPDO
Access	RW
PDO Mapping	No
Value Range	See value definition in DS-301
Default Value	40000000h + TPDO1 + Node-ID 40000000h + TPDO2 + Node-ID 40000000h + TPDO3 + Node-ID C0000000h + TPDOx + Node-ID

X	TPDOx ID
1	0180h
2	0280h
3	0380h
4	0480h
5	0181h
6	0281h
7	0381h

Node-ID = Node-ID of the module. The TPDO COB-IDs are automatically updated if the Node-ID is changed by LSS protocol.

80000000h in the COB-ID indicates that the PDO does not exist (destroyed)
04000000h in the COB-ID indicates that there is no RTR allowed on the PDO

Sub-Index	2h
-----------	----

Description	Transmission type
Access	RO
PDO Mapping	No
Value Range	See value definition in DS-301
Default Value	254 (FEh) = Event Driven

Sub-Index	3h
Description	Inhibit Time
Access	RW
PDO Mapping	No
Value Range	See value definition in DS-301
Default Value	0

Sub-Index	4h
Description	Compatibility entry
Access	RW
PDO Mapping	No
Value Range	UNSIGNED8
Default Value	0

Sub-Index	5
Description	Event-timer
Access	RW
PDO Mapping	No
Value Range	See value definition in DS-301
Default Value	100ms (on TPDO1 to TPDO3) 0ms (on TPDO4 to TPDO7)

3.3 APPLICATION OBJECTS (DS-404)

<i>Index (hex)</i>	<i>Object</i>	<i>Object Type</i>	<i>Data Type</i>	<i>Access</i>	<i>PDO Mapping</i>
6020	DI Read State 1 Input Lines	ARRAY	BOOLEAN	RO	Yes
6100	TC Input Field Value	ARRAY	INTEGER16	RO	Yes
6130	TC Input Process Value	ARRAY	INTEGER16	RO	Yes
6110	AI Sensor Type	ARRAY	UNSIGNED16	RW	No
6112	AI Operating Mode	ARRAY	UNSIGNED8	RW	No
6132	AI Decimal Digits PV	ARRAY	UNSIGNED8	RW	No
61A0	AI Filter Type	ARRAY	UNSIGNED8	RW	No
61A1	AI Filter Constant	ARRAY	UNSIGNED16	RW	No
7100	AI Input Field Value	ARRAY	INTEGER16	RO	Yes
7120	AI Input Scaling 1 FV	ARRAY	INTEGER16	RW	No
7121	AI Input Scaling 1 PV	ARRAY	INTEGER16	RW	No
7122	AI Input Scaling 2 FV	ARRAY	INTEGER16	RW	No
7123	AI Input Scaling 2 PV	ARRAY	INTEGER16	RW	No
7130	AI Input Process Value	ARRAY	INTEGER16	RO	Yes
7148	AI Input Span Start	ARRAY	INTEGER16	RW	No
7149	AI Input Span End	ARRAY	INTEGER16	RW	No

3.3.1 Object 6020h: DI Read State 1 Input Lines

This read-only object represents the digital input state from a single input line. Refer to Section 1.2 for more information.

Object Description

Index	6020h
Name	DI Read State 1 Input Lines
Object Type	ARRAY
Data Type	BOOLEAN

Entry Description

Sub-Index	0h
Description	Largest sub-index supported
Access	RO
PDO Mapping	No
Value Range	10
Default Value	10

Sub-Index	1h to 10h (x = 1 to 10)
Description	Digital Input X State
Access	RO
PDO Mapping	Yes
Value Range	0 (OFF) or 1 (ON)
Default Value	0

3.3.2 Object 6100h: TC Input Field Value

This read-only object represents the measured temperature of the associated thermocouple input in Degree Celsius. When the corresponding sub-index in object 2160h is set to TRUE, the calculated temperature is automatically adjusted for the cold junction temperature compensation.

Object Description

Index	6100h
Name	TC Input Field Value
Object Type	ARRAY
Data Type	INTEGER16

Entry Description

Sub-Index	0h
Description	Largest sub-index supported
Access	RO
PDO Mapping	No
Value Range	4
Default Value	4

Sub-Index	1h to 4h (x = 1 to 4)
Description	TCx Input Field Value (in Degree Celsius)
Access	RO
PDO Mapping	Yes
Value Range	INTEGER16
Default Value	0

3.3.3 Object 6130h: TC Input Process Value

The read-only object represents the scaled value of the measured thermocouple temperature in mV.

Object Description

Index	6100h
Name	TC Input Process Value
Object Type	ARRAY
Data Type	INTEGER16

Entry Description

Sub-Index	0h
Description	Largest sub-index supported
Access	RO
PDO Mapping	No
Value Range	4
Default Value	4

Sub-Index	1h to 4h (x = 1 to 4)
Description	TCx Input Process Value (in mV)
Access	RO
PDO Mapping	Yes
Value Range	INTEGER16
Default Value	0

3.3.4 Object 6110h: AI Sensor Type

This object defines the type of sensor (input) which is connected to the input pin, including analog inputs and thermocouples.

Object Description

Index	6110h
Name	AI Sensor Type
Object Type	ARRAY
Data Type	UNSIGNED16

Entry Description

Sub-Index	0h
Description	Largest sub-index supported
Access	RO
PDO Mapping	No
Value Range	14
Default Value	14

Sub-Index	1h to 10h (x = 1 to 10)
Description	AIx Sensor Type
Access	RW
PDO Mapping	No
Value Range	See Table 6
Default Value	40 (Voltage)

Sub-Index	11h to 14h (x = 11 to 14)
Description	AIx Sensor Type (Thermocouple (x-10))
Access	RW
PDO Mapping	No
Value Range	See Table 1
Default Value	2 (Type K)

3.3.5 Object 6112h: AI Operating Mode

This object enables special operating modes for the input.

Object Description

Index	6112h
Name	AI Operating Mode
Object Type	ARRAY
Data Type	UNSIGNED8

Entry Description

Sub-Index	0h
Description	Largest sub-index supported
Access	RO
PDO Mapping	No
Value Range	10
Default Value	10

Sub-Index	1h to 10h (x = 1 to 10)
Description	AIx Operating Mode
Access	RW
PDO Mapping	No
Value Range	See Table 5

Default Value	1 (Normal Operation)
---------------	----------------------

3.3.6 Object 6132h: AI Decimal Digits PV

This object describes the number of digits following the decimal point (i.e. resolution) of the input data, which is interpreted with data type Integer16 in the process value object.

Example: A process value of 1.230 (Float) will be coded as 1230 in Integer16 format if the number of decimal digits is set to 3.

Object Description

Index	6132h
Name	AI Decimal Digits PV
Object Type	ARRAY
Data Type	UNSIGNED8

Entry Description

Sub-Index	0h
Description	Largest sub-index supported
Access	RO
PDO Mapping	No
Value Range	10
Default Value	10

Sub-Index	1h to 10h (x = 1 to 10)
Description	AIx Decimal Digits PV
Access	RW
PDO Mapping	No
Value Range	0 to 4
Default Value	3 [V to mV]

3.3.7 Object 61A0h: AI Filter Type

This object defines the type of data filter that will be applied to the raw input data, as read from the ADC or Timer, before it is passed to the field value object. The types of data filters are defined in Table 9, and how they are used is outlined in Section 1.4.

Object Description

Index	61A0h
Name	AI Filter Type
Object Type	ARRAY
Data Type	UNSIGNED8

Entry Description

Sub-Index	0h
Description	Largest sub-index supported
Access	RO
PDO Mapping	No
Value Range	10
Default Value	10

Sub-Index	1h to 10h (x = 1 or 10)
Description	Alx Filter Type
Access	RW
PDO Mapping	No
Value Range	See Table 9
Default Value	0 (no filter)

3.3.8 Object 61A1h: AI Filter Constant

This object defines the number of steps used in the various filters, as defined in Section 1.4.

Object Description

Index	61A1h
Name	AI Filter Constant
Object Type	ARRAY
Data Type	UNSIGNED16

Entry Description

Sub-Index	0h
Description	Largest sub-index supported
Access	RO
PDO Mapping	No
Value Range	10
Default Value	10

Sub-Index	1h to 10h (x = 1 to 10)
Description	Alx Filter Constant
Access	RW
PDO Mapping	No
Value Range	1 to 1000
Default Value	10

3.3.9 Object 7100h: AI Input Field Value

This object represents the measured value of an input that has been scaled as per manufacturer object 2102h AI Decimal Digits FV. The base unit for each type of input is

defined in Table 10, as well as the read-only resolution (decimal digits) associated with the FV.

Object Description

Index	7100h
Name	AI Input Field Value
Object Type	ARRAY
Data Type	INTEGER16

Entry Description

Sub-Index	0h
Description	Largest sub-index supported
Access	RO
PDO Mapping	No
Value Range	14
Default Value	14

Sub-Index	1h to 10h (x = 1 to 10)
Description	Analog Input X FV
Access	RO
PDO Mapping	Yes
Value Range	Data Type Specific, see Table 11
Default Value	No

3.3.10 Object 7120h: AI Input Scaling 1 FV

This object describes the field value of the first calibration point for the analog input channel, as shown in Figure 7. It also defines the “minimum” value of the analog input range when using this input as a control source for another function block, as described in Table 15 in Section 1.4. It is scaled in the physical unit of the FV, i.e. object 2102h applies to this object.

Object Description

Index	7120h
Name	AI Input Scaling 1 FV
Object Type	ARRAY
Data Type	INTEGER16

Entry Description

Sub-Index	0h
Description	Largest sub-index supported
Access	RO
PDO Mapping	No
Value Range	10
Default Value	10

Sub-Index	1h to 10h (x = 1 to 10)
Description	AIx Scaling 1 FV
Access	RW
PDO Mapping	No
Value Range	See Table 12
Default Value	500 [mV]

3.3.11 Object 7121h: AI Input Scaling 1 PV

This object defines the process value of the first calibration point for the analog input channel, as shown in Figure 7. It is scaled in the physical unit of the PV, i.e. object 6132h applies to this object.

Object Description

Index	7121h
Name	AI Input Scaling 1 PV
Object Type	ARRAY
Data Type	INTEGER16

Entry Description

Sub-Index	0h
Description	Largest sub-index supported
Access	RO
PDO Mapping	No
Value Range	10
Default Value	10

Sub-Index	1h to 10h (x = 1 to 10)
Description	AIx Scaling 1 PV
Access	RW
PDO Mapping	No
Value Range	Integer16
Default Value	500 [same as 7120h]

3.3.12 Object 7122h: AI Input Scaling 2 FV

This object describes the field value of the second calibration point for the analog input channel, as shown in Figure 7. It also defines the “maximum” value of the analog input range when using this input as a control source for another function block, as described in Table 15 in Section 1.4. It is scaled in the physical unit of the FV, i.e. object 2102h applies to this object.

Object Description

Index	7122h
Name	AI Input Scaling 2 FV
Object Type	ARRAY
Data Type	INTEGER16

Entry Description

Sub-Index	0h
Description	Largest sub-index supported
Access	RO
PDO Mapping	No
Value Range	10
Default Value	10

Sub-Index	1h to 10h (x = 1 to 10)
Description	AIx Scaling 2 FV
Access	RW
PDO Mapping	No
Value Range	See Table 12
Default Value	4500 [mV]

3.3.13 Object 7123h: AI Input Scaling 2 PV

This object defines the process value of the second calibration point for the analog input channel, as shown in Figure 7. It is scaled in the physical unit of the PV, i.e. object 6132h applies to this object.

Object Description

Index	7123h
Name	AI Input Scaling 2 PV
Object Type	ARRAY
Data Type	INTEGER16

Entry Description

Sub-Index	0h
Description	Largest sub-index supported
Access	RO
PDO Mapping	No
Value Range	10
Default Value	10

Sub-Index	1h to 10h (x = 1 to 10)
Description	AIx Scaling 2 PV
Access	RW
PDO Mapping	No
Value Range	Integer16
Default Value	4500 [same as 7122h]

3.3.14 Object 7130h: AI Input Process Value

This object represents the result of the input scaling applied per Figure 7, and gives the measured quantity scaled in the physical unit of the process value (i.e. °C, PSI, RPM, etc) with the resolution defined in object 6132h AI Decimal Digits PV.

Object Description

Index	7130h
Name	AI Input Process Value
Object Type	ARRAY
Data Type	INTEGER16

Entry Description

Sub-Index	0h
Description	Largest sub-index supported
Access	RO
PDO Mapping	No
Value Range	14
Default Value	14

Sub-Index	1h to 10h (x = 1 to 10)
Description	AIx Process Value
Access	RO
PDO Mapping	Yes
Value Range	Integer16
Default Value	No

3.3.15 Object 7148h: AI Span Start

This value specifies the lower limit where field values are expected. Field values which are lower than this limit are marked as negative overload. It is scaled in the physical unit of the FV, i.e. object 2102h applies to this object.

Object Description

Index	7148h
Name	AI Span Start
Object Type	ARRAY
Data Type	INTEGER16

Entry Description

Sub-Index	0h
Description	Largest sub-index supported
Access	RO
PDO Mapping	No
Value Range	10
Default Value	10

Sub-Index	1h to 10h (x = 1 to 10)
Description	AIx Span Start (Error Min)
Access	RW
PDO Mapping	No
Value Range	See Table 12
Default Value	200 [mV]

3.3.16 Object 7149h: AI Span End

This value specifies the upper limit where field values are expected. Field values, which are higher than this limit, are marked as positive overload. It is scaled in the physical unit of the FV, i.e. object 2102h applies to this object.

Object Description

Index	7149h
Name	AI Span End
Object Type	ARRAY
Data Type	INTEGER16

Entry Description

Sub-Index	0h
Description	Largest sub-index supported
Access	RO
PDO Mapping	No
Value Range	10
Default Value	10

Sub-Index	1h to 10h (x = 1 to 10)
Description	AIx Span End (Error Max)
Access	RW
PDO Mapping	No
Value Range	See Table 12
Default Value	4800[mV]

3.4 MANUFACTURER OBJECTS

Index (hex)	Object	Object Type	Data Type	Access	PDO Mapping
2010	DI Polarity	ARRAY	UNSIGNED8	RW	No
2020	DI Pull Up/Down Mode 1 Input Line	ARRAY	UNSIGNED8	RW	No
2030	DI Debounce Filter 1 Input Line	ARRAY	UNSIGNED8	RW	No
2100	AI Input Range	ARRAY	UNSIGNED8	RW	No
2101	AI Number of Pulses Per Revolution	ARRAY	UNSIGNED16	RW	No
2102	AI Decimal Digits FV	ARRAY	UNSIGNED8	RW	No
2103	AI Filter Frequency for ADC	ARRAY	UNSIGNED8	RW	No
2110	AI Error Detect Enable	ARRAY	UNSIGNED8	RW	No
2111	AI Error Clear Hysteresis	ARRAY	INTEGER16	RW	No
2112	AI Error Reaction Delay	ARRAY	UNSIGNED16	RW	No
2120	AI Third-Order Filter Power	ARRAY	UNSIGNED16	RW	No
2121	AI Third-Order Filter Input Coefficient N0	ARRAY	INTEGER16	RW	No
2122	AI Third-Order Filter Input Coefficient N1	ARRAY	INTEGER16	RW	No
2123	AI Third-Order Filter Input Coefficient N2	ARRAY	INTEGER16	RW	No
2124	AI Third-Order Filter Input Coefficient N3	ARRAY	INTEGER16	RW	No
2125	AI Third-Order Filter Output Coefficient N1	ARRAY	INTEGER16	RW	No
2126	AI Third-Order Filter Output Coefficient N2	ARRAY	INTEGER16	RW	No
2127	AI Third-Order Filter Output Coefficient N3	ARRAY	INTEGER16	RW	No
2160	TC Cold Junction Enabled	ARRAY	UNSIGNED8	RW	No
2161	TC Cold Junction Input PV	VAR	INTEGER16	RO	Yes
2162	TC Cold Junction Output FV	ARRAY	INTEGER16	RO	Yes
2170	TC Low Temperature Warning	ARRAY	INTEGER16	RW	No
2171	TC High Temperature Warning	ARRAY	INTEGER16	RW	No
2172	TC Low Temperature Shutdown	ARRAY	INTEGER16	RW	No
2173	TC High Temperature Shutdown	ARRAY	INTEGER16	RW	No
2174	TC Error Clear Hysteresis	ARRAY	INTEGER16	RW	No
2500	EC Extra Received Process Value	ARRAY	INTEGER16	RW	Yes
2502	EC Decimal Digits PV	ARRAY	UNSIGNED8	RW	No
2520	EC Scaling 1 PV	ARRAY	INTEGER16	RW	No

2522	EC Scaling 2 PV	ARRAY	INTEGER16	RW	No
3yz0	LTyz Input X-Axis Source	VAR	UNSIGNED8	RW	No
3yz1	LTyz Input X-Axis Number	VAR	UNSIGNED8	RW	No
3yz2	LTyz Auto Repeat	VAR	UNSIGNED8	RW	No
3yz3	LTyz X-Axis Decimal Digits PV	VAR	UNSIGNED8	RW	No
3yz4	LTyz Y-Axis Decimal Digits PV	VAR	UNSIGNED8	RW	No
3yz5	LTyz Point Response	ARRAY	UNSIGNED8	RW	No
3yz6	LTyz Point X-Axis PV	ARRAY	INTEGER32	RW	No
3yz7	LTyz Point Y-Axis PV	ARRAY	INTEGER16	RW	No
3yz8	LTyz Output Y-Axis PV	VAR	INTEGER16	RO	Yes
3300	Logic Block Enable	ARRAY	BOOLEAN	RW	No
3310	Logic Block Selected Table	ARRAY	UNSIGNED8	RO	Yes
3320	Logic Output Process Value	ARRAY	INTEGER16	RO	Yes
3x01	LB(x-3) Lookup Table Number	ARRAY	UNSIGNED8	RW	No
3x02	LB(x-3) Function Logical Operator	ARRAY	UNSIGNED8	RW	No
3x11	LB(x-3) Function A Condition 1	RECORD	UNSIGNED8	RW	No
3x12	LB(x-3) Function A Condition 2	RECORD	UNSIGNED8	RW	No
3x13	LB(x-3) Function A Condition 3	RECORD	UNSIGNED8	RW	No
3x21	LB(x-3) Function B Condition 1	RECORD	UNSIGNED8	RW	No
3x22	LB(x-3) Function B Condition 2	RECORD	UNSIGNED8	RW	No
3x23	LB(x-3) Function B Condition 3	RECORD	UNSIGNED8	RW	No
3x31	LB(x-3) Function C Condition 1	RECORD	UNSIGNED8	RW	No
3x32	LB(x-3) Function C Condition 2	RECORD	UNSIGNED8	RW	No
3x33	LB(x-3) Function C Condition 3	RECORD	UNSIGNED8	RW	No
4000	Math Block Enable	ARRAY	BOOLEAN	RW	No
4021	Math Output Scaling 1 PV	ARRAY	INTEGER16	RW	No
4023	Math Output Scaling 2 PV	ARRAY	INTEGER16	RW	No
4030	Math Output Process Value	ARRAY	INTEGER16	RO	Yes
4032	Math Output Decimal Digits PV	ARRAY	UNSIGNED8	RW	No
4y00	Math Y Input Source	ARRAY	UNSIGNED8	RW	No
4y01	Math Y Input Number	ARRAY	UNSIGNED8	RW	No
4y02	Math Y Function Number	ARRAY	UNSIGNED8	RW	No
4y03	Math Y Input Decimal Digits FV	ARRAY	UNSIGNED8	RW	No
4y20	Math Y Input Scaling 1 FV	ARRAY	INTEGER16	RW	No

4y22	Math Y Input Scaling 2 FV	ARRAY	INTEGER16	RW	No
4y40	Math Y Input Gain	ARRAY	INTEGER8	RW	No
4y50	Math Y Operator	ARRAY	UNSIGNED8	RW	No
5010	Constant Field Value	ARRAY	FLOAT32	RW	No
5020	Power Supply Field Value	VAR	FLOAT32	RO	Yes
5021	Power Supply Error Detection Enable	VAR	UNSIGNED8	RW	No
5022	Under Voltage Threshold	VAR	UNSIGNED8	RW	No
5023	Over Voltage Threshold	VAR	UNSIGNED8	RW	No
5024	Hysteresis to Clear Supply Fault	VAR	UNSIGNED8	RW	No
5030	Processor Temperature Field Value	VAR	FLOAT32	RO	Yes
5031	Enable Error Detection on Temperature	VAR	UNSIGNED8	RW	No
5032	Over Temperature Threshold	VAR	UNSIGNED8	RW	No
5033	Hysteresis to Clear Temperature Fault	VAR	UNSIGNED8	RW	No
5550	Enable Auto Updates	VAR	UNSIGNED8	RW	No
5555	Start in Operational Mode	VAR	BOOLEAN	RW	No
5B50	Change Baud Rate	VAR	UNSIGNED8	RW	No
5B51	Change Node ID	VAR	UNSIGNED8	RW	No

Where $yz = 01$ to 12 (LUT 1 to 12) and $x = 4$ to 7 (Logic 1 to 4) and $y = 1$ to 6 (Math 1 to 6)

3.4.1 Object 2010h: DI Polarity 1 Input Line

This object determines how the state read on the input pin corresponds to the logic state, in conjunction with manufacturer object 2020h, as defined in Table 4. This object is only applied to Input 8 to 10 which means sub-index 1h to 7h will not be allowed to change.

Object Description

Index	2010h
Name	DI Polarity 1 Input Line
Object Type	ARRAY
Data Type	UNSIGNED8

Entry Description

Sub-Index	0h
Description	Largest sub-index supported
Access	RO
PDO Mapping	No
Value Range	10
Default Value	10

Sub-Index	1h to 10h (x = 1 to 10)
Description	Digital Input X Polarity
Access	RW
PDO Mapping	No
Value Range	See Table 4
Default Value	0 (Normal On/Off)

3.4.2 Object 2020h: DI Pullup Mode 1 Input Line

This object determines how the state read on the input pin corresponds to the logic state, in conjunction with application object 2010h, as defined in Table 3. The options for this object are listed in Table 2, and the controller will adjust the input hardware according to what is specified. This object is only applied to Input 8 to 10 which means sub-index 1h to 7h will not be allowed to change.

Object Description

Index	2020h
Name	DI Pullup Mode 1 Input Line
Object Type	ARRAY
Data Type	UNSIGNED8

Entry Description

Sub-Index	0h
Description	Largest sub-index supported
Access	RO
PDO Mapping	No
Value Range	10
Default Value	10

Sub-Index	1h to 10h (x = 1 to 10)
Description	Digital Input X Pullup
Access	RW
PDO Mapping	No
Value Range	See Table 2
Default Value	0 (pullup disabled)

3.4.3 Object 2030h: DI Debounce Filter 1 Input Line

This object will debounce the input signal applied on a single digital input as shown in Figure 4. The options for this object are listed in Table 2.

Object Description

Index	2030h
Name	DI Debounce Filter 1 Input Line
Object Type	ARRAY
Data Type	UNSIGNED8

Entry Description

Sub-Index	0h
Description	Largest sub-index supported
Access	RO
PDO Mapping	No
Value Range	10
Default Value	10

Sub-Index	1h to 10h (x = 1 to 10)
Description	Digital Input X Pullup/Down
Access	RW
PDO Mapping	No
Value Range	See Table 2
Default Value	2 [Filter 1.78 us]

3.4.4 Object 2100h: AI Input Range

This object, in conjunction with 6110h AI Sensor Type, defines the analog input defaults (Table 6) and allowable ranges (Table 7) for objects 2111h, 7120h, 7122h, 7148h and 7149h. The number and types of ranges will vary according to what type of sensor is connected to the input, as described in Table 7.

Object Description

Index	2100h
Name	AI Input Range
Object Type	ARRAY
Data Type	UNSIGNED8

Entry Description

Sub-Index	0h
Description	Largest sub-index supported
Access	RO
PDO Mapping	No
Value Range	10
Default Value	10

Sub-Index	1h to 10h (x = 1 to 10)
Description	Analog Input X Range
Access	RW
PDO Mapping	No
Value Range	See Table 7
Default Value	0 [0-5V]

3.4.5 Object 2101h: AI Number of Pulses Per Revolution

This object is only used when a “Frequency” input type has been selected by object 6110h. The controller will automatically convert frequency measurement from Hz to RPM when a non-zero value is specified. In this case, objects 2111h, 7120h, 7122h, 7148h and 7149h will be interpreted as RPM data. Object 2100h AI Input Range must still be specified in Hertz, and should be selected according to the expected frequencies that the RPM sensor will operate in.

Object Description

Index	2101h
Name	AI Number of Pulses Per Revolution
Object Type	ARRAY
Data Type	UNSIGNED16

Entry Description

Sub-Index	0h
Description	Largest sub-index supported
Access	RO
PDO Mapping	No
Value Range	10
Default Value	10

Sub-Index	1h to 10h (x = 1 to 10)
Description	AIx Pulses per Revolution
Access	RW
PDO Mapping	No
Value Range	0 to 1000
Default Value	0

3.4.6 Object 2102h: AI Decimal Digits FV

This object describes the number of digits following the decimal point (i.e. resolution) of the input data, which is interpreted with data type Integer16 in the field value object.

Example: A field value of 1.230 (Float) will be coded as 1230 in Integer16 format if the number of decimal digits is set to 3.

In addition to the FV object 7100h, objects 2111h, 7120h, 7122h, 7148h and 7149h will also be specified with this resolution. This object is normally read-only and will be automatically adjusted by the controller as per Table 10 depending on the analog input type and range that has been selected. When object 5550h is set to FALSE (disables automatic updates), this object becomes writeable.

Object Description

Index	2102h
Name	AI Decimal Digits FV
Object Type	ARRAY
Data Type	UNSIGNED8

Entry Description

Sub-Index	0h
Description	Largest sub-index supported
Access	RO
PDO Mapping	No
Value Range	10
Default Value	10

Sub-Index	1h to 10h (x = 1 to 10)
Description	AIx Decimal Digits FV
Access	RW (only when object 5550h is false)
PDO Mapping	No
Value Range	See Table 10
Default Value	3 [Volt to mV]

3.4.7 Object 2103h: AI Filter Frequency for ADC

This object is used to specify the cutoff filter frequency for the ADC peripheral on the processor. The analog-to-digital converter is used with analog input types: voltage and current. It is also used to measure power supply voltage, and processor temperature. The available filters are listed in Table 8.

Object Description

Index	2103h
Name	AI Filter Frequency for ADC
Object Type	ARRAY
Data Type	UNSIGNED8

Entry Description

Sub-Index	0h
Description	Largest sub-index supported
Access	RO
PDO Mapping	No
Value Range	10
Default Value	10

Sub-Index	1h to 10h (x = 1 to 10)
Description	AIx ADC Filter Frequency
Access	RW
PDO Mapping	No
Value Range	See Table 8
Default Value	1 [Filter 50Hz]

3.4.8 Object 2110h: AI Error Detect Enable

This object enables error detection and reaction associated with the analog input function block. When disabled, the input will not generate an EMCY code in object 1003h Pre-Defined Error Field, nor will it disable any logic block controlled by the input should the input go out of range as defined by the objects 7148h AI Span Start and 7149h AI Span End.

Object Description

Index	2110h
Name	AI Error Detect Enable
Object Type	ARRAY
Data Type	UNSIGNED8

Entry Description

Sub-Index	0h
Description	Largest sub-index supported
Access	RO
PDO Mapping	No
Value Range	10
Default Value	10

Sub-Index	1h to 10h (x = 1 to 10)
Description	AIx Error Detect Enable
Access	RW
PDO Mapping	No
Value Range	0 (FALSE) or 1 (TRUE)
Default Value	0 [FALSE]

3.4.9 Object 2111h: AI Error Clear Hysteresis

This object is used to prevent rapid activation/clearing of an input fault flag and sending of object 1003h to the CANopen® network. Once the input has gone above/below the thresholds that define the valid operating range, it must come back into range minus/plus this value to clear the fault. It is scaled in the physical unit of the FV, i.e. object 2102h applies to this object.

Object Description

Index	2111h
Name	AI Error Clear Hysteresis
Object Type	ARRAY
Data Type	INTEGER16

Entry Description

Sub-Index	0h
Description	Largest sub-index supported
Access	RO
PDO Mapping	No
Value Range	10
Default Value	10

Sub-Index	1h to 10h (x = 1 to 10)
Description	AIx Error Clear Hysteresis
Access	RW
PDO Mapping	No
Value Range	See Table 12
Default Value	100 [mV]

3.4.10 Object 2112h: AI Error Reaction Delay

This object is used to filter out spurious signals and to prevent saturating the CANopen® network with broadcasts of object 1003h as the fault is set/cleared. Before the fault is recognized (i.e. the EMCY code is added to the pre-defined error field list), it must remain active throughout a period of time defined in this object. The physical unit for this object is milliseconds.

Object Description

Index	2112h
Name	AI Error Reaction Delay
Object Type	ARRAY
Data Type	UNSIGNED16

Entry Description

Sub-Index	0h
Description	Largest sub-index supported
Access	RO
PDO Mapping	No
Value Range	10
Default Value	10

Sub-Index	1h to 10h (x = 1 to 10)
Description	AIx Error Reaction Delay
Access	RW
PDO Mapping	No
Value Range	0 to 60,000
Default Value	1000 [ms]

3.4.11 Object 2120h: AI Third-Order Filter Power

Third order filtering of the input data is done using 16-bit fixed point math. This object tells the controller the shift value (i.e. 2^x) that was used when the coefficients were selected. See Section 1.4 for more information on the third-order low pass filter.

Object Description

Index	2120h
Name	AI Third-Order Filter Power
Object Type	ARRAY
Data Type	UNSIGNED16

Entry Description

Sub-Index	0h
Description	Largest sub-index supported
Access	RO
PDO Mapping	No
Value Range	10
Default Value	10

Sub-Index	1h to 10h (x = 1 to 10)
Description	A _x Third-Order Filter Power
Access	RW
PDO Mapping	No
Value Range	0 to 16
Default Value	10 [2 ¹⁰ = 1024]

3.4.12 Object 2121h: AI Third-Order Filter Input Coefficient N0

3.4.13 Object 2122h: AI Third-Order Filter Input Coefficient N1

3.4.14 Object 2123h: AI Third-Order Filter Input Coefficient N2

3.4.15 Object 2124h: AI Third-Order Filter Input Coefficient N3

These objects specify the 16-bit shifted input co-efficient values used in the third-order low pass filter calculation described in Section 1.4. They are all defined with a right shift value of 2¹⁰. Since coefficient N3 is set to zero, the default filter is a second-order low pass.

Object Description

Index	2121h to 2124h (x = 0 to 3)
Name	AI 3 rd Order Filter Input Coefficient N _x
Object Type	ARRAY
Data Type	INTEGER16

Entry Description

Sub-Index	0h
Description	Largest sub-index supported
Access	RO
PDO Mapping	No
Value Range	10
Default Value	10

Sub-Index	1h to 10h (y = 1 to 10)
Description	A _y 3 rd Order Filter Input Coeff N _x
Access	RW
PDO Mapping	No
Value Range	-10000 to 10000
Default Value	N0=120, N1=241, N2=120, N3=0

3.4.16 Object 2125h: AI Third-Order Filter Output Coefficient N1

3.4.17 Object 2126h: AI Third-Order Filter Output Coefficient N2

3.4.18 Object 2127h: AI Third-Order Filter Output Coefficient N3

These objects specify the 16-bit shifted output co-efficient values used in the third-order low pass filter calculation described in Section 1.4. They are all defined with a right shift value of 2¹⁰. Since coefficient N3 is set to zero, the default filter is a second-order low pass.

Object Description

Index	2125h to 2127h (x = 1 to 3)
Name	AI 3 rd Order Filter Output Coefficient Nx
Object Type	ARRAY
Data Type	INTEGER16

Entry Description

Sub-Index	0h
Description	Largest sub-index supported
Access	RO
PDO Mapping	No
Value Range	10
Default Value	10

Sub-Index	1h to 10h (y = 1 to 10)
Description	Aly 3 rd Order Filter Output Coeff Nx
Access	RW
PDO Mapping	No
Value Range	-10000 to 10000
Default Value	N1=704, N2=-164, N3=0

3.4.19 Object 2160h: TC Cold Junction Enabled

This object established whether the measured cold junction field value is added to the calculated thermocouple input value. When set to TRUE, the cold junction compensation is automatically performed on the reading.

Object Description

Index	2160h
Name	TC Cold Junction Enabled
Object Type	ARRAY
Data Type	UNSIGNED8

Entry Description

Sub-Index	0h
Description	Largest sub-index supported
Access	RO
PDO Mapping	No
Value Range	4
Default Value	4

Sub-Index	1h to 4h (x = 1 to 4)
Description	TC Cold Junction Enabled
Access	RW
PDO Mapping	No
Value Range	0 (False) or 1 (True)
Default Value	1 (True)

3.4.20 Object 2161h: TC Cold Junction Input Process Value

The read-only object is holding the raw Degree Celsius reading measured by the ADC chip directly.

Object Description

Index	2161h
Name	TC Cold Junction Input PV
Object Type	VARIABLE
Data Type	INTEGER16

Entry Description

Sub-Index	0h
Description	TC Cold Junction Input Process Value (in Degree Celsius)
Access	RO
PDO Mapping	Yes
Value Range	INTEGER16
Default Value	0

3.4.21 Object 2162h: TC Cold Junction Output Field Value

This read-only object reflected the calculated cold junction value in mV. It will be different for different thermocouple types.

Object Description

Index	2162h
Name	TC Cold Junction Output FV
Object Type	ARRAY
Data Type	INTEGER16

Entry Description

Sub-Index	0h
Description	Largest sub-index supported
Access	RO
PDO Mapping	No
Value Range	4
Default Value	4

Sub-Index	1h to 4h (x = 1 to 4)
Description	TC Cold Junction Output FV (in mV)
Access	RO
PDO Mapping	Yes
Value Range	INTEGER16
Default Value	0

3.4.22 Object 2170h: TC Low Temperature Warning

This object sets the low threshold of the normal operating temperature range for each thermocouple's input field value (object 6100h). Any FV value below this limit will set a corresponding low warning flag to the unit, as well as an EMCY code in the object 1003h.

Object Description

Index	2170h
Name	TC Low Temperature Warning
Object Type	ARRAY
Data Type	INTEGER16

Entry Description

Sub-Index	0h
Description	Largest sub-index supported
Access	RO
PDO Mapping	No
Value Range	4
Default Value	4

Sub-Index	1h to 4h (x = 1 to 4)
Description	TC Low Temperature Warning
Access	RW
PDO Mapping	No
Value Range	INTEGER16
Default Value	0

3.4.23 Object 2171h: TC High Temperature Warning

This object sets the high threshold of the normal operating temperature range for each thermocouple's input field value (object 6100h). Any FV value above this limit will set a corresponding high warning flag, as well as an EMCY code in the object 1003h.

Object Description

Index	2171h
Name	TC High Temperature Warning
Object Type	ARRAY
Data Type	INTEGER16

Entry Description

Sub-Index	0h
Description	Largest sub-index supported
Access	RO
PDO Mapping	No
Value Range	4
Default Value	4

Sub-Index	1h to 4h (x = 1 to 4)
Description	TC High Temperature Warning
Access	RW
PDO Mapping	No
Value Range	INTEGER16
Default Value	0

3.4.24 Object 2172h: TC Low Temperature Shutdown

This object sets the low threshold of the shutdown operating temperature range for each thermocouple's input field value (object 6100h). Any FV value below this limit will set a corresponding low shutdown flag, as well as setting an EMCY code in the object 1003h.

Object Description

Index	2172h
Name	TC Low Temperature Shutdown
Object Type	ARRAY
Data Type	INTEGER16

Entry Description

Sub-Index	0h
Description	Largest sub-index supported
Access	RO
PDO Mapping	No
Value Range	4
Default Value	4

Sub-Index	1h to 4h (x = 1 to 4)
Description	TC Low Temperature Shutdown
Access	RW
PDO Mapping	No
Value Range	INTEGER16
Default Value	0

3.4.25 Object 2173h: TC High Temperature Shutdown

This object sets the high threshold of the shutdown operating temperature range for each thermocouple's input field value (object 6100h). Any FV value below this limit will set a corresponding high shutdown flag, as well as setting an EMCY code in the object 1003h.

Object Description

Index	2173h
Name	TC High Temperature Shutdown
Object Type	ARRAY
Data Type	INTEGER16

Entry Description

Sub-Index	0h
Description	Largest sub-index supported
Access	RO
PDO Mapping	No
Value Range	4
Default Value	4

Sub-Index	1h to 4h (x = 1 to 4)
Description	TC High Temperature Shutdown
Access	RW
PDO Mapping	No
Value Range	INTEGER16
Default Value	0

3.4.26 Object 2174h: TC Error Clear Hysteresis

This object is used to set the value by which the TC value needs to increase or decrease to clear the fault set by an out of range.

Object Description

Index	2174h
Name	TC Error Clear Hysteresis
Object Type	ARRAY
Data Type	INTEGER16

Entry Description

Sub-Index	0h
Description	Largest sub-index supported
Access	RO
PDO Mapping	No
Value Range	4
Default Value	4

Sub-Index	1h to 4h (x = 1 to 4)
Description	TC Error Clear Hysteresis
Access	RW
PDO Mapping	No
Value Range	INTEGER16
Default Value	0

3.4.27 Object 2500h: EC Extra Received Process Value

This object provides an extra control source in order to allow other function blocks to be controlled by data received from a CANopen® RPDO. It functions similarly to any other writeable, mappable PV object.

Object Description

Index	2500h
Name	EC Extra Received Process Value
Object Type	ARRAY
Data Type	INTEGER16

Entry Description

Sub-Index	0h
Description	Largest sub-index supported
Access	RO
PDO Mapping	No
Value Range	12
Default Value	12

Sub-Index	1h to 12h (x = 1 to 12)
Description	ECx Received Process Value
Access	RW
PDO Mapping	Yes
Value Range	Integer16
Default Value	No

3.4.28 Object 2502h: EC Decimal Digits PV

This object describes the number of digits following the decimal point (i.e. resolution) of the extra control data, which is interpreted with data type Integer16 in the process value object.

Object Description

Index	2502h
Name	EC Decimal Digits PV
Object Type	ARRAY
Data Type	UNSIGNED8

Entry Description

Sub-Index	0h
Description	Largest sub-index supported
Access	RO
PDO Mapping	No
Value Range	12
Default Value	12

Sub-Index	1h to 12h (x = 1 to 12)
Description	ECx Decimal Digits PV
Access	RW
PDO Mapping	No
Value Range	0 to 4
Default Value	1 (0.1 resolution)

3.4.29 Object 2520h: EC Scaling 1 PV

This object defines the minimum value of the extra control source. It used as the Scaling 1 value by other functions blocks when the EC has been selected as the source for the X-Axis data, i.e. as seen in Figure 8. There is no physical unit associate with the data, but it uses the same resolution as the received PV as defined in object 2502h, EC Decimal Digits PV. This object must always be smaller than object 2522h EC Scaling 2 PV.

Object Description

Index	2520h
Name	EC Scaling 1 PV
Object Type	ARRAY
Data Type	INTEGER16

Entry Description

Sub-Index	0h
Description	Largest sub-index supported
Access	RO
PDO Mapping	No
Value Range	12
Default Value	12

Sub-Index	1h to 12h (x = 1 to 12)
Description	ECx Scaling 1 PV
Access	RW
PDO Mapping	No
Value Range	-32768 to 2522h sub-index X
Default Value	0

3.4.30 Object 2522h: EC Scaling 2 PV

This object defines the maximum value of the extra control source. It used as the Scaling 2 value by other functions blocks when the EC has been selected as the source for the X-Axis data, i.e. as seen in Figure 8. There is no physical unit associate with the data, but it uses the same resolution as the received PV as defined in object 2502h, EC Decimal Digits PV. This object must always be larger than object 2520h EC Scaling 1 PV.

Object Description

Index	2522h
Name	EC Scaling 2 PV
Object Type	ARRAY
Data Type	INTEGER16

Entry Description

Sub-Index	0h
Description	Largest sub-index supported
Access	RO
PDO Mapping	No
Value Range	12
Default Value	12

Sub-Index	1h to 12h (x = 1 to 12)
Description	ECx Scaling 2 PV
Access	RW
PDO Mapping	No
Value Range	2520h sub-index X to 32767
Default Value	1000 (100.0)

3.4.31 Object 3yz0h: LTyz Input X-Axis Source

This object defines the type of input that will be used to determine the X-Axis input process value for the lookup table function. The available control sources on the Data Logger are listed in Table 13. Not all sources would make sense to use as an X-Axis input, and it is the user's responsibility to select a source that makes sense for the application. A selection of "Control Source Not Used" disables the associated lookup table function block.

Object Description

Index	3yz0h (where yz = 01 to 12)
Name	LTyz Input X-Axis Source
Object Type	VARIABLE
Data Type	UNSIGNED8

Entry Description

Sub-Index	0h
Access	RW
PDO Mapping	No
Value Range	See Table 13
Default Value	0 (control not used)

3.4.32 Object 3yz1h: LTyz Input X-Axis Number

This object defines the number of the source that will be used as the X-Axis input PV for the lookup table function. The available control numbers are dependent on the source selected, as shown in Table 14. Once selected, the limits for the points on the X-Axis will be constrained by the scaling objects of the control source/number as defined in Table 15.

Object Description

Index	3yz1h (where yz = 01 to 12)
Name	LTyz Input X-Axis Number
Object Type	VARIABLE
Data Type	UNSIGNED8

Entry Description

Sub-Index	0h
Access	RW
PDO Mapping	No
Value Range	See Table 14
Default Value	0 (null control source)

3.4.33 Object 3yz2h: LTyz Auto Repeat

This object determines whether the lookup table sequence will repeat automatically once the last point in the lookup table has been completed. This object is only taken into effect when the response is set to 'Time Response'. For more details on the functionality of this object and its effect on the lookup table, please refer to section 1.5.4

Object Description

Index	3yz2h (where yz = 01 to 12)
Name	LTyz X-Axis Decimal Digits PV
Object Type	VARIABLE
Data Type	UNSIGNED8

Entry Description

Sub-Index	0h
Access	RW
PDO Mapping	No
Value Range	0 (OFF) to 1 (ON)
Default Value	0 [OFF]

3.4.34 Object 3yz3h: LTyz X-Axis Decimal Digits PV

This object describes the number of digits following the decimal point (i.e. resolution) of the X-Axis input data and the points in the lookup table. It should be set equal to the decimal digits used by the PV from the control source/number as defined in Table 15.

Object Description

Index	3yz3h (where yz = 01 to 12)
Name	LTyz X-Axis Decimal Digits PV
Object Type	VARIABLE
Data Type	UNSIGNED8

Entry Description

Sub-Index	0h
Access	RW
PDO Mapping	No
Value Range	0 to 4 (see Table 15)
Default Value	0

3.4.35 Object 3yz4h: LTyz Y-Axis Decimal Digits PV

This object describes the number of digits following the decimal point (i.e. resolution) of the Y-Axis points in the lookup table. When the Y-Axis output is going to be the input to another function block, it is recommended that this value be set equal to the decimal digits used by the block that is using the lookup table as the control source/number.

Object Description

Index	3yz4h (where yz = 01 to 12)
Name	LTyz Y-Axis Decimal Digits PV
Object Type	VARIABLE
Data Type	UNSIGNED8

Entry Description

Sub-Index	0h
Access	RW
PDO Mapping	No
Value Range	0 to 4
Default Value	0

3.4.36 Object 3yz5h: LTyz Point Response

This object determines the Y-Axis output response to changes in the X-Axis input. The value set in sub-index 1 determines the X-Axis type (i.e. data or time), while all other sub-indexes determine the response (ramp, step, ignore) between two points on the curve. The options for this object are listed in Table 16. See Figure 9 for an example of the difference between a step and ramp response.

Object Description

Index	3yz5h (where yz = 01 to 12)
Name	LTyz Point Response
Object Type	ARRAY
Data Type	UNSIGNED8

Entry Description

Sub-Index	0h
Description	Largest sub-index supported
Access	RO
PDO Mapping	No
Value Range	11
Default Value	11

Sub-Index	1h
Description	X-Axis Type
Access	RW
PDO Mapping	No
Value Range	See Table 16 (0 or 1)
Default Value	0 (x-axis data response)

Sub-Index	2h to 11h (x = 2 to 11)
Description	LTyz Point X Response
Access	RW
PDO Mapping	No
Value Range	See Table 16 (0, 1 or 2)
Default Value	1 (ramp to response)

3.4.37 Object 3yz6h: LTyz Point X-Axis PV

This object defines the X-Axis data for the 11 calibration points on the lookup table, resulting in 10 different output slopes.

When a data response is selected for the X-Axis type (sub-index 1 of object 3yz5), this object is constrained such that X1 cannot be less than the Scaling 1 value of the selected control source/number, and X11 cannot be more than the Scaling 2 value. The rest of the points are constrained by the formula below. The physical unit associate with the data will be that of the selected input, and it will use the resolution defined in object 3yz3h, LTyz X-Axis Decimal Digits PV.

MinInt16 <= X₁<= X₂<= X₃<= X₄<= X₅<= X₆<= X₇<= X₈<= X₉<= X₁₀<= X₁₁<= MaxInt16

When a time response has been selected, each point on the X-Axis can be set anywhere from 1 to 86,400,000ms.

Object Description

Index	3yz6h (where yz = 01 to 12)
Name	LTyz Point X-Axis PV
Object Type	ARRAY
Data Type	INTEGER32

Entry Description

Sub-Index	0h
Description	Largest sub-index supported
Access	RO
PDO Mapping	No
Value Range	11
Default Value	11

Sub-Index	1h to 11h (x = 1 to 11)
Description	LTyz Point X-Axis PVx
Access	RW
PDO Mapping	No
Value Range	See above (data) 1 to 86400000 (time)
Default Value	10 ^{*(x-1)} No

3.4.38 Object 3yz7h: LTyz Point Y-Axis PV

This object defines the Y-Axis data for the 11 calibration points on the lookup table, resulting in 10 different output slopes. The data is unconstrained and has no physical unit associate with it. It will use the resolution defined in object 3yz4h, LTyz Y-Axis Decimal Digits PV.

Object Description

Index	3yz7h (where yz = 01 to 12)
Name	LTyz Point Y-Axis PV
Object Type	ARRAY
Data Type	INTEGER16

Entry Description

Sub-Index	0h
Description	Largest sub-index supported
Access	RO
PDO Mapping	No
Value Range	11
Default Value	11

Sub-Index	1h to 11h (x = 1 to 11)
Description	LTyz Point Y-Axis PVx
Access	RW
PDO Mapping	No
Value Range	Integer16
Default Value	10*(x-1) [i.e. 0, 10, 20, 30, ... 100]

3.4.39 Object 3yz8h: LTyz Output Y-Axis PV

This read-only object contains the lookup table function block PV that can be used as the input source for another function block. The physical unit for this object is undefined, and it will use the resolution defined in object 3yz4h, LTyz Y-Axis Decimal Digits PV.

Object Description

Index	3yz8h (where yz = 01 to 12)
Name	LTyz Output Y-Axis PV
Object Type	VARIABLE
Data Type	INTEGER16

Entry Description

Sub-Index	0h
Access	RO
PDO Mapping	Yes
Value Range	Integer16
Default Value	No

3.4.40 Object 3300h: Logic Block Enable

This object defines whether or not the logic shown in Figure 11 will be evaluated.

Object Description

Index	3300h
Name	Logic Block Enable
Object Type	ARRAY
Data Type	BOOLEAN

Entry Description

Sub-Index	0h
Description	Largest sub-index supported
Access	RO
PDO Mapping	No
Value Range	4
Default Value	4

Sub-Index	1h to 4h (x = 1 to 4)
Description	LBx Enable
Access	RW
PDO Mapping	No
Value Range	0 (FALSE) or 1 (TRUE)
Default Value	0 [FALSE]

3.4.41 Object 3310h: Logic Block Selected Table

This read-only object reflects what table has been selected as the output source for the logic block after the evaluation shown in Figure 12 has been performed.

Object Description

Index	3310h
Name	Logic Block Selected Table
Object Type	ARRAY
Data Type	UNSIGNED8

Entry Description

Sub-Index	0h
Description	Largest sub-index supported
Access	RO
PDO Mapping	No
Value Range	4
Default Value	4

Sub-Index	1h to 4h (x = 1 to 4)
Description	LBx Selected Table
Access	RO
PDO Mapping	Yes
Value Range	1 to 12
Default Value	No

3.4.42 Object 3320h: Logic Block Output PV

This read-only object reflects the output from the selected table, interpreted as a percentage. The limits for the percentage conversion are based on the range of the lookup tables Y-Axis Output PV as shown in Table 15. This value has a fixed decimal digit value of 1 giving a resolution of 0.1%.

Object Description

Index	3320h
Name	Logic Block Output PV
Object Type	ARRAY
Data Type	UNSIGNED8

Entry Description

Sub-Index	0h
Description	Largest sub-index supported
Access	RO
PDO Mapping	No
Value Range	4
Default Value	4

Sub-Index	1h to 4h (x = 1 to 4)
Description	LBx Output PV
Access	RO
PDO Mapping	Yes
Value Range	Dependent on Selected Table
Default Value	No

3.4.43 Object 3x01h: LB(x-3) Lookup Table Numbers

This object determines which of the six lookup tables supports on the controller are associated with a particular function within the given logic block. Up to three tables can be linked to each logic function.

Object Description

Index	3x01h (where x = 4 to 7)
Name	LB(x-3) Lookup Table Numbers
Object Type	ARRAY
Data Type	UNSIGNED8

Entry Description

Sub-Index	0h
Description	Largest sub-index supported
Access	RO
PDO Mapping	No
Value Range	4
Default Value	4

Sub-Index	1h to 4h (y = A to C)
Description	LB(x-3) Lookup Table Y Number
Access	RW
PDO Mapping	No
Value Range	1 to 12
Default Value	See Table 22

3.4.44 Object 3x02h: LB(x-3) Function Logical Operator

This object determines how the results of the three conditions for each function are to be compared to one another to determine the overall state of the function output. There are up to three functions that can be evaluated in each logic block. The options for this object

are defined in Table 20. See Section 1.6 for more information about how this object is used.

Object Description

Index	3x02h (where x = 4 to 7)
Name	LB(x-3) Function Logical Operator
Object Type	ARRAY
Data Type	UNSIGNED8

Entry Description

Sub-Index	0h
Description	Largest sub-index supported
Access	RO
PDO Mapping	No
Value Range	4
Default Value	4

Sub-Index	1h to 4h (y = A to C)
Description	LB(x-3) Function Y Logical Operator
Access	RW
PDO Mapping	No
Value Range	See Table 20
Default Value	Function A = 1 (and all) Function B = 1 (and all) Function C = 0 (default)

- 3.4.45 Object 3x11h: LB(x-3) Function A Condition 1**
- 3.4.46 Object 3x12h: LB(x-3) Function A Condition 2**
- 3.4.47 Object 3x13h: LB(x-3) Function A Condition 3**
- 3.4.48 Object 3x21h: LB(x-3) Function B Condition 1**
- 3.4.49 Object 3x22h: LB(x-3) Function B Condition 2**
- 3.4.50 Object 3x23h: LB(x-3) Function B Condition 3**
- 3.4.51 Object 3x31h: LB(x-3) Function C Condition 1**
- 3.4.52 Object 3x32h: LB(x-3) Function C Condition 2**
- 3.4.53 Object 3x33h: LB(x-3) Function C Condition 3**

These objects, 3xyzh, represent Logic Block z, Function y, Condition z, where x = 4 to 7, y = 1 (A) to 3 (C), and z = 1 to 3. All of these objects are a special type of record, defined in Table 17. Information on how to use these objects is defined in Section 1.6.

Object Description

Index	3xyzh
Name	LB(x-3) Function y Condition z
Object Type	RECORD
Data Type	UNSIGNED8

Entry Description

Sub-Index	0h
Description	Largest sub-index supported
Access	RO
PDO Mapping	No
Value Range	5
Default Value	5

Sub-Index	1h
Description	Argument 1 Source
Access	RW
PDO Mapping	No
Value Range	See Table 13
Default Value	1 (CANopen® Message)

Sub-Index	2h
Description	Argument 1 Number
Access	RW
PDO Mapping	No
Value Range	See Table 14
Default Value	13 (EC Received PV 1)

Sub-Index	3h
Description	Argument 2 Source
Access	RW
PDO Mapping	No
Value Range	See Table 13
Default Value	3 (Constant PV)

Sub-Index	4h
Description	Argument 2 Number
Access	RW
PDO Mapping	No
Value Range	See Table 14
Default Value	3 (Constant FV 1)

Sub-Index	5h
Description	Operator
Access	RW
PDO Mapping	No
Value Range	See Table 18
Default Value	0 (Equals)

3.4.54 Object 4000h: Math Function Enable

The corresponding sub-index of object must be set TRUE in order for a math function block to be enabled. Otherwise, the output will always be at 0.

Object Description

Index	4000h
Name	Math Function Enable
Object Type	ARRAY
Data Type	BOOLEAN

Entry Description

Sub-Index	0h
Description	Largest sub-index supported
Access	RO
PDO Mapping	No
Value Range	2
Default Value	2

Sub-Index	1h to 6h (Y = 1 to 6)
Description	Math Y Enable
Access	RW
PDO Mapping	No
Value Range	0 (FALSE) or 1 (TRUE)
Default Value	0 [FALSE]

3.4.55 Object 4021h: Math Output Scaling 1 PV

This object defines the process value that would correspond to 0% output from the math calculation. The object would apply the resolution defined in object 4532h Math Output Decimal Digits PV. The physical unit is undefined.

Object Description

Index	4021h
Name	Math Output Scaling 1 PV
Object Type	ARRAY
Data Type	INTEGER16

Entry Description

Sub-Index	0h
Description	Largest sub-index supported
Access	RO
PDO Mapping	No
Value Range	6
Default Value	6

Sub-Index	1h to 6h (Y = 1 to 6)
Description	Math Y Output Scaling 1 PV
Access	RW
PDO Mapping	No
Value Range	-32768 to 32767
Default Value	0

3.4.56 Object 4023h: Math Output Scaling 2 PV

This object defines the process value that would correspond to 100% output from the math calculation. The object would apply the resolution defined in object 4532h Math Output Decimal Digits PV. The physical unit is undefined.

Object Description

Index	4023h
Name	Math Output Scaling 2 PV
Object Type	ARRAY
Data Type	INTEGER16

Entry Description

Sub-Index	0h
Description	Largest sub-index supported
Access	RO
PDO Mapping	No
Value Range	6
Default Value	6

Sub-Index	1h to 6h (Y = 1 to 6)
Description	Math Y Output Scaling 2 PV
Access	RW
PDO Mapping	No
Value Range	-32768 to 32767
Default Value	10000 (100.00)

3.4.57 Object 4030h: Math Output Process Value

This read-only object reflects the output from the math function block after it has been scaled by objects 4021h and 4023h. The object would apply the resolution defined in object 4032h Math Output Decimal Digits PV. The physical unit is undefined.

Object Description

Index	4030h
Name	Math Output Process Value
Object Type	ARRAY
Data Type	INTEGER16

Entry Description

Sub-Index	0h
Description	Largest sub-index supported
Access	RO
PDO Mapping	No
Value Range	6
Default Value	6

Sub-Index	1h to 6h (Y = 1 to 6)
Description	Math Y Output Process Value
Access	RO
PDO Mapping	Yes
Value Range	-32768 to 32767
Default Value	No

3.4.58 Object 4032h: Math Output Decimal Digits PV

This object describes the number of digits following the decimal point (i.e. resolution) of the output data, which is interpreted with data type Integer16 in the process value object.

Object Description

Index	4032h
Name	Math Output Decimal Digits PV
Object Type	ARRAY
Data Type	UNSIGNED8

Entry Description

Sub-Index	0h
Description	Largest sub-index supported
Access	RO
PDO Mapping	No
Value Range	6
Default Value	6

Sub-Index	1h to 6h (Y = 1 to 6)
Description	Math Y Decimal Digits PV
Access	RW
PDO Mapping	No
Value Range	0 to 4
Default Value	2 (0.01)

3.4.59 Object 4y00h: Math Y Input Source

This object defines the input sources that will be used in the mathematical calculations. Here, $y = 1$ to 6 – representing Math Block 1 to Math Block 6. If a control source is not used, the associate mathematical calculation would be ignored. The available control sources on the controller are listed in Table 13.

Object Description

Index	4y00h ($y = 1$ to 6)
Name	Math Y Input Source
Object Type	ARRAY
Data Type	UNSIGNED8

Entry Description

Sub-Index	0h
Description	Largest sub-index supported
Access	RO
PDO Mapping	No
Value Range	6
Default Value	6

Sub-Index	1h to 6h ($X = 1$ to 6)
Description	Math Y Input X Source
Access	RW
PDO Mapping	No
Value Range	See Table 13
Default Value	0 (control source not used)

3.4.60 Object 4y01h: Math Y Input Number

This object defines the number of the input source that will be used in the math calculation. The available control numbers are dependent on the source selected, as shown in Table 14. Once selected, the input value will be used in the corresponding calculation as described in Section 1.7.

Object Description

Index	4y01h ($y = 1$ to 6)
Name	Math Y Input Number
Object Type	ARRAY
Data Type	UNSIGNED8

Entry Description

Sub-Index	0h
Description	Largest sub-index supported
Access	RO
PDO Mapping	No
Value Range	6
Default Value	6

Sub-Index	1h to 6h (X = 1 to 6)
Description	Math Y Input X Number
Access	RW
PDO Mapping	No
Value Range	See Table 14
Default Value	0 (null input)

3.4.61 Object 4y02h: Math Y Input Function Number

This object defines the number of the function within the Math Block will be used in the math calculation. This object is applicable when the Input Source together with the Input Number match the Math Block that is being configured. If Input Source and Input Number match the Math Block being configured and the Function Number is 0, this object is ignored. For more details, refer to Section 1.7.

Object Description

Index	4y01h (y = 1 to 6)
Name	Math Y Input Number
Object Type	ARRAY
Data Type	UNSIGNED8

Entry Description

Sub-Index	0h
Description	Largest sub-index supported
Access	RO
PDO Mapping	No
Value Range	6
Default Value	6

Sub-Index	1h to 6h (X = 1 to 6)
Description	Math Y Input X Function Number
Access	RW
PDO Mapping	No
Value Range	0 to 3
Default Value	0 (null input)

3.4.62 Object 4y03h: Math Y Input Decimal Digits FV

This object describes the number of digits following the decimal point (i.e. resolution) of the input data, which is interpreted with data type Integer16 in the field value object.

Object Description

Index	4y03h (y = 1 to 6)
Name	Math Y Input Decimal Digits FV
Object Type	ARRAY
Data Type	UNSIGNED8

Entry Description

Sub-Index	0h
Description	Largest sub-index supported
Access	RO
PDO Mapping	No
Value Range	6
Default Value	6

Sub-Index	1h to 6h (X = 1 to 6)
Description	Math Y Input X Decimal Digits PV
Access	RW
PDO Mapping	No
Value Range	0 to 4
Default Value	2 (0.01)

3.4.63 Object 4y20h: Math Y Input Scaling 1 FV

This object defines the input field value that would correspond to 0% when scaling the input for use in the math calculation. All inputs are normalized to a percentage before being used by the math function block. The object would apply the resolution defined in object 4y03h Math Y Input Decimal Digits FV. The physical unit would match that of the input source.

Object Description

Index	4y20h (y = 1 to 6)
Name	Math Y Input Scaling 1 FV
Object Type	ARRAY
Data Type	INTEGER16

Entry Description

Sub-Index	0h
Description	Largest sub-index supported
Access	RO
PDO Mapping	No
Value Range	6
Default Value	6

Sub-Index	1h to 6h (X = 1 to 6)
Description	Math Y Input X Scaling 1 FV
Access	RW
PDO Mapping	No
Value Range	INTEGER16
Default Value	0

3.4.64 Object 4y22h: Math Y Input Scaling 2 FV

This object defines the input field value that would correspond to 100% when scaling the input for use in the math calculation. All inputs are normalized to a percentage before being used by the math function block. The object would apply the resolution defined in object 4y03h Math Y Input Decimal Digits FV. The physical unit would match that of the input source.

Object Description

Index	4y22h (y = 1 to 6)
Name	Math Y Input Scaling 2 FV
Object Type	ARRAY
Data Type	INTEGER16

Entry Description

Sub-Index	0h
Description	Largest sub-index supported
Access	RO
PDO Mapping	No
Value Range	6
Default Value	6

Sub-Index	1h to 6h (X = 1 to 6)
Description	Math Y Input X Scaling 2 FV
Access	RW
PDO Mapping	No
Value Range	INTEGER16
Default Value	10000 (100.00%)

3.4.65 Object 4y40h: Math Y Input Gain

This object can be used to adjust the 'weight' of the input in the math calculation. It is a multiplier of the input after it has been converted into a percentage, before it is used in the math calculation. This object has a fixed resolution of 2 decimal digits.

Object Description

Index	4y40h (y = 1 to 6)
Name	Math Y Input Gain
Object Type	ARRAY
Data Type	INTEGER8

Entry Description

Sub-Index	0h
Description	Largest sub-index supported
Access	RO
PDO Mapping	No
Value Range	6
Default Value	6

Sub-Index	1h to 6h (X = 1 to 6)
Description	Math Y Input X Gain
Access	RW
PDO Mapping	No
Value Range	-100 to 100
Default Value	100 (1.0)

3.4.66 Object 4y50h: Math Y Operator

This object defines the actual operators that will be used in each stage of a math calculation, as described in Section 1.7. The options for this object are listed in Table 23.

Object Description

Index	4y50h (y = 1 to 6)
Name	Math Y Operator
Object Type	ARRAY
Data Type	UNSIGNED8

Entry Description

Sub-Index	0h
Description	Largest sub-index supported
Access	RO
PDO Mapping	No
Value Range	3
Default Value	3

Sub-Index	1h to 3h (X = 1 to 3)
Description	Math Y Function X Operator
Access	RW
PDO Mapping	No
Value Range	See Table 23
Default Value	12 (Plus)

3.4.67 Object 5010h: Constant Field Value

This object is provided to allow the user to compare against a fixed value, i.e. in a conditional evaluation for a logic block. The first two values in this object are fixed at FALSE (0) and TRUE (1). There are ten other sub-indexes provide for other unconstrained data.

Object Description

Index	5010h
Name	Constant Field Value
Object Type	ARRAY
Data Type	FLOAT32

Entry Description

Sub-Index	0
Description	Largest sub-index supported
Access	RO
PDO Mapping	No
Value Range	15
Default Value	15

Sub-Index	1
Description	Constant False
Access	RO
PDO Mapping	No
Value Range	0
Default Value	0 (false)

Sub-Index	2
Description	Constant True
Access	RO
PDO Mapping	No
Value Range	1
Default Value	1 (true)

Sub-Index	3
Description	Constant FV 3
Access	RW
PDO Mapping	No
Value Range	Float32
Default Value	3.141593

Sub-Index	4
Description	Constant FV 4
Access	RW
PDO Mapping	No
Value Range	Float32
Default Value	2.718282

Sub-Index	5
Description	Constant FV 5
Access	RW
PDO Mapping	No
Value Range	Float32
Default Value	1.414214

Sub-Index	6
Description	Constant FV 6
Access	RW
PDO Mapping	No
Value Range	Float32
Default Value	1.732051

Sub-Index	7
Description	Constant FV 7
Access	RW
PDO Mapping	No
Value Range	Float32
Default Value	2.236068

Sub-Index	8
Description	Constant FV 8
Access	RW
PDO Mapping	No
Value Range	Float32
Default Value	2.50

Sub-Index	9
Description	Constant FV 9
Access	RW
PDO Mapping	No
Value Range	Float32
Default Value	5.00

Sub-Index	10
Description	Constant FV 10
Access	RW
PDO Mapping	No
Value Range	Float32
Default Value	10.00

Sub-Index	11
Description	Constant FV 11
Access	RW
PDO Mapping	No
Value Range	Float32
Default Value	20.00

Sub-Index	12
Description	Constant FV 12
Access	RW
PDO Mapping	No
Value Range	Float32
Default Value	40.00

Sub-Index	13
Description	Constant FV 13
Access	RW
PDO Mapping	No
Value Range	Float32
Default Value	60.00

Sub-Index	14
Description	Constant FV 14
Access	RW
PDO Mapping	No
Value Range	Float32
Default Value	80.00

Sub-Index	15
Description	Constant FV 15
Access	RW
PDO Mapping	No
Value Range	Float32
Default Value	100.00

3.4.68 Object 5020h: Power Supply Field Value

This read-only object is available for diagnostic feedback purposes. It reflects the measured voltage powering the controller. The physical unit for this object is volts.

Object Description

Index	5020h
Name	Power Supply Field Value
Object Type	VARIABLE
Data Type	FLOAT32

Entry Description

Sub-Index	0h
Access	RO
PDO Mapping	Yes
Value Range	0 to 70 [V]
Default Value	No

3.4.69 Object 5021h: Enable Error Detection on Power Supply

This write-able object is available to enable faults on power supply measured in the system. When this object is enabled, objects 5022h-5024h are used to determine fault triggers and fault clear thresholds. For more information please refer to Section 1.8.

Object Description

Index	5021h
Name	Enable Error Detection on Power Supply
Object Type	VARIABLE
Data Type	UNSIGNED8

Entry Description

Sub-Index	0h
Access	RW
PDO Mapping	No
Value Range	FALSE; TRUE
Default Value	TRUE (1)

3.4.70 Object 5022h: Under Voltage Threshold

This object is used to set the value at which a supply fault will trigger if the measured supply falls below it. If object 5021h is disabled, this value is ignored. For more information please refer to Section 1.8.

Object Description

Index	5022h
Name	Under Voltage Threshold
Object Type	VARIABLE
Data Type	UNSIGNED8

Entry Description

Sub-Index	0h
Access	RW
PDO Mapping	No
Value Range	0V... Object 5023h
Default Value	8 (V)

3.4.71 Object 5023h: Over Voltage Threshold

This object is used to set the value at which a supply fault will trigger if the measured supply falls above it. If object 5021h is disabled, this value is ignored. For more information please refer to Section 1.8.

Object Description

Index	5023h
Name	Over Voltage Threshold
Object Type	VARIABLE
Data Type	UNSIGNED8

Entry Description

Sub-Index	0h
Access	RW
PDO Mapping	No
Value Range	Object 522h... 36V
Default Value	35 (V)

3.4.72 Object 5024h: Hysteresis to Clear Supply Fault

This object is used to set the value by which the supply voltage needs to increase or decrease to clear the fault set by an under voltage or over voltage, respectively. If object 5021h is disabled, this value is ignored. For more information please refer to Section 1.8.

Object Description

Index	5024h
-------	-------

Name	Hysteresis to Clear Supply Fault
Object Type	VARIABLE
Data Type	UNSIGNED8

Entry Description

Sub-Index	0h
Access	RW
PDO Mapping	No
Value Range	1V...30V
Default Value	5 (V)

3.4.73 Object 5030h: Processor Temperature Field Value

This read-only object is available for diagnostic feedback purposes. It reflects the measured processor temperature of the controller. The physical unit for this object is Celsius.

Object Description

Index	5030h
Name	Processor Temperature Field Value
Object Type	VARIABLE
Data Type	FLOAT32

Entry Description

Sub-Index	0h
Access	RO
PDO Mapping	Yes
Value Range	-50 to 150 [DegC]
Default Value	No

3.4.74 Object 5031h: Enable Error Detection on Temperature

This write-able object is available to enable faults on temperature measured in the system. When this object is enabled, objects 5032h-5033h are used to determine fault triggers and fault clear thresholds. For more information please refer to Section 1.8.

Object Description

Index	5021h
Name	Enable Error Detection on Temperature
Object Type	VARIABLE
Data Type	UNSIGNED8

Entry Description

Sub-Index	0h
Access	RW

PDO Mapping	No
Value Range	FALSE; TRUE
Default Value	TRUE (1)

3.4.75 Object 5032h: Over Temperature Threshold

This object is used to set the value at which a temperature fault will trigger if the measured microcontroller temperature falls above it. If object 5031h is disabled, this value is ignored. For more information please refer to Section 1.8.

Object Description

Index	5032h
Name	Over Temperature Threshold
Object Type	VARIABLE
Data Type	UNSIGNED8

Entry Description

Sub-Index	0h
Access	RW
PDO Mapping	No
Value Range	0...150 (DegC)
Default Value	85 (DegC)

3.4.76 Object 5033: Hysteresis to Clear Temperature Fault

This object is used to set the value by which the temperature needs to decrease to clear the fault set by an over temperature event. If object 5031h is disabled, this value is ignored. For more information please refer to Section 1.8.

Object Description

Index	5033h
Name	Hysteresis to Clear Temperature Fault
Object Type	VARIABLE
Data Type	UNSIGNED8

Entry Description

Sub-Index	0h
Access	RW
PDO Mapping	No
Value Range	0...150 (DegC)
Default Value	25 (DegC)

3.4.77 Object 5550h: Enable Automatic Updates

This object allows the controller to update objects to defaults automatically when an output type is changed. Be default this object is TRUE.

Object Description

Index	5550h
Name	Enable Auto Updates
Object Type	VARIABLE
Data Type	UNSIGNED8

Entry Description

Sub-Index	0h
Access	RW
PDO Mapping	No
Value Range	0 (FALSE) or 1 (TRUE)
Default Value	1 [TRUE]

3.4.78 Object 5555h: Start in Operational Mode

This object allows the unit to start in Operational mode without requiring the presence of a CANopen® Master on the network. It is intended to be used only when running the controller as a stand-alone module. This should always be set FALSE whenever it is connected to a standard master/slave network. Sub-index 1 is for CAN1 and sub-index 2 is for CAN2. The baud rate on both CAN buses can be changed on either CAN bus.

Object Description

Index	5555h
Name	Start in Operational Mode
Object Type	VARIABLE
Data Type	UNSIGNED8

Entry Description

Sub-Index	0h
Access	RW
PDO Mapping	No
Value Range	0 (FALSE) or 1 (TRUE)
Default Value	0 [FALSE]

Sub-Index	1h
Access	RW
PDO Mapping	No
Value Range	0 (FALSE) or 1 (TRUE)
Default Value	0 [FALSE]

3.4.79 Object 5B50h: Change Baud Rate

The Data Logger could be configured to different baud rates by changing the value in this object. The options for this object are defined in Table 25. Sub-index 1 is for CAN1 and

sub-index 2 is for CAN2. The baud rate on both CAN buses can be changed on either CAN bus.

Object Description

Index	5B50h
Name	Change Baud Rate
Object Type	VARIABLE
Data Type	UNSIGNED8

Entry Description

Sub-Index	0h
Access	RW
PDO Mapping	No
Value Range	0...8
Default Value	4(125k)

Sub-Index	1h
Access	RW
PDO Mapping	No
Value Range	0...8
Default Value	4(125k)

3.4.80 Object 5B51h: Change Node ID

This object is used to change the node ID of the module. Sub-index 1 is for CAN1 and sub-index 2 is for CAN2. Both node IDs can be changed on either CAN bus.

Object Description

Index	5B51h
Name	Change Node ID
Object Type	VARIABLE
Data Type	UNSIGNED8

Entry Description

Sub-Index	0h
Access	RW
PDO Mapping	No
Value Range	Unsigned8
Default Value	32

Sub-Index	1h
Access	RW
PDO Mapping	No
Value Range	Unsigned8
Default Value	32

4 Technical Specifications

Technical Specifications:

Specifications are indicative and subject to change. Actual performance will vary depending on the application and operating conditions. Users should satisfy themselves that the product is suitable for use in the intended application. All our products carry a limited warranty against defects in material and workmanship. Please refer to our Warranty, Application Approvals/Limitations and Return Materials Process as described on www.axiomatic.com/service.html.

Inputs

Power Supply Input	12 Vdc, 24 Vdc or 48 Vdc nominal (9...60 Vdc power supply range)
Protection	Reverse polarity protection Overvoltage protection is up to 120 V.
Inputs	4 Thermocouple Inputs 7 Analog Signal Inputs (0-5 V, 0-10V, 0-20 mA, 4-20 mA) 3 Universal Signal Inputs (0-5V, 0-10V, Thermistor, 0-20 mA, 4-20 mA, PWM, Frequency or Counter, Discrete) User programmable (Refer to Table 1.0.) Inputs and Power are isolated from CAN.
Inputs Scan Rate	Each analog and universal input is scanned every 1 ms. A complete scan of all inputs is 10 ms. New measured values are ready every 10 ms. The 4 TC inputs new measured value is available every 400 ms.
Analog Grounds	10 are provided and they are common to each other.

Table 1.0 – Inputs – User Programmable Options

Thermocouple Inputs	Reads up to 4 Type J, K or T thermocouple inputs <ul style="list-style-type: none"> • Full channel to channel isolation and isolation from CAN line, other inputs and power supply • Cold junction compensation is provided. • Thermocouple input resolution is 0.1 °C. • Accuracy is +/-1 °C throughout the entire range of the thermocouple input. • 4 shield connections are provided. • The sample rate for the 4 Channels is 300 ms. 																	
Analog Input Functions	Voltage or Current Input																	
Voltage Input	0-5 V (Impedance 200 KOhm) 0-10V (Impedance 150 KOhm)																	
Current Input	0-20 mA (Impedance 125 Ohm) 4-20 mA (Impedance 125 Ohm)																	
Digital Input Functions	Discrete Input, PWM Input, Frequency Input																	
Digital Input Level	12V or 24V Threshold: Low <1.5 V High >3.5V																	
PWM Input	0 to 100% 100 Hz to 10 kHz																	
Frequency/RPM Input	0.5 Hz to 50kHz																	
Digital Input	Active High with pull-up (input 8 - 5kΩ, input 9 and input 10 – 1kΩ)																	
Input Accuracy	<table border="1"> <thead> <tr> <th>Input Type</th> <th>Input Range</th> <th>Accuracy</th> </tr> </thead> <tbody> <tr> <td rowspan="2">Voltage</td> <td>0-5V</td> <td>0.1%</td> </tr> <tr> <td>0-10V</td> <td>0.1%</td> </tr> <tr> <td>Current</td> <td>0(4)-20mA</td> <td>0.1%</td> </tr> <tr> <td>Frequency</td> <td>0.5Hz-50kHz</td> <td>1%</td> </tr> <tr> <td>PWM</td> <td>0%-100%</td> <td>1%</td> </tr> </tbody> </table> <p>Table 2.0 - Input accuracy</p>	Input Type	Input Range	Accuracy	Voltage	0-5V	0.1%	0-10V	0.1%	Current	0(4)-20mA	0.1%	Frequency	0.5Hz-50kHz	1%	PWM	0%-100%	1%
Input Type	Input Range	Accuracy																
Voltage	0-5V	0.1%																
	0-10V	0.1%																
Current	0(4)-20mA	0.1%																
Frequency	0.5Hz-50kHz	1%																
PWM	0%-100%	1%																
Input Resolution	12-bit																	

Outputs

Reference Voltages	7 provided +5V +/- 0.5% (10 mA)
--------------------	------------------------------------

General Specifications

Microprocessor	STM32F205 32-bit, 512 kByte flash memory
Typical Quiescent Current	84 mA@12Vdc; 52 mA@24Vdc
Response Time	3 mSec.
Control Logic	Standard embedded software is provided.
Communications	2 Isolated CANopen® ports 300 Vrms
User Interface	EDS File Standard CANopen tools (not supplied)
Operating Conditions	-40 to 85 °C (-40 to 185 °F)
Storage Temperature	-55 to 125 °C (-67 to 257°F)
Protection	IP67
Vibration	Random Vibration: 7.65 Grms peak Sinusoidal Component: 10 g peak Based on MIL-STD-202G, Methods 204G, 214A and 213B
Compliance	CE marking
Weight	1.30 lbs. (0.59 kg)
Packaging	High Temperature Nylon housing, Deutsch IPD P/N: EEC-5X650B 4.03 x 4.25 x 1.68 inches 102.44 x 107.96 x 42.67 mm (L x W x H including integral connector) Refer to the dimensional drawing.
Electrical Connections	48 pin Deutsch IPD connector P/N: DT13-48PABCD-R015 Mates with: Deutsch IPD P/N's DT06-12SA Plug, DT 12 Way A Key DT06-12SB Plug, DT 12 Way B Key DT06-12SC Plug, DT 12 Way C Key DT06-12SD Plug, DT 12 Way D Key For the electrical pin out, refer to Table 3.0.
Network Termination	It is necessary to terminate the network with external termination resistors. The resistors are 120 Ohm, 0.25W minimum, metal film or similar type. They should be placed between CAN_H and CAN_L terminals at both ends of the network.

5 VERSION HISTORY

Version	Date	Author	Modifications
1	July 29, 2020	Jessica Chen	Initial Draft
-	August 10, 2020	Amanda Wilkins	Marketing Review



OUR PRODUCTS

Actuator Controls
Automotive Ethernet Converters
Battery Chargers
CAN bus Controls
CAN/Wifi, CAN/Bluetooth
Current/Voltage Converters
DC/DC Power Converters
Engine Temperature Scanners
Ethernet/CAN Converters, Switches
Fan Drive Controllers
Gateways, CAN/Modbus Protocols
Gyroscope Inclinometers
Hydraulic Valve Controllers
Inclinometers, Triaxial
I/O Controls
LVDT Simulators
Machine Controls
Modbus Controls
Motor Controls
Power Supplies
PWM Signal Converters/Isolators
Resolver Signal Conditioners
Service Tools
Signal Conditioners, Converters
Strain Gauge CAN Controls
Surge Suppressors

OUR COMPANY

Axiomatic provides electronic machine controls, components, and systems to the off-highway, commercial vehicle, electric vehicle, power generator set, material handling, renewable energy and industrial OEM markets.

We innovate with engineered and off-the-shelf machine controls that add value for our customers. We emphasize service and partnership with our customers, suppliers, and employees to build long term relationships and mutual trust.

QUALITY DESIGN AND MANUFACTURING

Axiomatic in Canada operates an ISO 9001:2015 registered design and manufacturing facility.

SERVICE

All products to be returned to Axiomatic require a Return Materials Authorization Number (RMA#). Please request an RMA# from sales@axiomatic.com.

Please provide the following information when requesting an RMA number:

- Serial number, part number
- Axiomatic invoice number and date
- Hours of operation, description of problem
- Wiring set up diagram, application
- Other comments as needed

All products should be serviced by Axiomatic. Do not open the product and perform the service yourself.

DISPOSAL

Axiomatic products are electronic waste. Please follow your local environmental waste and recycling laws, regulations and policies for safe disposal or recycling of electronic waste.

WARRANTY, APPLICATION APPROVALS/LIMITATIONS

Axiomatic Technologies Corporation reserves the right to make corrections, modifications, enhancements, improvements, and other changes to its products and services at any time and to discontinue any product or service without notice. Customers should obtain the latest relevant information before placing orders and should verify that such information is current and complete. Users should satisfy themselves that the product is suitable for use in the intended application. All our products carry a limited warranty against defects in material and workmanship. Please refer to our Warranty, Application Approvals/Limitations and Return Materials Process as described on www.axiomatic.com/service.html.

CONTACTS

Axiomatic Technologies Corporation
5915 Wallace Street
Mississauga, ON
CANADA L4Z 1Z8
TEL: +1 905 602 9270
FAX: +1 905 602 9279
www.axiomatic.com

Axiomatic Technologies Oy
Höytämöntie 6
33880 Lempäälä
FINLAND
TEL: +358 103 375 750
FAX: +358 3 3595 660
www.axiomatic.fi