

# 12 RTD CHANNELS, 4 UNIVERSAL SIGNAL INPUTS CAN, SAE J1939

## USER MANUAL

P/N: AX184000

P/N: AX184000-01 – J1939 500kb/s Baud Rate

P/N: AX184000-02 – Custom J1939 Baud Rate, 1Mbits/s

## VERSION HISTORY

<b>Version</b>	<b>Date</b>	<b>Author</b>	<b>Modification</b>
1.0.0.	Nov 7, 2016	Ilona Korpelainen	Initial Draft
1.0.1.	Nov 9, 2016	Ilona Korpelainen	Installation Instructions updated
-	Dec. 5, 2016	Amanda Wilkins	Technical Specification updated
1.0.2	June 9, 2017	Amanda Wilkins	Updated pin out and drawing Added vibration compliance
1.0.2A	Sep 26, 2017	Ilona Korpelainen	Added note about high speed versions

## ACRONYMS

ACK	Positive Acknowledgement (from SAE J1939 standard)
BATT +/-	Battery positive (a.k.a. Vps) or Battery Negative (a.k.a. GND)
DIN	Digital Input used to measure active high or low signals
DM	Diagnostic Message (from SAE J1939 standard)
DTC	Diagnostic Trouble Code (from SAE J1939 standard)
EA	Electronic Assistant®, p/n AX070502 (A Service Tool for Axiomatic ECUs)
ECU	Electronic Control Unit (from SAE J1939 standard)
GND	Ground reference (a.k.a. BATT-)
I/O	Inputs and Outputs
MAP	Memory Access Protocol
NAK	Negative Acknowledgement (from SAE J1939 standard)
PDU1	A format for messages that are to be sent to a destination address, either specific or global (from SAE J1939 standard)
PDU2	A format used to send information that has been labeled using the Group Extension technique, and does not contain a destination address.
PGN	Parameter Group Number (from SAE J1939 standard)
PropA	Message that uses the Proprietary A PGN for peer-to-peer communication
PropB	Message that uses a Proprietary B PGN for broadcast communication
PWM	Pulse Width Modulation
RPM	Rotations per Minute
SPN	Suspect Parameter Number (from SAE J1939 standard)
TP	Transport Protocol
UIN	Universal input used to measure voltage, current, frequency or digital inputs
Vps	Voltage Power Supply (a.k.a. BATT+)
%dc	Percent Duty Cycle (Measured from a PWM input)

# TABLE OF CONTENTS

<b>1. OVERVIEW OF CONTROLLER</b> .....	<b>8</b>
1.1. RTD Input Function Blocks .....	9
1.2. Averaging.....	16
1.3. Universal Input Function Blocks .....	16
1.4. Input Filtering .....	19
1.5. Diagnostic Function Blocks .....	19
1.6. CAN Transmit Message Function Block.....	23
1.6.1. CAN Transmit Message Setpoints .....	23
1.6.2. CAN Transmit Signal Setpoints .....	24
1.7. CAN Receive Function Block .....	25
1.8. Available Control Sources .....	25
<b>2. INSTALLATION INSTRUCTIONS</b> .....	<b>27</b>
2.1. Dimensions and Pinout.....	27
<b>3. OVERVIEW OF J1939 FEATURES</b> .....	<b>29</b>
3.1. Introduction to Supported Messages.....	29
3.2. NAME, Address and Software ID .....	30
<b>4. ECU SETPOINTS ACCESSED WITH ELECTRONIC ASSISTANT</b> .....	<b>33</b>
4.1. Accessing the ECU Using EA.....	33
4.2. J1939 Network Parameters .....	34
4.3. RTD Input Setpoints .....	35
4.4. Universal Input Setpoints.....	35
4.5. Averaging Setpoints.....	36
4.6. CAN Transmit Setpoints .....	37
4.7. CAN Receive Setpoints .....	40
4.8. General Diagnostics Options .....	41
4.9. Diagnostics Blocks.....	42
<b>5. REFLASHING OVER CAN WITH EA BOOTLOADER</b> .....	<b>46</b>
<b>APPENDIX A - TECHNICAL SPECIFICATION</b> .....	<b>A-1</b>

Table 1 – RTD Coefficient Options..... 10

Table 2 – Predefined Callendar Van Dusen Constants ..... 10

Table 3 – Supported Suspect Parameter Numbers ..... 16

Table 4 – Universal Input Sensor Type Options..... 17

Table 5 – Debounce Time Options..... 17

Table 6 - Software Debounce Filter Times ..... 17

Table 7 – Pullup/Pulldown Resistor Options ..... 17

Table 8 – Active High/Low Options ..... 18

Table 9 – Digital Input Sensor Type versus Input State ..... 18

Table 10 – Filter Type Options ..... 19

Table 11 – Lamp Set by Event in DM1 Options ..... 22

Table 12 – FMI for Event Options..... 22

Table 13 – Low Fault FMIs and corresponding High Fault FMIs ..... 23

Table 14 – Available Control Sources and Numbers ..... 26

Table 15 – AX184000 DT13-08PA Connector Pinout..... 27

Table 16 – AX184000 DRC13-40PB Connector Pinout..... 28

Table 17 – J1939 Network Setpoints ..... 34

Table 18 – RTD Input Setpoints ..... 35

Table 19 – Universal Input Setpoints..... 36

Table 20 – Averaging Setpoints ..... 37

Table 21 – CAN Transmit Message Setpoints ..... 39

Table 22 – CAN Receive Setpoints ..... 40

Table 23 – General Diagnostics Options Setpoints..... 42

Table 24 – Diagnostic Block Setpoints..... 45

Figure 1 – AX18400 Block Diagram ..... 8

Figure 2 – Double Minimum and Maximum Error Thresholds..... 21

Figure 3 – AX184000 Dimensional Drawing ..... 27

Figure 4 – AX184000 3-wire..... 28

Figure 5 – AX184000 2-wire..... 28

Figure 6 - Screen Capture of J1939 Setpoints ..... 34

Figure 7 - Screen Capture of RTD Input Setpoints ..... 35

Figure 8 - Screen Capture of Universal Input Setpoints..... 36

Figure 9 - Screen Capture of Averaging Setpoints..... 37

Figure 10 - Screen Capture of CAN Transmit Message Setpoints ..... 38

Figure 11 - Screen Capture of CAN Receive Message Setpoints ..... 40

Figure 12 - Screen Capture of General Diagnostics Options Setpoints..... 41

Figure 13 - Screen Capture of Diagnostic Block Setpoints ..... 43

## REFERENCES

J1939	Recommended Practice for a Serial Control and Communications Vehicle Network, SAE, April 2011
J1939/21	Data Link Layer, SAE, December 2010
J1939/71	Vehicle Application Layer, SAE, March 2011
J1939/73	Application Layer-Diagnostics, SAE, February 2010
J1939/81	Network Management, SAE, May 2003
TDAX184000	Technical Datasheet, 12-Channel RTD Scanner with 4 Universal Inputs and J1939 CAN, Axiomatic Technologies 2016
UMAX07050x	User Manual V5.13.85, Electronic Assistant and USB-CAN, Axiomatic Technologies, December 2016

***This document assumes the reader is familiar with the SAE J1939 standard. Terminology from the standard is used, but not described in this document.***



NOTE: This product is supported by Electronic Assistant® V5.13.90 and higher.

# 1. OVERVIEW OF CONTROLLER

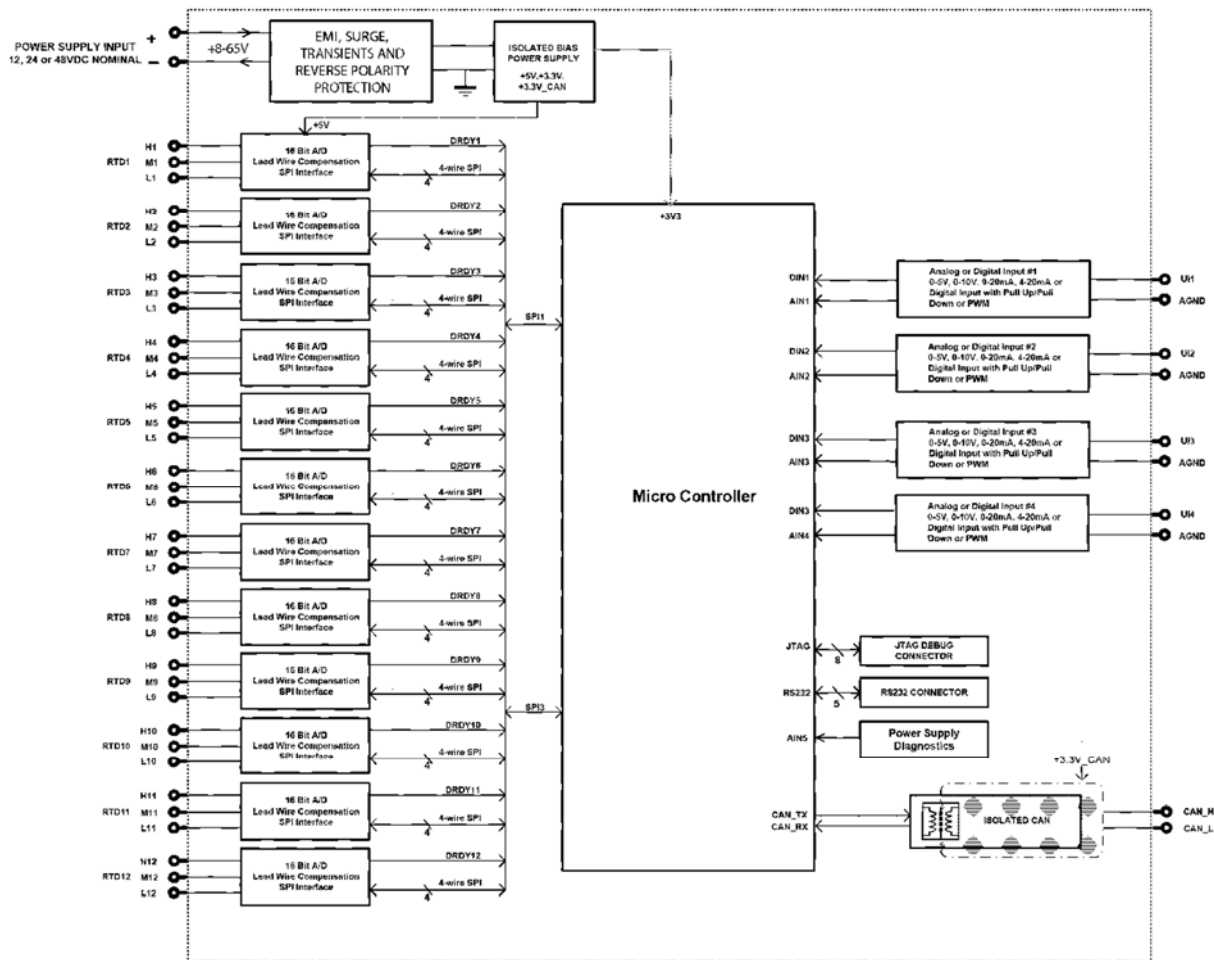

**Figure 1 – AX18400 Block Diagram**

The 12 RTD Scanner monitors 12 3-wire or 2-wire RTD inputs and provides the temperature information over a SAE J1939 CAN bus. All channels of temperature data are automatically sent over the CAN bus when power is applied with no additional programming or configuration needed. In addition, four configurable universal signal inputs are provided.

The controller has four Universal inputs that can be configured to measure analog voltage or current, frequency/PMW or digital signal. Measured input data can be sent to a SAE J1939 CAN Network.

A *Windows*-based Axiomatic Electronic Assistant® (EA) is used to configure the controller via an USB-CAN (AX070501) device. Configurable properties, EA setpoints, are outlined in chapter 4. Setpoint configuration can be saved in a file which can be used to easily program the same configuration into another 12 RTD Scanner. Throughout this document EA setpoint names are referred with bolded text in double-quotes and the setpoint option is referred with italicized text in single-quotes. For example, “**Input Sensor Type**” setpoint set to option ‘*Voltage 0 to 5V*’.

In this document, the configurable properties of the ECU are divided into function blocks, namely RTD Input Function Block, Averaging, Universal Input Function Block, Diagnostic Function Block, CAN Transmit Message Function Block and CAN Receive Message Function Block. These function blocks are presented in detail in next subchapters.

The 12 RTD Scanner can be ordered using the following part numbers depending on the application.

AX184000	Controller with the default J1939 baud rate (250kbits/s).
AX184000-01	Controller with the 500kbits/s J1939 baud rate.
AX184000-02	Controller with a custom 1Mbits/s J1939 baud rate.

## 1.1. RTD Input Function Blocks

There are twelve RTD channels on the AX184000, each with three pins at the connector for 3-wire and 2-wire connections. Resistance of the RTD is determined with dedicated onboard ADCs. Hardware wire lead resistance compensation is utilized in 3-wire connection.

The resistance measurement is implemented by deriving both reference voltage, for the ADC, and measurement excitation voltage from the same source, thus errors common to both voltages, such as temperature drift and noise, cancel out each other.

In 3-wire connection two closely matched currents flow from RTD\_H and RTD\_M pins to RTD\_L pin. First current flows through wire lead 1, RTD and lead 3. Second current flows through wire lead 2 and wire lead 3. Typically, all three leads of a 3-wire RTD have same length and, thus, the same lead resistance. As both currents have the same value, the circuit implements hardware compensation for the lead wire resistance and the differential voltage between RTD\_H and RTD\_M pins depends only on the value of the excitation current and RTD resistance.

In 2-wire connection the RTD is connected to RTD\_H and RTD\_L pins. Excitation current flows from RTD\_H pin through wire lead 1, RTD and lead 3. Thus the lead wire resistance effects on measured voltage. In 2-wire connection any lead wire resistance compensation can be done only by calibration.

Temperature value of the RDT channel is calculated from the measured resistance by using Callendar Van Dusen equation. According to IEC751, the non-linearity of the platinum thermometer can be expressed as:

$$R_t = R_0[1 + At + Bt^2 + C(t - 100)t^3] \quad \text{in which } C \text{ is only applicable when } t < 0 \text{ } ^\circ\text{C}.$$

The coefficients A, B and C for the standard sensor are stated at IEC751.

The AX18400 has five predefined Callendar Van Dusen Coefficient sets. Predefined coefficient set is selected with “**RTD Coefficient**” setpoint. “**RTD Coefficient**” setpoint options are listed in Table 1 and associated Callendar Van Dusen Constants are listed in Table 2. The ‘User Defined’ option allows Callendar Van Dusen constants to be manually set to whatever is defined for the connected sensor.

0	<i>IEC 0.00385</i>
1	<i>JIS 0.003916</i>
2	<i>US 0.003902</i>
3	<i>Legacy 0.003920</i>
4	<i>SAMA 0.003923</i>
5	<i>User Defined</i>

**Table 1 – RTD Coefficient Options**

	<b>Constant A (E-03)</b>	<b>Constant B (E-07)</b>	<b>Constant C (E-012)</b>
<b>0</b>	<i>3.90830</i>	<i>-5.77500</i>	<i>-4.18301</i>
<b>1</b>	<i>3.974673</i>	<i>-5.89730</i>	<i>-4.35300</i>
<b>2</b>	<i>3.96</i>	<i>-5.93</i>	<i>-4.30</i>
<b>3</b>	<i>3.9848</i>	<i>-5.870</i>	<i>-4.000</i>
<b>4</b>	<i>3.981531</i>	<i>-5.853116</i>	<i>-4.354530</i>
<b>5</b>	<i>User Defined</i>	<i>User Defined</i>	<i>User Defined</i>

**Table 2 – Predefined Callendar Van Dusen Constants**

Temperature SPN for the RTD channel can be selected with “Temperature Suspect Parameter Number” setpoint. The SPN drop list includes all temperature SPNs from the J1939-71 standard published up to January of 2009. List of supported SPNs and associated size, PGN, Transmit rate, index and priority are listed in Table 3.

Each SPN that is supported by the 12 RTD Scanner has a predefined size (1 or 2 bytes) and consequently resolution and offset, associated with it.

One-byte parameters have a resolution of 1°C/bit and an offset of -40°C, resulting in a measurable range of -40°C to 210°C. Temperatures outside of that range are sent as either the minimum or maximum value allowable.

Two-byte parameters have a resolution of 0.03125°C/bit and an offset of -273°C, resulting in a measurable range of -273°C to 1735°C. Temperatures outside of that range are sent as either the minimum or maximum value allowable.

When RTD Input block is associated with CAN Transmit (Chapter 1.6) or Diagnostic block (Chapter 1.5), parameters from the SPN list are loaded as default values for the block in question, therefore it is recommended to select SPNs for the RTD channels prior to adjusting Diagnostic and CAN Transmit message setpoints. If an SPN is not supported by the drop list, the user can select a zero SPN, which then allows them to define the SPN and PGN per application requirements.

“RTD Offset” setpoint allows user to define small calibration offset. Offset is defined in Ohms and added to the measured RTD resistance before conversion to Temperature.

In addition to Diagnostic Blocks (Chapter 1.5), which when associated to RTD input allow double over or under temperature detection, there is open circuit detection associated with each RTD channel. Each ADC monitors its reference voltage every 1s. If reference voltage is not present an open circuit fault is flagged. If diagnostic message generation is enabled, by setting “**Open Circuit**,

**Generate Diagnostic Message**” as ‘True’, diagnostic message is sent after delay time defined with **“Open Circuit Delay”** setpoint. In case channel the channel in question is associated with a CAN Transmit error indicator (0xFE, 0xFEFF, 0xFEFFFF) is used instead of measurement data. Open Circuit fault is associated with ‘FMI 5 – Current Below Normal or Open Circuit’ and ‘Amber Warning Lamp’.

The 12 RTD Scanner keeps a log of the last 10 scans of raw ADC measurement data. If the raw data has not changed after 10 scans, the scanner will stop broadcasting the ‘frozen’ data, and start sending the error indicator (0xFE, 0xFEFF, 0xFEFFFF) instead. No DTC is associated with this condition, so the DM11 will not be changed should this happen on one or more channels. This is a redundant safety feature, and should never occur.

ADC sample rate is 50ms.

SPN	Description	Size (Bytes)	PGN	Rate	Index	Priority
0	User Defined	0	0	0	0	0
52	Engine Intercooler Temperature	1	65262	1000	7	6
75	Steering Axle Temperature	1	65273	1000	1	6
79	Road Surface Temperature	2	65269	1000	7	6
90	Power Takeoff Oil Temperature	1	65264	100	1	6
105	Engine Intake Manifold 1 Temperature	1	65270	500	3	6
110	Engine Coolant Temperature	1	65262	1000	1	6
120	Hydraulic Retarded Oil Temperature	1	65275	1000	2	6
169	Cargo Ambient Temperature	2	65276	1000	5	6
170	Cab Interior Temperature	2	65269	1000	2	6
171	Ambient Air Temperature	2	65269	10000	4	6
172	Engine Air Inlet Temperature	1	65269	1000	6	6
173	Engine Exhaust Gas Temperature	2	65270	500	6	6
174	Engine Fuel Temperature 1	1	65262	1000	2	6
175	Engine Oil Temperature 1	2	65262	1000	3	6
176	Engine Turbocharger Oil Temperature	2	65262	1000	5	6
177	Transmission Oil Temperature	2	65272	1000	5	6
242	Tire Temperature	2	65268	10000	3	6
412	Engine Exhaust Gas Recirculation 1 Temperature	2	65188	1000	7	6
441	Auxiliary Temperature 1	1	65164	0	1	7
442	Auxiliary Temperature 2	1	65164	0	2	7
578	Drive Axle Temperature	1	65273	1000	3	6
1122	Engine Alternator Bearing 1 Temperature	1	65191	1000	1	7
1123	Engine Alternator Bearing 2 Temperature	1	65191	1000	2	7
1124	Engine Alternator Winding 1 Temperature	1	65191	1000	3	7
1125	Engine Alternator Winding 2 Temperature	1	65191	1000	4	7
1126	Engine Alternator Winding 3 Temperature	1	65191	1000	5	7
1131	Engine Intake Manifold 2 Temperature	1	65189	500	1	6
1132	Engine Intake Manifold 3 Temperature	1	65189	500	2	6
1133	Engine Intake Manifold 4 Temperature	1	65189	500	3	6

1135	Engine Oil Temperature 2	2	65188	1000	1	6
1136	Engine ECU Temperature	2	65188	1000	3	6
1137	Engine Exhaust Gas Port 1 Temperature	2	65187	1000	1	6
1138	Engine Exhaust Gas Port 2 Temperature	2	65187	1000	3	6
1139	Engine Exhaust Gas Port 3 Temperature	2	65187	1000	5	6
1140	Engine Exhaust Gas Port 4 Temperature	2	65187	1000	7	6
1141	Engine Exhaust Gas Port 5 Temperature	2	65186	1000	1	6
1142	Engine Exhaust Gas Port 6 Temperature	2	65186	1000	3	6
1143	Engine Exhaust Gas Port 7 Temperature	2	65186	1000	5	6
1144	Engine Exhaust Gas Port 8 Temperature	2	65186	1000	7	6
1145	Engine Exhaust Gas Port 9 Temperature	2	65185	1000	1	6
1146	Engine Exhaust Gas Port 10 Temperature	2	65185	1000	3	6
1147	Engine Exhaust Gas Port 11 Temperature	2	65185	1000	5	6
1148	Engine Exhaust Gas Port 12 Temperature	2	65185	1000	7	6
1149	Engine Exhaust Gas Port 13 Temperature	2	65184	1000	1	6
1150	Engine Exhaust Gas Port 14 Temperature	2	65184	1000	3	6
1151	Engine Exhaust Gas Port 15 Temperature	2	65184	1000	5	6
1152	Engine Exhaust Gas Port 16 Temperature	2	65184	1000	7	6
1153	Engine Exhaust Gas Port 17 Temperature	2	65183	1000	1	6
1154	Engine Exhaust Gas Port 18 Temperature	2	65183	1000	3	6
1155	Engine Exhaust Gas Port 19 Temperature	2	65183	1000	5	6
1156	Engine Exhaust Gas Port 20 Temperature	2	65183	1000	7	6
1157	Engine Main Bearing 1 Temperature	2	65182	1000	1	6
1158	Engine Main Bearing 2 Temperature	2	65182	1000	3	6
1159	Engine Main Bearing 3 Temperature	2	65182	1000	5	6
1160	Engine Main Bearing 4 Temperature	2	65182	1000	7	6
1161	Engine Main Bearing 5 Temperature	2	65181	1000	1	6
1162	Engine Main Bearing 6 Temperature	2	65181	1000	3	6
1163	Engine Main Bearing 7 Temperature	2	65181	1000	5	6
1164	Engine Main Bearing 8 Temperature	2	65181	1000	7	6
1165	Engine Main Bearing 9 Temperature	2	65180	1000	1	6
1166	Engine Main Bearing 10 Temperature	2	65180	1000	3	6
1167	Engine Main Bearing 11 Temperature	2	65180	1000	5	6
1172	Engine Turbocharger 1 Compressor Inlet Temperature	2	65178	1000	7	6
1173	Engine Turbocharger 2 Compressor Inlet Temperature	2	65178	1000	1	6
1174	Engine Turbocharger 3 Compressor Inlet Temperature	2	65178	1000	3	6
1175	Engine Turbocharger 4 Compressor Inlet Temperature	2	65178	1000	5	6
1180	Engine Turbocharger 1 Turbine Inlet Temperature	2	65176	1000	1	6
1181	Engine Turbocharger 2 Turbine Inlet Temperature	2	65176	1000	3	6
1182	Engine Turbocharger 3 Turbine Inlet Temperature	2	65176	1000	5	6
1183	Engine Turbocharger 4 Turbine Inlet Temperature	2	65176	1000	7	6

1184	Engine Turbocharger 1 Turbine Outlet Temperature	2	65175	1000	1	6
1185	Engine Turbocharger 2 Turbine Outlet Temperature	2	65175	1000	3	6
1186	Engine Turbocharger 3 Turbine Outlet Temperature	2	65175	1000	5	6
1187	Engine Turbocharger 4 Turbine Outlet Temperature	2	65175	1000	7	6
1212	Engine Auxiliary Coolant Temperature	1	65172	500	2	6
1636	Engine Intake Manifold 1 Air Temperature (High Resolution)	2	65129	1000	1	6
1637	Engine Coolant Temperature (High Resolution)	2	65129	1000	3	6
1638	Hydraulic Temperature	1	65128	1000	1	6
1687	Auxiliary Heater Outlet Coolant Temperature	1	65133	1000	1	6
1688	Auxiliary Heater Input Air Temperature	1	65133	1000	2	6
1800	Battery 1 Temperature	1	65104	1000	1	6
1801	Battery 1 Temperature	1	65104	1000	2	6
1802	Engine Intake Manifold 5 Temperature	1	65189	1000	4	6
1803	Engine Intake Manifold 6 Temperature	1	65189	500	5	6
2433	Engine Exhaust Gas Temperature - Right Manifold	2	65031	500	1	6
2434	Engine Exhaust Gas Temperature - Left Manifold	2	65031	500	3	6
2629	Engine Turbocharger 1 Compressor Outlet Temperature	2	64979	500	1	6
2630	Engine Charge Air Cooler 1 Outlet Temperature	2	65129	1000	7	6
2799	Engine Turbocharger 2 Compressor Outlet Temperature	2	64979	1000	3	6
2800	Engine Turbocharger 3 Compressor Outlet Temperature	2	64979	1000	5	6
2801	Engine Turbocharger 4 Compressor Outlet Temperature	2	64979	1000	7	6
2986	Engine Intake Valve Actuation System Oil Temperature	2	65129	1000	5	6
3031	Aftertreatment 1 SCR Catalyst Tank Temperature	1	65110	1000	2	6
3241	Aftertreatment 1 Exhaust Gas Temperature 1	2	64948	500	1	6
3242	Aftertreatment 1 Diesel Particulate Filter Intake Gas Temperature		64948	500	3	6
3245	Aftertreatment 1 Exhaust Gas Temperature 3	2	64947	500	1	6
3246	Aftertreatment 1 Diesel Particulate Filter Outlet Gas Temperature	2	64947	500	3	6
3249	Aftertreatment 1 Exhaust Gas Temperature 2	2	64946	500	1	6
3250	Aftertreatment 1 Diesel Particulate Filter Intermediate Gas Temperature	2	64946	500	3	6
3275	Aftertreatment 2 Exhaust Gas Temperature 1	2	64945	500	1	6

3276	Aftertreatment 2 Diesel Particulate Filter Intake Gas Temperature	2	64945	500	3	6
3279	Aftertreatment 2 Exhaust Gas Temperature 3	2	64944	500	1	6
3280	Aftertreatment 2 Diesel Particulate Filter Outlet Gas Temperature	2	64944	500	3	6
3283	Aftertreatment 2 Exhaust Gas Temperature 2	2	64943	500	1	6
3284	Aftertreatment 2 Diesel Particulate Filter Intermediate Gas Temperature	2	64943	500	3	6
3468	Engine Fuel Temperature 2	1	64930	500	5	4
3515	Aftertreatment 1 SCR Catalyst Reagent Temperature 2	1	64923	1000	1	6
3823	Transmission Torque Converter Oil Outlet Temperature	2	64917	1000	2	6
3831	Aftertreatment 1 Secondary Air Temperature	2	64877	500	3	6
3834	Aftertreatment 2 Secondary Air Temperature	2	64876	500	3	6
4076	Engine Coolant Temperature 2	1	64870	1000	1	6
4151	Engine Exhaust Gas Temperature Average	2	64851	500	1	5
4152	Engine Exhaust Gas Temperature Average - Bank 2	2	64851	500	3	5
4153	Engine Exhaust Gas Temperature Average - Bank 1	2	64851	500	5	5
4193	Engine Coolant Pump Outlet Temperature	1	64870	1000	2	6
4288	Engine Exhaust Valve Actuation System Oil Temperature	2	64870	1000	4	6
4289	Aftertreatment 1 Three Way Catalytic Converter Intake Gas Temperature	2	64838	500	1	6
4290	Aftertreatment 1 Three Way Catalytic Converter Outlet Gas Temperature	2	64838	500	3	6
4295	Aftertreatment 2 Three Way Catalytic Converter Intake Gas Temperature	2	64837	500	1	6
4296	Aftertreatment 2 Three Way Catalytic Converter Outlet Gas Temperature	2	64837	500	3	6
4337	Aftertreatment 1 SCR Dosing Reagent Temperature	1	64833	500	3	6
4360	Aftertreatment 1 SCR Catalyst Intake Gas Temperature	2	64830	500	1	6
4363	Aftertreatment 1 SCR Catalyst Outlet Gas Temperature	2	64830	500	4	6
4368	Aftertreatment 1 SCR Catalyst Reagent Tank 2 Temperature	1	64829	1000	2	6
4390	Aftertreatment 2 SCR Dosing Reagent Temperature	1	64827	500	3	6
4413	Aftertreatment 2 SCR Catalyst Intake Gas Temperature	2	64824	500	1	6
4415	Aftertreatment 2 SCR Catalyst Outlet Gas Temperature	2	64824	500	4	6
4420	Aftertreatment 2 SCR Catalyst Reagent Temperature 2	1	64822	1000	1	6

4427	Aftertreatment 2 SCR Catalyst Tank Temperature	1	64821	1000	2	6
4434	Aftertreatment 2 SCR Catalyst Reagent Tank 2 Temperature	1	64820	1000	2	6
4750	Engine Exhaust Gas Recirculation 1 (EGR1) Cooler Intake Temperature	2	64879	0	3	6
4753	Aftertreatment 1 Gas Oxidation Catalyst Intake Gas Temperature	2	64802	500	1	6
4754	Aftertreatment 1 Gas Oxidation Catalyst Outlet Gas Temperature	2	64802	500	3	6
4759	Aftertreatment 2 Gas Oxidation Catalyst Intake Gas Temperature	2	64801	500	1	6
4760	Aftertreatment 2 Gas Oxidation Catalyst Outlet Gas Temperature	2	64801	500	3	6
4765	Aftertreatment 1 Diesel Oxidation Catalyst Intake Gas Temperature	2	64800	500	1	6
4766	Aftertreatment 1 Diesel Oxidation Catalyst Outlet Gas Temperature	2	64800	500	3	6
4771	Aftertreatment 2 Diesel Oxidation Catalyst Intake Gas Temperature	2	64799	500	1	6
4772	Aftertreatment 2 Diesel Oxidation Catalyst Outlet Gas Temperature	2	64799	500	3	6
4809	Aftertreatment 1 Warm Up Diesel Oxidation Catalyst Intake Temperature	2	64794	500	1	6
4810	Aftertreatment 1 Warm Up Diesel Oxidation Catalyst Outlet Temperature	2	64794	500	3	6
5020	Engine Exhaust Gas Recirculation 1 (EGR1) Mixer Intake Temperature	2	64870	1000	6	6
5148	Low Voltage Disconnect Temperature	1	64769	1000	4	6
5255	Engine Exhaust Gas Recirculation 2 (EGR2) Temperature	2	64767	1000	1	6
5256	Engine Exhaust Gas Recirculation 2 (EGR2) Mixer Intake Temperature	2	64767	0	3	6
5258	Engine Exhaust Gas Recirculation 2 (EGR2) Cooler Intake Temperature	2	64766	1000	1	6
5280	Engine Charge Air Cooler 1 Precooler Intake Temperature	2	64759	1000	1	6
5281	Engine Charge Air Cooler 1 Precooler Outlet Temperature	2	64759	1000	3	6
5283	Engine Charge Air Cooler 1 Intake Temperature	2	64758	1000	1	6
5284	Engine Charge Air Cooler 1 Ambient Air Temperature	2	64758	1000	3	6
5286	Engine Charge Air Cooler 2 Precooler Intake Temperature	2	64757	1000	1	6
5287	Engine Charge Air Cooler 2 Precooler Outlet Temperature	2	64757	1000	3	6
5289	Engine Charge Air Cooler 2 Intake Temperature	2	64756	1000	1	6

5290	Engine Charge Air Cooler 2 Outlet Temperature	2	64756	1000	3	6
5291	Engine Charge Air Cooler 2 Ambient Air Temperature	2	64756	1000	5	6
5315	Aftertreatment 2 Warm Up Diesel Oxidation Catalyst Intake Temperature	2	64749	500	1	6
5316	Aftertreatment 2 Warm Up Diesel Oxidation Catalyst Outlet Temperature	2	64749	500	3	6
5456	Aftertreatment 1 Hydrocarbon Doser Intake Fuel Temperature	1	64869	500	6	6

**Table 3 – Supported Suspect Parameter Numbers**

### 1.2. Averaging

Averaging block calculates average temperature of the selected RTD channels and can be used for example to produce data for Engine Average Information message. There are three Averaging blocks with twelve selectable “**Averaging Value**” ’s, which can be selected to be any of the twelve RTD channels. When, “**Averaging Value**” is set to ‘Disabled’, the value is omitted from average calculation. New average value is calculated every 100ms. By default, Averaging 1 is set to produce average temperature of all twelve RTD channels, Averaging 2 is set to produce average temperature of RTD channels 1 to 6 and Averaging 3 is set to produce average temperature of RTD channels 7 to 12. Outputs of the Averaging blocks are associated with CAN Transmit 13 to produce PGN 64851 Engine Average Information per J1939-71, January 2009.

### 1.3. Universal Input Function Blocks

The four Universal Inputs can be configured to measure voltage, current, frequency, pulse width (PWM) or digital signal. Universal Input setpoint group has the “**Input Sensor Type**” setpoint, which is used to configure input type. Selecting input type effects on other setpoints and how they are interpreted and should thus be selected first on this block. The input sensor types for Universal Inputs are listed in Table 4.

0	<i>Disabled</i>
12	<i>Voltage 0 to 5 V</i>
13	<i>Voltage 0 to 10 V</i>
20	<i>Current 0 to 20 mA</i>
21	<i>Current 4 to 20 mA</i>
40	<i>Frequency 0.5 to 50 Hz</i>
41	<i>Frequency 10 Hz to 1 kHz</i>
42	<i>Frequency 100 Hz to 10 kHz</i>
50	<i>PWM Low Frequency (&lt;1kHz)</i>
51	<i>PWM High Frequency (&gt;100Hz)</i>
60	<i>Digital (normal)</i>

61	<i>Digital (inverse)</i>
62	<i>Digital (latched)</i>
70	<i>Counter</i>

**Table 4 – Universal Input Sensor Type Options**

On Universal Input analog voltage (i.e. 0-5V, 0-10V) or current (0-20mA, 4-20mA) signals go directly to a 12-bit analog-to-digital converter (ADC) on the processor. The voltage input is a high impedance input protected against shorts to GND or Vcc. In current mode, a 249Ω resistor is used to measure the input signal. Analog signals should be connected to the GND reference pins provided on the connector.

0	<i>None</i>
1	<i>111ns</i>
2	<i>1.78us</i>
3	<i>14.22us</i>

**Table 5 – Debounce Time Options**

An additional software debounce filter can be used with Digital Input types for filtering the inputs using longer time constants than with the default debounce filter. The available software implemented debounce times are listed in Table 6.

0	<i>0ms</i>
1	<i>10ms</i>
2	<i>20ms</i>
3	<i>40ms</i>
4	<i>100ms</i>
5	<i>200ms</i>
6	<i>400ms</i>
7	<i>1000ms</i>

**Table 6 - Software Debounce Filter Times**

Frequency/RPM or Pulse Width Modulated (PWM) “**Input Sensor Type**” options connect an input to 16-bit timer pin on the processor. “**Debounce Time**” setpoint is used to select an input capture filter for the timer pin in question. “**Pulse Per Revolution**” setpoint is only associated with the frequency input type. If the setpoint is set to *True*, then the input data will be reported as in rotations-per-minute (RPM). Otherwise, frequency inputs are measured in Hertz.

Universal Inputs have all available three Digital “**Input Sensor Type**” options: Normal, Inverse and Latched. With digital input sensor types, the input measurement is given, either 1 (ON) or 0 (OFF). The Universal inputs measure digital voltage with 2V threshold.

On Frequency, PWM and digital input modes 10kΩ pull-up or pull-down resistors can be enabled or disabled by setting the value of the “**Pullup/Pulldown Resistor**” setpoint. Setpoint options are given in Table 7. By default, pull-down resistors are enabled for all inputs.

0	<i>Pullup/down Off</i>
1	<i>22 kΩ Pullup</i>
2	<i>22 kΩ Pulldown</i>

**Table 7 – Pullup/Pulldown Resistor Options**

“**Active High/Active Low**” setpoint is used to configure how signal high and low are interpreted. Setpoint options are given in Table 8. By default, all inputs are selected to be Active High, which means that signal high is interpreted as 1(ON) and signal low as 0(OFF).

0	<i>Active High</i>
1	<i>Active Low</i>

**Table 8 – Active High/Low Options**

Table 9 shows the effect of different digital input types on input signal measurement interpretation with recommended “**Pullup/Pulldown Resistor**” and “**Active High/Low**” combinations. Fault diagnostics are not available for digital input types.

<b>Input Sensor Type</b>		<b>Pulldown Active High</b>	<b>Pullup Active Low</b>	<b>Input measured (state)</b>
6	<i>Digital (normal)</i>	High	Low or Open	1 (ON)
		Low or Open	High	0 (OFF)
61	<i>Digital (inverse)</i>	High or Open	Low	1 (ON)
		Low	High or Open	0 (OFF)
62	<i>Digital (latched)</i>	High to Low	Low to High	0 (no change)
		Low to High	High to Low	1 (state change)

**Table 9 – Digital Input Sensor Type versus Input State**

The “**Minimum Range**” and “**Maximum Range**” setpoints are used to define range of the signal input outputs as a control source. For example, if “**Maximum Range**” is set to 4V for an input, the control signal is saturated at 4V if input signal rises above 4V. The “**Minimum Range**” and “**Maximum Range**” setpoints are interpreted in input types units, thus they should be re-adjusted after editing “**Input Sensor Type**”.

Software filters can be applied to the measured input signal. Setpoints “**Software Filter Type**” and “**Software Filter Constant**” are used to configure the software filter. By default, no filter is applied to the signal. Software filtering is described in detail in section below.

Input sample rate is 10ms for voltage, current and digital input types. Frequency, PWM and Counter sample rate depend on input signal frequency.

## 1.4. Input Filtering

Measured input data from universal inputs can be filtered to form desired CAN message data. Input filters are configured with “**Filter Type**” and “**Filter Constant**” setpoints. Filters are configured for each input individually.

0	<i>No Filtering</i>
1	<i>Moving Average</i>
2	<i>Repeating Average</i>

**Table 10 – Filter Type Options**

“**Filter Type**” setpoint defines the type of software filter used. Setpoint options are ‘*No Filtering*’, ‘*Moving Average*’ and ‘*Repeating Average*’. The ‘*No Filtering*’ option applies no filtering to the measured input data. The ‘*Moving Average*’ option applies the transfer function below to the measured input data, where  $Value_N$  is the current value of the CAN message data,  $Value_{N-1}$  is the previous CAN message data and Filter Constant is the value of the “**Filter Constant setpoint**”.

Equation 1 - Moving Average Transfer Function:

$$Value_N = Value_{N-1} + \frac{(Input - Value_{N-1})}{Filter\ Constant}$$

Equation 2 - Repeating Average Transfer Function:

$$Value = \frac{\sum_0^N Input_N}{N}$$

The ‘*Repeating Average*’ option applies the transfer function above to the measured input data, where N is value of the “**Filter Constant**” setpoint. At every reading of the input value, the value is added to the sum. At every N<sup>th</sup> read, the sum is divided by N, and the result is new CAN message data. The sum is set to zero for the next read and summing is started again.

## 1.5. Diagnostic Function Blocks

The 12 RTD Scanner supports diagnostic messaging. DM1 message is a message, containing Active Diagnostic Trouble Codes (DTC) that is sent to the J1939 network in case a fault has been detected. A Diagnostic Trouble Code is defined by the J1939 standard as a four-byte value.

In addition to supporting the DM1 message, the following are supported:

SPN	Suspect Parameter Number	(user defined)
FMI	Failure Mode Identifier	(see Table 12 and Table 13)
CM	Conversion Method	(always set to 0)
OC	Occurrence Count	(number of times the fault has happened)
DM2	Previously Active Diagnostic Trouble Codes	Sent only on request
DM3	Diagnostic Data Clear/Reset of Previously Active DTCs	Done only on request

DM11	Diagnostic Data Clear/Reset for Active DTCs	Done only on request
------	---	----------------------

Fault detection and reaction is a standalone functionality that can be configured to monitor and report diagnostics of various controller parameters. The 12 RTD Scanner supports 19 Diagnostics Definitions, each freely configurable by the user.

By default, the monitoring of operating voltage, CPU temperature and receive message timeouts is configured to diagnostics blocks 1, 2 and 3. Diagnostic blocks 4 to 15 are set to monitor RTD inputs 1 to 12 temperature, by default. In case any of these diagnostics blocks are needed for some other use, the default settings can be adjusted by the user to suit the application.

When, an RTD channel is associated with a Diagnostic Block with “Function Type to Monitor” and “Function Parameter to Monitor” setpoints, all the SPNs of the Diagnostic Block in question are initialized with the SPN of the selected SPN channel. Thus “Function Type to Monitor” and “Function Parameter to Monitor” setpoints should be set before adjusting SPNs.

There are 4 fault types that can be used, “**Minimum and maximum error**”, “**Absolute value error**”, “**State error**” and “**Double minimum and maximum error**”.

**Minimum and maximum error** has two thresholds, “MIN Shutdown” and “MAX Shutdown” that have configurable, independent diagnostics parameters (SPN, FMI, Generate DTCs, delay before flagging status). In case the parameter to monitor stays between these two thresholds, the diagnostic is not flagged.

**Absolute value error** has one configurable threshold with configurable parameters. In case the parameter to monitor stays below this threshold, the diagnostic is not flagged.

**State error** is similar to the Absolute value error, the only difference is that State error does not allow the user to specify specific threshold values; thresholds ‘1’ and ‘0’ are used instead. This is ideal for monitoring state information, such as received message timeouts.

**Double minimum and maximum error** lets user to specify four thresholds, each with independent diagnostic parameters. The diagnostic status and threshold values is determined and expected as show in Figure 2 below.

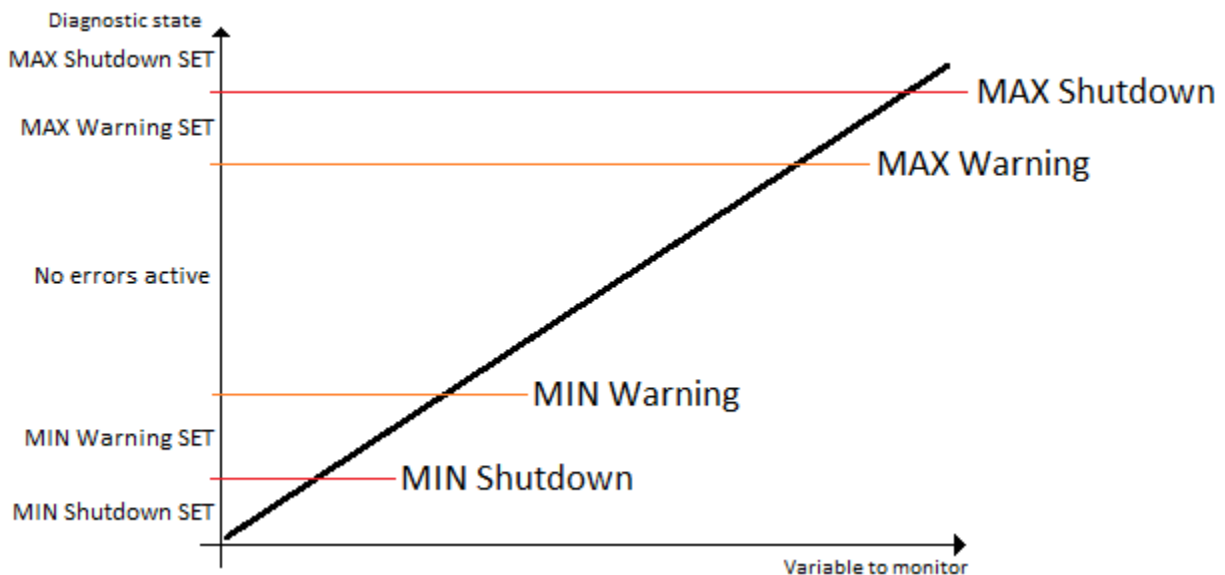

**Figure 2 – Double Minimum and Maximum Error Thresholds**

While there are no active DTCs, the 12 RTD Scanner will send “No Active Faults” message. If a previously inactive DTC becomes active, a DM1 will be sent immediately to reflect this. As soon as the last active DTC goes inactive, a DM1 indicating that there are no more active DTCs will be sent.

If there is more than one active DTC at any given time, the regular DM1 message will be sent using a multipacket message to the Requester Address using the Transport Protocol (TP).



At power up, the DM1 message will not be broadcasted until after 5 second delay. This is done to prevent any power up or initialization conditions from being flagged as an active error on the network.

When the fault is linked to a DTC, a non-volatile log of the occurrence count (OC) is kept. As soon as the controller detects a new (previously inactive) fault, it will start decrementing the “**Delay before Event is flagged**” timer for that Diagnostic function block. If the fault has remained present during the delay time, then the controller will set the DTC to active, and will increment the OC in the log. A DM1 will immediately be generated that includes the new DTC. The timer is provided so that intermittent faults do not overwhelm the network as the fault comes and goes, since a DM1 message would be sent every time the fault shows up or goes away.

By default, the fault flag is cleared when error condition that has caused it goes away. The DTC is made Previously Active and is it is no longer included in the DM1 message. To identify a fault having happened, even if the condition that has caused is one away, the “**Event Cleared only by DM11**” setpoint can be set to ‘True’. This configuration enables DTC to stay Active, even after the fault flag has been cleared, and be included in DM1 message until a Diagnostic Data Clear/Reset for Active DTCs (DM11) has been requested.

As defined by J1939 Standard the first byte of the DM1 message reflects the Lamp status. “**Lamp Set by Event**” setpoint determines the lamp type set in this byte of DTC. “**Lamp Set by Event**”

setpoint options are listed in Table 11. By default, the ‘Amber, Warning’ lamp is typically the one set to be any active fault.

0	<i>Protect</i>
1	<i>Amber Warning</i>
2	<i>Red Stop</i>
3	<i>Malfunction</i>

**Table 11 – Lamp Set by Event in DM1 Options**

“**SPN for Event**” defines suspect parameter number used as part of DTC. The default value zero is not allowed by the standard, thus no DM will be sent unless “**SPN for Event**” is configured to be different from zero. **It is user’s responsibility to select SPN that will not violate J1939 standard.** When the “**SPN for Event**” is changed, the OC of the associated error log is automatically reset to zero.

0	<i>Data Valid But Above Normal Operational Range - Most Severe Level</i>
1	<i>Data Valid But Below Normal Operational Range - Most Severe Level</i>
2	<i>Data Intermittent</i>
3	<i>Voltage Above Normal, Or Shorted To High Source</i>
4	<i>Voltage Below Normal, Or Shorted To Low Source</i>
5	<i>Current Below Normal Or Open Circuit</i>
6	<i>Current Above Normal Or Grounded Circuit</i>
7	<i>Mechanical Error</i>
8	<i>Abnormal Frequency Or Pulse Width Or Period</i>
9	<i>Abnormal Update Rate</i>
10	<i>Abnormal Rate Of Change</i>
11	<i>Root Cause Not Known</i>
12	<i>Bad Component</i>
13	<i>Out Of Calibration</i>
14	<i>Special Instructions</i>
15	<i>Data Valid But Above Normal Operating Range – Least Severe Level</i>
16	<i>Data Valid But Above Normal Operating Range – Moderately Severe Level</i>
17	<i>Data Valid But Below Normal Operating Range – Least Severe Level</i>
18	<i>Data Valid But Below Normal Operating Range – Moderately Severe Level</i>
19	<i>Network Error</i>
20	<i>Data Drifted High</i>
21	<i>Data Drifted Low</i>
31	<i>Condition Exists</i>

**Table 12 – FMI for Event Options**

Every fault has associated a default FMI with them. The used FMI can be configured with “**FMI for Event**” setpoint, presented in Table 12. When an FMI is selected from Low Fault FMIs in Table 13 for a fault that can be flagged either high or low occurrence, it is recommended that the user would select the high occurrence FMI from the right column of Table 13. There is no automatic setting of High and Low FMIs in the firmware, the user can configure these freely.

Low Fault FMIs	High Fault FMIs
----------------	-----------------

<i>FMI=1, Data Valid But Below Normal Operation Range – Most Severe Level</i>	<i>FMI=0, Data Valid But Above Normal Operational Range – Most Severe Level</i>
<i>FMI=4, Voltage Below Normal, Or Shorted to Low Source</i>	<i>FMI=3, Voltage Above Normal, Or Shorted To High Source</i>
<i>FMI=5, Current Below Normal Or Open Circuit</i>	<i>FMI=6, Current Above Normal Or Grounded Circuit</i>
<i>FMI=17, Data Valid But Below Normal Operating Range – Least Severe Level</i>	<i>FMI=15, Data Valid But Above Normal Operating Range – Least Severe Level</i>
<i>FMI=18, Data Valid But Below Normal Operating Level – Moderately Severe Level</i>	<i>FMI=16, Data Valid But Above Normal Operating Range – Moderately Severe Level</i>
<i>FMI=21, Data Drifted Low</i>	<i>FMI=20, Data Drifted High</i>

**Table 13 – Low Fault FMIs and corresponding High Fault FMIs**

## 1.6. CAN Transmit Message Function Block

The CAN Transmit function block is used to send any output from another function block (i.e. RTD input, Universal input, Averaging, CAN receive) to the J1939 network. The AX184000 ECU has sixteen CAN Transmit Messages and each message has four completely user defined signals. By default, CAN Transmit Messages 1 to 12 are associated with RTD inputs 1 to 12. And CAN Transmit Message 13 is set to produce PGN 64851 Engine Average message. Remaining three transmit messages follow defaults indicated in next subchapters.

When, an RTD channel is associated with a CAN transmit message as Signal 1 Source with “**Control Source**” and “**Control Number**” setpoints, if SPN of the RTD channel is selected from the list of supported suspect parameter numbers Table 3, Signals 2 to 4 Source is set to 0 and CAN Transmit Message setpoints are initialized with associated parameters. Thus “**Control Source**” and “**Control Number**” setpoints should be set, before adjusting other CAN Transmit message setpoints.

Transmit Message “**Transmit PGN**”, “**Repetition Rate**”, “**Transmit Message Priority**”, “**Transmit Data Size**” and “**Transmit Message Priority**” are loaded from Table 3. Signal “**Transmit Data Resolution**”, “**Transmit Data Offset**”, “**Transmit Data Minimum**” and “**Transmit Data Maximum**” are set per “**Transmit Data Size**”: One-byte parameters have a resolution of 1°C/bit and an offset of -40°C, resulting in a measurable range of -40°C to 210°C and two-byte parameters have a resolution of 0.03125°C/bit and an offset of -273°C, resulting in a measurable range of -273°C to 1735°C.

If a fault is flagged for a CAN Transmit message source error indicator (0xFE, 0xFEFF, 0xFEFFFF) is send instead of the source data.

### 1.6.1. CAN Transmit Message Setpoints

Each CAN Transmit Message setpoint group includes setpoints that effect the whole message and are thus mutual for all signals of the message. These setpoints are presented in this section. The setpoints that configure an individual signal are presented in next section.

The “**Transmit PGN**” setpoint sets PGN used with the message. **User should be familiar with the SAE J1939 standard, and select values for PGN/SPN combinations as appropriate from section J1939/71.**

“**Repetition Rate**” setpoint defines the interval used to send the message to the J1939 network. If the “**Repetition Rate**” is set to zero, the message is disabled unless it shares its PGN with another message. In case of a shared PGN repetition rate of the LOWEST numbered message are used to send the message ‘bundle’.



At power up, transmitted message will not be broadcasted until after a 5 second delay. This is done to prevent any power up or initialization conditions from creating problems on the network.

By default, all messages are sent on Proprietary B PGNs as broadcast messages. Thus “**Transmit Message Priority**” is always initialized to 6 (low priority) and the “**Destination Address**” setpoint is not used. This setpoint is only valid when a PDU1 PGN has been selected, and it can be set either to the Global Address (0xFF) for broadcasts, or sent to a specific address as setup by the user.

### 1.6.2. CAN Transmit Signal Setpoints

Each CAN transmit message has four associated signals, which define data inside the Transmit message. “**Control Source**” setpoint together with “**Control Number**” setpoint define the signal source of the message. “**Control Source**” and “**Control Number**” options are listed in Table 14. Setting “**Control Source**” to ‘*Control Not Used*’ disables the signal.

“**Transmit Data Size**” setpoint determines how many bits, signal reserves from the message. “**Transmit Data Index in Array**” determines in which of 8 bytes of the CAN message LSB of the signal is located. Similarly, “**Transmit Bit Index in Byte**” determines in which of 8 bits of a byte the LSB is located. These setpoints are freely configurable, thus **it is the User’s responsibility to ensure that signals do not overlap and mask each other.**

“**Transmit Data Resolution**” setpoint determines the scaling done on the signal data before it is sent to the bus. “**Transmit Data Offset**” setpoint determines the value that is subtracted from the signal data before it is scaled. Offset and Resolution are interpreted in units of the selected source signal.

## 1.7. CAN Receive Function Block

The CAN Receive function block is designed to take any SPN from the J1939 network, and use it as an input to another function block (i.e. Outputs).

The “**Receive Message Enabled**” is the most important setpoint associated with this function block and it should be selected first. Changing it will result in other setpoints being enabled/disabled as appropriate. By default, ALL receive messages are disabled.

Once a message has been enabled, a Lost Communication fault will be flagged if that message is not received off the bus within the “**Receive Message Timeout**” period. This could trigger a Lost Communication event as described in section 1.5. In order to avoid timeouts on a heavily saturated network, it is recommended to set the period at least three times longer than the expected update rate. To disable the timeout feature, simply set this value to zero, in which case the received message will never trigger a Lost Communication fault.

By default, all control messages are expected to be sent to the 12 RTD Scanner on Proprietary B PGNs. However, should a PDU1 message be selected, the 12 RTD Scanner can be setup to receive it from any ECU by setting the “**Specific Address that sends the PGN**” to the Global Address (0xFF). If a specific address is selected instead, then any other ECU data on the PGN will be ignored.

The “**Receive Data Size**”, “**Receive Data Index in Array (LSB)**”, “**Receive Bit Index in Byte (LSB)**”, “**Receive Resolution**” and “**Receive Offset**” can all be used to map any SPN supported by the J1939 standard to the output data of the Received function block.

As mentioned earlier, a CAN receive function clock can be selected as the source of the control input for the output function blocks. When this is the case, the “**Received Data Min (Off Threshold)**” and “**Received Data Max (On Threshold)**” setpoints determine the minimum and maximum values of the control signal. As the names imply, they are also used as the On/Off thresholds for digital output types. These values are in whatever units the data is AFTER the resolution and offset is applied to CAN receive signal.

12 RTD Scanner supports up to four unique CAN Receive Messages. Default setpoint values are listed in section 4.

## 1.8. Available Control Sources

Many of the Function Blocks have selectable input signals, which are determined with “[**Name**] **Source**” and “[**Name**] **Number**” setpoints. Together, these setpoints uniquely select how the I/O of the various function blocks are linked together. “[**Name**] **Source**” setpoint determines the type of the source and “[**Name**] **Number**” selects the actual source if there is more than one of the same type. Available “[**Name**] **Source**” options and associated “[**Name**] **Number**” ranges are listed in Table 14. All sources, except “CAN message reception timeout”, are available for all blocks, including output control blocks and CAN Transmit messages. Thought input Sources are freely selectable, not all options would make sense for any particular input, and it is up to the user to program the controller in a logical and functional manner.

<b>Sources</b>	<b>Number Range</b>	<b>Notes</b>
<i>0: Control Not Used</i>	N/A	When this is selected, it disables all other setpoints associated with the signal in question.
<i>1: Received CAN Message</i>	1 to 5	User must enable the function block, as it is disabled by default.
<i>2: RTD Input</i>	1 to 12	
<i>3: Universal Input Measured</i>	1 to 4	
<i>4: Averaging</i>	1 to 3	
<i>5: Power Supply Measured</i>	0 to 255	Measured power supply value in Volts. The Parameter sets the threshold in Volts to compare with.
<i>5: Processor Temperature Measured</i>	0 to 255	Measured processor temperature in °C. The Parameter sets the threshold in Celcius to compare with.
<i>7: CAN Reception Timeout</i>	N/A	Only available in Diagnostic blocks.

**Table 14 – Available Control Sources and Numbers**



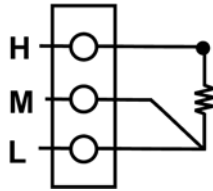

**Figure 4 – AX184000 3-wire  
RTD Input Wiring**

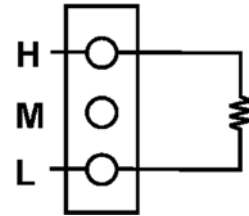

**Figure 5 – AX184000 2-wire  
RTD Input Wiring**

PIN#	Description	PIN#	Description	PIN#	Description	PIN#	Description	PIN#	Description
1	RTD 2_High	5	RTD 7_Medium	9	RTD 12_Low	13	RTD 4_Medium	17	RTD 9_Low
2	RTD 3_Medium	6	RTD 8_Low	10	Analog GND	14	RTD 5_Low	18	RTD 11_High
3	RTD 4_Low	7	RTD 10_High	11	RTD 1_Low	15	RTD 7_High	19	RTD 12_Medium
4	RTD 6_High	8	RTD 11_Medium	12	RTD 3_High	16	RTD 8_Medium	20	Universal Input 2

PIN#	Description	PIN#	Description	PIN#	Description	PIN#	Description	PIN#	Description
21	RTD 1_Medium	25	RTD 6_Low	29	RTD 12_High	33	RTD 3_Low	37	RTD 9_High
22	RTD 2_Low	26	RTD 8_High	30	Analog GND	34	RTD 5_High	38	RTD 10_Medium
23	RTD 4_High	27	RTD 9_Medium	31	RTD 1_High	35	RTD 6_Medium	39	RTD 11_Low
24	RTD 5_Medium	28	RTD 10_Low	32	RTD 2_Medium	36	RTD 7_Low	40	Universal Input 1

**Table 16 – AX184000 DRC13-40PB Connector Pinout**

### 3. OVERVIEW OF J1939 FEATURES

---

The software was designed to provide flexibility to the user with respect to messages sent from the ECU by providing:

- Configurable ECU Instance in the NAME (to allow multiple ECUs on the same network)
- Configurable Input Parameters
- Configurable PGN and Data Parameters
- Configurable Diagnostic Messaging Parameters, as required
- Diagnostic Log, maintained in non-volatile memory

#### 3.1. Introduction to Supported Messages

The ECU is compliant with the standard SAE J1939, and supports following PGNs from the standard.

##### From J1939-21 – Data Link Layer

- Request 59904 0x00EA00
- Acknowledgement 59392 0x00E800
- Transport Protocol – Connection Management 60416 0x00EC00
- Transport Protocol – Data Transfer Message 60160 0x00EB00
- Proprietary B from 65280 0x00FF00  
to 65535 0x00FFFF

##### From J1939-73 – Diagnostics

- DM1 – Active Diagnostic Trouble Codes 65226 0x00FECA
- DM2 – Previously Active Diagnostic Trouble Codes 65227 0x00FECB
- DM3 – Diagnostic Data Clear/Reset for Previously Active DTCs 65228 0x00FECC
- DM11 – Diagnostic Data Clear/Reset for Active DTCs 65235 0x00FED3
- DM14 – Memory Access Request 55552 0x00D900
- DM15 – Memory Access Response 55296 0x00D800
- DM16 – Binary Data Transfer 55040 0x00D700

##### From J1939-81 – Network Management

- Address Claimed/Cannot Claim 60928 0x00EE00
- Commanded Address 65240 0x00FED8

##### From J1939-71 – Vehicle Application Layer

- ECU Identification Information 64965 0x00FDC5
- Software Identification 65242 0x00FEDA
- Component Identification 65259 0x00FEEB
- All of the temperature SPNs from this section, and their corresponding PGNs

ECU Identification Information, Software Identification and Component Identification PGNs are not supported as part of the default configurations, but they can be selected as desired for transmit function blocks.

Setpoints are accessed using standard Memory Access Protocol (MAP) with proprietary addresses. The Electronic Assistant<sup>®</sup> (EA) allows for quick and easy configuration of the unit over CAN network.

### 3.2. NAME, Address and Software ID

The 6 Input 5 Output Valve Controller I/O ECU has the following default for the J1939 NAME. The user should refer to the SAE J1939/81 standard for more information on these parameters and their ranges.

Arbitrary Address Capable	Yes
Industry Group	0, Global
Vehicle System Instance	0
Vehicle System	0, Non-specific system
Function	125, Axiomatic I/O Controller
Function Instance	3, Axiomatic AX020510
ECU Instance	0, First Instance
Manufacture Code	162, Axiomatic Technologies
Identity Number	Variable, uniquely assigned during factory programming for each ECU

The ECU Instance is a configurable setpoint associated with the NAME. Changing this value will allow multiple ECUs of this type to be distinguishable from one another when they are connected on the same network.

The default value of the “ECU Address” setpoint is 128 (0x80), which is the preferred starting address for self-configurable ECUs as set by the SAE in J1939 tables B3 and B7. The EA will allow the selection of any address between 0 and 253. ***It is user’s responsibility to select an address that complies with the standard.*** The user must also be aware that since the unit is arbitrary address capable, if another ECU with a higher priority NAME contends for the selected address, the 6 Input 5 Output Valve Controller I/O will continue select the next highest address until it finds one that it can claim. See J1939/81 for more details about address claiming.

### ECU Identification Information

PGN 64965	ECU Identification Information	-ECUID
Transmission Repetition Rate:	On request	
Data Length:	Variable	
Extended Data Page:	0	
Data Page:	0	
PDU Format:	253	
PDU Specific:	197 PGN Supporting Information:	
Default Priority:	6	

Parameter Group Number: 64965 (0x00FDC5)

Start Position	Length	Parameter Name	SPN
a	Variable	ECU Part Number, Delimiter (ASCII "**")	2901
b	Variable	ECU Serial Number, Delimiter (ASCII "**")	2902
c	Variable	ECU Location, Delimiter (ASCII "**")	2903
d	Variable	ECU Type, Delimiter (ASCII "**")	2904
e	Variable	ECU Manufacturer Name, Delimiter (ASCII "**")	4304

(a)\*(b)\*(c)\*(d)\*(e)\*

## Software Identifier

PGN 65242 Software Identification - SOFT

Transmission Repetition Rate: On request

Data Length: Variable

Extended Data Page: 0

Data Page: 0

PDU Format: 254

PDU Specific: 218 PGN Supporting Information:

Default Priority: 6

Parameter Group Number: 65242 (0xFEDA)

Start Position	Length	Parameter Name	SPN
1	1 Byte	Number of software identification fields	965
2-n	Variable	Software identification(s), Delimiter (ASCII "**")	234

Byte 1 is set to 5, and the identification fields are as follows.

**(Part Number)\*(Version)\*(Date)\*(Owner)\*(Description)**

The EA shows all this information in “General ECU Information”, as shown below.

*Note: The information provided in the Software ID is available for any J1939 service tool which supports the PGN -SOFT.*

### Component Identification

PGN 65259	Component Identification	-CI
Transmission Repetition Rate:	On request	
Data Length:	Variable	
Extended Data Page:	0	
Data Page:	0	
PDU Format:	254	
PDU Specific:	235 PGN Supporting Information:	
Default Priority:	6	
Parameter Group Number:	65259 (0x00FEEB)	
<b>Start Position</b>	<b>Length</b>	<b>Parameter Name</b>
a	1-5 Byte	Make, Delimiter (ASCII “**”)
b	Variable	Model, Delimiter (ASCII “**”)
c	Variable	Serial Number, Delimiter (ASCII “**”)
d	Variable	Unit Number (Power Unit), Delimiter (ASCII “**”)
<b>SPN</b>		
		586
		587
		588
		233
(a)*(b)*(c)*(d)*(e)*		

## 4. ECU SETPOINTS ACCESSED WITH ELECTRONIC ASSISTANT

---

This section describes in detail each setpoint, and their default and ranges. Default values presented in tables are values used when setpoint in question is active. Many of the setpoints are dependent on other setpoints and they may not be active by default. Associated Figures show screen capture of initial operation, however some of the setpoints are not in default condition as they are set differently to activate more setpoints for the image. The setpoints are divided into setpoint groups as they are shown in EA. For more information on how each setpoint is used by 12 RTD Scanner, refer to the relevant section in this user manual.

### 4.1. Accessing the ECU Using EA

ECU with P/N AX184000 does not need any specific setup for EA. In order to access the high speed versions, AX184000-01 and/or AX184000-02, the CAN bus Baud Rate needs to be set accordingly. The CAN Interface Setup can be found from “Options” menu in EA.

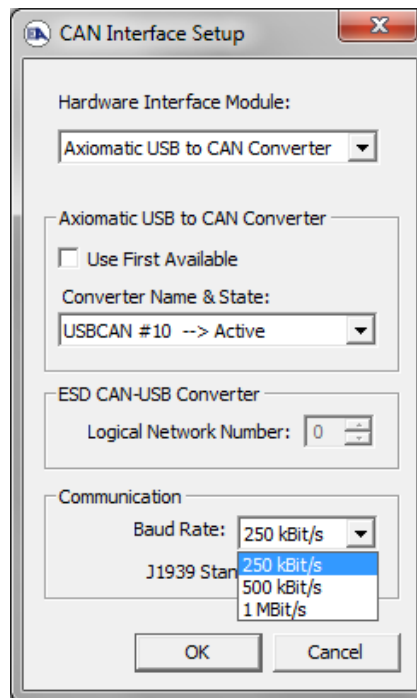

## 4.2. J1939 Network Parameters

“ECU Instance Number” and “ECU Address” setpoints and their effect are defined in Section 3.2.

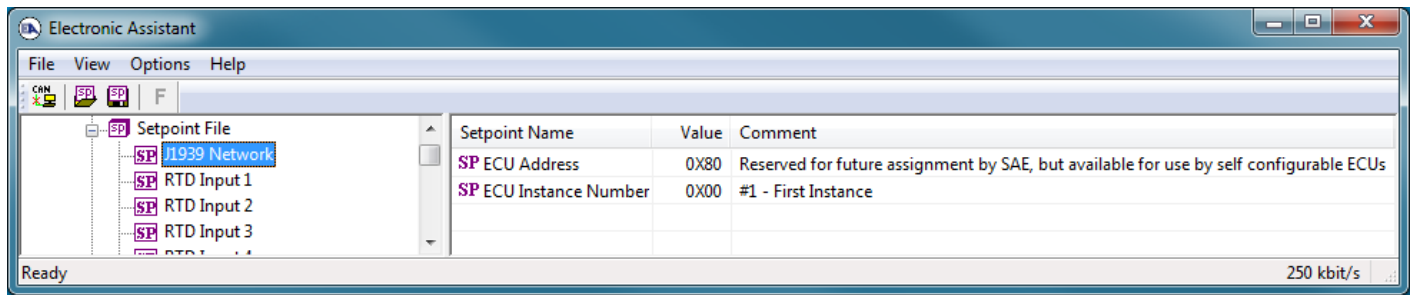

**Figure 6 - Screen Capture of J1939 Setpoints**

Name	Range	Default	Notes
ECU Address	0-253	0x80	Preferred address for a self-configurable ECU
ECU Instance	0x00	0-7	Per J1939-81

**Table 17 – J1939 Network Setpoints**

If non-default values for the “ECU Instance Number” or “ECU Address” are used, they will be mirrored during a setpoint file flashing, and will only take effect once the entire file has been downloaded to the unit. After the setpoint flashing is complete, the unit will claim the new address and/or re-claim the address with the new NAME. If these setpoints are changing, it is recommended to close and re-open the CAN connection on EA after the file is loaded so that only the new NAME and address are showing in the J1939 CAN Network ECU list.

### 4.3. RTD Input Setpoints

The RTD Inputs are defined in Section 1.1. Please refer there for detailed information how these setpoints are used.

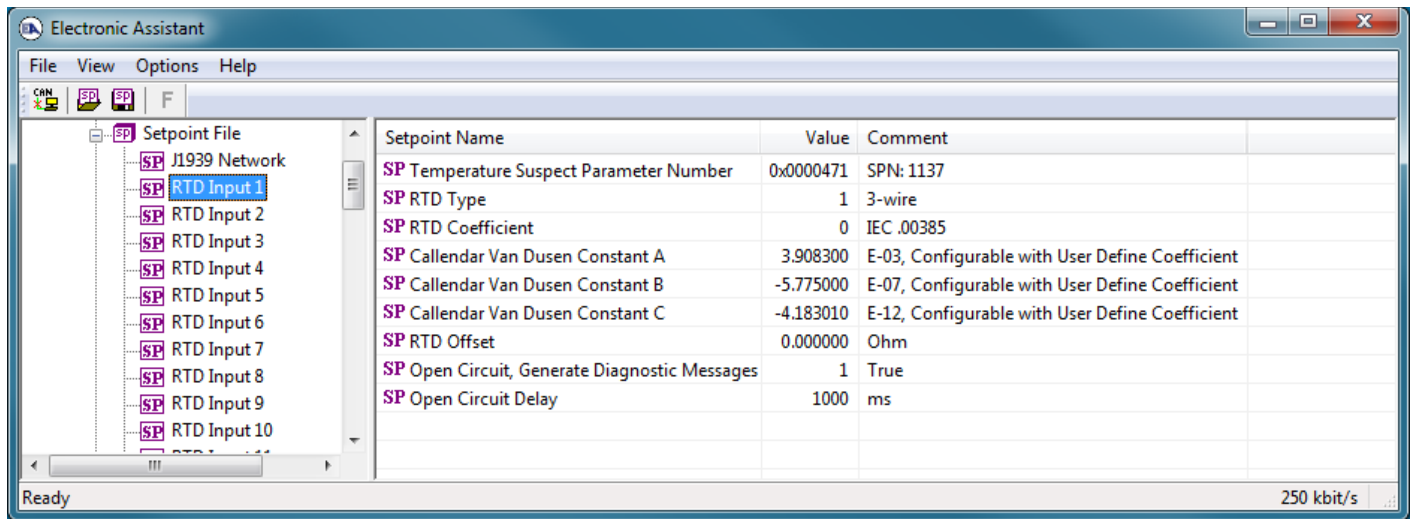

Figure 7 - Screen Capture of RTD Input Setpoints

Name	Range	Default	Notes
Temperature Suspect Parameter Number	Drop List		See Table 3
RTD Coefficient	Drop List	IEC 0.00385	See Table 1
Callendar Van Dusen Constant A	-10.000000 to 10.000000 E-03	3.908300 E-03	See Table 2
Callendar Van Dusen Constant B	-10.000000 to 10.000000 E-07	-5.77500 E-07	See Table 2
Callendar Van Dusen Constant C	-10.000000 to 10.000000 E-12	-4.183010 E-12	See Table 2
RTD Offset	-10.000000 to 10.000000	0.000000 Ohm	See Section 1.1
Open Circuit, Generate Diagnostic messages	False, True	True	See Section 1.1
Open Circuit Delay	0...60000 ms	1000ms	See Section 1.1

Table 18 – RTD Input Setpoints

### 4.4. Universal Input Setpoints

The Universal Inputs are defined in Section 1.3. Please refer there for detailed information how these setpoints are used

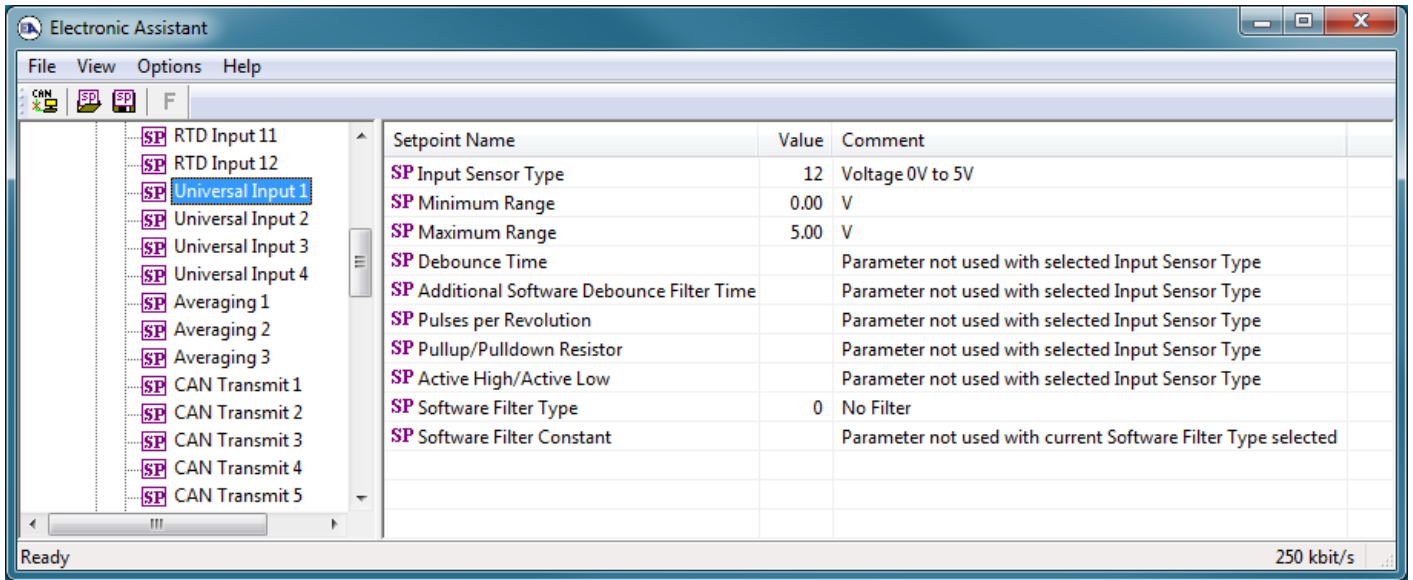

**Figure 8 - Screen Capture of Universal Input Setpoints**

Name	Range	Default	Notes
Input Sensor Type	Drop List	VOLTAGE_0_TO_5V	See Table 4
Minimum Range	From Minimum Error to Maximum Range	Depends on Input Sensor Type	
Maximum Range	From Minimum Range to Maximum Error	Depends on Input Sensor Type	
Debounce Time	Drop List	None	See Table 5
Additional Software Debounce Filter Time	Drop List	0ms	See Table 6
Pulses per Revolution	Drop List	FALSE	See Section 1.1
Pullup/Pulldown Resistor	Drop List	10kΩ Pulldown	See Table 7
Active High/Active Low	Drop List	Active High	See Table 8
Software Filter Type	Drop List	No Filtering	See Table 10
Software Filter Constant	1..1000	1	

**Table 19 – Universal Input Setpoints**

#### 4.5. Averaging Setpoints

The Averaging function blocks are defined in Section 1.2. Please refer there for detailed information how these setpoints are used.

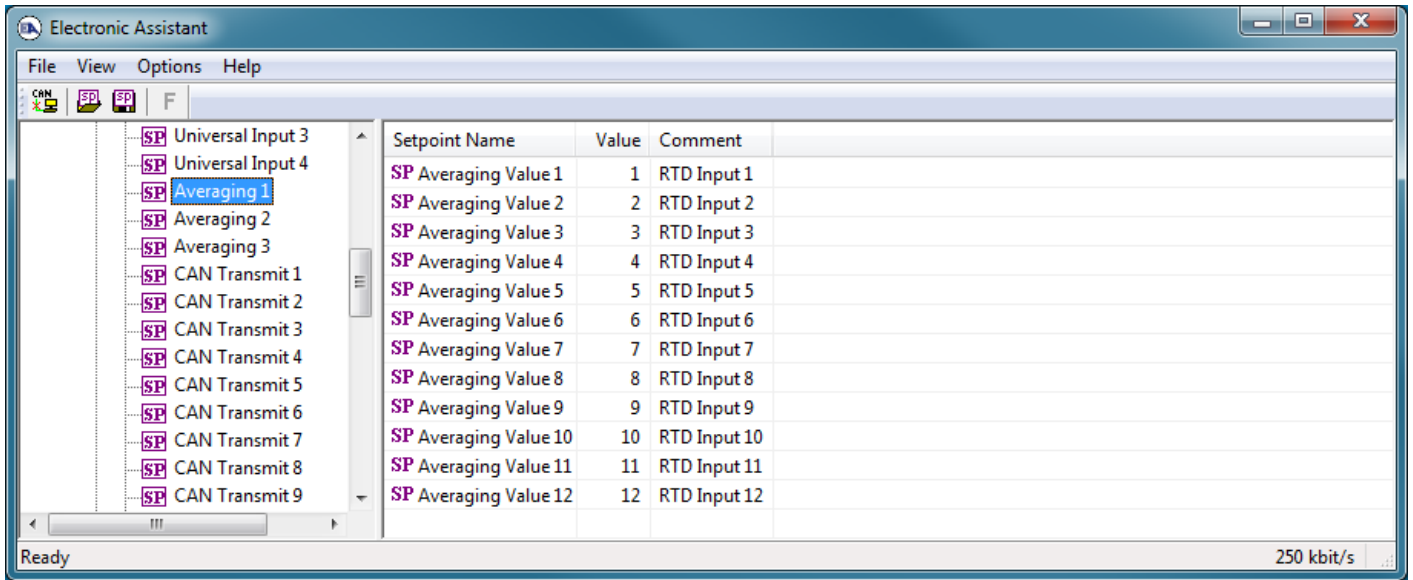

**Figure 9 - Screen Capture of Averaging Setpoints**

Name	Range	Default	Notes
Averaging Value 1	Drop List	RTD Input 1	
Averaging Value 2	Drop List	RTD Input 2	
Averaging Value 3	Drop List	RTD Input 3	
Averaging Value 4	Drop List	RTD Input 4	
Averaging Value 5	Drop List	RTD Input 5	
Averaging Value 6	Drop List	RTD Input 6	
Averaging Value 7	Drop List	RTD Input 7	
Averaging Value 8	Drop List	RTD Input 8	
Averaging Value 9	Drop List	RTD Input 9	
Averaging Value 10	Drop List	RTD Input 10	
Averaging Value 11	Drop List	RTD Input 11	
Averaging Value 12	Drop List	RTD Input 12	

**Table 20 – Averaging Setpoints**

#### 4.6. CAN Transmit Setpoints

CAN Transmit Message Function Block is presented in Section 1.6. Please refer there for detailed information how these setpoints are used. By default, CAN Transmit Messages 1 to 12 are associated with RTD inputs 1 to 12. And CAN Transmit Message 13 is set to produce PGN 64851 Engine Average message. Remaining three transmit messages utilize following defaults.

The screenshot shows the 'Electronic Assistant' software window. The left-hand pane displays a tree view of setpoint files under 'Setpoint File'. The 'CAN Transmit 1' setpoint is selected and highlighted. The right-hand pane shows a table of parameters for this setpoint.

Setpoint Name	Value	Comment
SP Transmit PGN	0xFE43	Transmit PGN: 65187
SP Transmit Repetition Rate	1000	ms
SP Transmit Message Priority	6	
SP Destination Address (PDU1)	255	Destination ECU Address: 0xFF
SP Signal 1 Data Source	2	RTD Input measured
SP Signal 1 Data Number	1	RTD Input measured #1
SP Signal 1 Transmit Data Size	5	Continuous 2-Bytes
SP Signal 1 Transmit Data Index in Array (LSB)	1	2nd Byte Position
SP Signal 1 Transmit Bit Index in Byte (LSB)		Parameter not used with current Data Size selected
SP Signal 1 Transmit Data Resolution	0.0312500	
SP Signal 1 Transmit Data Offset	-273.0000000	
SP Signal 1 Transmit Data Minimum	-273.0000000	
SP Signal 1 Transmit Data Maximum	1735.0000000	
SP Signal 2 Data Source	0	Control Not Used
SP Signal 2 Data Number		Parameter not used with current Data Source
SP Signal 2 Transmit Data Size		Parameter not used with current Data Source
SP Signal 2 Transmit Data Index in Array (LSB)		Parameter not used with current Data Source
SP Signal 2 Transmit Bit Index in Byte (LSB)		Parameter not used with current Data Source
SP Signal 2 Transmit Data Resolution		Parameter not used with current Data Source
SP Signal 2 Transmit Data Offset		Parameter not used with current Data Source
SP Signal 2 Transmit Data Minimum		Parameter not used with current Data Source
SP Signal 2 Transmit Data Maximum		Parameter not used with current Data Source
SP Signal 3 Data Source	0	Control Not Used
SP Signal 3 Data Number		Parameter not used with current Data Source
SP Signal 3 Transmit Data Size		Parameter not used with current Data Source
SP Signal 3 Transmit Data Index in Array (LSB)		Parameter not used with current Data Source
SP Signal 3 Transmit Bit Index in Byte (LSB)		Parameter not used with current Data Source
SP Signal 3 Transmit Data Resolution		Parameter not used with current Data Source
SP Signal 3 Transmit Data Offset		Parameter not used with current Data Source
SP Signal 3 Transmit Data Minimum		Parameter not used with current Data Source
SP Signal 3 Transmit Data Maximum		Parameter not used with current Data Source
SP Signal 4 Data Source	0	Control Not Used
SP Signal 4 Data Number		Parameter not used with current Data Source
SP Signal 4 Transmit Data Size		Parameter not used with current Data Source
SP Signal 4 Transmit Data Index in Array (LSB)		Parameter not used with current Data Source
SP Signal 4 Transmit Bit Index in Byte (LSB)		Parameter not used with current Data Source
SP Signal 4 Transmit Data Resolution		Parameter not used with current Data Source
SP Signal 4 Transmit Data Offset		Parameter not used with current Data Source
SP Signal 4 Transmit Data Minimum		Parameter not used with current Data Source
SP Signal 4 Transmit Data Maximum		Parameter not used with current Data Source

The status bar at the bottom indicates 'Ready' and a data rate of '250 kbit/s'.

**Figure 10 - Screen Capture of CAN Transmit Message Setpoints**

Name	Range	Default	Notes
Transmit PGN	0xff00 ... 0xffff	Different for each	See Section 1.6.1
Transmit Repetition Rate	0 ... 65000 ms	0ms	0ms disables transmit
Transmit Message Priority	0...7	6	Proprietary B Priority
Destination Address	0...255	255	Not used by default
Signal 1 Control Source	Drop List	Different for each	See Table 14
Signal 1 Control Number	Drop List	Different for each	See 1.6.2
Signal 1 Transmit Data Size	Drop List	2 bytes	
Signal 1 Transmit Data Index in Array	0-7	2	
Signal 1 Transmit Bit Index In Byte	0-7	0	
Signal 1 Transmit Data Resolution	-100000.0 to 100000	0.001	
Signal 1 Transmit Data Offset	-10000 to 10000	0.0	
Signal 1 Transmit Data Minimum	-1000000 to Max		
Signal 1 Transmit Data Maximum	-100000 to 100000		
Signal 2 Control Source	Drop List	Signal undefined	See Table 14
Signal 2 Control Number	Drop List	Signal undefined	See 1.6.2
Signal 2 Transmit Data Size	Drop List	2 bytes	
Signal 2 Transmit Data Index in Array	0-7	0	
Signal 2 Transmit Bit Index In Byte	0-7	0	
Signal 2 Transmit Data Resolution	-100000.0 to 100000	0.001	
Signal 2 Transmit Data Offset	-10000 to 10000	0.0	
Signal 2 Transmit Data Minimum	-1000000 to Max		
Signal 2 Transmit Data Maximum	-100000 to 100000		
Signal 3 Control Source	Drop List	Signal undefined	See Table 14
Signal 3 Control Number	Drop List	Signal undefined	See 1.6.2
Signal 3 Transmit Data Size	Drop List	2 bytes	
Signal 3 Transmit Data Index in Array	0-7	0	
Signal 3 Transmit Bit Index In Byte	0-7	0	
Signal 3 Transmit Data Resolution	-100000.0 to 100000	0.001	
Signal 3 Transmit Data Offset	-10000 to 10000	0.0	
Signal 3 Transmit Data Minimum	-1000000 to Max		
Signal 3 Transmit Data Maximum	-100000 to 100000		
Signal 4 Control Source	Drop List	Signal undefined	See Table 14
Signal 4 Control Number	Drop List	Signal undefined	See 1.6.2
Signal 4 Transmit Data Size	Drop List	2 bytes	
Signal 4 Transmit Data Index in Array	0-7	0	
Signal 4 Transmit Bit Index In Byte	0-7	0	
Signal 4 Transmit Data Resolution	-100000.0 to 100000	0.001	
Signal 4 Transmit Data Offset	-10000 to 10000	0.0	
Signal 4 Transmit Data Minimum	-1000000 to Max		
Signal 4 Transmit Data Maximum	-100000 to 100000		

**Table 21 – CAN Transmit Message Setpoints**

## 4.7. CAN Receive Setpoints

The Math Function Block is defined in Section 1.7. Please refer there for detailed information about how these setpoints are used. “**Receive Message Timeout**” is set to 0ms by default. To enable Receive message set “**Receive Message Timeout**” that differs from zero.

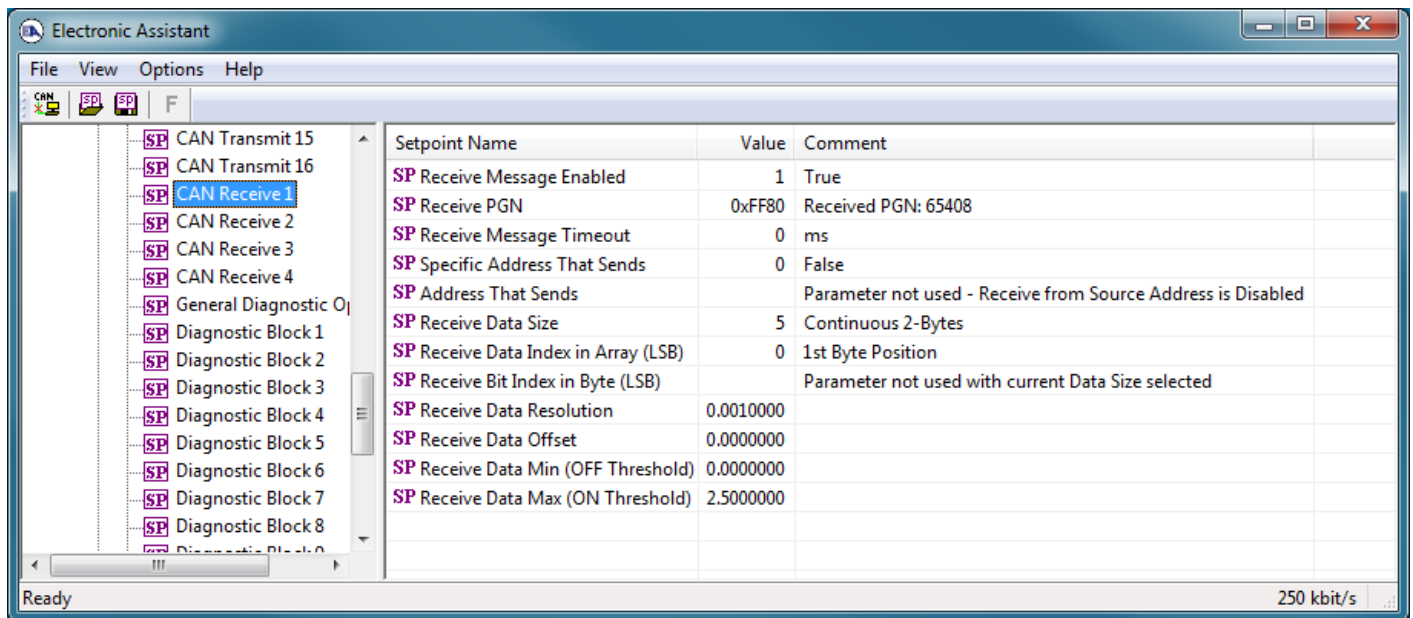

**Figure 11 - Screen Capture of CAN Receive Message Setpoints**

Name	Range	Default	Notes
Received Message Enabled	Drop List	False	
Received PGN	0 to 65536	Different for each	
Received Message Timeout	0 to 60 000 ms	0ms	
Specific Address that sends PGN	Drop List	False	
Address That Sends	0 to 255	254 (0xFE, Null Addr)	
Receive Transmit Data Size	Drop List	2 bytes	
Receive Transmit Data Index in Array	0-7	0	
Receive Transmit Bit Index In Byte	0-7	0	
Receive Transmit Data Resolution	-100000.0 to 100000	0.001	
Receive Transmit Data Offset	-10000 to 10000	0.0	
Receive Data Min (Off Threshold)	-1000000 to Max	0.0	
Receive Data Max (On Threshold)	-100000 to 100000	2.0	

**Table 22 – CAN Receive Setpoints**

#### 4.8. General Diagnostics Options

These setpoints control the shutdown of the ECU in case of a power supply or CPU temperature related errors. Refer to section 1.5 for more info.

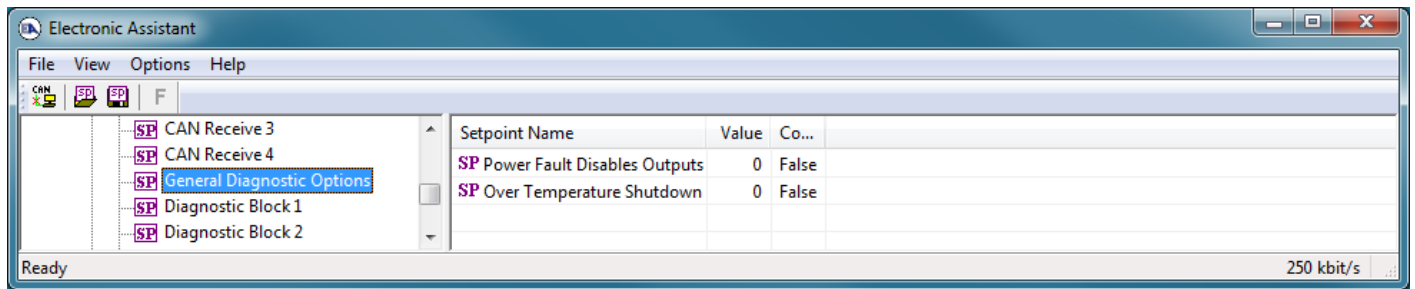

Figure 12 - Screen Capture of General Diagnostics Options Setpoints

<b>Name</b>	<b>Range</b>	<b>Default</b>	<b>Notes</b>
Power Fault Disables Outputs	Drop List	0	
Over Temperature Shutdown	Drop List	0	

**Table 23 – General Diagnostics Options Setpoints**

#### **4.9. Diagnostics Blocks**

There are 19 Diagnostics blocks that can be configured to monitor various parameters of the Controller. By default, the monitoring of operating voltage, CPU temperature and receive message timeouts is configured to diagnostics blocks 1, 2 and 3. Diagnostic blocks 4 to 15 are configured to monitor RTD inputs 1 to 12. The Diagnostic Function Block is defined in section 1.5. Please refer there for detailed information how these setpoints are used.

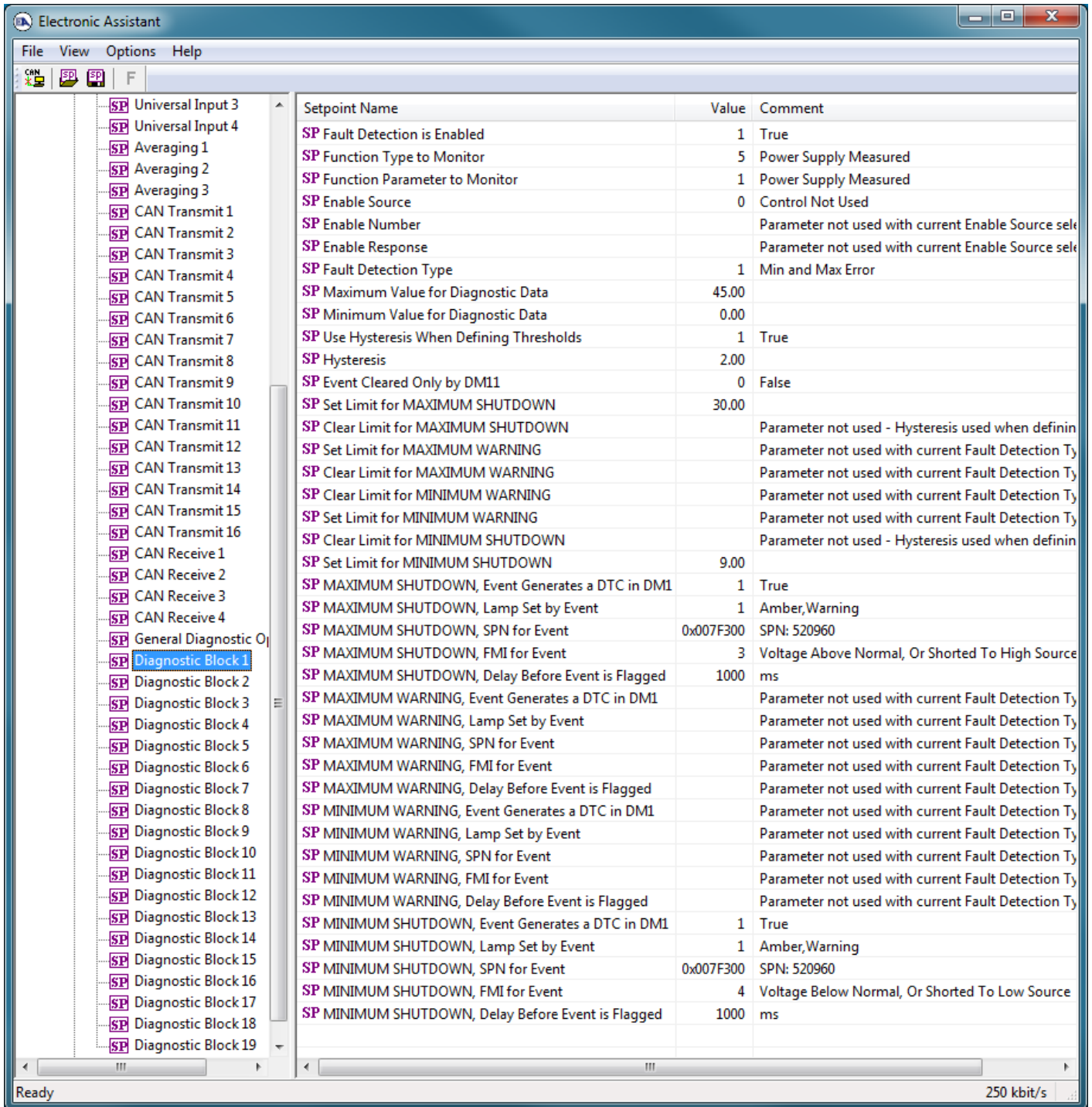

Figure 13 - Screen Capture of Diagnostic Block Setpoints

Name	Range	Default	Notes
Fault Detection is Enabled	Drop List	False	
Function Type to Monitor	Drop List	0 – Control not used	
Function parameter to Monitor	Drop List	0 – No selection	
Fault Detection Type	Drop List	1 – Min and Max Error	See section 1.5
Maximum Value for Diagnostic Data	Minimum Value for Diagnostic Data ... 4.28e <sup>9</sup>	5.0	
Minimum Value for Diagnostic Data	0.0 ... Maximum Value for Diagnostic Data	0.0	
Use Hysteresis When Defining Thresholds	Drop List	False	
Hysteresis	0.0 ... Maximum Value for Diagnostic Data	0.0	
Event Cleared only by DM11	Drop List	False	
Set Limit for MAXIMUM SHUTDOWN	Minimum Value for Diagnostic Data ... Maximum Value for Diagnostics Data	4.8	
Clear Limit for MAXIMUM SHUTDOWN	Minimum Value for Diagnostic Data ... Maximum Value for Diagnostics Data	4.6	
Set Limit for MAXIMUM WARNING	Minimum Value for Diagnostic Data ... Maximum Value for Diagnostics Data	0.0	
Clear Limit for MAXIMUM WARNING	Minimum Value for Diagnostic Data ... Maximum Value for Diagnostics Data	0.0	
Clear Limit for MINIMUM WARNING	Minimum Value for Diagnostic Data ... Maximum Value for Diagnostics Data	0.0	
Set Limit for MINIMUM WARNING	Minimum Value for Diagnostic Data ... Maximum Value for Diagnostics Data	0.0	
Clear Limit for MINIMUM SHUTDOWN	Minimum Value for Diagnostic Data ... Maximum Value for Diagnostics Data	0.4	
Set Limit for MINIMUM SHUTDOWN	Minimum Value for Diagnostic Data ... Maximum Value for Diagnostics Data	0.2	
MAXIMUM SHUTDOWN, Event Generates a DTC in DM1	Drop List	True	
MAXIMUM SHUTDOWN, Lamp Set by Event	Drop List	0 – Protect	See Table 11
MAXIMUM SHUTDOWN, SPN for Event	0...524287	520448 (\$7F100)	It is the user's responsibility to select an SPN that will not violate the J1939 standard.

MAXIMUM SHUTDOWN, FMI for Event	Drop List	3, Voltage Above Normal	See Table 12
MAXIMUM SHUTDOWN, Delay Before Event is Flagged	0...60000 ms	1000	
MAXIMUM WARNING, Event Generates a DTC in DM1	Drop List	True	
MAXIMUM WARNING, Lamp Set by Event	Drop List	0 – Protect	See Table 11
MAXIMUM WARNING, SPN for Event	0...524287	520704 (\$7F200)	It is the user's responsibility to select an SPN that will not violate the J1939 standard.
MAXIMUM WARNING, FMI for Event	Drop List	3, Voltage Above Normal	See Table 12
MAXIMUM WARNING, Delay Before Event is Flagged	0...60000 ms	1000	
MINIMUM WARNING, Event Generates a DTC in DM1	Drop List	True	
MINIMUM WARNING, Lamp Set by Event	Drop List	0 – Protect	See Table 11
MAXIMUM WARNING, SPN for Event	0...524287	520960 (\$7F300)	It is the user's responsibility to select an SPN that will not violate the J1939 standard.
MINIMUM WARNING, FMI for Event	Drop List	4, Voltage Below Normal	See Table 12
MINIMUM WARNING, Delay Before Event is Flagged	0...60000 ms	1000	
MINIMUM SHUTDOWN, Event Generates a DTC in DM1	Drop List	True	
MINIMUM SHUTDOWN, Lamp Set by Event	Drop List	Amber Warning	See Table 11
MINIMUM SHUTDOWN, SPN for Event	0...524287	521216 (\$7F400)	It is the user's responsibility to select an SPN that will not violate the J1939 standard.
MINIMUM SHUTDOWN, FMI for Event	Drop List	4, Voltage Below Normal	See Table 12
MINIMUM SHUTDOWN, Delay Before Event is Flagged	0...60000 ms	1000	

**Table 24 – Diagnostic Block Setpoints**

## 5. REFLASHING OVER CAN WITH EA BOOTLOADER

The AX184000 can be upgraded with new application firmware using the **Bootloader Information** section. This section details the simple step-by-step instructions to upload new firmware provided by Axiomatic onto the unit via CAN, without requiring it to be disconnected from the J1939 network.

*Note: To upgrade the firmware use Electronic Assistant ®  VX.X.XX.X or higher.*

1. When EA first connects to the ECU, the **Bootloader Information** section will display the following information.

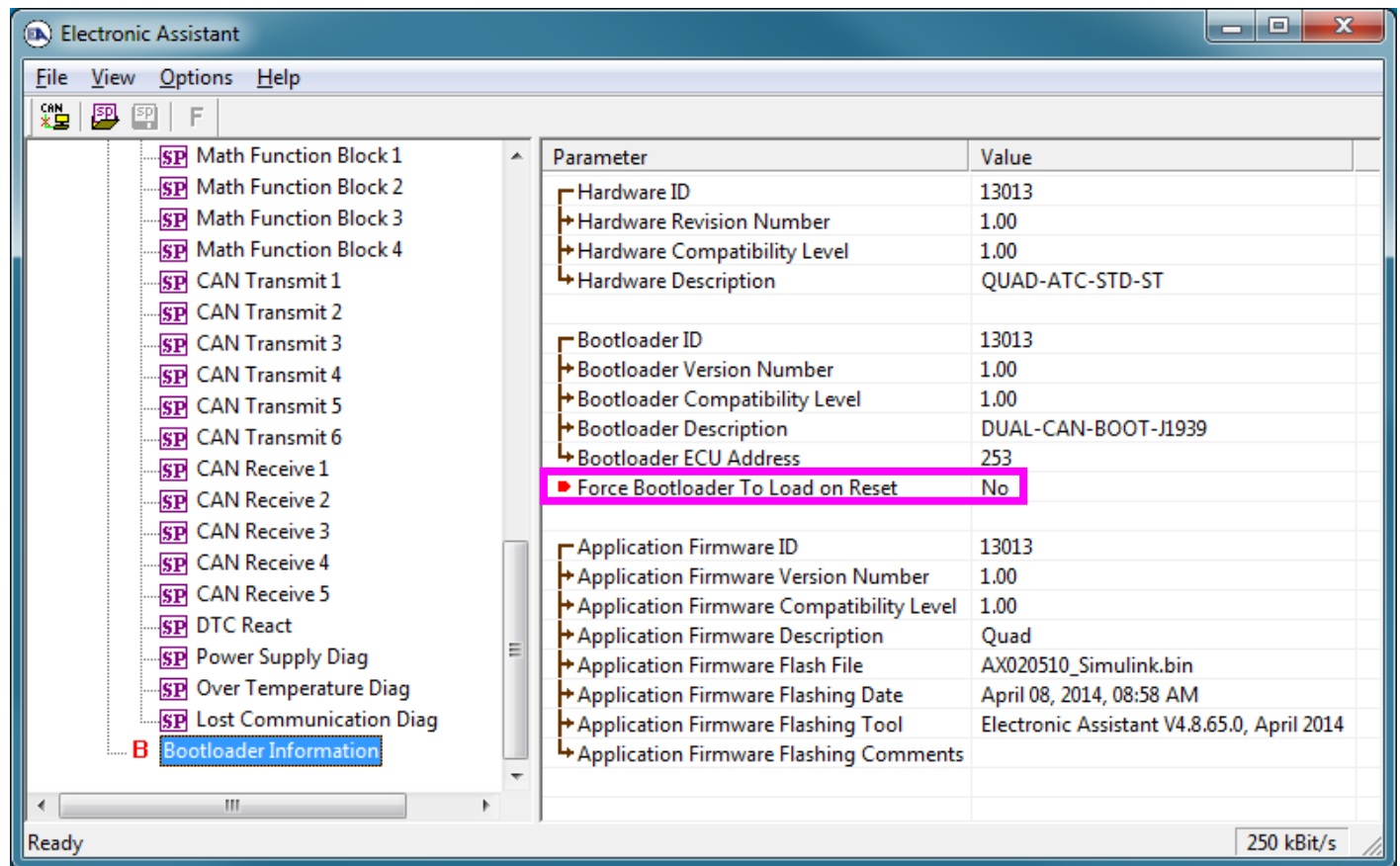

2. To use the bootloader to upgrade the firmware running on the ECU, change the variable “**Force Bootloader To Load on Reset**” to Yes.

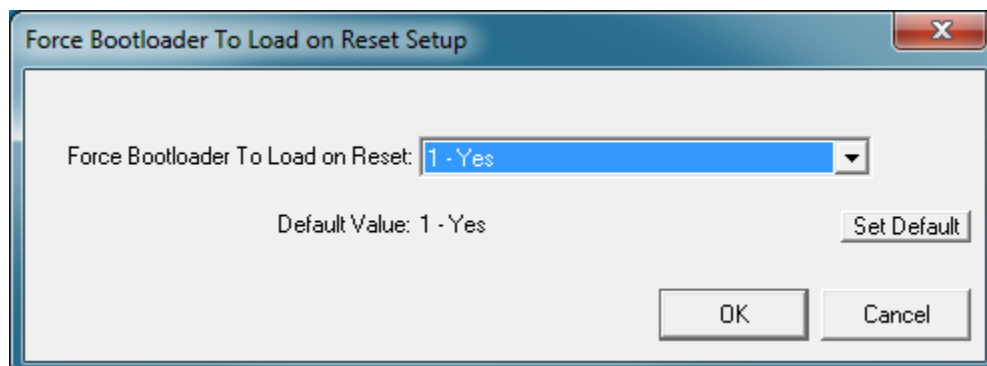

3. When the prompt box asks if you want to reset the ECU, select Yes.

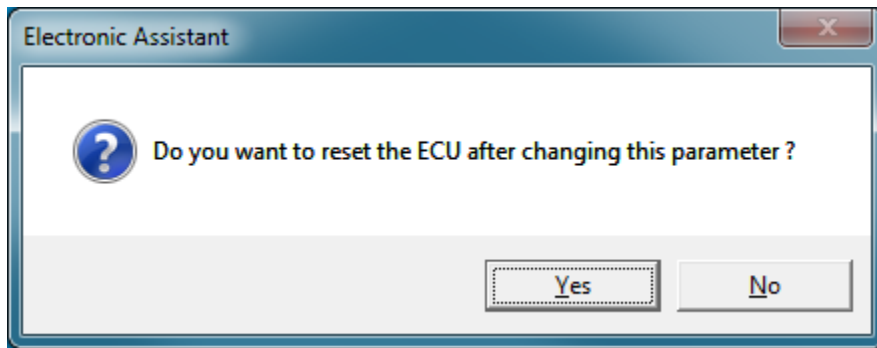

4. Upon reset, the ECU will no longer show up on the J1939 network as an AX184000 but rather as **J1939 Bootloader #1**.

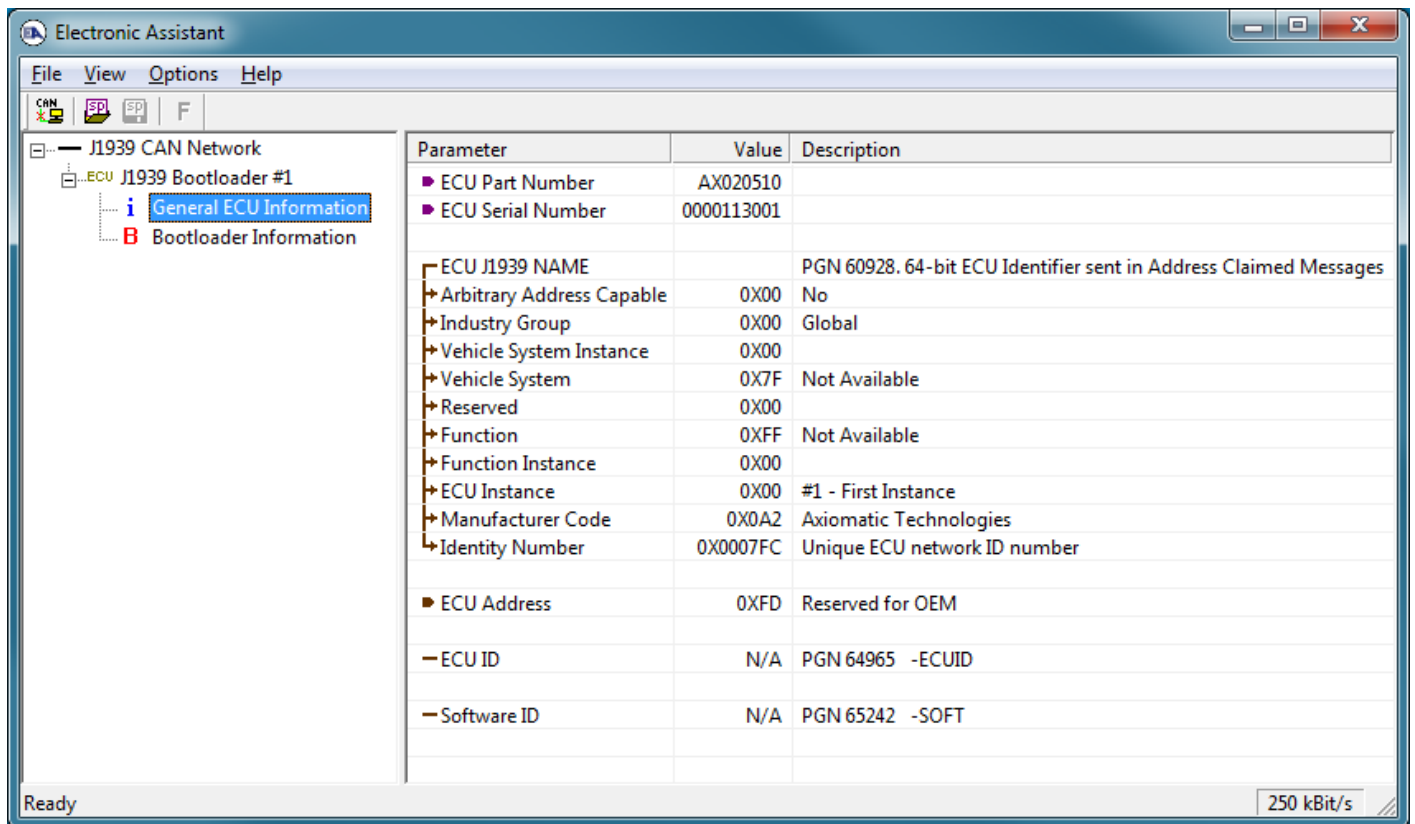
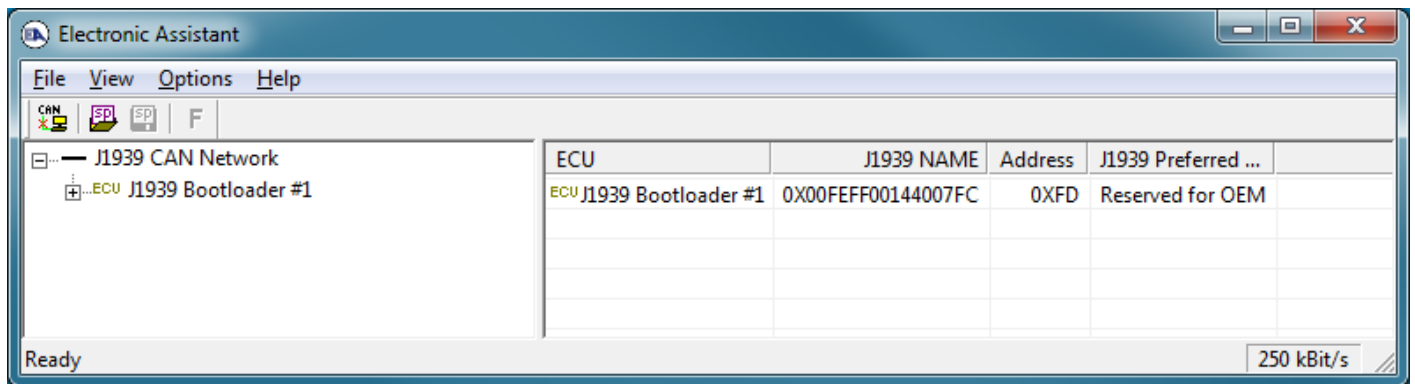

Note that the bootloader is NOT Arbitrary Address Capable. This means that if you want to have multiple bootloaders running simultaneously (not recommended) you would have to manually change the address for each one before activating the next, or there will be address conflicts. And only one ECU would show up as the bootloader. Once the 'active' bootloader returns to regular functionality, the other ECU(s) would have to be power cycled to re-activate the bootloader feature.

- When the **Bootloader Information** section is selected, the same information is shown as when it was running the AX184000 firmware, but in this case the **Flashing** feature has been enabled.

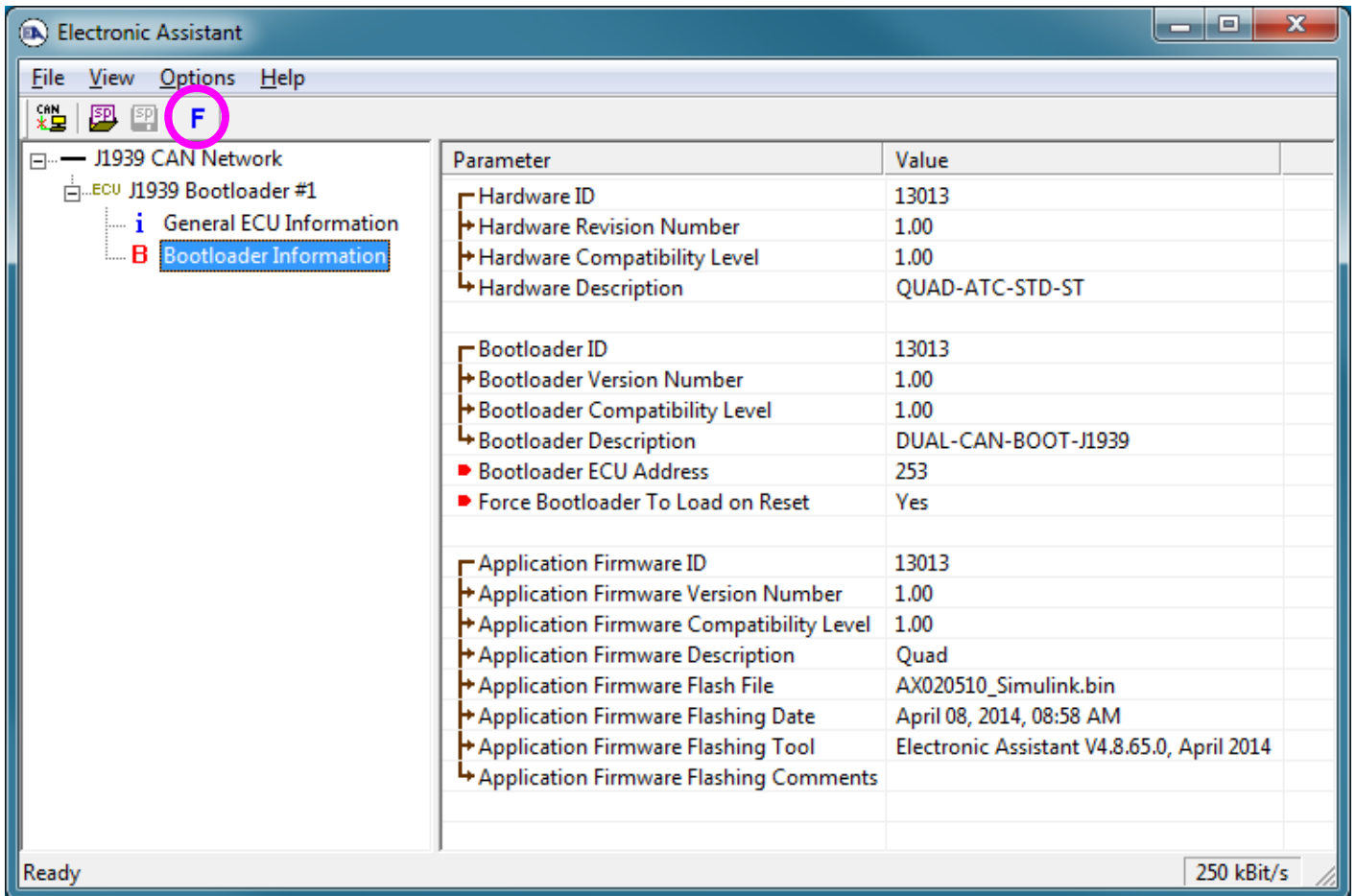

- Select the **Flashing** button and navigate to where you had saved the **AX184000\_Simulink.bin** file sent from Axiomatic. (Note: only binary (.bin) files can be flashed using the EA tool.)
- Once the Flash Application Firmware window opens, you can enter comments such as "Firmware upgraded by [Name]" if you so desire. This is not required, and you can leave the field blank if you do not want to use it.

Note: You do not have to date/time-stamp the file, as this is done automatically by the EA tool when you upload the new firmware.

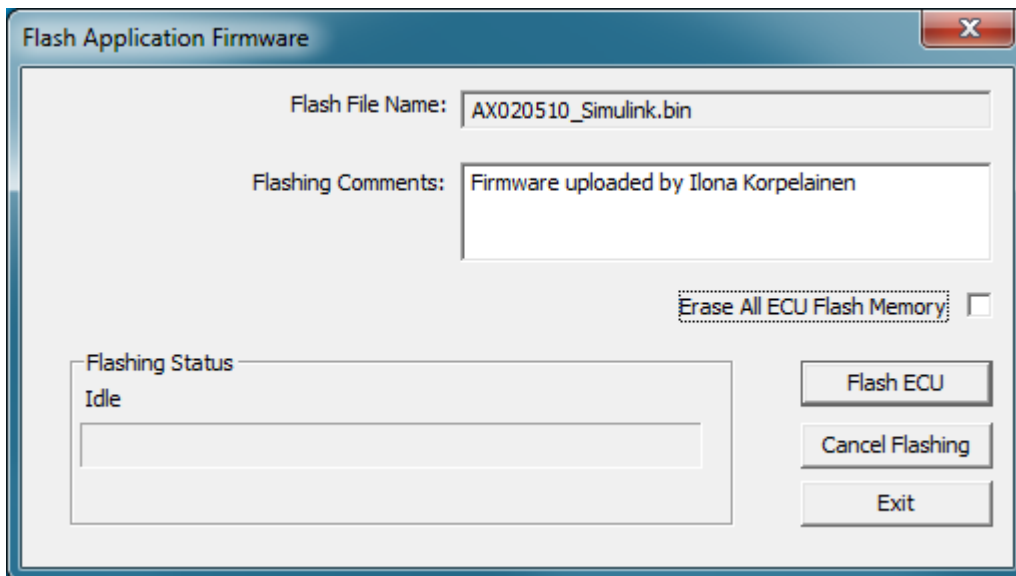

**WARNING:** Do not check the “Erase All ECU Flash Memory” box unless instructed to do so by your Axiomatic contact. Selecting this will erase ALL data stored in non-volatile flash including the calibration from Axiomatic factory testing. It will also erase any configuration of the setpoints that might have been done to the ECU and reset all setpoints to their factory defaults. By leaving this box unchecked, none of the setpoints will be changed when the new firmware is uploaded.

A progress bar will show how much of the firmware has been sent as the upload progresses. The more traffic there is on the J1939 network, the longer the upload process will take.

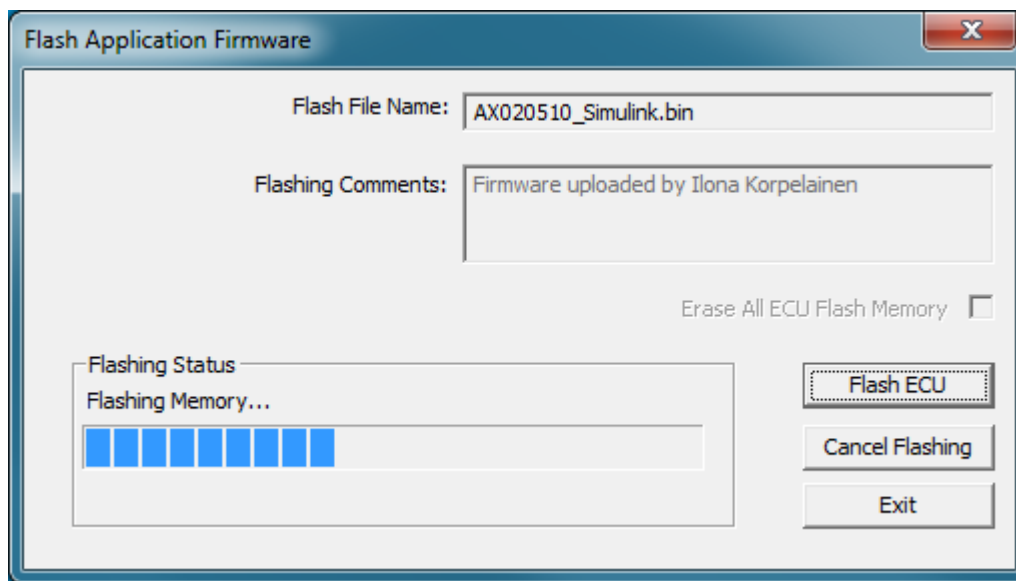

Once the firmware has finished uploading, a message will pop up indicating the successful operation. If you select to reset the ECU, the new version of the AX184000 application will start

running, and the ECU will be identified as such by EA. Otherwise, the next time the ECU is power-cycled, the AX184000 application will run rather than the bootloader function.

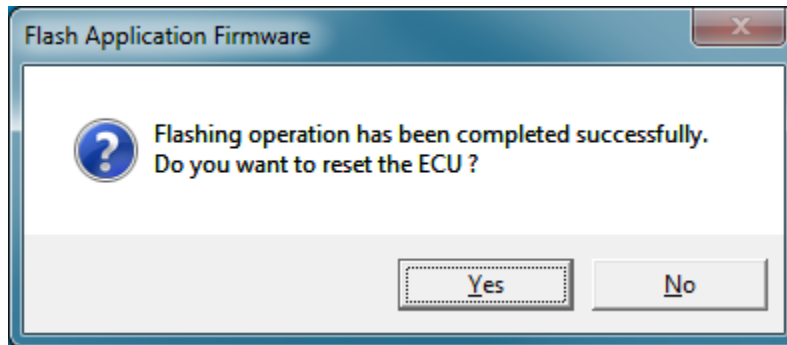

Note: If at any time during the upload the process is interrupted, the data is corrupted (bad checksum) or for any other reason the new firmware is not correct, i.e. bootloader detects that the file loaded was not designed to run on the hardware platform, the bad or corrupted application will not run. Rather, when the ECU is reset or power-cycled the **J1939 Bootloader** will continue to be the default application until valid firmware has been successfully uploaded into the unit.

## APPENDIX A - TECHNICAL SPECIFICATION

### Technical Specifications:

Specifications are indicative and subject to change. Actual performance will vary depending on the application and operating conditions. Users should satisfy themselves that the product is suitable for use in the intended application. All our products carry a limited warranty against defects in material and workmanship. Please refer to our Warranty, Application Approvals/Limitations and Return Materials Process as described on [www.axiomatic.com/service.html](http://www.axiomatic.com/service.html).

### Power and Protections

Power Supply Input	12V or 24VDC nominal (8...65 VDC power supply range) 50 or 60 Hz is user selectable.
Supply Current	90 mA at 12 Vdc Typical 45 mA at 24 Vdc Typical Inrush does not exceed 500 mA.
Protection	Reverse polarity protection is provided. Power supply input section protects against transients, surges (up to 175V) and short circuits and is isolated from RTD inputs

### RTD Inputs

RTD Types	Up to 12 channels, independently configurable for 2 or 3 wire RTDs. Each channel operates independently.
RTD Inputs	Each channel independently supports specific sensors IEC 0.00385, JIS 0.003916, US 0.003902, Legacy 0.003920, SAMA 0.003923. A user defined coefficient would enable custom Callendar-Van Dusen constants to be set for sensors not listed above. The device accepts inputs within the following range of 20 - 400 Ohms. RTD lead resistance range is 0 – 10 Ohms. Accuracy: +/- 1°C with offset calibration performed at R = 100 Ohms, typical at ambient temperature Resolution: 0.001°C Isolation voltage is 400V.
Shield	To connect a Shield, use the grounding stud provided on the base plate.
Scan Rate	50ms per channel, total sweep time maximum 50 ms 20 samples per second for all 12 channels
Common Mode Readings	Input range +/- 2V maximum Rejection is 115db at 5Vp-p (50-60Hz)
Thermal Drift	40 ppm/°C of span (maximum)
Isolation	Digital isolation is 500VDC from input to ground. Three-way isolation is provided for the CAN line, inputs and power supply

SPNs and PGNs	<p>The SPN drop list includes all temperature SPNs from the J1939-71 standard published up to January of 2009. If an SPN is not supported by the drop list, the user can select a zero SPN, which then allows them to define the SPN and PGN per the application requirements.</p> <p>One byte parameters have a resolution of 1 °C / bit and a range of -40 °C to 210 °C. Two byte parameters have resolution of 0.03125 °C / bit and a range of -273 °C to 1735 °C (per SAE J1939).</p> <p>The Parameter Group Number (PGN) that will be used to send a temperature to the J1939 network will be entirely dependent on the Suspect Parameter Number (SPN) that was selected for that channel. In all cases, the PGN is a PDU2 type. Each PGN has a predefined priority and repetition rate associate with it.</p>
Averaging	<p>The average temperature of all the active channels can be broadcasted to the network using the default “Engine Average Information” PGN, or on a Proprietary B message.</p>
Protection	<p>Open circuit detection  Frozen data detection  Over or under temperature detection  High temperature shutdown detection</p>

## Signal Inputs

Universal Inputs (4)	<p>Four universal inputs are user selectable as: voltage; current; PWM; or digital types. 12-bit Analog to Digital resolution. Protected against shorts to GND.</p> <p>Voltage Types: 0-5Vdc or 0-10Vdc 1mV resolution, accuracy +/- 1% error</p> <p>Current Types: 0-20 mA or 4-20 mA Current sense resistor 249Ω 1uA resolution, accuracy +/- 1% error</p> <p>Frequency: 0.5 to 50Hz or 10 Hz to 1 kHz or 100 Hz to 10 kHz Frequency Input: 0.01% resolution, accuracy +/- 1% error</p> <p>PWM Signal Frequency: 0 – 10,000 Hz PWM Duty Cycle: 0 to 100% PWM Input: 0.01% resolution, accuracy +/- 1% error</p> <p>Counter Counter Input: 0.01% resolution, accuracy +/- 1% error</p> <p>Digital Input: 1MΩ Impedance or Active High with 10K Pullup or Active Low with 10K Pulldown resistor to GND Amplitude: up to +Vsupply</p>
Analog Grounds	Four (4) analog ground connections are provided.

## Communications

CAN	<p>1 CAN 2.0B port, protocol SAE J1939 250 kbps Baud Rate Digital isolation is provided for the CAN line.</p>
Network Termination	<p>According to the CAN standard, it is necessary to terminate the network with external termination resistors. The resistors are 120 Ohm, 0.25W minimum, metal film or similar type. They should be placed between CAN_H and CAN_L terminals at both ends of the network.</p>

## General Specifications

Microprocessor	<p>STM32F205V 12-bit, 1 Mbyte Flash Memory</p>
----------------	--

Control Logic	<p>User programmable functionality with the Electronic Assistant®: Node address is auto configurable as per J1939-81 and/or via customer configuration.</p> <p>Monitored parameters and diagnostics are user selectable from a drop down list in the EA. Monitored parameters and diagnostics are read-only over the network</p> <p>All parameter locations have default values that do not conflict. Units are pre-configured with default values at the factory. Refer to the user manual.</p> <p>Parameter values and diagnostic error codes are retained when the modules are de-energized.</p> <p>Easily selectable SPNs from a drop down list of the temperature SPNs supported by SAE J1939.</p> <p>User defined SPN and PGN's configurable with Electronic Assistant® to suit the application.</p> <p>Configurable ECU Instance in the NAME to allow for multiple ECU's on the same network</p> <p>The bit-rate is 250 kbit/s. Other bit-rates (125 kbit/s, 500 kbit/s or 1 Mbit/s) can be factory programmed on request. Contact Axiomatic for an ordering p/n.</p> <p>Module is fully functional during configuration and communications.</p>
SAE J1939 Profile	<p>For J1939 compliance (SAE, Recommended Practice for a Serial Control and Communications Vehicle Network, October 2007) all modules comply with the applicable portions of the following:</p> <ul style="list-style-type: none"> <li>SAE J1939-21, December 2006, Data Link Layer</li> <li>SAE J1939-71, January 2009, Vehicle Application Layer</li> <li>SAE J1939-73, September 2006, Application Layer – Diagnostics</li> <li>SAE J1939-81, May 2003, Network Management</li> </ul> <p><i>Customer specific proprietary extensions can also be included in the SAE J1939 profile on request.</i></p>
Diagnostics	<p>Configurable Diagnostic Messaging parameters</p> <p>Diagnostic Log is maintained in non-volatile memory.</p> <p>Each RTD channel can be configured to send diagnostic messages to the network if the temperature goes out of range.</p>
User Interface	<p>Electronic Assistant®, P/N: AX070502</p> <p>Updates for the EA are found on <a href="http://www.axiomatic.com">www.axiomatic.com</a> under the log-in tab.</p>
UL and cUL Compliance	Pending
CE Compliance	<p>2004/108/EC (EMC Directive) pending</p> <p>2011/65/EU (RoHS Directive)</p>
Vibration	<p>MIL-STD-202G, Test 204D and 214A (Sine and Random)</p> <p>10 g peak (Sine); 7.86 Grms peak (Random)</p>
Shock	MIL-STD-202G, Test 213B, 50 g
Operating Temperature Range	-40 to 85 °C (-40 to 185 °F)

Storage Temperature Range	-50 to 120 °C (-58 to 248 °F)
Humidity	Protected against 95% humidity non-condensing, 30 °C to 60 °C
Protection	IP67
Weight	2.1 lb. (0.96 kg)
Enclosure	<p>Rugged aluminum housing, stainless steel end plates, neoprene gaskets</p> <p>145.30 x 149.00 x 73.00 mm (5.72 x 5.86 x 2.87") L x W x H</p> <p>Connectors, Deutsch IPD P/N: 1 8-pin DT13-08PA, 1 40-pin DRC13-40PX</p> <p>Can be mounted directly on the power generator set or remotely</p> <p>Suitable for moist, high shock, vibrating and non-hazardous environments</p> <p><i>Refer to the installation instructions section for pin out.</i></p>



## OUR PRODUCTS

Actuator Controls  
Automotive Ethernet Converters  
Battery Chargers  
CAN bus Controls  
CAN/Wifi, CAN/Bluetooth  
Current/Voltage Converters  
DC/DC Power Converters  
Engine Temperature Scanners  
Ethernet/CAN Converters, Switches  
Fan Drive Controllers  
Gateways, CAN/Modbus Protocols  
Gyroscope Inclinometers  
Hydraulic Valve Controllers  
Inclinometers, Triaxial  
I/O Controls  
LVDT Simulators  
Machine Controls  
Motor Controls  
Power Supplies  
PWM Signal Converters/Isolators  
Resolver Signal Conditioners  
Service Tools  
Signal Conditioners, Converters  
Strain Gauge CAN Controls  
Surge Suppressors

## OUR COMPANY

Axiomatic provides electronic machine controls, components, and systems to the off-highway, commercial vehicle, electric vehicle, power generator set, material handling, renewable energy and industrial OEM markets.

We provide efficient, innovative solutions that focus on adding value for our customers.

***We innovate with engineered and off-the-shelf machine controls.***

We emphasize service and partnership with our customers, suppliers, and employees to build long term relationships and mutual trust.

## QUALITY DESIGN AND MANUFACTURING

Axiomatic in Canada operates an ISO 9001:2015 registered design and manufacturing facility.

## SERVICE

All products to be returned to Axiomatic require a Return Materials Authorization Number (RMA#). Please request an RMA# from [rma@axiomatic.com](mailto:rma@axiomatic.com).

Please provide the following information when requesting an RMA number:

- Serial number, part number
- Axiomatic invoice number and date
- Hours of operation, description of problem
- Wiring set up diagram, application
- Other comments as needed

## WARRANTY, APPLICATION APPROVALS/LIMITATIONS

Axiomatic Technologies Corporation reserves the right to make corrections, modifications, enhancements, improvements, and other changes to its products and services at any time and to discontinue any product or service without notice. Customers should obtain the latest relevant information before placing orders and should verify that such information is current and complete. Users should satisfy themselves that the product is suitable for use in the intended application. All our products carry a limited warranty against defects in material and workmanship. Please refer to our Warranty, Application Approvals/Limitations and Return Materials Process as described on [www.axiomatic.com/service.html](http://www.axiomatic.com/service.html).

## CONTACTS

### Axiomatic Technologies Corporation

5915 Wallace Street  
Mississauga, ON  
CANADA L4Z 1Z8  
TEL: +1 905 602 9270  
FAX: +1 905 602 9279  
[www.axiomatic.com](http://www.axiomatic.com)

### Axiomatic Technologies Oy

Höytämöntie 6  
33880 Lempäälä  
FINLAND  
TEL: +358 103 375 750  
FAX: +358 3 3595 660  
[www.axiomatic.fi](http://www.axiomatic.fi)