

**4-CHANNEL  
STRAIN GAUGE CONTROLLER**  
With SAEJ1939®

**USER MANUAL**

**P/N: AX200300**

## ACCRONYMS

ACK	Positive Acknowledgement (from SAE J1939 standard)
SGIN	Strain Gauge Input
EA	Electronic Assistant <sup>®</sup> , p/n AX070502 (A Service Tool for Axiomatic ECUs)
ECU	Electronic Control Unit (from SAE J1939 standard)
NAK	Negative Acknowledgement (from SAE J1939 standard)
PDU1	A format for messages that are to be sent to a destination address, either specific or global (from SAE J1939 standard)
PDU2	A format used to send information that has been labeled using the Group Extension technique, and does not contain a destination address.
PGN	Parameter Group Number (from SAE J1939 standard)
PropA	Message that uses the Proprietary A PGN for peer-to-peer communication
PropB	Message that uses a Proprietary B PGN for broadcast communication
SPN	Suspect Parameter Number (from SAE J1939 standard)

# TABLE OF CONTENTS

<b>1. OVERVIEW OF CONTROLLER</b> .....	<b>5</b>
<b>1.1. DESCRIPTION OF 4-CHANNEL STRAIN GAUGE INPUT CONTROLLER</b> .....	<b>5</b>
<b>1.2. STRAIN GAUGE ADC FUNCTION BLOCK</b> .....	<b>8</b>
<b>1.3. STRAIN GAUGE INPUT FUNCTION BLOCK</b> .....	<b>8</b>
<b>1.4. TARE/CALIBRATION INPUT FUNCTION BLOCK</b> .....	<b>9</b>
1.4.1. Digital Input Setpoints .....	10
1.4.2. Tare/Calibrate Functionality .....	10
<b>1.5. INTERNAL FUNCTION BLOCK CONTROL SOURCES</b> .....	<b>12</b>
<b>1.6. DIGITAL / ANALOG &amp; INTERLOCK OUTPUTS FUNCTION BLOCKS</b> .....	<b>13</b>
1.6.1. Output Override .....	14
1.6.2. Output Enable .....	14
1.6.3. Output Control .....	15
1.6.4. Output Unlatch.....	16
<b>1.7. MISCELLANEOUS FUNCTION BLOCK</b> .....	<b>16</b>
<b>1.8. DIAGNOSTIC FUNCTION BLOCKS</b> .....	<b>16</b>
<b>1.9. MATH FUNCTION BLOCKS</b> .....	<b>18</b>
<b>1.10. PROGRAMMABLE LOGIC FUNCTION BLOCKS</b> .....	<b>20</b>
1.10.1. Conditions Evaluation .....	23
1.10.2. Table Selection .....	24
1.10.3. Logic Block Output .....	25
<b>1.11. LOOKUP TABLE FUNCTION BLOCK</b> .....	<b>25</b>
1.11.1. X-Axis, Input Data Response.....	26
1.11.2. Y-Axis, Lookup Table Output .....	26
1.11.3. Default Configuration, Data Response .....	26
1.11.4. Point To Point Response .....	27
1.11.5. X-Axis, Time Response.....	28
<b>1.12. SIMPLE CONDITIONAL LOGIC FUNCTION BLOCKS</b> .....	<b>28</b>
<b>1.13. SET / RESET LATCH FUNCTION BLOCKS</b> .....	<b>29</b>
<b>1.14. CAN TRANSMIT FUNCTION BLOCK</b> .....	<b>30</b>
<b>1.15. CAN TARE FUNCTION BLOCK</b> .....	<b>32</b>
<b>1.16. CAN RECEIVE FUNCTION BLOCK</b> .....	<b>32</b>
<b>2. INSTALLATION INSTRUCTIONS</b> .....	<b>34</b>
<b>2.1. DIMENSIONS AND PINOUT</b> .....	<b>34</b>
<b>2.2. MOUNTING INSTRUCTIONS</b> .....	<b>34</b>
2.2.1. Notes & Warnings .....	34
2.2.2. Mounting.....	35
2.2.3. Connections.....	35
<b>3. OVERVIEW OF J1939 FEATURES</b> .....	<b>36</b>
<b>3.1. INTRODUCTION TO SUPPORTED MESSAGES</b> .....	<b>36</b>
<b>3.2. NAME, ADDRESS AND SOFTWARE ID</b> .....	<b>37</b>
<b>3.3. CAN TRANSMIT MESSAGE DEFAULTS</b> .....	<b>38</b>
<b>4. ECU SETPOINTS ACCESSED WITH ELECTRONIC ASSISTANT</b> .....	<b>40</b>
<b>4.1. J1939 NETWORK SETPOINTS</b> .....	<b>40</b>
<b>4.2. STRAIN GAUGE ADC SETPOINTS</b> .....	<b>40</b>
<b>4.3. STRAIN GAUGE INPUT SETPOINTS</b> .....	<b>41</b>
<b>4.4. TARE BUTTON SETPOINTS</b> .....	<b>42</b>
<b>4.5. DIGITAL/ANALOG OUTPUT SETPOINTS</b> .....	<b>43</b>
<b>4.6. INTERLOCK/RELAY OUTPUT SETPOINTS</b> .....	<b>44</b>
<b>4.7. CONSTANT DATA LIST SETPOINTS</b> .....	<b>45</b>
<b>4.8. MISCELLANEOUS INPUT SETPOINTS</b> .....	<b>45</b>
<b>4.9. DIAGNOSTIC SETPOINTS</b> .....	<b>46</b>
<b>4.10. MATH FUNCTION SETPOINTS</b> .....	<b>47</b>
<b>4.11. PROGRAMMABLE LOGIC SETPOINTS</b> .....	<b>49</b>
<b>4.12. LOOKUP TABLE SETPOINTS</b> .....	<b>50</b>

- 4.13. **CONDITIONAL FUNCTION BLOCK SETPOINTS** ..... 51
- 4.14. **SET-RESET LATCH BLOCK** ..... 51
- 4.15. **CAN TRANSMIT SETPOINTS**..... 52
- 4.16. **CAN TARE SETPOINTS**..... 54
- 4.17. **CAN RECEIVE SETPOINTS**..... 54
  
- 5. **REFLASHING OVER CAN WITH EA ® BOOTLOADER** ..... 56
  
- 6. **TECHNICAL SPECIFICATIONS**..... 61
  - 6.1. **POWER SUPPLY** ..... 61
  - 6.2. **INPUTS**..... 61
  - 6.3. **OUTPUT** ..... 61
  - 6.4. **COMMUNICATION**..... 61
  - 6.5. **GENERAL SPECIFICATIONS** ..... 61
  
- 7. **VERSION HISTORY** ..... 63

# 1. OVERVIEW OF CONTROLLER

## 1.1. Description of 4-Channel Strain Gauge Input Controller

This User Manual describes the architecture and functionality of the 4-Channel Strain Gauge input controller.

The 4-Channel Strain Gauge Input Controller (4CH-SG) is designed for versatile control of up to 4 input channels to measure strain gauge load cells independently, Digital input for Tare/Calibration operations, 1 Digital/Analog output and 1 Interlock/Relay output. The sophisticated control algorithms allow the user to program the controller for a wide range of applications without the need for custom software.

There are 4 strain gauge input channels which can be configured to read any type of Load Cell with output ranges from +/-19mV to +/-2.5V to suit a wide variety of applications.

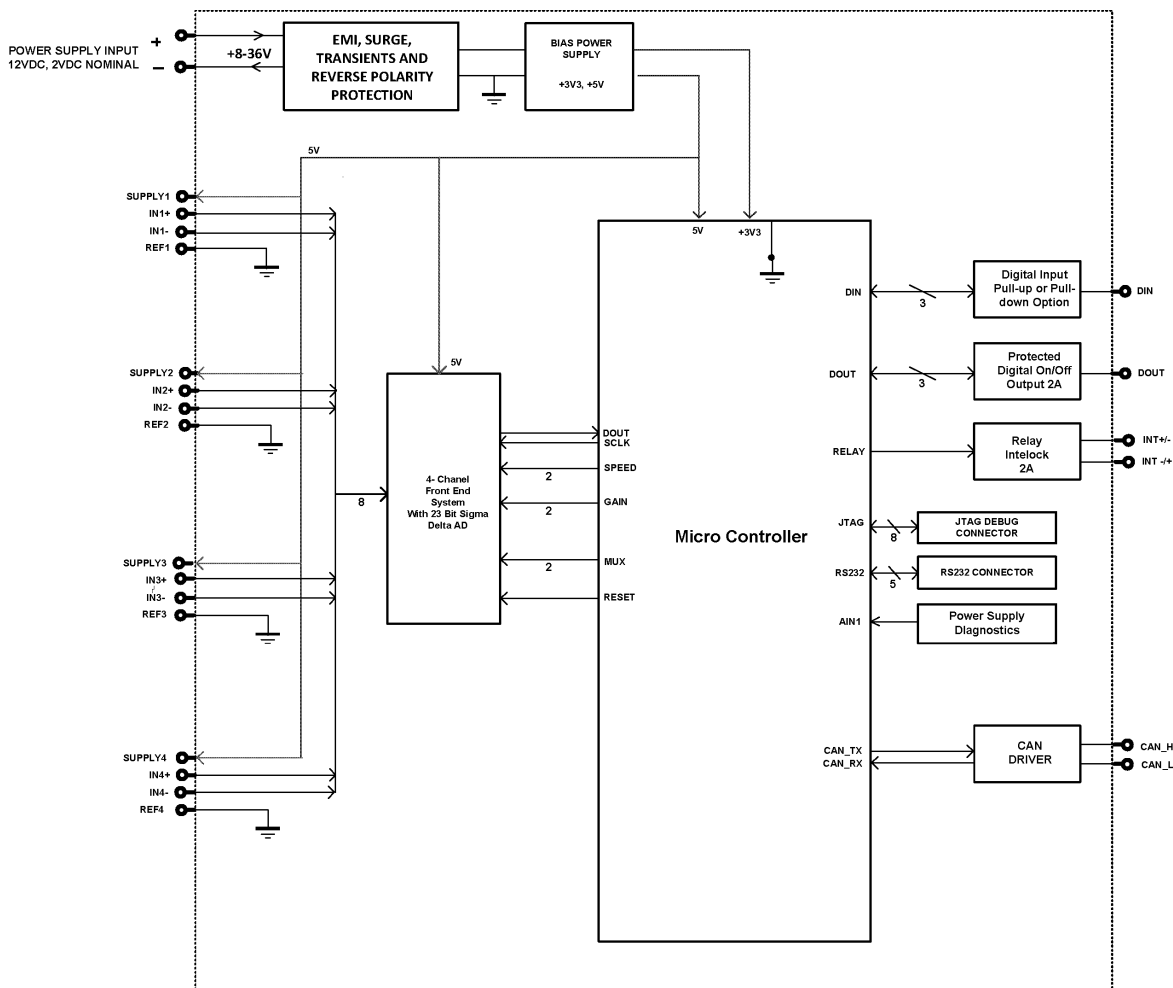

Figure 1 - Hardware Functional Block Diagram

The 4CH-SG is a highly configurable controller - allowing for custom configuration without the need of custom firmware. Its inputs, outputs, logical and mathematical function blocks allow the controller to support a wide variety of load cells to fit customer's various applications.

Each strain gauge input is periodically checked to see if its connection to the respective load cell has been disconnected or damaged. This process of checking for open wires is also configurable to suit various applications.

The 4CH-SG controller consists of a Digital Input, which is used for Tare/Calibration operations that are highly configurable in order to accommodate various users' applications. In cases where the digital input is not desired to be used as a Tare, the controller also allows to Tare the inputs via CAN messages or through Electronic Assistant (EA).

The controller also consists of an Interlock output and a Digital/Analog output. These can be used for signaling through an LED/lamp, driving an On/Off valve and/or as an interlock mechanism.

All inputs and logical function blocks on the unit are inherently independent from one another, but can be programmed to interact in a large number of ways. Figure 2 shows the hardware features of the 4CH-SG while Figure 1 shows the firmware features of the 4CH-SG.

The various function blocks supported by the 4CH-SG are outlined in the following sections. All setpoints are configurable using the Axiomatic service tool, Electronic Assistant .

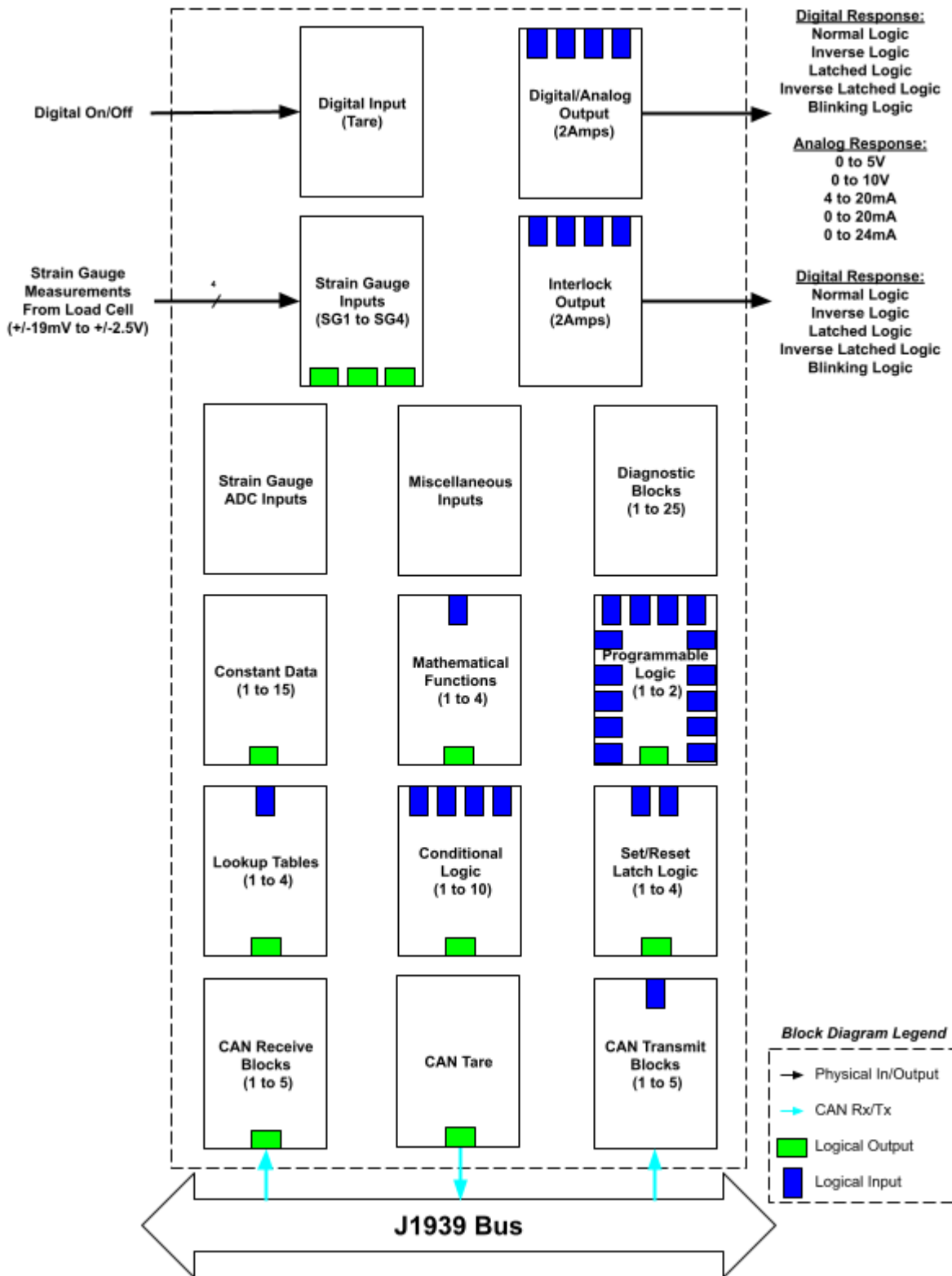

Figure 2 - Firmware Functional Block Diagram

### 1.2. Strain Gauge ADC Function Block

The Strain Gauge ADC function block is used to configure the general parameters of the Analog to Digital Converter which all strain gauge inputs are connected, and affecting how the data is read.

The “**Enable**” parameter is used to either enable or disable all conversions performed by the unit. While performing conversions there are several parameters that are used to influence how the data is processed and the effect of noise performance. The “**Digital Filter**” can be adjusted to use a low-pass ‘*SINC N*’ filter (programmable N of 1 through 5) or a finite input response filter, ‘*FIR*’. The finite response filter provides single-cycle settled data with simultaneous rejection of 50 and 60Hz frequencies. The “**Data Rate**” can also be selected as various values in the range of 2.5 to 40,000 samples per second (SPS). Additionally, the gain can be adjusted through the “**Gain Select**” setting, to values in the range of 1 to 128.

The final setting in this function block, the “**Burnout Time**” is used to configure the time period interval in between the unit entering its burnout mode to check for open wires across all strain gauge inputs. If this time is set to ‘0’ no open wire checking will occur. Reducing this interval will have a negative effect on the accuracy of the conversions.

### 1.3. Strain Gauge Input Function Block

The Strain Gauge Input (SGIn) function block is the logic associated with measuring and managing strain gauge inputs. The SGIn function block provides configurable parameters

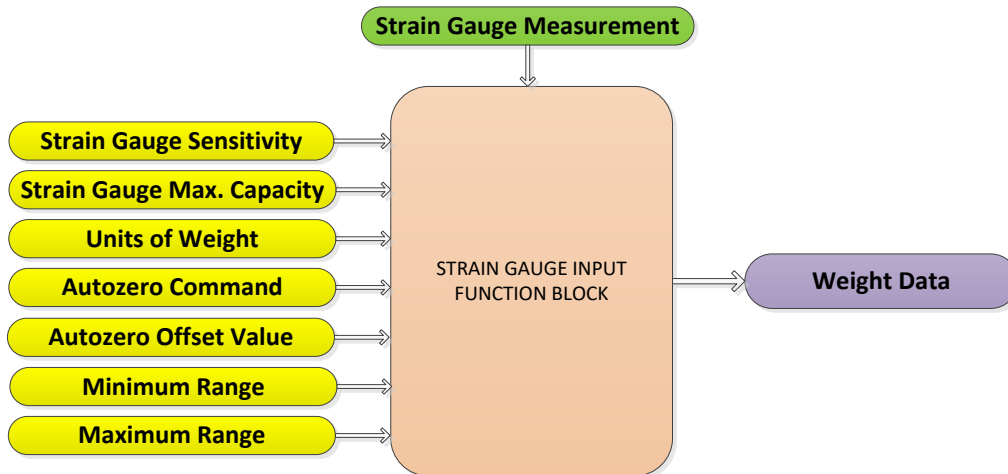

Figure 3 - Strain Gauge Input Function Block Diagram

The “**Strain Gauge Sensitivity**” parameter is the Strain Gauge Load Cell’s output voltage (in mV/V).

The “**Strain Gauge Maximum Capacity**” parameter is the maximum weight (in kilograms) the strain gauge can sense. With these two parameters, the 4CH-SG controller will modify its input measurements to determine the appropriate calculations based on the load cell’s entire output range.

When the required or desired measurements of weight need to be other than kg, “**Units of Weight**” parameter can be used to convert the measured weight in kg (by default) into pounds (lbs). This conversion of weight can be used in other functional blocks to compare to different weights.

Value	Meaning
0	Kilograms (kg)
1	Pounds (lbs)

Table 1 - Weight Conversion Options

Strain gauge load cells typically have an offset when installing. There may be weight added to the load cells, i.e. a platform which exerts weight onto the strain gauges. These offsets or extra added weight may be desired to become to 'zero-weight' position of the system. The 4CH-SG controller is continuously reading input data from strain gauge load cells. Another alternative to using the Tare button as explained in section 1.2, when the **"Autozero Command"** parameter is set to TRUE, the current measured weight (in kg or lbs) by the 4CH-SG will be considered the 'zero-weight' position. By doing this, **"Autozero Offset Value"** parameter will be automatically updated to the current weight position. Alternatively, the **"Autozero Offset Value"** parameter can be changed at any time.

#### 1.4. Tare/Calibration Input Function Block

The Tare/Calibration input function block can be used to zero the platform and measure and store minimum and maximum weights of the 4-strain gauge system. Figure 4 shows the parameters in the Tare Input Function Block:

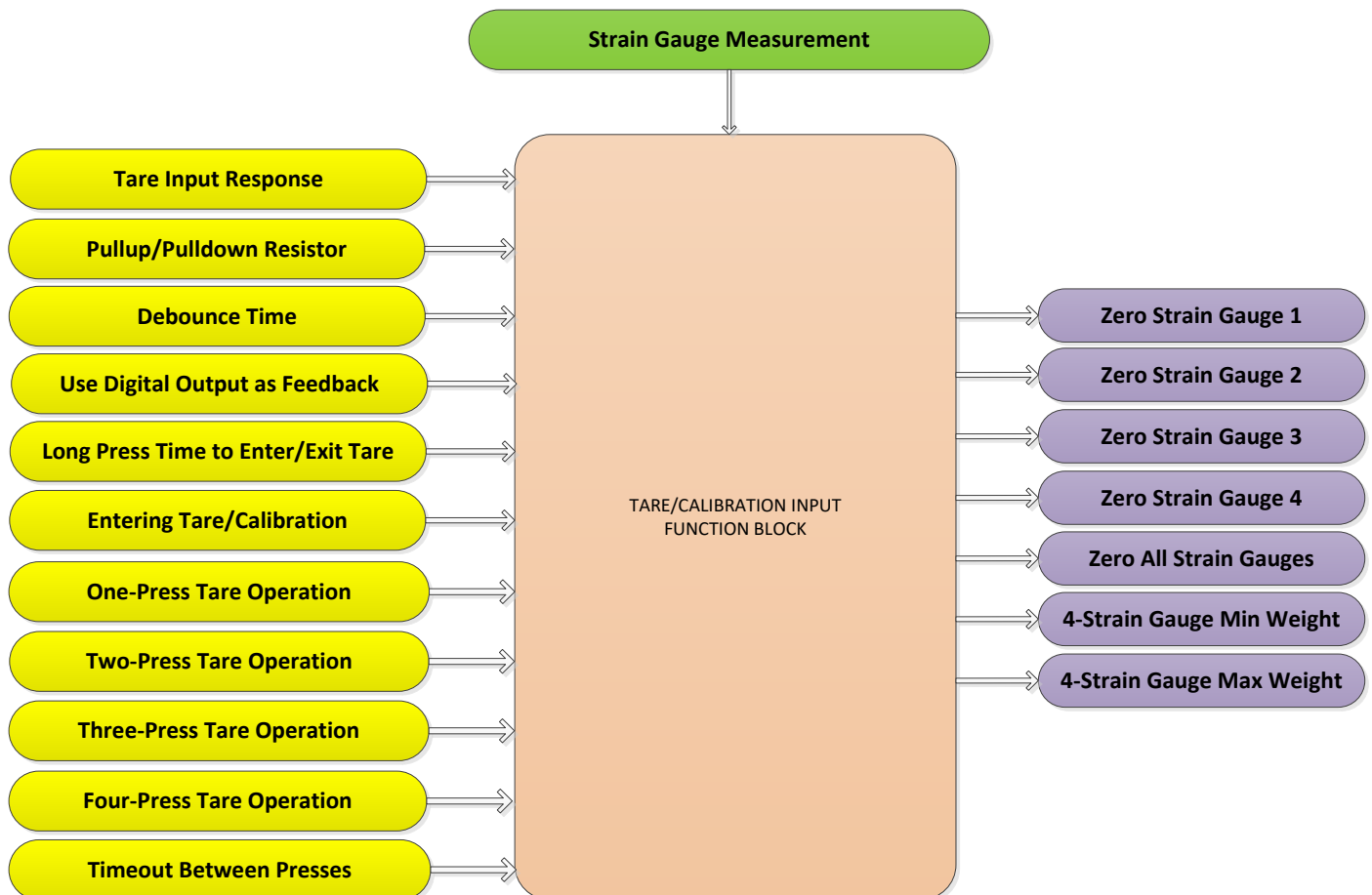

Figure 4 - Tare/Calibration Input Function Block Diagram

### 1.4.1. Digital Input Setpoints

“Tare Input Response” allows the user to select how the controller responds to the behaviour of the digital input. The signals going into the controller are interpreted as 0 or 1. The turn ON value (1) is reached at ~1V signal. Table 2 shows the different Tare Input Responses with the default response being highlighted.

Value	Meaning
<b>0</b>	<b>Normal On/Off</b>
1	Inverse Logic
2	Latched Logic
3	Inverse Latched Logic

Table 2 - Tare Input Response

22kOhm pull-up and 22kOhm pull-down resistors can be enabled or both can be disabled using the setpoint “Pullup/Pulldown Resistor”. Table 3 lists the available pull-up/pull-down resistor options with the default option highlighted.

Value	Meaning
<b>0</b>	<b>Pullup/Pulldown Off</b>
1	22kOhm pullup
2	22kOhm pulldown

Table 3 - Pull-up/Pull-down Resistor Options

The Debounce Time parameter is a useful parameter in cases where the digital input signal coming in to the controller is noisy. Figure 5 how the Debounce Time helps detect a correct input signal

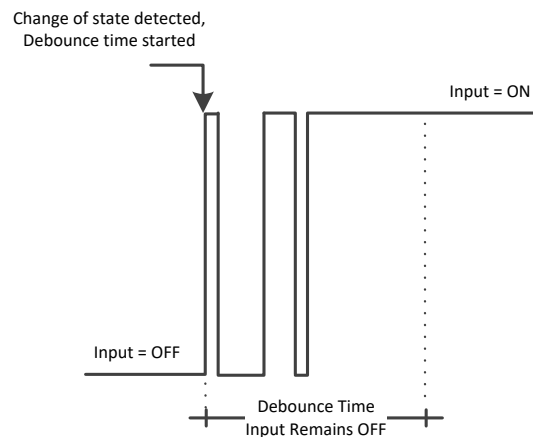

Figure 5 - Digital Input Debounce Time

### 1.4.2. Tare/Calibrate Functionality

When calibrating or zeroing the strain gauge inputs, the 4CH-SG offers a variety of options that can be performed with the use of a single Tare button. The “Use Digital Output as Feedback” setpoint gives the user the option of using one of the digital outputs as feedback to calibration steps. Table 4 lists the different feedback types that can be selected when Tare/Calibrating.

Value	Meaning
0	No Feedback Used

1	Digital Output
2	Interlock Output

Table 4 - Use Digital Output as Feedback Options

When using the Digital Output or the Interlock Output as feedback when calibrating, the following scenarios will occur:

- Outputs will not be commanded by their respective control sources
- The selected output will engage for 750ms when Entering Calibration
- The selected output will engage for 250ms corresponding to the Tare Operation number
- The selected output will engage for 750ms when Exiting Calibration
- Outputs will be commanded by their respective control sources after exiting calibration

#### 1.4.2.1. Entering/Exiting Calibration

In order to prevent ‘false calibration’ by pressing the Tare button by mistake, it is therefore necessary to enter calibration mode and exit calibration mode. “**Long Press Time to Enter/Exit Calibration**” setpoint is used to accomplish this function. Figure 6 explains the operation of entering and exiting calibration mode.

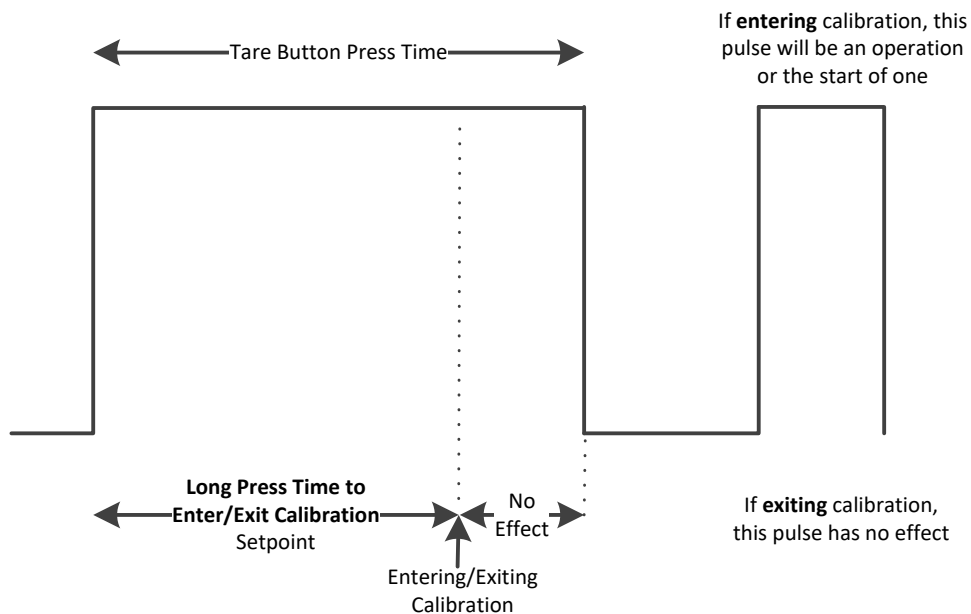

Figure 6 - Long Press to Enter/Exit Calibration Mode

As shown in Figure 6, the user can press the Tare button for much longer than the “**Long Press Time to Enter/Exit Calibration**” setpoint as it will have no effect on the calibration. When entering calibration, any Tare button press which has been pressed for shorter period of time than “**Long Press Time to Enter/Exit Calibration**” setpoint will be considered a Tare/Calibration operation. Refer to Section 1.4.2.2 for more details. On the other hand, when exiting calibration, any Tare button press which has been pressed for shorter period of time than “**Long Press Time to Enter/Exit Calibration**” will be ignored.



It is very important to exit calibration after the needed operations have been completed. Otherwise, the tare/calibration operations will not be saved.

### 1.4.2.2. Tare/Calibration Operations

After entering calibration mode the amount of consecutive presses will reflect the operation number. Consecutive presses are determined by parameter “**Timeout Between Presses**”. As long as the next Tare button press occurs before this parameter, the number of consecutive presses increases. Once the timeout occurs, the operation that will be executed will be determined by the count of consecutive presses before the timeout happened. Figure 7 provides a graphical explanation.

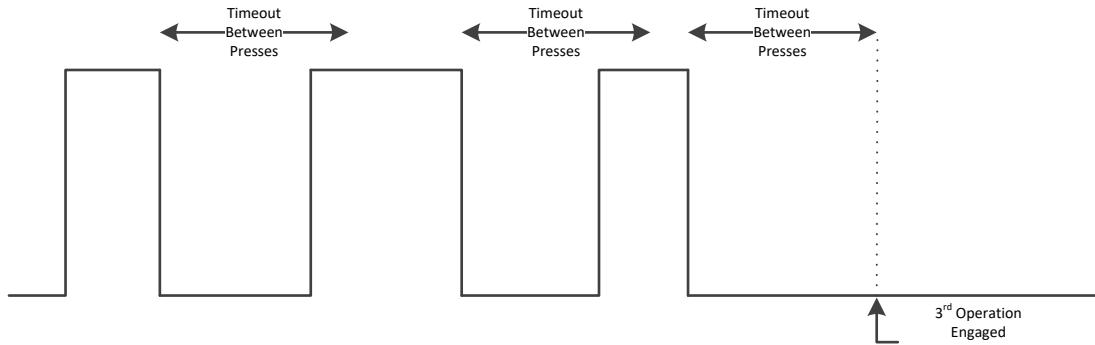

Figure 7 - Timeout Between Presses (Example)

The 4CH-SG allows up to 4 Tare/calibration operations that the user can perform. Table 5 lists all the available operations.

Value	Tare Operation
0	Operation Not Used
1	Zero Strain Gauge 1
2	Zero Strain Gauge 2
3	Zero Strain Gauge 3
4	Zero Strain Gauge 4
5	Zero All Strain Gauges
6	Set Overall Minimum Weight
7	Set Overall Maximum Weight

Table 5 - Tare Operations

When Tare Options 6 and 7 are used (‘Set Overall Minimum Weight’ and ‘Set Overall Maximum Weight’) as Tare/Calibration steps, their results - after exiting calibration mode - will be stored to Constant Data List 1 and Constant Data List 2, respectively. This allows the user to use those variables as inputs to other function blocks.

### 1.5. Internal Function Block Control Sources

The 4-Channel Strain Gauge controller allows for internal function block sources to be selected from the list of the logical function blocks supported by the controller. As a result, any output from one function block can be selected as the control source for another. Keep in mind that not all options make sense in all cases, but the complete list of control sources and their respective ranges is shown in Table 6.

Value	Meaning	Source Range
0	Control Not Used	[0]
1	Strain Gauge Input Raw Data	[1...4]
2	Strain Gauge Input mV Data	[1...4]
3	Strain Gauge Input Weight Data	[1...4]
4	CAN Tare Message	[1]
7	CAN Receive Message	[1...5]
8	Constant Data	[1...15]
9	Math Block	[1...4]
10	Programmable Logic Block	[1...2]
11	Lookup Table	[1...6]
12	Conditional Logic Block	[1...10]
13	Set-Reset Latch	[1...3]

Table 6 - Control Source Options

## 1.6. Digital / Analog & Interlock Outputs Function Blocks

The 4CH-SG supports a Digital/Analog Output as well as an Interlock Output. These outputs can be used for signaling, driving on/off valves, and interlocking – whichever the application may be. The Digital/Analog Output is capable of being configured as either a digital or analog output, but not both simultaneously.

The Digital and Interlock Outputs function similarly, but the Digital/Analog function block has additional parameters to select and control the output in Analog mode. The “**Output Type**” setting is used to determine whether the output is disabled or transmitted as a digital or analog output, as listed in Table 7.

Value	Meaning
0	Output Disabled
1	Digital Output
2	Voltage Output
3	Current Output

Table 7 - Digital/Analog Output Types

As an analog output, the additional parameters of “**Output Range**”, “**Slew Rate Control**”, “**Slew Rate Step Options**”, and “**Slew Rate Clock Options**” are used to configure the output. The “**Output Range**” values change according to the output type selected, as shown in Table 8.

Value	Meaning	
	Voltage Output	Current Output
0	0 to 5 V	4 to 20 mA
1	0 to 10 V	0 to 20 mA
2	-	0 to 24 mA

Table 8 - Analog Output Ranges

If “**Slew Rate Control**” is enabled, then the Step and Clock Options are used to program the slew rate of the output. While in an analog mode, the output is only controlled by the “**Control Source**” and corresponding number parameters, and scaled according to the settings of the input selected and the output range chosen.

The Digital and Interlock Outputs use various control sources to drive the output, each available from the listed sources in **Error! Reference source not found.** The output will be controlled by these sources in the following order: **“Override Source”**, **“Enable Source”**, **“Control Source”**, **“Unlatch Source”**. Each output must have at least the control source active to be functional.

The following sub sections will explain in more detail the functionalities and available setpoints/parameters.

### 1.6.1. Output Override

The **“Override Source”** will determine whether or not the output will be commanded by the **“Control Source”**. This Source has a higher priority than the Enable Source.

There are two different **“Override Responses”** in which the Override signal can be used. These responses are listed in Table 9, where the default value is highlighted.

Value	Meaning
0	Override When OFF
1	Override When ON

Table 9 - Override Responses

When the **“Override Response”** is configured to *Override When ON*, the output will be commanded according to the signal of the **“Control Source/Number”** by the **“Override State”**. If the Override Response is set to *Override When OFF*, the relay output will be commanded according to the signal of the Control Source/Number by the Override State. Table 10 shows the two possible states for the **“Override Response”**.

Value	Meaning
0	Override State OFF
1	Override State ON

Table 10 - Override States

In case of *‘Override State OFF’*, the output switches to Normally Open. If *‘Override State ON’* is configured, the output changes to Normally closed.

### 1.6.2. Output Enable

The **“Enable Source”** will determine whether or not the output will be commanded by the **“Control Source”**. There are six different **“Enable Responses”** in which the enable signal can be used. These responses are listed in Table 11, where the default value is highlighted.

Value	Meaning
0	Enable When ON
1	Enable When OFF
2	Disable When ON
3	Disable When OFF
4	Enable When ON Else Keep State
5	Enable When OFF Else Keep State

Table 11 - Enable Responses

When the “**Enable Response**” is set to ‘*Enable When ON*’ or ‘*Disable When OFF*’, the output will be commanded according to the signal of the “**Control Source/Number**” and the “**Logic Type**” only when the signal of the “**Enable Source/Number**” is ON. Otherwise, the output is commanded to the OFF state.

Similarly, when the “**Enable Response**” is set to ‘*Enable When OFF*’ or ‘*Disable When ON*’, the output will be commanded according to the “**Control Source/Number**” and the “**Logic Type**” only when the signal of the “**Enable Source/Number**” is OFF. Otherwise, the output is commanded to the OFF state.

In case the “**Enable Response**” is ‘*Enable When ON Else Keep State*’, the relay output will be commanded according to the signal of the “**Control Source/Number**” and the “**Logic Type**” only when the signal of the “**Enable Source/Number**” is ON. If the Enable Source is OFF, the output will keep the previous state.

Likewise, when the “**Enable Response**” is configured to ‘*Enable When OFF Else Keep State*’, the output will be commanded according to the “**Control Source/Number**” and the “**Logic Type**” only when the “**Enable Source/Number**” is OFF. Otherwise, the output holds the previous state.

A time delay for both states (ON, OFF) can be set by setting the “**Enable Response Delay**” parameter to true. The values of these time delays can be set with the parameters “**Turn OFF Delay**” and “**Turn ON Delay**”. In this case, the delays are valid for the enable state and the control state.

### 1.6.3. Output Control

When the output is being commanded by the “**Control Source**”, the selected “**Logic Type**” parameter determines what logic is used.

The “**Output Type**” parameter allows for flexibility in the response of the output. Table 12 shows the options available for this parameter.

Value	Meaning
0	Output Not Implemented
1	Normal Logic
2	Inverse Logic
3	Latched Logic
4	Inverse Latched Logic
5	Toggle Logic

Table 12 - Logic Types

By default, ‘*Normal Logic*’ response is used for the outputs.

In a ‘*Normal Logic*’ response, if the source of the respective output is triggered ON, the output state will be ON.

In the case of an ‘*Inverse Logic*’ response, when the source of the respective relay output is triggered OFF, the output state will be ON.

In the case of a *'Latched Logic'* response, every time the source of the respective output goes from OFF to ON, the output state will turn ON. The opposite behavior applies for the *'Inverse Latched Logic'*. If the output switches from ON to OFF, the output state changes.

The *'Toggle Logic'* lets the output toggle for a configured frequency. The time for switching from one state to the other state results the **"Toggle Frequency"** which is in milliseconds and by default 0ms.

#### 1.6.4. Output Unlatch

This source can only be configured if the **"Logic Type"** is set to *'Latched Logic'* or *'Inverse Latched Logic'*. If the state of the **"Unlatch Source"** is normally closed, it turns the output state OFF in case the **"Logic Type"** is set to *'Latched Logic'*. If the **"Unlatch Source"** state turns normally open afterwards, the output state stays OFF independent of the Output state before. The reverse behavior is valid for the *'Inverse Latched Logic'*.

#### 1.7. Miscellaneous Function Block

The Miscellaneous function block contains various parameters that affect the general diagnostic performance of the 4CH-SG.

The **"Undervoltage Threshold"**, **"Overvoltage Threshold"**, and **"Shutdown Temperature"** setpoints are used to set the limits for when their respective diagnostic messages are triggered.

Lastly, the **"CAN Diagnostic Setting"** parameter is used to control all diagnostics with one general setting for each CAN Interface independent of the other. This can be used to disable diagnostics entirely, only transmit messages without a blank SPN, or transmit diagnostic messages normally.

#### 1.8. Diagnostic Function Blocks

The Diagnostic function block includes twenty-five faults, each representing a diagnostic message that the 4CH-SG is able to produce.

If and only if the **"Event Generates a DTC in DM1"** parameter is set to true will the other setpoints in the function block be enabled. They are all related to the data that is sent to the J1939 network as part of the DM1 message, Active Diagnostic Trouble Codes.

A Diagnostic Trouble Code (DTC) is defined by the J1939 standard as a 4-byte value which is a combination of:

SPN	Suspect Parameter Number	(first 19 bits of the DTC, LSB first)
FMI	Failure Mode Identifier	(next 5 bits of the DTC)
CM	Conversion Method	(1 bit, always set to 0)
OC	Occurrence Count	(7 bits, number of times the fault has happened)

In addition to supporting the DM1 message, the Controller also supports

DM2	Previously Active Diagnostic Trouble Codes	<b>Sent only on request</b>
DM3	Diagnostic Data Clear/Reset of Previously Active DTCs	<b>Done only on request</b>
DM11	Diagnostic Data Clear/Reset for Active DTCs	<b>Done only on request</b>

So long as even one Diagnostic function block has “**Event Generates a DTC in DM1**” set to true, the Controller will send the DM1 message every one second, regardless of whether there are any active faults, as recommended by the standard. While there are no active DTCs, the Controller will send the “No Active Faults” message. If a previously active DTC becomes inactive, a DM1 will be sent immediately to reflect this. As soon as the last active DTC goes inactive, it will send a DM1 indicating that there are no more active DTCs.

If there is more than one active DTC at any given time, the regular DM1 message will be sent using a multipacket Broadcast Announce Message (BAM). If the controller receives a request for a DM1 while this is true, it will send the multipacket message to the Requester Address using the Transport Protocol (TP).



At power up, the DM1 message will not be broadcast until after a 5 second delay. This is done to prevent any power up or initialization conditions from being flagged as an active error on the network.

The Diagnostic function block has a setpoint “**Event Cleared Only by DM11**”. By default, this is set to false, which means that as soon as the condition that caused an error flag to be set goes away, the DTC is automatically made Previously Active, and is no longer included in the DM1 message. However, when this setpoint is set to true, even if the flag is cleared, the DTC will not be made inactive, so it will continue to be sent on the DM1 message. Only when a DM11 has been requested will the DTC go inactive. This feature may be useful in a system where a critical fault needs to be clearly identified as having happened, even if the conditions that caused it went away.

In addition to all the active DTCs, another part of the DM1 message is the first byte, which reflects the Lamp Status. Each Diagnostic function block has the setpoint “**Lamp Set by Event in DM1**” which determines which lamp will be set in this byte while the DTC is active. The J1939 standard defines the lamps as ‘Malfunction’, ‘Red Stop’, ‘Amber, Warning’ or ‘Protect’. By default, the ‘Amber, Warning’ lamp is typically the one set by any active fault.

By default, every Diagnostic function block has associated with it a proprietary SPN. However, this setpoint “**SPN for Event used in DTC**” is fully configurable by the user should they wish it to reflect a standard SPN define in J1939-71 instead. If the SPN is change, the OC of the associate error log is automatically reset to zero.

Every Diagnostic function block also has associated with it a default FMI. The only setpoint for the user to change the FMI is “**FMI for Event used in DTC**”, even though some Diagnostic function blocks can have both high and low errors. In those cases, the FMI in the setpoint reflects that of the low-end condition, and the FMI used by the high fault will be determined per Table 13. If the FMI is changed, the OC of the associate error log is automatically reset to zero.

<b>FMI for Event used in DTC – Low Fault</b>	<b>Corresponding FMI used in DTC – High Fault</b>
FMI=1, Data Valid But Below Normal Operational Range – Most Severe Level	FMI=0, Data Valid But Above Normal Operational Range – Most Severe Level
FMI=4, Voltage Below Normal, Or Shorted To Low Source	FMI=3, Voltage Above Normal, Or Shorted To High Source
FMI=5, Current Below Normal Or Open Circuit	FMI=6, Current Above Normal Or Grounded Circuit

FMI=17, Data Valid But Below Normal Operating Range – Least Severe Level	FMI=15, Data Valid But Above Normal Operating Range – Least Severe Level
FMI=18, Data Valid But Below Normal Operating Range – Moderately Severe Level	FMI=16, Data Valid But Above Normal Operating Range – Moderately Severe Level
FMI=21, Data Drifted Low	FMI=20, Data Drifted High

Table 13 - Low Fault FMI versus High Fault FMI



If the FMI used is anything other than one of those in Table 4, then both the low and the high faults will be assigned the same FMI. This condition should be avoided, as the log will still use different OC for the two types of faults, even though they will be reported the same in the DTC. It is the user's responsibility to make sure this does not happen.

When the fault is linked to a DTC, a non-volatile log of the occurrence count (OC) is kept. As soon as the controller detects a new (previously inactive) fault, it will start decrementing the “**Delay Before Sending DM1**” timer for the Diagnostic function block. If the fault has remained present during the delay time, then the controller will set the DTC to active, and it will increment the OC in the log. A DM1 will immediately be generated that includes the new DTC. The timer is provided so that intermittent faults do not overwhelm the network as the fault comes and goes, since a DM1 message would be sent every time the fault shows up or goes away.

### 1.9. Math Function Blocks

There are four mathematical function blocks that allow the user to define basic algorithms. A math function block can take up to four input signals. Each input is then scaled according to the associated limit and scaling setpoints.

Inputs are converted into percentage value based on the “**Function X Input Y Minimum**” and “**Function X Input Y Maximum**” values selected. For additional control the user can also adjust the “**Function X Input Y Scaler**”. By default, each input has a scaling ‘weight’ of 1.0 However, each input can be scaled from -1.0 to 1.0 as necessary before it is applied in the function.

A mathematical function block includes three selectable functions, which each implements equation  $A \text{ operator } B$ , where A and B are function inputs and operator is function selected with setpoint “**Math function X Operator**”. Setpoint options are presented in Table 14. The functions are connected together, so that result of the preceding function goes into Input A of the next function. Thus Function 1 has both Input A and Input B selectable with setpoints, where Functions 2 to 4 have only Input B selectable. Input is selected by setting “**Function X Input Y Source**” and “**Function X Input Y Number**”. If “**Function X Input B Source**” is set to 0 ‘Control not used’ signal goes through function unchanged.

$$\text{Math Block Output} = (((A1 \text{ op1 } B1) \text{ op2 } B2) \text{ op3 } B3) \text{ op4 } B4$$

0	=, True when InA equals InB
1	!=, True when InA not equal InB
2	>, True when InA greater than InB
3	>=, True when InA greater than or equal InB
4	<, True when InA less than InB
5	<=, True when InA less than or equal InB

6	OR, True when InA or InB is True
7	AND, True when InA and InB are True
8	XOR, True when either InA or InB is True, but not both
9	+, Result = InA plus InB
10	-, Result = InA minus InB
11	x, Result = InA times InB
12	/, Result = InA divided by InB
13	MIN, Result = Smallest of InA and InB
14	MAX, Result = Largest of InA and InB
15	MAX-MIN, Result = Absolute value of (InA – InB)

*Table 14 - Math Function Operators*

User should make sure the inputs are compatible with each other when using some of the Mathematical Operations. For instance, if Strain Gauge Input 1 is to be measured in [kg], while Strain Gauge Input 2 is to be measured in [lbs] and Math Function Operator 9 (+), the result will not be the true weight of the system.

For a valid result, the control source for an input must be a non-zero value, i.e. something other than 'Control Source Not Used.'

When dividing, a zero InB value will always result is a zero-output value for the associated function. When subtracting, a negative result will always be treated as a zero, unless the function is multiplied by a negative one, or the inputs are scaled with a negative coefficient first.

## 1.10. Programmable Logic Function Blocks

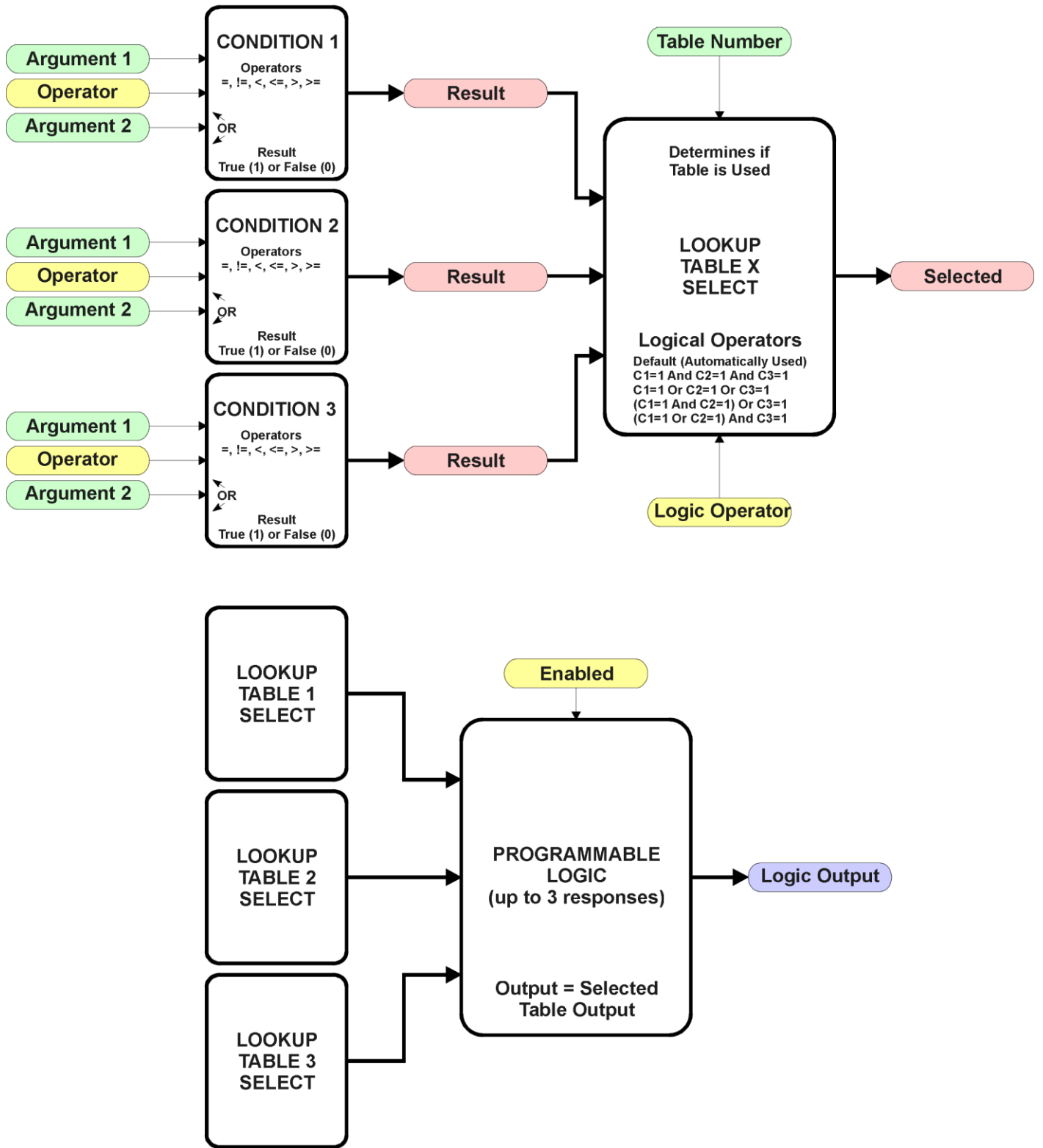

Figure 8 - Programmable Logic Function Block

This function block is obviously the most complicated of them all, but very powerful. The Programmable Logic can be linked to up to three tables, any one of which would be selected only under given conditions. Any three tables (of the available 8) can be associated with the logic, and which ones are used is fully configurable.

Should the conditions be such that a particular table (1, 2 or 3) has been selected as described in Section 1.10.2, then the output from the selected table, at any given time, will be passed directly to the Logic Output.

Therefore, up to three different responses to the same input, or three different responses to different inputs, can become the input to another function block, such as an Output X Drive. To do this, the **“Control Source”** for the reactive block would be selected to be the *‘Programmable Logic Function Block.’*

In order to enable any one of Programmable Logic blocks, the **“Programmable Logic Block Enabled”** setpoint must be set to True. They are all disabled by default.

Logic is evaluated in the order shown in Figure 9. Only if a lower number table has not been selected will the conditions for the next table be looked at. **The default table is always selected as soon as it is evaluated. It is therefore required that the default table always be the highest number in any configuration.**

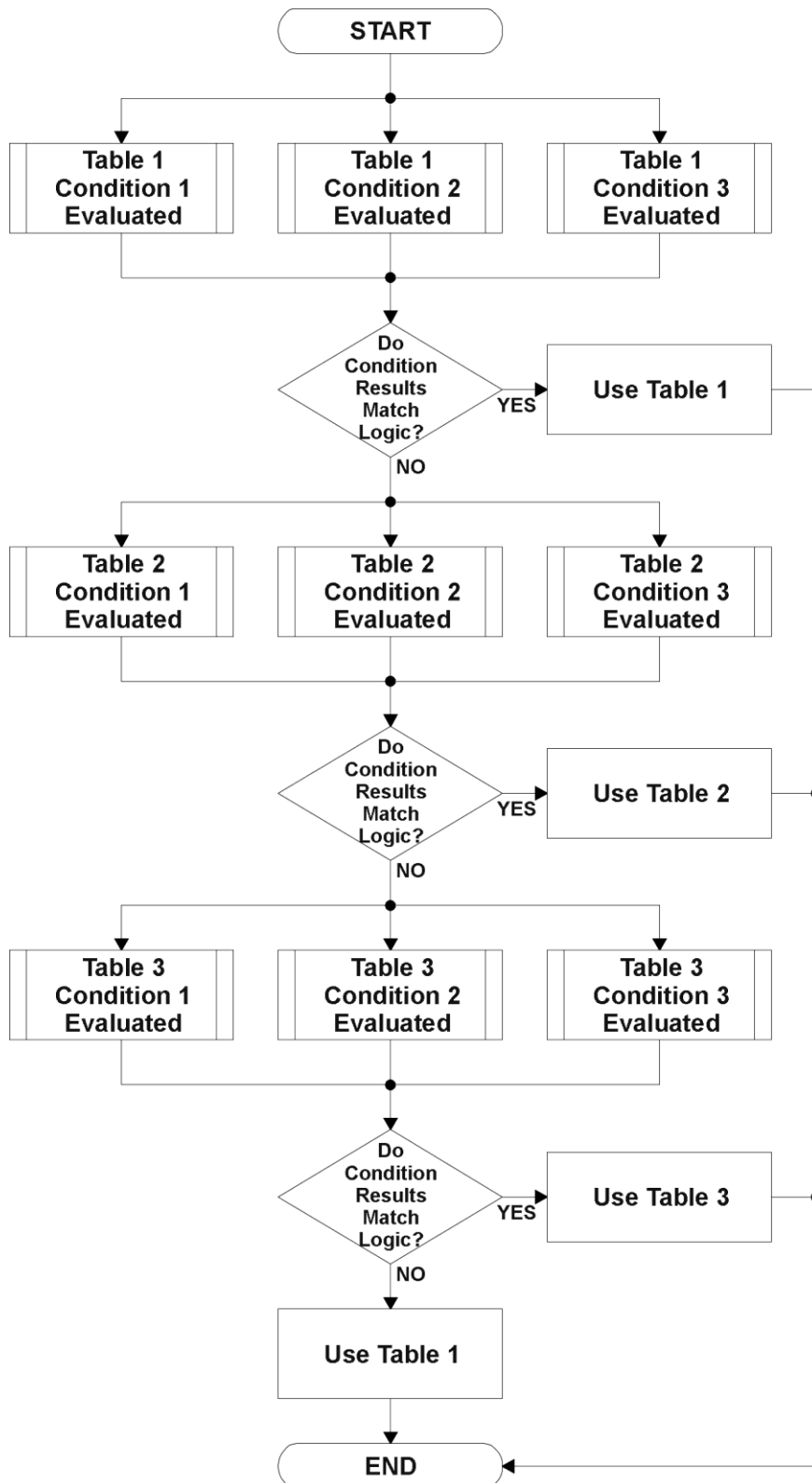

Figure 9 - Programmable Logic Flowchart

### 1.10.1. Conditions Evaluation

The first step in determining which table will be selected as the active table is to first evaluate the conditions associated with a given table. Each table has associated with it up to three conditions that can be evaluated.

Argument 1 is always a logical output from another function block, as listed in Section 1.5. As always, the source is a combination of the functional block type and number, setpoints **Table X, Condition Y, Argument 1 Source** and **Table X, Condition Y, Argument 1 Number**, where both X = 1 to 3 and Y = 1 to 3.

Argument 2 on the other hand, could either be another logical output such as with Argument 1, OR a constant value set by the user. To use a constant as the second argument in the operation, set **Table X, Condition Y, Argument 2 Source** to *Control Constant Data.* Note that the constant value has no unit associated with it in EA, so the user must set it as needed for the application.

The condition is evaluated based on the **Table X, Condition Y Operator** selected by the user. It is always *'=, Equal'* by default. The only way to change this is to have two valid arguments selected for any given condition. Options for the operator are listed in Table 15.

0	=, Equal
1	!=, Not Equal
2	>, Greater Than
3	>=, Greater Than or Equal
4	<, Less Than
5	<=, Less Than or Equal

Table 15 - Condition Operator Options

For example, a condition for a weight going over a certain range could be that the Strain Gauge Input Measured 1 be greater than a certain value to flag a different output. In this case, **"...Argument 1 Source"** would be set to *Strain Gauge Input Measured 1*, **"...Argument 2 Source"** to *Control Constant Data*, and the **"...Operator"** to *'>, Greater Than.'* The **"Constant Value X"** in the Constant Data List would be set to whatever warning weight the application required.

By default, both arguments are set to *Control Source Not Used* which disables the condition, and automatically results in a value of N/A as the result. Although Figure 9 shows only True or False as a result of a condition evaluation, the reality is that there could be four possible results, as described in Table 16.

Value	Meaning	Reason
0	False	(Argument 1) Operator (Argument 2) = False
1	True	(Argument 1) Operator (Argument 2) = True
2	Error	Argument 1 or 2 output was reported as being in an error state
3	Not Applicable	Argument 1 or 2 is not available (i.e. set to <i>Control Source Not Used</i> )

Table 16 - Condition Evaluation Results

### 1.10.2. Table Selection

In order to determine if a particular table will be selected, logical operations are performed on the results of the conditions as determined by the logic in Section 1.10.1. There are several logical combinations that can be selected, as listed in Table 17.

0	Default Table
1	Cnd1 And Cnd2 And Cnd3
2	Cnd1 Or Cnd2 Or Cnd3
3	(Cnd1 And Cnd2) Or Cnd3
4	(Cnd1 Or Cnd2) And Cnd3

Table 17 - Conditions Logical Operator Options

Not every evaluation is going to need all three conditions. The case given in the earlier section, for example, only has one condition listed, i.e. that the Engine RPM be below a certain value. Therefore, it is important to understand how the logical operators would evaluate an Error or N/A result for a condition.

Logical Operator	Select Conditions Criteria
Default Table	Associated table is automatically selected as soon as it is evaluated.
Cnd1 And Cnd2 And Cnd3	<p><b>Should be used when two or three conditions are relevant, and all must be true to select the table.</b></p> <p>If any condition equals False or Error, the table is not selected. An N/A is treated like a True. If all three conditions are True (or N/A), the table is selected.</p> <p>If((Cnd1==True) &amp;&amp;(Cnd2==True)&amp;&amp;(Cnd3==True)) Then Use Table</p>
Cnd1 Or Cnd2 Or Cnd3	<p><b>Should be used when only one condition is relevant. Can also be used with two or three relevant conditions.</b></p> <p>If any condition is evaluated as True, the table is selected. Error or N/A results are treated as False</p> <p>If((Cnd1==True)    (Cnd2==True)    (Cnd3==True)) Then Use Table</p>
(Cnd1 And Cnd2) Or Cnd3	<p><b>To be used only when all three conditions are relevant.</b></p> <p>If both Condition 1 and Condition 2 are True, OR Condition 3 is True, the table is selected. Error or N/A results are treated as False</p> <p>If( ((Cnd1==True)&amp;&amp;(Cnd2==True))    (Cnd3==True) ) Then Use Table</p>
(Cnd1 Or Cnd2) And Cnd3	<p><b>To be used only when all three conditions are relevant.</b></p> <p>If Condition 1 And Condition 3 are True, OR Condition 2 And Condition 3 are True, the table is selected. Error or N/A results are treated as False</p> <p>If( ((Cnd1==True)  ((Cnd2==True)) &amp;&amp; (Cnd3==True) ) Then Use Table</p>

Table 18 - Conditions Evaluation Based on Selected Logical Operator

The default “**Table X, Conditions Logical Operator**” for Table 1 and Table 2 is ‘Cnd1 And Cnd2 And Cnd3,’ while Table 3 is set to be the ‘Default Table.’

### 1.10.3. Logic Block Output

Recall that Table X, where X = 1 to 3 in the Programmable Logic function block does NOT mean Lookup Table 1 to 3. Each table has a setpoint “**Table X – Lookup Table Block Number**” which allows the user to select which Lookup Tables they want associated with a particular Programmable Logic Block. The default tables associated with each logic block are listed in Table 19

Programmable Logic Block Number	Table 1 – Lookup Table Block Number	Table 2 – Lookup Table Block Number	Table 3 – Lookup Table Block Number
1	1	2	3

Table 19 - Programmable Logic Block Default Lookup Table

If the associated Lookup Table does not have an “**X-Axis Source**” selected, then the output of the Programmable Logic block will always be “Not Available” so long as that table is selected. However, should the Lookup Table be configured for a valid response to an input, be it Data or Time, the output of the Lookup Table function block (i.e. the Y-Axis data that has been selected based on the X-Axis value) will become the output of the Programmable Logic function block so long as that table is selected.

Unlike all other function blocks, the Programmable Logic does NOT perform any linearization calculations between the input and the output data. Instead, it mirrors exactly the input (Lookup Table) data. Therefore, when using the Programmable Logic as a control source for another function block, it is HIGHLY recommended that all the associated Lookup Table Y-Axes either be (a) Set between the 0 to 100% output range or (b) all set to the same scale.

### 1.11. Lookup Table Function Block

**Lookup Tables are used to give an output response of up to 10 slopes per input.** The array size of the Response [ ], Point X [ ] and Point Y [ ] setpoints shown in the block diagram above is therefore 6.

Note: If more than 10 slopes are required, a Programmable Logic Block can be used to combine up to three tables to get 30 slopes.

There are two key setpoints that will affect this function block. The first is the “**X-Axis Source**” and “**X-Axis Number**” which together define the Control Source for the function block. When it is changed, the table is automatically updated with new defaults based on the X-Axis source selected if “**Auto update when control changes**” in the Miscellaneous block is *TRUE*.

As stated earlier if “**Auto update when control changes**” is *TRUE*, should the selected Control Source change (i.e. the Min or Max values of the function block are updated), the associated table will also be automatically updated with default settings, based on the new X-Axis limits.

	Initialize the Control Source of a Lookup Table BEFORE changing the table values, as the new settings WILL get erased when the control is updated if the “ <b>Auto update when control changes</b> ” in the Miscellaneous function block is set to <i>TRUE</i> .
---	--

The second setpoint that will affect the function block (i.e. reset to defaults), is the “**X-Axis Type**”. By default, the tables have a ‘*Data Response*’ output. Alternatively, it can be selected as a ‘*Time Response*’.

### 1.11.1. X-Axis, Input Data Response

In the case where the “**X-Axis Type**” = ‘*Data Response*’, the points on the X-Axis represents the data of the control source. These values must be selected within the range of the control source.

When selecting X-Axis data values, there are no constraints on the value that can be entered into any of the X-Axis points. The user should enter values in increasing order to be able to utilize the entire table. Therefore, when adjusting the X-Axis data, it is recommended that X<sub>10</sub> is changed first, then lower indexes in descending order as to maintain the below:

$$\text{MinInputRange} \leq X_0 \leq X_1 \leq X_2 \leq X_3 \leq X_4 \leq X_5 \leq X_6 \leq X_7 \leq X_8 \leq X_9 \leq X_{10} \leq \text{MaxInputRange}$$

As stated earlier, MinInputRange and MaxInputRange will be determined by the X-Axis Source that has been selected.

If some of the data points are ‘*Ignored*’ as described in Section 1.11.4, they will not be used in the X-Axis calculation shown above. For example, if points X<sub>4</sub> and higher are ignored, the formula becomes MinInputRange ≤ X<sub>0</sub> ≤ X<sub>1</sub> ≤ X<sub>2</sub> ≤ X<sub>3</sub> ≤ MaxInputRange instead.

### 1.11.2. Y-Axis, Lookup Table Output

The Y-Axis has no constraints on the data that it represents. This means that inverse, or increasing/decreasing or other responses can be easily established.

In all cases, the controller looks at the entire range of the data in the Y-Axis setpoints, and selects the lowest value as the MinOutRange and the highest value as the MaxOutRange. They are passed directly to other function blocks as the limits on the Lookup Table output. (i.e. used as Xmin and Xmax values in linear calculations.)

However, if some of the data points are ‘*Ignored*’ as described in Section 1.11.4, they will not be used in the Y-Axis range determination. Only the Y-Axis values shown on EA will be considered when establishing the limits of the table when it is used to drive another function block, such as a Math Function Block.

### 1.11.3. Default Configuration, Data Response

By default, all Lookup Tables in the ECU are disabled (“**X-Axis Source**” equals ‘*Control Source Not Used*’). Lookup Tables can be used to create the desired response profiles. If a Strain Gauge input is used as the X-Axis, the output of the Lookup Table will be what the user enters in Y-Axis[] setpoints.

Recall, any controlled function block which uses the Lookup Table as an input source will also apply a linearization to the data. **Therefore, for a 1:1 control response, ensure that the minimum and maximum values of the output correspond to the minimum and maximum values of the table’s Y-Axis.**

All tables (1 to 4) are disabled by default (no control source selected). However, should an “**X-Axis Source**” be selected, the Y-Axis defaults will be in the range of 0 to 100% as described in the “Y-

Axis, Lookup Table Output” section above. X-Axis minimum and maximum defaults will be set as described in the “X-Axis, Data Response” section above.

By default, the X and Y axes data is setup for an equal value between each point from the minimum to maximum in each case.

#### 1.11.4. Point To Point Response

By default, the X and Y axes are setup for a linear response from point (0,0) to (10,10), where the output will use linearization between each point, as shown in Figure 10. To get the linearization, each **“Point N – Response”**, where N = 1 to 10, is setup for a *‘Ramp To’* output response.

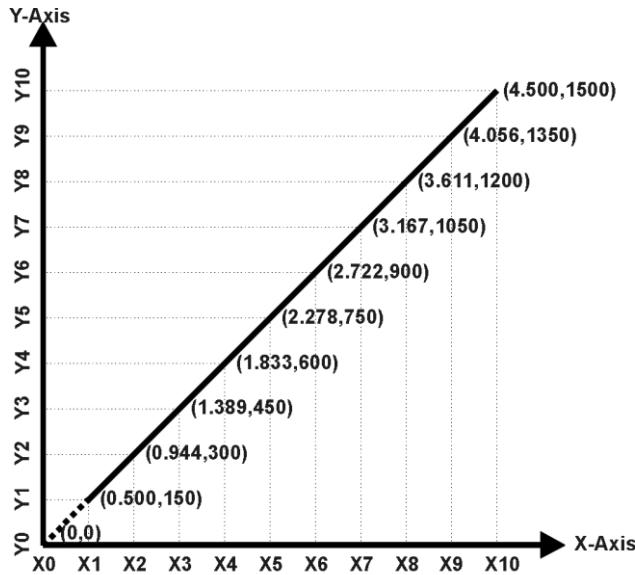

Figure 10 - Lookup Table with "Ramp To" Data Response

Alternatively, the user could select a *‘Jump To’* response for **“Point N – Response”**, where N = 1 to 10. In this case, any input value between  $X_{N-1}$  to  $X_N$  will result in an output from the Lookup Table function block of  $Y_N$ .

An example of a Math function block (0 to 100) used to control a default table (0 to 100) but with a *‘Jump To’* response instead of the default *‘Ramp To’* is shown in Figure 11.

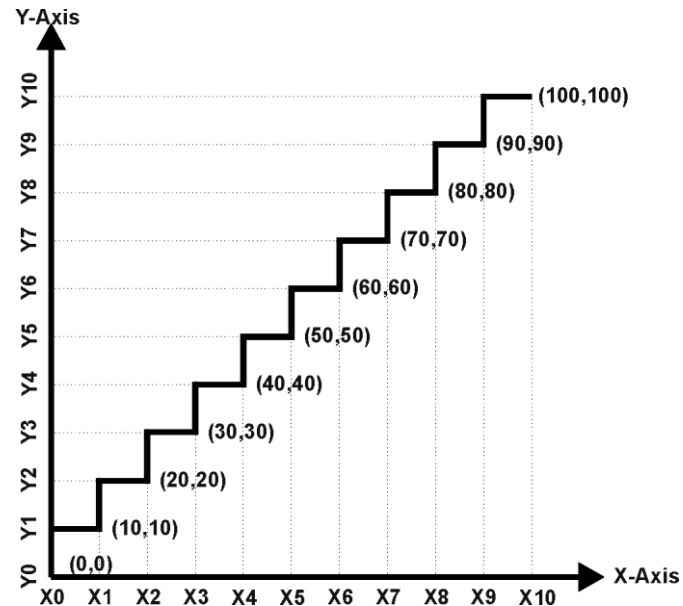

Figure 11 - Lookup Table with "Jump To" Data Response

Lastly, any point except (0,0) can be selected for an 'ignore' response. If "Point N – Response" is set to ignore, then all points from (X<sub>N</sub>, Y<sub>N</sub>) to (X<sub>5</sub>, Y<sub>5</sub>) will also be ignored. For all data greater than X<sub>N-1</sub>, the output from the Lookup Table function block will be Y<sub>N-1</sub>.

A combination of 'Ramp To', 'Jump To' and 'Ignore' responses can be used to create an application specific output profile.

### 1.11.5. X-Axis, Time Response

As mentioned in Section 1.8, a Lookup Table can also be used to get a custom output response where the "X-Axis Type" is a 'Time Response.' When this is selected, the X-Axis now represents time, in units of milliseconds, while the Y-Axis still represents the output of the function block.

In this case, the "X-Axis Source" is treated as a digital input. If the signal is actually an analog input, it is interpreted like a digital input per Figure 8. When the control input is ON, the output will be changed over a period of time based on the profile in the Lookup Table. Once the profile has finished (i.e. index 10, or 'Ignored' response), the output will remain at the last output at the end of the profile until the control input turns OFF.

When the control input is OFF, the output is always at zero. When the input comes ON, the profile ALWAYS starts at position (X<sub>0</sub>, Y<sub>0</sub>) which is 0 output for 0ms.

In a time response, the interval time between each point on the X-axis can be set anywhere from 1ms to 24 hours. [86,400,000 ms]

## 1.12. Simple Conditional Logic Function Blocks

The Simple Conditional Logic Blocks provide a way of connecting different blocks and comparing them to one another. The output of the Conditional Logic Blocks is either 0 (FALSE) or 1 (TRUE).

There are three operations that take place in the Conditional Logic Blocks which allows the user to make more elaborate comparisons. The first two operations, “**Condition 1 Operator (Argument 1/2)**” and “**Condition 2 Operator (Argument 1/2)**” compare two separate values from different selectable control sources. The operations for these two operators are listed in Table 20.

Value	Operation	Meaning
0	Not Used	Result = False
1	=	True when InA Equals InB
2	!=	True when InA Not Equal InB
3	>	True when InA Greater Than InB
4	>=	True when InA Greater Than or Equal InB
5	<	True when InA Less Than InB
6	<=	True when InA Less Than or Equal InB
7	OR	True when InA or InB is True
8	AND	True when InA and InB are True
9	XOR	True when InA/InB is True, but not both

Table 20 - Available Operation for Conditions 1 and 2 Operators

The last operation is used between the results of both Condition 1 Operator and Condition 2 Operator using logic gates operations. The list of available operations for “**Conditional Result Operator**” are listed in Table 21.

Value	Operation	Meaning
0	OR	True when Op1 or Op2 is True
1	AND	True when Op1 and Op2 are True
2	XOR	True when Op1/Op2 is True, but not both

Table 21 - Available Operations for Conditional Result Operator



When configuring a Conditional Block and only one comparison is needed, it is necessary that operation selected for “**Conditional Result Operator**” is set to 1 (‘OR, True When Op1 or Op2 is True’)

### 1.13. Set / Reset Latch Function Blocks

The Set-Reset Block consists of only 2 control sources: “**Reset Source**” and “**Set Source**”. The purpose of these blocks is to simulate a modified latching function in which the ‘Reset Signal’ has more precedence. The ‘latching’ function works as per the Table 22 below.

‘Set Signal’	‘Reset Signal’	‘Set-Reset Block Output’ (Initial State: OFF)
OFF	OFF	Latched State
OFF	ON	OFF
ON	OFF	ON
ON	ON	OFF

Table 22 – Set-Reset Function block operation

The **Reset** and **Set** sources have associated with them a minimum and maximum threshold values which determine the ON and OFF state. For the **Reset Source** are “**Reset Minimum Threshold**” and “**Reset Maximum Threshold**”. Similarly, for the **Set Source** are “**Set Minimum Threshold**”

and **“Set Maximum Threshold”**. These setpoints also allow to have a dead band in between ON/OFF states and they are in terms of percentage of input selected.

As seen in Table 22 above, the ‘Reset Signal’ has more precedence over the ‘Set Signal’ - if the state of ‘Reset Signal’ is ON, the state of ‘Set-Reset Block Output’ will be OFF. To create an ON state in ‘Set-Reset Block Output’ the state of ‘Reset Signal’ must be OFF while the state of ‘Set Signal’ is ON. In this case, the state of ‘Set-Reset Block Output’ will remain ON even if ‘Set Signal’ turns OFF as long as ‘Reset Signal’ remains OFF. As soon as the ‘Reset Signal’ turns ON the ‘Set-Reset Block Output’ will turn OFF regardless of the state of ‘Set Signal’.

### 1.14. CAN Transmit Function Block

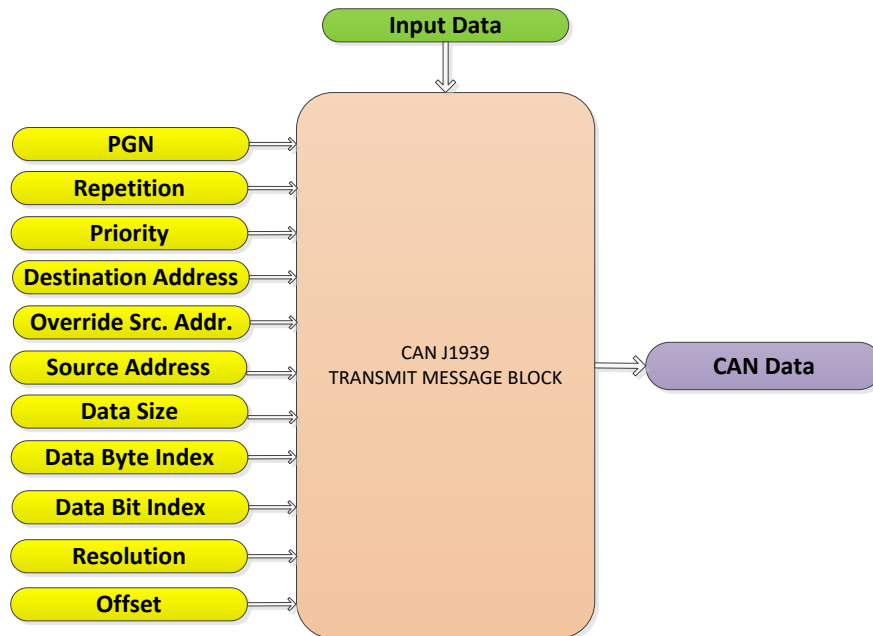

Figure 12 - CAN Transmit Function Block

The CAN Transmit function block is used to send any output from another function block (i.e. input, status or feedback signals) to the J1939 network.

Normally, to disable a transmit message, the **“Transmit Repetition Rate”** is set to zero. However, should message share its Parameter Group Number (PGN) with another message, this is not necessarily true. In the case where multiple messages share the same **“Transmit PGN”**, the repetition rate selected in the message with the **LOWEST** number will be used for ALL the messages that use that PGN.

By default, all messages are sent on Proprietary B PGNs as broadcast messages. If all of the data is not necessary, disable the entire message by setting the lowest channel using that PGN to zero. If some of the data is not necessary, simply change the PGN of the superfluous channel(s) to an unused value in the Proprietary B range.



At power up, transmitted message will not be broadcasted until after a 5 second delay. This is done to prevent any power up or initialization conditions from creating problems on the network.

Since the defaults are PropB messages, the “**Transmit Message Priority**” is always initialized to 6 (low priority) and the “**Destination Address (for PDU1)**” setpoint is not used. This setpoint is only valid when a PDU1 PGN has been select, and it can be set either to the Global Address (0xFF) for broadcasts, or sent to a specific address as setup by the user.

The 4CH-SG allows to transmit CAN messages with a masked source address. The associated setpoints for this configuration are “**Override Source Address**” and “**Source Address**”. When “**Override Source Address**” setpoint is set to *FALSE* the CAN Transmit will transmit with the address the 4CH-SG has claimed. However, when this is set to *TRUE*, the user can configure a source address to be used for that CAN Transmit, from 0...255. Each CAN Transmit setpoint group has the ability to have its own source address configured.

The “Transmit Data Size”, “Transmit Data Index in Array (LSB)”, “Transmit Bit Index in Byte (LSB)”, “Transmit Resolution” and “Transmit Offset” can all be use to map the data to any SPN supported by the J1939 standard. The defaults used by the 4CH-SG are all for proprietary SPNs, and are defined in detail in Section 3.3.

Note: CAN Data = (Input Data – Offset)/Resolution

The 4CH-SG supports up to 5 unique CAN Transmit Messages, all of which can be programmed to send any available data to the CAN network. By default, the first CAN Transmit block is pre-configured to send all Strain Gauge Input measurements. The details are outlined in Section 3.3, and the default list is shown in Table 23 below.

<b>Block#, Signal #</b>	<b>Default Transmit Data</b>	<b>(PGN)</b>
1, 1	Strain Gauge Input 1	(0xFF00)
1, 2	Strain Gauge Input 2	(0xFF00)
1, 3	Strain Gauge Input 3	(0xFF00)
1, 4	Strain Gauge Input 4	(0xFF00)
2, 1	Control Source Not Used	(0xFF01)
2, 2	Control Source Not Used	(0xFF01)
2, 3	Control Source Not Used	(0xFF01)
2, 4	Control Source Not Used	(0xFF01)
3, 1	Control Source Not Used	(0xFF01)
3, 2	Control Source Not Used	(0xFF01)
3, 3	Control Source Not Used	(0xFF01)
3, 4	Control Source Not Used	(0xFF01)
4, 1	Control Source Not Used	(0xFF01)
4, 2	Control Source Not Used	(0xFF01)
4, 3	Control Source Not Used	(0xFF01)
4, 4	Control Source Not Used	(0xFF01)
5, 1	Control Source Not Used	(0xFF01)
5, 2	Control Source Not Used	(0xFF01)
5, 3	Control Source Not Used	(0xFF01)
5, 4	Control Source Not Used	(0xFF01)

Table 23 - Default CAN Transmit Messages

## 1.15. CAN Tare Function Block

The CAN Tare function block is a means to zero/tare the input via CAN messages. If desired to tare the inputs via this function block, the user must send the specific CAN message frames the 4CH-SG expects. By default, the “**Receive PGN**” is set to 0xFFA5 but can be configured to a different PGN.

The message to be sent is a 2-byte message with the first byte being the command while the second byte determines the operation. See the below tables for the list of commands and operations.

Command	First Byte Data
Enter Calibration	0xAB
Exit Calibration and Save	0xBA

Table 24 - CAN Tare Command Byte

Options	Bits on Second Byte Data
Tare Strain Gauge Input 1	1 <sup>st</sup> bit location
Tare Strain Gauge Input 2	2 <sup>nd</sup> bit location
Tare Strain Gauge Input 3	3 <sup>rd</sup> bit location
Tare Strain Gauge Input 4	4 <sup>th</sup> bit location
Minimum Sum of all Strain Gauge Inputs is saved as a Constant in Constant Data List	5 <sup>th</sup> bit location
Maximum Sum of all Strain Gauge Inputs is saved as a Constant in Constant Data List	6 <sup>th</sup> bit location

Table 25 - CAN Tare Option Byte

For example, if Strain Gauge Inputs 1 & 3 need to be Tared, the following command would be sent to the 4CH-SG unit (with the default settings)

PGN	Length	D0	D1
0xFFA5	2	0xAB	0x05 (00000101b)

Then to save the calibration settings to the flash, the following command needs to be sent:

PGN	Length	D0	D1
0xFFA5	2	0xBA	0xnn

D1: 0xnn (this byte is ignored when 0xBA is sent)

## 1.16. CAN Receive Function Block

The CAN Receive function block is designed to take any SPN from the J1939 network, and use it as an input to another function block.

The **Receive Message Enabled** is the most important setpoint associated with this function block and it should be selected first. Changing it will result in other setpoints being enabled/disabled as appropriate. By default ALL receive messages are disabled.

Once a message has been enabled, a Lost Communication fault will be flagged if that message is not received within the **Receive Message Timeout** period. This could trigger a Lost Communication event as described in section **Error! Reference source not found.6**. In order to avoid timeouts on a heavily saturated network, it is recommended to set the period at least three times longer than the expected update rate. To disable the timeout feature, simply set this value to

zero, in which case the received message will never timeout and will never trigger a Lost Communication fault.

By default, all control messages are expected to be sent to the 4CH-SG Controller on Proprietary B PGNs. However, should a PDU1 message be selected, the 4CH-SG Controller can be setup to receive it from any ECU by setting the **Specific Address that sends the PGN** to the Global Address (0xFF). If a specific address is selected instead, then any other ECU data on the PGN will be ignored.

The **Receive Data Size**, **Receive Data Index in Array (LSB)**, **Receive Bit Index in Byte (LSB)**, **Receive Resolution** and **Receive Offset** can all be used to map any SPN supported by the J1939 standard to the output data of the Received function block.

As mentioned earlier, a CAN receive function block can be selected as the source of the control input for the output function blocks. When this is the case, the **Received Data Min** (Off Threshold) and **Received Data Max** (On Threshold) setpoints determine the minimum and maximum values of the control signal. As the names imply, they are also used as the On/Off thresholds for digital output types. These values are in whatever units the data is AFTER the resolution and offset is applied to CAN receive signal. The 4CH-SG Controller supports up to five unique CAN Receive Messages.

## 2. Installation Instructions

### 2.1. Dimensions and Pinout

The 4-Channel Strain Gauge Input Controller is packaged in a plastic housing from Deutsch IPD. The assembly carries an IP67 rating.

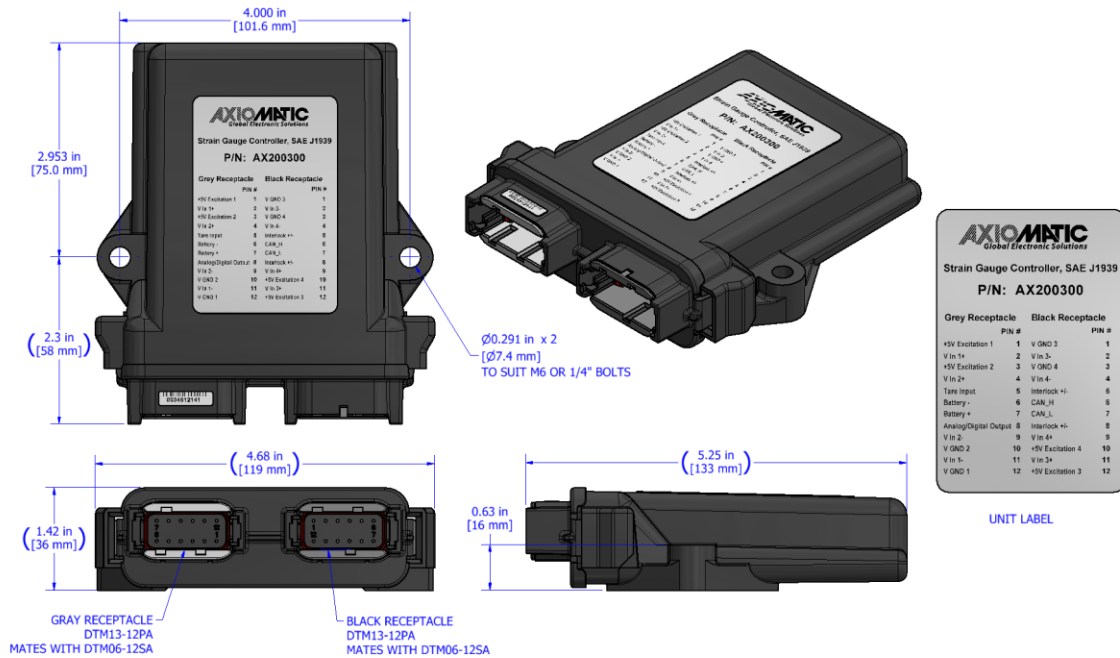

Figure 13 - Housing Dimensions

Grey Connector		Black Connector	
Pin #	Function	Pin #	Function
1	+5V Excitation 1	1	+5V Excitation 1
2	V IN 1+	2	V IN 1+
3	+5V Excitation 2	3	+5V Excitation 2
4	V IN 2+	4	V IN 2+
5	Tare Input	5	Tare Input
6	BATT-	6	BATT-
7	BATT+	7	BATT+
8	Digital Output	8	Digital Output
9	V IN 2 -	9	V IN 2 -
10	GND 2	10	GND 2
11	V IN 1 -	11	V IN 1 -
12	GND 1	12	GND 1

Table 26 - Connector Pinout

### 2.2. Mounting Instructions

#### 2.2.1. Notes & Warnings

- Do not install near high-voltage or high-current devices.
- Note the operating temperature range. All field wiring must be suitable for that temperature range.

- Install the unit with appropriate space available for servicing and for adequate wire harness access (15 cm) and strain relief (30 cm).
- Do not connect or disconnect the unit while the circuit is live, unless the area is known to be non-hazardous.

### 2.2.2. Mounting

Mounting holes sized for ¼ inch or M6 bolts. The bolt length will be determined by the end-user’s mounting plate thickness. The mounting flange of the controller is 0.63 inches (16 mm) thick.

All field wiring should be suitable for the operating temperature range.

Install the unit with appropriate space available for servicing and for adequate wire harness access (6 inches or 15 cm) and strain relief (12 inches or 30 cm).

### 2.2.3. Connections

Use the following Deutsch IPD mating plugs to connect to the integral receptacles. Wiring to these mating plugs must be in accordance with all applicable local codes. Suitable field wiring for the rated voltage and current must be used. The rating of the connecting cables must be at least 85°C. For ambient temperatures below –10°C and above +70°C, use field wiring suitable for both minimum and maximum ambient temperature.

Refer to the respective Deutsch IPD datasheets for usable insulation diameter ranges and other instructions.

Receptacle Contacts	Mating Sockets as appropriate (Refer to <a href="http://www.laddinc.com">www.laddinc.com</a> for more information on the contacts available for this mating plug.)
Mating Connector	DTM06-12SA, DTM06-12SB, 2 wedges WM12S, 24 contacts (0462-201-20141)

### 3. OVERVIEW OF J1939 FEATURES

---

The software was designed to provide flexibility to the user with respect to messages sent to and from the ECU by providing:

- Configurable ECU Instance in the NAME (to allow multiple ECUs on the same network)
- Configurable Transmit PGN and SPN Parameters
- Configurable Receive PGN and SPN Parameters
- Sending DM1 Diagnostic Message Parameters
- Reading and reacting to DM1 messages sent by other ECUs
- Diagnostic Log, maintained in non-volatile memory, for sending DM2 messages

#### 3.1. Introduction To Supported Messages

The ECU is compliant with the standard SAE J1939, and supports the following PGNs

##### From J1939-21 - Data Link Layer

- |   |                  |
|---|------------------|
| • Request   | 59904 (\$00EA00) |
| • Acknowledgment  | 59392 (\$00E800) |
| • Transport Protocol – Connection Management                    | 60416 (\$00EC00) |
| • Transport Protocol – Data Transfer Message                    | 60160 (\$00EB00) |
| • PropB Transmit, Default Measured Inputs Feedback Message      | 65280 (\$00FF00) |
| • PropB Transmit, Default Proportional Outputs Target Message   | 65296 (\$00FF10) |
| • PropB Transmit, Default Proportional Outputs Feedback Message | 65312 (\$00FF20) |
| • PropB Transmit, Default Digital I/O State Feedback Message    | 65328 (\$00FF30) |
| • PropB Receive, Default Output Control Data Message            | 65408 (\$00FF80) |
| • PropB Receive, Default Output Enable Data Message             | 65424 (\$00FF90) |
| • PropB Receive, Default Output Override Data Message           | 65440 (\$00FFA0) |
| • PropB Receive, Default PID Feedback Data Message              | 65456 (\$00FFB0) |

Note: Any Proprietary B PGN in the range 65280 to 65535 (\$00FF00 to \$00FFFF) can be selected

Note: The Proprietary A PGN 61184 (\$00EF00) can also be selected for any of the messages

##### From J1939-73 - Diagnostics

- |  |                  |
|--|------------------|
| • DM1 – Active Diagnostic Trouble Codes                        | 65226 (\$00FECA) |
| • DM2 – Previously Active Diagnostic Trouble Codes             | 65227 (\$00FECB) |
| • DM3 – Diagnostic Data Clear/Reset for Previously Active DTCs | 65228 (\$00FECC) |
| • DM11 - Diagnostic Data Clear/Reset for Active DTCs           | 65235 (\$00FED3) |
| • DM14 – Memory Access Request                                 | 55552 (\$00D900) |
| • DM15 – Memory Access Response                                | 55296 (\$00D800) |
| • DM16 – Binary Data Transfer                                  | 55040 (\$00D700) |

##### From J1939-81 - Network Management

- |                                |                  |
|--------------------------------|------------------|
| • Address Claimed/Cannot Claim | 60928 (\$00EE00) |
| • Commanded Address            | 65240 (\$00FED8) |

##### From J1939-71 – Vehicle Application Layer

- |                           |                  |
|---------------------------|------------------|
| • Software Identification | 65242 (\$00FEDA) |
|---------------------------|------------------|

None of the application layer PGNs are supported as part of the default configurations, but they can be selected as desired for either transmit or received function blocks.

Setpoints are accessed using standard Memory Access Protocol (MAP) with proprietary addresses. The Electronic Assistant<sup>®</sup> EA (EA) allows for quick and easy configuration of the unit over the CAN network.

### 3.2. NAME, Address and Software ID

#### J1939 NAME

The 4CH-SG ECU has the following defaults for the J1939 NAME. The user should refer to the SAE J1939/81 standard for more information on these parameters and their ranges.

Arbitrary Address Capable	Yes
Industry Group	0, Global
Vehicle System Instance	0
Vehicle System	0, Non-specific system
Function	126, Axiomatic I/O Controller
Function Instance	26, Axiomatic AX200300, 4 Channel Strain Gauge Open Wire Protection
<b>ECU Instance</b>	<b>0, First Instance</b>
Manufacture Code	162, Axiomatic Technologies Corporation
Identity Number	Variable, uniquely assigned during factory programming for each ECU

The ECU Instance is a configurable setpoint associated with the NAME. Changing this value will allow multiple ECUs of this type to be distinguishable by other ECUs (including the Electronic Assistant<sup>®</sup> EA) when they are all connected on the same network.

#### ECU Address

The default value of this setpoint is 128 (0x80), which is the preferred starting address for self-configurable ECUs as set by the SAE in J1939 tables B3 to B7. The EA will allow the selection of any address between 0 to 253, and **it is the user's responsibility to select an address that complies with the standard**. The user must also be aware that since the unit is arbitrary address capable, if another ECU with a higher priority NAME contends for the selected address, the 4CH-SG will continue select the next highest address until it find one that it can claim. See J1939/81 for more details about address claiming.

#### Software Identifier

PGN 65242	Software Identification	- SOFT	
Transmission Repetition Rate:	On request		
Data Length:	Variable		
Extended Data Page:	0		
Data Page:	0		
PDU Format:	254		
PDU Specific:	218 PGN Supporting Information:		
Default Priority:	6		
Parameter Group Number:	65242 (0xFEDA)		
Start Position	Length	Parameter Name	SPN
1	1 Byte	Number of software identification fields	965
2-n	Variable	Software identification(s), Delimiter (ASCII “*”)	234

For the 4CH-SG ECU, Byte 1 is set to 5, and the identification fields are as follows

**(Part Number)\*(Version)\*(Date)\*(Owner)\*(Description)**

EA shows all this information in “General ECU Information”, as shown below

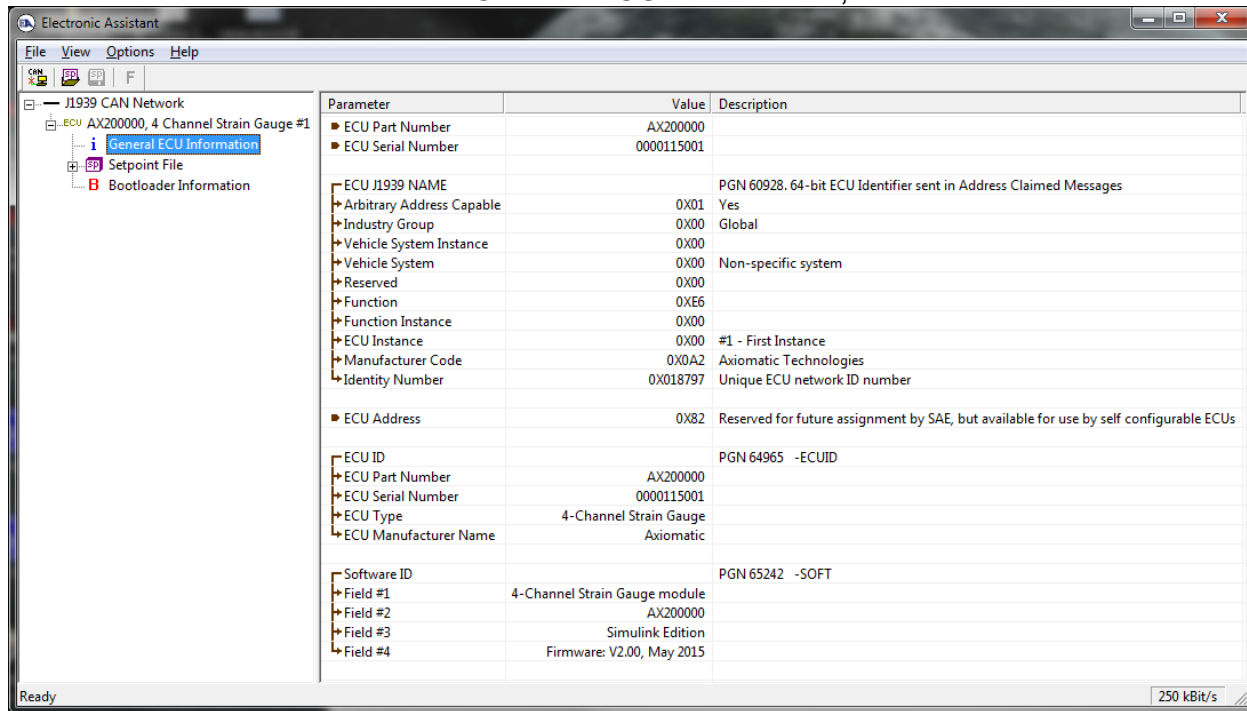

Note: The information provided in the Software ID is available for any J1939 service tool which supports the PGN -SOFT.

### 3.3. CAN Transmit Message Defaults

This section outlines the **default** settings of the 4CH-SG CAN transmissions. Recall, however, that this is a fully programmable unit, such that all these SPNs can be sent on different PGNs if so desired.

In all the messages shown below, not all the transmitted values have an SPN assigned to them, as this ECU only uses the SPNs for diagnostic trouble codes. If the SPN is shown as N/A, this means that the associated value cannot be used to generate DTCs.

The “Strain Gauge Inputs Message” has the following default configuration.

Start Position	Length	Parameter Name	SPN
PGN 65280      Strain Gauge Input Measured			
Transmission Repetition:      1000ms (1 second transmit rate)			
Data Length:                      8			
Data Page:                         0			
PDU Format:                        254			
PDU Specific:                    GE      PGN Supporting Information:			
Default Priority:                 6			
Parameter Group Number:      65280 (0xFF00)			
1-2	2 byte	Strain Gauge Weight Data 1	520448
3-4	2 byte	Strain Gauge Weight Data 2	520449
5-6	2 byte	Strain Gauge Weight Data 3	520450
7-8	2 byte	Strain Gauge Weight Data 4	520451

## Strain Gauge Input Measured X, where X = 1 to 4

This value reflects the measured strain gauge load cell. By default, this value will be in terms of g/bit (grams per bit).

Data Length:	2 byte
Resolution:	1kg/bit, 0 offset
Data Range:	0 to 64255 g
Type:	Measured
Suspect Parameter Number:	520448 to 520451 (0x7F100 to 0x7F103, proprietary SPNs)
Parameter Group Number:	65280

## 4. ECU SETPOINTS ACCESSED WITH ELECTRONIC ASSISTANT

Many setpoints have been reference throughout this manual. This section describes in detail each setpoint, and their defaults and ranges. For more information on how each setpoint is used by the 4CH-SG, refer to the relevant section of the User Manual.

### 4.1. J1939 Network Setpoints

The J1939 Network setpoints primarily deal with the CAN Network. Refer to the notes for more information about each setpoint.

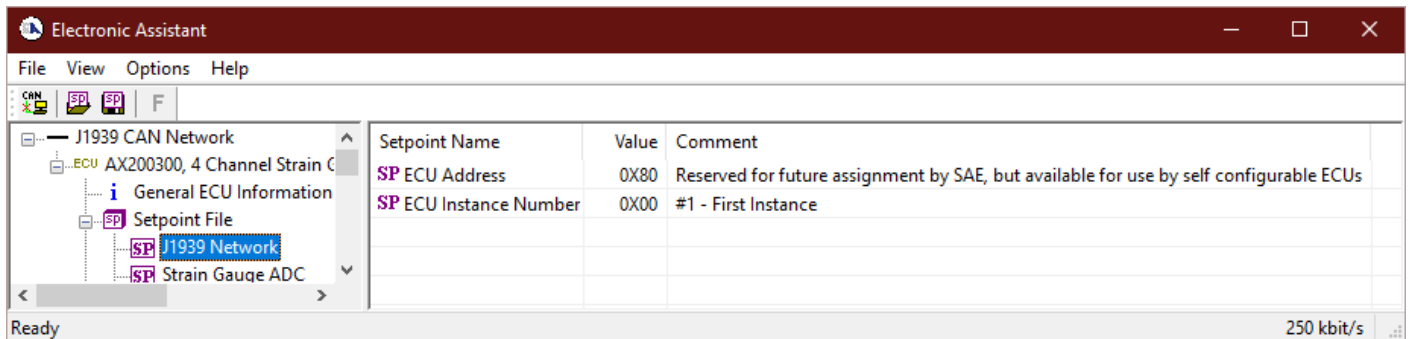

Screen Capture of Default J1939 Network Setpoints

Name	Range	Default	Notes
ECU Instance Number	Drop List	0, #1 – First Instance	Per J1939-81
ECU Address	0 to 253	128 (0x80)	Preferred address for a self-configurable ECU

If non-default values for the “**ECU Instance Number**” or “**ECU Address**” are used, they will not be updated during a setpoint file flash. These parameters need to be changed manually in order to prevent other units on the network to be affected. When they are changed, the controller will claim its new address on the network. It is recommended to close and re-open the CAN connection on EA after the file is loaded so that only the new NAME and address are showing in the J1939 CAN Network ECU list.

### 4.2. Strain Gauge ADC Setpoints

The Strain Gauge ADC function block is defined in Section 1.2. Please refer there for detailed information about how all these setpoints are used.

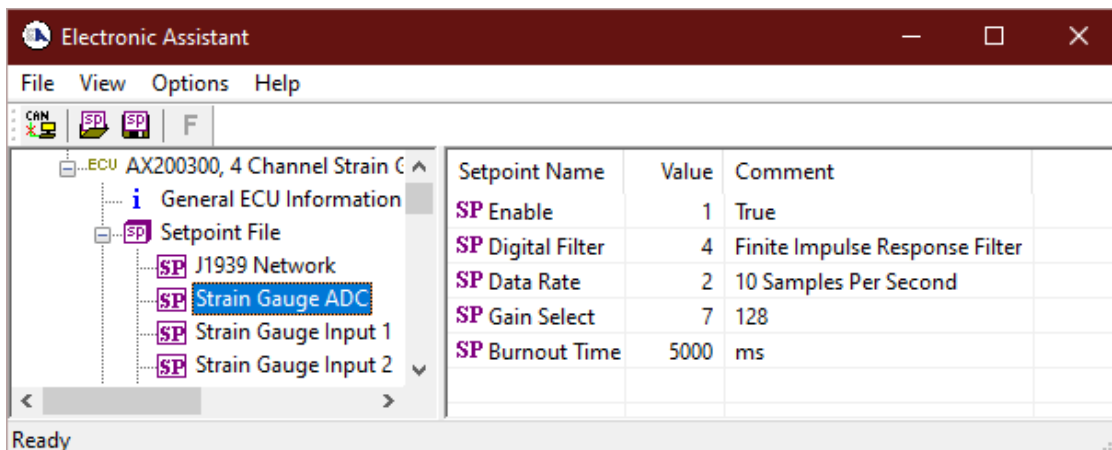

Screen Capture of Default Strain Gauge ADC Setpoints

Name	Range	Default	Notes
Enable	Drop List	1 - TRUE	Refer to Section 1.2
Digital Filter	Drop List	4 - FIR	Refer to Section 1.2
Data Rate	Drop List	2 - 10 SPS	Refer to Section 1.2
Gain Select	Drop List	128	Refer to Section 1.2
Burnout Time	0 to 5000 ms	5000 ms	Refer to Section 1.2

### 4.3. Strain Gauge Input Setpoints

The Strain Gauge Input function block is defined in Section 1.3. Please refer there for detailed information about how all these setpoints are used.

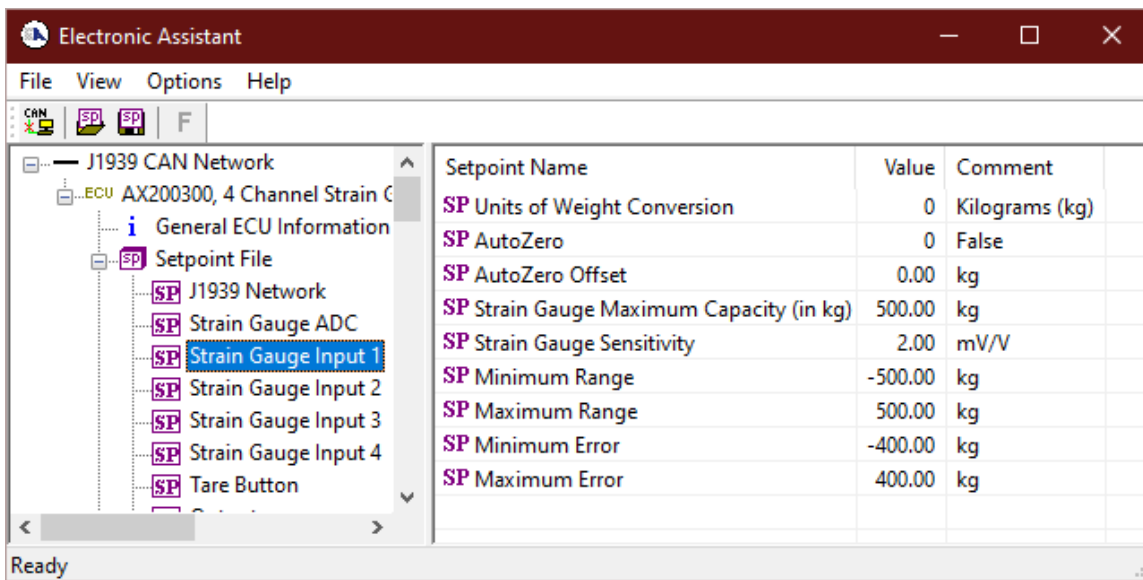

Screen Capture of Default Strain Gauge Input 1 Setpoints

Name	Range	Default	Notes
Units of Weight Conversion	Drop List	0 - Kilograms (kgs)	Units of conversion that will be used internally to measure weight
AutoZero	Drop List	0 - False	When set to TRUE, the AutoZero command will auto null the current weight measured by the controller
AutoZero Offset	-60000 to 60000	0 (kg/lbs)	Updated when AutoZero command is used. However, it can be updated at anytime.
Strain Gauge Maximum Capacity	0 to 50000	500 kg	
Strain Gauge Sensitivity	0 to 50	2.00 mV/V	
Minimum Range	-Maximum Capacity to Maximum Range	-500 kg	This setpoint is automatically updated when Strain Gauge Maximum Capacity is changed. This range along with Maximum Range should be adjusted if intended to use a Strain Gauge Input as a Control Source to an Output Function Block
Maximum Range	Minimum Range to Maximum Capacity	500 kg	This setpoint is automatically updated when Strain Gauge Maximum Capacity is changed. This range along with Minimum Range should be adjusted if intended to use a Strain Gauge Input as a Control Source to an Output Function

			Block
Minimum Error	-Maximum Capacity to Maximum Error	-400 kg	This setpoint is automatically updated when Strain Gauge Maximum Capacity is changed. This range will affect when associated diagnostic errors are triggered.
Maximum Error	Minimum Error to Maximum Capacity	400 kg	This setpoint is automatically updated when Strain Gauge Maximum Capacity is changed. This range will affect when associated diagnostic errors are triggered.

#### 4.4. Tare Button Setpoints

The Tare/Calibration Input function block is defined in Section 1.4. Please refer to that section for detailed information on how these setpoints are used.

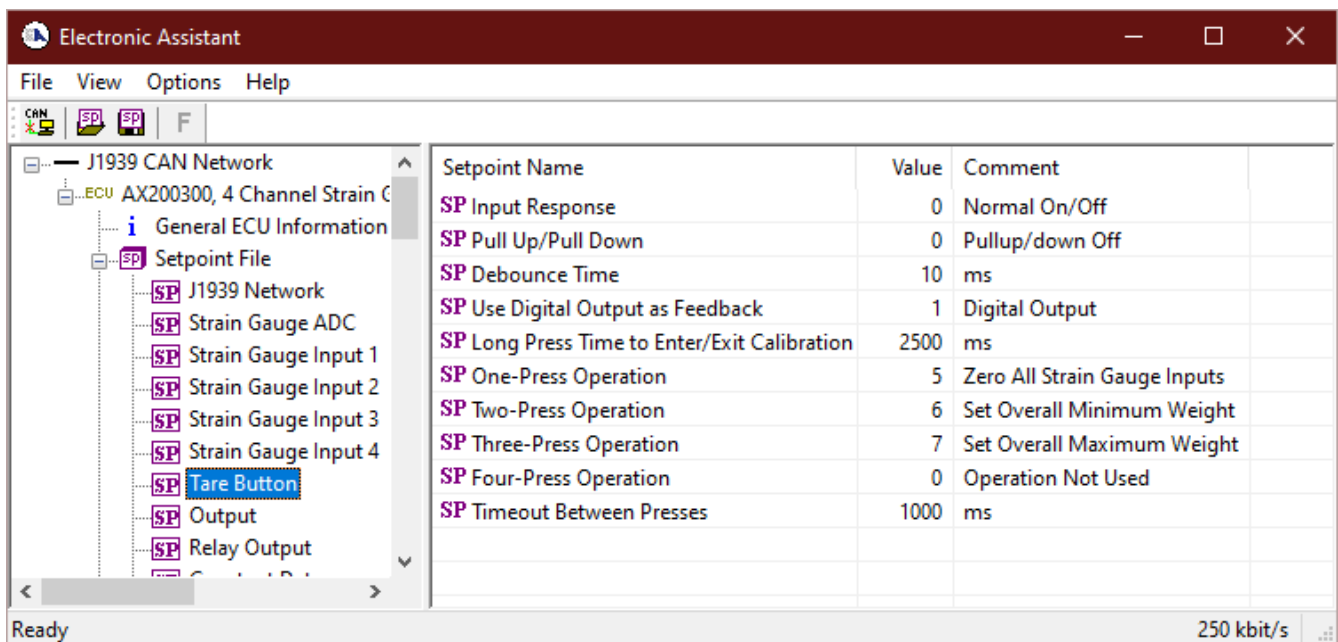

Screen Capture of Default Tare Button Setpoints

Name	Range	Default	Notes
Input Response	Drop List	0 - Normal On/Off	Refer to Table 2
Pullup/Pulldown Resistor	Drop List	0 - Pullup/down Off	Refer to Table 3
Debounce Time	0 to 60000	10ms	Refer to Figure 5
Use Digital Outputs as Feedback	Drop List	1 - Digital Output	Refer to Table 4
Long Press Time to Enter/Exit Calibration	0 to 0xFFFFFFFF	2500ms	Time required to have the Tare button engaged to Enter and Exit Calibration. Refer to Figure 6
One-Press Operation	Drop List	5 - Zero All Strain Gauge Input	Refer to Table 5
Two-Press Operation	Drop List	6 - Set Overall Minimum Weight	Sets the overall minimum weight of all 4 strain gauge inputs for the application. Refer to Table 5
Three-Press Operation	Drop List	7 - Set Overall Maximum Weight	Sets the overall maximum weight of all 4 strain gauge inputs for the application. Refer to Table 5
Four-Press Operation	Drop List	0 - Operation Not Used	Refer to Table 5

Timeout Between Presses	0 to 0xFFFFFFFF	1000ms	Refer to Figure 7
-------------------------	-----------------	--------	-------------------

### 4.5. Digital/Analog Output Setpoints

The Digital/Analog Output function block is defined in Section 1.6. Please refer to that section for a more detailed description on how these setpoints are used.

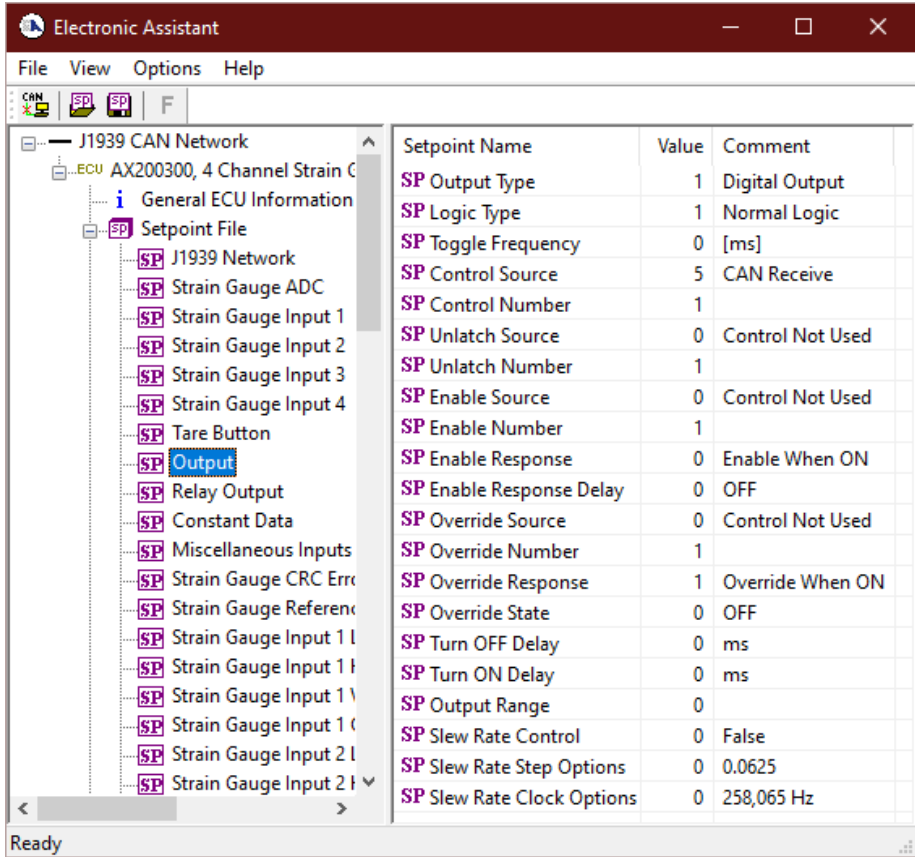

Screen Capture of Default Digital/Analog Output Setpoints

Name	Range	Default	Notes
Output Type	Drop List	1 - Digital Output	If value is set to 0, Output is disabled
Logic Type	Drop List	1 - Normal Logic	Refer to Table 12
Toggle Frequency	Depends on Source	1	Refer to Section 1.6.3
Control Source	Drop List	5 - CAN Receive	Refer to Table 6
Control Number	Depends on Source	1	Refer to Table 6
Unlatch Source	Drop List	0 - Control Source Not Used	Refer to Table 6
Unlatch Number	Depends on Source	1	Refer to Table 6
Enable Source	Drop List	0 - Control Source Not Used	Refer to Table 6
Enable Number	Depends on Source	1	Refer to Table 6
Enable Response	Drop List	0 - Enable When On	Refer to Table 11
Enable Response Delay	Drop List	0 - OFF	Refer to Section 1.6.2
Override Source	Drop List	0 - Control Source Not Used	Refer to Table 6
Override Number	Depends on Source	1	Refer to Table 6

Override Response	Drop List	0 - Override When On	Refer to Table 9
Override State	Drop List	0 - OFF	Refer to Table 10
Turn OFF Delay	0 to 86400000	0 ms	Refer to Section 1.6.2
Turn ON Delay	0 to 86400000	0 ms	Refer to Section 1.6.2
Output Range	Drop List	0 - (0 to 5V) OR (4 to 20mA)	Refer to Section 1.6
Slew Rate Control	Drop List	0 - False	Refer to Section 1.6
Slew Rate Step Options	Drop List	0 - 0.0625	Refer to Section 1.6
Slew Rate Clock Options	Drop List	0 - 258065 Hz	Refer to Section 1.6

#### 4.6. Interlock/Relay Output Setpoints

The Interlock/Relay Output function block is defined in Section 1.6. Please refer to that section for a more detailed description on how these setpoints are used.

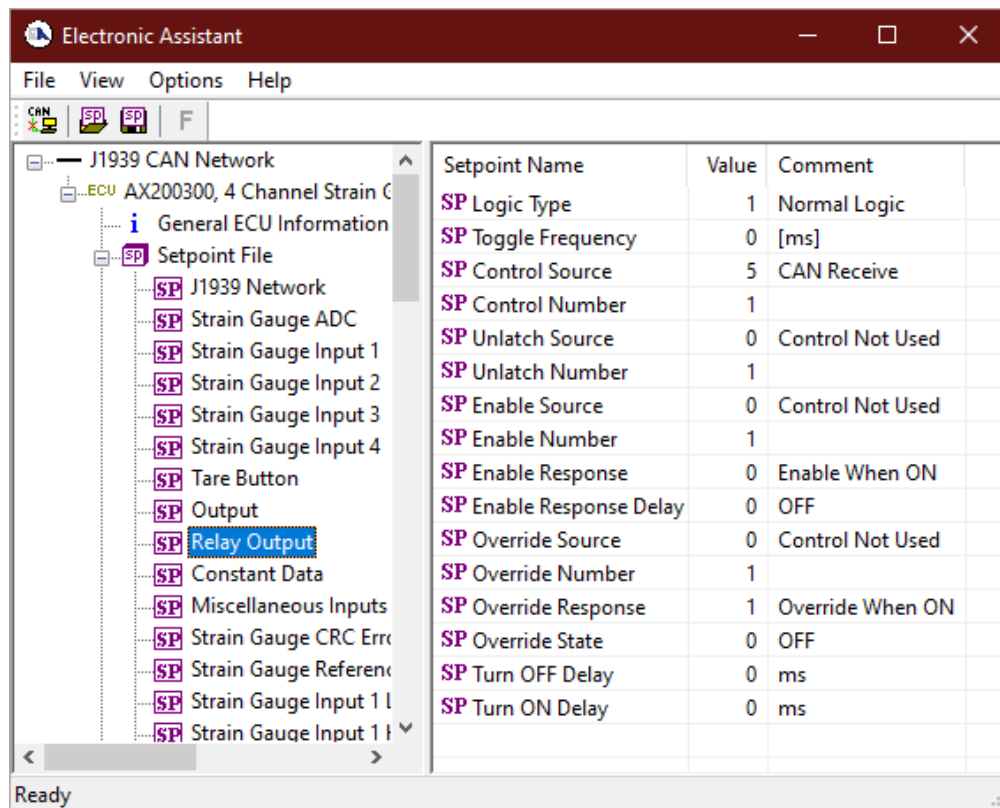

Screen Capture of Default Interlock/Relay Output Setpoints

Name	Range	Default	Notes
Output Type	Drop List	1 - Digital Output	If value is set to 0, Output is disabled
Logic Type	Drop List	1 - Normal Logic	Refer to Table 12
Toggle Frequency	Depends on Source	1	Refer to Section 1.6.3
Control Source	Drop List	5 - CAN Receive	Refer to Table 6
Control Number	Depends on Source	1	Refer to Table 6
Unlatch Source	Drop List	0 - Control Source Not Used	Refer to Table 6
Unlatch Number	Depends on Source	1	Refer to Table 6
Enable Source	Drop List	0 - Control Source Not Used	Refer to Table 6
Enable Number	Depends on Source	1	Refer to Table 6
Enable Response	Drop List	0 - Enable When On	Refer to Table 11
Enable Response Delay	Drop List	0 - OFF	Refer to Section 1.6.2
Override Source	Drop List	0 - Control Source Not Used	Refer to Table 6

Override Number	Depends on Source	1	Refer to Table 6
Override Response	Drop List	0 - Override When On	Refer to Table 9
Override State	Drop List	0 - OFF	Refer to Table 10
Turn OFF Delay	0 to 86400000	0 ms	Refer to Section 1.6.2
Turn ON Delay	0 to 86400000	0 ms	Refer to Section 1.6.2

#### 4.7. Constant Data List Setpoints

The Constant Data List function block is provided to allow the user to select values as desired for various logic block functions. Throughout this manual, various references have been made to constants, as summarized in the examples listed below.

- a) Programmable Logic: Constant “**Table X = Condition Y, Argument 2**”, where X and Y = 1 to 3
- b) Math Function: Constant “**Math Input X**”, where X = 1 to 4

The 15 constants are fully user configurable to any value between +/- 1,000,000. The default values (shown below) are arbitrary and should be configured by the user as appropriate for their application. Constant Value 1 will be updated if Tare Option 6 ‘Set Overall Minimum Weight’ is selected during zeroing/calibration. Similarly, Constant Value 2 will be updated if Tare Option 7 ‘Set Overall Maximum Weight’ is selected during zeroing/calibration.

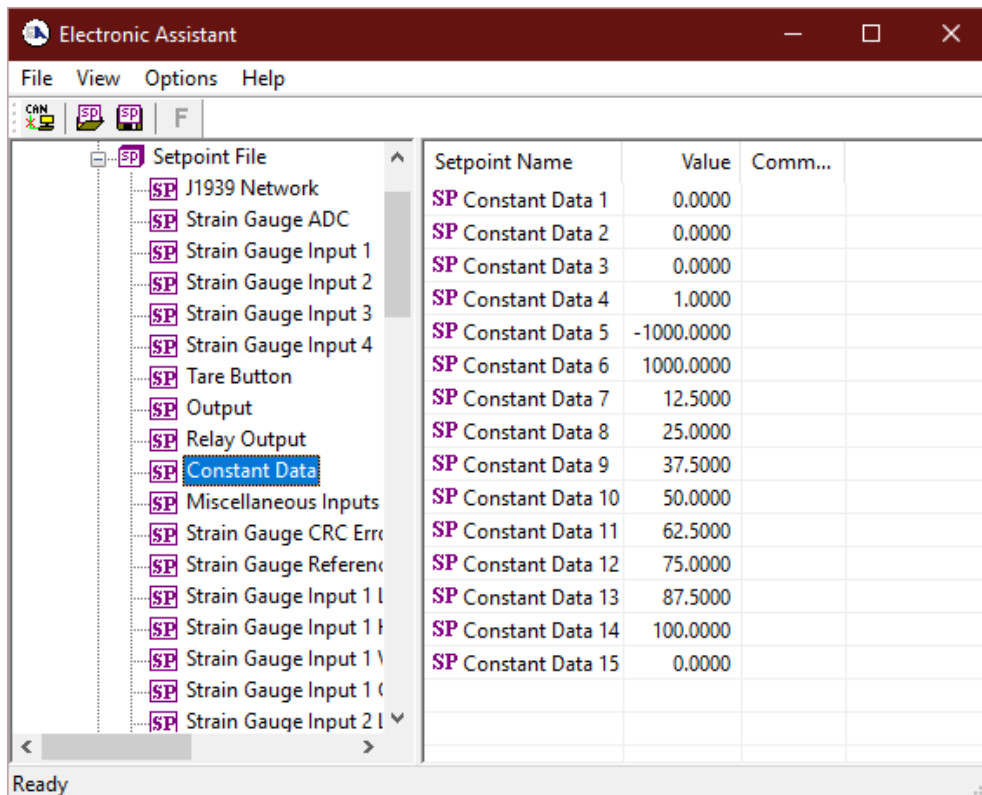

Screen Capture of Default Constant Data List Setpoints

#### 4.8. Miscellaneous Input Setpoints

The Miscellaneous Input function block is defined in Section 1.2. Please refer there for detailed information about how all these setpoints are used.

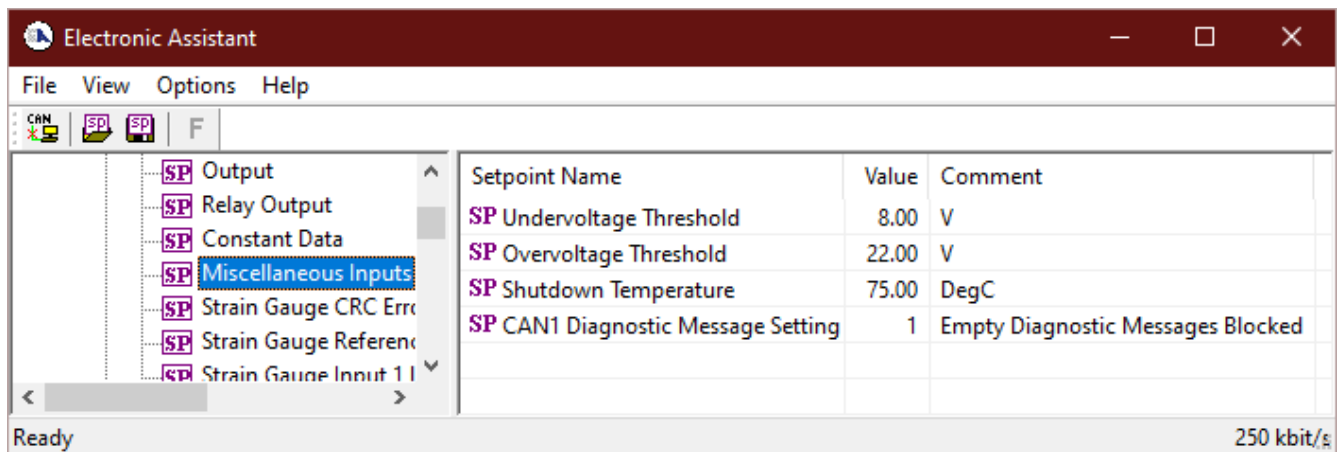

Screen Capture of Default Miscellaneous Input Setpoints

Name	Range	Default	Notes
Undervoltage Threshold	6 to 36	8 V	Refer to Section 1.7
Overvoltage Threshold	6 to 36	24 V	Refer to Section 1.7
Shutdown Temperature	40 to 125	75 °C	Refer to Section 1.7
CAN1 Diagnostic Message Setting	Drop List	1 - Empty Diagnostic Messages Blocked	Refer to Section 1.7

#### 4.9. Diagnostic Setpoints

The Diagnostic setpoints are defined in Section 1.8. Refer to that subsection for detailed information on how these setpoints are used.

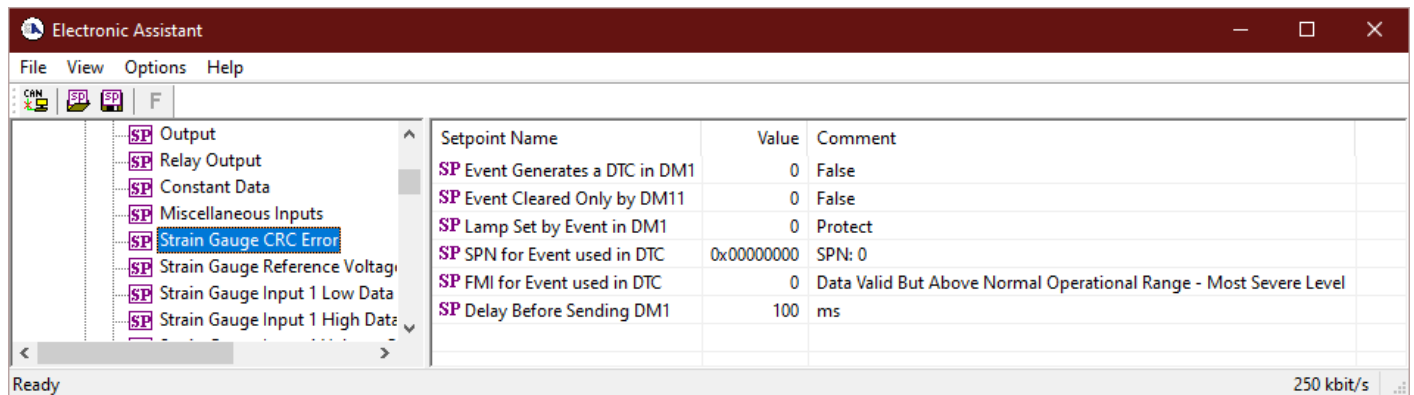

Screen Capture of Default Diagnostic Setpoints

Name	Range	Default	Notes
Event Generates a DTC in DM1	Drop List	False	Default changed to <i>True</i> for illustration purposes, Refer to Section 1.8
Event Cleared Only by DM11	Drop List	False	Refer to Section 1.8
Lamp Set by Event in DM1	Drop List	Amber, Warning	Refer to Section 1.8
SPN for Event used in DTC	0 to 524,287	520704	Refer to Section 1.8
FMI for Event used in DTC	Drop List	Voltage Below Normal, Or Shorted to Low Source	Refer to Table 13
Delay Before Sending DM1	0 to 84,600,000	1000 ms	Units in [milliseconds]
Delay Before Clearing DM1	0 to 84,600,000	0	If digital output OFF after this time, a DTC will not be sent on a DM1 message anymore.

## 4.10. Math Function Setpoints

The Math Function block is defined in Section 1.9. Please refer there for detailed information about how all these setpoints are used.

Setpoint Name	Value	Comment
SP Math Enabled	1	True
SP Math Output Minimum Range	0.00	
SP Math Output Maximum Range	100.00	
SP Function 1 Input A Source	3	Strain Gauge Weight Data
SP Function 1 Input A Number	1	
SP Function 1 Input A Minimum	0.00	
SP Function 1 Input A Maximum	100.00	
SP Function 1 Input A Gain	1.00	
SP Function 1 Input B Source	3	Strain Gauge Weight Data
SP Function 1 Input B Number	2	
SP Function 1 Input B Minimum	0.00	
SP Function 1 Input B Maximum	100.00	
SP Function 1 Input B Gain	1.00	
SP Math Function 1 Operation	9	+, Result = InA plus InB
SP Function 2 Input B Source	3	Strain Gauge Weight Data
SP Function 2 Input B Number	3	
SP Function 2 Input B Minimum	0.00	
SP Function 2 Input B Maximum	100.00	
SP Function 2 Input B Gain	1.00	
SP Math Function 2 Operation (Input A = Result of Function 1)	9	+, Result = InA plus InB
SP Function 3 Input B Source	3	Strain Gauge Weight Data
SP Function 3 Input B Number	4	
SP Function 3 Input B Minimum	0.00	
SP Function 3 Input B Maximum	100.00	
SP Function 3 Input B Gain	1.00	
SP Math Function 3 Operation (Input A = Result of Function 2)	9	+, Result = InA plus InB

Screen Capture of Example Math Function 1 Setpoints

Note: In the screen capture shown above, the “Math Function Enabled” has been changed from its default value in order to enable the function block. Other setpoints have also been changed from default values to illustrate how the block might look when functional, as per the example outlined in Section 1.9.

Name	Range	Default	Notes
Math Function Enabled	Drop List	False	
Math Output Minimum Range	$-10^6$ to $10^6$	0.0	
Math Output Maximum Range	$-10^6$ to $10^6$	100.0	
Function 1 Input A Source	Drop List	Control not used	Refer to Table 6
Function 1 Input A Number	Depends on control source	1	Refer to Table 6
Function 1 Input A Minimum	$-10^6$ to $10^6$	0.0	
Function 1 Input A Maximum	$-10^6$ to $10^6$	100.0	

Function 1 Input A Scaler	-1.00 to 1.00	1.00	
Function 1 Input B Source	Drop List	Control not used	Refer to Table 6
Function 1 Input B Number	Depends on control source	1	Refer to Table 6
Function 1 Input B Minimum	$-10^6$ to $10^6$	0.0	
Function 1 Input B Maximum	$-10^6$ to $10^6$	100.0	
Function 1 Input B Scaler	-1.00 to 1.00	1.00	
Math Function 1 Operation	Drop List	=, True when InA Equals InB	Refer to Table 14
Function 2 Input B Source	Drop List	Control not used	Refer to Table 6
Function 2 Input B Number	Depends on control source	1	Refer to Table 6
Function 2 Input B Minimum	$-10^6$ to $10^6$	0.0	
Function 2 Input B Maximum	$-10^6$ to $10^6$	100.0	
Function 2 Input B Scaler	-1.00 to 1.00	1.00	
Math Function 3 Operation	Drop List	=, True when InA Equals InB	Refer to Table 14
Function 3 Input B Source	Drop List	Control not used	Refer to Table 6
Function 3 Input B Number	Depends on control source	1	Refer to Table 6
Function 3 Input B Minimum	$-10^6$ to $10^6$	0.0	
Function 3 Input B Maximum	$-10^6$ to $10^6$	100.0	
Function 3 Input B Scaler	-1.00 to 1.00	1.00	
Math Function 3 Operation	Drop List	=, True when InA Equals InB	Refer to Table 14

## 4.11. Programmable Logic Setpoints

The Programmable Logic function block is defined in Section 1.10. Please refer there for detailed information about how all these setpoints are used.

As this function block is disabled by default, there is nothing further to define in terms of defaults and ranges beyond that which is described in Section 1.10. The screen capture below shows how the setpoints referenced in that section appear on EA.

Setpoint Name	Value	Comment
SP Logic Enabled	1	True
SP Table Number 1	1	Lookup Table 1
SP Logical Operator 1	1	Cnd1 And Cnd2 And Cnd3
SP Table 1 - Condition 1 Argument 1 Source	0	Control Not Used
SP Table 1 - Condition 1 Argument 1 Number	1	
SP Table 1 - Condition 1 Argument 2 Source	0	Control Not Used
SP Table 1 - Condition 1 Argument 2 Number	1	
SP Table 1 - Condition 1 Operator	0	=, Equal
SP Table 1 - Condition 2 Argument 1 Source	0	Control Not Used
SP Table 1 - Condition 2 Argument 1 Number	1	
SP Table 1 - Condition 2 Argument 2 Source	0	Control Not Used
SP Table 1 - Condition 2 Argument 2 Number	1	
SP Table 1 - Condition 2 Operator	0	=, Equal
SP Table 1 - Condition 3 Argument 1 Source	0	Control Not Used
SP Table 1 - Condition 3 Argument 1 Number	1	
SP Table 1 - Condition 3 Argument 2 Source	0	Control Not Used
SP Table 1 - Condition 3 Argument 2 Number	1	
SP Table 1 - Condition 3 Operator	0	=, Equal
SP Table Number 2	2	Lookup Table 2
SP Logical Operator 2	1	Cnd1 And Cnd2 And Cnd3
SP Table 2 - Condition 1 Argument 1 Source	0	Control Not Used
SP Table 2 - Condition 1 Argument 1 Number	1	
SP Table 2 - Condition 1 Argument 2 Source	0	Control Not Used
SP Table 2 - Condition 1 Argument 2 Number	1	
SP Table 2 - Condition 1 Operator	0	=, Equal
SP Table 2 - Condition 2 Argument 1 Source	0	Control Not Used
SP Table 2 - Condition 2 Argument 1 Number	1	
SP Table 2 - Condition 2 Argument 2 Source	0	Control Not Used
SP Table 2 - Condition 2 Argument 2 Number	1	
SP Table 2 - Condition 2 Operator	0	=, Equal
SP Table 2 - Condition 3 Argument 1 Source	0	Control Not Used
SP Table 2 - Condition 3 Argument 1 Number	1	
SP Table 2 - Condition 3 Argument 2 Source	0	Control Not Used
SP Table 2 - Condition 3 Argument 2 Number	1	
SP Table 2 - Condition 3 Operator	0	=, Equal
SP Table Number 3	3	Lookup Table 3
SP Logical Operator 3	1	Cnd1 And Cnd2 And Cnd3
SP Table 3 - Condition 1 Argument 1 Source	0	Control Not Used
SP Table 3 - Condition 1 Argument 1 Number	1	
SP Table 3 - Condition 1 Argument 2 Source	0	Control Not Used
SP Table 3 - Condition 1 Argument 2 Number	1	
SP Table 3 - Condition 1 Operator	0	=, Equal
SP Table 3 - Condition 2 Argument 1 Source	0	Control Not Used
SP Table 3 - Condition 2 Argument 1 Number	1	
SP Table 3 - Condition 2 Argument 2 Source	0	Control Not Used
SP Table 3 - Condition 2 Argument 2 Number	1	
SP Table 3 - Condition 2 Operator	0	=, Equal
SP Table 3 - Condition 3 Argument 1 Source	0	Control Not Used
SP Table 3 - Condition 3 Argument 1 Number	1	
SP Table 3 - Condition 3 Argument 2 Source	0	Control Not Used
SP Table 3 - Condition 3 Argument 2 Number	1	
SP Table 3 - Condition 3 Operator	0	=, Equal

Screen Capture of Default Programmable Logic 1 Setpoints

Note: In the screen capture shown above, the “Programmable Logic Block Enabled” has been changed from its default value in order to enable the function block.

Note: The default values for the Argument 1, Argument 2 and Operator are all the same across all the Programmable Logic function blocks and must therefore be changed by the user as appropriate before this can be used.

### 4.12. Lookup Table Setpoints

The Lookup Table function block is defined in Section 1.11. Please refer there for detailed information about how all these setpoints are used. As this function block’s X-Axis defaults are defined by the “X-Axis Source” selected from Table 6, there is nothing further to define in terms of defaults and ranges beyond that which is described in Section 1.11. Recall, the X-Axis values will be automatically updated if the min/max range of the selected source is changed.

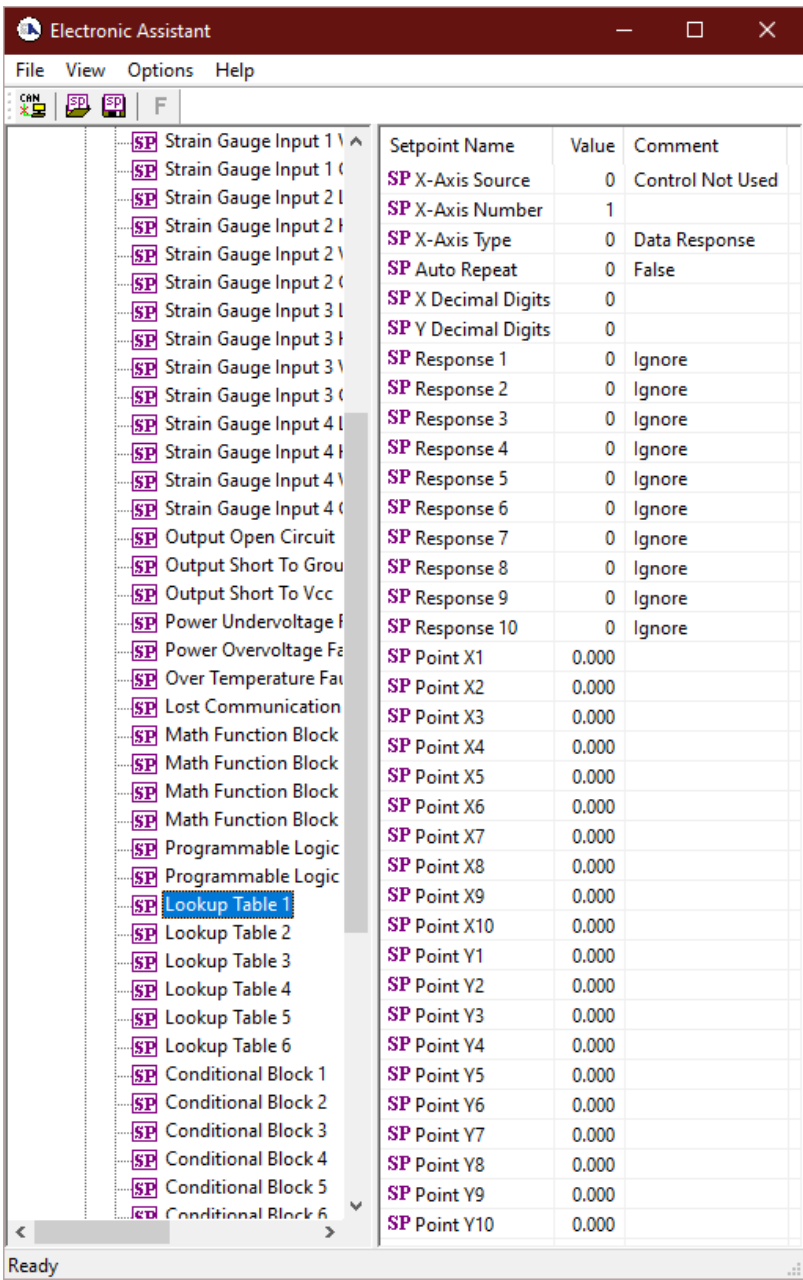

Screen Capture of Example Lookup Table 1 Setpoints

Note: In the screen capture shown above, the “X-Axis Source” has been changed from its default value in order to enable the function block.

### 4.13. Conditional Function Block Setpoints

The Conditional Logic function blocks are defined in Section 1.12. Please refer to that section for more details on the functionality of these blocks. The user can make up to two comparisons per block. The output of this function block is only 1 (TRUE) or 0 (FALSE).

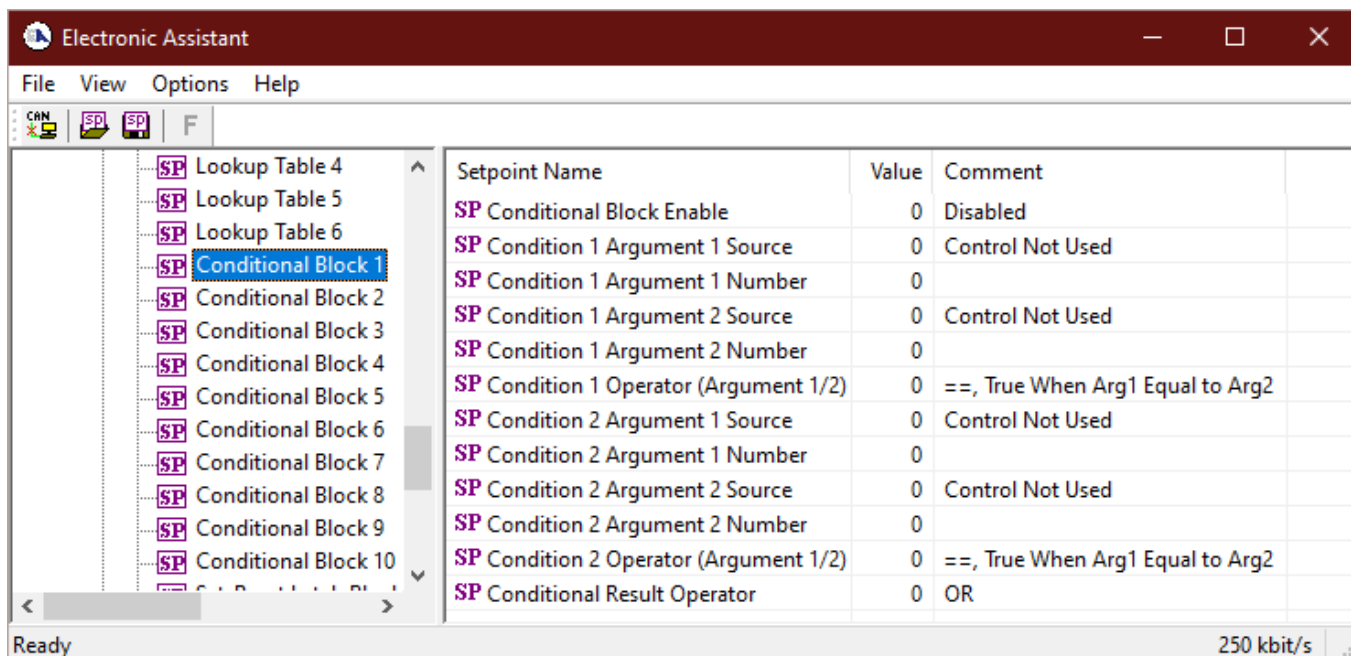

Screen Capture of Default Conditional Block Setpoints

### 4.14. Set-Reset Latch Block

The Set-Reset Latch Block setpoints are defined in Section 1.13. Refer to that section for detailed information on how these setpoints are used.

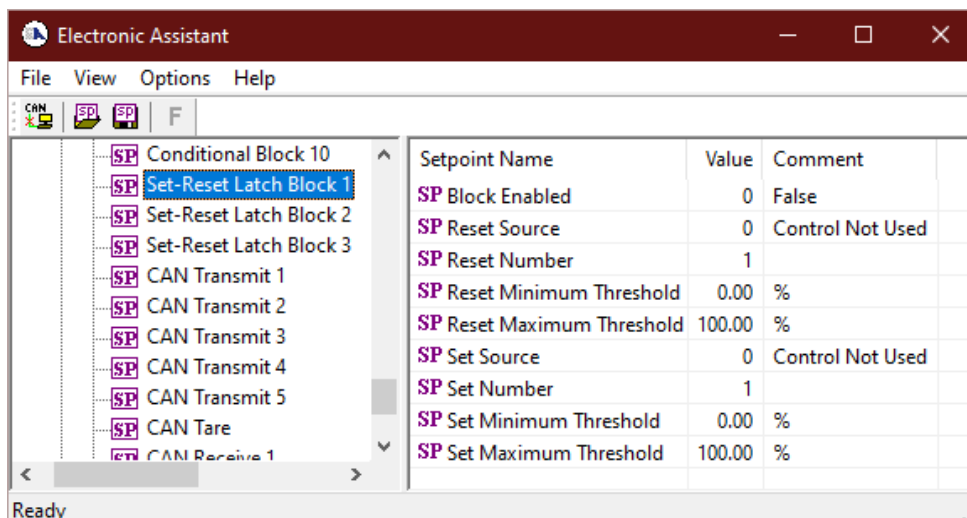

Screen Capture of Set-Reset Latch Block Setpoints

<b>Name</b>	<b>Range</b>	<b>Default</b>	<b>Notes</b>
Block Enabled	Drop List	False	
Reset Source	Drop List	Control Not Used	Refer to Table 6
Reset Number		1	Refer to Table 6
Reset Minimum Threshold	Drop List	0%	Refer to Section 1.13
Reset Maximum Threshold		100%	Refer to Section 1.13
Set Source	Drop List	Control Not Used	Refer to Table 6
Set Number	Drop List	1	Refer to Table 6
Set Minimum Threshold		0%	Refer to Section 1.13
Set Maximum Threshold	Drop List	100%	Refer to Section 1.13

#### **4.15. CAN Transmit Setpoints**

The CAN Transmit function block is defined in Section 1.14, with addition information in Section 3.3. Please refer there for detailed information about how all these setpoints are used.

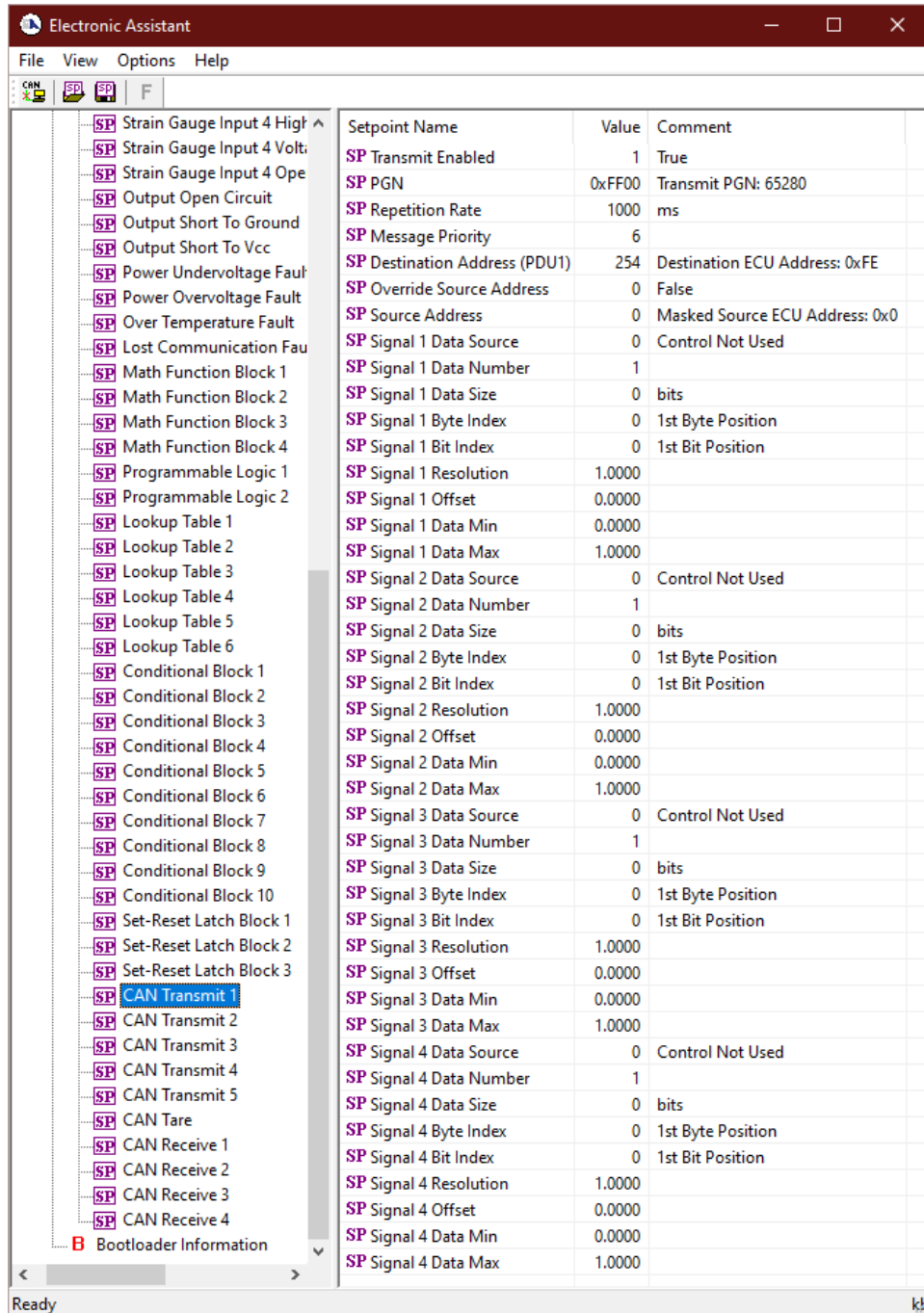

Screen Capture of Default CAN Transmit 1 Setpoints

Name	Range	Default	Notes
Transmit Enabled	Drop List	1 - True	
PGN	0 to 65535	65280 (\$FF00)	See Section 3.3 for defaults
Repetition Rate	0 to 60,000 ms	0	0ms disables transmit
Message Priority	0 to 7	6	Proprietary B Priority
Destination Address (for PDU1)	0 to 255	254 (0xFE, Null Address)	Not used by default
Override Source Address	Drop List	No	
Source Address	0 to 255	130 (0x82)	Source Address to Mask
Signal x Data Source	Drop List	Different for each	Refer to Table 6
Signal x Data Number	Per Source	Different for each	Refer to Table 6
Signal x Data Size	0 to 32	16 bits	
Signal x Byte Index	0 to 7	Different for each	
Signal x Bit Index	0 to Data Size	Different for each	

Signal x Data Resolution	-0xFFFFFFFF to 0xFFFFFFFF	Different for each	See Section 3.3 for defaults
Signal x Data Offset	-0xFFFFFFFF to 0xFFFFFFFF	Different for each	See Section 3.3 for defaults
Signal x Data Min	-0xFFFFFFFF to Data Max		
Signal x Data Max	Data Min to 0xFFFFFFFF		

### 4.16. CAN Tare Setpoints

The CAN Tare function block is defined in Section 1.15. It is used to calibrate/tare the strain gauge input of the 4CH-SG controller. Please refer to that section for detailed information about how all these setpoints are used.

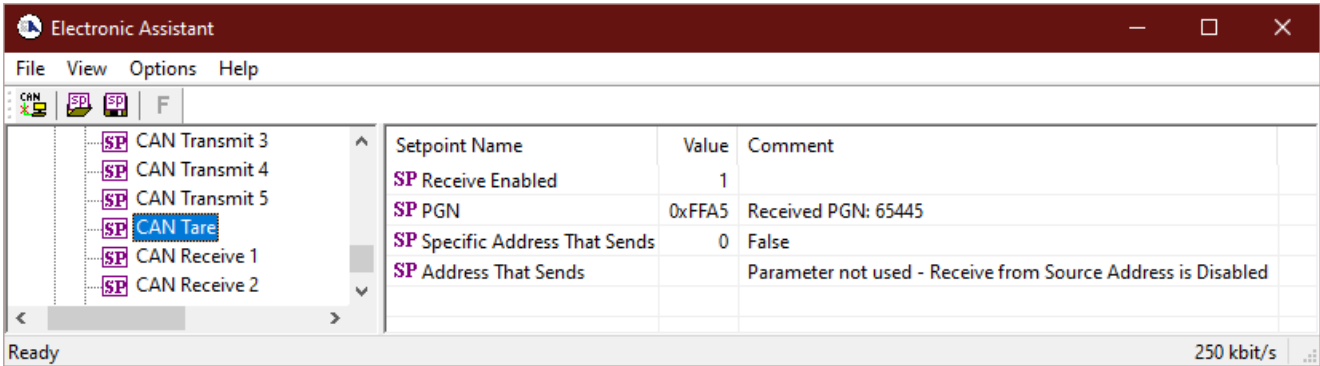

Screen Capture of Default CAN Tare Setpoints

Name	Range	Default	Notes
Received Message Enabled	Drop List	True	Enables or disables CAN Tare Function
Receive PGN	0 to 65535	0xFFA5	Any PGN
Specific Address That Sends	Drop List	False	If set to True, 4CH-SG communicates with ECU address selected
Address That Sends	0 to 254	0x00	ECU Address of sender

### 4.17. CAN Receive Setpoints

The CAN Receive function block is defined in Section 1.16. Please refer there for detailed information about how all these setpoints are used.

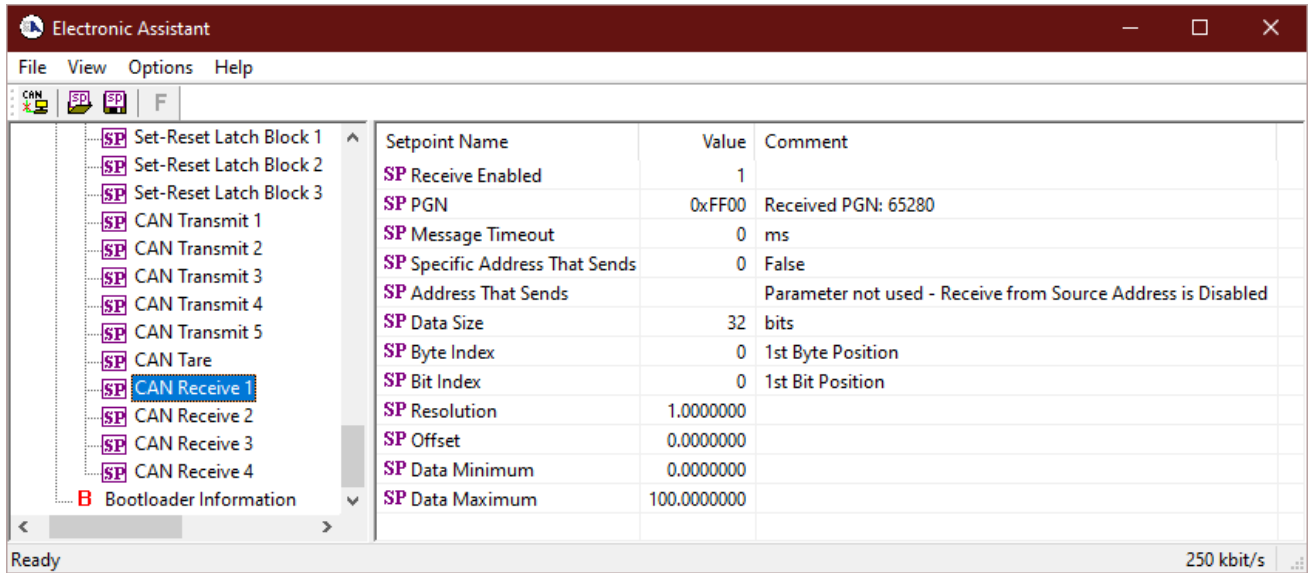

Screen Capture of Default CAN Receive 1 Setpoints

*Note: In the screen capture shown above, the “Receive Message Enabled” has been changed from its default value in order to enable the function block*

## 5. REFLASHING OVER CAN WITH EA BOOTLOADER

The AX200300 can be upgraded with new application firmware using the **Bootloader Information** section. This section details the simple step-by-step instructions to upload new firmware provided by Axiomatic onto the unit via CAN, without requiring it to be disconnected from the J1939 network.

1. When EA first connects to the ECU, the **Bootloader Information** section will display the following information.

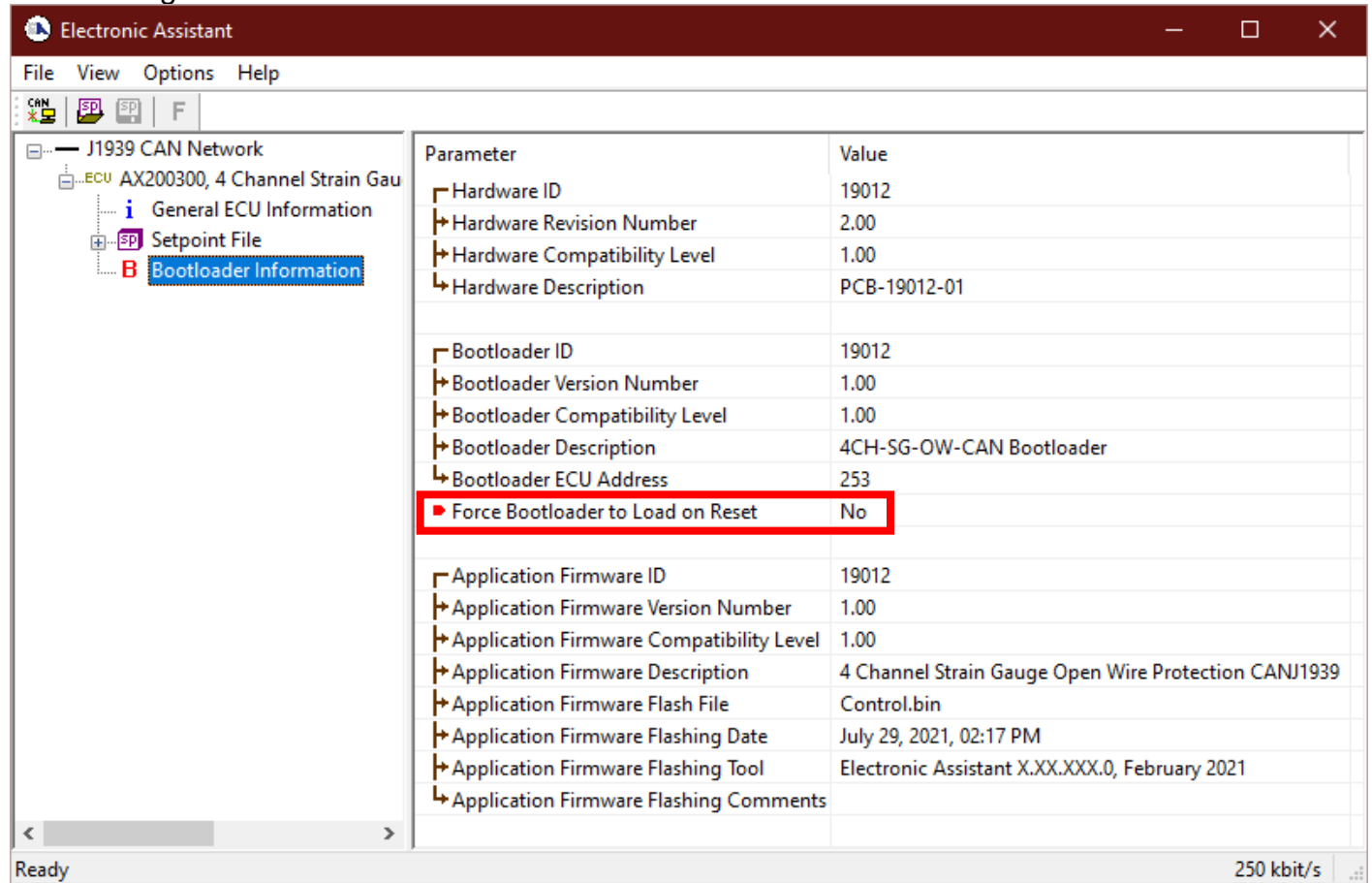

2. To use the bootloader to upgrade the firmware running on the ECU, change the variable **“Force Bootloader To Load on Reset”** to Yes.

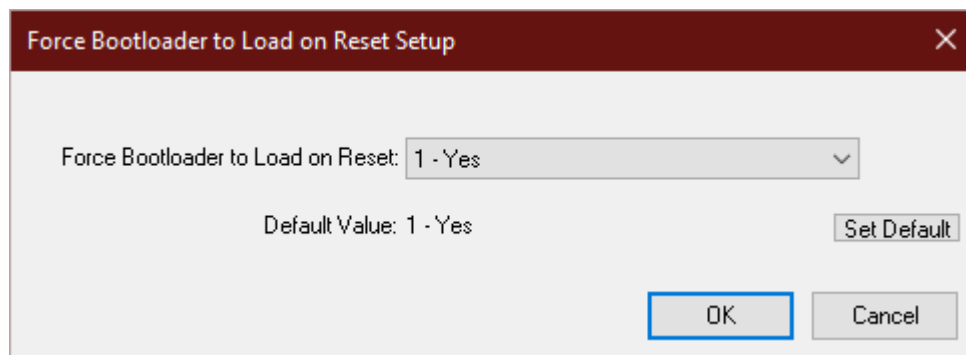

3. When the prompt box asks if you want to reset the ECU, select Yes.

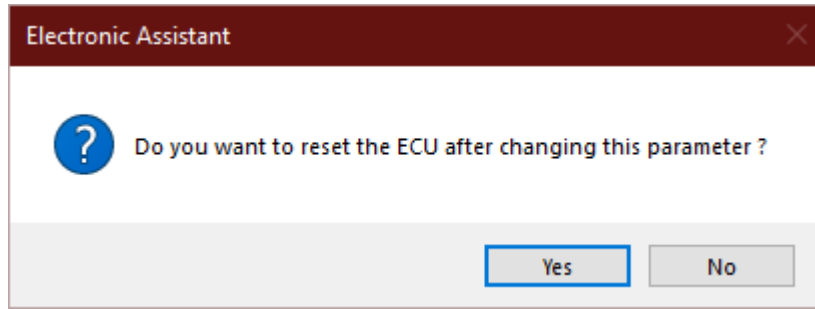

4. Upon reset, the ECU will no longer work on the J1939 network as an AX200300 but rather as **J1939 Bootloader #1**.

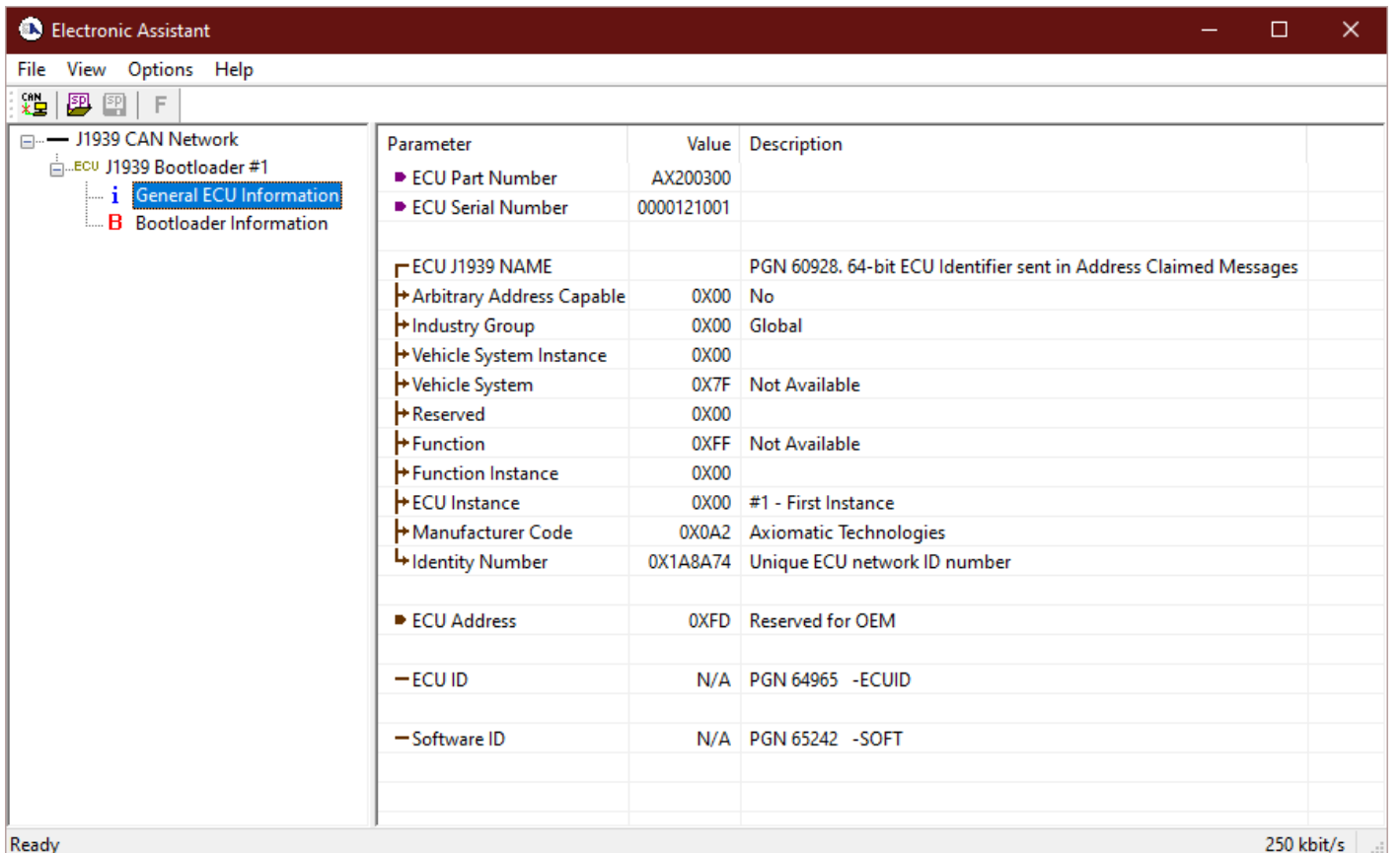
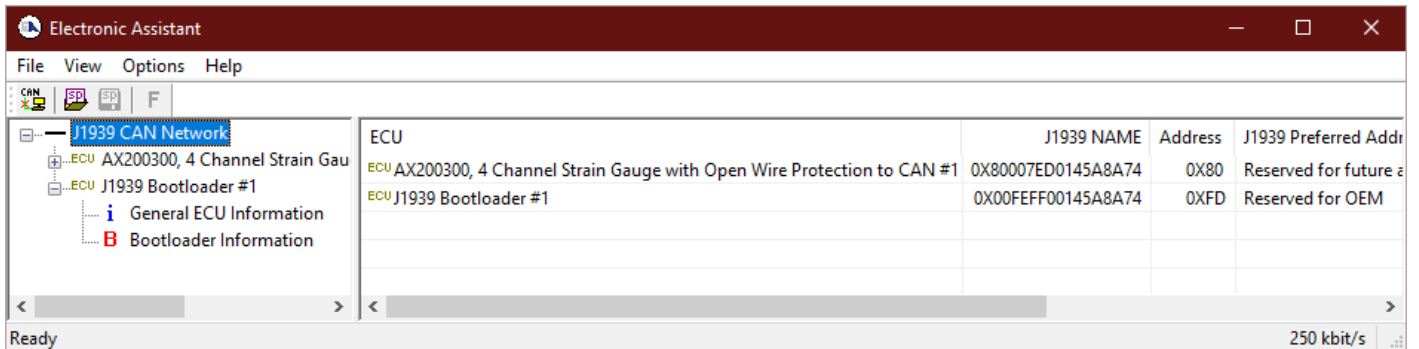

*Note that the bootloader is NOT Arbitrary Address Capable. This means that if you want to have multiple bootloaders running simultaneously (not recommended) you would have to manually change the address for each one before activating the next, or there will be address conflicts, and*

only one ECU would show up as the bootloader. Once the 'active' bootloader returns to regular functionality, the other ECU(s) would have to be power cycled to re-activate the bootloader feature.

- When the **Bootloader Information** section is selected, the same information is shown as when it was running the AX200300 firmware, but in this case the **F**lashing feature has been enabled.

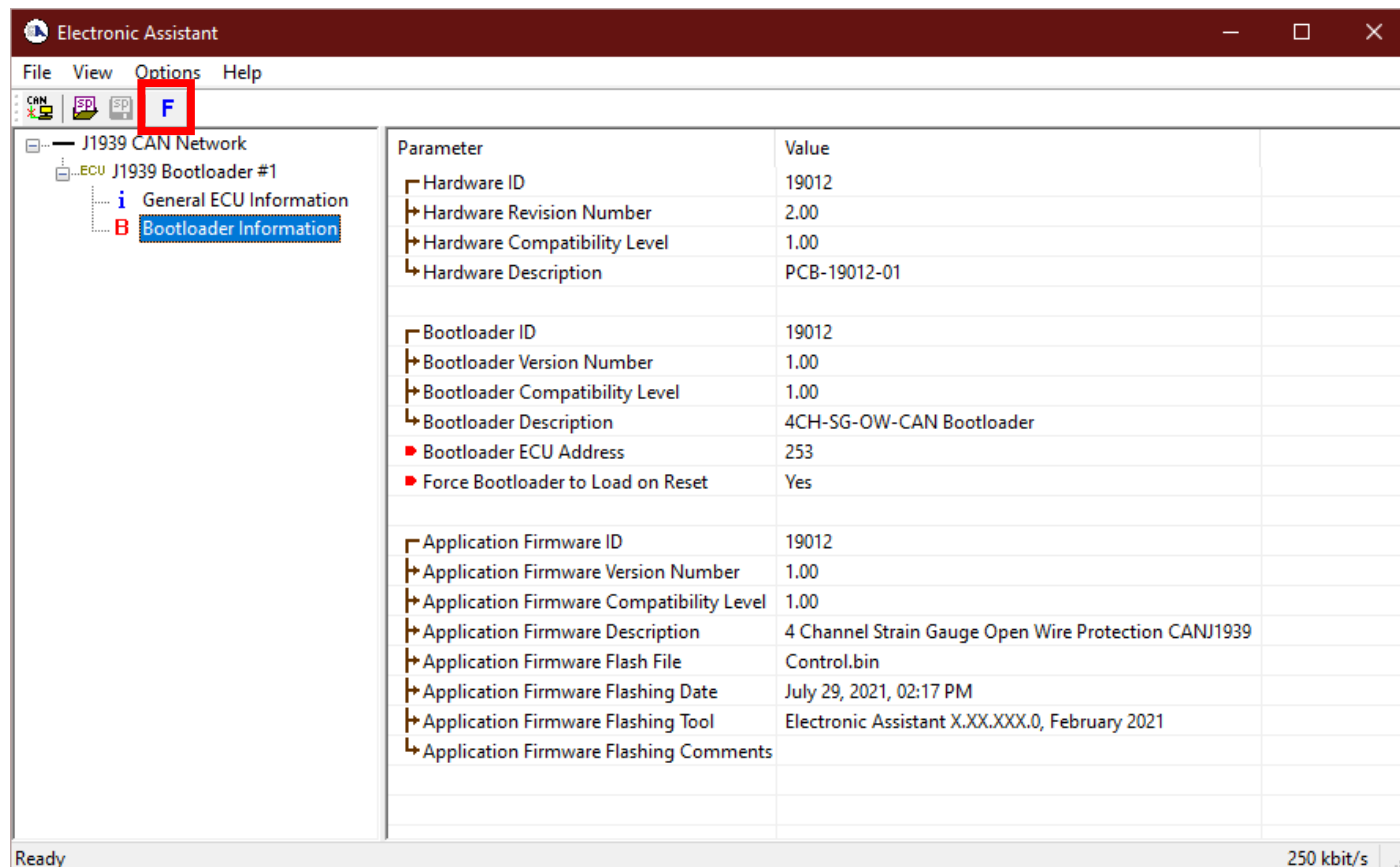

- Select the **F**lashing button and navigate to where you had saved the **AF-19012-x.yy.bin** file sent from Axiomatic. (Note: only binary (.bin) files can be flashed using the EA tool)
- Once the Flash Application Firmware window opens, you can enter comments such as "Firmware upgraded by [Name]" if you so desire. This is not required, and you can leave the field blank if you do not want to use it.

Note: You do not have to date/time-stamp the file, as this is done automatically by the EA tool when you upload the new firmware.

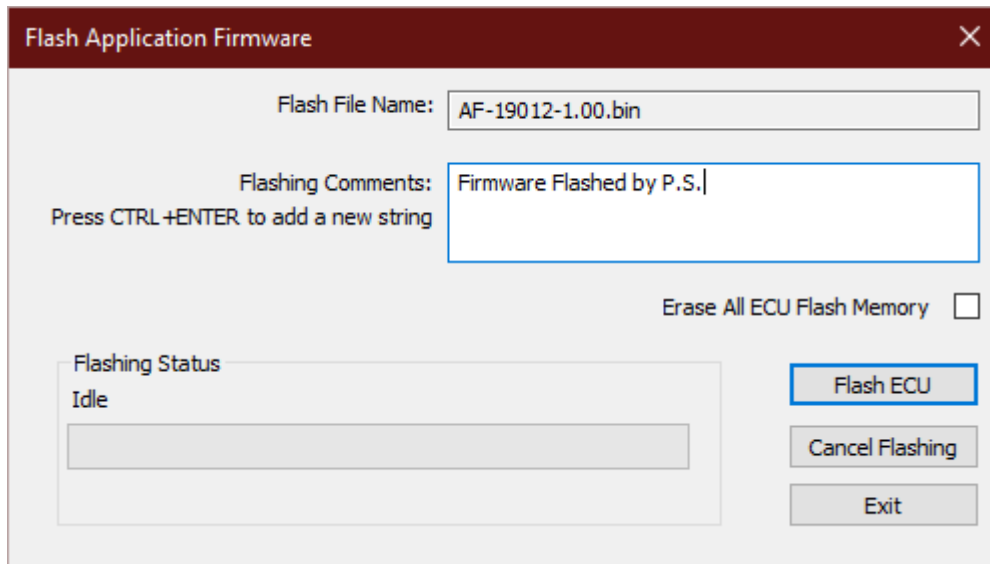

 **WARNING:** Do not check the “Erase All ECU Flash Memory” box unless instructed to do so by your Axiomatic contact. Selecting this will erase ALL data stored in non-volatile flash. It will also erase any configuration of the setpoints that might have been done to the ECU and reset all setpoints to their factory defaults. By leaving this box unchecked, none of the setpoints will be changed when the new firmware is uploaded.

8. A progress bar will show how much of the firmware has been sent as the upload progresses. The more traffic there is on the J1939 network, the longer the upload process will take.

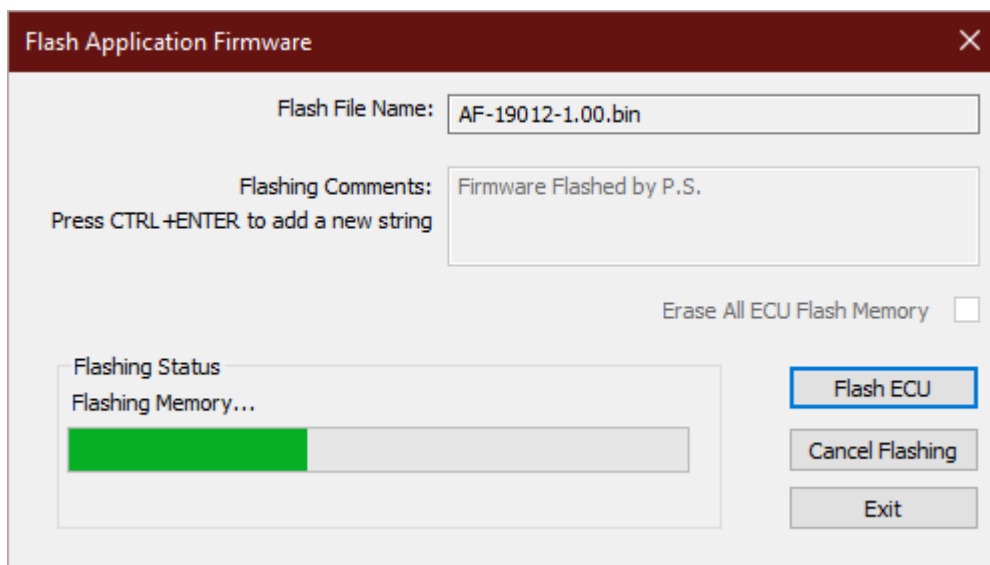

9. Once the firmware has finished uploading, a message will popup indicating the successful operation. If you select to reset the ECU, the new version of the AX200300 application will start running, and the ECU will be identified as such by EA. Otherwise, The next time the ECU is power-cycled, the AX200300 application will run rather than the bootloader function.

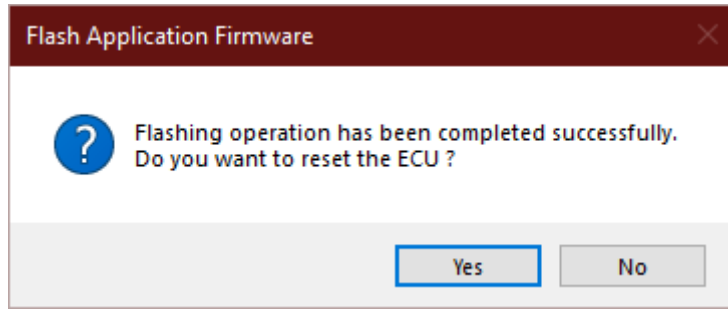

Note: If at any time during the upload the process is interrupted, the data is corrupted (bad checksum) or for any other reason the new firmware is not correct, i.e. bootloader detects that the file loaded was not designed to run on the hardware platform, the bad or corrupted application will not run. Rather, when the ECU is reset or power-cycled the **J1939 Bootloader** will continue to be the default application until valid firmware has been successfully uploaded into the unit.

## 6. Technical Specifications

### 6.1. Power Supply

Power Supply Input - Nominal	12 or 24Vdc nominal operating voltage 8...36 Vdc power supply range for voltage transients
Surge Protection	Provided
Reverse Polarity Protection	Provided

### 6.2. Inputs

Strain Gauge Inputs	4 Channels Accepts 4-wire Strain Gauge inputs Input range selectable from +/- 19.5 mV to +/- 2.5 Vdc. All input channels have excitation and ground connections provided. All inputs send a message to the CAN bus.
Measurement rate	The measurement rate is 2.5 scans per second for all 4 channels. The update rate is 400 mSec. for all 4 channels.
Common-mode	Common-mode rejection is > 100 db@ 1V p-p, simultaneous 50/60 Hz. Common mode input range is +/- 3.5V maximum.
Resolution	18.2-Bit noise-free minimum
Drift	Overall drift with temperature is 50 ppm/°C of span (maximum).
Input Accuracy	+/- 0.5% throughout the entire range of the input
Excitation	4 +5V excitation connections
Other Input	1 Digital Input Active High to 5V or Active Low to GND Configurable Pull Up or Pull Down Resistor Amplitude: up to +Vps
Grounds	4 GND connections

### 6.3. Output

Analog/Digital Output	1 Analog/Digital Output Analog Output has selectable range of 0 to 10V and 0 to 24mA Digital Output On/Off Fully protected high side digital switch with low current readings 2A Overcurrent, overvoltage and undervoltage protection is provided.
Relay Output	An interlock relay with 2 contact pins is provided. 2A (nominal)

### 6.4. Communication

CAN	1 CAN 2.0B port, protocol SAE J1939
Network Termination	According to the CAN standard, it is necessary to terminate the network with external termination resistors. The resistors are 120 Ohm, 0.25W minimum, metal film or similar type. They should be placed between CAN_H and CAN_L terminals at both ends of the network.

### 6.5. General Specifications

Microprocessor	STM32F407VGT7
Communications	1 CAN port (SAE J1939) Baud rate: 250, 500, 667 kbit/s, 1 Mbit/s. Automatic baud rate detection.
User Interface	Electronic Assistant®, P/N: AX070502
Wire Break Detection	Included
Control Logic	Standard embedded control logic is provided. Application-specific control logic is available on request.
SAE J1939 Compliance	The ECU is compliant with the following SAE J1939 standards. <ul style="list-style-type: none"> <li>J1939 Recommended Practice for a Serial Control and Communications Vehicle Network, SAE, April 2011</li> <li>J1939/21 Data Link Layer, SAE, December 2010</li> <li>J1939/71 Vehicle Application Layer, SAE, March 2011</li> <li>J1939/81 Network Management, SAE, May 2003</li> </ul>

Electrical Connections	<p>TE Deutsch DTM series 24 pin receptacle: DTM13-12PA-12PB-R008  Mating plug: TE Deutsch DTM06-12SA and DTM06-12SB  with 2 wedgelocks (WM12S) and 24 contacts (0462-201-20141).  20 AWG wire is recommended for use with contacts 0462-201-20141.</p> <table border="1" data-bbox="670 281 1305 688"> <thead> <tr> <th colspan="2">Grey Connector</th> <th colspan="2">Black Connector</th> </tr> <tr> <th>Pin #</th> <th>Function</th> <th>Pin #</th> <th>Function</th> </tr> </thead> <tbody> <tr> <td>1</td> <td>+5V Excitation 1</td> <td>1</td> <td>GND 3</td> </tr> <tr> <td>2</td> <td>V IN 1+</td> <td>2</td> <td>V IN 3-</td> </tr> <tr> <td>3</td> <td>+5V Excitation 2</td> <td>3</td> <td>GND 4</td> </tr> <tr> <td>4</td> <td>V IN 2+</td> <td>4</td> <td>V IN 4-</td> </tr> <tr> <td>5</td> <td>Tare Input</td> <td>5</td> <td>Interlock +/-</td> </tr> <tr> <td>6</td> <td>BATT-</td> <td>6</td> <td>CAN_H</td> </tr> <tr> <td>7</td> <td>BATT+</td> <td>7</td> <td>CAN_L</td> </tr> <tr> <td>8</td> <td>Digital Output</td> <td>8</td> <td>Interlock +/-</td> </tr> <tr> <td>9</td> <td>V IN 2 -</td> <td>9</td> <td>V IN 4+</td> </tr> <tr> <td>10</td> <td>GND 2</td> <td>10</td> <td>+5V Excitation 4</td> </tr> <tr> <td>11</td> <td>V IN 1 -</td> <td>11</td> <td>V IN 3+</td> </tr> <tr> <td>12</td> <td>GND 1</td> <td>12</td> <td>+5V Excitation 3</td> </tr> </tbody> </table>	Grey Connector		Black Connector		Pin #	Function	Pin #	Function	1	+5V Excitation 1	1	GND 3	2	V IN 1+	2	V IN 3-	3	+5V Excitation 2	3	GND 4	4	V IN 2+	4	V IN 4-	5	Tare Input	5	Interlock +/-	6	BATT-	6	CAN_H	7	BATT+	7	CAN_L	8	Digital Output	8	Interlock +/-	9	V IN 2 -	9	V IN 4+	10	GND 2	10	+5V Excitation 4	11	V IN 1 -	11	V IN 3+	12	GND 1	12	+5V Excitation 3
Grey Connector		Black Connector																																																							
Pin #	Function	Pin #	Function																																																						
1	+5V Excitation 1	1	GND 3																																																						
2	V IN 1+	2	V IN 3-																																																						
3	+5V Excitation 2	3	GND 4																																																						
4	V IN 2+	4	V IN 4-																																																						
5	Tare Input	5	Interlock +/-																																																						
6	BATT-	6	CAN_H																																																						
7	BATT+	7	CAN_L																																																						
8	Digital Output	8	Interlock +/-																																																						
9	V IN 2 -	9	V IN 4+																																																						
10	GND 2	10	+5V Excitation 4																																																						
11	V IN 1 -	11	V IN 3+																																																						
12	GND 1	12	+5V Excitation 3																																																						
Packaging and Dimensions	High Temperature Nylon housing – TE Deutsch PCB Enclosure (EEC-325X4B) 4.68 x 5.25 x 1.42 inches 119 x 133 x 36 mm (W x L x H excluding mating plugs)																																																								
Operating Conditions	-40 to 85°C (-40 to 185°F)																																																								
Weight	0.50 lb. (0.23 kg)																																																								
Protection	IP67, PCB assembly is conformal coated.																																																								
Vibration	MIL-STD-202G, Test 204D and 214A (Sine and Random) 10 g peak (Sine) 7.86 Grms peak (Random)																																																								
Shock	MIL-STD-202G, Test 213B 50g																																																								
Mounting	Mounting holes sized for ¼ inch or M6 bolts. The bolt length will be determined by the end-user's mounting plate thickness. The mounting flange of the controller is 0.63 inches (16 mm) thick. All field wiring should be suitable for the operating temperature range. Install the unit with appropriate space available for servicing and for adequate wire harness access (6 inches or 15 cm) and strain relief (12 inches or 30 cm).																																																								

## 7. VERSION HISTORY

---

<b>Version</b>	<b>Date</b>	<b>Author</b>	<b>Modifications</b>
1	August 13 <sup>th</sup> , 2021	Peter Sotirakos	Initial Draft; Modified from UMAX200000 V3A

## OUR PRODUCTS

AC/DC Power Supplies  
Actuator Controls/Interfaces  
Automotive Ethernet Converters  
Battery Chargers  
CAN Controls, Routers, Repeaters  
CAN/WiFi, CAN/Bluetooth  
Current/Voltage Converters  
DC/DC Power Converters  
Engine Temperature Scanners  
Ethernet/CAN Converters,  
Gateways, Switches  
Fan Drive Controllers  
Gateways, CAN/Modbus Protocols  
Gyroscope Inclinometers  
Hydraulic Valve Controllers  
Inclinometers, Triaxial  
I/O Controls  
LVDT Signal Converters  
Machine Controls  
Modbus Controls  
Motor Controls  
Power Supplies, DC/DC, AC/DC  
PWM Signal Converters/Isolators  
Resolver Signal Conditioners  
Service Tools  
Signal Conditioners, Converters  
Strain Gauge CAN Controls  
Surge Suppressors

## OUR COMPANY

Axiomatic provides electronic machine control components to the off-highway, commercial vehicle, electric vehicle, power generator set, material handling, renewable energy and industrial OEM markets. ***We innovate with engineered and off-the-shelf machine controls that add value for our customers.***

## QUALITY DESIGN AND MANUFACTURING

Axiomatic in Canada has an ISO 9001:2015 design and manufacturing facility.

## SERVICE

All products to be returned to Axiomatic require a Return Materials Authorization Number (RMA#) from [sales@axiomatic.com](mailto:sales@axiomatic.com). Please provide the following information when requesting an RMA number:

- Serial number, part number
- Hours of operation, description of problem
- Wiring set up diagram, application and other comments as needed

## SAFE USE

All products should be serviced by Axiomatic. Do not open the product and perform the service yourself.



This product can expose you to chemicals which are known in the State of California, USA to cause cancer and reproductive harm. For more information go to [www.P65Warnings.ca.gov](http://www.P65Warnings.ca.gov).

## DISPOSAL

Axiomatic products are electronic waste. Please follow your local environmental waste and recycling laws, regulations and policies for safe disposal or recycling of electronic waste.

## WARRANTY, APPLICATION APPROVALS/LIMITATIONS

Axiomatic Technologies Corporation reserves the right to make corrections, modifications, enhancements, improvements, and other changes to its products and services at any time and to discontinue any product or service without notice. Customers should obtain the latest relevant information before placing orders and should verify that such information is current and complete. Users should satisfy themselves that the product is suitable for use in the intended application. All our products carry a limited warranty against defects in material and workmanship. Please refer to our Warranty, Application Approvals/Limitations and Return Materials Process as described on [www.axiomatic.com/service.html](http://www.axiomatic.com/service.html).

## CONTACTS

**Axiomatic Technologies Corporation**  
5915 Wallace Street  
Mississauga, ON  
CANADA L4Z 1Z8  
TEL: +1 905 602 9270  
FAX: +1 905 602 9279  
[www.axiomatic.com](http://www.axiomatic.com)  
[sales@axiomatic.com](mailto:sales@axiomatic.com)

**Axiomatic Technologies Oy**  
Höytämöntie 6  
33880 Lempäälä  
FINLAND  
TEL: +358 103 375 750  
FAX: +358 3 3595 660  
[www.axiomatic.com](http://www.axiomatic.com)  
[salesfinland@axiomatic.com](mailto:salesfinland@axiomatic.com)